

BS EN 61347-1:2015



BSI Standards Publication

Lamp controlgear

Part 1: General and safety requirements

bsi.

...making excellence a habit.™

National foreword

This British Standard is the UK implementation of EN 61347-1:2015. It is identical to IEC 61347-1:2015. It supersedes BS EN 61347-1:2008+A2:2013, which will be withdrawn on 26 March 2018.

The UK participation in its preparation was entrusted by Technical Committee CPL/34, Lamps and Related Equipment, to Subcommittee CPL/34/3, Auxiliaries for lamps.

A list of organizations represented on this committee can be obtained on request to its secretary.

This publication does not purport to include all the necessary provisions of a contract. Users are responsible for its correct application.

© The British Standards Institution 2015.

Published by BSI Standards Limited 2015

ISBN 978 0 580 76479 0

ICS 29.140.99

Compliance with a British Standard cannot confer immunity from legal obligations.

This British Standard was published under the authority of the Standards Policy and Strategy Committee on 30 June 2015.

Amendments/corrigenda issued since publication

| Date | Text affected |
|------|---------------|
|------|---------------|

EUROPEAN STANDARD

EN 61347-1

NORME EUROPÉENNE

EUROPÄISCHE NORM

May 2015

ICS 29.140.99

Supersedes EN 61347-1:2008

English Version

Lamp controlgear - Part 1: General and safety requirements (IEC 61347-1:2015)

Appareillages de lampes - Partie 1: Exigences générales et
exigences de sécurité
(IEC 61347-1:2015)

Geräte für Lampen - Teil 1: Allgemeine und
Sicherheitsanforderungen
(IEC 61347-1:2015)

This European Standard was approved by CENELEC on 2015-03-26. CENELEC members are bound to comply with the CEN/CENELEC Internal Regulations which stipulate the conditions for giving this European Standard the status of a national standard without any alteration.

Up-to-date lists and bibliographical references concerning such national standards may be obtained on application to the CEN-CENELEC Management Centre or to any CENELEC member.

This European Standard exists in three official versions (English, French, German). A version in any other language made by translation under the responsibility of a CENELEC member into its own language and notified to the CEN-CENELEC Management Centre has the same status as the official versions.

CENELEC members are the national electrotechnical committees of Austria, Belgium, Bulgaria, Croatia, Cyprus, the Czech Republic, Denmark, Estonia, Finland, Former Yugoslav Republic of Macedonia, France, Germany, Greece, Hungary, Iceland, Ireland, Italy, Latvia, Lithuania, Luxembourg, Malta, the Netherlands, Norway, Poland, Portugal, Romania, Slovakia, Slovenia, Spain, Sweden, Switzerland, Turkey and the United Kingdom.



European Committee for Electrotechnical Standardization
Comité Européen de Normalisation Electrotechnique
Europäisches Komitee für Elektrotechnische Normung

CEN-CENELEC Management Centre: Avenue Marnix 17, B-1000 Brussels

Foreword

The text of document 34C/1118/FDIS, future edition 3 of IEC 61347-1, prepared by SC 34C, "Auxiliaries for lamps", of IEC TC 34, "Lamps and related equipment", was submitted to the IEC-CENELEC parallel vote and approved by CENELEC as EN 61347-1:2015.

The following dates are fixed:

- latest date by which the document has to be implemented at national level by publication of an identical national standard or by endorsement (dop) 2015-12-26
- latest date by which the national standards conflicting with the document have to be withdrawn (dow) 2018-03-26

This document supersedes EN 61347-1:2008

Attention is drawn to the possibility that some of the elements of this document may be the subject of patent rights. CENELEC [and/or CEN] shall not be held responsible for identifying any or all such patent rights.

This document has been prepared under a mandate given to CENELEC by the European Commission and the European Free Trade Association, and supports essential requirements of EU Directive(s).

This standard covers the Principle Elements of the Safety Objectives for Electrical Equipment Designed for Use within Certain Voltage Limits (LVD - 2006/95/EC).

Endorsement notice

The text of the International Standard IEC 61347-1:2015 was approved by CENELEC as a European Standard without any modification.

In the official version, for Bibliography, the following notes have to be added for the standards indicated:

| | | |
|--------------------------|------|--------------------------------------|
| IEC 60038 | NOTE | Harmonized as EN 60038. |
| IEC 60155:1993 | NOTE | Harmonized as EN 60155:1995. |
| IEC 60364-4-44 | NOTE | Harmonized as HD 60364-4-444. |
| IEC 60598 (Series) | NOTE | Harmonized as EN 60598 (Series). |
| IEC 60664-3 | NOTE | Harmonized as EN 60664-3. |
| IEC 60925:1989 | NOTE | Harmonized as EN 60925:1991. |
| IEC 60925:1989/AMD1:1996 | NOTE | Harmonized as EN 60925:1991/A1:1996. |
| IEC 60925:1989/AMD2:2001 | NOTE | Harmonized as EN 60925:1991/A2:2001. |
| IEC 60927:2007 | NOTE | Harmonized as EN 60927:2007. |
| IEC 60927:2007/AMD1:2013 | NOTE | Harmonized as EN 60927:2007/A1:2013. |

| | | |
|------------------------------|------|------------------------------------------|
| IEC 60929:2006 | NOTE | Harmonized as EN 60929:2006. |
| IEC 60950-1 | NOTE | Harmonized as EN 60950-1. |
| IEC 60990:1999 | NOTE | Harmonized as EN 60990:1999. |
| IEC 61047:2004 | NOTE | Harmonized as EN 61047:2004. |
| IEC 61347-2-1:2000 | NOTE | Harmonized as EN 61347-2-1:2001. |
| IEC 61347-2-1:2000/AMD1:2005 | NOTE | Harmonized as EN 61347-2-1:2001/A1:2006. |
| IEC 61347-2-2:2011 | NOTE | Harmonized as EN 61347-2-2:2012. |
| IEC 62384 | NOTE | Harmonized as EN 62384. |

Annex ZA (normative)

Normative references to international publications with their corresponding European publications

The following documents, in whole or in part, are normatively referenced in this document and are indispensable for its application. For dated references, only the edition cited applies. For undated references, the latest edition of the referenced document (including any amendments) applies.

NOTE 1 When an International Publication has been modified by common modifications, indicated by (mod), the relevant EN/HD applies.

NOTE 2 Up-to-date information on the latest versions of the European Standards listed in this annex is available here: www.cenelec.eu.

| <u>Publication</u> | <u>Year</u> | <u>Title</u> | <u>EN/HD</u> | <u>Year</u> |
|--------------------|-------------|-----------------------------------------------------------------------------------------------------------------------------------------------------------------------------------------|-------------------|-------------|
| IEC 60065 (mod) | 2001 | Audio, video and similar electronic apparatus - Safety requirements | EN 60065 | 2002 |
| - | - | | +corrigendum Mar. | 2006 |
| - | - | | +corrigendum Aug. | 2007 |
| - | - | | +A11 | 2008 |
| - | - | | +A12 | 2011 |
| IEC 60068-2-14 | 2009 | Environmental testing -- Part 2-14: Tests - Test N: Change of temperature | EN 60068-2-14 | 2009 |
| IEC 60081 | - | Double-capped fluorescent lamps - Performance specifications | EN 60081 | - |
| IEC 60085 | 2007 | Electrical insulation - Thermal evaluation and designation | EN 60085 | 2008 |
| IEC 60112 | 2003 | Method for the determination of the proof and the comparative tracking indices of solid insulating materials | EN 60112 | 2003 |
| +A1 | 2009 | | +A1 | 2009 |
| IEC 60216 | series | Electrical insulating materials - Thermal endurance properties -- Part 1: Ageing procedures and evaluation of test results | EN 60216 | series |
| IEC 60317-0-1 | 2013 | Specifications for particular types of winding wires -- Part 0-1: General requirements - Enamelled round copper wire | EN 60317-0-1 | 2014 |
| IEC 60384-14 | - | Fixed capacitors for use in electronic equipment -- Part 14: Sectional specification - Fixed capacitors for electromagnetic interference suppression and connection to the supply mains | EN 60384-14 | - |
| IEC 60417 | - | Graphical symbols for use on equipment. Index, survey and compilation of the single sheets. | HD 243 S12 | - |
| - | - | | +corrigendum Oct. | - |
| +A1 | 1979 | | - | - |
| IEC 60449 | 1973 | Voltage bands for electrical installations of buildings | HD 193 S2 | 1982 |
| IEC 60529 | 1989 | Degrees of protection provided by enclosures (IP Code) | EN 60529 | 1991 |
| - | - | | +corrigendum May | 1993 |
| +A1 | 1999 | | +A1 | 2000 |
| +A2 | 2013 | | +A2 | 2013 |
| IEC 60598-1 (mod) | 2014 | Luminaires -- Part 1: General requirements and tests | EN 60598-1 | 2015 |

| | | | | |
|----------------|--------|---------------------------------------------------------------------------------------------------------------------------------------------------------------------------------------------------------------|-------------------|--------|
| IEC 60598-2 | series | Luminaires -- Part 2: Particular requirements | EN 60598-2 | series |
| | | -- Section 1: Fixed general purpose luminaires | | |
| IEC 60664-1 | 2007 | Insulation coordination for equipment within low-voltage systems -- Part 1: Principles, requirements and tests | EN 60664-1 | 2007 |
| IEC 60664-4 | 2005 | Insulation coordination for equipment within low-voltage systems -- Part 4: Consideration of high-frequency voltage stress | EN 60664-4 | 2006 |
| - | - | | +corrigendum Oct. | 2006 |
| IEC 60691 | 2002 | Thermal-links - Requirements and application guide | EN 60691 | 2003 |
| IEC 60695-2-10 | - | Fire hazard testing -- Part 2-10: Glowing/hot-wire based test methods - Glow-wire apparatus and common test procedure | EN 60695-2-10 | - |
| IEC 60695-11-5 | - | Fire hazard testing -- Part 11-5: Test flames - Needle-flame test method - Apparatus, confirmatory test arrangement and guidance | EN 60695-11-5 | - |
| IEC 60730-2-3 | - | Automatic electrical controls for household and similar use -- Part 2-3: Particular requirements for thermal protectors for ballasts for tubular fluorescent lamps | EN 60730-2-3 | - |
| IEC 60884-2-4 | - | Plugs and socket-outlets for household and similar purposes -- Part 2-4: Particular requirements for plugs and socket-outlets for SELV | | - |
| IEC 60901 | - | Single-capped fluorescent lamps - Performance specifications | EN 60901 | - |
| IEC 60906-3 | - | IEC System of plugs and socket-outlets for household and similar purposes -- Part 3: SELV plugs and socket-outlets, 16 A 6V, 12 V, 24 V, 48 V, a.c. and d.c. | | - |
| IEC 60921 | 2004 | Ballasts for tubular fluorescent lamps - Performance requirements | EN 60921 | 2004 |
| +A1 | 2006 | | +A1 | 2006 |
| IEC 60923 | 2005 | Auxiliaries for lamps - Ballasts for discharge lamps (excluding tubular fluorescent lamps) - Performance requirements | EN 60923 | 2005 |
| IEC 60950-1 | - | Information technology equipment - Safety -- Part 1: General requirements | EN 60950-1 | - |
| - | - | | +A11 | - |
| - | - | | +A12 | - |
| - | - | | +AC | - |
| IEC 61180-1 | 1992 | High-voltage test techniques for low-voltage equipment -- Part 1: Definitions, test and procedure requirements | EN 61180-1 | 1994 |
| IEC 61189-2 | 2006 | Test methods for electrical materials, printed boards and other interconnection structures and assemblies -- Part 2: Test methods for materials for interconnection structures | EN 61189-2 | 2006 |
| IEC 61249-2 | series | Materials for printed boards and other interconnecting structures -- Part 2-1: Reinforced base materials, clad and unclad - Phenolic cellulose paper reinforced laminated sheets, economic grade, copper-clad | EN 61249-2 | series |
| IEC 61347-2 | series | Lamp controlgear -- Part 2-1: Particular requirements for starting devices (other than glow starters) | EN 61347-2 | series |
| - | - | | +corrigendum Jul. | - |
| - | - | | +corrigendum Dec. | - |

| | | | | |
|----------------|------|-----------------------------------------------------------------------------------------------------------------------------------------------------------------------------------------------------------------------------------------------------------------|-------------------|------|
| IEC 61347-2-8 | - | Lamp controlgear -- Part 2-8: Particular requirements for ballasts for fluorescent lamps | EN 61347-2-8 | - |
| - | - | | +corrigendum Jul. | - |
| - | - | | +corrigendum Dec. | - |
| IEC 61347-2-9 | 2012 | Lamp controlgear -- Part 2-9: Particular requirements for electromagnetic controlgear for discharge lamps (excluding fluorescent lamps) | EN 61347-2-9 | 2013 |
| IEC 61558-1 | 2005 | Safety of power transformers, power supplies, reactors and similar products -- Part 1: General requirements and tests | EN 61558-1 | 2005 |
| - | - | | +corrigendum Aug. | 2006 |
| IEC 61558-2-6 | 2009 | Safety of transformers, reactors, power supply units and similar products for supply voltages up to 1 100 V -- Part 2-6: Particular requirements and tests for safety isolating transformers and power supply units incorporating safety isolating transformers | EN 61558-2-6 | 2009 |
| IEC 61558-2-16 | 2009 | Safety of transformers, reactors, power supply units and similar products for voltages up to 1 100 V -- Part 2-16: Particular requirements and tests for switch mode power supply units and transformers for switch mode power supply units | EN 61558-2-16 | 2009 |
| ISO 4046-4 | 2002 | Paper, board, pulps and related terms - Vocabulary -- Part 4: Paper and board grades and converted products | - | - |

CONTENTS

| | |
|-----------------------------------------------------------------------------------------------------------|----|
| FOREWORD..... | 9 |
| INTRODUCTION..... | 11 |
| 1 Scope..... | 12 |
| 2 Normative references | 12 |
| 3 Terms and definitions | 14 |
| 4 General requirements | 22 |
| 5 General notes on tests | 22 |
| 6 Classification..... | 23 |
| 7 Marking | 24 |
| 7.1 Items to be marked | 24 |
| 7.2 Durability and legibility of marking..... | 26 |
| 8 Terminals | 26 |
| 9 Earthing..... | 26 |
| 9.1 Provisions for protective earthing (Symbol: IEC 60417-5019 (2006-08))..... | 26 |
| 9.2 Provisions for functional earthing (Symbol: IEC 60417-5018 (2011-07))..... | 27 |
| 9.3 Lamp controlgear with conductors for protective earthing by tracks on printed circuit boards | 27 |
| 9.4 Earthing of built-in lamp controlgear..... | 27 |
| 9.5 Earthing via independent controlgear..... | 27 |
| 9.5.1 Earth connection to other equipment | 27 |
| 9.5.2 Earthing of the lamp compartments powered via the independent lamp controlgear | 28 |
| 10 Protection against accidental contact with live parts | 28 |
| 11 Moisture resistance and insulation..... | 29 |
| 12 Electric strength | 30 |
| 13 Thermal endurance test for windings of ballasts | 31 |
| 14 Fault conditions | 35 |
| 15 Construction | 39 |
| 15.1 Wood, cotton, silk, paper and similar fibrous material | 39 |
| 15.2 Printed circuits..... | 39 |
| 15.3 Plugs and socket-outlets used in SELV or ELV circuits | 39 |
| 15.4 Insulation between circuits and accessible parts | 39 |
| 15.4.1 General | 39 |
| 15.4.2 SELV circuits..... | 40 |
| 15.4.3 FELV circuits | 40 |
| 15.4.4 Other circuits..... | 41 |
| 15.4.5 Insulation between circuits and accessible conductive parts | 41 |
| 16 Creepage distances and clearances | 43 |
| 16.1 General..... | 43 |
| 16.2 Creepage distances | 45 |
| 16.2.1 General | 45 |
| 16.2.2 Minimum creepage distances for working voltages | 46 |
| 16.2.3 Creepage distances for working voltages with frequencies above 30 kHz..... | 46 |
| 16.2.4 Compliance with the required creepage distances | 47 |

| | | |
|-------------------------------------------------------------------------------------------------------------------------------|---------------------------------------------------------------------------------------------------------------------------------------------------------|----|
| 16.3 | Clearances | 48 |
| 16.3.1 | General | 48 |
| 16.3.2 | Clearances for working voltages | 49 |
| 16.3.3 | Clearances for ignition voltages and working voltages with higher frequencies..... | 50 |
| 16.3.4 | Compliance with the required clearances..... | 52 |
| 17 | Screws, current-carrying parts and connections..... | 53 |
| 18 | Resistance to heat, fire and tracking..... | 53 |
| 19 | Resistance to corrosion | 54 |
| 20 | No-load output voltage | 54 |
| Annex A (normative) Test to establish whether a conductive part is a live part which may cause an electric shock | | 55 |
| A.1 | General test requirements..... | 55 |
| A.2 | Limits for measured voltages | 55 |
| A.3 | Limits for touch current | 55 |
| Annex B (normative) Particular requirements for thermally protected lamp controlgear | | 56 |
| B.1 | Introductory remark..... | 56 |
| B.2 | General..... | 56 |
| B.3 | Terms and definitions..... | 56 |
| B.4 | General requirements for thermally protected lamp controlgear..... | 57 |
| B.5 | General notes on tests | 57 |
| B.6 | Classification | 57 |
| B.6.1 | General | 57 |
| B.6.2 | According to the class of protection | 57 |
| B.6.3 | According to the type of protection | 57 |
| B.7 | Marking..... | 58 |
| B.8 | Thermal endurance of windings | 58 |
| B.9 | Lamp controlgear heating | 58 |
| B.9.1 | Preselection test..... | 58 |
| B.9.2 | "Class P" thermally protected lamp controlgear | 59 |
| B.9.3 | Temperature declared thermally protected lamp controlgear as specified in IEC 61347-2-8, with a rated maximum case temperature of 130 °C or lower | 60 |
| B.9.4 | Temperature declared thermally protected lamp controlgear as specified in IEC 61347-2-8 with a rated maximum case temperature exceeding 130 °C | 61 |
| B.9.5 | Temperature declared thermally protected lamp controlgear as specified in IEC 61347-2-9 | 62 |
| Annex C (normative) Particular requirements for electronic lamp controlgear with means of protection against overheating..... | | 64 |
| C.1 | General..... | 64 |
| C.2 | Terms and definitions..... | 64 |
| C.3 | General requirements for electronic lamp controlgear with means of protection against overheating | 64 |
| C.4 | General notes on tests | 65 |
| C.5 | Classification | 65 |
| C.6 | Marking..... | 65 |
| C.7 | Limitation of heating | 65 |
| C.7.1 | Pre-selection test..... | 65 |

| | | |
|---------------------|---------------------------------------------------------------------------------------------------|----|
| C.7.2 | Functioning of the protection means | 65 |
| Annex D (normative) | Requirements for carrying out the heating tests of thermally protected lamp controlgear | 67 |
| D.1 | Test enclosure | 67 |
| D.2 | Heating of enclosure | 67 |
| D.3 | Lamp controlgear operating conditions | 67 |
| D.4 | Lamp controlgear position in the enclosure | 67 |
| D.5 | Temperature measurements | 68 |
| Annex E (normative) | Use of constant S other than 4 500 in t_w tests | 69 |
| E.1 | General | 69 |
| E.2 | Procedure A | 69 |
| E.3 | Procedure B | 69 |
| Annex F (normative) | Draught-proof enclosure | 72 |
| Annex G (normative) | Explanation of the derivation of the values of pulse voltages | 73 |
| G.1 | Pulse voltage rise time T | 73 |
| G.2 | Long-duration pulse voltages | 73 |
| G.3 | Short-duration pulse voltages | 73 |
| G.4 | Measurement of short-duration pulse energy | 73 |
| Annex H (normative) | Tests | 79 |
| H.1 | Ambient temperature and test room | 79 |
| H.2 | Supply voltage and frequency | 79 |
| H.2.1 | Test voltage and frequency | 79 |
| H.2.2 | Stability of supply and frequency | 79 |
| H.2.3 | Supply voltage waveform for reference ballast only | 79 |
| H.3 | Electrical characteristics of lamps | 80 |
| H.4 | Magnetic effects | 80 |
| H.5 | Mounting and connection of reference lamps | 80 |
| H.6 | Reference lamp stability | 80 |
| H.7 | Instrument characteristics | 80 |
| H.7.1 | Potential circuits | 80 |
| H.7.2 | Current circuits | 80 |
| H.7.3 | RMS measurements | 81 |
| H.8 | Inverter power sources | 81 |
| H.9 | Reference ballast | 81 |
| H.10 | Reference lamps | 81 |
| H.11 | Test conditions | 81 |
| H.11.1 | Resistance measurement delays | 81 |
| H.11.2 | Electrical resistance of contacts and leads | 81 |
| H.12 | Lamp controlgear heating | 81 |
| H.12.1 | Built-in lamp controlgear | 81 |
| H.12.2 | Independent lamp controlgear | 82 |
| H.12.3 | Integral lamp controlgear | 82 |
| H.12.4 | Test conditions | 83 |
| Annex I (normative) | Additional requirements for built-in magnetic ballasts with double or reinforced insulation | 84 |
| I.1 | General | 84 |
| I.2 | Terms and definitions | 84 |
| I.3 | General requirements | 84 |
| I.4 | General notes on tests | 85 |

| | | |
|-------------------------------------------------------------------------------------------------------------------------------------|----------------------------------------------------------------------------------------------------------------------------------------|-----|
| I.5 | Classification | 85 |
| I.6 | Marking..... | 85 |
| I.7 | Protection against accidental contact with live parts..... | 85 |
| I.8 | Terminals..... | 85 |
| I.9 | Provision for earthing..... | 85 |
| I.10 | Moisture resistance and insulation | 85 |
| I.11 | High-voltage impulse test..... | 85 |
| I.12 | Thermal endurance test for windings of ballasts..... | 86 |
| I.13 | Ballast heating..... | 86 |
| I.14 | Screws, current-carrying parts and connections | 86 |
| I.15 | Creepage distances and clearances..... | 86 |
| I.16 | Resistance to heat and fire | 86 |
| I.17 | Resistance to corrosion | 86 |
| Annex J (normative) Schedule of more onerous requirements | | 87 |
| Annex K (informative) Conformity testing during manufacture | | 88 |
| K.1 | General..... | 88 |
| K.2 | Testing | 88 |
| K.3 | Additional dielectric strength tests for controlgear with protection against pollution by the use of coating or potting material | 90 |
| Annex L (normative) Particular additional requirements for controlgears providing SELV | | 91 |
| L.1 | General..... | 91 |
| L.2 | Terms and definitions..... | 91 |
| L.3 | Classification | 92 |
| L.4 | Marking..... | 92 |
| L.5 | Protection against electric shock..... | 93 |
| L.6 | Heating..... | 93 |
| L.7 | Short-circuit and overload protection..... | 94 |
| L.8 | Insulation resistance and electric strength | 95 |
| L.8.1 | General | 95 |
| L.8.2 | Insulation resistance..... | 95 |
| L.8.3 | Electric strength | 95 |
| L.9 | Construction | 96 |
| L.10 | Components | 96 |
| L.11 | Creepage distances, clearances and distances through insulation | 97 |
| Annex M (informative) Dielectric strength test voltages for controlgear intended for the use in impulse withstand Category III..... | | 98 |
| Annex N (normative) Requirements for insulation materials used for double or reinforced insulation | | 99 |
| N.1 | General..... | 99 |
| N.2 | Reference document..... | 99 |
| N.3 | Terms and definitions..... | 99 |
| N.4 | General requirements | 99 |
| N.4.1 | Material requirements | 99 |
| N.4.2 | Solid insulation | 99 |
| N.4.3 | Thin sheet insulation..... | 99 |
| Annex O (normative) Additional requirements for built-in electronic controlgear with double or reinforced insulation | | 103 |
| O.1 | General..... | 103 |

| | | |
|---------------------------------------------------------------------------------------------------------------------------------------------------------------------------------------------|---------------------------------------------------------------------------------------------------------------------------|-----|
| O.2 | Terms and definitions..... | 103 |
| O.3 | General requirements | 103 |
| O.4 | General notes on tests | 103 |
| O.5 | Classification | 104 |
| O.6 | Marking..... | 104 |
| O.7 | Protection against accidental contact with live parts..... | 104 |
| O.8 | Terminals..... | 104 |
| O.9 | Provision for earthing..... | 104 |
| O.10 | Moisture resistance and insulation | 104 |
| O.11 | Electric strength..... | 104 |
| O.12 | Thermal endurance of windings | 104 |
| O.13 | Fault conditions | 104 |
| O.14 | Construction | 105 |
| O.15 | Creepage distances and clearances..... | 105 |
| O.16 | Screws, current-carrying parts and connections | 105 |
| O.17 | Resistance to heat and fire | 105 |
| O.18 | Resistance to corrosion | 105 |
| Annex P (normative) Creepage distances and clearances and distance through isolation (DTI) for lamp controlgear which are protected against pollution by the use of coating or potting..... | | 106 |
| P.1 | General..... | 106 |
| P.2 | Creepage distances | 106 |
| P.2.1 | General | 106 |
| P.2.2 | Minimum creepage distances for working voltages and rated voltage with frequencies up to 30 kHz..... | 106 |
| P.2.3 | Creepage distances for working voltages with frequencies above 30 kHz..... | 106 |
| P.2.4 | Compliance with the required creepage distances | 107 |
| P.3 | Distance through isolation..... | 108 |
| P.3.1 | General | 108 |
| P.3.2 | Compliance tests | 109 |
| P.3.3 | Preconditioning of the lamp controlgear..... | 109 |
| P.3.4 | Electrical tests after conditioning | 109 |
| Annex Q (informative) Example for U_p calculation | | 111 |
| Annex R (informative) Concept of creepage distances and clearances..... | | 112 |
| R.1 | Basic concept considerations..... | 112 |
| R.1.1 | Creepage distances | 112 |
| R.1.2 | Clearances | 112 |
| R.2 | Why setting up tables?..... | 113 |
| Annex S (informative) Examples of controlgear insulation coordination | | 114 |
| Annex T (informative) Creepage distances and clearances for controlgear with a higher degree of availability (impulse withstand category III)..... | | 115 |
| T.1 | General..... | 115 |
| T.2 | Clearances for working voltages of lamp controlgear not protected against pollution by coating or potting materials | 115 |
| T.3 | Clearances for working voltages of lamp controlgear protected against pollution by coating or potting | 116 |
| T.4 | Distances through insulation – Particular additional requirements for controlgear providing SELV | 116 |
| Bibliography..... | | 118 |

| | |
|------------------------------------------------------------------------------------------------------------------------------------------------------------------------|-----|
| Figure 1 – Relation between winding temperature and endurance test duration | 33 |
| Figure 2 – Test circuit for controlgear | 38 |
| Figure 3 – Example of a controlgear insulation related to Table 6 | 42 |
| Figure 4 – Application of Table 7 and Table 8 | 45 |
| Figure 5 – Application of Table 9, Table 10 and Table 11 | 48 |
| Figure 6 – Application of Table 10 and Table 11 | 49 |
| Figure B.1 – Test circuit for thermally protected lamp controlgear | 62 |
| Figure D.1 – Example of heating enclosure for thermally protected ballasts | 68 |
| Figure E.1 – Assessment of claimed value of S | 71 |
| Figure G.1 – Circuit for measuring short-duration pulse energy | 76 |
| Figure G.2 – Suitable circuit for producing and applying long-duration pulses | 78 |
| Figure H.1 – Test arrangement for heating test | 83 |
| Figure N.1 – Test arrangement for checking mechanical withstanding of insulating materials in thin sheet layers | 102 |
| Figure Q.1 – Example for the calculation of U_p | 111 |
| Figure S.1 – Example of schematic drawings, showing the different controlgear insulation coordination | 114 |
| | |
| Table 1 – Required rated impulse withstand voltage of equipment | 21 |
| Table 2 – Working voltage and U_{Out} steps | 25 |
| Table 3 – Electric strength test voltage | 30 |
| Table 4 – Theoretical test temperatures for ballasts subjected to an endurance test duration of 30 days | 34 |
| Table 5 – Minimum creepage distance on printed circuit board | 37 |
| Table 6 – Insulation requirements between active parts and accessible conductive parts | 43 |
| Table 7 – Minimum creepage distances for working voltage | 46 |
| Table 8 – Minimum value of creepage distances for sinusoidal or non-sinusoidal working voltages at different frequency ranges; basic or supplementary insulation | 47 |
| Table 9 – Minimum clearances for working voltages | 49 |
| Table 10 – Minimum distances of clearances for sinusoidal or non-sinusoidal voltages; inhomogeneous field conditions; basic or supplementary insulation | 51 |
| Table 11 – Minimum distances of clearances for sinusoidal or non-sinusoidal voltages; inhomogeneous field conditions; reinforced insulation | 52 |
| Table B.1 – Thermal protection operation | 60 |
| Table B.2 – Thermal protection operation | 61 |
| Table G.1 – Component values for measurement of pulse energy | 76 |
| Table K.1 – Minimum values for electrical tests | 89 |
| Table L.1 – Symbols for marking if marking is used | 93 |
| Table L.2 – Values of temperatures in normal use | 94 |
| Table L.3 – Values of insulation resistances | 95 |
| Table L.4 – Table of dielectric strength test voltages for controlgears intended for use in impulse withstand Category II | 96 |
| Table L.5 – Distances through insulation (DTI) for the impulse withstand category II / material group IIIa (175 CTI < 400) | 97 |

| | |
|--------------------------------------------------------------------------------------------------------------------------------------------------------------------------|-----|
| Table M.1 – Table of dielectric strength test voltages for controlgears intended for use in impulse withstand Category III | 98 |
| Table N.1 – Electric strength test voltage required during the mandrel test | 101 |
| Table P.1 – Minimum creepage distances for working voltages and rated voltages with frequencies up to 30 kHz | 106 |
| Table P.2 – Minimum value of creepage distances for sinusoidal or non-sinusoidal working voltages at different frequency ranges; basic or supplementary insulation | 107 |
| Table P.3 – Impulse withstand test voltage for products of impulse withstand category II | 110 |
| Table T.1 – Minimum clearances for working voltages – Impulse withstand category III | 115 |
| Table T.2 – Impulse withstand test voltages of impulse withstand category III for lamp controlgear protected against pollution by coating or potting material | 116 |
| Table T.3 – Distances through insulation (DTI) for the impulse withstand category III/material group IIIa (175 CTI < 400) | 117 |

INTERNATIONAL ELECTROTECHNICAL COMMISSION

LAMP CONTROLGEAR –**Part 1: General and safety requirements****FOREWORD**

- 1) The International Electrotechnical Commission (IEC) is a worldwide organization for standardization comprising all national electrotechnical committees (IEC National Committees). The object of IEC is to promote international co-operation on all questions concerning standardization in the electrical and electronic fields. To this end and in addition to other activities, IEC publishes International Standards, Technical Specifications, Technical Reports, Publicly Available Specifications (PAS) and Guides (hereafter referred to as "IEC Publication(s)"). Their preparation is entrusted to technical committees; any IEC National Committee interested in the subject dealt with may participate in this preparatory work. International, governmental and non-governmental organizations liaising with the IEC also participate in this preparation. IEC collaborates closely with the International Organization for Standardization (ISO) in accordance with conditions determined by agreement between the two organizations.
- 2) The formal decisions or agreements of IEC on technical matters express, as nearly as possible, an international consensus of opinion on the relevant subjects since each technical committee has representation from all interested IEC National Committees.
- 3) IEC Publications have the form of recommendations for international use and are accepted by IEC National Committees in that sense. While all reasonable efforts are made to ensure that the technical content of IEC Publications is accurate, IEC cannot be held responsible for the way in which they are used or for any misinterpretation by any end user.
- 4) In order to promote international uniformity, IEC National Committees undertake to apply IEC Publications transparently to the maximum extent possible in their national and regional publications. Any divergence between any IEC Publication and the corresponding national or regional publication shall be clearly indicated in the latter.
- 5) IEC itself does not provide any attestation of conformity. Independent certification bodies provide conformity assessment services and, in some areas, access to IEC marks of conformity. IEC is not responsible for any services carried out by independent certification bodies.
- 6) All users should ensure that they have the latest edition of this publication.
- 7) No liability shall attach to IEC or its directors, employees, servants or agents including individual experts and members of its technical committees and IEC National Committees for any personal injury, property damage or other damage of any nature whatsoever, whether direct or indirect, or for costs (including legal fees) and expenses arising out of the publication, use of, or reliance upon, this IEC Publication or any other IEC Publications.
- 8) Attention is drawn to the Normative references cited in this publication. Use of the referenced publications is indispensable for the correct application of this publication.
- 9) Attention is drawn to the possibility that some of the elements of this IEC Publication may be the subject of patent rights. IEC shall not be held responsible for identifying any or all such patent rights.

International Standard IEC 61347-1 has been prepared by subcommittee 34C: Auxiliaries for lamps, of IEC technical committee 34: Lamps and related equipment.

This third edition cancels and replaces the second edition published in 2007, Amendment 1:2010 and Amendment 2:2012. This edition constitutes a technical revision.

This edition includes the following significant technical changes with respect to the previous edition:

- a) additional marking requirements;
- b) additional requirements for creepage distances and clearances:
 - for working voltages with operating frequencies up to 30 kHz;
 - for working voltages with higher operating frequencies than 30 kHz;
 - for impulse and resonance voltages ignition;
 - for basic, supplementary and reinforced insulation;

- for insulation between circuits;
for coated or potted controlgear;
- c) modification of definition of ELV and FELV;
 - d) modification of schematic drawing, showing the different controlgear classification and insulation requirements;
 - e) scope extension;
 - f) new Annex A: test to establish whether a conductive part is a live part which may cause an electric shock;
 - g) new Annex M: creepage distances and clearances for controlgear where a higher degree of availability (impulse withstand category III) may be requested;
 - h) new Annex Q: example for U_p calculation;
 - i) new Annex P: creepage distances and clearances and distance through isolation (DTI) for lamp controlgear which are protected against pollution by the use of coating or potting;
 - j) new Annex R: concept of creepage distances and clearances.

The text of this standard is based on the following documents:

| FDIS | Report on voting |
|---------------|------------------|
| 34C/1118/FDIS | 34C/1135/RVD |

Full information on the voting for the approval of this standard can be found in the report on voting indicated in the above table.

This publication has been drafted in accordance with the ISO/IEC Directives, Part 2.

This Part 1 is to be used in conjunction with the appropriate Part 2, which contains clauses to supplement or modify the corresponding clauses in Part 1, to provide the relevant requirements for each type of product.

NOTE In this standard, the following print types are used.

- Requirements proper: in roman type.
- *Test specifications: in italic type.*
- Explanatory matter: in smaller roman type.

A list of all parts of the IEC 61347 series, published under the general title *Lamp controlgear*, can be found on the IEC website.

The committee has decided that the contents of this publication will remain unchanged until the stability date indicated on the IEC web site under "<http://webstore.iec.ch>" in the data related to the specific publication. At this date, the publication will be

- reconfirmed,
- withdrawn,
- replaced by a revised edition, or
- amended.

IMPORTANT – The “colour inside” logo on the cover page of this publication indicates that it contains colours which are considered to be useful for the correct understanding of its contents. Users should therefore print this publication using a colour printer.

INTRODUCTION

This part of IEC 61347 provides a set of general and safety requirements and tests which are considered to be generally applicable to most types of lamp controlgear and which can be called up as required by the different parts that make up IEC 61347-2. This Part 1 is thus not to be regarded as a specification in itself for any type of lamp controlgear, and its provisions apply only to particular types of lamp controlgear, to the extent determined by the appropriate Part 2 of IEC 61347.

The parts which make up IEC 61347-2, in referring to any of the clauses of this part, specify the extent to which such a clause is applicable and the order in which the tests are to be performed; they also include additional requirements as necessary. The order in which the clauses of this part are numbered has no particular significance, as the order in which their provisions apply is determined for each type of lamp controlgear by the appropriate Part 2 of the IEC 61347-2 series. All such parts are self-contained and therefore do not contain references to each other.

Where the requirements of any of the clauses of this part of IEC 61347 are referred to in the various parts that make up IEC 61347-2 by the phrase "The requirements of clause n of IEC 61347-1 apply", this phrase will be interpreted as meaning that all requirements of the clause in question of Part 1 apply, except any which are clearly inapplicable to the particular type of lamp controlgear covered by the Part 2 concerned.

Lamp controlgear which complies with the text of this standard will not necessarily be judged to comply with the safety principles of the standard if, when examined and tested, it is found to have other features which impair the level of safety covered by these requirements.

Lamp controlgear employing materials or having forms of construction differing from those detailed in the requirements of this standard may be examined and tested according to the intent of the requirement and, if found to be substantially equivalent, may be judged to comply with the safety principles of the standard.

Performance requirements for lamp controlgear are the subject of IEC 60921, IEC 60923, IEC 60925, IEC 60927, IEC 60929, IEC 61047 and IEC 62384 as appropriate for the type of lamp controlgear.

Safety requirements ensure that electrical equipment constructed in accordance with these requirements does not endanger the safety of persons, domestic animals or property when properly installed and maintained and used in applications for which it was intended.

Requirements for electronic lamp controlgear for other types of lamps will be the subject of a separate standard, as the need arises.

Controlgear can consist of a printed circuit board and may incorporate the following:

- controlgear;
- lampholder(s);
- switch(es);
- supply terminals.

The lamp controlgear should comply with this standard.

The lampholders(s), switch(es) and supply terminals should comply with their own standards.

LAMP CONTROLGEAR –

Part 1: General and safety requirements

1 Scope

This part of IEC 61347 specifies general and safety requirements for lamp controlgear for use on d.c. supplies up to 250 V and/or a.c. supplies up to 1 000 V at 50 Hz or 60 Hz.

This standard also covers lamp controlgear for lamps which are not yet standardized.

Tests dealt with in this standard are type tests. Requirements for testing individual lamp controlgear during production are not included.

Requirements for semi-luminaires are given in IEC 60598-1:2014 (see definition 1.2.60).

Particular requirements for controlgears providing safety extra low voltage (from now on SELV) are given in Annex L.

It can be expected that lamp control gear which comply with this standard will not compromise safety between 90 % and 110 % of their rated supply voltage in independent use and when operated in luminaires complying with the safety standard IEC 60598-1 and the relevant part IEC 60598-2-xx and with lamps complying with the relevant lamp standards. Performance requirements may require tighter limits.

2 Normative references

The following documents, in whole or in part, are normatively referenced in this document and are indispensable for its application. For dated references, only the edition cited applies. For undated references, the latest edition of the referenced document (including any amendments) applies.

IEC 60065:2001¹, *Audio, video and similar electronic apparatus – Safety requirements*

IEC 60068-2-14:2009, *Environmental testing – Part 2-14: Tests – Test N: Change of temperature*

IEC 60081, *Double-capped fluorescent lamps – Performance specifications*

IEC 60085:2007, *Electrical insulation – Thermal classification and designation*

IEC 60112:2003, *Method for the determination of the proof and the comparative tracking indices of solid insulating materials*
IEC 60112:2003/AMD1:2009

IEC 60216 (all parts), *Electrical insulating materials – Thermal endurance properties*

IEC 60317-0-1:2013, *Specifications for particular types of windings wires – Part 0-1: General requirements – Enamelled round copper wire*

¹ Seventh edition. This edition has been replaced in 2014 by IEC 60065:2014.

IEC 60384-14, *Fixed capacitors for use in electronic equipment – Part 14: Sectional specification: Fixed capacitors for electromagnetic interference suppression and connection to the supply mains*

IEC 60417, *Graphical symbols for use on equipment*. Available at <http://www.graphical-symbols.info/equipment>

IEC 60449:1973, *Voltage bands for electrical installations of buildings*
IEC 60449:1973/AMD1:1979

IEC 60529:1989, *Degrees of protection provided by enclosures (IP Code)*
IEC 60529:1989/AMD1:1999
IEC 60529:1989/AMD2:2013

IEC 60598-1:2014, *Luminaires – Part 1: General requirements and tests*

IEC 60598-2, (all parts), *Luminaires – Part 2: Particular requirements*

IEC 60664-1:2007, *Insulation coordination for equipment within low-voltage systems – Part 1: Principles, requirements and tests*

IEC 60664-4:2005, *Insulation coordination for equipment within low-voltage systems – Part 4: Consideration of high-frequency voltage stress*

IEC 60691:2002, *Thermal-links – Requirements and application guide*

IEC 60695-2-10, *Fire hazard testing – Part 2-10: Glowing/hot-wire based test methods – Glow-wire apparatus and common test procedure*

IEC 60695-11-5, *Fire hazard testing – Part 11-5: Test flames – Needle-flame test method – Apparatus, confirmatory test arrangement and guidance*

IEC 60730-2-3, *Automatic electrical controls for household and similar use – Part 2: Particular requirements for thermal protectors for ballasts for tubular fluorescent lamps*

IEC 60884-2-4, *Plugs and socket-outlets for household and similar purposes – Part 2-4: Particular requirements for plugs and socket outlets for SELV*

IEC 60901, *Single-capped fluorescent lamps – Performance specifications*

IEC 60906-3, *IEC System of plugs and socket-outlets for household and similar purposes – Part 3: SELV plugs and socket-outlets, 16 A 6 V, 12 V, 24 V, 48 V, a.c. and d.c.*

IEC 60921:2004, *Ballasts for tubular fluorescent lamps – Performance requirements*
IEC 60921:2004/AMD1:2006

IEC 60923:2005, *Auxiliaries for lamps – Ballasts for discharge lamps (excluding tubular fluorescent lamps) – Performance requirements*

IEC 60950-1, *Information technology equipment – Safety – Part 1: General requirements*

IEC 61180-1:1992, *High-voltage test techniques for low voltage equipment – Part 1: Definitions, test and procedure requirements*

IEC 61189-2:2006, *Test methods for electrical materials, printed boards and other interconnection structures and assemblies – Part 2: Test methods for materials for interconnection structures*

IEC 61249-2 (all parts), *Materials for printed boards and other interconnecting structures*

IEC 61347-2 (all parts), *Lamp controlgear – Part 2: Particular requirements*

IEC 61347-2-8, *Lamp controlgear – Part 2-8: Particular requirements for ballasts for fluorescent lamps*

IEC 61347-2-9:2012, *Lamp controlgear – Part 2-9: Particular requirements electromagnetic controlgear for discharge lamps (excluding fluorescent lamps)*

IEC 61558-1:2005, *Safety of power transformers, power supplies, reactors and similar products – Part 1: General requirements and tests*

IEC 61558-2-6:2009, *Safety of transformers, reactors, power supply units and similar products for supply voltages up to 1 100 V – Part 2-6: Particular requirements and tests for safety isolating transformers and power supply units incorporating safety isolating transformers*

IEC 61558-2-16:2009, *Safety of transformers, reactors, power supply units and similar products for supply voltages up to 1 100 V – Part 2-16: Particular requirements and tests for switch mode power supply units and transformers for switch mode power supply units*

ISO 4046-4:2002, *Paper, board, pulp and related terms – Vocabulary – Part 4: Paper and board grades and converted products*

3 Terms and definitions

For the purposes of document, the following terms and definitions apply.

3.1

lamp controlgear

one or more components between the supply and one or more lamps which may serve to transform the supply voltage, limit the current of the lamp(s) to the required value, provide starting voltage and preheating current, prevent cold starting, correct power factor or reduce radio interference

3.1.1

built-in lamp controlgear

lamp controlgear generally designed to be built into a luminaire, a box, an enclosure or the like and not intended to be mounted outside a luminaire, etc. without special precautions

Note 1 to entry: The controlgear compartment in the base of a road lighting column is considered to be an enclosure.

3.1.2

independent lamp controlgear

lamp controlgear consisting of one or more separate elements so designed that it can be mounted separately outside a luminaire, with protection according to the marking of the lamp controlgear and without any additional enclosure

Note 1 to entry: This may consist of a built-in lamp controlgear housed in a suitable enclosure which provides all the necessary protection according to its markings.

3.1.3

integral lamp controlgear

lamp controlgear which forms a non-replaceable part of a luminaire and which cannot be tested separately from the luminaire

3.2

ballast

unit inserted between the supply and one or more discharge lamps which by means of inductance, capacitance, or a combination of inductance and capacitance, serves mainly to limit the current of the lamp(s) to the required value

Note 1 to entry: It may also include means for transforming the supply voltage and arrangements which help provide starting voltage and pre-heating current.

3.2.1

d.c. supplied electronic ballast

d.c. to a.c. inverter using semiconductor devices which may include stabilizing elements for supplying power to one or more fluorescent lamps

3.2.2

reference ballast

special inductive ballast designed for the purpose of providing comparison standards for use in testing ballasts and for the selection of reference lamps, and essentially characterized by a stable voltage-to-current ratio, which is relatively uninfluenced by variations in current, temperature and magnetic surroundings

Note 1 to entry: See also Annex C of IEC 60921:2004 and Annex A of IEC 60923:2005.

3.2.3

controllable ballast

electronic ballast whose lamp operating characteristics can be changed by means of a signal via mains or extra control input

3.3

reference lamp

lamp selected for testing ballasts which, when associated with a reference ballast, has electrical characteristics which are close to the rated values as stated in the relevant lamp standard

3.4

calibration current of a reference ballast

value of the current on which are based the calibration and control of the reference ballast

Note 1 to entry: Such a current should preferably be approximately equal to the rated running current of the lamps for which the reference ballast is suitable.

3.5

supply voltage

voltage applied to the complete circuit of lamp(s) and lamp controlgear

3.6

working voltage

highest r.m.s. voltage which may occur across any insulation at rated supply voltage, transients being neglected, in open-circuit conditions or during normal operation

3.7

design voltage

voltage declared by the manufacturer to which all the lamp controlgear characteristics are related

Note 1 to entry: This value is not less than 85 % of the maximum value of the rated voltage range.

3.8

voltage range

range of supply voltage over which the ballast is intended to be operated

3.9

rated no-load output voltage

output voltage when the ballast is connected to rated supply voltage at rated frequency, with no load on the output, transient and starting phase being neglected

3.10

supply current

current supplied to the complete circuit of lamp(s) and lamp controlgear

3.11

live part

conductive part which may cause an electric shock in normal use

Note 1 to entry: The neutral conductor is, however, regarded as a live part

Note 2 to entry: The test to determine whether or not a conductive part is a live part which may cause an electric shock is given in Annex A.

3.12

type test

test or series of tests made on a type test sample for the purpose of checking compliance of the design of a given product with the requirements of the relevant standard

3.13

type test sample

sample consisting of one or more similar units submitted by the manufacturer or responsible vendor for the purpose of a type test

3.14

circuit power factor

λ

power factor of the combination of lamp controlgear and the lamp or lamps for which the lamp controlgear is designed

3.15

high power factor ballast

ballast having a circuit power factor of at least 0,85 (leading or lagging)

Note 1 to entry: The value 0,85 takes into account the distortion of the current waveform.

Note 2 to entry: For North America, a high power factor is defined as a power factor of at least 0,9.

3.16

rated maximum temperature

t_c

highest permissible temperature which may occur on the outer surface (at the indicated place, if marked) under normal operating conditions and at the rated voltage or the maximum of the rated voltage range

3.17

rated maximum operating temperature of a lamp controlgear winding

t_w

winding temperature assigned by the manufacturer as the highest temperature at which a 50 Hz/60 Hz lamp controlgear may be expected to have a service life of at least 10 years' continuous operation

3.18**rectifying effect**

effect which may occur at the end of lamp life when one cathode is either broken or has insufficient electron emission, resulting in the arc current being constantly unequal in consecutive half-cycles

3.19**test duration of endurance test***D*

optional duration of the endurance test on which the temperature conditions are based

3.20**degradation of insulation of a ballast winding***S*

constant which determines the degradation of ballast insulation

3.21**ignitor**

device intended to generate voltage pulses to start discharge lamps and which does not provide for the preheating of electrodes

Note 1 to entry: The element that releases the starting voltage pulse may be either triggered or non-triggered.

3.22**protective earth
protective ground**

terminal to which are connected parts which are connected to earth for safety reasons

Note 1 to entry: The source for this symbol is IEC 60417-5019 (2006-08).

3.23**functional earth
functional ground**

terminal to which are connected parts which may be necessary to connect to earth for reasons other than safety

Note 1 to entry: The source for this symbol is IEC 60417-5018 (2011'07).

Note 2 to entry: In some cases, functional earthing may be necessary to facilitate starting and/or to avoid radio interference.

3.24**frame
chassis**

terminal whose potential is taken as reference

Note 1 to entry: The source for this symbol is IEC 60417-5020 (2002-10).

3.25

control terminals

connections, other than power supply terminals, to the electronic ballast, which are used to exchange information with the ballast

Note 1 to entry: The power supply terminals can also be used to exchange information with the ballast.

3.26

control signal

signal, which may be an a.c. or d.c. voltage, and which by analogue, digital or other means may be modulated to exchange information with the ballast

3.27

extra-low voltage

ELV

voltage which does not exceed 50 V a.c. or 120 V ripple free d.c. between conductors or between any conductor and earth

Note 1 to entry: "Ripple free" is conventionally defined for sinusoidal ripple voltage as a ripple content of not more than 10 % r.m.s.: the maximum peak value does not exceed 140 V for a nominal 120 V ripple-free d.c. system.

Note 2 to entry: This voltage corresponds to the voltage band I of IEC 60449.

3.27.1

safety extra low voltage

SELV

ELV in a circuit which is isolated from the mains supply by insulation not less than that between the primary and secondary circuits of a safety isolating transformer according to IEC 61558-2-6

Note 1 to entry: Maximum voltage lower than 50 V a.c. r.m.s. or 120 V ripple free d.c. may be specified in particular requirements, especially when direct contact with current-carrying parts is allowed.

Note 2 to entry: The voltage limit should not be exceeded at any load between full loads and no-load when the source is a safety isolation transformer.

Note 3 to entry: "Ripple free" is conventionally an r.m.s. ripple voltage not more than 10 % of the d.c. component: the maximum peak value does not exceed 140 V for a nominal 120 V ripple free d.c. system and 70 V for a nominal 60 V ripple free d.c. system.

3.27.2

functional extra low voltage circuit

FELV

ELV voltage for functional reason and not fulfilling the requirements for SELV (or PELV)

Note 1 to entry: FELV has simple separation from LV.

Note 2 to entry: A FELV circuit is not safe to touch and may be connected to protective earth.

[SOURCE: IEC 61558-1:2005, 3.7.19, modified]

3.28

body

term used in this standard as a general term which includes all accessible metal parts, shafts, handles, knobs, grips and the like, accessible metal fixing screws and metal foil applied on accessible surfaces of insulating material and does not include non-accessible metal parts

3.29

class I lamp controlgear

independent controlgear in which protection against electric shock does not rely on basic insulation only, but which includes an additional safety precaution in such a way that means are provided for the connection of accessible conductive parts to the protective (earthing)

conductor in the fixed wiring of the installation in such a way that accessible conductive parts cannot become live in the event of a failure of the basic insulation

Note 1 to entry: Class I lamp independent controlgear may have parts with double or reinforced insulation.

Note 2 to entry: Class I lamp independent controlgear may have parts in which protection against shock relies on operation at safety extra-low voltage (SELV)

3.30

class II lamp controlgear

independent controlgear in which protection against electric shock does not rely on basic insulation only, but in which additional safety precautions such as double insulation or reinforced insulation are provided, there being no provision for protective earthing or reliance upon installation conditions

3.31

class III lamp controlgear

independent controlgear in which protection against electric shock relies on supply at safety extra-low voltage (SELV) and in which voltages higher than those of SELV are not generated

3.32

protective impedance device

component or assembly of components the impedance and construction of which are such as to ensure that steady state touch current and charge are limited to a non-hazardous level

3.33

maximum working voltage

U_{out}

maximum occurring working voltage (r.m.s.) between the output terminals or between the output terminals and earth, during normal or abnormal operating condition

Note 1 to entry: Transients and ignition voltages have to be neglected.

3.34

basic insulation

insulation of parts which provide protection against electrical shock under fault-free conditions

3.35

double insulation

insulation of parts with two layers of insulation which provide protection against electrical shock under single fault condition

3.36

reinforced insulation

insulation of parts which provide a degree of protection as double insulation

3.37

clearance

shortest distance in air between two conductive parts

[SOURCE: IEC 60664-1:2007, 3.2]

3.38

creepage distance

shortest distance along the surface of a solid insulating material between two conductive parts

[SOURCE: IEC 60050:2001, 151.15.50]

3.39**solid insulation**

solid non-conducting material interposed between two conductive parts

[SOURCE: IEC 60664-1:2007, 3.2]

3.40**critical frequency**
 f_{crit}

frequency at which the reduction of the breakdown voltage of a clearance begins (occurs)

3.41**homogeneous field**

electric field which has an essentially constant voltage gradient between electrodes (uniform field), such as that between two spheres where the radius of each sphere is greater than the distance between them

[SOURCE: IEC 60664-1:2007, 3.14]

3.42**inhomogeneous field**

electric field which does not have an essentially constant voltage gradient between electrodes (non-uniform field)

Note 1 to entry: The inhomogeneous field condition of a point-plane electrode configuration is the worst case with regard to voltage withstand capability. It is represented by a point electrode having a 30 μm radius and a plane of 1 m \times 1 m.

[SOURCE: IEC 60664-2-1:2011, 3.16, modified — The second note has been deleted.]

3.43**transients****transient overvoltage**

short duration overvoltage of a few milliseconds or less, oscillatory or non-oscillatory, usually highly damped

Note 1 to entry: The duration of the transient is the time interval in which the voltage exceeds 10 % of its peak value.

[SOURCE: IEC 60050:1987, 604.03.13, modified — The notes have been modified.]

3.44**impulse withstand category**

DEPRECATED: overvoltage category

numeral defining a transient overvoltage condition

Note 1 to entry: The following explanation together with Table 1 is taken from IEC 60364-4-44:2007.

a) Purpose of classification of impulse withstand voltages

Overvoltage categories are defined within electrical installations for the purpose of insulation co-ordination and a related classification of equipment with impulse withstand voltages is provided, see Table 1.

The rated impulse withstand voltage is an impulse withstand voltage assigned by the manufacturer to the equipment or to a part of it, characterizing the specified withstand capability of its insulation against overvoltages (in accordance with 3.9.2 of IEC 60664-1:2007).

b) The impulse withstand voltage is used to classify equipment energized directly from the mains.

Impulse withstand voltages for equipment selected according to the nominal voltage are provided to distinguish different levels of availability of equipment with regard to continuity of service and an acceptable risk of failure. By selection of equipment with a classified impulse withstand voltage; insulation co-ordination can be achieved in the whole installation, reducing the risk of failure to an acceptable level.

Transient overvoltages transmitted by the supply distribution system are not significantly attenuated downstream in most installations.

Table 1 – Required rated impulse withstand voltage of equipment

| Nominal voltage of the installation ^a V | | Impulse withstand voltage for equipment kV ^b | | | |
|----------------------------------------------------------------------------------------|----------------------------------------|-----------------------------------------------------------------------------|-------------------------------------------------------------------------------|------------------------------------------------------------------------|--------------------------------------------------------------|
| Three-phase systems | Single-phase systems with middle point | Equipment at the origin of the installation (impulse withstand category IV) | Equipment of distribution and final circuits (impulse withstand category III) | Appliances and current-using equipment (impulse withstand category II) | Specially protected equipment (impulse withstand category I) |
| – | 120-240 | 4 | 2,5 | 1,5 | 0,8 |
| 230/400 277/480 | – | 6 | 4 | 2,5 | 1,5 |
| 400/690 | – | 8 | 6 | 4 | 2,5 |
| 1 000 | – | 12 | 8 | 6 | 4 |
| ^a According to IEC 60038. | | | | | |
| ^b This impulse withstand voltage is applied between live conductors and PE. | | | | | |

3.45 maximum working peak output voltage

 \hat{U}_{out}

maximum repetitive occurring peak working voltage between the output terminals or between the output terminals and earth, during normal or abnormal operating condition and with transients neglected

3.46 ignition voltage

peak voltage applied to ignite a discharge lamp

3.46.1 ignition pulse voltage

peak ignition voltage with a total duration of $\leq 750 \mu\text{s}$ (summation of all pulses durations) within 10 ms, with the duration time (width) of each pulse being measured at the level of 50 % of the maximum absolute peak value

Note 1 to entry: Ignition pulse waveforms, which are considered as ignition pulse voltage, should not contain any dominant frequency above 30 kHz or should be usually highly damped (after 20 μs the peak voltage level should be less than one half of the maximum peak voltage). For the assessment of the dominant frequency IEC 60664-4:2005, Annex E should be consulted.

3.47 U_p equivalent transformed peak voltage

transformed output peak voltage, which is converted for the worst case peak voltage with its related frequency into an ignition pulse voltage

Note 1 to entry: The value of the declared equivalent transformed output peak voltage is the essential parameter for selecting the associated components

Note 2 to entry: See 3.46.1.

Note 3 to entry: To determine the declared equivalent transformed output peak voltage for basic insulation U_p [basic] the worst case combination of the maximum occurring peak voltage and frequency has to be taken into account, which means the maximum clearance according Table 10 for basic insulation.

Note 4 to entry: To determine the declared equivalent transformed output peak voltage for the reinforced insulation U_p [reinforced] the worst case combination of the maximum occurring peak voltage and frequency has to be taken into account, which means the maximum clearance according Table 11 for reinforced insulation.

3.48

LV supply

circuits, wiring or part of them connected to the low voltage (LV) public distribution network

EXAMPLE: 230V distribution network.

Note 1 to entry: The voltage of these circuits correspond to the voltage band II of IEC 60449.

Note 2 to entry: SELV and FELV are not included in the definition given here for a LV supply.

Note 3 to entry: High voltage (HV) supply corresponding to band III of IEC 60449 is not included in the definition given here for a LV supply.

4 General requirements

Lamp controlgear shall be so designed and constructed that in normal use it operates without danger to the user or surroundings.

Compliance is checked by carrying out all the tests specified.

Requirements for insulation materials used for double or reinforced insulation of controlgear are specified in Annex N of this standard.

In addition, independent lamp controlgear shall comply with the requirements of IEC 60598-1, including marking requirements of that standard such as IP classification and mechanical stress. Built-in ballasts with double or reinforced insulation shall comply additionally with the requirements of Annex I.

Built-in electronic controlgear with double or reinforced insulation shall comply additionally with the requirements of Annex O.

Some built-in lamp controlgear do not have their own enclosure and are composed of printed circuit boards and electrical components thereon, and shall comply with the requirements of IEC 60598-1 when built into the luminaire. Integral lamp controlgear not having their own enclosure shall be treated as integral components of luminaires defined in Clause 0.5 in IEC 60598-1:2014 and shall be tested assembled in the luminaire.

It is recommended for the luminaire manufacturer to confer about the relevant test requirements with the controlgear manufacturer, if necessary.

In the lamp safety standards, "Information for ballast design" is given for the safe operation of lamps. This shall be regarded as normative when testing ballasts.

Controlgears providing SELV shall comply with the additional requirements given in Annex L. This includes especially insulation resistance, electric strength, creepage distances and clearances between the primary and secondary circuit.

5 General notes on tests

5.1 Tests according to this standard are type tests.

The requirements and tolerances permitted by this standard are related to testing of a type test sample submitted by the manufacturer for that purpose. Compliance of the type test sample does not ensure compliance of the whole production of a manufacturer with this safety standard.

Conformity of production is the responsibility of the manufacturer and may include routine tests and quality assurance in addition to type testing.

5.2 Unless otherwise specified, the tests are carried out at an ambient temperature of 10 °C to 30 °C.

5.3 Unless otherwise specified, the type test is carried out on one sample consisting of one or more items submitted for the purpose of the type test.

In general, all tests are carried out on each type of lamp controlgear or, where a range of similar lamp controlgear is involved, for each wattage in the range or on a representative selection from the range, as agreed with the manufacturer.

Certain countries require that three samples of lamp controlgear be tested and, in such cases, if more than one sample fails, then the type is rejected. If one sample fails, the test is repeated using three other samples and all of these shall comply with the test requirements.

If the tests of 14.3 or 15.5 of IEC 61558-1:2005 have to be made, three additional samples are needed. These samples are used only for the test of 14.3 or 15.5 of IEC 61558-1:2005, respectively.

5.4 The tests shall be carried out in the order listed in this standard unless otherwise specified in Parts 2 of IEC 61347.

5.5 For the thermal test, independent lamp controlgear shall be mounted in a test corner consisting of three dull-black painted wooden/wood fibre boards 15 mm to 20 mm thick and arranged so as to resemble two walls and the ceiling of a room. The lamp controlgear is secured to the ceiling as close as possible to the walls, the ceiling extending at least 250 mm beyond the other side of the lamp controlgear.

5.6 For d.c. supplied ballasts intended for use from a battery supply it is permissible to substitute a d.c. power source other than a battery, provided that the source impedance is equivalent to that of a battery.

NOTE A non-inductive capacitor of appropriate rated voltage and with a capacitance of at least 50 µF, connected across the supply terminals of the unit under test, normally provides a source impedance simulating that of a battery.

5.7 When testing lamp controlgear to the requirements of this standard, earlier test reports may be updated in accordance with this edition by submitting a new sample for test together with the previous test report.

Full type testing may not generally be necessary and the product and the previous test results shall only be reviewed against any amended clause marked "R" as scheduled in Annex J.

5.8 Where the terms "voltage" and "current" are used, they imply the r.m.s. values unless otherwise stated.

6 Classification

Lamp controlgear is classified, according to the method of installation, as

- built-in;
- independent;
- integral.

7 Marking

7.1 Items to be marked

The parts that make up IEC 61347-2 state which of the following items shall be marked as mandatory markings or provided as information to be given either on the lamp controlgear or made available in the manufacturer's catalogue or similar.

For controlgear without an enclosure, and classified as built-in (e.g. open printed circuit board assembly), only items a) and b) are to be considered mandatory for marking on the controlgear. Other mandatory markings required by the IEC 61347-2 part shall be provided as information to be given either on the controlgear or made available in the manufacturer's catalogue or similar.

- a) Mark of origin (trade mark, manufacturer's name or name of the responsible vendor/supplier).
- b) Model number or type reference of the manufacturer.

- c) Symbol for independent lamp controlgear  [SOURCE: 60417-5138 (2002-10)] if applicable.
- d) The correlation between replaceable and interchangeable parts, including fuses, of lamp controlgear shall be marked unambiguously by legends on the lamp controlgear or, with the exception of fuses, be specified in the manufacturer's catalogue.
- e) Rated supply voltage (or voltages, if there are several), voltage range, supply frequency and supply current(s); the supply current may be given in the manufacturer's literature.
- f) The earthing terminals (if any) shall be identified by the symbol



[SOURCE: 60417-5019 (2006-08)] or



[SOURCE: 60417-5018 (2011-07)]

These symbols shall not be placed on screws or other easily removable parts.

If the lamp control gear is marked with an earthing symbol, the manufacturer's instruction shall contain the information whether it is permitted to use the control gear also without connection to earth.

For the use of symbols, see IEC 60417.

- g) The claimed value of the rated maximum operating temperature of the winding following the symbol t_w , values increasing in multiples of 5 °C.
- h) Indication that the lamp controlgear relies upon the luminaire enclosure for protection against accidental contact with live parts.
- i) Indication of the cross-section of conductors for which the terminals, if any, are suitable.
Symbol: relevant value(s) in square millimetres (mm²) followed by a small square.
- j) The lamp type and rated wattage or wattage range for which the lamp controlgear is suitable, or the designation as indicated on the lamp data sheet of the type(s) of lamp(s) for which the lamp controlgear is designed. If the lamp controlgear is intended to be used with more than one lamp, the number and rated wattages of each lamp shall be indicated.

NOTE 1 For lamp controlgear specified in IEC 61347-2-2, it is assumed that a marked wattage range includes all ratings within the range unless otherwise indicated in the manufacturer's literature.

- k) Wiring diagram indicating the position and purpose of terminals. In the case of lamp controlgear having no terminals, a clear indication shall be given on the wiring diagram of the significance of the code used for connecting wires. Lamp controlgear that operates in specific circuits only shall be identified accordingly, for example by marking or wiring diagram.

For controllable controlgear, control terminals shall be identified in the manufacturer catalogue or similar. The classification of insulation that has been maintained between live parts and control circuits shall be provided. E.g. basic insulation, reinforced insulation.

Maintenance of the declared insulation barrier may also be dependent on other external components/products connected to the same control bus. This is the responsibility of the control system designer, not the controlgear manufacturer.

l) Value of t_c .

If this relates to a certain place on the lamp controlgear, this place shall be indicated or shall be specified in the manufacturer's catalogue.

m) Symbol for temperature declared, thermally protected controlgear  (see Annex B). The dots in the triangle shall be replaced by the value of the rated maximum case temperature in degrees Celsius assigned by the manufacturer, values increasing in multiples of 10.

n) Heat sink(s) required additional to the lamp controlgear.

o) The limiting temperature of the winding under abnormal conditions which shall be respected when the controlgear is built into a luminaire, as information for luminaire design.

In the case of lamp controlgear intended for circuits which do not produce abnormal conditions, or are for use only with starting devices which exempt the lamp controlgear from the abnormal conditions of Annex C of IEC 60598-1:2014, the winding temperature under abnormal conditions is not indicated.

p) The test period for the endurance test for lamp controlgear which, at the manufacturer's choice, shall be tested for a period longer than 30 days, may be indicated with the symbol D, followed by the appropriate number of days, 60, 90 or 120 in 10-day periods, the whole being placed between the brackets immediately after the t_w indication. For example, (D6) for controlgear to be tested for a period of 60 days.

NOTE 2 The standard endurance test period of 30 days need not be indicated.

q) For lamp controlgear for which a constant S other than 4 500 is claimed by the manufacturer, the symbol S together with its appropriate value in thousands, for example "S6", if S has a value of 6 000.

Preferred values of S are: 4 500, 5 000, 6 000, 8 000, 11 000, 16 000.

r) The rated no-load output voltage, when it is higher than the supply voltage.

s) Symbol indicating the kind of controlgear providing SELV.

t) The earthing terminals of an independent controlgear used for the connection of lamp compartments (if any) shall be marked with the symbol:



[SOURCE: IEC 60417-6296 (2014-09)]

This symbol shall not be placed on screws or other easily removable parts. The symbol size of the earthing terminals of an independent controlgear used for the connection of lamp compartments shall be at least 5 mm (over all, including letters).

u) Declaration of the maximum working voltage U_{out} (r.m.s.) between

- output terminals, or
- any output terminal and earth (if applicable)
- in steps as described in Table 2.

Table 2 – Working voltage and U_{out} steps

| Working voltage | < 50 V | < 500 V | > 500 V |
|-----------------------|--------|---------|---------|
| U_{out} in steps of | 1 V | 10 V | 50 V |

The highest of the specified voltage values shall be marked on the controlgear as "Output working voltage = ...V" or "U-OUT = ...V" or " U_{out} = ...V".

Item u) is not applicable to terminals with SELV-circuits as defined in IEC 61558-1.

v) Declaration of the maximum equivalent output peak voltage U_p between:

- output terminals;
- any output terminal and earth, if applicable.

At least the highest of the specified voltage values shall be declared, for basic and reinforced insulation (U_p [basic] = xx kV and U_p [reinforced] = xx kV)

The declaration of the maximum equivalent output peak voltage U_p is not applicable to terminals with SELV-circuits as defined in IEC 61558-1.

The declared equivalent transformed output peak voltages are only required for voltages greater than 0,5 kV.

NOTE 3 Explanation of the meaning of U_p is given in 3.47. Guidance and example for the calculation of this parameter is given in Annex Q.

w) If the creepage distance values of the Table 8 of this standard have to be used and creepage distance is greater than the related creepage distances of Table 7, the maximum output peak voltage \hat{U}_{out} and its corresponding frequency f_{Uout} between:

- output terminals;
 - any output terminal and earth, if applicable,
- shall be declared.

Item w) is not applicable to terminals with SELV-circuits as defined in IEC 61558-1.

7.2 Durability and legibility of marking

Marking shall be durable and legible.

Compliance is checked by inspection and by trying to remove the marking by rubbing lightly, for 15 s each time, with two pieces of cloth, one soaked with water and the other with petroleum spirit.

The marking shall be legible after the test.

The petroleum spirit used should consist of a solvent hexane with a content of aromatics of maximum 0,1 % volume percentage, a kauri-butanol value of 29, an initial boiling-point of approximately 65 °C, a dry-point of approximately 69 °C and a density of approximately 0,68 g/cm³.

8 Terminals

Screw terminals shall comply with Section 14 of IEC 60598-1:2014.

Screwless terminals shall comply with Section 15 of IEC 60598-1:2014.

9 Earthing

9.1 Provisions for protective earthing (Symbol: IEC 60417-5019 (2006-08))

Earthing terminals shall comply with the requirements of Clause 8. The electrical connection/clamping means shall be adequately locked against loosening, and it shall not be possible to loosen the electrical connection/clamping means by hand without the use of a tool. For screwless terminals, it shall not be possible to loosen the clamping means/electrical connection unintentionally.

All parts of an earthing terminal shall be such as to minimize the danger of electrolytic corrosion resulting from contact with the earth conductor or any other metal in contact with them.

The screw and the other parts of the earthing terminal shall be made of brass or other metal no less resistant to corrosion, or material with a non-rusting surface and at least one of the contact surfaces shall be bare metal.

Compliance is checked according to 7.2.3 of IEC 60598-1:2014.

9.2 Provisions for functional earthing (Symbol: IEC 60417-5018 (2011-07))

Functional earthing terminals shall comply with the requirements of Clause 8 and 9.1.

The functional earthing contact (potential) of a lamp controlgear shall be insulated from the live parts by double or reinforced insulation.

9.3 Lamp controlgear with conductors for protective earthing by tracks on printed circuit boards

If a printed circuit board track is used for earthing internally, in the independent, built-in or integral lamp controlgear, it shall withstand the following test.

A current from an a.c. source of 25 A is passed for 1 min between the earthing terminal or earthing contact via the track on the printed circuit board and each of the accessible metal parts in turn.

After the test and after cooling the controlgear to ambient temperature, the requirements of 7.2.3 of IEC 60598-1:2014 shall apply.

9.4 Earthing of built-in lamp controlgear

It is allowed to earth built-in lamp controlgear by means of fixing the controlgear to earthed metal of the luminaire.

For compliance, see 7.2 of IEC 60598-1:2014.

If a lamp controlgear has an earthing terminal, this terminal shall only be used for earthing the built-in lamp controlgear.

Earthing of the luminaire or other equipment via the built-in lamp controlgear is not allowed.

9.5 Earthing via independent controlgear

9.5.1 Earth connection to other equipment

Independent lamp controlgear may have earthing terminals that allow the onward earth connection to other equipment in the installation. For looping or through connection, the conductor shall have a minimum cross-section of 1,5 mm² and be of copper, or an equivalent conductive material shall be used.

Protective earthing wires within the luminaire shall be in line with 5.3.1.1 and Section 7 of IEC 60598-1:2014. For looping-through, a minimum cross section of 1,5 mm² is required.

Compliance is checked by inspection and measurement.

9.5.2 Earthing of the lamp compartments powered via the independent lamp controlgear

Independent lamp controlgear may have earthing terminals that allow the earthing of the lamp compartment, which are powered by this controlgear. In this case, the earth path between the input and output earth terminals of the controlgear shall withstand the following test.

A current from an a.c. source of 25 A is passed for 1 min between the earthing terminal or earthing contact (via the track on the printed circuit board, if used for protective earth) and each of the accessible metal parts in turn.

After the test and after cooling the control gear at ambient temperature, a current of at least 10 A, derived from the source with a no-load voltage not exceeding 12 V, shall be passed between the earthing terminal or earthing contact and each of the accessible metal parts in turn. The voltage drop between the earthing terminal or earthing contact and the accessible metal part shall be measured and the resistance shall be calculated from the current and the voltage drop. In no case shall the calculated resistance value exceed 0,5 Ω .

The output earthing terminals to the lamp compartment shall be marked as described in 7.1 t).

10 Protection against accidental contact with live parts

10.1 Lamp controlgear which do not rely upon the luminaire enclosure for protection against electric shock shall be sufficiently protected against accidental contact with live parts (see Annex A) when installed as in normal use.

Integral lamp controlgear, which relies upon the luminaire enclosure for protection, shall be tested according to its intended use.

Lacquer or enamel is not considered to be adequate protection or insulation for the purpose of this requirement.

Parts providing protection against accidental contact shall have adequate mechanical strength and shall not work loose in normal use. It shall not be possible to remove them without the use of a tool.

Compliance is checked by inspection and by a manual test, and with regard to protection against accidental contact, by means of the test finger as shown in Figure 1 of IEC 60529:1989 using an electrical indicator to show contact. This finger is applied in all possible positions, if necessary, with a force of 10 N.

It is recommended that a lamp be used for the indication of contact and that the voltage be not less than 40 V.

10.2 Lamp controlgear incorporating capacitors of total capacitance exceeding 0,5 μF shall be constructed so that the voltage at the lamp controlgear terminations does not exceed 50 V, 1 min after disconnection of the lamp controlgear from a source of supply at rated voltage.

10.3 For controlgears providing SELV, the accessible conductive parts shall be electrically separated from live parts by at least double or reinforced insulation. There shall be no connection between the output circuit and the body or the protective earthing circuit, if any. Moreover, the construction shall be such that there is no possibility of any connection between these circuits, either directly or indirectly, through other conductive parts, except by deliberate action (see 10.4).

SELV output circuits shall be electrically separated from earth by at least basic insulation.

The expression “circuits” also covers windings of internal transformers (HF and others) of the controlgear.

In controlgears providing ELV, conductive parts are regarded as live parts and shall be insulated accordingly.

Compliance is checked by inspection, relevant insulation tests and measurements. See also Annex L.

10.4 Controlgears providing SELV may have accessible conductive parts in the SELV circuit; if: the rated output voltage under load does not exceed 25 V r.m.s. or 60 V d.c. ripple free d.c. where the voltage exceeds 25 V r.m.s. or 60 V ripple free d.c., the touch current does not exceed:

- for a.c.: 0,7 mA (peak);
- for d.c.: 2,0 mA;
- the no-load output does not exceed 35 V peak or 60 V ripple free d.c.

NOTE The limits given are based on IEC 60364-4-41.

Compliance is checked by measuring the output voltage when steady conditions are established, the controlgear being connected to rated supply voltage and rated frequency. For the test under load, the controlgear is loaded with a resistance which would give rated output (current or wattage respectively) at rated output voltage. For controlgears with more than one supply voltage, the requirements are applicable for each of the rated supply voltages.

The touch current is checked by measurement in accordance with Annex G from IEC 60598-1:2014.

For controlgears providing SELV with rated output voltages or currents exceeding the values given above at least one of the conductive parts in the SELV circuit shall be insulated by insulation capable of withstanding a test voltage of 500 V r.m.s. for 1 min.

Accessible conductive parts separated by double or reinforced insulation, e.g. live parts and the body or primary and secondary circuits, may be bridged (conductive bridged) by resistors or Y2 capacitors provided they consists of at least two separate components of the same rated value (resistance or capacitance) and are rated for the total working voltage and whose impedance is unlikely to change significantly during the individual lifetime of the controlgear. In addition, accessible conductive parts separated by double or reinforced insulation from live parts, as above, may be bridged by a single Y1 capacitor.

Y1 or Y2 capacitors shall comply with relevant requirements of IEC 60384-14 and if resistors are used they shall comply with the requirements of test a) in 14.1 of IEC 60065:2001.

11 Moisture resistance and insulation

Lamp controlgear shall be moisture-resistant. They shall not show any appreciable damage after being subjected to the following test.

The lamp controlgear is placed in the most unfavourable position of normal use, in a humidity cabinet containing air with a relative humidity maintained between 91 % and 95 %. The temperature of the air at all places where samples can be located shall be maintained within 1 °C of any convenient value t between 20 °C and 30 °C.

Before being placed in the humidity cabinet, the sample is brought to a temperature between t and $(t + 4)$ °C. The sample shall be kept in the cabinet for 48 h.

In most cases, the sample may be brought to the specified temperature between t and $(t + 4)$ °C by keeping it in a room at this temperature for at least 4 h before the humidity treatment.

In order to achieve the specified conditions within this cabinet, it is necessary to ensure constant circulation of the air within, and, in general, to use a cabinet which is thermally insulated.

Insulation resistance shall be not less than 2 MΩ for basic insulation and 4 MΩ for double or reinforced insulation between live parts and the body. For insulation between primary and secondary circuits, in controlgear providing SELV, other values apply (see Annex L).

Insulation shall be adequate

- a) between live parts and outer metal parts, including fixing screws and metal foil in contact with outer insulating parts;
- b) between live parts and control terminals, where relevant.

In the case of lamp controlgear having an internal connection or component between one or more output terminals and the earth terminal, such a connection shall be removed during this test.

For the test the input and output terminals shall be bonded together. Controlgear, having insulation cover or envelope is wrapped with metal foil.

12 Electric strength

Lamp controlgear shall have adequate electric strength.

Immediately after the measurement of the insulation resistance, the lamp controlgear shall withstand an electric strength test for 1 min applied between the parts specified in Clause 11.

The test voltage of substantially sine-wave form, having a frequency of 50 Hz or 60 Hz shall correspond to the values in Table 3. Initially, not more than half the specified voltage shall be applied, the voltage then being raised rapidly to the prescribed value.

Table 3 – Electric strength test voltage

| Working voltage U | | Test voltage V |
|----------------------------------------------------------------------------------------------------------------------------------------------------------------------------------------------------------------------------|---------------------------------|-------------------|
| Basic insulation for voltages of SELV | | 500 |
| Up to and including 50 V | | 500 |
| Above 50 V up to and including 1 000 V | Basic insulation | $2 U + 1\,000$ |
| | Supplementary insulation | $2 U + 1\,000$ |
| | Double or reinforced insulation | $4 U + 2\,000$ |
| Where both reinforced insulation and double insulation are used, care shall be taken that the voltage applied to the reinforced insulation does not overstress the basic insulation or the supplementary insulation. | | |
| When testing the controlgear, the input should be tested with a test voltage which corresponds with the supply voltage and the output related part should be tested with a test voltage which corresponds with U_{out} . | | |

For solid or thin sheet insulation used for double or reinforced insulation Annex N applies.

No flashover or breakdown shall occur during the test.

The high-voltage transformer used for the test shall be so designed that when the output terminals are short-circuited after the output voltage has been adjusted to the appropriate test voltage, the output current is at least 200 mA.

The overcurrent relay shall not trip when the output current is less than 100 mA.

The r.m.s. value of the test voltage applied shall be measured to within $\pm 3\%$.

The metal foil referred to in Clause 11 shall be placed so that no flashover occurs at the edges of the insulation.

Glow discharges without drop in voltage are neglected.

13 Thermal endurance test for windings of ballasts

Windings of ballasts shall have adequate thermal endurance.

Compliance is checked by the following test.

For windings included in controlgears providing SELV, see modifications specified in IEC 61558-1:2005, Annex U.

The purpose of this test is to check the validity of the rated maximum operating temperature (t_w) marked on the ballast. The test is carried out on seven new ballasts which have not been subjected to the preceding tests. They shall not be used for further testing.

This test may also be applied to ballasts which form an integral part of a luminaire and which cannot be tested separately, thereby enabling such integral ballasts to be made with a t_w value.

Before the test, each ballast shall start and operate a lamp normally, and the lamp arc current shall be measured under normal conditions of operation and at a rated voltage. Details of the thermal endurance test are prescribed below. The thermal conditions shall be so adjusted that the objective duration of the test is as indicated by the manufacturer. If no indication is given, the test period shall be 30 days.

The test is carried out in an appropriate oven.

The ballast shall function electrically in a manner similar to that in normal use, and, in the case of capacitors, components or other auxiliaries not subjected to the test, these shall be disconnected and reconnected again in the circuit but outside the oven. Other components which do not influence the operating conditions of the windings may be removed.

Where it is necessary to disconnect capacitors, components or other auxiliaries, it is recommended that the manufacturer supplies special ballasts with these parts removed and any necessary additional connections brought out from the ballast.

In general, to obtain normal operating conditions, the ballast is tested with the appropriate lamp.

The ballast container, if of metal, is earthed. Lamps are always kept outside the oven.

For certain inductive ballasts of simple impedance (for example, switch-start choke ballasts), the test is made without a lamp or resistor, provided the current is adjusted to the same value as found with the lamp at rated supply voltage.

The ballast is connected to the power supply so that the voltage stress between the lamp controlgear winding and earth is similar to the one in the lamp method.

Seven ballasts are placed in the oven, and the rated supply voltage applied to each of the circuits.

The oven thermostats are then regulated so that the internal temperature of the oven attains a value such that the temperature of the hottest winding in each of the ballasts is approximately equal to the theoretical value given in Table 4.

For ballasts subject to a test duration longer than 30 days, the theoretical test temperatures shall be calculated by means of Equation (2).

After 4 h, the actual temperature of the winding is determined by the "change-in-resistance" method, and, if necessary, the oven thermostats are readjusted to approximate as closely as possible the desired test temperature. Thereafter, a daily reading of the air temperature in the oven is taken to ensure that the thermostats are maintained at the correct value to within ± 2 °C.

The winding temperatures are measured again after 24 h and the final test period for each lamp controlgear is determined from Equation (2). Figure 1 illustrates this in graphical form. The permissible difference between the actual temperature of the hottest winding of any of the ballasts under test and the theoretical value shall be such that the final test period is at least equal to, but not more than twice, the foreseen test period.

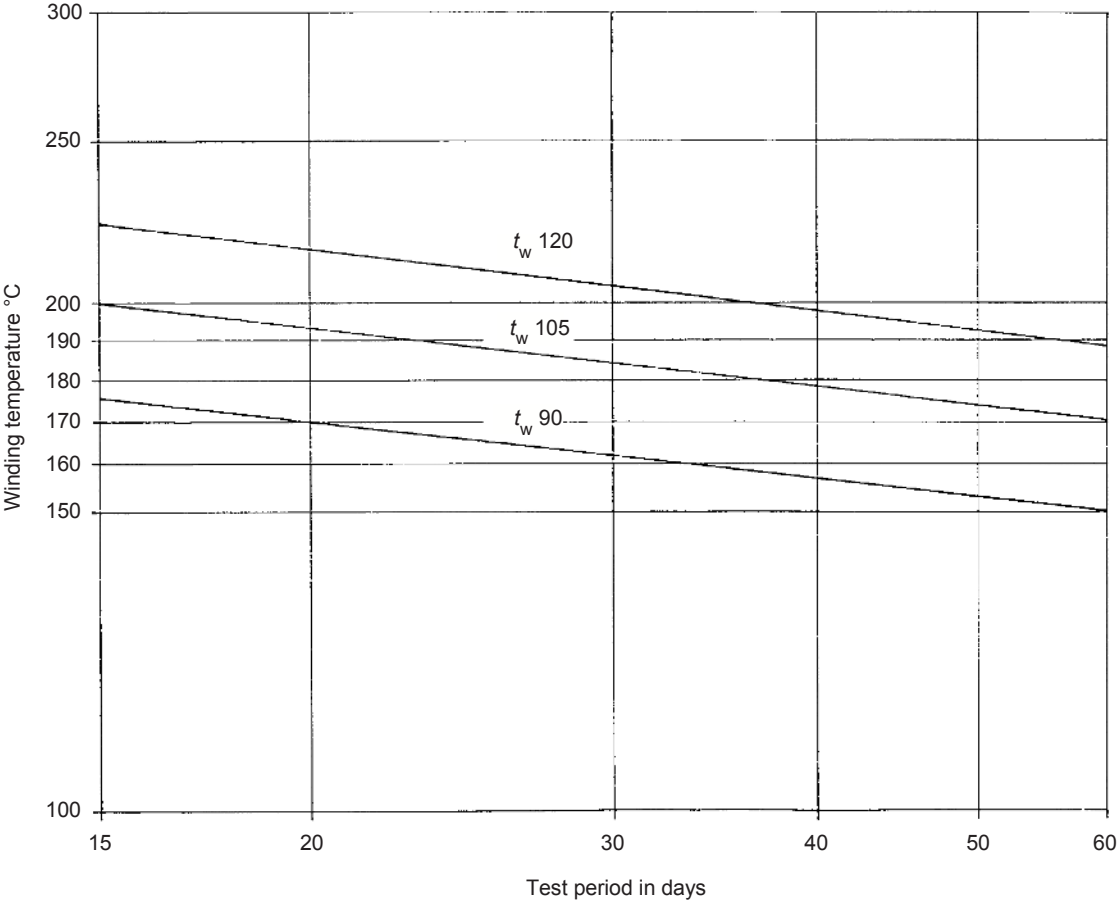

IEC

NOTE These curves are for information only and illustrate Equation (2) using a constant S of 4 500 (see Annex E).

Figure 1 – Relation between winding temperature and endurance test duration

Table 4 – Theoretical test temperatures for ballasts subjected to an endurance test duration of 30 days

| Constant S | Theoretical test temperature °C | | | | | |
|-------------|------------------------------------|-----|-----|-----|-----|-----|
| | S4,5 | S5 | S6 | S8 | S11 | S16 |
| For $t_w =$ | | | | | | |
| 90 | 163 | 155 | 142 | 128 | 117 | 108 |
| 95 | 171 | 162 | 149 | 134 | 123 | 113 |
| 100 | 178 | 169 | 156 | 140 | 128 | 119 |
| 105 | 185 | 176 | 162 | 146 | 134 | 125 |
| 110 | 193 | 183 | 169 | 152 | 140 | 130 |
| 115 | 200 | 190 | 175 | 159 | 146 | 136 |
| 120 | 207 | 197 | 182 | 165 | 152 | 141 |
| 125 | 215 | 204 | 189 | 171 | 157 | 147 |
| 130 | 222 | 211 | 196 | 177 | 163 | 152 |
| 135 | 230 | 219 | 202 | 184 | 169 | 158 |
| 140 | 238 | 226 | 209 | 190 | 175 | 163 |
| 145 | 245 | 233 | 216 | 196 | 181 | 169 |
| 150 | 253 | 241 | 223 | 202 | 187 | 175 |

Unless otherwise indicated on the ballast, the theoretical test temperatures specified in column S4,5 apply. The use of a constant other than S4,5 shall be justified in accordance with Annex E.

For the measurement of winding temperature by the "change-in-resistance" method, the following Equation (1) is applicable:

$$t_2 = \frac{R_2}{R_1} (234,5 + t_1) - 234,5 \quad (1)$$

where

t_1 is the initial temperature in degrees Celsius;

t_2 is the final temperature in degrees Celsius;

R_1 is the resistance at temperature t_1 ;

R_2 is the resistance at temperature t_2 .

The constant 234,5 relates to copper windings; for aluminium, this constant should be 229.

No attempt shall be made to hold the winding temperature constant after the measurement taken after 24 h. Only the ambient air temperature shall be stabilized by the thermostatic control.

The test period for each ballast starts from the time the ballast is connected to the supply. At the end of its test, the relevant ballast is disconnected from the supply but is not removed from the oven until the tests on the other ballast have been completed.

The theoretical test temperatures given in Figure 1 correspond to a working life of 10 years' continuous operation at the rated maximum operating temperature t_w .

They are computed using the following equation:

$$\log L = \log L_o + S \left(\frac{1}{T} - \frac{1}{T_w} \right) \quad (2)$$

where

L is the objective endurance test life in days (30, 60, 90 or 120);

L_o equals 3 652 days (10 years);

T is the theoretical test temperature in kelvins ($t + 273$);

T_w is the rated maximum operating temperature in kelvins ($t_w + 273$);

S is the constant depending on the design of the lamp controlgear and the winding insulation used.

After the test, when the ballasts have returned to room temperature, they shall satisfy the following requirements.

a) At rated voltage, the ballast shall start the same lamp and the lamp arc current shall not exceed 115 % of the value measured before the test, as described above.

This test is to determine any adverse change in the ballast setting.

b) The insulation resistance between the winding and the ballast case, measured at approximately 500 V d.c. shall be not less than 1 M Ω .

The result of the test is considered to be satisfactory if at least six of the seven ballasts satisfy these requirements. The test is considered to have failed if more than two ballasts fail the test.

In the case of two failures, the test is repeated with seven more ballasts and no failure of these is permitted.

14 Fault conditions

14.1 Lamp controlgear shall be so designed that, when operated under fault conditions, there shall be no emission of flames or molten material or production of flammable gases. The protection against accidental contact in accordance with 10.1 shall not be impaired.

Operation under fault conditions denotes that each of the conditions specified in 14.2 to 14.5 is applied in turn and, associated with it, those other fault conditions which are a logical consequence thereof, with the provision that only one component at a time should be subjected to a fault condition.

If a lamp controlgear marked with a protective earthing symbol and the manufacturer declared in the instructions that the use of the controlgear without earthing contact is permitted then the operation under fault conditions shall be made with and without earthing connection.

If a lamp controlgear marked with a functional earthing symbol and the manufacturer declared in the instructions that the use of the controlgear without functional earthing contact is permitted then the operation under fault conditions shall be made with and without earthing connection.

Examination of the apparatus and its circuit diagram will generally show the fault conditions which should be applied. These are applied in sequence in the order which is most convenient.

The intention of Clause 14 is to check if the controlgear remains safe if a single fault occurs in the controlgear. To that extent each component shall be short-circuited or opened and PCB tracks closer together than required according to Clause 16 of this standard shall be short-circuited. The requirement is that the controlgear shall not cause harm to persons or goods. Safety components which comply with their own safety standard are excluded if they are used within their specifications.

With this test, evidence will be given that the controlgear will be safe under any single fault condition.

Filter capacitors directly connected to the mains supply do not need to be tested if they comply with IEC 60384-14 and are classified X1 or X2 for the relevant voltage.

The manufacturer shall show evidence that the components behave in the foreseen way, for example by showing compliance with the relevant specification.

Capacitors, resistors or inductors not complying with a relevant standard shall be short-circuited or disconnected, whichever is the more unfavourable.

For lamp controlgear marked with , the lamp controlgear case temperature at any place shall not exceed the marked value.

Lamp controlgear and filter coils without these symbols are checked together with the luminaire in accordance with IEC 60598-1.

14.2 Short circuit across creepage distances and clearances, if less than the values specified in Clause 16, taking into account any reduction allowed in 14.2 to 14.5.

Creepage and clearance distances below the values of Clause 16 are not allowed between live parts and accessible metal parts and between different circuits. This requirement is also applicable between tracks of printed circuit board.

Between conductors protected from surge energy from the supply (for example, by choke winding or capacitor) which are on a printed board complying with the pull-off and peel strength requirements specified in IEC 61189-2, the creepage distance requirements are modified according to Table 5 with a minimum of 0,5 mm.

Table 5 – Minimum creepage distance on printed circuit board

| Voltage (rms) V | Creepage distance mm |
|-----------------------|-------------------------|
| 50 | 0,5 |
| 100 | 0,5 |
| 160 | 0,5 |
| 200 | 0,63 |
| 250 | 1,0 |
| 320 | 1,6 |
| 400 | 2,0 |
| 500 | 2,5 |
| 630 | 3,2 |
| 800 | 4,0 |
| 1 000 | 5,0 |

NOTE 1 The values of this table have been taken from Table F.4 of IEC 60664-1:2007 – minimum creepage distances for printed wiring material – pollution degree 2 (all material groups except III b).

NOTE 2 Values for creepage distances can be found, for intermediate values of working voltages, by linear interpolation between tabulated values.

NOTE 3 For creepage distances, the equivalent d.c. voltage is equal to the r.m.s. value of the sinusoidal a.c. voltage.

14.3 Short circuit across or, if applicable, interruption of semi-conductor devices.

Only one component at a time shall be short-circuited (or interrupted).

14.4 Short circuit across insulation consisting of covering of lacquer, enamel or textile.

Such coverings are ignored in assessing the creepage distances specified in Table 7 and clearances specified in Table 9. However, if enamel forms the insulation of a wire and withstands the voltage test prescribed in Clause 13 of IEC 60317-0-1:2013, it is considered as contributing 1 mm to those creepage distances and clearances in air.

This subclause does not imply a need to short-circuit the insulation between turns of coils, insulating sleeves or tubing.

14.5 Short circuit across electrolytic capacitors.

14.6 Compliance with 14.2 to 14.5 shall be checked by operating the lamp controlgear at the rated supply voltage according to the test circuit procedure given in 14.7, with the lamp(s) connected and the lamp controlgear case at t_c . Each of the fault conditions outlined in 14.2 to 14.5 inclusive shall then be applied in turn.

For the purpose of this clause the test voltage may be at any value within the supply voltage range of the control gear, or within $\pm 5\%$ where only single rated supply voltage is given. This is to allow the high supply current capacity required for this test.

The tests shall be carried out on three samples for each fault condition, consisting of one or more items submitted for the purpose of the type test. If one of the samples fails, the test shall be repeated with three new samples none of which shall fail.

The test shall be continued until stable conditions are obtained. The lamp controlgear case temperature shall then be measured.

NOTE Components such as resistors, capacitors, semiconductors, fuses, etc. could fail. Such components can be replaced so as to continue the test.

Insulation shall be adequate between input and output terminals bonded together, and all exposed metal parts and the control terminals, where relevant. Controlgear, having insulation cover or envelope is wrapped with metal foil.

After the tests, when the lamp controlgear has returned to ambient temperature, the insulation resistance measured at approximately 500 V d.c. shall be not less than 1 M Ω .

To check whether gases liberated from component parts are flammable or not, a test with a high-frequency spark generator shall be made.

Accessible parts shall be tested in accordance with Annex A to determine whether they have become live.

To check whether emission of flames or molten material might present a safety hazard, the test specimen shall be wrapped with a tissue paper, as defined in 4.187 of ISO 4046-4:2002, and the latter shall not ignite.

14.7 Connect the controlgear under test to a high-power a.c. supply capable of passing a fault current of 160 A ${}_{+10}^{-0}$ % r.m.s., as shown in Figure 2. Apply the relevant fault condition.

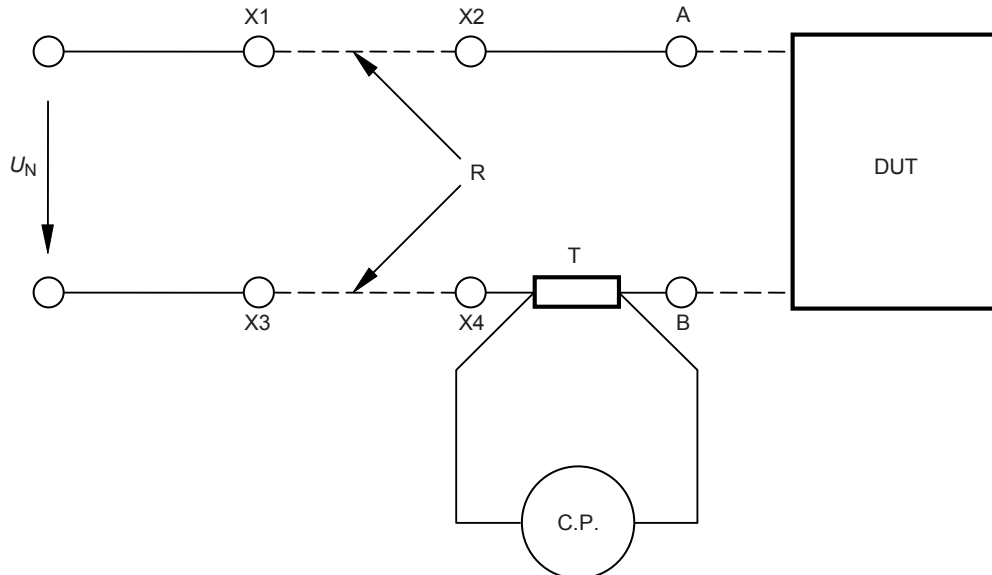

IEC

Key

| | |
|----------------|----------------------------------------------------------|
| U_N | supply voltage |
| DUT | device under test |
| R | additional wiring or resistor for current tuning |
| T | shunt 10 m Ω |
| X1, X2, X3, X4 | terminals for the additional wiring or resistor |
| A, B | terminals for the short circuit and the lamp controlgear |
| C.P. | current probe |

Figure 2 – Test circuit for controlgear

Carry out the test procedure as follows.

- a) Short circuit terminals A and B.

Test current calibration with additional wire or resistor between the terminals X1 – X2 and X3 – X4. Current value shall be $160 \text{ A} \begin{matrix} -0 \\ +10 \end{matrix} \% \text{ r.m.s.}$.

- b) Remove the short circuit.

Connect the controlgear to terminals A and B.

- c) Test the controlgear.

15 Construction

15.1 Wood, cotton, silk, paper and similar fibrous material

Wood, cotton, silk, paper and similar fibrous material shall not be used as insulation, unless impregnated.

Compliance is checked by inspection.

15.2 Printed circuits

Printed circuits are permitted for internal connections.

Compliance is checked by reference to Clause 14 of this standard.

15.3 Plugs and socket-outlets used in SELV or ELV circuits

For controlgears providing SELV or ELV socket-outlets, the output circuit shall be such that there is no dangerous compatibility between such a socket-outlet and a plug intended for direct connection to a socket-outlet which could be used for the input circuit in relation to installation rules, voltages and frequencies.

Plugs and socket-outlets for SELV system shall comply with the requirements of IEC 60906-3 and IEC 60884-2-4. However, plugs and socket-outlets for SELV systems with both a rated current $\sim 3 \text{ A}$ and a maximum voltage of 25 V a.c. or 60 V d.c. with a power not exceeding 72 W are allowed to comply only with the following requirements:

- plugs shall not be able to enter socket-outlets of other standardised systems;
- socket-outlets shall not admit plugs of other standardised voltage systems;
- socket-outlets shall not have a protective earth contact.

As IEC 60906-3 covers only 6 V , 12 V , 24 V and 48 V output voltage, controlgear with intermediate output voltages shall be able to withstand the nearest upper voltage.

15.4 Insulation between circuits and accessible parts

15.4.1 General

Controlgear shall provide suitable insulation between different electrical circuits and to accessible parts.

The same requirements apply to the circuits connected to the control interface of a controllable electronic controlgear where the control circuits shall be isolated from the LV supply according to the declaration of the controlgear manufacturer (see 7.1 k)).

No insulation is required where:

- control signals are injected via the supply terminals or circuits connected to the supply via a separate terminal;
- control signal receiver is located in the ballast case and the signal is transmitted remotely via infra-red or radio wave transmitters;
- control terminals are only to be used together with one sensing device outside of the controlgear case, but inside the luminaire (not remotely).

NOTE At present on the market the following types of control systems are available:

- FELV control signal, basic insulated to LV supply (e.g. Digital Addressable Lighting Interface and 0 to 10 V);
- SELV control signal, (e.g. DMX);
- control signal, not insulated to LV supply (e.g. Push button control/phase cut/step dim).

Compliance is checked by the following requirements.

15.4.2 SELV circuits

The following sources may be used to supply SELV circuits:

- a safety isolating transformer in accordance with IEC 61558-2-6 or equivalent Part 2 of IEC 61558;
- a controlgear providing SELV in accordance with IEC 61347-2-2, IEC 61347-2-3, IEC 61347-2-7, IEC 61347-2-13;
- an electrochemical source (e.g. a battery) or another source independent of a higher voltage circuit.

The voltage in the circuits shall not be higher than the limits defined for ELV.

SELV circuits shall be insulated from the LV supply by double or reinforced insulation (based upon a working voltage across the insulation).

SELV circuits shall be insulated from other non SELV circuits (except FELV) by double or reinforced insulation (based upon a working voltage equal to highest voltage in the circuits).

SELV circuits shall be insulated from FELV circuits by supplementary insulation (based upon a working voltage equal to LV supply voltage).

SELV circuits shall be insulated from other SELV circuits by basic insulation (based upon a working voltage equal to highest voltage in the circuits).

SELV circuits shall be insulated from accessible conductive parts by insulation according to Table 6 in 15.4.5.

In cases of a controlgear providing SELV according to this standard, the SELV voltage shall be considered for insulating purpose as the maximum output voltage indicated as " U_{OUT} ".

Compliance is checked by inspection and by the tests required in Clause 10, 11, 12 and 16 of this standard.

15.4.3 FELV circuits

The following sources may be used to supply FELV circuits:

- a separating transformer in accordance with IEC 61558-2-1 or equivalent Part 2 of IEC 61558;
- a separating controlgear providing basic insulation between input and output circuits in accordance with the relevant Part 2 of this standard;

- an electrochemical source (e.g. a battery) or another source in circuit separated by the LV supply by basic insulation only.

The voltage in the circuits shall not be higher than the limits defined for ELV.

FELV circuits shall be insulated from the LV supply by at least basic insulation (based upon a working voltage equal to LV supply voltage).

It is not required that FELV circuits shall be insulated from other FELV circuits except for functional purpose.

FELV circuits shall be insulated from accessible conductive parts by an insulation according to Table 6 in 15.4.5.

Compliance is checked by inspection and by the tests required in Clause 10, 11, 12 and 16 of this standard.

Plugs and socket-outlets for FELV systems shall comply with the following requirements:

- plugs shall not be able to enter socket-outlets of other voltage systems;
- socket-outlets shall not admit plugs of other voltage systems;
- socket-outlets shall have a protective conductor contact.

Compliance is checked by inspection.

15.4.4 Other circuits

The insulation between circuits other than SELV or FELV and accessible conductive parts shall be in accordance with the requirements in Table 6 of 15.4.5.

Compliance is checked by applying the requirements of this standard to the insulation required in 15.4.5.

NOTE Example of this kind of circuits are:

- output circuits of ballast;
- circuits supplied by isolating transformer according to IEC 61558-2-4 or equivalent;
- circuits supplied by separating transformers according to IEC 61558-2-1 which do not fulfil the requirements for FELV;
- circuits supplied by separating controlgear (other than FELV) and isolating controlgear according with IEC 61347-2-2, IEC 61347-2-3, IEC 61347-2-7, IEC 61347-2-13.

15.4.5 Insulation between circuits and accessible conductive parts

Accessible conductive parts shall be insulated from active parts of electric circuit by an insulation according to Table 6. Figure 3 gives an example of a controlgear insulation related to explanation in Table 6.

In class II construction, where equipotential bonding is used for the protection against indirect contacts with live parts, the following requirements are applicable.

- All conductive parts are connected together so that two failures of the insulation result in a short circuit.
- To check whether the conductive parts are reliably connected together, the test of IEC 60598-1:2014, 7.2.3 (earth continuity test with 10 A) has to be carried out.
- The conductive parts comply with the requirements of Annex A of this standard in case of insulation fault between live parts and accessible conductive parts.

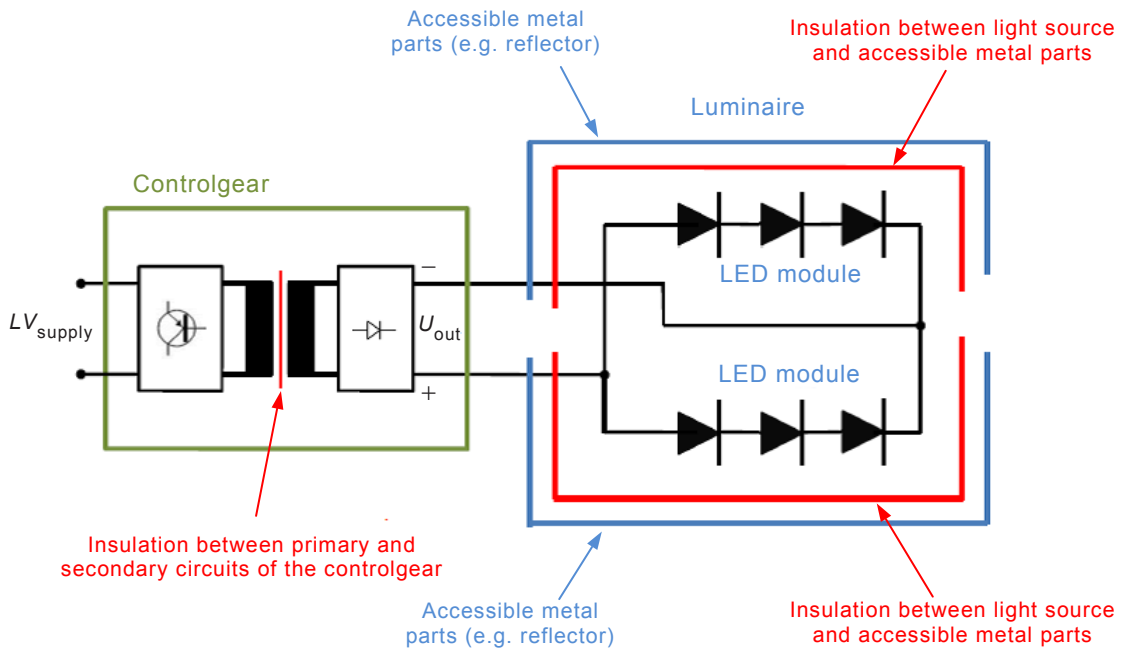





Figure 3 – Example of a controlgear insulation related to Table 6

Table 6 – Insulation requirements between active parts and accessible conductive parts

| Controlgear | | Required Insulation between active parts and accessible conductive parts | | | |
|-----------------------------------------------------------------------------------------------------------------------|-----------------------------|--------------------------------------------------------------------------|------------------------------------------------------------------------------------------|------------------------------------------------------------------------------------------|---------------------------------------------------------------------------------------------------------------------------------------------------------------------------------------------------------|
| | | Class I | Class II | Class II | |
| Insulation between LV supply and secondary circuits | | Insulation of accessible earthed conductive parts | Insulation of one accessible conductive part or more than one with equipotential bonding | Insulation of more than one accessible conductive parts without equipotential bonding | |
|  [SOURCE: 60417-5941 (2002-10)] | none | $U_{out} > LV_{supply}$ | Basic insulation complying with U_{out} | Double or reinforced insulation complying with U_{out} | Double or reinforced insulation complying with U_{out} |
| | | $U_{out} \leq LV_{supply}$ | Basic insulation complying with LV_{supply} | Double or reinforced insulation complying with LV_{supply} | Double or reinforced insulation complying with LV_{supply} |
|  [SOURCE: 60417-5156 (2003-08)] | basic | Voltages above ELV (FELV) | Basic insulation complying with U_{out} | Supplementary insulation complying with U_{out} plus LV_{supply} | Insulation has to fulfil the higher requirement of a) or b): a) Supplementary insulation complying with U_{out} plus $LV_{primary}$ b) Double or reinforced insulation complying with U_{out} |
| | | ELV (FELV) | Functional insulation | Supplementary insulation complying with U_{out} plus LV_{supply} | Supplementary insulation complying with U_{out} plus LV_{supply} |
|  [SOURCE: 60417-5221 (2002-10)] | double or reinforced | Voltages above ELV (FELV) | Basic insulation complying with U_{out} | Basic insulation complying with U_{out} | Double or reinforced insulation complying with U_{out} |
|  [SOURCE: 60417-5222 (2002-10)] | | ELV (SELV) | Basic insulation See also requirements in IEC 60598-1:2014, Sections 8, 10 and 11 | Basic insulation See also requirements in IEC 60598-1:2014, Sections 8, 10 and 11 | Basic insulation See also requirements in IEC 60598-1:2014, Sections 8, 10 and 11 |

16 Creepage distances and clearances

16.1 General

This clause specifies minimum requirements for creepage distances (see 16.2) and clearances (see 16.3) for lamp controlgear. Exemptions are only specified in Clause 14. Additional requirements for SELV are given in Annex L.

The requirements for creepage distances and clearances have to be applied:

for basic insulation:

- between live parts of different polarity;
- between live parts and accessible earthed metal parts;
- between circuits requiring isolation from each other (e.g. FELV circuits);
- between accessible conductive parts and a metal rod of the same diameter as the flexible cable or cord (or a metal foil wrapped around the cord) inserted inside inlet bushing, anchorage and the like;
- between live part and an intermediate conductive part;
- between an intermediate conductive part and the body;

for double or reinforced insulation:

- for lamp controlgear declared not to rely on the luminaire enclosure for protection against electric shock – between live parts and the outer accessible surface of insulating parts;
- between live parts and accessible unearthed metal parts;
- between circuits requiring isolation from each other (e.g. SELV circuits).

A metal enclosure shall have an insulating lining in accordance with IEC 60598-1 if, in the absence of such a lining, the creepage distance or clearance between the live parts and the enclosure would be smaller than the value prescribed in the relevant tables.

Reductions for creepage distances and clearances are allowed for lamp controlgear which are protected against pollution by the use of coating or potting. In this case pollution degree 1 applies.

The minimum dimensions and verification tests are given in Annex P.

Creepage distances and clearances shall be measured on uncoated products.

Distances which provide basic insulation for the same circuit between live parts of different polarities on printed circuit boards are exempt from the requirements of this subclause, because they are tested according to Clause 14.

Values for creepage distances and clearance given in this subclause are the absolute minimum. Exemptions for PCB are given in Clause 14.

NOTE 1 The minimum creepage distances and clearances specified are based on the following parameters:

- for use with up to 2 000 m above sea level;
- pollution degree 2 where normally only non-conductive pollution occurs but occasionally a temporary conductivity caused by condensation is to be expected;
- equipment of impulse withstand category II which is energy-consuming equipment to be supplied from the fixed installation.

NOTE 2 The way in which creepage distances and clearances are measured is specified in IEC 60664-1.

NOTE 3 The calculation method and the structure of the creepage distances and clearances are taken from IEC 60664-1:2007 and IEC 60664-4:2005.

For details of pollution degrees or impulse withstand categories, IEC 60664-1 should be consulted.

NOTE 4 Under Annex M of this standard, information about values for impulse withstand category III are presented.

NOTE 5 Creepage distances are distances in air, measured along the external surface of the insulation material.

NOTE 6 Creepage distances between ballast windings are not measured because they are checked with the endurance test. This applies also to creepage distances between taps.

NOTE 7 In open-core ballast, enamel, or similar material, which forms the insulation for a wire and withstands the voltage test for Grade 1 or 2 of IEC 60317-0-1:2013 (Clause 13) is judged to contribute 1 mm to the values given in Tables 7 and 8 of this standard between enamelled wires of different windings or from enamelled wire to covers, iron cores, etc.

However, this applies only in the situation where creepage distances and clearances are not less than 2 mm in addition to the enamelled layers.

16.2 Creepage distances

16.2.1 General

The minimum values for creepage distances are listed in Tables 7 and 8.

For the dimensioning of the creepage distances the r.m.s. values of the working voltage (Table 7) shall be taken into account.

For working voltages with higher operating frequencies than 30 kHz, additionally the peak values of the working voltages (Table 8) shall be taken into account. For such kind of working voltages (with frequencies above 30 kHz) both Tables 7 and 8 shall be applied.

The working voltage used for specifying the r.m.s. is determined by averaging over a time period of 60 s, unless the manufacturer specifies a shorter time period.

Guidance for the use of the Tables 7 and 8 is given in Figure 4.

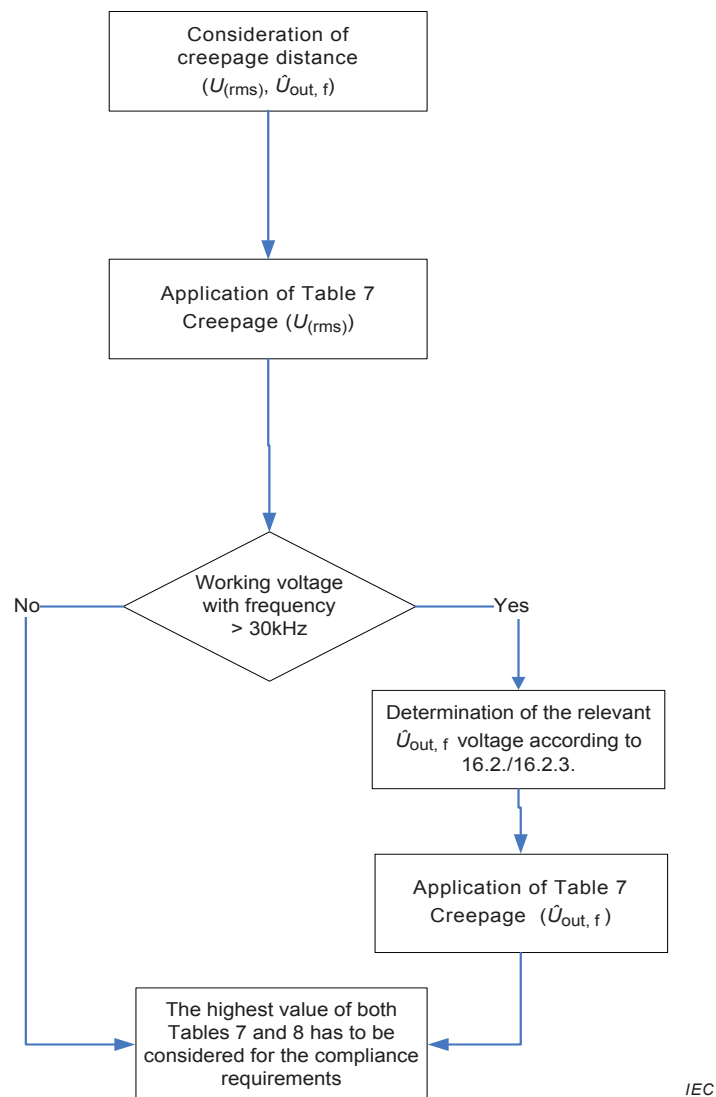

Figure 4 – Application of Table 7 and Table 8

Values for creepage distances may be found for intermediate values of working and working voltages by linear interpolation between tabulated values.

Creepage distances shall not be less than the required minimum clearance.

No values are specified for working voltages below 25 V a.c. and 60 V ripple free d.c. The test voltages for such working voltages are given in Clause 12, Table 1.

16.2.2 Minimum creepage distances for working voltages

Table 7 defines the minimum creepage distance values for working voltages.

Table 7 – Minimum creepage distances for working voltage

| Distances mm | RMS working voltage not exceeding V | | | | | |
|------------------------------------------------------------------------------------------------------------------------------|-------------------------------------------|-----|-----|-----|-----|-------|
| | 50 | 150 | 250 | 500 | 750 | 1 000 |
| Creepage distances ^a | | | | | | |
| – Basic or supplementary insulation PTI ^b ≥ 600 | 0,6 | 0,8 | 1,3 | 2,5 | 3,8 | 5,0 |
| – Basic or supplementary insulation PTI ^b < 600 | 1,2 | 1,6 | 2,5 | 5,0 | 7,6 | 10 |
| – Reinforced insulation PTI ^b ≥ 600 | – | 1,6 | 2,6 | 5,0 | 7,6 | 10 |
| – Reinforced insulation PTI ^b < 600 | – | 3,2 | 5,0 | 10 | 16 | 20 |
| Linear interpolation between columns is allowed. | | | | | | |
| NOTE In Japan and North America, the values defined here are not applicable. Japan and North America require larger values. | | | | | | |
| ^a For creepage distances the equivalent d.c. voltage is equal to the r.m.s. value of the sinusoidal a.c. voltage. | | | | | | |
| ^b PTI (proof tracking index) in accordance with IEC 60112. | | | | | | |

In the case of creepage distances to parts not energized, or not intended to be earthed, where tracking cannot occur, the values specified for material with PTI ≥ 600 shall apply for all materials (in spite of the real PTI).

For creepage distances subjected to working voltages with duration less than 60 s, the values specified for materials with PTI ≥ 600 shall apply for all materials.

For creepage distances not liable to contamination by dust or moisture, the values specified for materials with PTI ≥ 600 apply (regardless of the real PTI).

16.2.3 Creepage distances for working voltages with frequencies above 30 kHz

Table 8 presents creepage distance values for working voltages with frequencies above 30 kHz for all insulation materials (except for glass, ceramic or other inorganic materials, which do not track) – there is no distinction into different PTI classes.

For working voltages with frequencies above 30 kHz the peak value of the voltage shall be considered, because partial discharges damage the surfaces and may cause tracking.

The peak value of the working voltage excludes small peaks or transients like ignition voltages, unless these peaks increase the declared r.m.s. value of the working voltage (U_{out}) by 10 % or more. The verification has to be done for the worst case condition.

Table 8 – Minimum value of creepage distances for sinusoidal or non-sinusoidal working voltages at different frequency ranges; basic or supplementary insulation

| Peak value of the working voltage \hat{U}_{out} kV | Creepage distances (pollution degree 2) mm | | | |
|------------------------------------------------------------|-----------------------------------------------|-------------------------------|-------------------------------|-------------------------------|
| | 30 kHz $\leq f \leq 100$ kHz | 100 kHz $< f \leq 200$ kHz | 200 kHz $< f \leq 400$ kHz | 400 kHz $< f \leq 700$ kHz |
| 0,1 | 0,02 | a | a | a |
| 0,2 | 0,05 | a | a | a |
| 0,3 | 0,10 | 0,11 | 0,11 | 0,11 |
| 0,4 | 0,15 | 0,16 | 0,18 | 0,23 |
| 0,5 | 0,22 | 0,23 | 0,30 | 0,48 |
| 0,6 | 0,32 | 0,33 | 0,48 | 1,02 |
| 0,7 | 0,43 | 0,46 | 0,82 | 2,30 |
| 0,8 | 0,54 | 0,66 | 1,32 | 4,56 |
| 0,9 | 0,63 | 0,98 | 2,28 | a |
| 1,0 | 0,72 | 1,38 | 3,60 | a |
| 1,1 | 0,82 | 2,04 | 6,00 | a |
| 1,2 | 1,02 | 2,88 | 9,84 | a |
| 1,3 | 1,44 | 4,20 | a | a |
| 1,4 | 1,98 | 6,00 | a | a |
| 1,5 | 2,76 | 8,76 | a | a |
| 1,6 | 3,78 | a | a | a |
| 1,7 | 5,28 | a | a | a |
| 1,8 | 7,32 | a | a | a |

Linear interpolation between columns and rows is allowed. The values listed in the columns are valid for the maximum frequency of this column.

For the creepage distances the peak voltage of the working voltage is applied. Transients or small peaks (ignition voltages) which do not significantly increase the r.m.s. of the declared working voltage U_{out} are neglected.

For reinforced insulation the doubled values of the basic or supplementary insulation are required.

NOTE In Japan and North America, the values defined are not applicable. Japan and North America requires larger values.

^a No values available.

16.2.4 Compliance with the required creepage distances

Compliance is checked by measurements made with and without conductors of the largest section connected to the terminals of the controlgear.

The contribution to the creepage distance of any groove less than 1 mm wide is limited to its width.

For controlgear provided with an appliance inlet, the measurements are made with an appropriate connector inserted.

Distances through slots or openings in external parts of insulating material are measured with metal foil in contact with the accessible surface. The foil is pushed into corners and similar places by means of the standard test finger specified in IEC 60529, but it is not pressed into openings.

Creepage distances at a supply terminal shall be measured from the live part in the terminal to any accessible metal parts.

When creepage distances are determined at bushings, cord anchorages, wire carriers or clips, the measurement shall be made with the cable fitted.

16.3 Clearances

16.3.1 General

The minimum values for clearances are listed in Tables 9, 10 and 11. The values for clearances are divided into categories for basic or supplementary and reinforced insulation.

The values of the minimum clearances for working voltages are specified according to the information given in 16.1 and 3.42. Lamp controlgears shall only be considered under the aspect of transients which are defined for the connected mains supply.

For clearance values the following parameters are important (in addition to the parameter described in 16.1):

- the condition of the electric field – for controlgear interfaces, inhomogeneous fields have to be considered;
- the occurring voltages in combination with the frequency of the occurring voltage.

Guidance for the use of the Tables 9, 10 and 11 is given in Figure 5 and 6. Peak voltages are incorporated in the assessment of clearances. Figure 6 shows the application alternative for the primary and the secondary side.

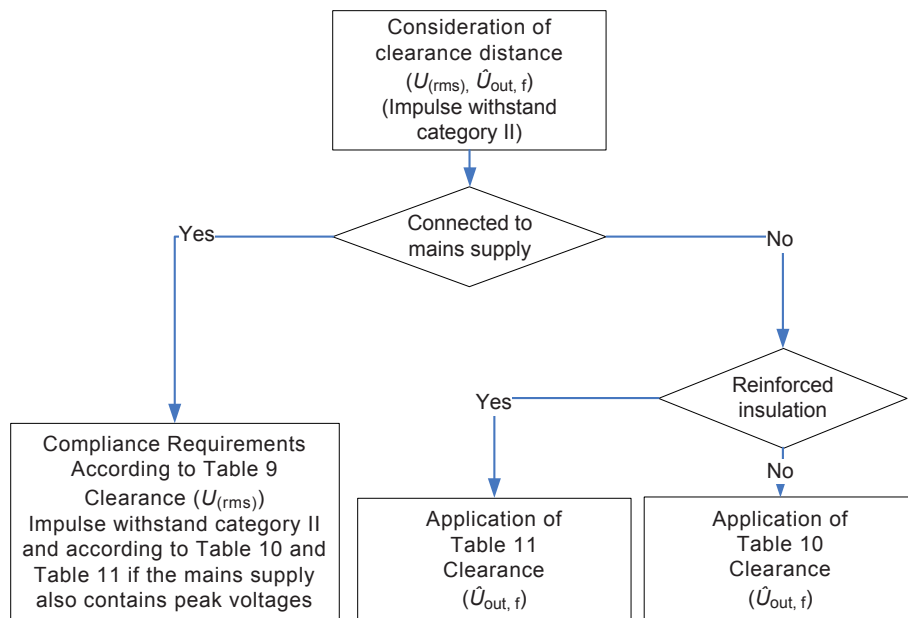

IEC

Figure 5 – Application of Table 9, Table 10 and Table 11

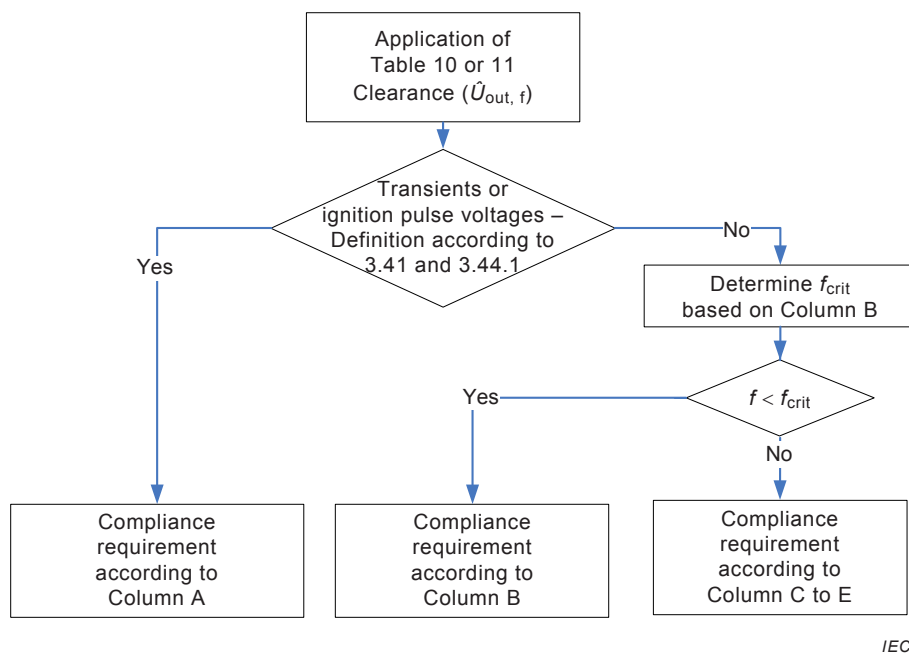

IEC

Figure 6 – Application of Table 10 and Table 11

The clearance shall be measured between incoming supply wiring and accessible metal parts, i.e. from a bare conductor of the largest section to the metal parts which can be accessible. At the internal wiring side of the terminal the clearance shall be measured between live parts of the terminal and accessible metal parts (see Figure 24 of IEC 60598-1:2014).

16.3.2 Clearances for working voltages

Table 9 presents clearance values for working voltages.

Table 9 – Minimum clearances for working voltages

| Distances ^a mm | RMS working voltage not exceeding V | | | | | |
|--------------------------------------------------------------------------------------------------------------------------------------------------------------------------------------------------------------------------------------------------------------------------------------------------------------|----------------------------------------|-----|-----|-----|-----|-------|
| | 50 | 150 | 250 | 500 | 750 | 1 000 |
| Clearances with mains supply transients according to impulse withstand category II ^a | | | | | | |
| – Basic or supplementary insulation | 0,2 | 0,5 | 1,5 | 3 | 5,5 | 5,5 |
| – Reinforced insulation | 0,4 | 1,6 | 3 | 5,5 | 8 | 8 |
| Clearances without mains supply transients ^a | | | | | | |
| – Basic or supplementary insulation | 0,2 | 0,2 | 0,2 | 0,2 | 0,3 | 0,7 |
| – Reinforced insulation | 0,2 | 0,2 | 0,2 | 0,4 | 1,0 | 1,6 |
| Interpolation between columns is not allowed, if transients according to the impulse withstand category II have to be considered for the main supply. | | | | | | |
| These values are applicable to controlgear output circuit where the working voltage is higher than the rated input voltage and where the clearance required is higher than the clearance with mains supply transient or in case of output where controlgear manufacturer ensures it is free from transients. | | | | | | |
| NOTE In Japan and North America, these values are not applicable. Japan and North America requires larger values. | | | | | | |
| ^a For clearances, the equivalent d.c. voltage is equal to the peak of the a.c. voltage. | | | | | | |

No values are specified for working voltages below 25 V a.c. and 60 V ripple free d.c.

16.3.3 Clearances for ignition voltages and working voltages with higher frequencies

Minimum distances for sinusoidal or non-sinusoidal ignition voltages or working voltages with higher frequencies are given in Table 10 for basic or supplementary insulation and in Table 11 for reinforced insulation.

Column A specifies clearance values for ignition pulse voltages with a total time of all pulses $\leq 0,75$ ms within 10 ms (summation of all pulses). Column B gives the clearance for frequencies below or equal to f_{crit} (where $f_{\text{crit}} = 0,2 \text{ MHz/d [mm]}$). Columns C to E give clearances for several frequency ranges.

Columns B to E in Tables 10 and 11 specify clearances for ignition voltages to grow wider than 0,75 ms (summation of all pulses) within 10 ms or for working voltages with higher frequencies than 30 kHz.

Column B gives clearance values until f_{crit} . The calculation of the critical frequency f_{crit} , at which the reduction of the breakdown voltage begins, is defined as follows:

$$f_{\text{crit}} \approx 0,2/d \text{ [MHz]}$$

where

d (in mm) is the clearance according to the Table 10 column B (basic or supplementary insulation) and to Table 11 column B (reinforced insulation) disregarding the frequency.

For details of f_{crit} , IEC 60664-4 should be consulted.

Columns C to E in Tables 10 and 11 specify clearances for ignition voltages in the frequency range from f_{crit} to 700 kHz or for working voltages with higher frequencies than f_{crit} .

Table 10 – Minimum distances of clearances for sinusoidal or non-sinusoidal voltages; inhomogeneous field conditions; basic or supplementary insulation

| Voltage ^a \dot{U}_{out} kV | A | B | C | D | E |
|------------------------------------------------------------------------------------------------------------------------------------------------------------------------------------------------------------|-----------------------------------------|-------------------------------------|------------------------|-------------------------------|-------------------------------|
| | | | $f \leq 200$ kHz | 200 kHz < $f \leq 400$ kHz | 400 kHz < $f \leq 700$ kHz |
| | | $f \leq f_{crit}$ | $f > f_{crit}$ | | |
| | Transients or ignition pulse voltage | Ignition voltage or working voltage | | | |
| | Minimum distances mm | | | | |
| 0,33 | 0,2 | 0,01 0,26 | 0,01 | 0,01 | 0,01 |
| 0,4 | | 0,02 | 0,02 | 0,02 | 0,02 |
| 0,5 | | 0,05 | 0,05 | 0,05 | 0,05 |
| 1,0 | 0,26 | 0,26 | 0,26 | 0,26 | 0,26 |
| 1,5 | 0,5 | 0,76 | 0,76 | 0,84 | 1,00 |
| 2,0 | 1,0 | 1,27 | 1,30 | 1,45 | 1,67 |
| 2,5 | 1,5 | 1,8 | 1,89 | 2,10 | 2,41 |
| 3,0 | 2,0 | 2,4 | 2,57 | 2,86 | 3,29 |
| 4,0 | 3,0 | 3,8 | 4,18 | 4,70 | 5,47 |
| 5,0 | 4,0 | 5,7 | 6,31 | 7,05 | 8,09 |
| 6,0 | 5,5 | 7,9 | 8,45 | 9,07 | 10,0 |
| 8,0 | 8,0 | 11,0 | b | b | b |
| 10,0 | 11 | 15,2 | b | b | b |
| 12,0 | 14 | 19 | b | b | b |
| 15,0 | 18 | 25 | b | b | b |
| 20,0 | 25 | 34 | b | b | b |
| 25,0 | 33 | 44 | b | b | b |
| 30,0 | 40 | 55 | b | b | b |
| 40,0 | 60 | 77 | b | b | b |
| 50,0 | 75 | 100 | No values available | No values available | No values available |
| 60,0 | 90 | No values available | | | |
| 80,0 | 130 | | | | |
| 100,0 | 170 | | | | |
| For distances subjected to both sinusoidal voltage as well as non-sinusoidal pulses, the minimum required distance shall be not less than the highest value indicated in either one of the Tables 9 or 10. | | | | | |
| ^a The clearances for other voltages are obtained by linear interpolation. | | | | | |
| ^b Values under consideration. | | | | | |

Table 11 – Minimum distances of clearances for sinusoidal or non-sinusoidal voltages; inhomogeneous field conditions; reinforced insulation

| Voltage ^a \hat{U}_{out} kV | A | B | C | D | E |
|------------------------------------------------------------------------------------------------------------------------------------------------------------------------------------------------------------|-----------------------------------------|-------------------------------------|------------------------|-------------------------------|-------------------------------|
| | | $f \leq f_{crit}$ | $f \leq 200$ kHz | 200 kHz < $f \leq 400$ kHz | 400 kHz < $f \leq 700$ kHz |
| | Transients or ignition pulse voltage | Ignition voltage or working voltage | | | |
| | Minimum distances mm | | | | |
| 0,33 | 0,2 | 0,06 | 0,06 | 0,06 | 0,06 |
| 0,4 | | 0,08 | 0,08 | 0,08 | 0,08 |
| 0,5 | | 0,10 | 0,10 | 0,10 | 0,10 |
| 1,0 | 0,6 | 0,87 | 0,87 | 0,96 | 1,14 |
| 1,5 | 1,4 | 1,7 | 1,77 | 1,96 | 2,26 |
| 2,0 | 2,2 | 2,7 | 2,9 | 3,2 | 3,7 |
| 2,5 | 3,0 | 3,8 | 4,2 | 4,7 | 5,5 |
| 3,0 | 3,8 | 5,3 | 5,8 | 6,5 | 7,7 |
| 4,0 | 6,0 | 8,5 | 9,1 | 9,8 | 10,8 |
| 5,0 | 8,0 | 11,0 | 12,1 | 13,2 | 14,9 |
| 6,0 | 10,4 | 14,3 | 15,6 | 16,8 | 18,6 |
| 8,0 | 15,0 | 20,6 | b | b | b |
| 10,0 | 19,4 | 26,8 | b | b | b |
| 12,0 | 24,0 | 32,5 | b | b | b |
| 15,0 | 31,4 | 42,0 | b | b | b |
| 20,0 | 44 | 59,4 | b | b | b |
| 25,0 | 60 | 77,0 | b | b | b |
| 30,0 | 72 | 95,4 | No values available | No values available | No values available |
| 40,0 | 98 | | | | |
| 50,0 | 130 | | | | |
| 60,0 | 162 | | | | |
| 80,0 | No values available | | | | |
| 100,0 | | | | | |
| For distances subjected to both sinusoidal voltage as well as non-sinusoidal pulses, the minimum required distance shall be not less than the highest value indicated in either one of the Tables 9 or 11. | | | | | |
| ^a The clearances for other voltages are obtained by linear interpolation | | | | | |
| ^b Values under consideration | | | | | |

16.3.4 Compliance with the required clearances

Compliance is checked by measurements made with and without conductors of the largest section connected to the terminals of the lamp controlgear.

For controlgear provided with an appliance inlet, the measurements are made with an appropriate connector inserted.

Distances through slots or openings in external parts of insulating material are measured with metal foil in contact with the accessible surface. The foil is pushed into corners and similar

places by means of the standard test finger specified in IEC 60529, but it is not pressed into openings.

NOTE The measurements of the clearances from supply and from internal wiring differ because the controlgear manufacturer does not have control over the length of insulation removed from the supply wiring by the installer.

At the internal wiring side of the terminal, the clearance shall be measured between live parts of the terminal and accessible metal parts (see Figure 24 of IEC 60598-1:2014).

17 Screws, current-carrying parts and connections

Screws, current-carrying parts and mechanical connections, the failure of which might cause the lamp controlgear to become unsafe, shall withstand the mechanical stresses occurring in normal use.

Compliance is checked by inspection and the tests of 4.11 and 4.12 of IEC 60598-1:2014.

18 Resistance to heat, fire and tracking

18.1 Parts of insulating material either retaining live parts in position or providing protection against electric shock shall be sufficiently resistant to heat.

For materials other than ceramic, compliance is checked by subjecting the parts to the ball-pressure test according to Section 13 of IEC 60598-1:2014.

18.2 External parts of insulating material providing protection against electric shock and parts of insulating material retaining live parts in position shall be sufficiently resistant to flame and ignition/fire.

For materials other than ceramic, compliance is checked by the tests of 18.3 or 18.4, as appropriate.

Printed circuit boards are not tested as above, but in accordance with 8.7 of IEC 61189-2:2006 and the relevant parts of IEC 61249-2 series. Any self-sustaining flame shall extinguish within 30 s of removal of the gas flame and any flaming drops shall not ignite the tissue paper specified.

18.3 External parts of insulating material providing protection against electric shock shall be subjected for 30 s to the glow-wire test in accordance with IEC 60695-2-10, subject to the following details:

- the test sample shall be one specimen;
- the test specimen shall be a complete lamp controlgear;
- the temperature of the tip of the glow-wire shall be 650 °C;
- any (self-sustaining) flame or glowing of the specimen shall extinguish within 30 s of removal of the glow wire and any flaming drops shall not ignite a piece of tissue paper, as specified in 4.187 of ISO 4046-4:2002, spread out horizontally 200 mm ± 5 mm below the test specimen.

18.4 Parts of insulating material retaining live parts in position shall be subjected to the needle-flame test in accordance with IEC 60695-11-5, subject to the following details:

- the test sample shall be one specimen;
- the test specimen shall be a complete lamp controlgear. If it is necessary to take away parts of the lamp controlgear to perform the test, care shall be taken to ensure that the test conditions are not significantly different from those occurring in normal use;

- the test flame is applied to the centre of the surface to be tested;
- the duration of application is 10 s;
- any self-sustaining flame shall extinguish within 30 s of removal of the gas flame, and any flaming drops shall not ignite a piece of tissue paper as specified in 4.187 of ISO 4046-4:2002, spread out horizontally 200 mm \pm 5 mm below the test specimen.

18.5 Lamp controlgear intended for building into luminaires other than ordinary, independent lamp controlgear, and lamp controlgear having insulation subject to starting voltages with a peak value higher than 1 500 V shall be resistant to tracking.

For materials other than ceramic, compliance is checked by subjecting the parts to the tracking test according to Section 13 of IEC 60598-1:2014.

19 Resistance to corrosion

Ferrous parts, the rusting of which might cause the lamp controlgear to become unsafe, shall be adequately protected against rusting.

Compliance is checked by the test of 4.18.1 of IEC 60598-1:2014.

Protection by varnish is deemed to be adequate for the outer surfaces.

20 No-load output voltage

The requirements of this clause are only applicable for magnetic lamp controlgear with integrated transformer, operating with supply frequencies.

If a magnetic lamp controlgear is connected at rated supply voltage and rated frequency with no-load on the output, the output voltage shall not differ from the rated value of the no-load output voltage declared by the manufacturer by more than 10 %.

Annex A (normative)

Test to establish whether a conductive part is a live part which may cause an electric shock

A.1 General test requirements

In order to determine whether a conductive part is a live part which may cause an electric shock, the device under test (DUT) is operated at rated voltage and nominal supply frequency. A conductive part is not a live part if the requirements of Clauses A.2 or A.3 are met.

NOTE The purpose of this annex is to establish if a conductive part can cause an electric shock, if touched. It does not give response about the kind and level of insulation used.

For the tests according to Clauses A.2 and A.3:

- one pole of the supply of the DUT shall be at earth potential;
- if no explicit designation of the supply voltage polarity is marked on the DUT, the test is done with both supply voltage polarities;
- the measurements are undertaken:
 - between the part concerned and any accessible conductive part;
 - between the part concerned and earth.

A.2 Limits for measured voltages

The voltage is measured by using a measuring circuit consisting of a non-inductive resistance of 50 k Ω and the voltage shall not exceed:

- 35 V a.c. peak or 60 V ripple free d.c.

A.3 Limits for touch current

Where the voltage measured according Clause A.2 exceeds the limit value, the touch-current shall not exceed:

- for a.c.: 0,7 mA (peak),
- for d.c.: 2,0 mA.

Compliance is checked by using the measuring network from Figure G.2 of IEC 60598-1:2014.

Annex B (normative)

Particular requirements for thermally protected lamp controlgear

B.1 Introductory remark

Two different categories of thermally protected lamp controlgear are covered by this annex. The first category comprises "class P" (according to B.9.2) USA lamp controlgear, referred to in this standard as "protected lamp controlgear", which are intended to prevent lamp controlgear overheating under any conditions of use including protection of the luminaire mounting surface against overheating due to end-of-life effects.

The second category comprises "temperature declared thermally protected lamp controlgear" (according to B.9.3, B.9.4 and B.9.5). This category provides thermal protection of the mounting surface which, depending on the marked operating temperature of the thermal protection in combination with the luminaire construction, provides protection against overheating due to end-of-life effects on the lamp controlgear.

NOTE A third category of thermal lamp controlgear protection is recognized where the thermal protection of the mounting surface is achieved by a thermal protector external to the lamp controlgear. Relevant requirements can be found in IEC 60598-1.

The clauses listed in this annex supplement the corresponding clauses in the main part of the standard. Where there is no corresponding clause or subclause in this annex, the clause or subclause of the main part applies without modification.

B.2 General

This annex applies to lamp controlgear for discharge lamps, intended to be built into luminaires and incorporating a means of thermal protection that is intended to disconnect the supply circuit to the lamp controlgear before the lamp controlgear case temperature exceeds the specified limits.

B.3 Terms and definitions

For the purposes of this annex, the following terms and definitions apply.

B.3.1

"class P" thermally protected lamp controlgear



lamp controlgear incorporating a thermal protector which is intended to prevent overheating under any conditions of use and which will protect the luminaire mounting surface against overheating due to end-of-life effects

Note 1 to entry: This symbol is under development as IEC 60417-Pr14-171.

B.3.2

temperature declared thermally protected lamp controlgear



lamp controlgear incorporating means of protection against overheating to prevent the lamp controlgear case temperature under any conditions of use from exceeding the indicated value

Note 1 to entry: This symbol is under development as IEC 60417-Pr14-172.

Note 2 to entry: The dots in the triangle are replaced by the value of the rated maximum case temperature in degrees Celsius at any place on the outer surface of the lamp controlgear case, as claimed by the manufacturer under the conditions in Clause B.9.

Note 3 to entry: Lamp controlgear marked with values equal to or below 130 are deemed to comply with the requirements of overheating of the mounting surface for luminaire classified as suitable for mounting on a normally flammable surface in accordance with 4.16 of IEC 60598-1:2014 without any further test.

B.3.3

rated opening temperature

no-load temperature at which a protector is designed to open

B.4 General requirements for thermally protected lamp controlgear

Thermal protectors shall be an integral part of lamp controlgear and located so as to be protected against mechanical damage. Renewable parts, if any, shall only be accessible by means of a tool.

If functioning of the protection means depends on polarity, then for cord-connected equipment where the plug is not polarized, the protection shall be in both leads.

Compliance is checked by inspection and by the tests of IEC 60730-2-3 or IEC 60691, as appropriate.

B.5 General notes on tests

The appropriate number of specially prepared samples according to Clause B.9 shall be submitted.

Only one sample need be subjected to the most onerous fault condition described in B.9.2 and only one sample need be subjected to the conditions described in B.9.3 or B.9.4. In addition, for both protected and temperature-declared lamp controlgear, at least one lamp controlgear shall be submitted, prepared to represent the most onerous of the fault conditions described in B.9.2.



B.6 Classification

B.6.1 General

Lamp controlgear are classified according to B.6.2 or B.6.3.

B.6.2 According to the class of protection

According to the class of protection, lamp controlgear are classified into:

- a) "class P" thermally protected lamp controlgear, symbol ; or
- b) temperature declared thermally protected lamp controlgear, symbol .

B.6.3 According to the type of protection



According to the type of protection, lamp controlgear are classified into:

- a) automatic resetting (cyclic) type;
- b) manual resetting (cyclic) type;
- c) non-renewable, non-resetting (fuse) type;

- d) renewable, non-resetting (fuse) type; or
- e) other type of protective method providing equivalent thermal protection.

B.7 Marking

B.7.1 Lamp controlgear incorporating means of protection against overheating shall be marked, according to the class of protection, with:

- the symbol  for "class P" thermally protected lamp controlgear;
- the symbol  for temperature declared thermally protected lamp controlgear, values increasing in multiples of 10.

The terminal(s) to which the protector(s) is(are) connected shall be identified by this symbol.

In addition, for renewable protectors, the marking shall include the type of protector to be used.

This marking is required by the luminaire manufacturer to ensure that the marked terminal is not connected to the lamp side of the lamp controlgear.

NOTE Local wiring rules may require the protector to be connected in the line conductor. This is essential in class I equipment where polarized supplies are used.

B.7.2 In addition to the above marking, the lamp controlgear manufacturer shall declare the type of protection in accordance with B.6.3.

B.8 Thermal endurance of windings

Lamp controlgear incorporating a thermal protector shall comply with the thermal endurance test of windings with the protector short-circuited.

NOTE For type testing, the manufacturer can be asked to supply samples with short-circuited protectors.

B.9 Lamp controlgear heating

B.9.1 Preselection test

Before starting the tests of this clause, the lamp controlgear shall be placed (non-energized) for at least 12 h in an oven, the temperature of which is maintained at 5 K less than the rated operating temperature of the protector.

In addition, lamp controlgear with thermal fuses are allowed to cool to a temperature at least 20 K less than the rated operating temperature of the protector before being removed from the oven.

At the end of this period, a small current, for example not more than 3 % of the nominal supply current of the lamp controlgear, shall be passed through the lamp controlgear in order to determine whether the protector is closed.

Lamp controlgear in which the protector has operated shall not be used for further testing.

B.9.2 "Class P" thermally protected lamp controlgear

B.9.2.1 These lamp controlgear are limited to a maximum case temperature of the lamp controlgear of 90 °C, a rated maximum winding temperature (t_w) of 105 °C and a capacitor rated maximum operating temperature (t_c) of 70 °C.

NOTE These lamp controlgear are suited to present practice in the USA.

The lamp controlgear is operated at thermal equilibrium under normal conditions in the test enclosure of which a typical example is described in Annex D, at an ambient temperature of 40^{+0}_{-5} °C.

The protector shall not open under these conditions of operation.

The most onerous of the following fault conditions shall then be introduced and applied throughout the complete test.

To obtain these conditions, specially prepared lamp controlgear will be necessary.

B.9.2.2 For transformers, the following relevant abnormal conditions apply (in addition to those specified in Annex C of IEC 60598-1:2014):

a) For lamp controlgear specified in IEC 61347-2-8:

- the outer 10 % of the turns of primary winding is short-circuited;
- the outer 10 % of the turns of any secondary power winding is short-circuited;
- any power capacitor is short-circuited, if such condition will not short-circuit the ballast primary winding.

b) For lamp controlgear specified in IEC 61347-2-9:

- the outer 20 % of the turns of primary winding is short-circuited;
- the outer 20 % of the turns of any secondary power winding is short-circuited;
- any power capacitor is short-circuited, if such condition will not short-circuit the ballast primary winding.

B.9.2.3 For chokes, the following abnormal conditions apply (in addition to those specified in Annex C of IEC 60598-1:2014):

a) For lamp controlgear specified in IEC 61347-2-8:

- the outer 10 % of the turns of each winding is short-circuited;
- a series capacitor is short-circuited, if applicable.

b) For lamp controlgear specified in IEC 61347-2-9:

- the outer 20 % of the turns of each winding is short-circuited;
- a series capacitor is short-circuited, if applicable.

Three cycles of heating and cooling shall be applied for the purpose of this measurement. For non-resetting type protectors, only one cycle shall be applied on each specially prepared lamp controlgear.

Temperatures on the case of the lamp controlgear shall continue to be measured after the protector opens. Except when testing for protector reclosing temperatures, the test may be discontinued when case temperatures start to decrease following the opening of the protector, or when the specified temperature limit is exceeded.

NOTE If the case reaches a temperature not exceeding 110 °C and either remains at that temperature or starts to decrease, the test can be discontinued after 1 h of operation after the peak temperature is first reached.

During the test, the temperature on the case of the lamp controlgear shall not exceed 110 °C and shall be no more than 85 °C when the protector recloses the circuit (with a resetting type protector), except that, during any cycle of operation of the protector during the test, the case temperature may be more than 110 °C, provided that the length of time between the instant when the case temperature first exceeds the limit and the instant of attainment of the maximum temperature indicated in Table B.1 does not exceed the time correspondingly indicated in that table.

The temperature on the enclosure of a capacitor provided as part of such lamp controlgear shall be no more than 90 °C except that the capacitor temperature may be more than 90 °C when the case temperature is more than 110 °C.

Table B.1 – Thermal protection operation

| Maximum temperature of the lamp controlgear case °C | Maximum time for attainment of the maximum temperature from 110 °C min |
|--------------------------------------------------------|---------------------------------------------------------------------------|
| Over 150 | 0 |
| Between 145 and 150 | 5,3 |
| Between 140 and 145 | 7,1 |
| Between 135 and 140 | 10 |
| Between 130 and 135 | 14 |
| Between 125 and 130 | 20 |
| Between 120 and 125 | 31 |
| Between 115 and 120 | 53 |
| Between 110 and 115 | 120 |

B.9.3 Temperature declared thermally protected lamp controlgear as specified in IEC 61347-2-8, with a rated maximum case temperature of 130 °C or lower

The lamp controlgear is operated at thermal equilibrium under normal conditions in the test enclosure described in Annex D, in an ambient temperature such that a winding temperature of $(t_w + 5)$ °C is obtained.

The protection means shall not operate under these conditions.

The most onerous of the fault conditions described in B.9.2 shall then be introduced and applied throughout the complete test.

It is permitted to operate the lamp controlgear at a current producing a winding temperature equivalent to that of the most onerous of the fault conditions described in B.9.2.

During the test, the temperature on the case of the lamp controlgear shall not exceed 135 °C and shall be no more than 110 °C when the protector recloses the circuit (with a resetting type protector). However, during any cycle of operation of the protector during the test, the case temperature may be more than 135 °C, provided that the length of time between the instant when the case temperature first exceeds the limit and the instant of attainment of the maximum temperature indicated in Table B.2 does not exceed the time corresponding to that indicated in that table.

The temperature on the enclosure of a capacitor provided as part of such a lamp controlgear shall be no more than 50 °C or t_c under conditions of normal operation and not more than 60 °C or $(t_c + 10)$ °C under conditions of abnormal operation for capacitors with or without indication of rated maximum operating temperature (t_c) respectively.

Table B.2 – Thermal protection operation

| Maximum temperature of the lamp controlgear case °C | Maximum time for attainment of the maximum temperature from 135 °C min |
|--------------------------------------------------------|---------------------------------------------------------------------------|
| Over 180 | 0 |
| Between 175 and 180 | 15 |
| Between 170 and 175 | 20 |
| Between 165 and 170 | 25 |
| Between 160 and 165 | 30 |
| Between 155 and 160 | 40 |
| Between 150 and 155 | 50 |
| Between 145 and 150 | 60 |
| Between 140 and 145 | 90 |
| Between 135 and 140 | 120 |

B.9.4 Temperature declared thermally protected lamp controlgear as specified in IEC 61347-2-8 with a rated maximum case temperature exceeding 130 °C

The tests for thermally protected lamp controlgear are specified as follows.

- a) *The lamp controlgear shall be operated at thermal equilibrium under conditions as specified in Clause D.4 at a short-circuit current producing a winding temperature of $(t_w + 5)$ °C.*

The protection means shall not open under this condition.

- b) *The lamp controlgear shall then be operated at a current producing a winding temperature identical to that under the most onerous of the fault conditions described in B.9.2.*

During the test, the lamp controlgear case temperature shall be measured.

Then, if necessary, the current through the windings shall be increased slowly and continuously until the protection means operates.

Time intervals and increments in current shall be such that thermal equilibrium between winding temperatures and lamp controlgear surface temperatures is achieved as far as is possible.

During the test, the highest temperature of the lamp controlgear surface shall be continuously measured.

For lamp controlgear fitted with automatic resetting thermal cut-outs/protectors (see item a) of B.6.3) or protective mechanism of another type (see item e) of B.6.3), the test shall be continued until stable surface temperature is achieved.

The automatic-resetting thermal cut-out/protector shall work three times by switching the lamp controlgear off and on under the given conditions.

For lamp controlgear fitted with manual reset thermal cut-outs/protectors, the test shall be repeated three times allowing a 30-min interval between tests. At the end of each 30 min interval, the cut-outs/protectors shall be reset.

For lamp controlgear fitted with non-renewable, non-resetting type, and for lamp controlgear with renewable type of thermal protectors, only one test is carried out.

Compliance is achieved if the highest temperature of any part of the lamp controlgear surface does not exceed the marked value.

An overshoot of 10 % of the declared value is permissible within 15 min after the protection means has operated. After that period, the declared value shall not be exceeded.

B.9.5 Temperature declared thermally protected lamp controlgear as specified in IEC 61347-2-9

B.9.5.1 General

The lamp controlgear shall be equipped with a thermal protector. When tested in accordance with the requirements given in B.9.5.1 to B.9.5.3, using the test circuit shown in Figure B.1, the highest temperature of any part of the lamp control gear surface shall not exceed the marked value of t_c , except within 15 min of the thermal protector operating, when an overshoot of 10 % of the marked value of t_c is permitted.

Series capacitors, if any, shall be short-circuited during the tests.

During the test, the winding temperature and the highest temperature of any part of the lamp controlgear surface shall be continuously measured.

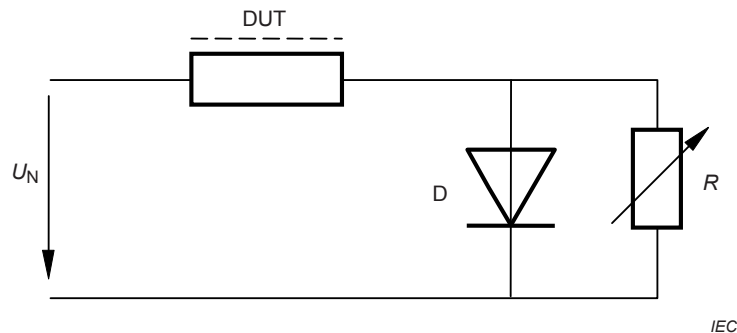

Key

| | |
|-------|----------------------------------------------|
| DUT | device under test |
| D | diode, 100 A, 600 V |
| R | resistor, 0 to 200 Ω (1/2 lamp power) |
| U_N | test voltage |

Figure B.1 – Test circuit for thermally protected lamp controlgear

B.9.5.2 Test sequence

The test sequence for the normal winding temperature conditions and the function of the thermal protector is described as follows.

a) Test of the normal winding temperature conditions plus 20 K

The lamp controlgear shall be operated at thermal equilibrium, under conditions as specified in Clause H.12, at a short-circuit current (tuned with resistor R) producing a winding temperature of $(t_w + 20)$ °C. The thermal protector shall not open under this condition.

The current I_{tw+20} shall be recorded as a basic current for the test b).

b) Function test of the thermal protector – Control of the marked t_c temperature limitation

After the test under normal winding temperature conditions with $(t_w + 20)$ °C, the lamp controlgear shall be operated with an increasing current (in the following steps) until the thermal protector operates.

Step one with the current of $I_{tw+20} + 5 \%$

Step two with the current of $I_{t_w+20} + 10\%$

Step three with the current of $I_{t_w+20} + 15\%$, etc.

The procedure of increasing the current in steps of 5 % shall be used until the thermal protector operates and switches off the contacts.

Between each step, the time taken for the thermal stabilization of the lamp controlgear shall be observed.

NOTE In Japan, $(t_w + 5)^\circ\text{C}$ is required instead of $(t_w + 20)^\circ\text{C}$ for this test.

B.9.5.3 Test cycle

The test cycle for different thermal protected controlgear types is as follows.

- a) Lamp controlgear with automatic resetting thermal protectors according to B.6.3 a) or with a protective method of another type according to B.6.3 e)

For lamp controlgear fitted with automatic resetting thermal protectors, or with a protective method of another type, the test shall be continued until a stable surface temperature is achieved. The automatic setting thermal protector shall work at least three times by switching the lamp controlgear off and on under the given conditions.

- b) Lamp controlgear with a manual resetting thermal protector according to B.6.3 b)

For lamp controlgear fitted with a manual resetting thermal protector, the test shall be repeated three times, allowing a 30 min interval between the tests. At the end of each 30 min interval, the cut-outs shall be reset.

- c) Lamp controlgear with non-renewable, non-resetting thermal protectors according to B.6.3 c) and with renewable types of thermal protectors according to B.6.3 d)

For lamp controlgear fitted with non-renewable, non-resetting type, and for lamp controlgear with renewable types of thermal protectors, only one test shall be carried out.

- d) Lamp controlgear with a combination of the protective devices

For lamp controlgear where a combination of the protective devices mentioned is used, the lamp controlgear shall be tested as for the protective device that provides the primary protection for temperature control, as declared by the manufacturer.

Annex C (normative)

Particular requirements for electronic lamp controlgear with means of protection against overheating

C.1 General

This annex applies to electronic lamp controlgear incorporating a means of thermal protection that is intended to open the supply circuits to the lamp controlgear before the lamp controlgear case temperature exceeds the declared limits.

C.2 Terms and definitions

For the purposes of this annex, the following terms and definitions apply.

C.2.1

temperature declared thermally protected lamp controlgear



lamp controlgear incorporating means of protection against overheating to prevent the lamp controlgear case temperature exceeding the indicated value

Note 1 to entry: This symbol is under development as IEC 60417-Pr14-172.

Note 2 to entry: The three dots in the triangle are replaced by the value of the rated maximum case temperature in degrees Celsius at any place on the outer surface of the lamp controlgear case as claimed by the manufacturer under the conditions in Clause C.7.

Note 3 to entry: Lamp controlgear marked with values up to 130 provide protection against overheating due to end-of-life effects.

Note 4 to entry: Lamp controlgear marked with values equal to or below 130 are deemed to comply with the requirements of overheating of the mounting surface for luminaire classified as suitable for mounting on a normally flammable surface in accordance with 4.16 of IEC 60598-1:2014 without any further test.

C.3 General requirements for electronic lamp controlgear with means of protection against overheating

C.3.1 Thermal protection means shall be an integral part of lamp controlgear and located so as to be protected against mechanical damage. Renewable parts, if any, shall be accessible only by means of a tool.

If the functioning of the protection means depends on polarity, then, for cord-connected equipment where the plug is not polarized, the protection shall be in both leads.

Compliance is checked by inspection and by the tests of IEC 60730-2-3 or IEC 60691, as appropriate.

C.3.2 The circuit breaking of the protection means shall not give rise to any fire risk.

Compliance is checked by the tests of Clause C.7.

C.4 General notes on tests

The appropriate number of specially prepared samples according to Clause C.7 shall be submitted.

Only one sample need be subjected to the most onerous fault conditions described in C.7.2.

C.5 Classification

Thermally protected lamp controlgear are classified according to the type of protection as follows:

- a) automatic resetting type;
- b) manual resetting type;
- c) non-renewable, non-resetting type;
- d) renewable, non-resetting type;
- e) protective method of another type providing equivalent thermal protection.

C.6 Marking

Thermally protected lamp controlgear shall be marked as follows.

C.6.1 The symbol  is used for temperature declared thermally protected lamp controlgear, values increasing in multiples of 10.

C.6.2 In addition to the above marking, the lamp controlgear manufacturer shall declare the type of protection in accordance with Clause C.5. This information may be given in the manufacturer's catalogue or similar.

C.7 Limitation of heating

C.7.1 Pre-selection test

Before starting the tests of this clause, the lamp controlgear shall be placed (non-energized) for at least 12 h in an oven the temperature of which is maintained at 5 K less than the case temperature t_c .

Lamp controlgear in which the protector has operated shall not be used for further testing.

C.7.2 Functioning of the protection means

The lamp controlgear is operated at thermal equilibrium under normal conditions in the test enclosure described in Annex D, at an ambient temperature such that a case temperature of $(t_c^{+0}_{-5})$ °C is obtained.

The protection means shall not operate under these conditions.

The most onerous of the fault conditions described in 14.2 to 14.5 shall then be introduced and be applied throughout the complete test.

If the lamp controlgear under test contains windings, such as filter coils for suppressing harmonics, which are connected to mains supply, the output connections of these windings shall be short-circuited and the remaining part of the lamp controlgear shall be operated as

under normal conditions. Filter coils for radio interference suppression are not subjected to the test.

NOTE This can be realized by specially prepared test samples.

Then, if necessary, the current through the windings shall be increased slowly and continuously until the protection means operates. Time intervals and increments in current shall be such that the thermal equilibrium between winding temperatures and lamp controlgear surface temperatures is achieved as far as possible. During the test, the highest temperature of the lamp controlgear surface shall be continuously measured.

For lamp controlgear fitted with automatic-resetting thermal protectors (see Clause C.5 item a)), or a protective method of another type (see Clause C.5 item e)), the test shall be continued until a stable surface temperature is achieved.

The automatic-resetting thermal protector shall work three times by switching the lamp controlgear off and on under the given conditions.

For lamp controlgear fitted with manual reset thermal protectors, the test shall be repeated six times allowing a 30-min interval between tests. At the end of each 30 min interval, the protectors shall be reset.

For lamp controlgear fitted with a non-renewable, non-resetting type protectors and for lamp controlgear with renewable type thermal protectors, only one test is carried out.

Compliance is achieved if the highest temperature of any part of the lamp controlgear surface does not exceed the marked value.

An overshoot of 10 % of the marked value is permissible within 15 min after the protection means has operated. After that period, the marked value shall not be exceeded.

Annex D (normative)

Requirements for carrying out the heating tests of thermally protected lamp controlgear

D.1 Test enclosure

The heating tests are made in an enclosure in which the temperature of the ambient air is maintained as specified (see Figure D.1). The entire test enclosure shall be constructed of heat resistant material 25 mm thick. The test compartment of this enclosure shall have internal dimensions of 610 mm × 610 mm × 610 mm. The floor of the test compartment shall measure 560 mm × 560 mm, permitting an air space of 25 mm all around the platform for circulation of the heated air. A 75 mm heater compartment shall be provided below the floor of the test area for the heating elements. One side of the test compartment may be removable, but shall be so constructed that it can be securely fastened to the remainder of the enclosure. One of the sides shall have a 150 mm square opening located centrally at the bottom edge of the test compartment, and the enclosure so constructed that the only possibility of air circulation will be through this opening. The opening shall be covered by an aluminium shield as shown in Figure D.1.

D.2 Heating of enclosure

The heat source used for the test enclosure described above shall consist of four 300 W strip heaters having approximate heating surface dimensions of 40 mm × 300 mm. These elements shall be connected in parallel to the supply source. The elements shall be mounted in the 75 mm heater compartment midway between the test compartment floor and the base, and so arranged that they form a square with the outside edge of each element 65 mm from the adjacent inside wall of the enclosure. The elements shall be controlled by a suitable thermostat.

D.3 Lamp controlgear operating conditions

During the test, the frequency of the supply circuit shall be the rated frequency of the lamp controlgear, and the voltage of the supply circuit shall be the rated supply voltage of the lamp controlgear. During the test, the temperature in the enclosure shall be maintained at 40_{-5}^{+0} °C; prior to the test, the lamp controlgear (not energized) shall be placed in the chamber for a sufficient interval of time to allow all parts to attain the temperature of the air therein. If the temperature in the chamber at the end of the test differs from that at the beginning of the test, this temperature differential shall be taken into account in determining the temperature rise of the components of the lamp controlgear. The lamp controlgear shall supply the number and size of lamps for which it is intended. Lamps shall be placed outside the enclosure.

D.4 Lamp controlgear position in the enclosure

During the test, the lamp controlgear shall be in its normal operating position supported 75 mm above the floor of the test compartment by two 75 mm wooden blocks, and shall be centrally located with respect to the sides of the enclosure. Electrical connections may be brought out of the enclosure through the 150 mm square opening illustrated in Figure D.1. During the test, the enclosure shall be so located that the shielded opening is not exposed to draughts or rapid air currents.

D.5 Temperature measurements

The average ambient temperature in the enclosure is assumed to be the average air temperature at positions not less than 76 mm from the nearest wall and on a level with the centre of the lamp controlgear.

The temperature is usually measured by a glass thermometer. An alternative sensor is a thermocouple or 'thermistor' attached to a small metal vane shielded against radiation.

Temperatures on the case are usually measured by means of thermocouples. A temperature is considered to be constant when three successive readings, taken at intervals of 10 % of the previously elapsed duration of the test (but not less than 5 min intervals), indicate no change.

Dimensions in millimetres

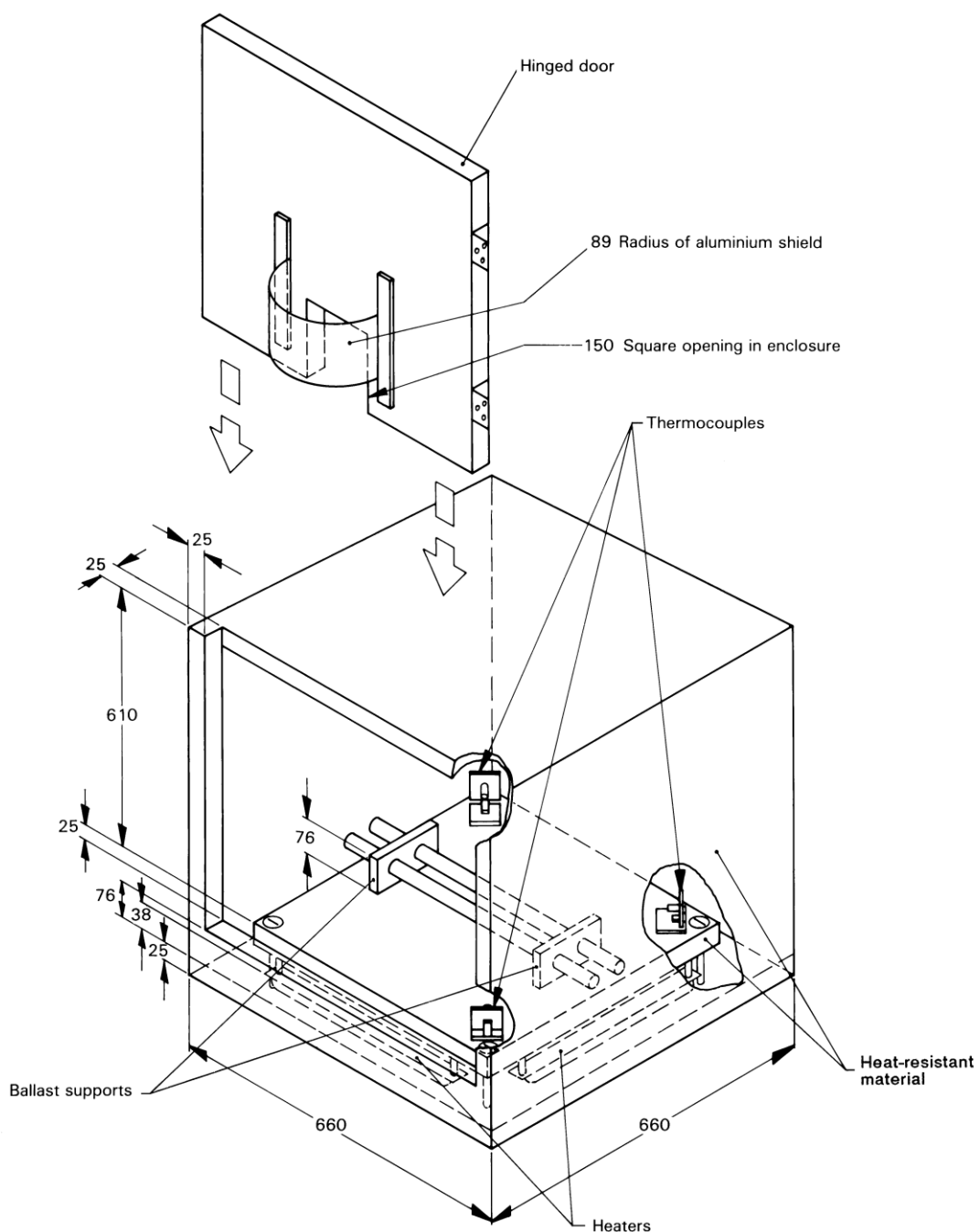

IEC

Figure D.1 – Example of heating enclosure for thermally protected ballasts

Annex E (normative)

Use of constant S other than 4 500 in t_w tests

E.1 General

The tests outlined in this annex are intended to enable the manufacturer to prove a claimed value of S other than 4 500.

Theoretical test temperatures T for use in ballast endurance tests are calculated from Equation (2) given in Clause 13.

If no claim is made to the contrary, S shall be taken to be 4 500 but a manufacturer may claim the use of any of the values in Table 4 if this can be justified by procedures A or B below.

If the use of a constant other than 4 500 for a particular ballast has been proved on the basis of procedures A or B, then that constant may be used in endurance tests for that ballast and others using the same construction and materials.

E.2 Procedure A

The manufacturer submits experimental data relating life expectancy to winding temperature for the ballast design concerned, based on enough samples, but no fewer than 30.

From this data, the regression line relating temperature T to the logarithm of life expectancy ($\log L$), together with the 95 % confidence lines associated with it, are computed.

A straight line is then drawn through the points where the 10 days and 120 days abscissae intersect the upper and lower 95 % confidence lines respectively. See Figure E.1 for a typical presentation. If the inverse of the slope of this line is greater than, or equal to, the claimed value of S , then the latter has been proved within 95 % confidence limits. For failure criteria, see procedure B.

NOTE 1 The points at 10 days and 120 days represent the smallest interval needed for the application of the confidence lines. Other points can be used provided a similar or greater interval is covered.

NOTE 2 Information in respect of the techniques involved and the method of calculating regression lines and 95 % confidence limits are given in IEC 60216-1 and in IEEE 101.

E.3 Procedure B

The manufacturer shall test 14 new ballasts in addition to those required for the endurance test, divided at random into two groups of seven. The manufacturer shall state the value of S claimed and the test temperature T_1 – required to achieve a nominal average ballast life of 10 days – together with the corresponding test temperature T_2 – for a nominal average ballast life of at least 120 days – calculated using T_1 , and the claimed value of S in the following version of Equation (2):

$$\frac{1}{T_2} = \frac{1}{T_1} + \frac{1}{S} \log \frac{120}{10} \quad \text{or} \quad \frac{1}{T_2} = \frac{1}{T_1} + \frac{1,079}{S} \quad (\text{E.1})$$

where

T_1 is the theoretical test temperature in kelvins for 10 days;

T_2 is the theoretical test temperature in kelvins for 120 days;

S is the claimed constant.

Endurance tests are then carried out using the basic method described in Clause 13 on the two groups of seven ballasts, based on the theoretical temperature T_1 (test 1) and T_2 (test 2), respectively.

If the current deviates by more than 15 % from the initial value measured 24 h after the commencement of the test, the test shall be repeated at a lower temperature. The duration of the test is calculated with the help of equation (2). Ballasts are considered to have failed if during operation in the oven

- a) the ballast becomes open-circuit;
- b) breakdown of the insulation occurs, as indicated by the operation of a fast-acting fuse with a current rating of 150 % to 200 % of the initial supply current measured after 24 h.

Test 1, the duration of which shall be equal to, or greater than, 10 days, is continued until all the ballasts have failed and the mean life L_1 has been calculated from the mean of the logarithm of the individual lives at temperature T_1 . From this, the corresponding mean life L_2 at temperature T_2 is calculated with the help of another arrangement (E.2) of Equation (2):

$$L_2 = L_1 \exp \left[\frac{S}{\log_e} \left(\frac{1}{T_2} - \frac{1}{T_1} \right) \right] \quad (\text{E.2})$$

Care should be taken to ensure that the failure of one or more of the ballasts does not affect the temperature of the remaining ballast on test.

Test 2 is continued until such time as the mean life at temperature T_2 exceeds L_2 ; this result implies that the constant S for the sample is at least that claimed. However, if all the samples in test 2 fail before the mean life reaches L_2 , then the constant S claimed for the samples has not been verified.

The test lives shall be normalized from the actual test temperature to the theoretical test temperature using the claimed constant S .

It is not generally necessary to continue test 2 until all the ballasts have failed. Calculation of the necessary duration of the test is simple but needs to be updated whenever a failure occurs.

In the case of ballasts incorporating temperature-sensitive materials, a nominal ballast life of 10 days might not be appropriate. In such cases, the manufacturer may adopt a longer life providing this is shorter than the appropriate endurance test period, for example, 30, 60, 90 or 120 days. In such cases, the longer nominal ballast life shall be at least 10 times that of the shorter (for example, 15/150 days, 18/180 days, etc.).

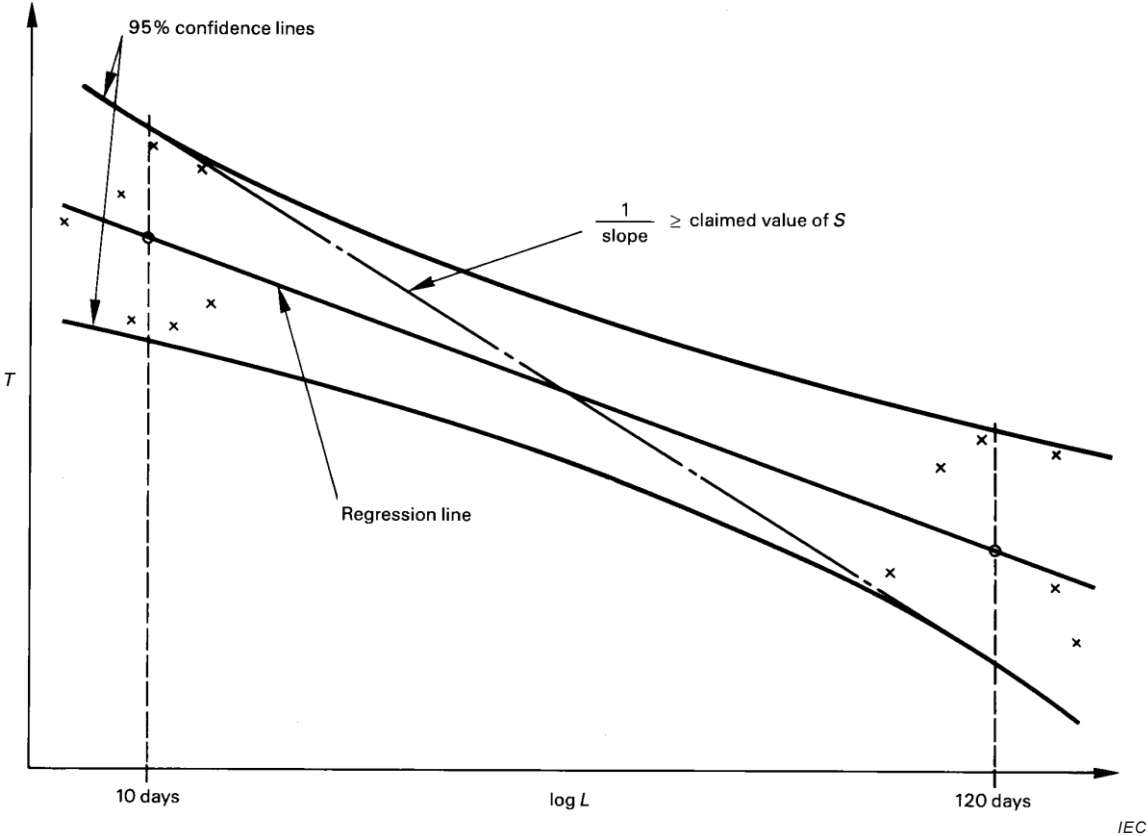

Figure E.1 – Assessment of claimed value of S

Annex F (normative)

Draught-proof enclosure

The following recommendations refer to the construction and use of a suitable draught-proof enclosure, as required for the test of lamp controlgear heating. Alternative constructions for draught-proof enclosures are permitted if it is established that similar results are obtained.

The draught-proof enclosure should be rectangular, with a double skin on top and on at least three sides, and with a solid base. The double skins should be of a perforated metal, spaced apart by approximately 150 mm, with regular perforations of 1 mm to 2 mm in diameter, occupying about 40 % of the whole area of each skin.

The internal surfaces should be painted with a matt paint. The three principal internal dimensions should each be at least 900 mm. There should be a clearance of at least 200 mm between the internal surfaces and the top and four sides of the largest lamp controlgear for which the enclosure is designed.

If it is required to test two or more sets of lamp controlgear in a large enclosure, care should be taken that radiation from one lamp controlgear cannot affect any other.

There should be a clearance of at least 300 mm above the top of the enclosure and around the perforated sides. The enclosure should be at a location protected, as far as possible, from draughts and sudden changes in air temperature. It should also be protected from sources of radiant heat.

Lamp controlgear under test should be positioned as far as possible from the five internal surfaces of the enclosure, the lamp controlgear with wooden blocks standing on the bottom of the enclosure, as required by Annex D.

Annex G (normative)

Explanation of the derivation of the values of pulse voltages

G.1 Pulse voltage rise time T

The pulse voltage rise time T is intended to shock-excite the input filter of the inverter and produce a "worst-case" effect. The time of 5 μs is chosen to be less than the rise time of a very poor input filter.

$$T = \pi \sqrt{LC} \quad (\text{G.1})$$

where

L is the input filter inductance;

C is the input filter capacitance.

G.2 Long-duration pulse voltages

The peak value for long-duration pulse voltages is given as two times the design voltage. See Figure G.2.

For 13 V and 26 V invertors, this gives a voltage applied to the inverter as follows:

$$(13 \times 2) + 15 = 41 \text{ and}$$

$$(26 \times 2) + 30 = 82.$$

NOTE Fifteen and 30 are the maximum values of the voltage ranges of 13 V and 26 V invertors respectively.

G.3 Short-duration pulse voltages

The peak value for short-duration pulse voltages is given as eight times the design voltage.

For 13 V and 26 V invertors this gives a voltage applied to the inverter as follows:

$$(13 \times 8) + 15 = 119 \text{ and}$$

$$(26 \times 8) + 30 = 238 .$$

NOTE Fifteen and 30 are the maximum values of the voltage ranges of 13 V and 26 V invertors respectively.

G.4 Measurement of short-duration pulse energy

Explanations referring to the choice of values for the components of the circuit for measuring short-duration pulse energy illustrated in Figure G.1.

The discharge shall be made aperiodic in order that the Zener diode receives one pulse only. Consequently, the resistance R shall be sufficiently large to ensure that:

- a) the influence of the self-inductance L of the circuit, due to the wiring, is sufficiently small; this implies that the time-constant L/R is definitely smaller than the time constant RC ;

- b) the maximum value of the current (which may be assessed by $(V_{pk} - V_Z)/R$) should be compatible with the good operation of the Zener diode.

On the other hand, this resistance R should not be too large if the pulse has to remain short-lived.

With a total inductance of 14 μH to 16 μH (as indicated in the text of Figure G.1) and the values for C indicated below, it appears that the previous conditions may be fulfilled with values of R of the order of magnitude of 20 Ω for an inverter whose design voltage is 13 V rising to about 200 Ω for a design voltage of 110 V.

It should be noted that it is not necessary to insert a separate inductance L in the circuit of Figure G.1.

Assuming an aperiodic discharge, the value of the capacity C is related to the energy E_Z applied to the Zener diode (which takes the place of the inverter) and to the voltages involved by the expression:

$$C = \frac{E_Z}{(V_{pk} - V_Z - V_{CT}) \times V_Z} \quad (\text{G.2})$$

where

V_{pk} is the peak voltage initially applied to capacitor C ;

V_Z is the voltage of the Zener diode;

V_{CT} is the final voltage on capacitor C_T .

Let us denote by

V_d the design voltage of the inverter to be tested;

V_{max} the maximum value of its rated voltage range (1,25 V_d);

one will choose

$V_Z = V_{max}$ (the best possible approximation);

$V_{pk} = 8 V_d + V_{max}$

and, moreover, V_{CT} will remain equal to or less than 1 V.

This last condition allows this voltage V_{CT} to be neglected with respect to the difference $(V_{pk} - V_Z)$ and one may thus write

$$C = \frac{E_Z}{(V_{pk} - V_Z) \times V_Z} \quad (\text{G.3})$$

With the values for the voltages indicated above and with the prescribed conditions $E_Z = 1 \text{ mJ}$, the expression of C becomes

$$C (\mu\text{F}) = \frac{125}{V_d \times V_{max}} \quad (\text{G.4})$$

On the other hand, a minimum value for the capacity C_T may be computed starting from

$$E_Z = C_T V_{CT} V_Z \quad (\text{G.5})$$

and, adopting 1 mJ for E_C and 1 V for V_{CT} , we are led to

$$C_T (\mu\text{F}) + \frac{1\,000}{V_{\text{max}}} \quad (\text{G.6})$$

Considering the case where $V_{\text{max}} = 1,25 V_d$, the values of capacities C and C_T may then be expressed as a function of the design voltage V_d as follows:

$$C (\mu\text{F}) + \frac{100}{(V_d)^2} \quad (\text{G.7})$$

and

$$C_T (\mu\text{F}) + \frac{800}{V_d} \quad (\text{G.8})$$

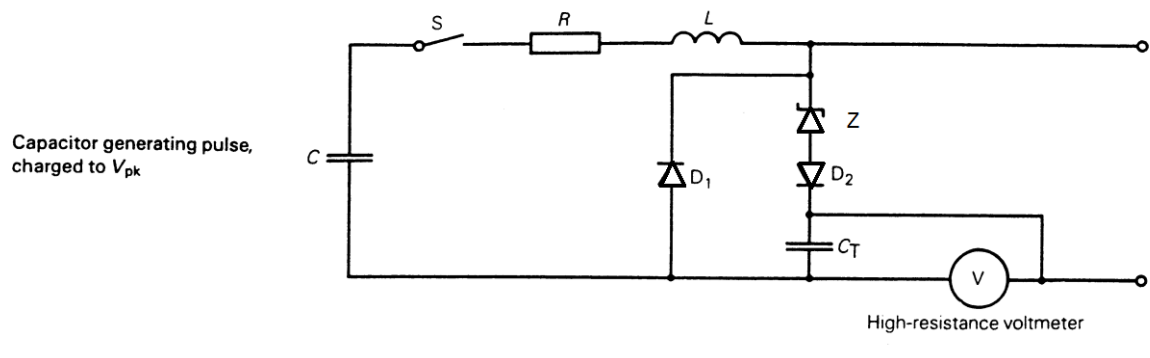

Key

- R resistance of the circuit (for the discussion on its value, see Annex G)
- L inductance representing the self-inductance of the circuit (it is thus not necessary to materialize it by a separate element in this measuring circuit)
- Z Zener diode whose voltage V_Z will be chosen as near as possible to the maximum value voltage range (V_{max})
- C capacitor initially charged to a voltage V_{pk} equal to eight times the design voltage of the inverter and intended to deliver an energy of 1 mJ into the diode Z^a
- C_T integration capacitor chosen so that after discharge, the voltage V on it is equal to or less than 1 V ^b
- D_1 reverse current by-pass diode, PIV rated 20 times design voltage, fast t_{on} and t_{off} 200 ns.
- D_2 reverse blocking diode, preferably fast switch off with t_{off} 200 ns.
- S ON/OFF switch, whose blade bounce time is longer than discharge time. Semiconductor switch may be used as an alternative.
- V voltmeter (normally electronic) with input resistance higher than 10 M Ω

Table G.1 refers to the most popular design voltages. It gives:

- 1) the values of capacities C and C_T resulting from the equations indicated above for the case where $V_{\text{max}} = 1,25 V_d$
- 2) the values of the resistance R securing the time constants L/R and RC the relation:

$$\frac{L}{R} = 0,05RC$$

when L is assumed to be 15 μH .

It should be noted that such resistances R limit the maximum current to the order of magnitude of 4,5 A.

3) the time constants RC which allow the order of magnitude of the pulse durations to be assessed.

^a As indicated in Annex G, the value of its capacity is given by

$$C (\mu\text{F}) = \frac{125}{V_d \times V_{\text{max}}} \text{ or } \left(\frac{100}{(V_d)^2} \text{ if } V_{\text{max}} = 1,25 V_d \right)$$

^b As indicated in Annex G, the minimal value of its capacity (corresponding to a voltage equal to 1 V) is given by

$$C_T (\mu\text{F}) = \frac{1\,000}{V_{\text{max}}} \text{ or } \left(\frac{800}{V_d} \text{ if } V_{\text{max}} = 1,25 V_d \right)$$

This capacitor shall be of a non-electrolytic type so that a voltage is not induced by the dielectric film before the initial charge.

Figure G.1 – Circuit for measuring short-duration pulse energy

Table G.1 – Component values for measurement of pulse energy

| Design voltage V | Capacitance C μF | Capacitance C_T μF | Resistance R Ω | Time constants RC μs |
|---------------------|--------------------------------|------------------------------------|--------------------------|------------------------------------|
| 13 | 0,59 | 61,5 | 22,5 | 13,3 |
| 26 | 0,15 | 30,8 | 45 | 6,7 |
| 50 | 0,04 | 16 | 87 | 3,5 |
| 110 | 0,008 3 | 7,3 | 190 | 1,6 |

As mentioned before, the values of C_T appearing in this table are minimum values. Larger capacities may be used provided that the reading of the voltage V on the voltmeter may still be made in good conditions. If V volts are read, the energy applied to the Zener diode will be given by the expression: $E_Z = C_T V_{CT} V_Z$

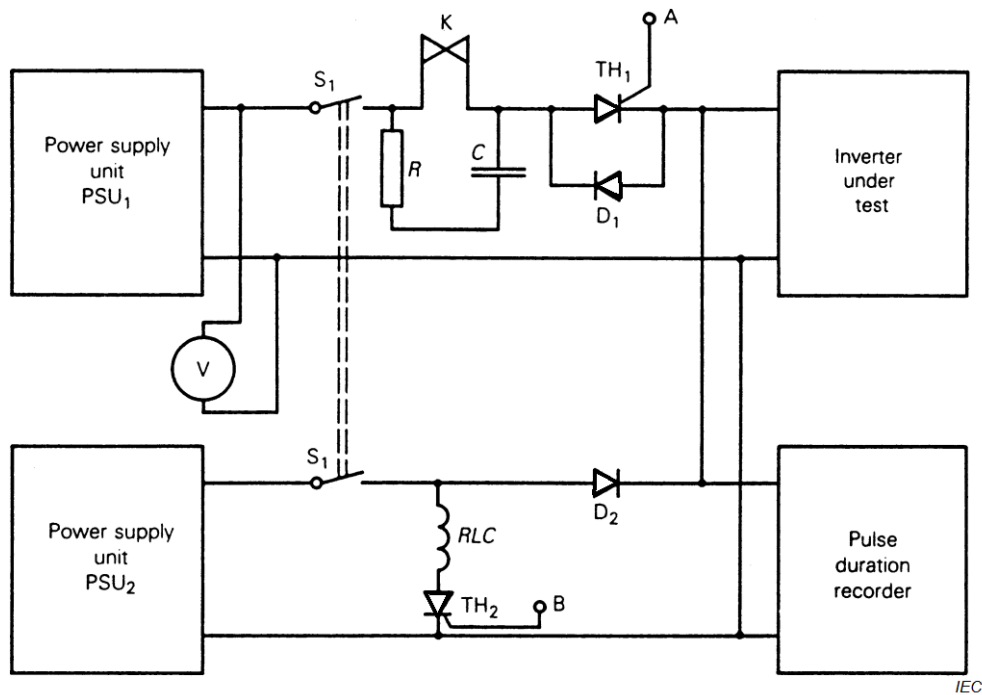

a) Example of a circuit for producing long-duration pulses

Key

PSU₁ power supply unit ^{a b}

PSU₂ power supply unit adjusted to maximum of input voltage range ^b

TH₁ main switching thyristor used to apply voltage pulse to the inverter ^c

TH₂ thyristor controlling the action of the relay RLC.

D₁ reverse current by-pass diode for TH₁ ^d

D₂ blocking diode for PSU₂.^e

RLC pulse termination relay with contacts K.

R and C spark suppression components. Suggested values are 100 Ω and 0,1 μF (for 26 V invertors).

S₁ switch used as ON/OFF or reset control.

^a Capable of supplying maximum pulse voltage required (maximum of nominal voltage range + *x* times design voltage) with pulse current demanded by inverter at this voltage with 2 % regulation (no load to full load)

^b Preferably both PSUs should be fitted with current limits to prevent damage in the event of the inverter under test breaking down.

^c Many common thyristors should be suitable for this job. They shall have a turn-on time of about 1 μs and adequate pulse current capability.

^d Allows initial oscillatory transients to operate. Shall be fast type (200 ns to 500 ns) with voltage rating equal to twice the maximum pulse voltage.

^e Prevents output impedance of PSU₂, loading voltage pulse source (PSU₁). Shall be fast type (approximately 1 μs turn off) with voltage rating equal to twice the maximum pulse voltage.

The delay system for securing the correct duration of the pulse is not represented on the Figure G.2 a). It shall ensure the triggering of thyristor TH₂ 500 ms after the action of TH₁, account being taken of the operating time of the relay (see Figure G.2 b))

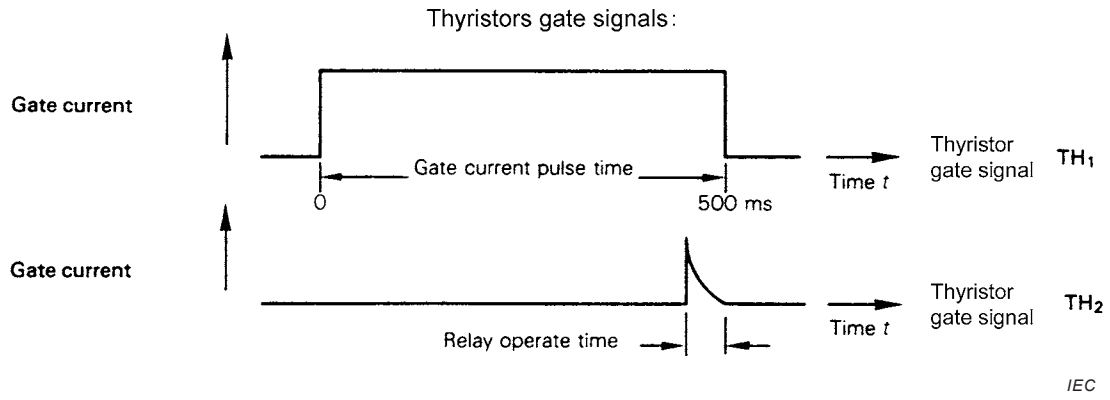

b) Time behaviour of the thyristors TH₁ and TH₂

Figure G.2 – Suitable circuit for producing and applying long-duration pulses

Annex H (normative)

Tests

H.1 Ambient temperature and test room

H.1.1 Measurements shall be made in a draught-free room and at an ambient temperature within the range of 20 °C to 27 °C.

For those tests which require constant lamp performance, the ambient temperature around the lamp shall be within the range of 23 °C to 27 °C and shall not vary by more than 1 °C during the test.

H.1.2 Apart from the ambient temperature, air circulation also influences the temperature of the lamp controlgear. For reliable results, the test room shall be free from draughts.

H.1.3 Before measuring the resistance of a winding in the cold state, the lamp controlgear shall be left in the test room for a sufficient time prior to the test to ensure that it reaches the ambient temperature of the test room.

There may be differences in the ambient temperatures before and after heating of the lamp controlgear. This is difficult to correct because the temperature of the lamp controlgear will lag behind the changed ambient temperature. An additional lamp controlgear of the type to be tested shall be installed in the test room and its cold resistance measured at the beginning and end of the temperature test. The difference in resistance can be used as a basis for correcting the readings of the lamp controlgear under test, using the equation for determining the temperature.

The above difficulties can be eliminated by carrying out the measurements in a temperature-stabilized room, for which no corrections are necessary.

H.2 Supply voltage and frequency

H.2.1 Test voltage and frequency

Unless otherwise specified, the controlgear to be tested shall be operated at its design voltage and the reference ballast at its rated voltage and frequency.

H.2.2 Stability of supply and frequency

Unless otherwise specified, the supply voltage, and, where appropriate for the reference ballasts, the frequency shall be maintained constant within $\pm 0,5$ %. However, during the actual measurement, the voltage shall be adjusted to within $\pm 0,2$ % of the specified testing value.

H.2.3 Supply voltage waveform for reference ballast only

The total harmonic content of the supply voltage shall not exceed 3 %, harmonic content being defined as the root-mean-square (r.m.s.) summation of the individual components using the fundamental as 100 %.

H.3 Electrical characteristics of lamps

The ambient temperature may affect the electrical characteristics of lamps (see Clause H.1). In addition, lamps show an initial spread of characteristics independent of the ambient temperature; furthermore, such characteristics may change during the lamp's life.

For measurement of lamp controlgear temperatures at 100 % and 110 % of rated supply voltage, it is sometimes possible (for example, for chokes used in starter-operated circuits), to eliminate the influence of the lamp by operating the lamp controlgear at a short-circuit current equal to the value obtained with a reference lamp at 100 % or 110 % of rated voltage. The lamp is short-circuited and the supply voltage adjusted so that the required current passes through the circuit.

In case of doubt, the measurement shall be made with a lamp. These lamps shall be selected in the same manner as reference lamps, but disregarding the narrow tolerances on lamp voltage and wattage as required for reference lamps.

When assigning the temperature rise of a lamp controlgear, the current flowing through the winding being measured shall be recorded.

H.4 Magnetic effects

Unless otherwise specified, no magnetic object shall be allowed within 25 mm of any face of the reference ballast or the lamp controlgear under test.

H.5 Mounting and connection of reference lamps

In order to ensure that the reference lamps repeat their electrical values with the greatest consistency, it is recommended that the lamps be mounted horizontally and be allowed to remain permanently in their test lampholders. As far as identification of lamp controlgear terminals will permit, reference lamps should be connected in circuit maintaining the polarity of the connections used during ageing.

H.6 Reference lamp stability

H.6.1 A lamp shall be brought to a condition of stable operation before carrying out measurements. No swirling shall be present.

H.6.2 The characteristics of a lamp shall be checked immediately before and after each series of tests.

H.7 Instrument characteristics

H.7.1 Potential circuits

Potential circuits of instruments connected across the lamp shall not pass more than 3 % of the nominal running current.

H.7.2 Current circuits

Current circuits of instruments connected in series with the lamp shall have a sufficiently low impedance such that the voltage drop shall not exceed 2 % of the objective lamp voltage. Where measuring instruments are inserted into parallel heating circuits, the total impedance of the instruments shall not exceed 0,5 Ω .

H.7.3 RMS measurements

Instruments shall be essentially free from errors due to waveform distortion and shall be suitable for the operating frequencies. Care shall be taken to ensure that the earth capacitance of instruments does not disturb the operation of the unit under test. It may be necessary to ensure that the measuring point of the circuit under test is at earth potential.

H.8 Inverter power sources

Where lamp controlgear are intended for use from battery supplies, it is permissible to substitute a d.c. power source other than a battery, provided that the source impedance is equivalent to that of a battery.

NOTE A non-inductive capacitor of appropriate rated voltage and with a capacitance of at least 50 μF , connected across the supply terminals of the units under test normally provides a source impedance simulating that of a battery.

H.9 Reference ballast

When measured in accordance with the requirements given in IEC 60921, reference ballasts shall have those characteristics specified both in that standard and on the appropriate lamp data sheets in IEC 60081 and IEC 60901.

H.10 Reference lamps

Reference lamps shall be measured and selected as outlined in IEC 60921 and have the characteristics specified on the appropriate lamp data sheet in IEC 60081 and IEC 60901.

H.11 Test conditions

H.11.1 Resistance measurement delays

Since the lamp controlgear may cool rapidly after switch-off, a minimum delay is recommended between switch-off and measurement of resistance. It is therefore recommended that the coil resistance be determined as a function of the elapsed time, from which the resistance at the moment of switch-off can be established.

H.11.2 Electrical resistance of contacts and leads

Connections shall be eliminated from the circuit wherever possible. If switches are used to switch from operating to test conditions, a regular check shall be made to verify that contact resistances in the switches remain sufficiently low not to affect the test results. Due account shall also be taken of the resistance of any connecting leads between the lamp controlgear and the resistance measuring instruments.

To ensure an improvement in measuring accuracy, it is recommended to apply the so-called four-point measurement with double wiring.

H.12 Lamp controlgear heating

H.12.1 Built-in lamp controlgear

H.12.1.1 Temperatures of lamp controlgear parts

The lamp controlgear shall be placed in an oven as detailed in Clause 13 for the thermal endurance test of windings.

The lamp controlgear shall function electrically in a manner similar to that in normal use at rated supply voltage, as detailed in H.12.4.

The oven thermostats are then regulated in such a way that the internal temperature of the oven attains a value such that the temperature of the hottest winding is approximately equal to the claimed value of t_w .

After 4 h, the actual temperature of the winding is determined by the "change-in-resistance" method (see Clause 13, Equation (1)) and, if the difference with the value t_w is more than ± 5 K, the oven thermostats are readjusted to approximate as closely as possible the t_w temperature.

After thermal stability has been obtained, winding temperatures are measured, if possible by the "change-in-resistance" method (see Clause 13, Equation (1)) and, in other cases, by means of a thermocouple or the like.

After measuring the winding temperature of the lamp controlgear at supply voltage of 100 % of the rated voltage, the supply voltage is increased to 106 % of rated voltage. After thermal stability has been obtained, the temperatures of lamp controlgear parts shall comply with the requirements indicated in the relevant Part 2 of IEC 61347.

H.12.1.2 Temperature of lamp controlgear windings

For lamp controlgear for which a temperature rise of the windings under normal conditions is claimed, the test arrangement is as follows:

The lamp controlgear shall be placed in a draught-proof enclosure as detailed in Annex F, the lamp controlgear being supported by two wooden blocks as shown in Figure H.1.

The wooden blocks shall be 75 mm high, 10 mm thick and of a width equal to, or greater than, the width of the lamp controlgear. Furthermore, the blocks shall be positioned with the extreme end of the lamp controlgear aligned with the outer vertical sides of the block.

Where the lamp controlgear consists of more than one unit, each unit may be tested on separate blocks. Capacitors, unless enclosed with the lamp controlgear case, shall not be placed in the draught-proof enclosure.

The lamp controlgear shall be tested under normal conditions at rated supply voltage and frequency until steady temperatures are obtained.

Winding temperatures are measured, if possible by the "change-in-resistance" method (see Clause 13, Equation (1)).

H.12.2 Independent lamp controlgear

The lamp controlgear shall be placed in a draught-proof enclosure as detailed in Annex F, the lamp controlgear being mounted in a test corner consisting of three dull-black painted boards 15 mm to 20 mm thick and arranged so as to imitate two walls and the ceiling of a room. The lamp controlgear is secured to the ceiling of the test corner as close as possible to the walls, the ceiling extending at least 250 mm beyond the other sides of the lamp controlgear.

Other test conditions are the same as specified for luminaires in IEC 60598-1.

H.12.3 Integral lamp controlgear

Integral lamp controlgear are not separately tested for limitation of lamp controlgear heating because they are tested as part of the luminaire in accordance with IEC 60598-1.

H.12.4 Test conditions

For the test under normal conditions, where lamp controlgear are operated with appropriate lamps, these shall be placed in such a way that the heat generated does not contribute to the heating of the lamp controlgear.

Lamps to be used for the limitation of lamp controlgear heating tests shall be deemed to be appropriate if, when associated with a reference ballast and operating in an ambient temperature of 25 °C, the lamp's running current does not deviate by more than 2,5 % from the corresponding objective values given in the relevant IEC lamp standard, or declared by the manufacturer for those lamps not yet standardized.

It is permitted, at the manufacturer's discretion, for reactor type lamp controlgear (simple choke impedance in series with the lamp), that the test and measurement be made without a lamp provided that the current is adjusted to the same value as found with the lamp at rated supply voltage.

With a non-reactor type lamp controlgear, it is necessary to ensure that representative losses are obtained.

For starterless lamp controlgear with transformer parallel cathode heating, and where IEC 60081 and IEC 60901 show that lamps of the same rating are available with either low or high resistance cathodes, the tests shall be carried out using lamps having low resistance cathodes.

Dimensions in millimetres

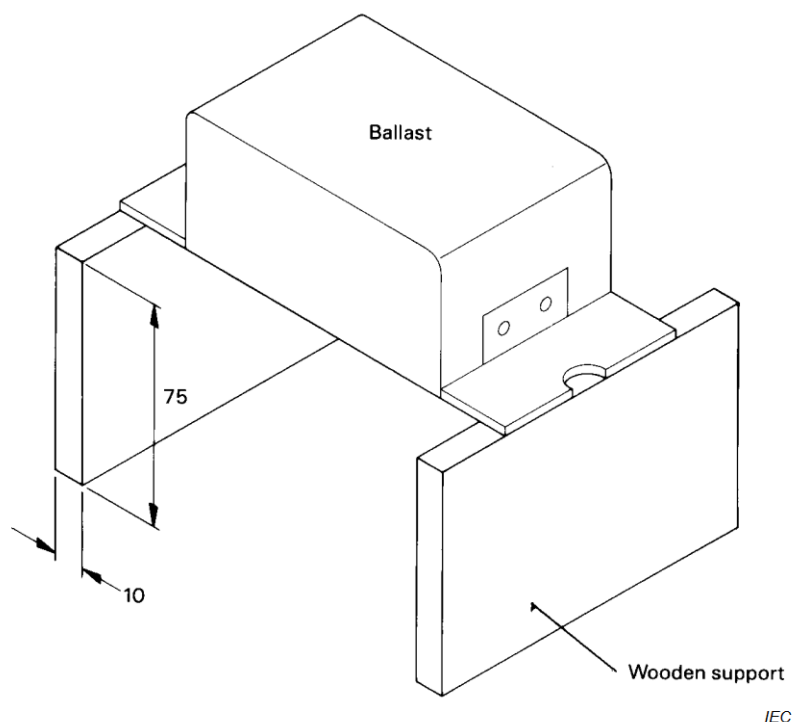

(±1,0 mm tolerance on dimensions)

Figure H.1 – Test arrangement for heating test

Annex I (normative)

Additional requirements for built-in magnetic ballasts with double or reinforced insulation

I.1 General

This annex applies to magnetic ballasts for building-in having double or reinforced insulation.

I.2 Terms and definitions

For the purposes of this annex, the following terms and definitions apply.

I.2.1

built-in ballast with double or reinforced insulation

ballast in which accessible metallic parts are insulated from live parts by double or reinforced insulation

I.2.4

basic insulation

insulation applied to live parts to provide basic protection against electric shock

I.2.5

supplementary insulation

independent insulation applied in addition to basic insulation in order to provide protection against electric shock in the event of a failure of basic insulation

I.2.6

double insulation

insulation comprising both basic insulation and supplementary insulation

I.2.7

reinforced insulation

single insulation system applied to live parts, which provides a degree of protection against electric shock equivalent to double insulation

Note 1 to entry: The term “insulation system” does not imply that the insulation shall be one homogeneous piece. It may comprise several layers, which cannot be tested singly as supplementary or basic insulation.

I.3 General requirements

Ballasts with double or reinforced insulation shall be provided with a thermal protector which cannot be bridged or removed without the means of a tool; moreover, any failure of the protection device shall result in an open circuit condition only.

This should be declared by the manufacturer of the protector.

Use of a non-resetting device is accepted.

Ballasts with double or reinforced insulation shall also comply with Annex B of this standard but the turns to be short circuited shall be those located as far possible from the thermal protector.

Moreover, at the end of the tests, the ballasts shall comply in addition to Clause I.10 but with the values of the dielectric strength test voltages reduced to 35 % of the value requested in Table 3 and the insulation resistance shall not be less than 4 M Ω .

I.4 General notes on tests

Clause 5 applies.

I.5 Classification

Clause 6 applies

I.6 Marking

In addition to the markings mentioned under 7.1 of this standard, ballasts with double or reinforced insulation shall be identified by the symbol:



[SOURCE: IEC 60417-6295 (2014-09)]

The meaning of this marking should be explained in the manufacturer's literature or catalogue.

I.7 Protection against accidental contact with live parts

In addition to the requirements of Clause 10 of this standard, it shall not be possible for the test finger to make contact with metal parts protected by basic insulation only.

This requirement does not necessarily imply that the live parts shall be isolated from the test finger by double or reinforced insulation.

I.8 Terminals

Clause 8 applies.

I.9 Provision for earthing

In addition, ballasts with double or reinforced insulation shall have no protective earthing terminal.

I.10 Moisture resistance and insulation

Clause 11 applies.

I.11 High-voltage impulse test

Clause 15 of IEC 61347-2-9:2012 applies for HID ballasts.

I.12 Thermal endurance test for windings of ballasts

The thermal endurance test is carried out according to Clause 13.

Devices for limiting the temperature shall be bridged before the thermal endurance test. Specially prepared samples may be necessary.

After the test, when the ballasts have returned to ambient temperature, they shall satisfy the following requirements.

- a) At rated voltage, at least six ballasts out of seven shall start the same lamp and the lamp arc current shall not exceed 115 % of the value measured before the test, as described above.

This test is to determine any adverse change in ballast setting.

- b) For all ballasts, the insulation resistance between the winding and the ballast case, measured at approximately 500 V d.c., shall be not less than 4 M Ω .
- c) All ballasts shall withstand a dielectric strength test between the winding and the ballast case, for 1 min, with the appropriate values of Table 3 reduced to 35 %.

I.13 Ballast heating

Clause 14 of IEC 61347-2-9:2012 applies.

I.14 Screws, current-carrying parts and connections

Clause 17 applies.

I.15 Creepage distances and clearances

Clause 16 applies with the following addition: For built-in ballasts, provided with double or reinforced insulation, the corresponding values given for luminaires in IEC 60598-1:2014 apply.

For cases where a higher impulse withstand category is required, see Annex V of IEC 60598-1:2014.

I.16 Resistance to heat and fire

Clause 18 applies.

I.17 Resistance to corrosion

Clause 19 applies.

Annex J
(normative)

Schedule of more onerous requirements

This annex applies to amended clauses containing more serious/critical requirements which require products to be retested.

NOTE Clauses marked 'R' and scheduled in this annex will be included in future amendments/editions.

Annex K (informative)

Conformity testing during manufacture

K.1 General

The tests specified in this annex should be carried out by the manufacturer on each control gear after production and are intended to reveal, as far as safety is concerned, unacceptable variations in material and manufacture. These tests are intended not to impair the properties and the reliability of the control gear and they may vary from certain type tests in the standard by lower voltages used.

More tests may have to be conducted to ensure that every control gear conforms with the sample approved under the type test to this specification. The manufacturer should determine these tests from his experience.

Within the framework of the quality manual, the manufacturer may vary this test procedure and its values to one better suited to his production arrangements and may make certain tests at an appropriate stage during manufacture, provided it can be proved that at least the same degree of safety is ensured as specified in this annex.

K.2 Testing

Electrical tests should be conducted on 100 % of all units produced as scheduled in Table K.1. Failed products are to be quarantined for scrap or re-working.

Table K.1 – Minimum values for electrical tests

| Test | Type of control gear and compliance | | | | Ignitor |
|--------------------------------------------------------------------------------------------------------------------------------------------------------------------------------------------------------------------------------------------------------------------------------------------------|--------------------------------------------------------------------------------------------------------------------------------------------------|---------------------------------------------------------------------------------------------------------------------------------------------------------------|---------------------------------------------------------------------------------------------------------------------------------------------------------------------------------------------------------------------------------------------------------|------------------------------------------------------------------------------------------------------------------------------------------------------------------------------------------|--------------------------------------------------------------------------------------------------------------------------------------------------|
| | Magnetic ballast | A.C. and d.c. electronic ballast | Step down converter for low voltage filament lamps and LED module | Inverter and converter for high frequency cold start lamps | |
| Visual inspection ^a | Applicable | | | | |
| Function test/circuit continuity (with lamp or simulation lamp) | Impedance test ^b | Lamp / operating voltage | Lamp / operating voltage | Lamp / operating voltage | At 90% minimum rated supply voltage: peak voltage |
| Earth continuity ^c Applied between earthing terminal on control gear and accessible parts likely to become live (only for class I independent control gear) | Maximum resistance 0,50 Ω, measured by passing a minimum current of 10 A with a no-load voltage not exceeding 12 V for at least 1 s. | Maximum resistance 0,50 Ω, measured by passing a minimum current of 10 A with a no-load voltage not exceeding 12 V for at least 1 s. | Maximum resistance 0,50 Ω, measured by passing a minimum current of 10 A with a no-load voltage not exceeding 12 V for at least 1 s. | Maximum resistance 0,50 Ω, measured by passing a minimum current of 10 A with a no-load voltage not exceeding 12 V for at least 1 s. | Maximum resistance 0,50 Ω, measured by passing a minimum current of 10 A with a no-load voltage not exceeding 12 V for at least 1 s. |
| Electric strength ^c | Measured by applying a minimum voltage of 1,5 kV a.c. for a minimum of 1 s or 1,5 √2 kV d.c. Made between terminals short-circuited and body. | Measured by applying a minimum voltage of 1,5 kV a.c. for a minimum of 1 s or 1,5 √2 kV d.c. Made between input/output terminals short-circuited and body. | Measured by applying a minimum voltage of: – between input/output terminals short-circuited and body 1,5 kV a.c. or 1,5 √2 kV d.c. for a minimum of 1 s – between input and output terminals 3 kV a.c. or 3 √2 kV d.c. for a minimum of 1 s | Measured by applying a minimum voltage of 1,5 kV a.c. for a minimum of 1 s or 1,5 √2 kV d.c. Made between: – input/output terminals short-circuited and body – input and output | Measured by applying a minimum voltage of 1,5 kV a.c. for a minimum of 1 s or 1,5 √2 kV d.c. Made between terminals short-circuited and body. |
| ^a Visual inspection: visual inspection should ensure that the control gear is fully assembled and free from sharp edges etc. which may cause damage or injuries. It should also ensure that any labels are legible and properly attached and any printing legible. | | | | | |
| ^b Impedance test: the impedance test is carried out by measuring the ballast voltage when the ballast has been loaded with its rated current; alternatively, it may be carried out at a fixed voltage (defined by the appropriate lamp data sheet) and measuring the ballast current. | | | | | |
| ^c Class II (independent) control gear or control gear with plastic case and without earthing terminal: the earth continuity, the electrical strength and the insulation resistance tests do not apply. | | | | | |

K.3 Additional dielectric strength tests for controlgear with protection against pollution by the use of coating or potting material

100 % of manufactured lamp controlgear with protection against pollution by the use of coating or potting material should be subjected to an electric strength tests according to Clause 12 with the following modification.

Initially, not more than half of the prescribed test voltage is applied, then it is raised with a steepness not exceeding 1 560 V/ms to the full value which is held for 1 s.

The tripping current should not exceed 100 mA.

NOTE Tripping of the current sensing device is regarded as a flashover or breakdown.

Annex L (normative)

Particular additional requirements for controlgears providing SELV

L.1 General

This annex applies to controlgears for use as SELV supply for luminaires. It consists of the relevant requirements of IEC 61558-1:2005 according to 4.2 of that standard, for associated transformers and IEC 61558-2-6 for safety isolating transformers. In addition, for controlgears containing HF-transformers, relevant requirements of IEC 61558-2-16 also apply.

L.2 Terms and definitions

For the purposes of this annex, the following terms and definitions apply.

L.2.1

short-circuit proof controlgear

controlgear not exceeding the specified temperature limits when overloaded or short-circuited, and which continues to meet all requirements of this standard after removal of the overload or short-circuit

L.2.2

non-inherently short-circuit proof controlgear

short-circuit proof controlgear equipped with a protective device which opens the input circuit or the output circuit, or reduces the current in the input circuit or the output circuit when the controlgear is overloaded or short-circuited and which continues to meet all requirements of this standard after the removal of the overload or short circuit and, if possible, after resetting or replacing of the protective device

Note 1 to entry: Examples of protective devices are fuses, overload releases, thermal fuses, thermal links, thermal cut-outs and PTC resistors, automatic break-off mechanical devices and fuses as printed circuits or printed circuit boards.

Note 2 to entry: In case of protection by a device which can neither be replaced nor reset, the wording "continue to meet all requirements of this standard after removal of the overload" does not imply that the controlgear continues to operate.

L.2.3

inherently short-circuit proof controlgear

short-circuit proof controlgear not equipped by construction with a device to protect the controlgear and in case of overload or short circuit, , does not exceed the specified temperature limits and continues to operate and meet all the requirements of this standard after the removal of the overload or short circuit

L.2.4

fail-safe controlgear

controlgear which, under abnormal conditions, permanently fails to function by the interruption of the input circuit but presents no danger to the user or surroundings

Note 1 to entry: Any non-resetting and non-replaceable protective device may be used.

L.2.5

non short-circuit proof controlgear

controlgears intended to be protected against excessive temperature by means of a protective device not provided with the controlgear, and which continues to meet all the requirements of this standard after the removal of the overload or short circuit and resetting of the protective device

L.2.6**separating HF transformer**

component part of the controlgear for which the rated frequency is much higher than the supply frequency

Note 1 to entry: This HF-transformer can be the separation between the input and output circuit(s) in the controlgear.

L.3 Classification

Controlgears are classified as follows.

a) According to their protection against electric shock

Independent controlgears are classified as follows:

- Class I controlgears;
- Class II controlgears;
- Class III controlgears.

b) According to the short-circuit protection or protection against abnormal use





Controlgears are classified as follows:

- non-inherently short-circuit proof controlgear;
- inherently short-circuit proof controlgear;
- fail-safe controlgear;
- non-short-circuit proof controlgear.

L.4 Marking

When symbols are used, they shall be as follows (see Table L.1):

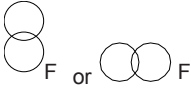
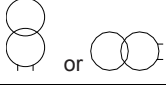
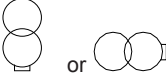
Table L.1 – Symbols for marking if marking is used

| | |
|------------------------------------------------------------------------------------|--------------------------------------------------------------------------------------------------------|
| PRI | Input |
| SEC | Output |
| === | Direct current [SOURCE: IEC 60417-5031(2002-10)] |
| N | Neutral |
| ~ | Single phase |
|  | Fuse link (add symbol for time-current characteristic) [SOURCE: IEC 60417-5016 (2002-10)] |
| t_a | Rated maximum ambient temperature |
|  | Frame or core terminal [SOURCE: IEC 60417-5020(2002-10)] |
|  | Fail-safe lamp controlgear [SOURCE: IEC 60417-5156 (2003-08)] |
|  | Non-short-circuit proof lamp controlgear [SOURCE: IEC 60417-5223 (2002-10)] |
|  | Short-circuit proof lamp controlgear (inherently or non-inherently) [SOURCE: IEC 60417-5220 (2002-10)] |
|  | Safety isolating lamp controlgear (SELV lamp controlgear) [SOURCE: IEC 60417-5222 (2002-10)] |

L.5 Protection against electric shock

Controlgears providing SELV shall, in addition to the requirements given in 10.3 and 10.4, comply with relevant requirements specified in 9.2 of IEC 61558-1:2005.

Compliance is checked by the test described in 9.2 of IEC 61558-1:2005.

L.6 Heating

Controlgear providing SELV and their supports or mounting surfaces shall not attain excessive temperature in normal use.

Compliance is checked by the relevant tests of Clause 14 of IEC 61558-1:2005, but with the following adjustments.

- In 14.1, 10th paragraph:
replace 10 % by 6 %;
- Replace Table 1 by the following Table L.2:

Table L.2 – Values of temperatures in normal use

| Parts | Temperature °C |
|------------------------------------------------------------------------------------------------------------------------------------------------------------------------------------------------------------------------------------------------------------------------------------------------------------------------------------------------------------------------------------------------------------------------------------------------------------------------------------------------------------------------------------------------------------------|-------------------|
| Case of capacitor | |
| – if t_c is marked | t_c^c |
| – if t_c is not marked | 50 |
| Windings (with bobbins and laminations have contact), if the winding insulation is | |
| – of class A material ^a | 100 |
| – of class E material | 115 |
| – of class B material | 120 |
| – of class F material | 140 |
| – of class H material | 165 |
| – of other material ^b | – |
| ^a The material classification is in accordance with IEC 60085 or IEC 60317-0-1 or equivalent standard. ^b If material other than those specified in IEC 60085:2007 under Class A, E, B, F and H are used, they shall withstand the tests of 14.3 in IEC 61558-1:2005. ^c The maximum temperature of capacitor, bridging the separation transformer, shall be lower than 50 °C if t_c is not marked, in case t_c is marked, the maximum temperature is t_c . For other components, see Table 12.1 of IEC 60598-1:2014. | |

- In 14.1, second paragraph from the end:
replace the reference to "18.3" by "L.8.3" of this annex.
- In 14.3, first paragraph:
replace the references to "14.2, 19.12.3 and 26.3" by "Clause L.6" of this annex, and
- In 14.3.4, first paragraph:
replace the references to "18.1, 18.2, 18.3" and "18.4" by "Clause L.8" of this annex.

For moulded-in transformers specially prepared, samples provided with thermocouples shall be submitted for testing.

L.7 Short-circuit and overload protection

Controlgears providing SELV shall not become unsafe due to short-circuits and overloads which may occur in normal use.

Compliance is checked by the relevant tests of Clause 15 of IEC 61558-1:2005, but with the following adjustments:

- In 15.1, second paragraph:
replace the reference to "14.1" by "Clause L.6" of this annex.
- In 15.1, second paragraph after Table 3:
replace the reference to "Clause 9" by "Clause 10" of this standard.
- In 15.1, third paragraph after Table 3:
replace the reference to "18.3" by "L.8.3" of this annex.
- 15.3.4 is not applicable.
- In 15.5.1, third paragraph:
replace the references to "14.1" by " Clause L.6" of this annex.

L.8 Insulation resistance and electric strength

L.8.1 General

The insulation resistance and the electric strength of controlgears providing SELV shall be adequate.

Compliance is checked by the tests of Clauses 11 and 12 and Subclauses L.8.2 and L.8.3, which are made immediately after the test of Clause 11 in the humidity or in the room in which the specimen was brought to the prescribed temperature, after reassembly of those parts which may have been removed.

L.8.2 Insulation resistance

Insulation resistance is measured with a d.c. voltage of approximately 500 V applied, the measurement being made 1 min after application of the voltage.

The insulation resistance shall be not less than that shown in Table L.3.

Table L.3 – Values of insulation resistances

| Insulation to be tested | Insulation resistance MΩ |
|---------------------------------------------------------------------------------------------------------------------|-----------------------------|
| Between input circuits and output circuits | 5 |
| Between metal part of class II convertors which are separated from live parts by basic insulation only and the body | 5 |
| Between metal foil in contact with the inner and outer surfaces of enclosures of insulating material | 2 |

L.8.3 Electric strength

Immediately after the test of L.8.2, the insulation is subjected for 1 min to a voltage of substantially sine-wave form at rated mains frequency. The value of the test voltage and the points of application are given in Table L.4.

NOTE In Annex M, test voltages are given for controlgear intended to be used in luminaires where a higher availability is called by one of the Parts 2 of the IEC 60598 series.

Table L.4 – Table of dielectric strength test voltages for controlgears intended for use in impulse withstand Category II

| Application of dielectric strength test voltage ^b | Working voltage V ^a | | | | |
|--------------------------------------------------------------------------------------------------------------------------------------------------------------------------------------------------------------------------------------------------------------------------------------------------------------------------------------------------------------------------------------------------------------------------------------------------------------------------------------------------------------------------------------------------------------------------------------------------------------------------------------------------------------------------------------------------------------------------------------------------------------------|-----------------------------------|-------|----------------|-------|-------|
| | < 50 | ≤ 150 | > 150 ≤ 300 | 600 | 1 000 |
| 1) Between live parts of input circuits and live parts of output circuits (double or reinforced insulation) | 500 | 2 000 | 3 000 | 4 200 | 5 000 |
| 2) Over basic or supplementary insulation between: <ul style="list-style-type: none"> a) live parts having different polarity as in normal use, i.e. not under fault condition. Test not applicable within the same winding; b) live parts and the body, if intended to be connected to protective earth; c) accessible conductive parts and a metal rod of the same diameter as the flexible cable or cord (or metallic foil wrapped round the cord) inserted inside inlet bushing, cord guards and anchorage, and the like; d) live parts and an intermediate conductive part; e) intermediate conductive parts and the body; f) each input circuit and all other input circuits connected together. | 250 | 1 000 | 1 500 | 2 100 | 2 500 |
| 3) Over reinforced insulation between the body and live parts | 500 | 2 000 | 3 000 | 4 200 | 5 000 |
| <p>^a Values of dielectric strength test voltage for intermediate values of working voltage are found by interpolation between tabulated values, except for the span 150 V to 300 V.</p> <p>^b For the construction according to 19.12.3 b) and 26.2.4.1 of IEC 61558-1:2005 test b), the voltage is multiplied by the factor of 1,25. For the construction according to 26.2.4.2 of IEC 61558-1:2005, the voltage is multiplied by the factor 1,35.</p> | | | | | |

L.9 Construction

The construction of transformers used in controlgears providing SELV shall be such that they comply with all relevant parts specified in 19.12 of IEC 61558-1:2005, and Clause 19 of IEC 61558-2-6:2009 with the exception of 19.1.6 for controlgears other than independent.

If, however, insulated winding wires are used for controlgear with an input voltage of up to 300 V, the dielectric strength test voltage is limited to 3 kV for raw material.

In addition, for separating HF transformers, the relevant requirements of Clause 19 of IEC 61558-2-16:2009 apply with the exceptions for separating HF transformers other than independent given in 19.1.3.7 of IEC 61558-2-16:2009.

Compliance is checked by inspection and measurement.

L.10 Components

Components used as protective devices in controlgears providing SELV shall comply with relevant requirements given in 20.6, 20.7, 20.8, 20.9, 20.10 and 20.11 of IEC 61558-1:2005.

Compliance is checked by inspection and the relevant test described in IEC 61558-1.

L.11 Creepage distances, clearances and distances through insulation

Creepage distances and clearances shall be not less than the values shown in Clause 16. For distances through insulation Table L.5 shall apply. In addition transformers which form an integral part or used in a controlgear providing SELV shall comply with relevant requirements and tests given in Clause 26 of IEC 61558-1:2005 (pollution degree P3 is not required for lamp controlgear).

Distances through insulation within opto-couplers complying with the requirements for double or reinforced insulation according to IEC 60950-1, are not measured, if the individual insulation is adequately sealed and if air is excluded between individual layers of the material. Otherwise, the distance through insulation between the input and output of the opto-coupler shall be at least 0,4 mm. In both cases the tests according to Clause L.8 shall apply.

NOTE Further information regarding creepage distance, clearances and distances through insulation can be found in Annexes A, C, D, M, N and P of IEC 61558-1:2005.

Table L.5 – Distances through insulation (DTI) for the impulse withstand category II / material group IIIa (175 CTI < 400)

Pollution degree 2; dimensions in millimetres

| Distance through insulation | Measurement | | Working voltages ^{a c} V | | | |
|------------------------------------------------------------------------|-------------------------------------|-----------------------------------|-----------------------------------------|------------------------------------------|------------------------------------------|------------------------------------------|
| | Through winding enamel ^b | Other than through winding enamel | > 25 to < 50 | 100 | 150 | 250 |
| 1) Basic ^f | X | X | No requirement of thickness | | | |
| 2) Supplementary ^f | X | X | 0,1 ^d [0,05] ^e | 0,15 ^d [0,05] ^e | 0,25 ^d [0,08] ^e | 0,42 ^d [0,13] ^e |
| 3) Reinforced (excluding insulation between input and output circuits) | X | X | 0,2 ^d [0,1] ^e | 0,3 ^d [0,1] ^e | 0,5 ^d [0,15] ^e | 0,83 ^d [0,25] ^e |

NOTE The values of this table applicable to impulse withstand category III are given in Annex T, Table T.3.

^a For working voltages exceeding 250 V, see IEC 61558-1.

^b Measurement through winding wire enamel if at least one winding is constructed with wire complying with at least Grade 1 of IEC 60317-0-1.

^c Values of distances through insulation may be found for intermediate values of working voltages by interpolation between the values in the table. No values are required for working voltages below 25 V as the voltage test of Table L.3 is considered sufficient.

^d For solid insulation.

^e In case of insulation consisting of thin sheets.

^f When double insulation is required between input and output windings, the total thickness through insulation shall be the same as shown in row 3) whether measured directly or via metals parts, with the exception of insulated wires (see 19.12 of IEC 61558-1:2005).

Annex M (informative)

Dielectric strength test voltages for controlgear intended for the use in impulse withstand Category III

Table M.1 is intended to be used in cases where a controlgear is designed for the impulse withstand Category III for use in luminaires where a higher availability is called for by one of the Parts 2 of the IEC 60598 series.

NOTE For further information, see Annex U of IEC 60598-1:2014.

**Table M.1 – Table of dielectric strength test voltages for controlgears
intended for use in impulse withstand Category III**

| Application of dielectric strength test voltage ^a | Working voltage ^b V | | | | |
|-----------------------------------------------------------------------------------------------------------------------------------------------------------------------------------------------------------------------------------------------------------------------------------------------------------------------------------------------------------------------------------------------------------------------------------------------------------------------------------------------------------------------------------------------------------------------------------------------------------------------------------------------------------------------------------------------|-----------------------------------|-------|----------------|-------|-------|
| | < 50 | ≤ 150 | > 150 ≤ 300 | 600 | 1 000 |
| 1) Between live parts of input circuits and live parts of output circuits (double or reinforced insulation) | 500 | 2 800 | 4 200 | 5 000 | 5 500 |
| 2) Over basic or supplementary insulation between: <ul style="list-style-type: none"> i. live parts of different polarity; test not applicable within the same winding; ii. live parts and the body if intended to be connected to protective earth; iii. accessible conductive parts and a metal rod of the same diameter as the flexible cable or cord (or metallic foil wrapped round the cord) inserted inside inlet bushing, cord guards and anchorage, and the like; iv. live parts and an intermediate conductive part; v. intermediate conductive parts and the body; vi. live parts and an intermediate conductive part. | 250 | 1 400 | 2 100 | 2 500 | 2 700 |
| 3) Over-reinforced insulation between the body and live parts | 500 | 2 800 | 4 200 | 5 000 | 5 500 |
| ^a Values of dielectric strength test voltage for intermediate values of working voltage are found by interpolation between tabulated values. | | | | | |
| ^b For the construction according to 19.12.3 b) and 26.2.4.1 test b) of IEC 61558-1:2005, the voltage is multiplied by the factor 1,25. For the construction according to 26.2.4.2 of IEC 61558-1:2005, the voltage is multiplied by the factor 1,35. | | | | | |

For the performance of the test, the requirements given in 18.3 of IEC 61558-1:2005 apply.

Annex N (normative)

Requirements for insulation materials used for double or reinforced insulation

N.1 General

This annex applies to solid or thin sheets insulating materials used to fulfil the requirements for double or reinforced insulation.

This annex is not applicable to insulated winding wires and insulating cover or envelope of a controlgear.

N.2 Reference document

Clause 2 of IEC 61347-1 applies.

N.3 Terms and definitions

For the purposes of this annex, the following terms and definitions apply.

N.3.1

solid insulation

insulation made of one layer of homogeneous material, interposed between two conductive parts

N.3.2

thin sheet insulation

insulation constructed of thin sheets (two or more) of insulating materials, interposed between two conductive parts

N.4 General requirements

N.4.1 Material requirements

The insulation material shall comply with IEC 60085 and the IEC 60216 series.

N.4.2 Solid insulation

The adequacy of solid insulation is verified by the electric strength test (Clause 12) of at least 5 kV or the applicable test voltage specified in Table N.1 multiplied by 1,35, whichever is the greater.

If the materials are not classified according to IEC 60085 and the IEC 60216 series, the value of the electric strength test is increased by further 10 % of the value specified: 5,5 kV or the applicable test voltage specified in Table N.1 multiplied by 1,5 whichever is the greater.

N.4.3 Thin sheet insulation

N.4.3.1 Thickness and composition of thin sheet insulation

The following list defines the requirements for thin sheet layers.

- Insulation in thin sheet material is permitted, irrespective of its thickness, provided that it is used inside the ballast and it is not subject to handling or abrasion during the production of the ballast and during maintenance.
- There is no requirement for all layers of insulation to be of the same material.
- Resin-impregnated coatings are not considered to be insulation in thin sheet material.
- For insulation constructed of thin sheets of insulated material, the insulation shall be such that, at every place, there is at least the required number of layers:
 - if the layers are non-separable (glued together):
 - 3 layers are required;
 - the entire composite sheet shall fulfil the mandrel test (pull force of 150 N)
 - if the layers are separated:
 - 2 layers are required;
 - each layer shall fulfil the mandrel test (pull force of 50 N)
 - if the layers are separated (alternative):
 - at least 3 layers are required;
 - 2/3 of the number of layers shall fulfil the mandrel test (pull force of 100 N).

N.4.3.2 Mandrel test (electric strength test during mechanical stress)

Three separate test specimens of thin sheets 70 mm in width shall be supplied by the manufacturer.

The test shall be performed by fixing the specimens of thin sheets on a mandrel made of nickel plated steel or brass with smooth surface finish as shown in Figure N.1.

A metal foil (aluminium or copper) $0,035 \text{ mm} \pm 0,005 \text{ mm}$ thick shall be placed closely to the surface of the specimen and subjected to a pull force of 1 N. The metal foil shall be so positioned that its borders are 20 mm away from the borders of the specimen, and when the mandrel is in its final position, it covers the edges upon which the specimen is lying by at least 10 mm.

The specimen is held in place at its free end by an appropriate clamping device and subjected to:

- a pull force of 150 N for a specimen consisting of several non-separable layers;
- a pull force of 100 N for a specimen consisting of 2/3 the number of separated layers (serrated or not); and
- a pull force of 50 N for a specimen consisting of a single layer.

The mandrel shall be slowly rotated forwards and backwards three times for 230° without a jerking motion. If the specimen breaks at the clamping device during the rotation, the test shall be repeated. If one or more specimens break at any other place, the test is not fulfilled. While the mandrel is in its final position, within a minute following the final positioning, a dielectric strength test voltage shall be applied for 1 min, as described in Clause 12, between the mandrel and the metal foil as follows:

- a test voltage of at least 5 kV or the applicable test voltage hereunder specified multiplied by 1,35, whichever is the greater, for a specimen consisting of several non-separable layers (at least 3 layers);
- a test voltage of at least 5 kV or the applicable test voltage hereunder specified multiplied by 1,25, whichever is the greater, for a specimen consisting of 2/3 of the number of at least 3 separated layers;

- a test voltage of at least 5 kV or the applicable test voltage hereunder specified multiplied by 1,25, whichever is the greater, for a specimen consisting of one layer of the number of 2 separated layers.

No flashover or breakdown shall occur during the test; corona effects and similar phenomena shall be disregarded.

Table N.1 – Electric strength test voltage required during the mandrel test

| | | | | | | |
|--------------------------------------------------------------------------------------------------------------------------------------------|-----|-------|-------|-------|-------|-------|
| RMS working voltage not exceeding V | 50 | 150 | 250 | 500 | 750 | 1 000 |
| Test voltage, over double or reinforced insulation, between the body and live parts, to be multiplied by 1,25 or 1,35 (see above) V | 500 | 2 800 | 3 750 | 4 750 | 5 200 | 5 500 |
| Values of dielectric strength test voltage for intermediate values of working voltage are found by interpolation between tabulated values. | | | | | | |

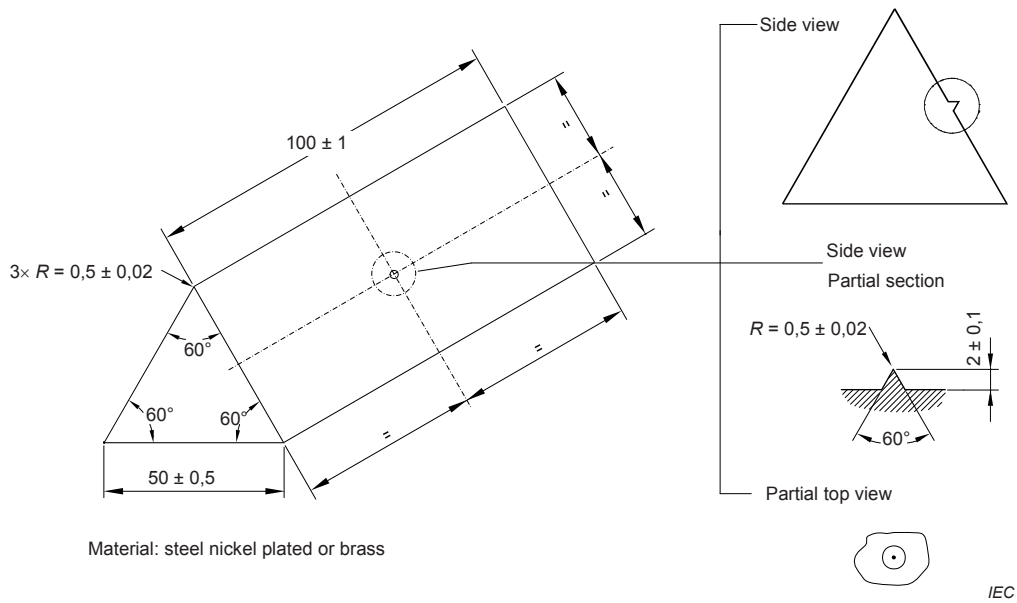

a) Mandrel

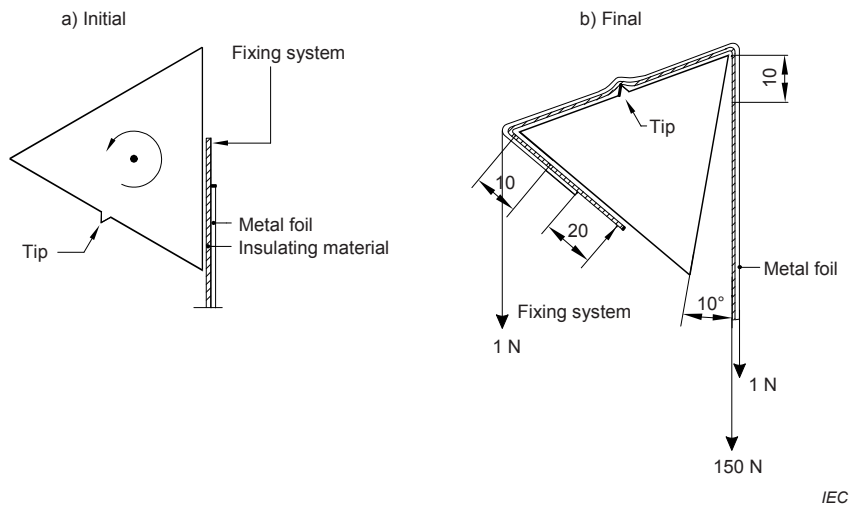

b) Position of mandrel

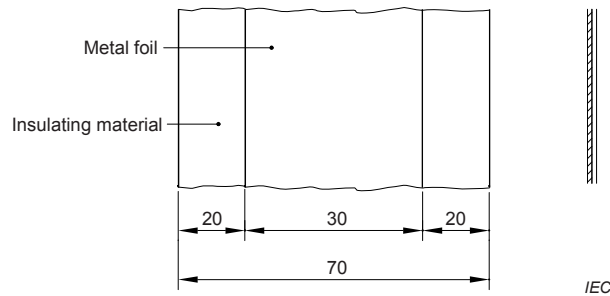

c) Position of metal foil on paper

Figure N.1 – Test arrangement for checking mechanical withstanding of insulating materials in thin sheet layers

Annex O (normative)

Additional requirements for built-in electronic controlgear with double or reinforced insulation

O.1 General

This annex applies to electronic controlgear for building-in having double or reinforced insulation.

O.2 Terms and definitions

For the purposes of this annex, the following terms and definitions apply.

O.2.1

built-in electronic controlgear with double or reinforced insulation

electronic lamp controlgear designed to build into a luminaire, a box, an enclosure or the like and not intended to be mounted outside a luminaire in which accessible metallic parts are insulated from live parts by double or reinforced insulation

Note 1 to entry: An application of electronic controlgear with double or reinforced insulation could be in a class II luminaire with a metallic enclosure.

Note 2 to entry: The requirements also apply to the functional earth terminal of an electronic controlgear because there are no requirements for the insulation of the functional earth wire.

O.2.2

basic insulation

insulation applied to live parts to provide basic protection against electric shock

O.2.3

supplementary insulation

independent insulation applied in addition to basic insulation in order to provide protection against electric shock in the event of failure of basic insulation

O.2.4

double insulation

insulation comprising both basic insulation and supplementary insulation

O.2.5

reinforced insulation

single insulation system applied to live parts, which provides a degree of protection against electric shock equivalent to double insulation

Note 1 to entry: The term "insulation system" does not imply that the insulation shall be one homogeneous piece. it may comprise several layers, which cannot be tested singly as supplementary or basic insulation.

O.3 General requirements

Clause 4 of this standard applies.

O.4 General notes on tests

Clause 5 of this standard applies.

O.5 Classification

Clause 6 of this standard applies.

O.6 Marking

In addition to the marking mentioned under 7.1 of this standard, electronic controlgear with double or reinforced insulation shall be identified by the symbol:



[SOURCE: IEC 60417-6295 (2014-09)]

The meaning of this marking shall be explained in the manufacturer's literature or catalogue.

O.7 Protection against accidental contact with live parts

In addition to the requirements of Clause 10 of this standard, it shall not be possible for the test finger to make contact with metal parts protected by basic insulation only.

O.8 Terminals

Clause 8 of this standard applies.

O.9 Provision for earthing

For doubled or reinforced built-in electronic controlgear only functional earthing terminals are permitted. The requirements of Clause 9 of this standard apply to the functional earthing terminals.

Protective earthing terminals are not permitted.

O.10 Moisture resistance and insulation

Clause 11 of this standard applies.

O.11 Electric strength

Clause 12 of this standard applies.

O.12 Thermal endurance of windings

Clause 13 is not applicable.

O.13 Fault conditions

Clause 14 is applicable with the following addition:

At the end of the tests, when the controlgear has returned to the ambient temperature, it shall comply with a dielectric strength test according to Clause O.12 between live part and accessible metal parts (or external parts of insulating material in contact with the supporting

surface). However the values of the test voltage is reduced to 35 % of the specified values in Table 1.

Furthermore, the insulation resistance according to Clause O.10 between live part and accessible metal parts or external parts of insulating material in contact with the supporting surface shall not be less than 4 MΩ.

O.14 Construction

Clause 15 applies with the following addition:

All accessible metal parts of the electronic built-in electronic controlgear shall be insulated from live parts by double or reinforced insulation. Furthermore the insulation between live part and the supporting surface in contact with the external faces of the controlgear shall consist of double or reinforced insulation.

O.15 Creepage distances and clearances

Clause 16 applies with the following addition:

For built-in electronic controlgear, provided with double or reinforced insulation, the corresponding values given for luminaires in IEC 60598-1 apply.

O.16 Screws, current-carrying parts and connections

Clause 17 of this standard applies.

O.17 Resistance to heat and fire

Clause 18 of this standard applies.

O.18 Resistance to corrosion

Clause 19 of this standard applies.

Annex P (normative)

Creepage distances and clearances and distance through isolation (DTI) for lamp controlgear which are protected against pollution by the use of coating or potting

P.1 General

If the unpotted/uncoated sample of the controlgear complies with Clause 16, the controlgear is treated like an unpotted/uncoated controlgear.

If the creepage distance is less than the minimum distance according to Tables 7 and 8, Clause P.2 of this annex applies.

If the clearance of the unpotted/uncoated sample is less than the minimum distance according to Tables 9, 10 and 11, Clause P.3 of this annex applies.

P.2 Creepage distances

P.2.1 General

Creepage distances for lamp controlgear which are protected against pollution by the use of coating or potting may be reduced to the minimum values as given in P.2.2 or P.2.3, under the condition that the lamp controlgear complies with the tests of P.2.4.

NOTE The values in the tables of this annex are based on pollution degree 1 of IEC 60664-1 and IEC 60664-4.

P.2.2 Minimum creepage distances for working voltages and rated voltage with frequencies up to 30 kHz

Table P.1 defines the minimum creepage distance values for working voltages and rated voltages with frequencies up to 30 kHz for all insulating materials. There is no distinction into different PTI classes.

Table P.1 – Minimum creepage distances for working voltages and rated voltages with frequencies up to 30 kHz

| Distances mm | RMS working/rated voltage not exceeding V | | | | | |
|----------------------------------------------------------------------------------------------------------------------------|----------------------------------------------|------|------|-----|-----|-------|
| | 50 | 150 | 250 | 500 | 750 | 1 000 |
| Basic or supplementary insulation | 0,18 | 0,32 | 0,56 | 1,3 | 2,2 | 3,2 |
| Reinforced insulation | 0,36 | 0,64 | 1,12 | 2,6 | 4,4 | 6,4 |
| Linear interpolation between columns is allowed. | | | | | | |
| For creepage distances the equivalent d.c. voltage is equal to the r.m.s. value of the sinusoidal a.c. voltage. | | | | | | |
| NOTE In Japan and North America, the values given here are not applicable. Japan and North America requires larger values. | | | | | | |

P.2.3 Creepage distances for working voltages with frequencies above 30 kHz

Table P.2 defines the minimum creepage distance values for working voltages with frequencies above 30 kHz for all insulation materials (except for glass, ceramic or other inorganic materials, which do not track). There is no distinction into different PTI classes.

For working voltages with frequencies above 30 kHz the peak value of the voltage shall be considered, because partial discharges damage the surfaces and may cause tracking.

The peak value of the working voltage excludes small peaks or transients like ignition voltages, unless these peaks increase the declared r.m.s. value of the working voltage (U_{out}) by 10 % or more.

The verification has to be done for the worst case condition.

Table P.2 – Minimum value of creepage distances for sinusoidal or non-sinusoidal working voltages at different frequency ranges; basic or supplementary insulation

| Peak value of the working voltage \hat{U}_{out} kV | Creepage distances (pollution degree 1) mm | | | |
|------------------------------------------------------------|-----------------------------------------------|-------------------------------------|-------------------------------------|-------------------------------------|
| | 30 kHz $\leq f \leq$ 100 kHz | 100 kHz $\leq f \leq$ 200 kHz | 200 kHz $\leq f \leq$ 400 kHz | 400 kHz $\leq f \leq$ 700 kHz |
| 0,1 | 0,02 | a | a | a |
| 0,2 | 0,04 | a | a | a |
| 0,3 | 0,08 | 0,09 | 0,09 | 0,09 |
| 0,4 | 0,13 | 0,13 | 0,15 | 0,19 |
| 0,5 | 0,18 | 0,19 | 0,25 | 0,4 |
| 0,6 | 0,27 | 0,27 | 0,40 | 0,85 |
| 0,7 | 0,36 | 0,38 | 0,68 | 1,9 |
| 0,8 | 0,45 | 0,55 | 1,1 | 3,8 |
| 0,9 | 0,53 | 0,82 | 1,9 | 8,7 |
| 1 | 0,60 | 1,15 | 3 | 18 |
| 1,1 | 0,68 | 1,70 | 5 | a |
| 1,2 | 0,85 | 2,40 | 8,2 | a |
| 1,3 | 1,20 | 3,50 | a | a |
| 1,4 | 1,65 | 5,00 | a | a |
| 1,5 | 2,30 | 7,30 | a | a |
| 1,6 | 3,15 | a | a | a |
| 1,7 | 4,40 | a | a | a |
| 1,8 | 6,10 | a | a | a |

Linear interpolation between columns and rows is allowed. The values listed in the columns are valid for the maximum frequency of this column.

For the creepage distances the peak voltage of the working voltage is applied. Transients or small peaks (ignition voltages) which do not significantly increase the r.m.s. of the declared working voltage U_{out} are neglected.

For reinforced insulation the doubled values of the basic or supplementary insulation are required.

NOTE In Japan and North America, the values given here are not applicable. Japan and North America requires larger values.

^a No values available

P.2.4 Compliance with the required creepage distances

P.2.4.1 General

Compliance is checked in accordance with 16.3.3 and by performing the tests of P.2.4.2.

NOTE Additional samples without coating or potting could be necessary for verification.

The tests are conducted on three additional specimens who have not been used for any other test.

No failure of any specimen under test is permitted.

P.2.4.2 Preconditioning of the lamp control gear

P.2.4.2.1 Rapid change of temperature

The rapid change of temperature conditioning is in accordance with test Na of IEC 60068-2-14. The minimum temperature is set at $-10\text{ }^{\circ}\text{C}$ and the maximum temperature is set at $+125\text{ }^{\circ}\text{C}$.

The conditioning is carried out as follows:

- duration of one cycle 1 h (30 min \pm 2 min at each temperature)
- rate of change of temperature within 30 s
- number of cycles: 5

P.2.4.2.2 Moisture resistance

The lamp controlgear is placed in the most unfavourable position of normal use, in a humidity cabinet containing air with a relative humidity maintained between 91 % and 95 %. The temperature of the air at all places where samples can be located shall be maintained within $1\text{ }^{\circ}\text{C}$ of any convenient value t between $20\text{ }^{\circ}\text{C}$ and $30\text{ }^{\circ}\text{C}$.

Before being placed in the humidity cabinet, the sample is brought to a temperature between t and $(t + 4)\text{ }^{\circ}\text{C}$. The sample shall be kept in the cabinet for 48 h.

In order to achieve the specified conditions within this cabinet, it is necessary to ensure constant circulation of the air within, and, in general, to use a cabinet which is thermally insulated.

NOTE In most cases, the sample can be brought to the specified temperature between t and $(t + 4)\text{ }^{\circ}\text{C}$ by keeping it in a room at this temperature for at least 4 h before the humidity treatment.

P.2.4.3 Electrical tests after conditioning

P.2.4.3.1 Insulation resistance and electric strength

Immediately after the preconditioning the specimens are subjected to the insulation resistance and electric strength tests according to Clause 11 and 12.

Before the insulation test, visible drops of water, if any, are removed by means of blotting paper.

P.3 Distance through isolation

P.3.1 General

Clearances do not exist within lamp controlgear which is protected against pollution by the use of coating or potting. Therefore, no clearance values are required.

The insulation should be considered as solid insulation and shall comply with the requirements for distances through insulation and shall be tested in accordance with the tests of P.3.2.

The tests are conducted on three additional specimens, which have not been used for any other test.

No failure of any specimen under test is permitted.

P.3.2 Compliance tests

The suitability of protection is evaluated by carrying out all the tests described in P.3.4 immediately after the conditioning described in P.3.3.

The tests are conducted on three specimens, which have not been used for any other test.

NOTE The test described in P.3.2 is the same as required in P.2.4.1 so it is not necessary to repeat the preconditioning test sample already tested according to Clause P.2.

No failure of any specimen under test is permitted.

P.3.3 Preconditioning of the lamp controlgear

P.3.3.1 Rapid change of temperature

The rapid change of temperature conditioning is in accordance with test Na of IEC 60068-2-14. The minimum temperature is set at -10 °C and the maximum temperature is set at $+125\text{ °C}$.

The conditioning is carried out as follows:

- duration of one cycle 1 h (30 min \pm 2 min at each temperature)
- rate of change of temperature within 30 s
- number of cycles: 5

P.3.3.2 Moisture resistance

The lamp controlgear is placed in the most unfavorable position of normal use, in a humidity cabinet containing air with a relative humidity maintained between 91 % and 95 %. The temperature of the air at all places where samples can be located shall be maintained within 1 °C of any convenient value t between 20 °C and 30 °C .

Before being placed in the humidity cabinet, the sample is brought to a temperature between t and $(t + 4)\text{ °C}$. The sample shall be kept in the cabinet for 48 h.

In order to achieve the specified conditions within this cabinet, it is necessary to ensure constant circulation of the air within, and, in general, to use a cabinet which is thermally insulated.

NOTE In most cases, the sample can be brought to the specified temperature between t and $(t + 4)\text{ °C}$ by keeping it in a room at this temperature for at least 4 h before the humidity treatment.

P.3.4 Electrical tests after conditioning

P.3.4.1 Insulation resistance and electric strength

Immediately after the preconditioning the specimens are subjected to the insulation resistance and electric strength tests according to Clause 11 and 12.

Before the insulation test, visible drops of water, if any, are removed by means of blotting paper.

P.3.4.2 Impulse voltage dielectric test

The purpose of this test is to verify that clearances will withstand specified transient overvoltages.

The impulse withstand test is carried out with a voltage having a 1,2/50 μ s waveform with the values specified in Table P.3 between the insulation barrier where the clearance reduction has been applied, input/output terminals short-circuited and the body.

**Table P.3 – Impulse withstand test voltage
for products of impulse withstand category II**

| Impulse withstand test voltage V | RMS working/rated voltage not exceeding V | | | | | |
|----------------------------------------------------------------------------------------------------|-------------------------------------------------|-------|-------|-------|-------|-------|
| | 50 | 150 | 250 | 500 | 750 | 1 000 |
| Basic or supplementary insulation | 600 | 1 750 | 3 000 | 5 000 | 7 400 | 7 400 |
| Reinforced insulation | 1 000 | 3 000 | 5 000 | 7 400 | 9 900 | 9 900 |
| Linear interpolation between columns is not allowed | | | | | | |
| NOTE The values of this table applicable to impulse withstand category III are given in Table T.2. | | | | | | |

For the waveform, 6.1 and 6.2 of IEC 61180-1:1992 apply. It is intended to simulate overvoltages of atmospheric origin and covers overvoltages due to switching of low-voltage equipment.

The output impedance of the impulse generator shall not be higher than 500 Ω . When carrying out tests on equipment incorporating components across the test circuit, much lower virtual impulse generator impedance should be specified (see 9.2 in IEC 61180-2:1994). In such cases, possible resonance effects, which can increase the peak value of the test voltage, should be taken into account when specifying test voltage values.

The test shall be conducted for five impulses of each polarity with an interval of at least 1 s between pulses in the following conditions.

Normal laboratory conditions are specified in IEC 60068-1:

- temperature: 15 °C to 35 °C;
- air pressure: 86 kPa to 106 kPa at sea level;
- relative humidity: 25 % to 75 %.

No puncture or partial breakdown of solid insulation shall occur during the test, but partial discharges are allowed. Partial breakdown will be indicated by a step in the resulting wave shape which will occur earlier in successive impulses. Breakdown on the first impulse may either indicate a complete failure of the insulation system or the operation of overvoltage limiting devices in the equipment.

If overvoltage limiting devices are included in the equipment, care shall be taken to examine the wave shape to ensure that their operation is not taken to indicate insulation failure. Distortions of the impulse voltage which do not change from impulse to impulse can be caused by operation of such overvoltage limiting device and do not indicate a (partial) breakdown of solid insulation.

NOTE Partial discharges in voids can lead to partial notches of extremely short durations which can be repeated in the course of an impulse.

Annex Q (informative)

Example for U_p calculation

In this Annex Q, an example for the calculation of the U_p value is given.

Figure Q1 shows an example of the U_p calculation in Table 11 with the three steps a (red), b (red) and c (green).

Steps for the calculation are as follows:

- a) U_{peak} with $f > f_{\text{crit}} = 5 \text{ kV}$ gives a minimum clearance value of 12,1 mm (Table 11) or 6,31 mm (Table 10);
- b) the minimum clearance value of 6,31 mm or 12,1 mm is also required for a U_{peak} value of 6,5 kV as defined under column A in Table 10 or in Table 11;
- c) therefore U_p (equivalent output peak voltage as defined under 3.46) has the value of 6,5 kV.

The U_p of 6,5 kV specified a clearance distance with a maximum of 12,1 mm. That means a lamp holder with this information could be used for an electronic controlgear with U_{peak} of 5 kV and 200 kHz or for U_{peak} of 4,5 kV with 700 kHz (resonance ignition).

| Voltage ^a \hat{U}_{out} kV | A | B | C | D | E |
|---------------------------------------------------|-----------------------------------------|-------------------------------------|--------------------------|---------------------------------------|---------------------------------------|
| | | | $f \leq 200 \text{ kHz}$ | 200 kHz < $f \leq 400 \text{ kHz}$ | 400 kHz < $f \leq 700 \text{ kHz}$ |
| | | $f \leq f_{\text{crit}}$ | $f > f_{\text{crit}}$ | | |
| | Transients or ignition pulse voltage | Ignition voltage or working voltage | | | |
| | Minimum distances mm | | | | |
| 0,33 | 0,2 | 0,06 | 0,06 | 0,06 | 0,06 |
| 0,4 | | 0,08 | 0,08 | 0,08 | 0,08 |
| 0,5 | | 0,10 | 0,10 | 0,10 | 0,10 |
| 1,0 | 0,6 | 0,87 | 0,87 | 0,96 | 1,14 |
| 1,5 | 1,4 | 1,7 | 1,77 | 1,96 | 2,26 |
| 2,0 | 2,2 | 2,7 | 2,9 | 3,2 | 3,7 |
| 2,5 | 3,0 | 3,8 | 4,2 | 4,7 | 5,5 |
| 3,0 | 3,8 | 5,3 | 5,8 | 6,5 | 7,7 |
| 4,0 | 6,0 | 8,5 | 9,1 | 9,8 | 10,8 |
| 5,0 | 8,0 | 11,0 | 12,1 | 13,2 | 14,9 |
| 6,0 | 10,4 | 14,3 | 15,6 | 16,8 | 18,6 |
| 8,0 | | 20,6 | b | b | b |
| 10,0 | | 26,8 | b | b | b |

IEC

Figure Q.1 – Example for the calculation of U_p

Annex R (informative)

Concept of creepage distances and clearances

R.1 Basic concept considerations

R.1.1 Creepage distances

For creepage distances r.m.s. voltages are normally considered and pulse voltages like transients are disregarded. In case of voltages with more than 30 kHz frequency however, according to IEC 60664-4, the peak values of the voltage together with the frequency should be considered. Therefore Table 8 was created according to Table 2 in IEC 60664-4:2005.

R.1.2 Clearances

The withstand voltage of a clearance is influenced by the shape of the electric field. IEC 60664-1 distinguishes only homogeneous field (two balls of 1 m diameter) and inhomogeneous field (needle of 30 μm against plane of 1 m \times 1 m).

According to IEC 60664-4 the withstand voltage of a clearance is reduced when the frequency of this voltage is increased above a critical value.

a) Homogeneous field conditions

For homogeneous field conditions, this reduction increases up to 20 % at a frequency of 3 MHz. This means, that a clearance at 3 MHz has only 80 % of the withstand voltage as at 50 Hz. To design a clearance for a certain voltage at 3 MHz the clearance has to be designed for 125 % of that voltage at 50 Hz.

b) Inhomogeneous field condition

In inhomogeneous fields the reduction of the withstand voltage dependent on the frequency can even be more than 50 %. For the worst case (needle with 5 μm radius against a flat plane) at a frequency of 460 kHz it is shown, that there will be a breakdown of a clearance of 7 mm at a voltage of only 3 kV.

Therefore IEC 60664 requires for inhomogeneous field conditions, that partial discharge in air has to be avoided.

c) Practical field condition

This however leads to such large designs that they cannot be used in practice. Probably this is the reason, why the intermediate field conditions are introduced as the "approximately homogeneous field". It is defined as a field between electrodes that have a radius of at least 20 % of the distance between these electrodes. TC 109 regards this intermediate field to behave like homogeneous field and says in 4.3.3 of IEC 60664-4:2005 "It is assumed that these characteristics are also applicable for approximately homogeneous field conditions."

In luminaires very seldom "approximately homogeneous fields" are used but nearly never a field condition applies like a needle with 5 μm radius against a flat plane. Unfortunately the most relevant documents mentioned in the Bibliography of IEC 60664-4:2005 are not publicly available. There was no possibility to really clarify, for example, the time effect of partial discharge. Therefore the first working group started the work on high frequency voltage stress and discussed this matter with members of TC 109.

The conclusion of these discussions was as follows:

- the electric field in luminaires generally has no extremely inhomogeneous shape;
- therefore partial discharges are not regarded to have a major effect on our clearances;
- nevertheless the 50 % reduction of the withstand voltage at 3 MHz were considered;

- it is assumed that the same correction formula applies like for approximately homogeneous field conditions, but adopted to the 50 % voltage reduction.

With these postulates it was possible to set up the requirements for clearances.

A small problem might be that the term “inhomogeneous field” has not been replaced by a new term, but for the purpose of luminaires and their components this seemed to be acceptable.

R.2 Why setting up tables?

All tables are set up by fixed relations using the Tables F.2 and F.7a of IEC 60664-1:2007. In a very early state the decision was made to create tables in order to give very simple and clear guidance to the designers. It was intended to avoid any discussion between test houses and designers and to avoid long and complicated explanations that would have been needed in the standards.

It was accepted, that by setting up columns some possible advantages get lost but the intention was, to avoid a cloud of very similar but nevertheless different designs for the same purpose. Accordingly marking with rated values would be very difficult.

The reason why values for reinforced and double insulation are introduced is related to generally new requirements that do not depend on the high frequency voltage stress.

The idea was to set up the new requirements in a way that a clear relation to IEC 60664 series is shown and that it later will be possible, to easily adopt future changes of the horizontal standard to our standards.

Annex S (informative)

Examples of controlgear insulation coordination

Controlgear are general classified as integral, built-in or independent-controlgear. For each of the different controlgear types the insulation philosophy “two lines of defence” shall be fulfilled. The controlgear insulation coordination should be considered together with the application. Figure S.1 shows as an example the schematic of controlgear insulation coordination in regard to the two lines of defence insulation philosophy.

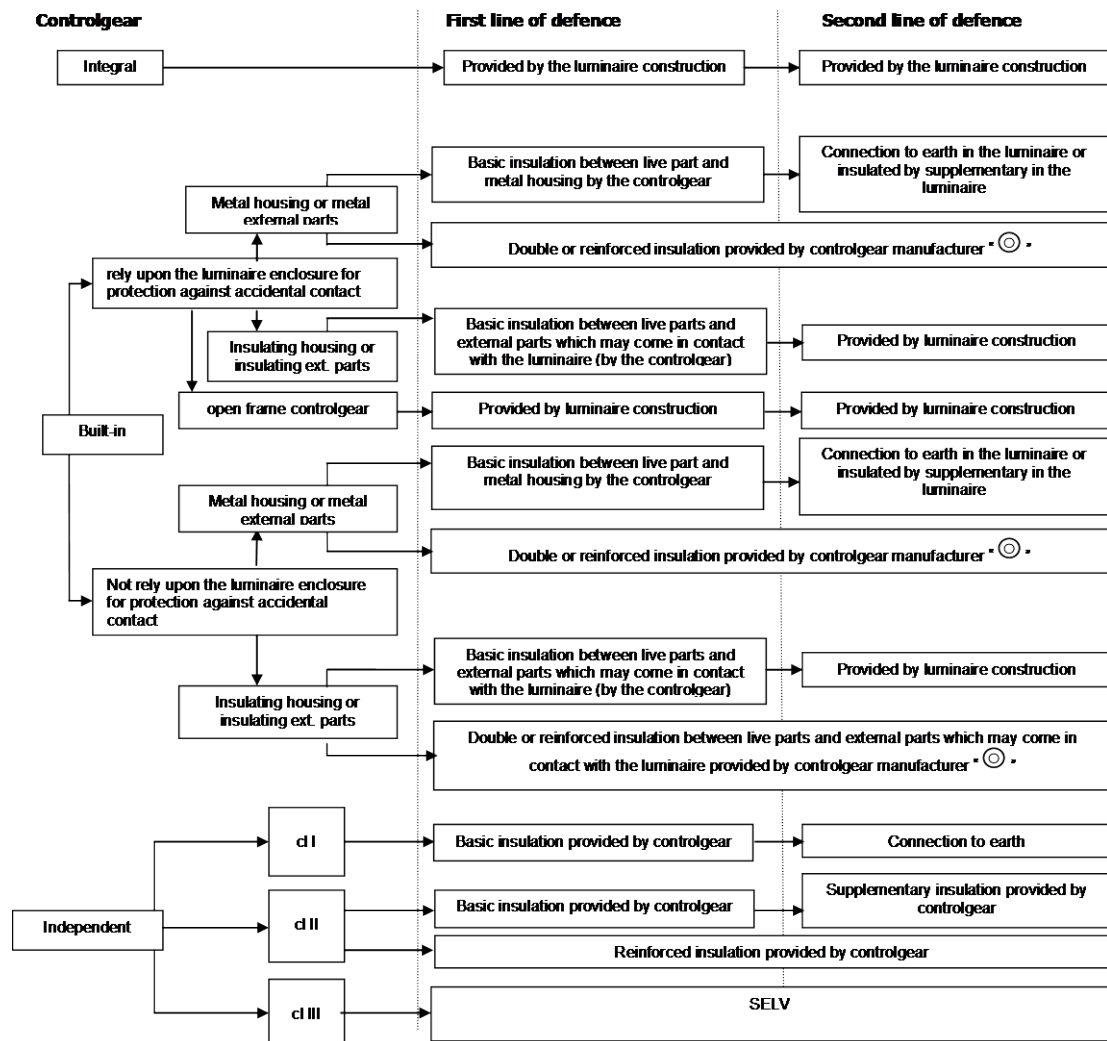

IEC

Figure S.1 – Example of schematic drawings, showing the different controlgear insulation coordination

Dependent on the protection against electric shock are independent controlgear available as class I (cl I), class II (cl II) or class III (cl III) units (for the definition see IEC 60598-1).

Annex T (informative)

Creepage distances and clearances for controlgear with a higher degree of availability (impulse withstand category III)

T.1 General

Creepage distances and clearance limits detailed in Clause 16 of this standard have been established with reference to IEC 60664 and based on impulse withstand category II. This level of impulse withstand category is considered appropriate for normal usage of controlgear covered under the scope of IEC 61347-1.

This informative annex details the more onerous requirements of IEC 60664 which would allow controlgear to have a higher over-voltage capability for an impulse withstand category III should a higher degree of impulse withstand category be requested.

T.2 Clearances for working voltages of lamp controlgear not protected against pollution by coating or potting materials

Requirements for impulse withstand category III are given in the Table T.1. These limits are applied in place of those given in Table 9 of this standard should a rating of impulse withstand category III be requested.

NOTE For details of pollution degrees, see IEC 60664-1.

The minimum distances specified are based on the following parameters:

- for use with up to 2 000 m above sea level;
- pollution degree 2 where normally only non-conductive pollution occurs but occasionally a temporary conductivity caused by condensation is to be expected;
- equipment of impulse withstand category III, which is equipment in fixed installations and for cases where the reliability and the availability of the equipment is subject to special requirements.

**Table T.1 – Minimum clearances for working voltages –
Impulse withstand category III**

| Distances ^a mm | RMS working voltage not exceeding V | | | | | |
|-----------------------------------------------------------------------------------------------------------------------------------------------------------------------------|----------------------------------------|-----|-----|-----|------|-------|
| | 50 | 150 | 250 | 500 | 750 | 1 000 |
| Clearance with mains supply transients according to impulse withstand category III ^a | | | | | | |
| – basic or supplementary insulation | 0,2 | 1,5 | 3 | 5,5 | 8 | 8 |
| – reinforced insulation | 0,5 | 3 | 5,5 | 8,0 | 14 | 14 |
| Clearance without mains supply transients ^a | | | | | | |
| – basic or supplementary insulation | 0,2 | 0,2 | 0,2 | 0,2 | 0,25 | 0,35 |
| – reinforced insulation | 0,5 | 0,4 | 0,4 | 0,4 | 0,50 | 0,70 |
| Linear Interpolation between columns is not allowed, if transients according to the impulse withstand category III have to be considered for the main supply. | | | | | | |
| ^a For clearances, the equivalent d.c. voltage is equal to the peak of the a.c. voltage. | | | | | | |
| NOTE In Japan and North America, the values given in the above table are not applicable. Japan and North America requires larger values than the values given in the table. | | | | | | |

For components in secondary circuits Table 7 applies.

T.3 Clearances for working voltages of lamp controlgear protected against pollution by coating or potting

The impulse withstand test voltages for impulse withstand category III are given in Tables T.2. These impulse withstand test voltages are applied in place of those given in Table P.3 of this standard should a rating of impulse withstand category III be requested. In other respects the requirements of Clause P.3 apply.

Table T.2 – Impulse withstand test voltages of impulse withstand category III for lamp controlgear protected against pollution by coating or potting material

| Impulse withstand test voltage V | RMS working/rated voltage not exceeding V | | | | | |
|------------------------------------------------------|----------------------------------------------|-------|-------|-------|--------|--------|
| | 50 | 150 | 250 | 500 | 750 | 1 000 |
| Basic or supplementary insulation | 1 000 | 3 000 | 5 000 | 7 400 | 9 900 | 9 900 |
| Reinforced insulation | 1 750 | 5 000 | 7 400 | 9 900 | 14 800 | 14 800 |
| Linear interpolation between columns is not allowed. | | | | | | |

T.4 Distances through insulation – Particular additional requirements for controlgear providing SELV

Requirements for impulse withstand category III are given in the Table T.3 these limits are applied in place of those given in Table L.5 of this standard should a rating of impulse withstand category III be requested.

Table T.3 – Distances through insulation (DTI) for the impulse withstand category III/material group IIIa (175 CTI < 400)

Pollution degree 2; dimensions in millimetres

| Distance through insulation mm | Measurement | | Working voltages ^{a c} V | | | |
|----------------------------------------------------------------------------------------------------------------------------------------------------------------------------------------------------------------------------------------------------------------------------------------------------------------------------------------------------------------------------------------------------------------------------------------------------------------------------------------------------------------------------------------------------------------------------------------------------------------------------------------------------------------------------------------------------------------------------------------------------------------------------------------------------------------------------------------------------------------------------------------------------------------------------------------------|-------------------------------------|-----------------------------------|-----------------------------------------|------------------------------------------|------------------------------------------|------------------------------------------|
| | Through winding enamel ^b | Other than through winding enamel | > 25 to < 50 | 100 | 150 | 250 |
| 1) Basic ^f | X | X | No requirement of thickness | | | |
| 2) Supplementary ^f | X | X | 0,1 ^d [0,05] ^e | 0,15 ^d [0,05] ^e | 0,25 ^d [0,08] ^e | 0,42 ^d [0,13] ^e |
| 3) Reinforced (excluding insulation between input and output circuits) | X | X | 0,2 ^d [0,1] ^e | 0,3 ^d [0,1] ^e | 0,5 ^d [0,15] ^e | 0,9 ^d [0,25] ^e |
| See IEC 61558-1:2005, 26.2 (for a1) and 26.3 (for a2), requirements for pollution degree 1 (P1) and IEC 60664-1:2007, Table F.4. | | | | | | |
| <p>^a For working voltages exceeding 300 V, see IEC 61558-1.</p> <p>^b Measurement through winding wire enamel if at least one winding is constructed with wire complying with at least Grade 1 of IEC 60317-0-1.</p> <p>^c Values of distances through insulation may be found for intermediate values of working voltages by interpolation between the values in the table. No values are required for working voltages below 25 V as the voltage test of Table L.3 is considered sufficient.</p> <p>^d For solid insulation.</p> <p>^e In case of insulation consisting of thin sheets.</p> <p>^f When double insulation is required between input and output windings, the total thickness through insulation shall be the same as shown in row 3) whether measured directly or via metals parts, with the exception of insulated wires (see 19.12 of IEC 61558-1:2005).</p> | | | | | | |

Bibliography

IEC 60038, *IEC standard voltages*

IEC TR 60083:2009, *Plugs and socket-outlets for domestic and similar general use standardized in member countries of IEC*

IEC 60155:1993, *Glow-starters for fluorescent lamps*

IEC 60479 (all parts), *Effects of current on human beings and livestock*

IEC 60364-4-41:2001, *Electrical installations of buildings – Part 4 – 41: Protection for safety – Protection against electric shock*

IEC 60364-4-44, *Low-voltage electrical installations – Part 4-44: Protection for safety – Protection against voltage disturbances and electromagnetic disturbances*

IEC 60598 (all parts), *Luminaires*

IEC 60664-3, *Insulation coordination for equipment within low-voltage systems – Part 3: Use of coating, potting or moulding for protection against pollution*

IEC 60925:1989, *DC supplied electronic ballasts for tubular fluorescent lamps – Performance requirements²⁾*

IEC 60925:1989/AMD1:1996,

IEC 60925:1989/AMD2:2001

IEC 60927:2007, *Auxiliaries for lamps – Starting devices (other than glow starters) – Performance requirements*

IEC 60927:2007/AMD1:2013

IEC 60929:2006, *AC-supplied electronic ballasts for tubular fluorescent lamps – Performance requirements*

IEC 60950-1, *Information technology equipment – Safety – Part 1: General requirements*

IEC 60990:1999, *Methods of measurement of touch current and protective conductor current*

IEC 61047:2004, *DC or a.c. supplied electronic step-down convertors for filament lamps – Performance requirements*

IEC 61347-2-1:2000, *Lamp controlgear – Part 2-1: Particular requirements for starting devices (other than glow starters)*

IEC 61347-2-1:2000/AMD1:2005

IEC 61347-2-2:2011, *Lamp controlgear – Part 2-2: Particular requirements for d.c. or a.c. supplied electronic step-down convertors for filament lamps*

IEC 62384, *DC or AC supplied electronic controlgear for LED modules – Performance requirements*

IEEE 101:1987, *IEEE Guide for the Statistical Analysis of Thermal Life Test Data*

²⁾ There exists a consolidated edition 1.2 (2001) including the base publication and its Amendments 1 and 2.

British Standards Institution (BSI)

BSI is the national body responsible for preparing British Standards and other standards-related publications, information and services.

BSI is incorporated by Royal Charter. British Standards and other standardization products are published by BSI Standards Limited.

About us

We bring together business, industry, government, consumers, innovators and others to shape their combined experience and expertise into standards-based solutions.

The knowledge embodied in our standards has been carefully assembled in a dependable format and refined through our open consultation process. Organizations of all sizes and across all sectors choose standards to help them achieve their goals.

Information on standards

We can provide you with the knowledge that your organization needs to succeed. Find out more about British Standards by visiting our website at bsigroup.com/standards or contacting our Customer Services team or Knowledge Centre.

Buying standards

You can buy and download PDF versions of BSI publications, including British and adopted European and international standards, through our website at bsigroup.com/shop, where hard copies can also be purchased.

If you need international and foreign standards from other Standards Development Organizations, hard copies can be ordered from our Customer Services team.

Subscriptions

Our range of subscription services are designed to make using standards easier for you. For further information on our subscription products go to bsigroup.com/subscriptions.

With **British Standards Online (BSOL)** you'll have instant access to over 55,000 British and adopted European and international standards from your desktop. It's available 24/7 and is refreshed daily so you'll always be up to date.

You can keep in touch with standards developments and receive substantial discounts on the purchase price of standards, both in single copy and subscription format, by becoming a **BSI Subscribing Member**.

PLUS is an updating service exclusive to BSI Subscribing Members. You will automatically receive the latest hard copy of your standards when they're revised or replaced.

To find out more about becoming a BSI Subscribing Member and the benefits of membership, please visit bsigroup.com/shop.

With a **Multi-User Network Licence (MUNL)** you are able to host standards publications on your intranet. Licences can cover as few or as many users as you wish. With updates supplied as soon as they're available, you can be sure your documentation is current. For further information, email bsmusales@bsigroup.com.

BSI Group Headquarters

389 Chiswick High Road London W4 4AL UK

Revisions

Our British Standards and other publications are updated by amendment or revision.

We continually improve the quality of our products and services to benefit your business. If you find an inaccuracy or ambiguity within a British Standard or other BSI publication please inform the Knowledge Centre.

Copyright

All the data, software and documentation set out in all British Standards and other BSI publications are the property of and copyrighted by BSI, or some person or entity that owns copyright in the information used (such as the international standardization bodies) and has formally licensed such information to BSI for commercial publication and use. Except as permitted under the Copyright, Designs and Patents Act 1988 no extract may be reproduced, stored in a retrieval system or transmitted in any form or by any means – electronic, photocopying, recording or otherwise – without prior written permission from BSI. Details and advice can be obtained from the Copyright & Licensing Department.

Useful Contacts:

Customer Services

Tel: +44 845 086 9001

Email (orders): orders@bsigroup.com

Email (enquiries): cservices@bsigroup.com

Subscriptions

Tel: +44 845 086 9001

Email: subscriptions@bsigroup.com

Knowledge Centre

Tel: +44 20 8996 7004

Email: knowledgecentre@bsigroup.com

Copyright & Licensing

Tel: +44 20 8996 7070

Email: copyright@bsigroup.com



...making excellence a habit.™