



BSI Standards Publication

Electrostatics

Part 4-9: Standard test methods for
specific applications — Garments

National foreword

This British Standard is the UK implementation of EN 61340-4-9:2016. It is identical to IEC 61340-4-9:2016.

The UK participation in its preparation was entrusted to Technical Committee GEL/101, Electrostatics.

A list of organizations represented on this committee can be obtained on request to its secretary.

This publication does not purport to include all the necessary provisions of a contract. Users are responsible for its correct application.

© The British Standards Institution 2016.

Published by BSI Standards Limited 2016

ISBN 978 0 580 86847 4

ICS 17.220.99; 29.020

Compliance with a British Standard cannot confer immunity from legal obligations.

This British Standard was published under the authority of the Standards Policy and Strategy Committee on 30 September 2016.

Amendments/corrigenda issued since publication

Date	Text affected
-------------	----------------------

EUROPEAN STANDARD
NORME EUROPÉENNE
EUROPÄISCHE NORM

EN 61340-4-9

September 2016

ICS 17.220.99; 29.020

English Version

**Electrostatics - Part 4-9: Standard test methods for specific applications - Garments
(IEC 61340-4-9:2016)**

Électrostatique - Partie 4-9: Méthodes d'essai normalisées
pour des applications spécifiques - Vêtements
(IEC 61340-4-9:2016)

Elektrostatik - Teil 4-9: Standard-Prüfverfahren für spezielle
Anwendungen - Bekleidung
(IEC 61340-4-9:2016)

This European Standard was approved by CENELEC on 2016-06-01. CENELEC members are bound to comply with the CEN/CENELEC Internal Regulations which stipulate the conditions for giving this European Standard the status of a national standard without any alteration.

Up-to-date lists and bibliographical references concerning such national standards may be obtained on application to the CEN-CENELEC Management Centre or to any CENELEC member.

This European Standard exists in three official versions (English, French, German). A version in any other language made by translation under the responsibility of a CENELEC member into its own language and notified to the CEN-CENELEC Management Centre has the same status as the official versions.

CENELEC members are the national electrotechnical committees of Austria, Belgium, Bulgaria, Croatia, Cyprus, the Czech Republic, Denmark, Estonia, Finland, Former Yugoslav Republic of Macedonia, France, Germany, Greece, Hungary, Iceland, Ireland, Italy, Latvia, Lithuania, Luxembourg, Malta, the Netherlands, Norway, Poland, Portugal, Romania, Slovakia, Slovenia, Spain, Sweden, Switzerland, Turkey and the United Kingdom.



European Committee for Electrotechnical Standardization
Comité Européen de Normalisation Electrotechnique
Europäisches Komitee für Elektrotechnische Normung

CEN-CENELEC Management Centre: Avenue Marnix 17, B-1000 Brussels

European foreword

The text of document 101/500/FDIS, future edition 2 of IEC 61340-4-9, prepared by IEC/TC 101 "Electrostatics" was submitted to the IEC-CENELEC parallel vote and approved by CENELEC as EN 61340-4-9:2016.

The following dates are fixed:

- latest date by which the document has to be implemented at national level by publication of an identical national standard or by endorsement (dop) 2017-03-16
- latest date by which the national standards conflicting with the document have to be withdrawn (dow) 2019-09-16

Attention is drawn to the possibility that some of the elements of this document may be the subject of patent rights. CENELEC [and/or CEN] shall not be held responsible for identifying any or all such patent rights.

Endorsement notice

The text of the International Standard IEC 61340-4-9:2016 was approved by CENELEC as a European Standard without any modification.

In the official version, for Bibliography, the following note has to be added for the standard indicated :

IEC 61340-5-1 NOTE Harmonized as EN 61340-5-1.

Annex ZA (normative)

Normative references to international publications with their corresponding European publications

The following documents, in whole or in part, are normatively referenced in this document and are indispensable for its application. For dated references, only the edition cited applies. For undated references, the latest edition of the referenced document (including any amendments) applies.

NOTE 1 When an International Publication has been modified by common modifications, indicated by (mod), the relevant EN/HD applies.

NOTE 2 Up-to-date information on the latest versions of the European Standards listed in this annex is available here: www.cenelec.eu

<u>Publication</u>	<u>Year</u>	<u>Title</u>	<u>EN/HD</u>	<u>Year</u>
IEC 61340-2-3	-	Electrostatics - Part 2-3: Methods of test for determining the resistance and resistivity of solid planar materials used to avoid electrostatic charge accumulation	EN 61340-2-3	-
IEC 61340-4-6	-	Electrostatics - Part 4-6: Standard test methods for specific applications - Wrist straps	EN 61340-4-6	-

CONTENTS

FOREWORD.....	4
INTRODUCTION.....	6
1 Scope.....	7
2 Normative references.....	7
3 Terms and definitions	7
4 Atmosphere for conditioning and testing.....	8
4.1 General.....	8
4.2 Low humidity.....	8
4.3 Moderate humidity.....	9
5 Equipment and materials	9
5.1 Test equipment requirements	9
5.1.1 Resistance measurement apparatus	9
5.1.2 Resistance measurement electrodes	9
5.1.3 Support surface	10
6 Test procedure	10
6.1 Sample preparation.....	10
6.1.1 General	10
6.1.2 Sample size	10
6.1.3 Sample sketch	10
6.2 Humidity requirements.....	11
6.3 Test procedures	11
6.3.1 General	11
6.3.2 Resistance point-to-point.....	11
6.3.3 Resistance point-to-groundable point.....	12
6.3.4 Cuff measurements.....	12
6.3.5 Groundable static control garment system	12
7 Product qualification	12
8 Reporting	13
Annex A (informative) Garment types and resistance values	20
Annex B (informative) Data collection sheet (example)	21
Bibliography	23
Figure 1 – Test set-up – Resistance point-to-point (sleeve-to-sleeve procedure with insulative sleeve inserts).....	13
Figure 2 – Test set-up – Resistance point-to-point (insulative sleeve inserted into sleeve detail).....	14
Figure 3 – Test set-up – Resistance point-to-point (panel-to-panel procedure with insulative support surface)	14
Figure 4 – Test set-up – Resistance point-to-point (cuff-to-cuff procedure with insulative sleeve inserts).....	15
Figure 5 – Test set-up – Resistance point-to-point (electrode inserted into cuff detail).....	15
Figure 6 – Test set-up – Resistance point-to-point (hanging clamp sleeve-to-sleeve procedure).....	16
Figure 7 – Clamps/electrodes for hanging garment test.....	16
Figure 8 – Test set-up – Resistance point-to-groundable point (cuff-to-groundable-point procedure with insulative sleeve inserts).....	17

Figure 9 – Test set-up – Resistance point-to-groundable point (sleeve-to-groundable-point procedure with insulative sleeve inserts)..... 17

Figure 10 – Groundable garment cuff test..... 18

Figure 11 – Test set-up – Groundable static control garment system resistance (groundable garment in combination with a person using a meter and hand-held electrode)..... 18

Figure 12 – Test set-up – Groundable static control garment system resistance (groundable garment in combination with a person using an integrated tester) 19

Table 1 – Product qualification 13

Table A.1 – Garment types and resistance values20

INTERNATIONAL ELECTROTECHNICAL COMMISSION

ELECTROSTATICS –

Part 4-9: Standard test methods for specific applications – Garments

FOREWORD

- 1) The International Electrotechnical Commission (IEC) is a worldwide organization for standardization comprising all national electrotechnical committees (IEC National Committees). The object of IEC is to promote international co-operation on all questions concerning standardization in the electrical and electronic fields. To this end and in addition to other activities, IEC publishes International Standards, Technical Specifications, Technical Reports, Publicly Available Specifications (PAS) and Guides (hereafter referred to as “IEC Publication(s)”). Their preparation is entrusted to technical committees; any IEC National Committee interested in the subject dealt with may participate in this preparatory work. International, governmental and non-governmental organizations liaising with the IEC also participate in this preparation. IEC collaborates closely with the International Organization for Standardization (ISO) in accordance with conditions determined by agreement between the two organizations.
- 2) The formal decisions or agreements of IEC on technical matters express, as nearly as possible, an international consensus of opinion on the relevant subjects since each technical committee has representation from all interested IEC National Committees.
- 3) IEC Publications have the form of recommendations for international use and are accepted by IEC National Committees in that sense. While all reasonable efforts are made to ensure that the technical content of IEC Publications is accurate, IEC cannot be held responsible for the way in which they are used or for any misinterpretation by any end user.
- 4) In order to promote international uniformity, IEC National Committees undertake to apply IEC Publications transparently to the maximum extent possible in their national and regional publications. Any divergence between any IEC Publication and the corresponding national or regional publication shall be clearly indicated in the latter.
- 5) IEC itself does not provide any attestation of conformity. Independent certification bodies provide conformity assessment services and, in some areas, access to IEC marks of conformity. IEC is not responsible for any services carried out by independent certification bodies.
- 6) All users should ensure that they have the latest edition of this publication.
- 7) No liability shall attach to IEC or its directors, employees, servants or agents including individual experts and members of its technical committees and IEC National Committees for any personal injury, property damage or other damage of any nature whatsoever, whether direct or indirect, or for costs (including legal fees) and expenses arising out of the publication, use of, or reliance upon, this IEC Publication or any other IEC Publications.
- 8) Attention is drawn to the Normative references cited in this publication. Use of the referenced publications is indispensable for the correct application of this publication.
- 9) Attention is drawn to the possibility that some of the elements of this IEC Publication may be the subject of patent rights. IEC shall not be held responsible for identifying any or all such patent rights.

International Standard IEC 61340-4-9 has been prepared by IEC technical committee 101: Electrostatics.

This second edition cancels and replaces the first edition published in 2010. This edition constitutes a technical revision.

This edition includes the following significant technical changes with respect to the previous edition:

- a) classification of three types of garments
 - static control garments,
 - groundable static control garments, and
 - groundable static control garment system;

- b) additional measurements according to the the garment type including cuff measurements, panel to groundable point, testing with a person in the garment system;
- c) sleeve to sleeve measurements allowed with probes or by hanging;
- d) additional recommended values for new garment types as set out in Annex A.

The text of this standard is based on the following documents:

FDIS	Report on voting
101/500/FDIS	101/502/RVD

Full information on the voting for the approval of this standard can be found in the report on voting indicated in the above table.

This publication has been drafted in accordance with the ISO/IEC Directives, Part 2.

A list of all parts in the IEC 61340 series, published under the general title *Electrostatics*, can be found on the IEC website.

The committee has decided that the contents of this publication will remain unchanged until the stability date indicated on the IEC website under "<http://webstore.iec.ch>" in the data related to the specific publication. At this date, the publication will be

- reconfirmed,
- withdrawn,
- replaced by a revised edition, or
- amended.

IMPORTANT – The 'colour inside' logo on the cover page of this publication indicates that it contains colours which are considered to be useful for the correct understanding of its contents. Users should therefore print this document using a colour printer.

INTRODUCTION

This part of IEC 61340 provides test methods for evaluating the electrical resistance of garments that contain surface conductive or dissipative components or materials used in the electronics industry for the control of electrostatic discharge. This standard defines procedures for measuring electrical resistance, including a system resistance test for garments that provide a ground path for personnel.

Clothing made from synthetic fibres is a common source of electrostatic charge. Wearing an appropriate static control garment over personal clothing can minimize the effect of this charge. To effectively control electrostatic charges, the static control garment should be grounded.

Three categories of garments are considered in this standard.

- a) A static control garment may suppress or otherwise affect an electric field from clothing worn underneath the garment without being attached to ground. However, without grounding, a charge may accumulate on conductive or dissipative elements of a garment, if present, resulting in a charged source.
- b) A groundable static control garment may provide a higher level of suppression when the lower resistance fabric is connected to ground.
- c) A groundable static control garment system provides a ground path for a person that suppresses the electrical field from clothing worn underneath the garment and also bonds the skin of the wearer to an identified ground path. Groundable static control garment systems may also be used in conjunction with a continuous or constant monitoring system in a manner similar to those used in continuous monitoring of wrist straps in an ESD protected area (EPA).

Resistive characterization is only one aspect to consider in evaluating garments for any specific application. To fully characterize a garment, electrical field attenuation, static decay, peak voltage, residual voltage and triboelectric charging may need to be considered. Other attributes related to applications and environments, such as cleanroom compatibility, chemical and fire resistance, should be evaluated in the garment selection process but are beyond the scope of this standard.

Garments constructed from fabrics made with fibres that are not surface conductive but may have other related properties that impart some level of electrostatic charge dissipation or suppression when connected to ground, are not specifically measured by the methods provided in this standard.

This being the case, some garment fabrics and construction may allow for surface voltage accumulation and charge transfer to occur which may be detrimental to electronic items.

ELECTROSTATICS –

Part 4-9: Standard test methods for specific applications – Garments

1 Scope

This part of IEC 61340 provides test methods for measuring the electrical resistance of garments used for static control applications. These test methods can be used for evaluating outer garments that are homogeneously conductive or homogeneously dissipative, or that utilize surface conductive or surface dissipative components or elements.

NOTE The test methods defined in this standard may not be able to measure materials with buried conductive layers.

The resistance point-to-point test method tests the electrical resistance between the two sleeves, any two panels or any two or more electrically interconnected components of the static control garment, including the electrical resistance across the seams and cuffs of the garment as applicable.

An alternate sleeve-to-sleeve test method is allowed, using clamps to hang a garment.

Static control garments that electrically bond to the wearer and provide a path to ground from the wearer are evaluated using the resistance point-to-point test method, the resistance point to groundable point test method, as well as a system test to determine the resistance from the person through the garment to the groundable point of the garment system.

A band resistance measurement test is provided in IEC 61340-4-6 which can be used for garments so equipped with cuffs that are intended to perform the same function as a wrist strap band.

The system test with a person wearing a groundable static control garment system includes the ground cord that connects to the groundable point of the garment.

2 Normative references

The following documents, in whole or in part, are normatively referenced in this document and are indispensable for its application. For dated references, only the edition cited applies. For undated references, the latest edition of the referenced document (including any amendments) applies.

IEC 61340-2-3, *Electrostatics – Part 2-3: Methods of test for determining the resistance and resistivity of solid planar materials used to avoid electrostatic charge accumulation*

IEC 61340-4-6, *Electrostatics – Part 4-6: Standard test methods for specific applications – Wrist straps*

3 Terms and definitions

For the purposes of this document, the following terms and definitions apply.

3.1**acceptance testing**

testing used to confirm to users that products delivered are substantially the same as the samples used to qualify products

3.2**garment system**

any electrically interconnected components of static control apparel

3.3**point-to-point resistance**

resistance measured from one point to another on the surface of the same panel or two different panels of a garment

Note 1 to entry: Point-to-point resistance is expressed in ohms.

3.4**static control garments**

personnel garments that are designed for electrostatic charge control

3.5**product qualification**

testing used to confirm that products comply with requirements of an ESD control program or other specification

3.6**groundable static control garment**

garment that exhibits an electrical resistance from point-to-point and from any point or panel on the garment to the groundable point on the garment

Note 1 to entry: The groundable point may be a cuff contact to the wearer's skin or separate dedicated grounding point connector.

3.7**groundable static control garment system**

garments that are used to establish the primary ground path for a person to the groundable point of the garment and the connection of the garment to ground, typically through a grounding cord

Note 1 to entry: The garment shall also meet all the requirements included in the definition for groundable static control garments.

4 Atmosphere for conditioning and testing**4.1 General**

The following requirements supersede any other specification for the atmosphere for conditioning and testing that may be given in one or more of the documents referred to in this standard.

4.2 Low humidity

Unless otherwise agreed, the atmosphere for conditioning and testing for laboratory evaluations at low humidity shall be at a temperature of $23\text{ °C} \pm 2\text{ °C}$ and $12\% \pm 3\%$ relative humidity. The conditioning time prior to testing shall be at least 48 h.

4.3 Moderate humidity

The atmosphere for conditioning and testing for laboratory evaluations at moderate humidity shall be at a temperature of $23\text{ °C} \pm 2\text{ °C}$ and $50\% \pm 2\%$ relative humidity. The conditioning time prior to testing shall be at least 48 h.

5 Equipment and materials

5.1 Test equipment requirements

5.1.1 Resistance measurement apparatus

5.1.1.1 General

The measurement apparatus, called the meter, whether it is a single meter or collection of instruments, shall be capable of the following.

5.1.1.2 Product qualification

The meter shall have a circuit voltage while under load of 100 V ($\pm 5\%$) for measurements of $1,0 \times 10^6\ \Omega$ and above, and 10 V ($\pm 5\%$) for measurements less than $1,0 \times 10^6\ \Omega$.

The meter shall be capable of making measurements from $1,0 \times 10^3\ \Omega$ to $1,0 \times 10^{12}\ \Omega$.

5.1.1.3 Acceptance testing

The product qualification meter may be used for acceptance testing or the following:

The meter shall have an open circuit voltage of 100 V ($\pm 5\%$) for measurements of $1,0 \times 10^6\ \Omega$ and above, and 10 V ($\pm 5\%$) for measurements less than $1,0 \times 10^6\ \Omega$.

The meter shall be capable of making measurements for $1,0 \times 10^3\ \Omega$ to $1,0 \times 10^{12}\ \Omega$.

In case of disagreement the meter used for product qualification will be used to resolve any disputes.

5.1.1.4 Ohmmeter for testing personal ground path

Integrated checker or meter, whether it is a single meter (ohmmeter) or a collection of instruments that are capable of measuring from $5,0 \times 10^4\ \Omega$ to at least $1,0 \times 10^8\ \Omega$ with a test voltage from 7 V to 30 V DC open circuit.

Both test leads should be capable of being isolated from ground. AC line-powered resistance measuring devices may give erroneous results due to undefined ground paths. Battery powered equipment is recommended.

5.1.2 Resistance measurement electrodes

5.1.2.1 Cylindrical electrodes

A cylindrical $2,5\text{ kg} \pm 0,25\text{ kg}$ rubber electrode with a diameter of $65\text{ mm} \pm 0,5\text{ mm}$, having a contact of electrically conductive material with a Shore-A (IRHD) durometer hardness between 50 and 70. The resistance between two electrodes should be less than $1,0 \times 10^3\ \Omega$ when measured at 10 V on a metallic surface.

5.1.2.2 Clamps/electrodes

The clamps/electrodes shall consist of two flat electrically conductive plates (e.g. stainless steel) with a dimension of approximately 50 mm × 25 mm each. The clamp/electrodes shall be electrically conductive with sufficient compression force to retain and suspend the garment. See Figure 7.

5.1.2.3 Cuff test fixture

A test fixture comprising an insulative stand and two stainless steel cylinders approximately 25 mm in diameter, with one cylinder fixed to the stand directly above the second. The second cylinder will weigh approximately 0,11 kg and is mounted in a slot in the stand that allows free vertical movement. See Figure 10.

5.1.2.4 Hand-held electrode

A stainless steel, brass or copper round or tubular stock, approximately 25 mm in diameter and 75 mm or greater in length, with provision for connection to meter (such as a banana plug receptacle or screw connector) attached to one end of the cylinder. See Figure 11.

5.1.3 Support surface

5.1.3.1 Insulative support surface

An insulative surface when used for specimen support shall have a surface resistance of greater than $1,0 \times 10^{12} \Omega$ when measured in accordance with IEC 61340-2-3. The insulative surface shall be large enough to accommodate the entire garment when it is laid out flat.

5.1.3.2 Insulative sleeve inserts

Two pieces of insulative material meeting the requirements of 5.1.3.1 cut into approximately 75 mm by 152 mm strips to slide into the sleeves (and cuffs if so equipped) of garments under test to isolate one side of the sleeve from the other.

5.1.3.3 Insulative hangers

The points to which the clamps described in 5.1.2.2 holding a garment under test shall be isolated from ground to a resistance greater than $1,0 \times 10^{12} \Omega$ when measured with an instrument meeting the requirements of 5.1.1.3. Insulating thread may be used for this purpose.

6 Test procedure

6.1 Sample preparation

6.1.1 General

The test samples shall be processed through a minimum of five cycles of the garment manufacturer's prescribed or user defined cleaning process prior to performing laboratory tests.

6.1.2 Sample size

Test a minimum of three samples for each style and manufacturer for product qualification. For acceptance testing, the sample size shall be determined by the user.

6.1.3 Sample sketch

The person performing the tests should examine the garment's construction and make a general sketch showing separate front and back panels used to fabricate the garment.

Number the panels for measurement identification purposes from N° 1 to N° *n*. Identify the sleeves and cuffs as left and right. The groundable points, if they exist, should be shown on the sketch. The sketch should accompany the test results to become part of the test report.

6.2 Humidity requirements

For product qualification, resistance point-to-point, resistance point-to-groundable point and cuff measurements shall be conducted at two humidity conditions according to 4.2 and 4.3. Humidity conditioning for product qualification of the groundable static control garment system is optional and may require a walk-in environmental chamber.

NOTE Laboratory testing has shown that low and moderate humidity conditions do not have a consequential impact on the electrical resistance measurement of a garment in combination with a person.

6.3 Test procedures

6.3.1 General

Subclause 6.3 defines the test methods for measuring the electrical resistance of garments. It includes a resistance point-to-point test and a resistance point-to-groundable point test. The described test procedures may be used for product qualification and acceptance testing. A system test for a garment that provides a path to ground from a person while being worn is also described.

6.3.2 Resistance point-to-point

6.3.2.1 Panel-to-panel

Precondition the test samples according to 6.2 as required. Place the garment on an insulative support surface as described in 5.1.3.1. Place the garment with the front panels opened and laid out as flat as possible (larger garments such as overalls may not allow this completely). Place the insulative sleeve inserts from 5.1.3.2 into each sleeve (including the cuff, if so equipped, or leg cuffs of an overall) of the garment under test. Attach test leads from the resistance measuring apparatus (meter) to the electrodes defined in 5.1.2.1. Place one electrode on a panel of the sample. Place the second electrode on another panel of the same sample. Apply 10 V and observe the reading after 15 s. If the reading is less than $1,0 \times 10^6 \Omega$, record the value. If the reading is greater than or equal to $1,0 \times 10^6 \Omega$, apply 100 V for a minimum of 15 s (or until reading stabilizes) and record the results. Repeat for all electrically interconnected components and panels as well as cuff-to-cuff and sleeve-to-sleeve, making sure that the electrodes are directly above the insulative inserts (see Figure 1, Figure 2 and Figure 3). Repeat for all test samples.

6.3.2.2 Cuff-to-cuff

Some garments may have an insulative exterior and conductive interior of the cuff, or incorporate a wrist strap band or another wrist bonding mechanism or device. Precondition the test samples according to 6.2 as required. Insert the measurement electrodes inside the cuffs or wrist bonding devices. (See Figure 4 and Figure 5). Apply 10 V and observe the reading after 15 s. If the reading is less than $1,0 \times 10^6 \Omega$, record the value. If the reading is greater than or equal to $1,0 \times 10^6 \Omega$, apply 100 V for a minimum of 15 s (or until reading stabilizes) and record the results. Repeat for all test samples.

6.3.2.3 Hanging clamp sleeve-to-sleeve

Precondition the test samples according to 6.2 as required. Hang the garment from each sleeve with electrically isolated clamps (see Figure 6). Place the clamp so that it connects the exterior and the interior of the cuff. The resistance measurement shall be made by applying the voltage lead (positive) to one clamp and attaching the sensor lead (negative) to the other clamp. Apply 10 V and observe the reading after 15 s. If the reading is less than $1,0 \times 10^6 \Omega$, record the value. If the reading is greater than or equal to $1,0 \times 10^6 \Omega$, apply 100 V for a

minimum of 15 s (or until reading stabilizes) and record the results. Repeat for all test samples.

6.3.3 Resistance point-to-groundable point

Precondition the test samples according to 6.2 as required. Place the garment with the front panels opened and laid out as flat as possible (larger garments such as overalls may not allow this completely) on an insulative support surface as described in 5.1.3.1. Use one electrode described in 5.1.2.1 connected to the positive lead of the meter. Place the insulative sleeve insert from 5.1.3.2 into each sleeve of the garment under test. Place the electrode on a cuff (or inside as described in 6.3.2.2), sleeve (directly above the insulative insert) or panel. Connect the negative lead of the meter to the garment groundable point. Apply 10 V and observe the reading after 15 s. If the reading is less than $1,0 \times 10^6 \Omega$, record the value. If the reading is greater than or equal to $1,0 \times 10^6 \Omega$, apply 100 V for a minimum of 15 s (or until reading stabilizes) and record the results. If cuffs are designated as groundable points, measurements shall be made between sleeves and cuffs or between panels and cuffs; see 6.3.2.2 for cuff-to-cuff measurements. Repeat for all panels, sleeves and cuffs and groundable points (see Figure 8 and Figure 9). Repeat for all test samples.

6.3.4 Cuff measurements

IEC 61340-4-6 provides test methods for the evaluation of wrist strap bands and cuffs. These methods may be adapted for use in testing garment cuffs or any wrist strap cuff type grounding mechanism that may be part of a garment and used to bond to the skin of the wearer. The band resistance test procedure described in IEC 61340-4-6 may be used to measure the interior resistance of the garment cuff or wrist strap grounding mechanism (see Figure 10).

NOTE Some garments can be used in conjunction with resistance continuous monitoring systems. Garments of this type can have one cuff that provides the skin contact for personnel grounding, and the other cuff is used for monitoring the electrical continuity between the garment and the wearer. The two cuffs are isolated electrically from each other in this type of garment. The manufacturer can be contacted for assistance in measuring this type of garment.

6.3.5 Groundable static control garment system

This procedure verifies the resistance path from a person wearing the garment, through the body-garment cuff contacts or wrist strap cuff type grounding mechanism to the ground termination point of the garment grounding wire. Testing in a controlled environment is not a requirement of this subclause. Personnel shall wear the garment under test for a minimum of 10 min prior to testing.

This test is conducted with the meter described in 5.1.1.4. This test includes the ground cord and wearer's resistance as part of the total system resistance (see Figure 11 and Figure 12). The test can be performed using a proprietary integrated tester (Figure 12) or resistance meter of similar specification (Figure 11). Connect the grounding point of the garment to the tester using the ground cord. Contact is made to the tester via a push button (on the integrated tester, Figure 12) or a hand held electrode (Figure 11). Apply the test voltage and record the result.

Users of this standard should ensure that garments tested in this procedure meet the grounding requirements at the lowest humidity levels experienced in their facility.

7 Product qualification

Table 1 describes the test required, based on the garment that is being qualified.

Table 1 – Product qualification

Garment type	Qualification testing required
Static control garment	Point-to-point resistance (see 6.3.2)
Groundable static control garment	Point-to-point resistance Point-to-groundable point panel (if applicable) to groundable point (see 6.3.2 and 6.3.3)
Groundable static control garment system	Point to point resistance from panel to panel Point to groundable point panel to groundable point (see 6.3.2, 6.3.3 and integrated wrist strap in accordance with IEC 61340-4-6)

8 Reporting

Record all resistance values. Record the voltage levels, humidity and temperature for each test sample. Record the type of test equipment used and test date. See Annex B for an example of a data collection sheet with sketches.

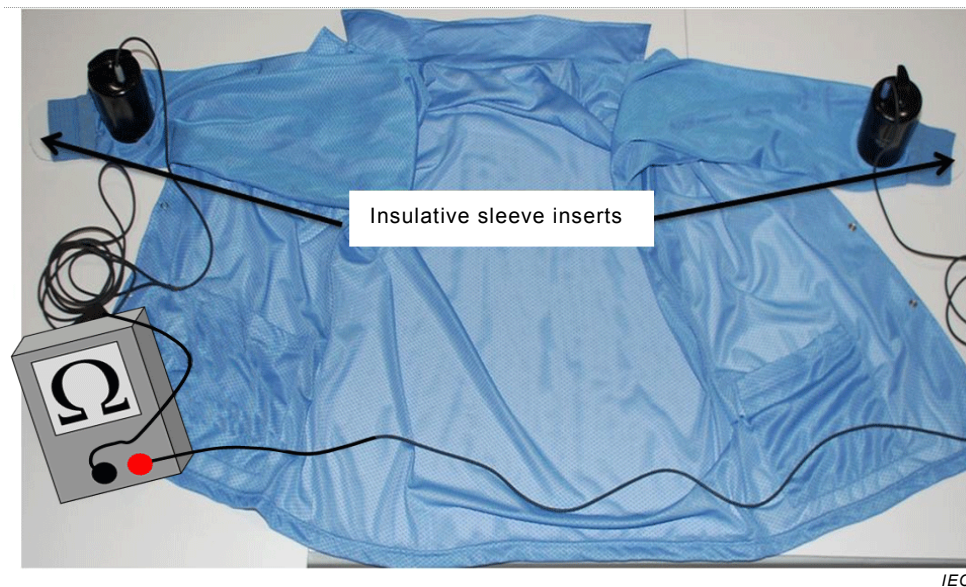

**Figure 1 – Test set-up – Resistance point-to-point
(sleeve-to-sleeve procedure with insulative sleeve inserts)**



Figure 2 – Test set-up – Resistance point-to-point (insulative sleeve inserted into sleeve detail)

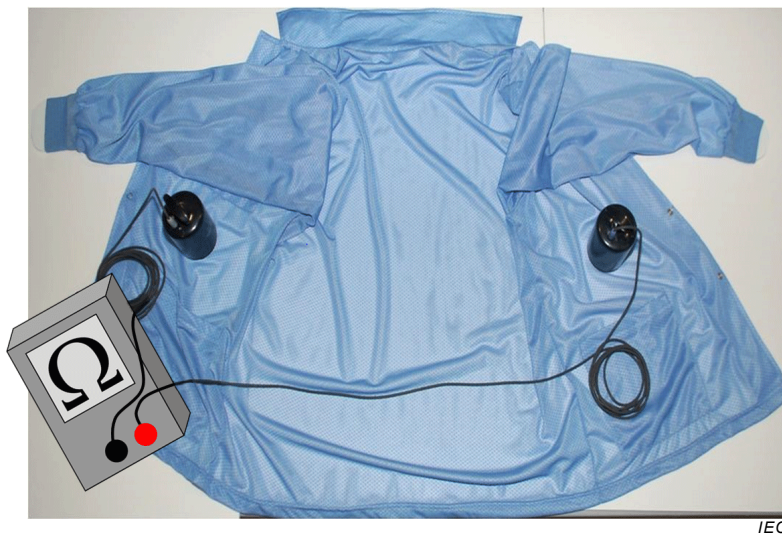

Figure 3 – Test set-up – Resistance point-to-point (panel-to-panel procedure with insulative support surface)



Figure 4 – Test set-up – Resistance point-to-point (cuff-to-cuff procedure with insulative sleeve inserts)



Figure 5 – Test set-up – Resistance point-to-point (electrode inserted into cuff detail)

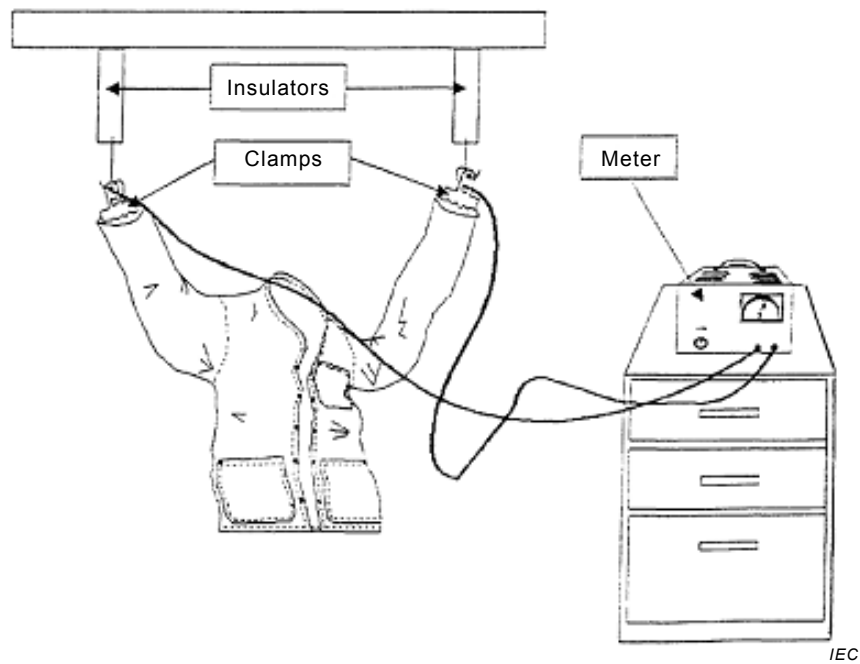

**Figure 6 – Test set-up – Resistance point-to-point
(hanging clamp sleeve-to-sleeve procedure)**

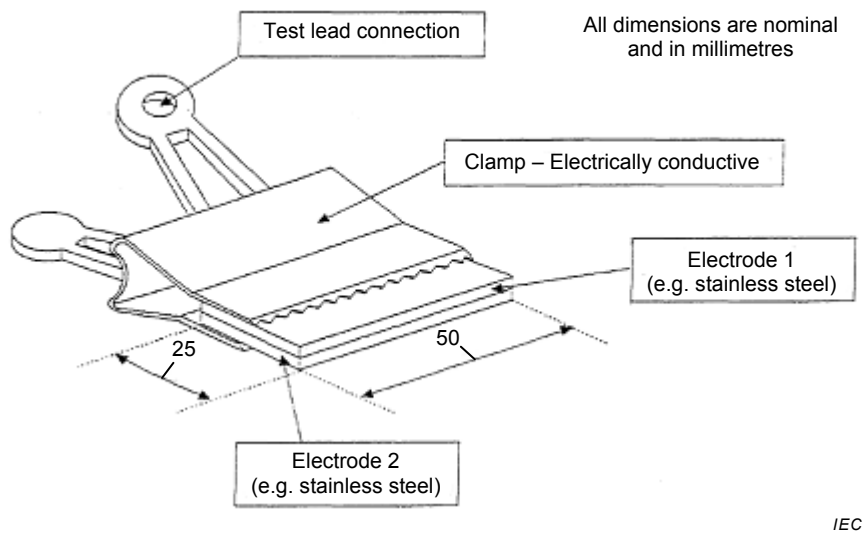

Figure 7 – Clamps/electrodes for hanging garment test

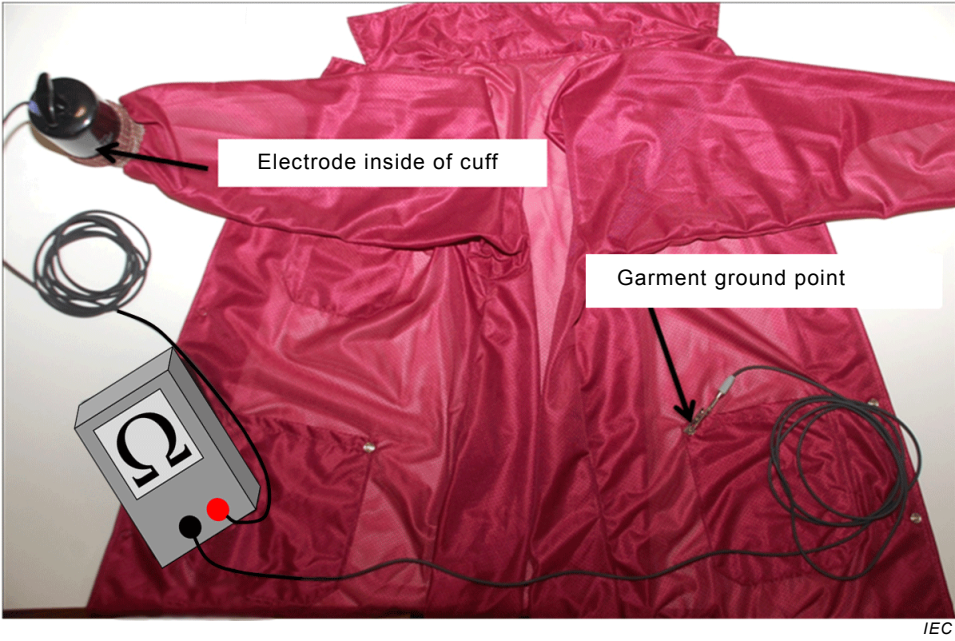

Figure 8 – Test set-up – Resistance point-to-groundable point (cuff-to-groundable-point procedure with insulative sleeve inserts)



Figure 9 – Test set-up – Resistance point-to-groundable point (sleeve-to-groundable-point procedure with insulative sleeve inserts)

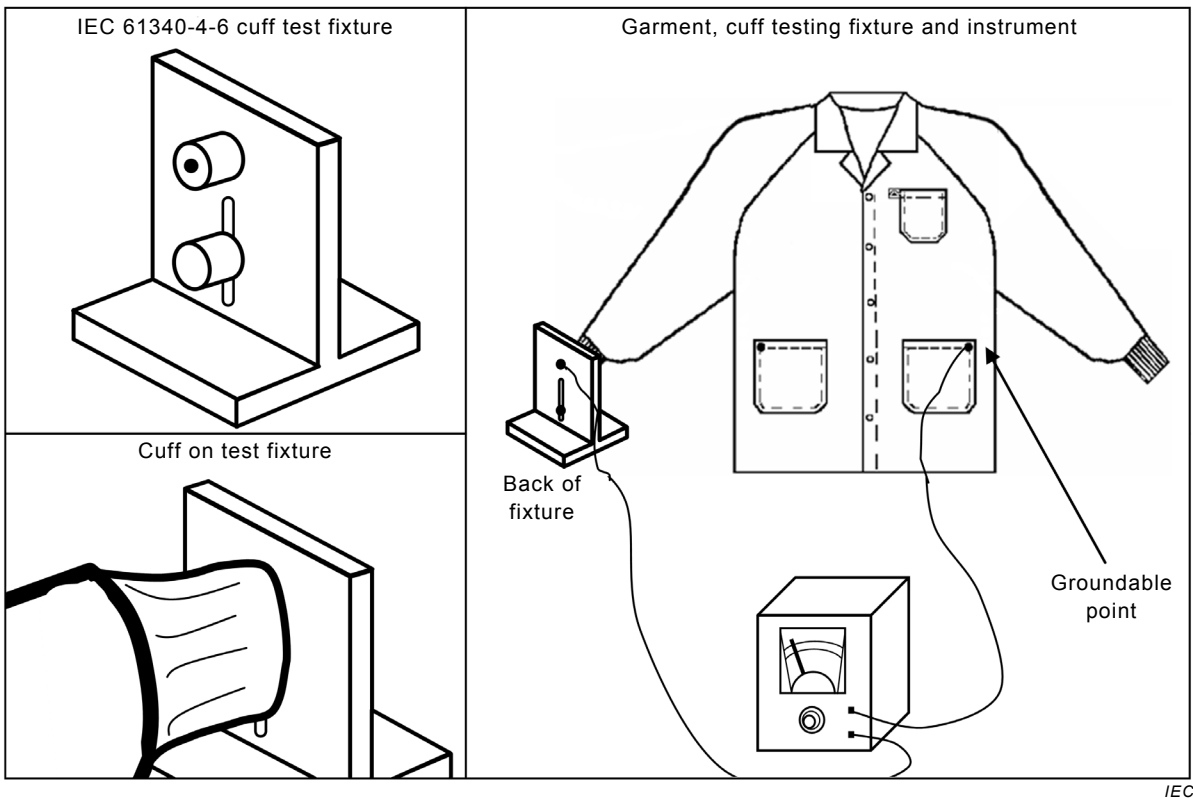
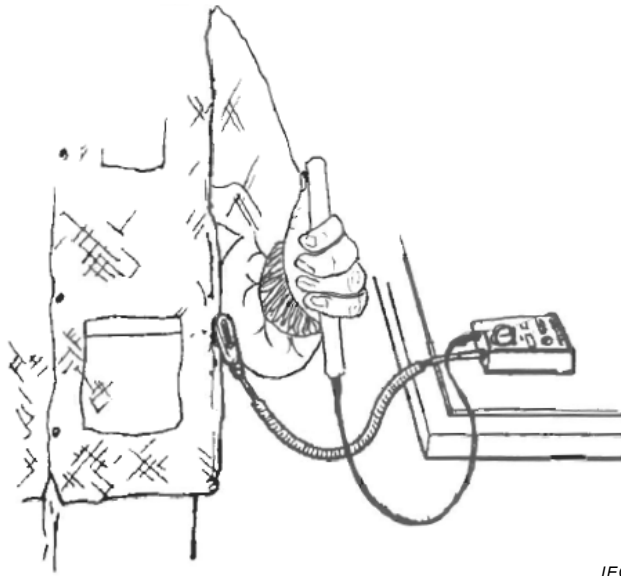
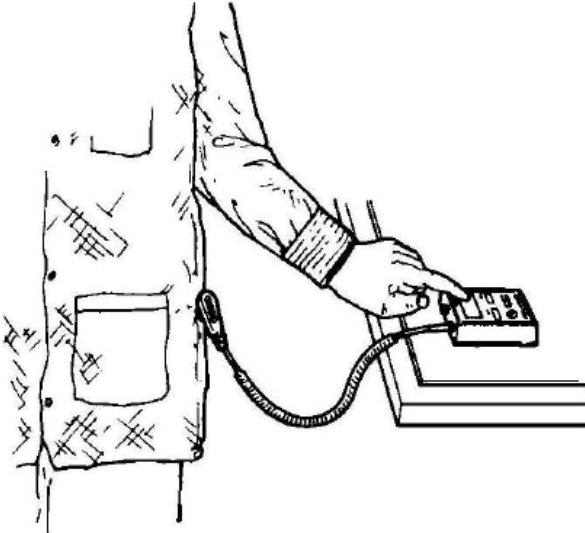

Figure 10 – Groundable garment cuff test



IEC

Figure 11 – Test set-up – Groundable static control garment system resistance (groundable garment in combination with a person using a meter and hand-held electrode)



IEC

Figure 12 – Test set-up – Groundable static control garment system resistance (groundable garment in combination with a person using an integrated tester)

Annex A (informative)

Garment types and resistance values

Table A.1 provides a list of garment types and resistance values.

Table A.1 – Garment types and resistance values

Common industry description/Use of garment system	Garment type	Test procedure	Recommended resistance values
Garments with some electrical field suppression properties	Static control garment	Resistance point to point	$< 1,0 \times 10^{11} \Omega$
Garments with a designated groundable point	Groundable static control garment	Resistance point to point and resistance point to groundable point	$< 1,0 \times 10^9 \Omega$
Garment in continuous electrical path with a person; however, not the primary ground path	Groundable static control garment	Resistance point to point and resistance point to groundable point	$< 1,0 \times 10^9 \Omega$
Grounded with dual paths to ground via continuous monitoring equipment that requires two separate paths to ground	Groundable static control garment system (garment in combination with person)	Resistance point to point and resistance point to groundable point	$< 1,0 \times 10^9 \Omega$
		Integrated wrist strap in accordance with IEC 61340-4-6	$< 3,5 \times 10^7 \Omega$
Grounded through a single wire constant monitor system	Groundable static control garment system (garment in combination with person)	Resistance point to point and resistance point to groundable point	$< 1,0 \times 10^9 \Omega$
		Integrated wrist strap in accordance with IEC 61340-4-6	$< 3,5 \times 10^7 \Omega$
Garment used as primary grounding path for personnel	Groundable static control garment system (Garment in combination with person)	Resistance point to point and resistance point to groundable point	$< 1,0 \times 10^9 \Omega$
		Integrated wrist strap in accordance with IEC 61340-4-6	$< 3,5 \times 10^7 \Omega$

The values in Table A.1 are for information only. For required limits see the latest edition of IEC 61340-5-1 [1]¹.

¹ Numbers in square brackets refer to the Bibliography.

Annex B
(informative)

Data collection sheet (example)

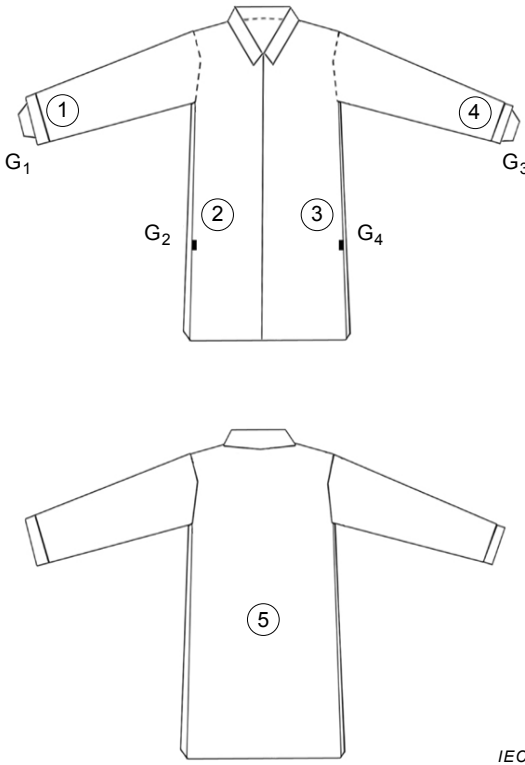
GARMENT EVALUATION TEST Resistive characterization		Test conditions and equipment		Report N°				
		Environment	Moderate	Low				
Manufacturer: _____ Style: _____ Product N°: _____ Procedure: _____ Date: _____		Humidity						
		Temperature						
		Electrode						
		Equipment						
		Voltage						
 <p>G1 & G3: Cuff or wrist strap type grounding mechanism</p> <p>G2 & G4: Ground cord type grounding mechanism</p> <p style="text-align: right;"><i>IEC</i></p>		STATIC CONTROL GARMENT						
		Point-to-point	Sample N°		Sample N°		Sample N°	
			Mod-erate	Low	Mod-erate	Low	Mod-erate	Low
		1 - 2						
		1 - 3						
		1 - 4						
		1 - 5						
		2 - 3						
		2 - 4						
		2 - 5						
		3 - 4						
		3 - 5						
		4 - 5						
		GROUNDABLE STATIC CONTROL GARMENT						
		Point-to-ground	Mod-erate	Low	Mod-erate	Low	Mod-erate	Low
1 - G4								
2 - G4								
3 - G4								
4 - G4								

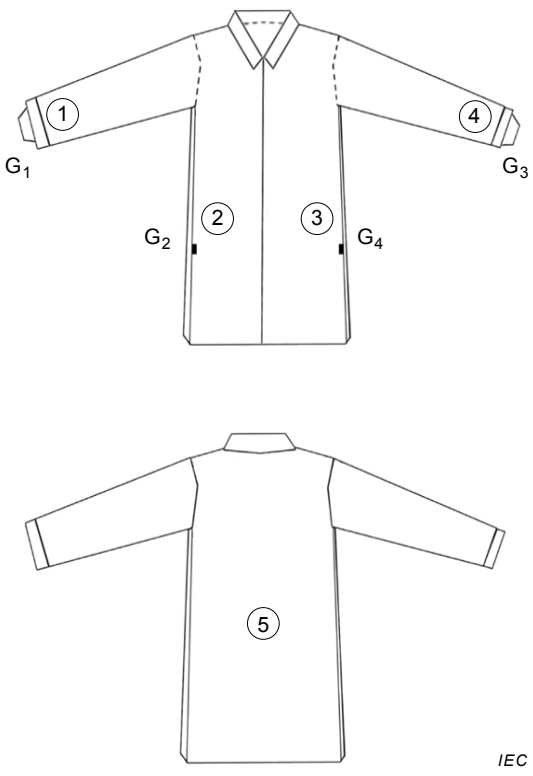
 <p>G1 & G3: Cuff or wrist strap type grounding mechanism</p> <p>G2 & G4: Ground cord type grounding mechanism</p> <p style="text-align: right;"><i>IEC</i></p>	GROUNDABLE STATIC CONTROL GARMENT						
	5 - G4						
5 - G2							
4 - G2							
3 - G2							
2 - G2							
1 - G2							
GROUNDABLE STATIC CONTROL GARMENT SYSTEM							
Cuff to ground	Interior	Exterior	Interior	Exterior	Interior	Exterior	
G1-G2							
G3-G4							
Person to Ground	Right	Left	Right	Left	Right	Left	
TEST CONDITION AMBIENT							
Humidity: _____							
Temperature: _____							
Test equipment: _____							
Comments: _____							
Submitted by: _____							

Bibliography

IEC 61340-5-1, *Electrostatics – Part 5-1: Protection of electronic devices from electrostatic phenomena – General requirements*

British Standards Institution (BSI)

BSI is the national body responsible for preparing British Standards and other standards-related publications, information and services.

BSI is incorporated by Royal Charter. British Standards and other standardization products are published by BSI Standards Limited.

About us

We bring together business, industry, government, consumers, innovators and others to shape their combined experience and expertise into standards-based solutions.

The knowledge embodied in our standards has been carefully assembled in a dependable format and refined through our open consultation process. Organizations of all sizes and across all sectors choose standards to help them achieve their goals.

Information on standards

We can provide you with the knowledge that your organization needs to succeed. Find out more about British Standards by visiting our website at bsigroup.com/standards or contacting our Customer Services team or Knowledge Centre.

Buying standards

You can buy and download PDF versions of BSI publications, including British and adopted European and international standards, through our website at bsigroup.com/shop, where hard copies can also be purchased.

If you need international and foreign standards from other Standards Development Organizations, hard copies can be ordered from our Customer Services team.

Copyright in BSI publications

All the content in BSI publications, including British Standards, is the property of and copyrighted by BSI or some person or entity that owns copyright in the information used (such as the international standardization bodies) and has formally licensed such information to BSI for commercial publication and use.

Save for the provisions below, you may not transfer, share or disseminate any portion of the standard to any other person. You may not adapt, distribute, commercially exploit, or publicly display the standard or any portion thereof in any manner whatsoever without BSI's prior written consent.

Storing and using standards

Standards purchased in soft copy format:

- A British Standard purchased in soft copy format is licensed to a sole named user for personal or internal company use only.
- The standard may be stored on more than 1 device provided that it is accessible by the sole named user only and that only 1 copy is accessed at any one time.
- A single paper copy may be printed for personal or internal company use only.

Standards purchased in hard copy format:

- A British Standard purchased in hard copy format is for personal or internal company use only.
- It may not be further reproduced – in any format – to create an additional copy. This includes scanning of the document.

If you need more than 1 copy of the document, or if you wish to share the document on an internal network, you can save money by choosing a subscription product (see 'Subscriptions').

Reproducing extracts

For permission to reproduce content from BSI publications contact the BSI Copyright & Licensing team.

Subscriptions

Our range of subscription services are designed to make using standards easier for you. For further information on our subscription products go to bsigroup.com/subscriptions.

With **British Standards Online (BSOL)** you'll have instant access to over 55,000 British and adopted European and international standards from your desktop. It's available 24/7 and is refreshed daily so you'll always be up to date.

You can keep in touch with standards developments and receive substantial discounts on the purchase price of standards, both in single copy and subscription format, by becoming a **BSI Subscribing Member**.

PLUS is an updating service exclusive to BSI Subscribing Members. You will automatically receive the latest hard copy of your standards when they're revised or replaced.

To find out more about becoming a BSI Subscribing Member and the benefits of membership, please visit bsigroup.com/shop.

With a **Multi-User Network Licence (MUNL)** you are able to host standards publications on your intranet. Licences can cover as few or as many users as you wish. With updates supplied as soon as they're available, you can be sure your documentation is current. For further information, email subscriptions@bsigroup.com.

Revisions

Our British Standards and other publications are updated by amendment or revision.

We continually improve the quality of our products and services to benefit your business. If you find an inaccuracy or ambiguity within a British Standard or other BSI publication please inform the Knowledge Centre.

Useful Contacts

Customer Services

Tel: +44 345 086 9001

Email (orders): orders@bsigroup.com

Email (enquiries): cservices@bsigroup.com

Subscriptions

Tel: +44 345 086 9001

Email: subscriptions@bsigroup.com

Knowledge Centre

Tel: +44 20 8996 7004

Email: knowledgecentre@bsigroup.com

Copyright & Licensing

Tel: +44 20 8996 7070

Email: copyright@bsigroup.com

BSI Group Headquarters

389 Chiswick High Road London W4 4AL UK