

# Compression and mechanical connectors for power cables for rated voltages up to 36 kV ( $U_m = 42$ kV) —

## Part 1: Test methods and requirements

The European Standard EN 61238-1:2003 has the status of a  
British Standard

ICS 29.060.20

## National foreword

This British Standard is the official English language version of EN 61238-1:2003. It was derived by CENELEC from IEC 61238-1:2003. It supersedes BS 4579-1:1970 and BS 4579-3:1976 which are withdrawn.

The CENELEC common modifications have been implemented at the appropriate places in the text and are indicated by tags (e.g. [C] [C]).

The UK participation in its preparation was entrusted by Technical Committee GEL/20, Electric cables, to Subcommittee GEL/20/11, Cable accessories, which has the responsibility to:

- aid enquirers to understand the text;
- present to the responsible European committee any enquiries on the interpretation, or proposals for change, and keep the UK interests informed;
- monitor related international and European developments and promulgate them in the UK.

A list of organizations represented on this subcommittee can be obtained on request to its secretary.

### Cross-references

The British Standards which implement international or European publications referred to in this document may be found in the *BSI Catalogue* under the section entitled “International Standards Correspondence Index”, or by using the “Search” facility of the *BSI Electronic Catalogue* or of British Standards Online.

This publication does not purport to include all the necessary provisions of a contract. Users are responsible for its correct application.

**Compliance with a British Standard does not of itself confer immunity from legal obligations.**

This British Standard was published under the authority of the Standards Policy and Strategy Committee on 23 October 2003

### Summary of pages

This document comprises a front cover, an inside front cover, the EN title page, pages 2 to 58, an inside back cover and a back cover.

The BSI copyright notice displayed in this document indicates when the document was last issued.

### Amendments issued since publication

Amd. No.	Date	Comments
14855 Corrigendum No. 1	11 November 2003	Correction to pages 5 and 6

© BSI 11 November 2003

ISBN 0 580 42751 X

**Compression and mechanical connectors for power cables  
for rated voltages up to 36 kV ( $U_m = 42$  kV)  
Part 1: Test methods and requirements  
(IEC 61238-1:2003, modified)**

Raccords sertis et à serrage mécanique  
pour câbles d'énergie de tensions  
assignées inférieures ou égales  
à 36 kV ( $U_m = 42$  kV)  
Partie 1: Méthodes et prescriptions  
d'essais  
(CEI 61238-1:2003, modifiée)

Pressverbinder und Schraubverbinder  
für Starkstromkabel für Nennspannungen  
bis einschließlich 36 kV ( $U_m = 42$  kV)  
Teil 1: Prüfverfahren und Anforderungen  
(IEC 61238-1:2003, modifiziert)

This European Standard was approved by CENELEC on 2003-06-01. CENELEC members are bound to comply with the CEN/CENELEC Internal Regulations which stipulate the conditions for giving this European Standard the status of a national standard without any alteration.

Up-to-date lists and bibliographical references concerning such national standards may be obtained on application to the Central Secretariat or to any CENELEC member.

This European Standard exists in three official versions (English, French, German). A version in any other language made by translation under the responsibility of a CENELEC member into its own language and notified to the Central Secretariat has the same status as the official versions.

CENELEC members are the national electrotechnical committees of Austria, Belgium, Czech Republic, Denmark, Finland, France, Germany, Greece, Hungary, Iceland, Ireland, Italy, Lithuania, Luxembourg, Malta, Netherlands, Norway, Portugal, Slovakia, Spain, Sweden, Switzerland and United Kingdom.

## CENELEC

European Committee for Electrotechnical Standardization  
Comité Européen de Normalisation Electrotechnique  
Europäisches Komitee für Elektrotechnische Normung

**Central Secretariat: rue de Stassart 35, B - 1050 Brussels**

## Foreword

The text of document 20/599/FDIS, future edition 2 of IEC 61238-1, prepared by IEC TC 20, Electric cables, was submitted to the IEC-CENELEC parallel vote and was approved by CENELEC as EN 61238-1 on 2003-06-01.

A draft amendment, prepared by the Technical Committee CENELEC TC 20, Electric cables, was submitted to the formal vote and was approved by CENELEC for inclusion into EN 61238-1 on 2003-06-01.

The following dates were fixed:

- latest date by which the EN has to be implemented at national level by publication of an identical national standard or by endorsement (dop) 2004-03-01
- latest date by which the national standards conflicting with the EN have to be withdrawn (dow) 2006-06-01

Annexes designated "normative" are part of the body of the standard.

Annexes designated "informative" are given for information only.

In this standard, annexes A, B, E and ZA are normative and annexes C, D, F, G and H are informative.

Annex ZA has been added by CENELEC.

---

## Endorsement notice

The text of the International Standard IEC 61238-1:2003 was approved by CENELEC as a European Standard with agreed common modifications.

## CONTENTS

INTRODUCTION.....	5
1 Scope and object.....	6
2 Normative references.....	7
3 Definitions.....	7
4 Symbols.....	9
5 General.....	10
5.1 Conductor.....	10
5.2 Connectors and tooling.....	10
5.3 Range of approval.....	10
6 Electrical tests.....	11
6.1 Installation.....	11
6.2 Measurements.....	12
6.3 Heat cycle test.....	13
6.4 Assessment of results.....	16
6.5 Requirements.....	17
7 Mechanical tests.....	17
7.1 Method.....	17
7.2 Requirements.....	17
8 Test report.....	18
Annex A (normative) Equalizers and their preparation.....	25
Annex B (normative) Measurements.....	27
Annex C (informative) Recommendations to improve accuracy of measurement.....	28
Annex D (informative) Determination of the value of the short-circuit-current.....	29
Annex E (normative) Calculation method.....	30
Annex F (informative) Explanation of the calculation method.....	35
Annex G (informative) Explanation of the temperature profile.....	52
Annex H (informative) Explanation of the statistical method of assessing results of tests on electrical connectors.....	54
Annex ZA (normative) Normative references to international publications with their corresponding European publications.....	57
Bibliography.....	58
Figure 1 – Typical test circuit for through connectors and terminal lugs.....	19
Figure 2 – Typical test circuit for branch connectors.....	20
Figure 3 – Typical cases of resistance measurements.....	23
Figure 4 – Second heat cycle.....	24
Figure A.1 – Preparation of equalizers.....	26
Figure E.1 – Graphic example of assessment of an individual connector for Class A.....	32
Figure F.1 – Plot of connector resistance factors and parameter $\delta$ before heat cycle 1.....	40
Figure F.2 – Plot of resistance factors $k^{ij}$ , estimated mean resistance factors $\bar{k}_i$ and estimated overall mean $\bar{k}$ .....	42

Figure F.3 – Plot of estimated mean resistance factors $\bar{k}_i$ , estimated overall mean $\bar{k}$ and parameter $\beta$ .....	43
Figure F.4 – Typical ageing behaviour of an electrical connector ( $k_{lim}$ limiting resistance factor; $t_L$ lifetime) .....	44
Figure F.5 – Plot of the resistance factors, fitted values, estimated intercept and estimated slope.....	45
Figure F.6 – Plot of the fitted values, residuals and parameter $M^i$ .....	46
Figure F.7 – Plot of the pointwise 90 % confidence interval for the mean response and parameter $S^i$ .....	48
Figure F.8 – Plot of parameters $M^i$ , $S^i$ and $D^i$ with regression line.....	49
Table 1 – Minimum elevated current heating time .....	15
Table 2 – Electrical test requirements.....	17
Table 3 – Tensile force for mechanical tests.....	17
Table A.1 – Equalizer dimensions.....	25
Table F.1 – Indices .....	35
Table F.2 – Measured variables .....	35
Table F.3 – Constants .....	35
Table F.4 – Calculated variables .....	36
Table F.5 – Repeatedly measured parameters.....	37
Table F.6 – Number of calculated connector resistance factors $k^{ij}$ for Class A connectors .....	38
Table F.7 – Connector resistance factors $k^{ij}$ for Class A connectors related to the dummy variable $x$ , the initial scatter $\delta$ and the mean scatter $\beta$ .....	41
Table F.8 – Number of resistance factor ratios for connectors of Class A.....	50
Table F.9 – Recorded maximum temperatures during heat cycling.....	51
Table H.1 – Summary of requirements.....	56

## INTRODUCTION

This part of IEC 61238 deals with type tests for compression and mechanical connectors for use on copper or aluminium conductors of power cables for rated voltages up to  $\sqrt{3}$  36 kV ( $U_m = 42$  kV).  $\square$  When a design of connector meets the requirements of this standard, then it is expected that in service:

- a) the resistance of the connection will remain stable;
- b) the temperature of the connector will be of the same order or less than that of the conductor;
- c) the mechanical strength will be fit for the purpose;
- d) if the intended use demands it, application of short-circuit currents will not affect a) and b).

It should be stressed that, although the electrical and mechanical tests specified in this standard are to prove the suitability of connectors for most operating conditions, they do not necessarily apply to situations where a connector may be raised to a high temperature by virtue of connection to highly rated plant, or where the connector is subjected to excessive mechanical vibration or shock or to corrosive conditions. In these instances, the tests in this standard may need to be supplemented by special tests agreed between supplier and purchaser.

# COMPRESSION AND MECHANICAL CONNECTORS FOR POWER CABLES FOR RATED VOLTAGES UP TO $\text{[C]}$ 36 kV ( $U_m = 42 \text{ kV}$ ) $\text{[C]}$ –

## Part 1: Test methods and requirements

### 1 Scope and object

This part of IEC 61238 applies to compression and mechanical connectors for power cables for rated voltages up to  $\text{[C]}$  36 kV ( $U_m = 42 \text{ kV}$ )  $\text{[C]}$ , e.g. buried cables or cables installed in buildings, having

- a) conductors complying with IEC 60228 and IEC 60228A with cross-sectional areas  $10 \text{ mm}^2$  and greater for copper and  $16 \text{ mm}^2$  and greater for aluminium,
- b) a maximum continuous conductor temperature not exceeding  $90 \text{ }^\circ\text{C}$ .

This standard is not applicable to connectors for overhead conductors, which are designed for special mechanical requirements, or to separable connectors with a sliding contact or multi-core connectors (i.e. ring connectors).

Although it is not possible to define precisely the service conditions for all applications, two broad classes of connectors have been identified.

#### *Class A*

These are connectors intended for electricity distribution or industrial networks in which they can be subjected to short-circuits of relatively high intensity and duration. As a consequence, Class A connectors are suitable for the majority of applications.

#### *Class B*

These are connectors for networks in which overloads or short-circuits are rapidly cleared by the installed protective devices, e.g. fast-acting fuses.

Depending on the application, the connectors are subjected to the following tests:

*Class A:* heat cycle and short-circuit tests;

*Class B:* heat cycle tests only.

The object of this standard is to define the type test methods and requirements, which apply to compression and mechanical connectors for power cables with copper or aluminium conductors.

Formerly, approval for such products has been achieved on the basis of national standards and specifications and/or the demonstration of satisfactory service performance. The publication of this IEC standard does not invalidate existing approvals. However, products approved according to these earlier standards or specifications cannot claim approval to this IEC standard unless specifically tested to it.



After they have been made, these tests need not be repeated unless changes are made in the connector material, design or manufacturing process which might affect the performance characteristics.

## 2 Normative references

The following referenced documents are indispensable for the application of this document. For dated references, only the edition cited applies. For undated references, the latest edition of the referenced document (including any amendments) applies.

IEC 60050(461):1984, *International Electrotechnical Vocabulary (IEV) – Chapter 461: Electric cables*  
Amendment 1 (1993)

IEC 60228:1978, *Conductors of insulated cables*

IEC 60228A:1982, First supplement – *Conductors of insulated cables – Guide to the dimensional limits of circular conductors*

IEC 60493-1:1974, *Guide for the statistical analysis of ageing test data – Part 1: Methods based on mean values of normally distributed test results*

## 3 Definitions

For the purposes of part of IEC 61238, the following definitions apply. Where possible, the definitions used are in accordance with IEC 60050(461).

### 3.1

#### **connector (of cables)**

metallic device for connecting a conductor to an equipment terminal or for connecting two or more conductors to each other

[IEV 461-17-03, modified]

### 3.2

#### **through connector**

metallic device for connecting two consecutive lengths of conductor

[IEV 461-17-04]

### 3.3

#### **branch connector**

metallic device for connecting a branch conductor to a main conductor at an intermediate point on the latter

[IEV 461-17-05]

### 3.4

#### **(terminal) lug**

metallic device to connect a cable conductor to other electrical equipment

[IEV 461-17-01]

**3.5****palm (of terminal lug)**

part of a terminal lug used to make the connection to electrical equipment

[IEV 461-17-07]

**3.6****barrel (of terminal lug, of connector, etc.)**

part of a device into which the conductor to be connected is introduced

[IEV 461-17-06]

**3.7****reference conductor**

length of unjointed bare conductor or conductor with the insulation removed, which is included in the test loop and which enables the reference temperature and reference resistance to be determined

**3.8****equalizer**

arrangement used in the test loop to ensure a point of equipotential in a stranded conductor

**3.9****compression jointing**

method of securing a connector to a conductor by using a special tool to produce permanent deformation of the connector and the conductor

**3.10****mechanical jointing**

method of securing a connector to a conductor, for example by means of a bolt or screw acting on the latter or by alternative methods

**3.11****median connector**

connector which during the first heat cycle records the third highest temperature of the six connectors in the test loop

**3.12****insulation piercing connector (IPC)**

connector in which electrical contact with the conductor is made by metallic protrusions which pierce the insulation of the cable core

[IEV 461-11-08]

NOTE The abbreviation IPC will be used throughout the standard.

## 4 Symbols

$A$	nominal cross-sectional area of the conductor
$D$	change in the resistance factor of the connector
$I$	direct current flowing through a connection during resistance measurement
$I_{\text{rms}}$	equivalent r.m.s. short-circuit current
$I_{\text{N}}$	alternating current necessary to maintain the reference conductor at its equilibrium temperature
$I_{\text{r}}$	direct current flowing through the reference conductor/conductors during resistance measurement
$k$	connector resistance factor: ratio of the resistance of a connector to that of the resistance of the equivalent length of the reference conductor
$l_{\text{a}}, l_{\text{b}}, l_{\text{j}}$	lengths of the connector assembly associated with the measurement points after jointing
$l_{\text{r}}$	length of the reference conductor between measurement points
$t_1$	heating time
$t_2$	time necessary for the connectors and the reference conductor to cool to a value equal to or less than 35 °C
$U$	potential difference between measurement points when current $I$ is flowing
$U_{\text{r}}$	potential difference between measuring points on a reference conductor when current $I_{\text{r}}$ is flowing
$\alpha$	temperature coefficient of resistance at 20 °C
$\beta$	mean scatter of the connector resistance factors
$\delta$	initial scatter of the connector resistance factors
$\lambda$	resistance factor ratio: change in the resistance factor of the connector, relative to its initial resistance factor
$\theta$	temperature of a connector
$\theta_{\text{max}}$	maximum temperature recorded on a connector over the total period of test
$\theta_{\text{R}}$	temperature of the reference conductor determined in the first heat cycle
$\theta_{\text{ref}}$	temperature of the reference conductor at the moment of measuring $\theta_{\text{max}}$

NOTE Suffixes may be used to indicate values for the individual connector, see Annex F.

## 5 General

### 5.1 Conductor

The following information shall be recorded in the test report:

- conductor material;
- nominal cross-sectional area, dimensions and shape. It is recommended that the actual cross-sectional area should also be given;
- type of conductor, i.e. solid or stranded. In the case of stranded conductors, details of conductor constructions shall be given when known, or can be determined by inspection, e.g:
  - compacted;
  - non-compacted;
  - flexible (Class 5 and 6, according to IEC 60228);
  - number and arrangement of strands;
  - type of plating, if applicable;
  - type of impregnation, water blocking, etc., if applicable;
- approximate indication of hardness, e.g. annealed, half-hard, hard;
- in the case of insulation-piercing connectors, material and thickness of insulation.

### 5.2 Connectors and tooling

The following information shall be recorded in the test report:

- the assembly technique that is to be used;
- tooling, dies and necessary setting;
- bolts, nuts, washers, torque, etc.;
- preparation of contact surfaces, if applicable;
- type, reference number and any other identification of the connector;
- in the case of insulation piercing connectors, type of insulation and installation temperature.

### 5.3 Range of approval

In general, tests made on one type of connector/conductor combination apply to that arrangement only. However, to limit the number of tests the following is permitted:

- a connector which can be used on stranded round conductors or on stranded sector-shaped conductors which have been rounded, is approved for both types if satisfactory results are obtained on a compacted round conductor;
- a connector which covers a range of cross-sectional areas shall be approved, if satisfactory results are obtained on the smallest and the largest cross-sectional area (see Note 2 below);
- if a connector is a through connector for two conductors of different cross-sectional areas, shapes, or materials, and if the technique and the connector barrels used have already been tested separately for each cross-sectional area, no additional test is necessary. If not, and if it is required for bimetallic through connectors, additional tests shall be made using the conductor having the highest temperature of the two conductors, as reference conductor;

- if a manufacturer can clearly demonstrate that common and relevant connector design criteria were used for a family of connectors, conformity to this standard is achieved by successfully testing the largest, the smallest and two intermediate connector sizes;
 

Exception no.1: for a family of connectors consisting of five sizes, only the largest connector, the smallest connector, and one connector of a representative intermediate size need to be tested.

Exception no.2: for a family of connectors consisting of four sizes or less, only the largest connector and the smallest connector need to be tested.
- in the case of range-taking connectors, the maximum and minimum conductor cross-sectional area for the selected connectors shall be tested;
- satisfactory test results on insulation piercing connectors tested on PVC insulation at lower temperatures for heat cycles and for short-circuits shall give approval of such connectors for PVC insulation only;
- satisfactory test results of a connector on dry conductor shall give approval for its use on a conductor of the same type from an impregnated paper insulated cable;
- for connectors where one or both sides are designed for a range of cross-sectional areas, and a common clamping or crimping arrangement serves for the connection of the different cross-sectional areas, then mechanical tests on conductors with the largest and smallest cross-sectional areas shall be carried out according to Clause 7.

NOTE 1 Examples of relevant design criteria include

- compression reduction,
- number of contact screws or crimps,
- force per unit area of contact screw or crimp,
- ratio of amount of material of connector to that of conductor.

NOTE 2 Different types of water blocking may affect the performance.

## 6 Electrical tests

### 6.1 Installation

All conductors of the same cross-sectional area in the test loop shall be taken from the same continuous core.

For each series of tests, six connectors shall be fitted in accordance with the manufacturer's instructions, on a bare conductor or on a conductor that has had the insulation removed before assembly, to form a test loop together with the corresponding reference conductor.

For stranded conductors, potential between the strands at measuring points can cause errors in measuring electrical resistance. Equalizers (see Annex A) shall be used to overcome this problem and to ensure uniform current distribution in the reference conductor and between connectors at the equalizer points.

In the case of insulation piercing connectors, the insulation shall be retained on the conductor under the connector and for a distance of at least 100 mm outside the connector. Reference conductor(s) with the insulation retained shall also be included in the test loop. If the connector is to be tested according to Class B, there is no need for bare reference conductors.

The test loop shall be installed in a location where the air is calm. The ambient temperature of the test location shall be between 15 °C and 30 °C.

For assembly of the IPC, the temperature shall be  $(23 \pm 3)$  °C.

In the case of solid conductors, the potential measuring points shall be as close as possible to the connector in order to reduce  $l_a$  and  $l_b$  close to zero.

The test loop may be of any shape provided that it is arranged in such a way that there is no adverse affect from the floor, walls and ceiling.

To permit the short-circuit tests (Class A connectors only) to be made easily, the loop can be made dismantlable. In this case, the technology of the sectioning connections shall be such that they do not influence the measurements, particularly from the point of view of temperature.

Retightening of bolts or screws of the connectors under test is not permitted.

### 6.1.1 Through connectors and terminal lugs

The test loop is shown in Figure 1, which indicates the dimensions that shall be used.

Where terminal lugs are to be tested, the palms shall be bolted to linking bars in accordance with the manufacturer's instructions. These linking bars shall, at the point of connection, be of the same dimensions and thickness as the palm, and also of the same material.

It may be necessary to adjust the thermal characteristics of the linking bar outside the point of connection, to achieve the temperatures specified in 6.3. As an alternative to linking bars, tests can be made on terminal lugs with palm connected direct to palm. In case of disagreement, the method with linking bars shall be used.

If however it is requested that the terminal lug test includes an evaluation of the performance of the bolted palm when connected to a plant terminal, then linking bar ends, or an intermediate piece, shall be used of a material, size and surface coating agreed between the parties.

### 6.1.2 Branch connectors

When the branch connector is intended for a branch cross-sectional area equal to the main, or a cross-sectional area immediately above or below the main, it is treated as a through connector between the main and the branch, and the test method for through connectors is applicable. In other cases, the test loop shall be as shown in Figure 2. Where a type of connector makes it necessary for the main conductor to be cut, that part of the connector which acts as a through connector, shall also be tested as for through connectors.

## 6.2 Measurements

### 6.2.1 Electrical resistance measurements

Measurements of electrical resistance shall be made at stages throughout the test as specified in 6.3.

These measurements of resistance shall be made under steady temperature conditions of both the test loop and test location. The ambient temperature shall be between 15 °C and 30 °C.

The recommended method is to pass a direct current of up to 10 % of the heat cycling current, through the connectors and the reference conductor, without increasing the temperature and to measure the potential difference between specific potential points. The ratio of potential difference and direct current is the resistance between those points.

NOTE To improve the accuracy of the resistance measurement, it is recommended that the same direct current is used throughout the test programme.

For branch conductors assembled in accordance with Figure 2, the whole of the measuring current shall flow through that part of the connector whose potential difference is being measured. Switches or disconnect points may be provided for this purpose.

Thermoelectric voltages may affect the accuracy of low resistance measurements (of the order of 10  $\mu\Omega$ ). If this is suspected, two resistance measurements shall be taken with the direct measuring current reversed between readings. The mean of the two readings is then the actual resistance of the sample.

The potential points shall be as indicated in Figure 3, and Annex B, and the various lengths shown shall also be measured to enable the actual connector resistances to be determined. The temperature of connector and reference conductor shall be recorded when resistance measurements are made. For direct comparison, the resistance values shall be corrected to 20 °C. Information on the recommended method is also given in Annex B. Temperature measurements at these locations shall be made during the heat cycling test.

*Indirect resistance readings:*

- voltage measurements shall have an accuracy within  $\pm 0,5$  % or  $\pm 10$   $\mu\text{V}$ , whichever is the greater;
- current measurements shall have an accuracy within  $\pm 0,5$  % or  $\pm 0,1$  A, whichever is the greater.

*Direct resistance readings:*

Resistance measurements shall have an accuracy within  $\pm 1$  % or  $\pm 0,5$   $\mu\Omega$ , whichever is the greater when the instrument is calibrated against a certified standard resistance.

## 6.2.2 Temperature measurements

The temperature measurements shall be made at stages throughout the test, as specified in 6.3.

Temperatures of both connectors and reference conductors shall be measured at the points indicated in Figure 3. The recommended method of temperature measurement is to use thermocouples. Temperature readings shall have an accuracy within  $\pm 2$  K.

## 6.3 Heat cycle test

The heat cycling test shall be made with alternating current.

### 6.3.1 First heat cycle

The object of the first heat cycle is to determine the reference conductor temperature to be used for subsequent cycles and also to identify the median connector.

#### a) Non-IPC through connectors and terminal lugs

Current is circulated in the test loop, bringing the reference conductor to 120 °C at equilibrium.

Equilibrium is defined as the moment when the reference conductor and the connectors do not vary in temperature by more than  $\pm 2$  K for 15 min.

If the temperature of the median connector (see 3.11) is equal to or greater than  $100\text{ }^{\circ}\text{C}$ , the reference conductor temperature for subsequent heat cycles shall be deemed to be  $120\text{ }^{\circ}\text{C}$ . If not, then the current shall be increased until the median connector temperature reaches  $100\text{ }^{\circ}\text{C}$  at equilibrium, subject to the reference conductor temperature not exceeding  $140\text{ }^{\circ}\text{C}$ . If the temperature of the median connector does not reach  $100\text{ }^{\circ}\text{C}$ , even with a reference conductor temperature of  $140\text{ }^{\circ}\text{C}$ , the test shall be continued at that temperature. The measured reference conductor temperature  $\theta_R$  shall then be used for subsequent heat cycles ( $120\text{ }^{\circ}\text{C} \leq \theta_R \leq 140\text{ }^{\circ}\text{C}$ ). The current  $I_N$  at equilibrium temperature shall be recorded in the test report.

NOTE 1 Where linking bars are used for terminal lugs, the temperature at the midpoint of the bar linking the palms should also be measured. This temperature should be equal to the temperature of the reference conductor  $\theta_R$ , with a tolerance of  $\pm 5$  K.

#### b) Non-IPC branch connectors

Where it is necessary to use the circuit shown in Figure 2, current shall be circulated in the test loop, bringing the main reference conductor and the three branch reference conductors to  $120\text{ }^{\circ}\text{C}$  at equilibrium. To achieve this, the currents in the three branches shall be adjusted by current injection or impedance control. If the median connector temperature (see 3.11) is then equal to or greater than  $100\text{ }^{\circ}\text{C}$ , the reference conductor temperature for subsequent heat cycles shall be deemed to be  $120\text{ }^{\circ}\text{C}$ . If not, then the current shall be increased in the loop until the median connector temperature reaches  $100\text{ }^{\circ}\text{C}$  at equilibrium, provided the reference conductors do not exceed  $140\text{ }^{\circ}\text{C}$ . It may be necessary at this stage, and also at intervals throughout the test, to adjust the current in an individual branch so as to ensure that each branch reference temperature is the same as the main reference temperature. The measured reference conductor temperature  $\theta_R$  on the main and branch conductors, shall then be used for subsequent heat cycles ( $120\text{ }^{\circ}\text{C} \leq \theta_R \leq 140\text{ }^{\circ}\text{C}$ ). The current(s)  $I_N$  at equilibrium temperature in the main and branch conductors shall be recorded in the test report.

#### c) IPC

For tests of IPCs, the same test loop as in Figure 1 or 2 shall be used except that the insulated reference conductor(s) is (are) added in the circuit. During cycling, the temperature on the median connector shall be modified to be 10 K higher than the maximum conductor temperature in normal operation for which these type of connectors are intended. However, the circulated current shall be limited so that the temperature of the insulated reference conductor at equilibrium is not more than 10 K to 15 K above the maximum conductor temperature in normal operation. In the case of branch connectors, it may be necessary at intervals throughout the test, to adjust the current in an individual branch so as to ensure that each branch reference temperature is the same as the main reference temperature. The current(s)  $I_N$  at equilibrium temperature in the main and possible branch conductors shall be recorded in the test report.

NOTE 2 If a connector is used in an application where considerably higher temperatures are reached than the maximum conductor temperature in normal operation, additional tests at higher temperature of the test loop may be made, after agreement between manufacturer and user. The additional increase in temperature of the test loop should be achieved by the application of thermal insulation.

### 6.3.2 Second heat cycle

The object of this second heat cycle is to determine the heat cycle duration and temperature profile which will be used on the test loop for all subsequent heat cycles. Current is circulated in the loop until the main reference conductor temperature reaches the value  $\theta_R$  determined in 6.3.1, with a tolerance of  ${}^+6_0$  K and the median connector temperature is stable within a band of 2 K over a 10 min period.



An elevated current may be used to reduce the heating period. The duration of this elevated current is given in Table 1. The current shall thereafter be decreased or regulated to a mean value of the current close to  $I_N$  to ensure stable conditions during the median-conductor control period. It may be necessary to use more than one cycle to determine the second heat cycle.

The reference conductor temperature shall be the control parameter, in order to keep the temperature profile during the heat cycle test. In this way, the fluctuation of the ambient temperature will not affect the temperature profile of the reference conductor.

**Table 1 – Minimum elevated current heating time**

<b>Nominal conductor cross-sectional area, <math>A</math></b>	mm <sup>2</sup>	Al	$16 \leq A \leq 50$	$50 < A \leq 150$	$150 < A \leq 630$	$A > 630$
		Cu	$10 \leq A \leq 35$	$35 < A \leq 95$	$95 < A \leq 400$	$A > 400$
<b>Time</b>	min		5	10	15	20

The reference temperature time ( $t_1$ ) heating profile, see Figure 4, determined in this way shall be recorded and used for all subsequent cycles.

After the period  $t_1$ , follows a period  $t_2$  of cooling to bring the temperature of all connectors and the reference conductor to a value  $\leq 35$  °C.

It may be necessary in subsequent heat cycles to adjust  $t_2$  to ensure that the temperature conditions are reached.

If accelerated cooling is used, it shall act on the whole of the loop, and use air within ambient temperature limits.

The total period  $t_1 + t_2$  constitutes a heat cycle (see Figure 4).

### 6.3.3 Subsequent heat cycles

A total of 1000 heat cycles (as defined in 6.3.2) shall be made. After the cooling period of the cycles indicated below, the resistance and temperature of each connector and each reference conductor shall be recorded as indicated in 6.2. The maximum temperature of each connector during the cycle just prior to or following the resistance measurements shall also be recorded.

Measurements shall be made at the following cycles:

<i>Class A</i>	<i>Class B</i>
0 (before the first heat cycle, see 6.3.1)	0 (before the first heat cycle, see 6.3.1)
200, before short-circuit	250
200, after short-circuit	then every 75 cycles
250	(in total 12 measurements)
Then every 75 cycles	
(in total 14 measurements)	

A tolerance of  $\pm 10$  cycles may be used.

### 6.3.4 Short-circuit tests (for Class A connectors only)

Six short-circuits are applied after the 200<sup>th</sup> heat cycle.

The short-circuit current level shall be such that it raises the bare reference conductors from a temperature of  $\leq 35$  °C to a temperature between 250 °C and 270 °C.

However, for IPC connectors the short-circuit current shall be limited so that the temperature of the insulated reference conductor does not exceed the maximum permissible temperature of the insulation.

NOTE 1 The short-circuit current may be calculated according to Clause 3 of IEC 60949 and may be determined in accordance with Annex D of this standard as a method for selecting the current needed for a certain temperature rise, providing the actual conductor cross-sectional area is verified.

The maximum temperature, time and approximate current, or the actual current and time, used for the short-circuit test, shall be recorded and stated in the test report.

The duration of the short-circuit current shall be  $(1_{-0,1}^{+0,5})$  s with a maximum current of 25 kA.

If the required short-circuit current exceeds this value a longer duration  $\leq 5$  s with a current between 25 kA and 45 kA shall be used.

After each short-circuit, the test loop shall be cooled to a temperature  $\leq 35$  °C.

NOTE 2 For large cross-sectional areas, pre-heating up to 90 °C may be used. However, for cross-sectional areas exceeding 630 mm<sup>2</sup> copper or 1000 mm<sup>2</sup> aluminium, the above parameters (45 kA and 5 s) are insufficient to reach 250 °C.

As stated in 6.1, the test loop may be dismantled for these tests. Since the short-circuit test is intended to reproduce the thermal effects of high currents only, the recommended method is to use a concentric return conductor in order to reduce the electro-dynamic forces. The test arrangements shall be recorded.

NOTE 3 It should be noted that bending or vibrations during assembly, transport and handling may give rise to mechanical forces which affect the contact resistance of the test objects and should thus be avoided. Where tests are required to reproduce, e.g. forces that occur on terminal lugs bolted to a terminal plant, then the mechanical arrangement of the test loop should be agreed between the parties concerned.

NOTE 4 For special applications, other short-circuit conditions may be adopted.

NOTE 5 For branch connectors, the reference conductor is that associated with the branch.

## 6.4 Assessment of results

An individual connector resistance factor  $k$  enables a common method of connector assessment to be made over the range of conductor cross-sectional areas applicable to this standard. The parameters listed below are calculated (see Annex E).

- a) The connector resistance factor  $k$  shall be calculated according to Clause E.2, for each of the six connectors at all the measurement intervals listed in 6.3.3.
- b) The initial scatter  $\delta$ , between the six initial values of  $k$ , measured at heat cycle 0, shall be calculated according to Clause E.3.
- c) The mean scatter  $\beta$ , between the six values of  $k$ , averaged over the last 11 measurement intervals, shall be calculated according to Clause E.4.
- d) The change in resistance factor  $D$  for each of the six connectors shall be calculated according to Clause E.5.  $D$  is the change in the value of  $k$  taken over the last 11 measurement intervals, calculated as a fraction of the mean value of  $k$  in this interval.
- e) The resistance factor ratio  $\lambda$  shall be calculated according to Clause E.6.
- f) The maximum temperature  $\theta_{\max}$  on each connector shall be recorded according to Clause E.7.

## 6.5 Requirements

The six connectors shall satisfy the requirements shown in Table 2. If one connector out of the six does not satisfy one or more of the requirements, a re-test may be carried out. In this event, all six new connectors shall satisfy the requirements.

If more than one connector out of the six do not satisfy one or more of the requirements, no re-test is permitted and the type of connector shall be deemed as not conforming to this standard.

**Table 2 – Electrical test requirements**

Parameter	Designation	Text reference	Maximum value
Initial scatter	$\delta$	E.3	0,30
Mean scatter	$\beta$	E.4	0,30
Change in resistance factor	$D$	E.5	0,15
Resistance factor ratio	$\lambda$	E.6	2,0
Maximum temperature	$\theta_{\max}$	E.7	$\theta_{\text{ref}}$

NOTE Values given in this table are based on experience.

## 7 Mechanical tests

The purpose of these tests is to ensure an acceptable mechanical strength for the connections to the conductors of power cables.

NOTE The pull-out force does not give any reliable indication of the electrical quality of the connector.

### 7.1 Method

The test shall be made on three additional connectors identical to those used for the electrical test. The connectors are fitted as for the electrical test of 6.1. The conductor lengths, between connectors or between connector and tensile test machine jaws, shall be  $\geq 500$  mm. The rate of application of the load shall not exceed 10 N per square millimetre of cross-sectional area and per second up to the value in Table 3, which is then maintained for 1 min.

If the connector is tested electrically for conductors with a different cross-sectional area, the different connectors shall be tested individually, in accordance with Table 3.

**Table 3 – Tensile force for mechanical tests**

Conductor material	Tensile force N
Aluminium	$40 \times A^a$ ; maximum 20000
Copper	$60 \times A^a$ ; maximum 20000

<sup>a</sup>  $A$  = nominal cross-sectional area (mm<sup>2</sup>).

### 7.2 Requirements

No slipping shall occur during the last minute of the test.

## **8 Test report**

The test report shall include the following information:

- connector class (see Clause 1);
- conductor used (see 5.1);
- connector and tooling (see 5.2);
- installation (for example see 6.1.1);
- current at equilibrium temperature (see 6.3.1);
- for Class A, the short-circuit parameters (see 6.3.4);
- electrical test results;
- mechanical test results.

NOTE It is advisable to show a graph of the connector resistance factor  $k$  versus the cycle number, a graph of temperature versus the cycle number and also a graph of the temperature profile.

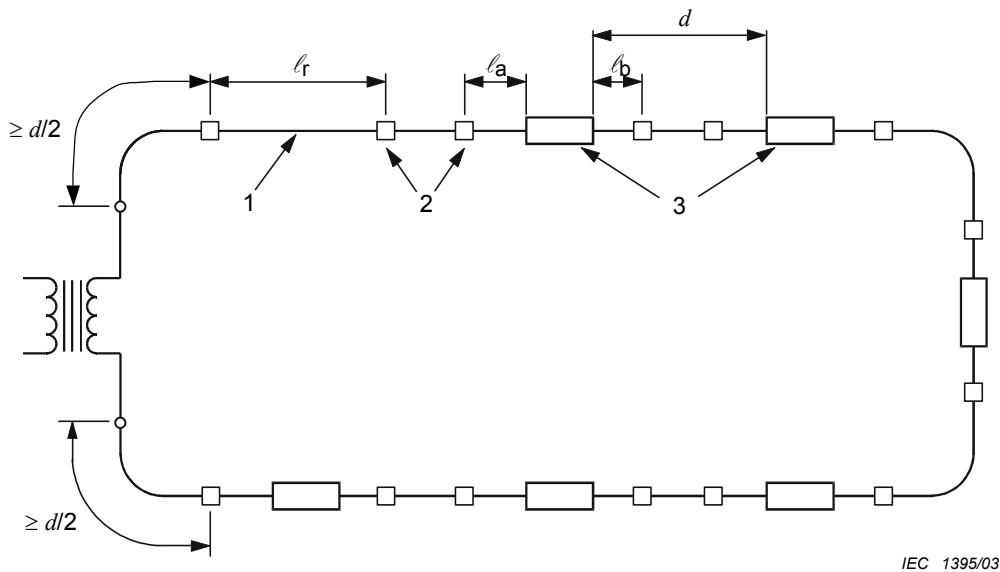

Figure 1a – Through connectors

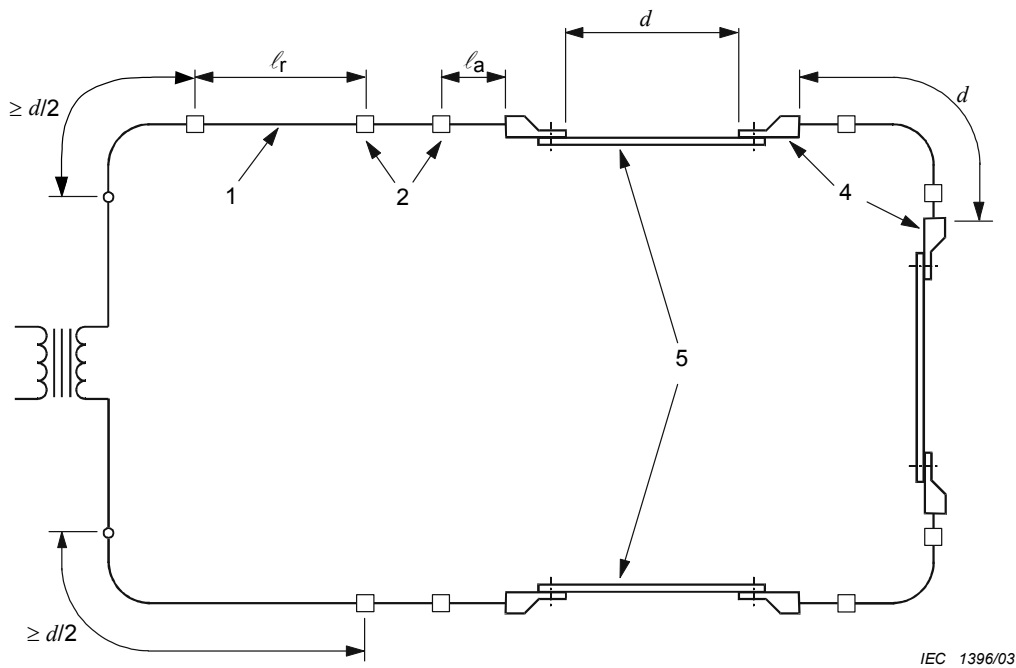

Figure 1b – Terminal lugs

where

$d \geq 80 \sqrt{A}$  or 500 mm, whichever is the greater

$A$  is the corresponding conductor cross-sectional area, in  $\text{mm}^2$

$\ell_r \geq \ell_a + \ell_b + \ell_j$  (for  $\ell_j$ , see Figure 3)

For stranded conductors:

$\ell_a, \ell_b \approx 15 \sqrt{A}$  or 150 mm, whichever is the greater

**Key**

- 1 reference conductor
- 2 equalizers (for stranded conductors)
- 3 through connectors
- 4 terminal lugs
- 5 linking bars

Figure 1 – Typical test circuit for through connectors and terminal lugs

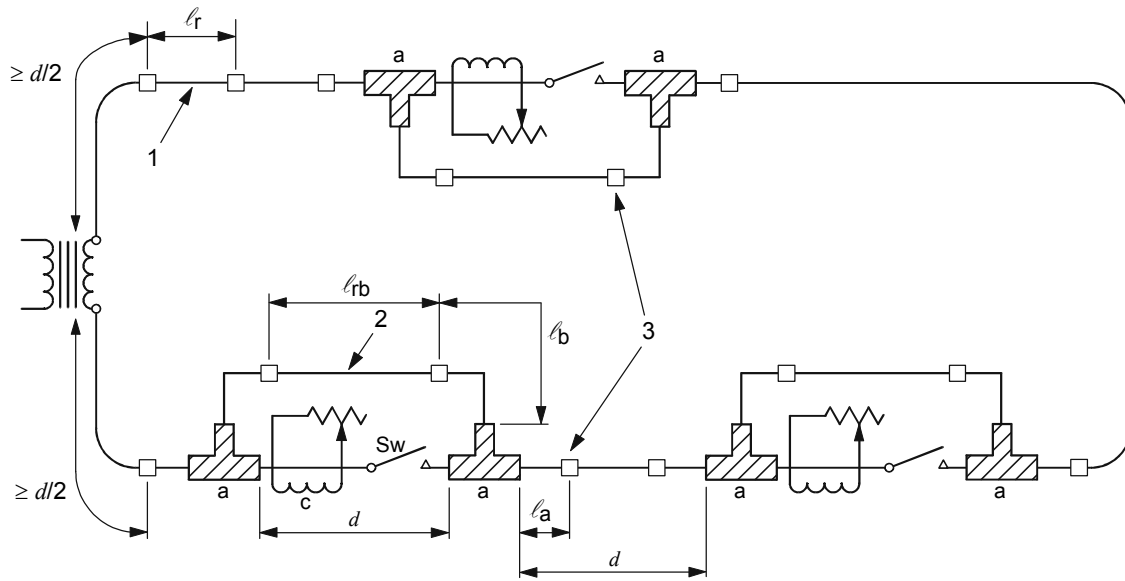

IEC 1397/03

where

$d \geq 80 \sqrt{A}$  or 500 mm, whichever is the greater

$A$  is the main conductor sectional area, in  $\text{mm}^2$

$l_r, l_{rb} \geq d$

For stranded conductors:

$l_a, l_b \approx 15 \sqrt{A}$  or 150 mm, whichever is the greater

**Key**

- 1 main reference conductor
- 2 branch reference conductor
- 3 equalizer (for stranded conductors)
- a branch connector
- c current control;
- Sw switch (for branch resistance measurement)

NOTE For IPC  $l_a, l_b$  may be increased if necessary.

**Figure 2 – Typical test circuit for branch connectors**

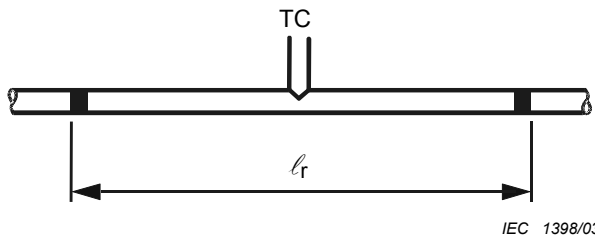

Formulas:

$$R_r = \frac{U_r}{I_r} \times \frac{1}{1 + \alpha(\theta_r - 20)}$$

IEC 1398/03

Figure 3a – Reference conductor

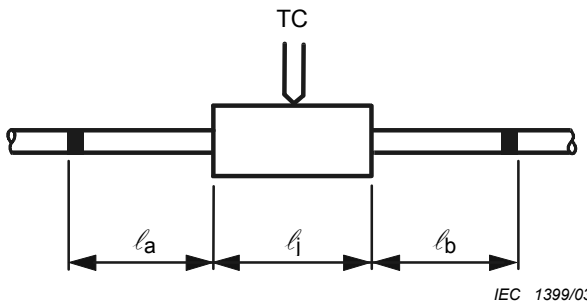

Formulas:

$$R_j = R - R_r \times \frac{(l_a + l_b)}{l_r}$$

$$k = \frac{R_j}{R_r} \times \frac{l_r}{l_j}$$

IEC 1399/03

Reference: main conductor

Figure 3b – Through connector

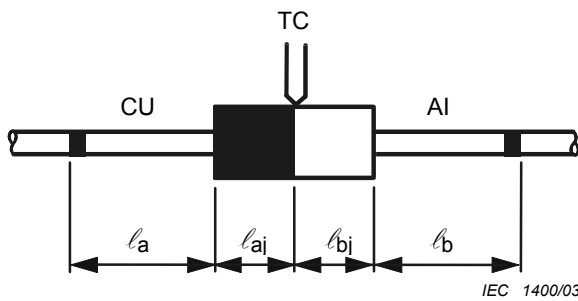

Formulas:

$$R_j = R - \left[ \frac{R_r \text{Cu}}{l_r \text{Cu}} \times l_a + \frac{R_r \text{Al}}{l_r \text{Al}} \times l_b \right]$$

$$k = \frac{R_j}{\frac{R_r \text{Cu}}{l_r \text{Cu}} \times l_{aj} + \frac{R_r \text{Al}}{l_r \text{Al}} \times l_{bj}}$$

IEC 1400/03

Reference: copper and aluminium conductor

Figure 3c – Bimetallic through connector

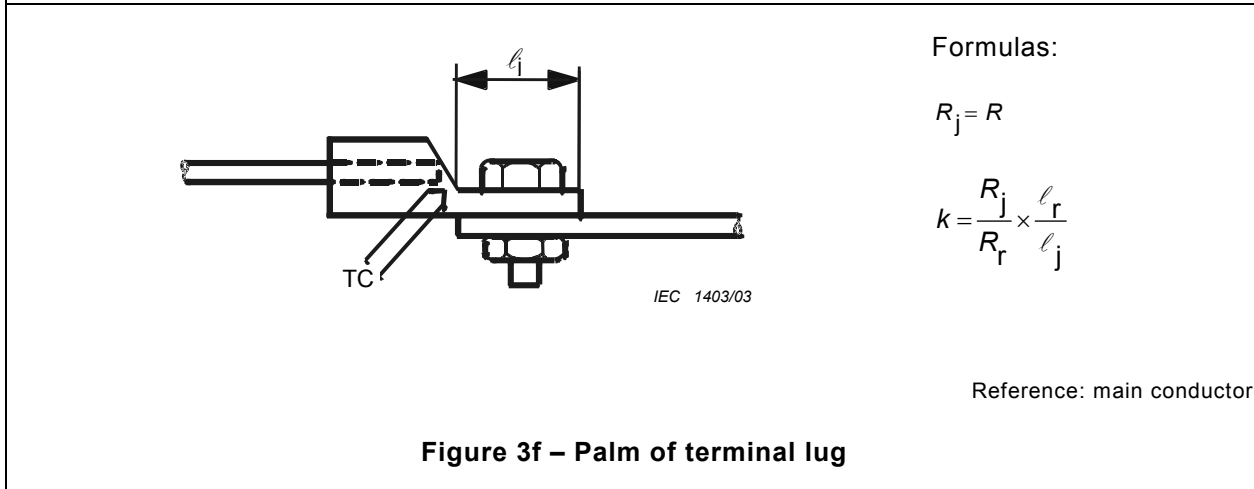
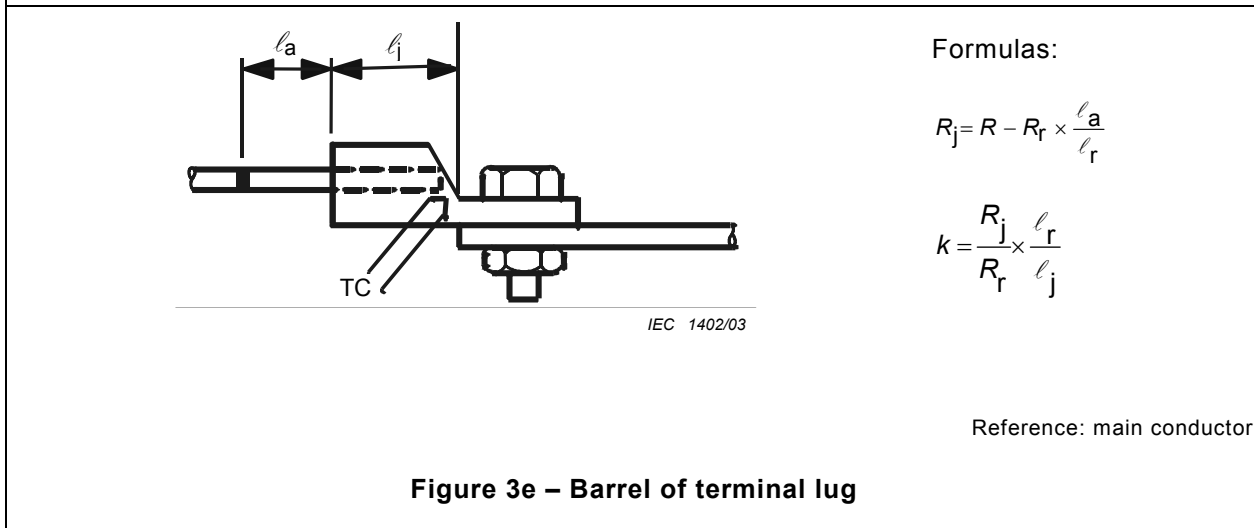
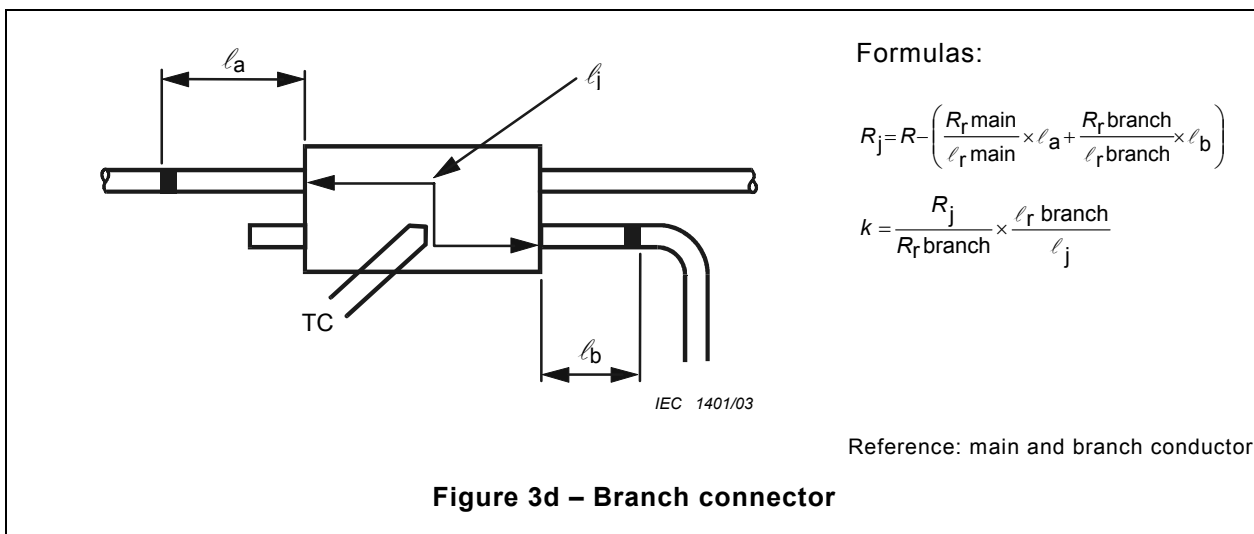



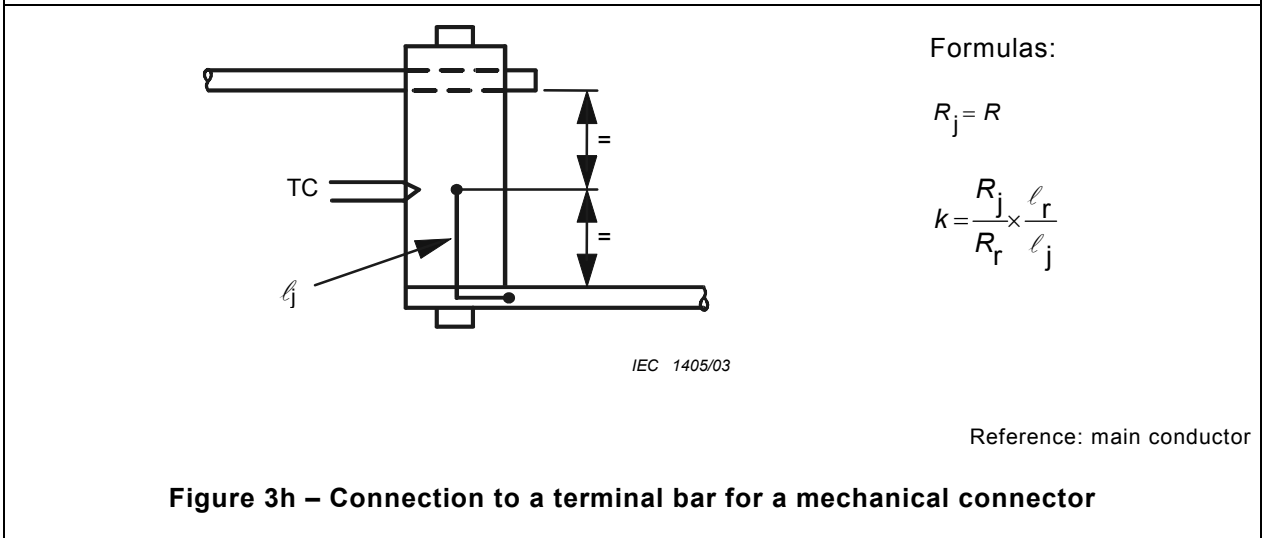
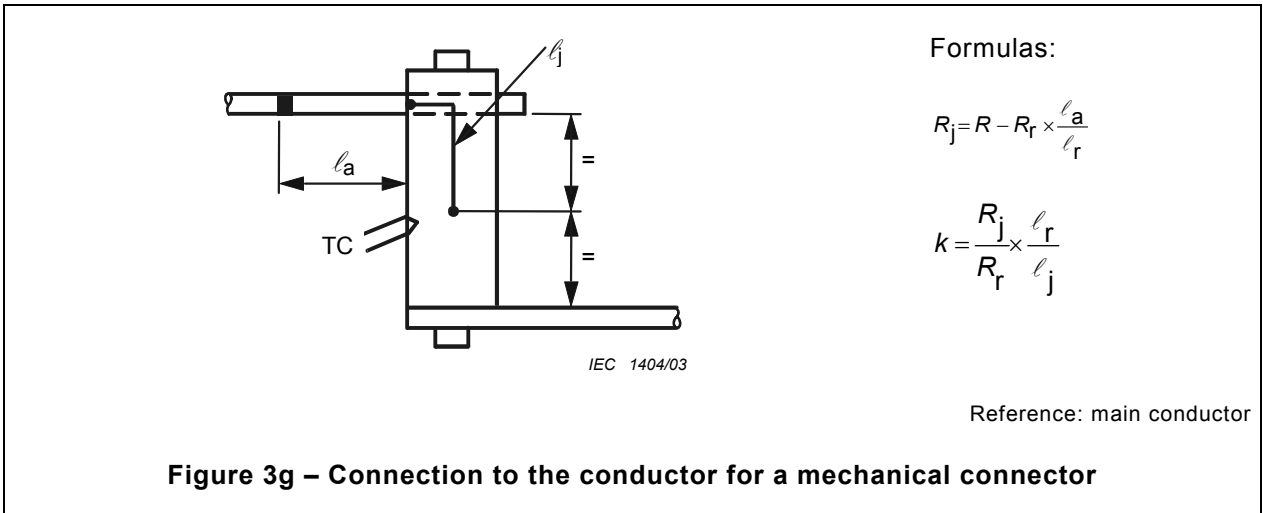

TC = Temperature measurement points

**Figure 3 – Typical cases of resistance measurements**

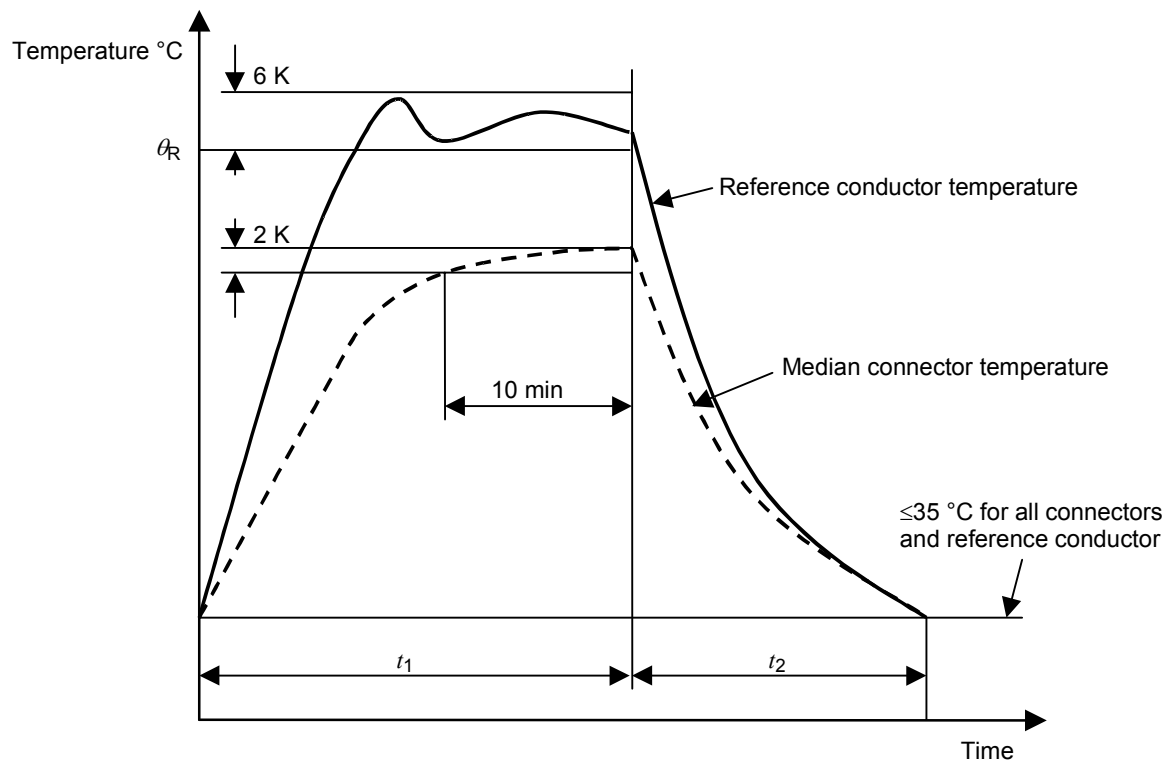

IEC 1406/03

Figure 4 – Second heat cycle

## Annex A (normative)

### Equalizers and their preparation

For stranded conductors, the potential between the strands at measuring points may cause errors in measuring electrical resistance.

Welded or soldered equalizers may be used to overcome this problem and to ensure uniform current distribution in the reference conductor. Welded or soldered equalizers are the recommended methods to ensure reliable measurements.

Other methods may be used provided they give comparable results and do not affect the temperature of the connectors or the reference conductor.

#### A.1 Copper conductors

Special equipment required for copper conductors includes:

- silver solder;
- support;
- cooling plates;
- heating equipment.

Cut the conductors square and clean the ends. Place the ends in contact in a support. Solder the ends with a silver solder, ensuring that the conductor remote from the ends is kept sufficiently cool so as not to be affected.

#### A.2 Stranded aluminium conductors (Figure A.1)

Special equipment required for stranded aluminium conductors includes:

- apparatus for TIG (tungsten inert gas) or MIG (metal inert gas) welding;
- welding support;
- welding rod A5 (1 100), welding rod A5 (1 050) or equivalent.

Cut the conductors square, clean the ends, and melt them with the welding torch. (For cable cross-sectional areas greater than 95 mm<sup>2</sup>, melt the periphery first and then add weld metal to the centre to complete the chamfer.) The length of the chamfer,  $a$ , and the separation between the conductors for final welding  $b$  are as follows:

**Table A.1 – Equalizer dimensions**

Cross-sectional area $A$ mm <sup>2</sup>	$A \leq 95$	$95 < A \leq 240$	$A > 240$
$a$ (mm)	3 to 5	5 to 10	7 to 12
$b$ (mm)	1 to 2	2 to 5	4 to 6

With the conductors supported and spaced by dimensions  $b$ , build weld metal up at the centre and turn the conductors so as to obtain a uniform circular weld profile. Ensure that the conductor remote from the ends is kept sufficiently cool in order not to change the mechanical properties of the conductor in the region where the contact will be made.

### A.3 Dimensions

The dimensions of the equalizer shall be as indicated in Figure A.1.

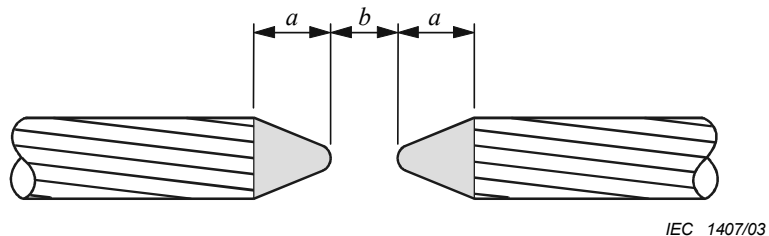

Figure A.1a – Ends prepared

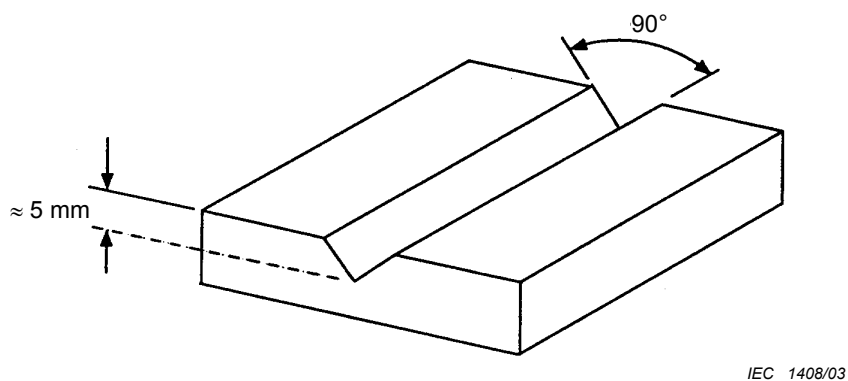
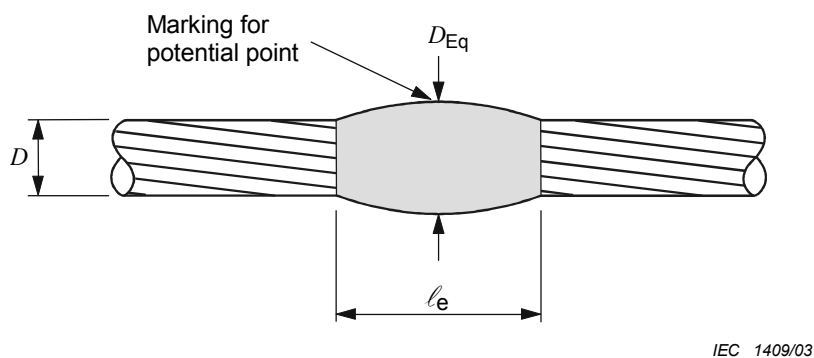

Figure A.1b – Welding/soldering support



where

$$D \leq D_{Eq} \leq 1,2 D$$

$$l_e = 10 \text{ mm to } 15 \text{ mm for cross-sectional area } A \leq 95 \text{ mm}^2;$$

$$l_e = 15 \text{ mm to } 25 \text{ mm for cross-sectional area } 95 \text{ mm}^2 < A \leq 240 \text{ mm}^2;$$

$$l_e = 25 \text{ mm to } 35 \text{ mm for cross-sectional area } A > 240 \text{ mm}^2.$$

Figure A.1c – Welded/soldered equalizer

Figure A.1 – Preparation of equalizers

## Annex B (normative)

### Measurements

#### B.1 Potential points for typical connectors

Potential points for the purpose of resistance measurement are shown in Figures 3a, 3b, 3c, 3d, 3e and 3g. Potential points on solid conductors shall be adjacent to, but not touching, the connector. For stranded conductors, the potential points are the mid-point of the equalizers, which shall be  $15\sqrt{A}$  mm or 150 mm, whichever is the larger, away from the connector. The actual lengths of  $l_a$  and  $l_b$  can vary in a real test set-up at each connector. It is therefore necessary to take these individual readings for the calculation of the resistance for every individual connector. Although it is not a requirement of this standard that resistance measurements be made of the bolted connection to terminal equipment, it is possible to include this in the assessment by making such measurements either directly or by the addition of extra potential points (Figures 3f, 3g and 3h).

#### B.2 Temperature measurement

A good thermal contact between the thermocouple junction and the measuring object shall be established.

In the case of the reference conductor (Figure 3a), the thermocouple shall be positioned at the mid-point and securely located either in a small hole drilled in a solid conductor, or by sliding it under the strands of the outer layer of a stranded conductor.

In the case of connectors (Figures 3b to 3h), the thermocouple may either be inserted in a small hole drilled into the main body of the connector, or be secured to the outside surface. In the latter case, the thermocouple shall be protected from the effect of draughts by a small covering which does not significantly alter the thermal dissipation of the connector.

#### B.3 Equivalent conductor resistance

It is necessary to measure the resistance of a known length of the reference conductor and its temperature (Figure 3a), so that the actual connector resistance  $R_j$  may be calculated, by subtracting the resistance due to the conductor lengths  $l_a$  and  $l_b$ . The various lengths, which need to be recorded, are shown in Figure 3.

It should be noted that in the case of branch connectors, resistances of both the main and the branch reference conductors are used when calculating the actual connector resistance (see Figure 3d).

It is necessary to measure the resistance of the reference conductor on each occasion that the connector resistance measurement is made. All measured resistance values of the reference conductor (corrected by temperature) shall be stable throughout the complete test to show that the equalizers are stable in principle. For the determination of the parameter  $k$  (see Annex E) it is essential that during resistance measurement the reference conductor and all connectors are at ambient temperature.

## Annex C (informative)

### Recommendations to improve accuracy of measurement

#### C.1 Handling the test loop

Bending or vibrations during transport and handling may give rise to mechanical forces, which affect the contact resistance of the test objects and should be avoided.

The same measuring points should be used throughout the test, since calculation always refers to the initial situation. Verification of measuring points, especially after the short-circuit test, is advised.

#### C.2 Measurements, instruments and readings

For stranded conductors, the distances between any equalizer in the test set-up where no connectors are installed may be used for verification of resistance measurements.

All recorded values should show that the equalizers have acceptable stability throughout the test.

Check the validity of calibration or make a calibration of each instrument prior to the test. If possible, calibrate the whole measuring chain.

Temperature readings may easily be checked at a temperature of 100 °C in boiling water and at 0 °C in ice water.

For measuring the current, a calibrated shunt may be introduced into the test loop.

If possible, use the same instrument for voltage ( $\Delta U_{DC}$ ), current ( $\Delta U_{DC}$  of a shunt) and temperature ( $\Delta U_{DC}$  of thermocouple-voltage output) measurement.

A calibrated resistance with a value in the same order as the readings may be used for the calibration of the voltage measurement or a direct measurement of the resistance. A check should be made before during and after the test.

It is recommended:

- to use the same instruments throughout the whole test;
- to avoid, whenever possible, the replacement of any instrument, since the change in the systematic uncertainty may influence the assessment of the measuring results;
- to use automatic storage of the measured values to avoid copy errors;
- to use a validated computer program for the calculation to avoid errors by accident.

When calculating the  $k$  value, it is possible to use the measured resistance values of the reference conductor and the connectors without any temperature correction, provided that the resistance of the reference conductor does not change during the test and the temperatures of all parts of the test loop are the same and in stable conditions when resistance measurements are made.

Every effort should be made to avoid spurious readings.

Data of instrument performance should be given in the test report.

## Annex D (informative)

### Determination of the value of the short-circuit current

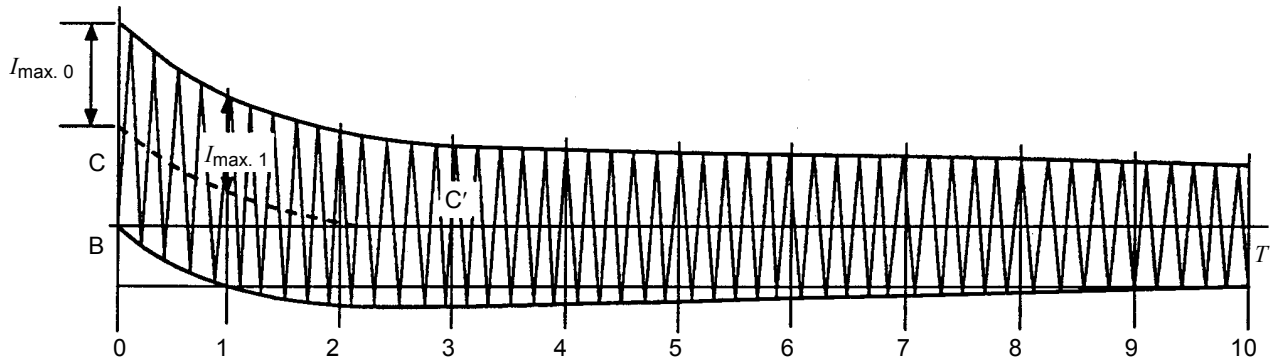

IEC 1410/03

On the diagram giving the current as a function of time, the total time BT is divided into 10 equal parts and the value of the alternating current component is measured at the verticals at points 0, 1, 2, . . . . ., 10.

These values are designated by  $I_{\max 0}$ ,  $I_{\max 1}$ ,  $I_{\max 2}$ , . . . . .  $I_{\max 10}$ .

The effective values are then  $I_i = I_{\max i} / \sqrt{2}$

and  $I_{\max}$  is the maximum value of the alternating component of the current at each point.

The equivalent r.m.s. current during this time BT is given by:

$$I_{\text{rms}} = \sqrt{\frac{1}{30} \left[ I_0^2 + 4(I_1^2 + I_3^2 + I_5^2 + I_7^2 + I_9^2) + 2(I_2^2 + I_4^2 + I_6^2 + I_8^2) + I_{10}^2 \right]}$$

NOTE 1 The direct current component (CC') is neglected.

NOTE 2 This annex is consistent with Annex B of IEC 60694.

## Annex E (normative)

### Calculation method

This statistical evaluation follows IEC 60493-1.

#### E.1 Measurements made

To the cycles listed in 6.3.3, the following measurements with the test loop at ambient temperature shall be taken (see 6.2 and Annex B):

- $U$  potential difference between measurement points spanning each connector;
- $I$  direct current at the moment of measuring  $U$ ;
- $\theta$  temperature of each connector at the moment of measuring  $U$ ;
- $U_r$  potential difference between measurement points on the reference conductor;
- $I_r$  direct current at the moment of measuring  $U_r$ ;
- $\theta_r$  temperature of the reference conductor at the moment of measuring  $U_r$ .

The above is the recommended method. Direct measurements of resistance may, alternatively, be used for any of the above  $U/I$  values.

In addition, temperature measurements will have been recorded on each connector and on the reference conductor on the cycle prior to, or following the resistance measurements.

Distances  $l_a$ ,  $l_b$ ,  $l_j$ ,  $l_r$  defined in Figure 3, are measured and are applicable for the whole test. The distances shall be measured with a tolerance of  $\pm 2$  mm for lengths  $\geq 40$  mm, or  $\pm 5$  % for lengths  $< 40$  mm.

#### E.2 Connector resistance factor $k$

The resistance, referred to 20 °C, between measuring points spanning a connector is as follows:

$$R = \frac{U}{I} \times \frac{1}{1 + \alpha(\theta - 20)}$$

where the temperature coefficient of resistance  $\alpha$ , for the purposes of this standard, is regarded as equal for copper and aluminium:

$$\alpha = 0,004 \text{ K}^{-1}$$

The resistance of the reference conductor, referred to 20 °C, is as follows:

$$R_r = \frac{U_r}{I_r} \times \frac{1}{1 + \alpha(\theta_r - 20)}$$



The connector resistance  $R_j$  is then:

$$R_j = R - R_r \times \frac{(\ell_a + \ell_b)}{\ell_r}$$

and the connector resistance factor  $k$ :

$$k = \frac{R_j}{R_r} \times \frac{\ell_r}{\ell_j} \quad (\text{E.1})$$

### E.3 Initial scatter $\delta$

The scatter between the six values of  $k$  (one value for each connector) at cycle zero is calculated as follows:

calculate the mean value:

$$\bar{K}_0 = \frac{1}{6} \sum_1^6 k$$

then the standard deviation:

$$s_0 = \sqrt{\frac{1}{5} \sum_1^6 (k - \bar{K}_0)^2}$$

and finally the scatter:

$$\delta = \frac{1}{\sqrt{6}} \frac{s_0}{\bar{K}_0} t_s$$

where

$t_s$  is the Student coefficient;

$t_s = t_{5;0,995} = 4,032$  for 99 % two-sided confidence level and five degrees of freedom;

hence:

$$\delta = 1,65 \frac{s_0}{K_0} \quad (\text{E.2})$$

### E.4 Mean scatter $\beta$

This scatter shall be determined using the last 11 measurement readings of resistance. These 11 readings start at the 250<sup>th</sup> cycle point, and then every 75 cycles up to 1000 cycles. A tolerance of  $\pm 10$  cycles is permitted on the timing of any reading, and in this case, the statistical formulae listed in this standard are applicable. Outside this tolerance, a detailed statistical treatment is necessary. For convenience of calculation, the origin is transferred to the mid-point of the 11 readings and the statistical variable  $x$  is introduced (see Figure E.1). The symbol  $x$  has the values 0,  $\pm 1$ ,  $\pm 2$ , . . . . . ,  $\pm 5$ .

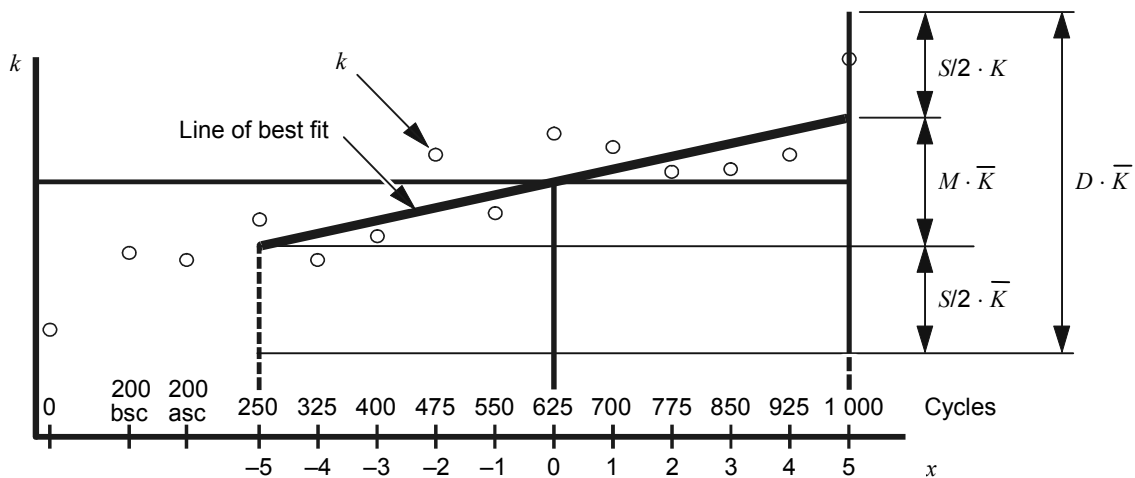

IEC 1411/03

bsc = before short-circuit

asc = after short-circuit

**Figure E.1 – Graphic example of assessment of an individual connector for Class A**

For each connector, its mean value over the interval  $x = -5$  to  $+5$  shall be calculated.

$$\bar{k} = \frac{1}{11} \sum_{-5}^{+5} k \quad (\text{E.3})$$

Hence six values are obtained. The mean of these six values is then:

$$\bar{K} = \frac{1}{6} \sum_1^6 \bar{k}$$

The standard deviation:

$$s = \sqrt{\frac{1}{5} \sum_1^6 (\bar{k} - \bar{K})^2}$$

and the scatter:

$$\beta = \frac{1}{\sqrt{6}} \frac{s}{K} t_s$$

where  $t_s = 4,032$  as before.

Hence:

$$\beta = 1,65 \frac{s}{K} \quad (\text{E.4})$$

## E.5 Change in resistance factor of each connector

To calculate the possible variation in the resistance factor of a connector over the last 11 measurement readings, the method of least squares shall be used to determine the line of best fit. To the change in resistance factor of this line is added a quantity, the magnitude of which depends upon the confidence interval of scatter of resistance factor values about the line of best fit.

### E.5.1 Line of best fit

The slope of the line of best fit over the range  $x = -5$  to  $+5$  is given by:

$$b = \frac{\sum_{-5}^{+5} x k}{\sum_{-5}^{+5} x^2}$$

Hence, the per-unit change in resistance factor is:

$$M = 10 \frac{b}{\bar{k}} \quad (\text{E.5})$$

where  $\bar{k}$  has the value given by equation (E.3).

The parameter  $M$  is evaluated for each of the six connectors.

### E.5.2 Confidence interval $\delta_i$

The confidence interval  $\delta_i$  for the change in resistance factor is:

$$\delta_i = t_s \sigma$$

where

$t_s$  is the Student coefficient;

$t_s = t_{9;0,95} = 1,833$  for a 90 % two-sided confidence level and  $(11 - 2) = 9$  degrees of freedom;

$\sigma$  is the standard error estimated from the line of best fit at  $x = +5$  or  $x = -5$ .

It can be shown that  $\sigma$ , for 11 measurements, is:

$$\sigma = 0,564 \times \sqrt{\frac{\sum_{-5}^{+5} (k - \bar{k} - b \cdot x)^2}{9}}$$

$$\sigma = 0,564 \times s_j$$

The expression under root sign is the standard deviation of the connector from the line of best fit. We define this value  $s_j$  since it relates to an individual connector and it should not therefore be confused with the standard deviation of the six connectors,  $s$ , calculated at the mean measurement position  $x = 0$  and used for determining the scatter  $\beta$ .

It should be noted that the above expression for  $s_j$  can also be determined by simplifying to:

$$s_j = \frac{1}{3} \sqrt{|11[(\bar{k}^2) - (\bar{k})^2] - 110 b^2|}$$

where  $\bar{k}$  has the value given in Equation (E.3)

and

$$(\bar{k}^2) = \frac{1}{11} \sum_{-5}^{+5} k^2$$

The total per-unit deviation from the line of best fit is then:

$$S = \frac{2 \cdot t_s \cdot \sigma}{\bar{k}} = \frac{2 \cdot 1,833 \cdot 0,564 \cdot s_j}{\bar{k}} = \frac{2,07 \cdot s_j}{\bar{k}}$$

The parameter  $S$  is evaluated for each of the six connectors.

### E.5.3 Change in resistance factor $D$

From E.5.1 and E.5.2, the estimated change in the value of  $k$  for each connector over the last 11 measurements is

$$D = |M| + S = \frac{|10b|}{\bar{k}} + \frac{2,07 s_j}{\bar{k}} \quad (\text{E.6})$$

### E.6 Resistance factor ratio $\lambda$

$$\lambda = \frac{k}{k_0}$$

where

$k$  is the connector resistance factor for each connector found at any stage of the measurement series;

$k_0$  is the connector resistance factor of the same connector measured at cycle zero.

### E.7 Maximum temperatures $\theta_{\max}$

For each connector, the value of  $\theta_{\max}$  shall be recorded. This is the maximum value of the connector temperature reached during any stage of the test. Simultaneously, the value of  $\theta_{\text{ref}}$  shall also be recorded.

## Annex F (informative)

### Explanation of the calculation method

Symbols used in this annex are given in the following tables:

**Table F.1 – Indices**

Symbols		Indices
Annex E	Annex F	
-	$i$	Connector number from 1 to 6
-	$j$	Measurement number from 1 to 14
$x$	$x$	Statistical variable for the transformation of the coordination system for the last 11 measurements starting from $j = 4$ equal to $x = -5$ to $j = 14$ equal to $x = +5$ in the case of connectors according to Class A

**Table F.2 – Measured variables**

Symbols		Measured variables
Clause 4	Annex F parameter	
$I$	$I^{ij}$	Direct current (in A) flowing through connector $i$ during the measurement $j$
$I_r$	$I_r^j$	Corresponding direct current (in A) flowing through the reference conductor during the measurement $j$
$U$	$U^{ij}$	Potential difference (in V) between the two measuring points of connector $i$ during the measurement $j$
$U_r$	$U_r^j$	Corresponding potential difference (in V) between the two measuring points of the reference conductor
$\theta$	$\theta^{ij}$	Temperature (in °C) of connector $i$ during the measurement $j$
-	$\theta_r^j$	Corresponding temperature (in °C) of the reference conductor during the measurement $j$

Values regarded as constant during the electrical testing procedure are given in Table F.3.

**Table F.3 – Constants**

Symbols		Constants
Clause 4	Annex F constants	
$l_a$	$l_a^i$	Measured length spanning from connector $i$ to its first measuring point (in mm)
$l_b$	$l_b^i$	Length spanning from connector $i$ to its second measuring point (in mm)
$l_j$	$l_{con}$	Virtual length of all connectors defined in accordance with Figure 3 (in mm). The index has been changed to avoid confusion with the measurement number
$l_r$	$l_r$	Measured length (in mm) of the reference conductor
$\alpha$	$\alpha$	Temperature coefficient (in K <sup>-1</sup> ), depending on the material of the conductor

Using these measured variables and constants, the following quantities, shown in Table F.4, can be calculated.

**Table F.4 – Calculated variables**

Symbols		Calculated variables
Clause 4	Annex F variables	
$R_j$	$R_{con}^{ij}$	Pure resistance of connector $i$ during measurement $j$ , adjusted to 20 °C
$R$	$R_{ij}$	Resistance between measuring points of connector $i$ during measurement $j$ , adjusted to 20 °C
$R_r$	$R_r^i$	Resistance of the reference conductor during measurement $j$ , adjusted to 20 °C
$k$	$k^{ij}$	Resistance factor of connector $i$ during measurement $j$
$\bar{K}_0$	$\bar{k}_1$	Mean of the resistance factors of the six connectors immediately after installation, before heat cycle 1, representing an estimator for the unknown true value
$s_0$	$s_{.1}$	Standard deviation of the resistance factors of the six connectors before heat cycle 1, representing an estimator for the unknown statistical standard deviation $\sigma_k$
$\delta$	$\delta$	“Relative initial scatter” of the mean of the resistance factors of the six connectors, before heat cycle 1
$\bar{k}$	$\bar{k}_i$	Mean of the resistance factors of connector $i$ , calculated over the last 11 measurements
$\bar{K}$	$\bar{k}$	Overall mean of all resistance factors, calculated over the last 11 measurements
$s$	$s$	Standard deviation of the means of the resistance factors of the six connectors (calculated over the last 11 measurements) from the overall mean
$\beta$	$\beta$	Relative mean scatter of the resistance factors of the six connectors (calculated over the last 11 measurements) from the overall mean
$b$	$\hat{b}_i$	Estimated slope of the regression line, calculated from a simple linear regression on the resistance factors of connector $i$ over the last 11 measurements
$M$	$M^i$	Estimated relative change of the resistance factors of connector $i$ over the last 11 measurements
$s_j$	$s^i$	Standard deviation of the residuals from the regression line, for connector $i$
-	$s_{\hat{b}_i}$	Standard deviation of the estimated slope of the regression line for connector $i$
$\sigma$	$\sigma^i$	Maximum one-sided deviation from the regression line for connector $i$
$\delta_i$	$\delta^i$	Maximum one-sided scatter from the regression line for connector $i$
$S$	$S^i$	Relative maximum overall scatter from the regression line for connector $i$
$D$	$D^i$	Relative statistical overall change of connector $i$ over the last 11 measurements
$\lambda$	$\lambda^{ij}$	Resistance factor ratio of connector $i$ during measurement $j$ related to the initial resistance factor of this connector

The following quantities are calculated and used to decide whether a type of connector will satisfy the requirements of this standard. The aim is to define criteria for the resistance stability of a tested connector type during the heat cycle period of the test. The graphs in the examples are made using simulated data showing extreme behaviour to demonstrate the effects on the statistical method.

## F.1 Measurements made

At certain  $j$  intervals throughout the heat cycle tests, the resistance factor of each connector should be calculated. For each resistance factor, a series of measurements at ambient temperature should be recorded, see Table F.5.

**Table F.5 – Repeatedly measured parameters**

Location	Connector 1	Connector 2	Connector 3	Connector 4	Connector 5	Connector 6	Reference conductor
Measurement $j$	$U^{1j}, I^{1j}, \theta^{1j}$	$U^{2j}, I^{2j}, \theta^{2j}$	$U^{3j}, I^{3j}, \theta^{3j}$	$U^{4j}, I^{4j}, \theta^{4j}$	$U^{5j}, I^{5j}, \theta^{5j}$	$U^{6j}, I^{6j}, \theta^{6j}$	$U_r^j, I_r^j, \theta_r^j$

Each resistance measurement normally consists of an individual measurement of the value for the voltage drop between the measuring points caused by the related DC-current-value measured at a certain temperature. The temperature on all measured elements should be at the same level at ambient temperature. When measuring the voltage drop at all measuring points automatically, almost at the same time, the current can be regarded as constant.

The measuring points should be marked clearly and should not be changed during the test. Then the distances can be regarded as constant as long as there was no modification of the test set-up. Depending on actual installation conditions, the lengths  $\ell_a$  and  $\ell_b$  can be slightly different. Therefore it is necessary to use individual lengths for all connectors.  $\ell_{con}$  depends on the design of the connector. The length after installation should be used according to Figure 3.

## F.2 Connector resistance factor $k$

The connector resistance factor  $k^{ij}$  is a multiple standardized parameter to acquire a universal description for all kind of connectors. The first standardization is made by relating the connector resistance to its length. The second standardization is made by relating this length adjusted resistance of the connector to the length adjusted resistance of the used conductor. The third standardization is necessary for the temperature, because the measured resistance is a function of the temperature characteristic of the used material, and temperature can vary between 15 °C and 30 °C during the long period of testing.

The calculation of the resistance factor  $k^{ij}$  is made by dividing resistance  $R_{con}^{ij}$ , adjusted to its length  $\ell_{con}$ , by resistance  $R_r^j$  adjusted to its length  $\ell_r$ .

$$k^{ij} = \frac{\frac{R_{con}^{ij}}{\ell_{con}}}{\frac{R_r^j}{\ell_r}}$$

$R_r^j$  represents the resistance (referred to 20 °C) spanning the reference conductor during the heat cycle  $j$ .

$$R_r^j = \frac{U_r^j}{I_r^j} \frac{1}{1 + \alpha(\theta_r^j - 20)}$$

$R_{\text{con}}^{ij}$  represents the pure connector resistance (referred to 20 °C) of connector  $i$  during the heat cycle  $j$ . This is the resistance  $R^{ij}$  between the measuring points subtracted by the involved conductor resistance, which is set equal to the reference conductor resistance of the same length.

$$R_{\text{con}}^{ij} = R^{ij} - R_r^j \cdot \frac{\ell_a^i + \ell_b^i}{\ell_r} \quad \text{with} \quad R^{ij} = \frac{U^{ij}}{I^{ij}} \frac{1}{1 + \alpha(\theta^{ij} - 20)}$$

Thus 72 resistance factors for connectors of Class B and 84 resistance factors for connectors of Class A (see Table F.6) should be calculated from the recorded data for the assessment of results.

**Table F.6 – Number of calculated connector resistance factors  $k^{ij}$  for Class A connectors**

Measurement $j$ of Class A	Connector 1	Connector 2	Connector 3	Connector 4	Connector 5	Connector 6
1	$k^{1,1}$	$k^{2,1}$	$k^{3,1}$	$k^{4,1}$	$k^{5,1}$	$k^{6,1}$
2	$k^{1,2}$	$k^{2,2}$	$k^{3,2}$	$k^{4,2}$	$k^{5,2}$	$k^{6,2}$
3	$k^{1,3}$	$k^{2,3}$	$k^{3,3}$	$k^{4,3}$	$k^{5,3}$	$k^{6,3}$
4	$k^{1,4}$	$k^{2,4}$	$k^{3,4}$	$k^{4,4}$	$k^{5,4}$	$k^{6,4}$
5	$k^{1,5}$	$k^{2,5}$	$k^{3,5}$	$k^{4,5}$	$k^{5,5}$	$k^{6,5}$
6	$k^{1,6}$	$k^{2,6}$	$k^{3,6}$	$k^{4,6}$	$k^{5,6}$	$k^{6,6}$
7	$k^{1,7}$	$k^{2,7}$	$k^{3,7}$	$k^{4,7}$	$k^{5,7}$	$k^{6,7}$
8	$k^{1,8}$	$k^{2,8}$	$k^{3,8}$	$k^{4,8}$	$k^{5,8}$	$k^{6,8}$
9	$k^{1,9}$	$k^{2,9}$	$k^{3,9}$	$k^{4,9}$	$k^{5,9}$	$k^{6,9}$
10	$k^{1,10}$	$k^{2,10}$	$k^{3,10}$	$k^{4,10}$	$k^{5,10}$	$k^{6,10}$
11	$k^{1,11}$	$k^{2,11}$	$k^{3,11}$	$k^{4,11}$	$k^{5,11}$	$k^{6,11}$
12	$k^{1,12}$	$k^{2,12}$	$k^{3,12}$	$k^{4,12}$	$k^{5,12}$	$k^{6,12}$
13	$k^{1,13}$	$k^{2,13}$	$k^{3,13}$	$k^{4,13}$	$k^{5,13}$	$k^{6,13}$
14	$k^{1,14}$	$k^{2,14}$	$k^{3,14}$	$k^{4,14}$	$k^{5,14}$	$k^{6,14}$

### F.3 Initial scatter $\delta$

The initial scatter gives information as to how the design of a contact system will behave on a certain conductor immediately after installation before any ageing effect starts. The six tested samples are considered to be enough to estimate the identification of a connector “family”. If the resistance factors for the tested connector type are almost equal, it may be assumed that one will get the same result when using the described design and assembling method on the same related type of conductor. For this calculation the  $k$  factors of the first measurement campaign (Table F.6, row 1,  $j = 1$ ) are used. The assumption is made that the resistance factors follow a normal distribution with an unknown true value and an unknown variance  $\sigma_k^2$  :

- $\bar{k}_1$  Empirical mean of the resistance factors of the six connectors before heat cycle 1

$$\bar{k}_1 = \frac{1}{6} \sum_{i=1}^6 k^{i1} = \frac{1}{6} (k^{1,1} + k^{2,1} + k^{3,1} + k^{4,1} + k^{5,1} + k^{6,1})$$



This parameter is an estimator for the unknown statistical mean of that resistance factor which represents the connector type before heat cycle 1.

- $s_1$  Empirical standard deviation of the resistance factors of the six connectors before heat cycle 1:

$$s_1 = \sqrt{\frac{1}{5} \sum_{i=1}^6 (k^{i1} - \bar{k}_{.1})^2}$$

This parameter estimates the unknown statistical standard deviation  $\sigma_k$  from the mean of the six connectors before heat cycle 1.

- $\delta$  Relative initial scatter of the mean of the resistance factors of the six connectors, before heat cycle 1 standardized by the mean:

$$\delta = \frac{\frac{1}{\sqrt{6}} \times s_1 \times t_{5,0,995}}{\bar{k}_{.1}} = \frac{1,65 \times s_1}{\bar{k}_{.1}}$$

The standardization, often used in this assessment, allows direct comparability with other connector types. This parameter is a dimensionless quantity, which stands for a percentage of deviation from the estimated mean resistance factor and indicates that, for a given probability, a resistance factor is not expected to exceed. It is based on a 99 % confidence interval for the unknown true mean before heat cycle 1. The  $t_{5,0,995}$  quantile here indicates

that the 99 % confidence interval  $\bar{k}_{.1} \pm t_{5,0,995} \cdot \frac{s_1}{\sqrt{6}}$  will cover the unknown true mean of the

resistance factors with a probability of 99 % before heat cycle 1. It is not possible though to conclude that each resistance factor will be covered by this confidence interval with a probability of 99 %.

A necessary and realistic assumption for this quantity is that the resistance factors of the six connectors independently and identically follow a normal distribution with unknown mean and unknown standard deviation.

Figure F.1 gives an example for initial connector resistance factors and the calculated relative initial scatter. The resistance factors  $k^{1,1}$  to  $k^{6,1}$  of connectors 1 to 6 (labelled here as C1 to C6) are plotted as circles and the estimated mean resistance factor  $\bar{k}_{.1}$  is represented by a cross. The vertical dotted lines show the upper and lower bounds for a 99 % confidence interval (C.I.) for the unknown true mean and the horizontal discontinued line represents the initial scatter  $\delta \cdot \bar{k}_{.1}$ . Since the initial resistance factors are assumed to follow a normal distribution, the density of this distribution is also given in Figure F.1.

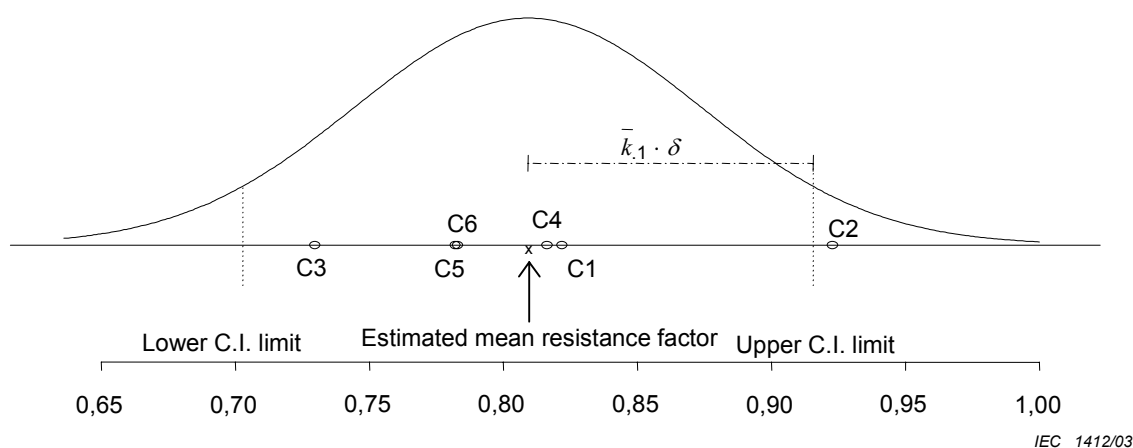

**Figure F.1 – Plot of connector resistance factors and parameter  $\delta$  before heat cycle 1**

#### F.4 Mean scatter $\beta$

The mean scatter  $\beta$  shows if all connectors react with the same behaviour of their resistance factors to the heat cycling test and therefore can be identified as representative of the same tested design. This scatter is determined using the last 11 connector resistance factors calculated from the measurement readings. These 11 readings start at the 250<sup>th</sup> cycle point, and then every 75 cycles up to 1000 cycles. For convenience of calculation, the origin is transferred to the mid-point of the 11 readings and the statistical dummy variable 'x' is introduced, see Table F.7.

**Table F.7 – Connector resistance factors  $k^{ij}$  for Class A connectors related to the dummy variable  $x$ , the initial scatter  $\delta$  and the mean scatter  $\beta$**

Heat cycle no.	$x$	$i \rightarrow$ $\downarrow j$	Con- nector 1	Con- nector 2	Connector 3	Con- nector 4	Con- nector 5	Con- nector 6	Scatter
0		1	$k^{1,1}$	$k^{2,1}$	$k^{3,1}$	$k^{4,1}$	$k^{5,1}$	$k^{6,1}$	$\delta$
200 (bsc) <sup>a</sup>		2	$k^{1,2}$	$k^{2,2}$	$k^{3,2}$	$k^{4,2}$	$k^{5,2}$	$k^{6,2}$	
200 (asc) <sup>b</sup>		3	$k^{1,3}$	$k^{2,3}$	$k^{3,3}$	$k^{4,3}$	$k^{5,3}$	$k^{6,3}$	
250	+5	4	$k^{1,4}$	$k^{2,4}$	$k^{3,4}$	$k^{4,4}$	$k^{5,4}$	$k^{6,4}$	$\beta$
325	+4	5	$k^{1,5}$	$k^{2,5}$	$k^{3,5}$	$k^{4,5}$	$k^{5,5}$	$k^{6,5}$	
400	+3	6	$k^{1,6}$	$k^{2,6}$	$k^{3,6}$	$k^{4,6}$	$k^{5,6}$	$k^{6,6}$	
475	+2	7	$k^{1,7}$	$k^{2,7}$	$k^{3,7}$	$k^{4,7}$	$k^{5,7}$	$k^{6,7}$	
550	+1	8	$k^{1,8}$	$k^{2,8}$	$k^{3,8}$	$k^{4,8}$	$k^{5,8}$	$k^{6,8}$	
625	0	9	$k^{1,9}$	$k^{2,9}$	$k^{3,9}$	$k^{4,9}$	$k^{5,9}$	$k^{6,9}$	
700	-1	10	$k^{1,10}$	$k^{2,10}$	$k^{3,10}$	$k^{4,10}$	$k^{5,10}$	$k^{6,10}$	
775	-2	11	$k^{1,11}$	$k^{2,11}$	$k^{3,11}$	$k^{4,11}$	$k^{5,11}$	$k^{6,11}$	
850	-3	12	$k^{1,12}$	$k^{2,12}$	$k^{3,12}$	$k^{4,12}$	$k^{5,12}$	$k^{6,12}$	
925	-4	13	$k^{1,13}$	$k^{2,13}$	$k^{3,13}$	$k^{4,13}$	$k^{5,13}$	$k^{6,13}$	
1 000	-5	14	$k^{1,14}$	$k^{2,14}$	$k^{3,14}$	$k^{4,14}$	$k^{5,14}$	$k^{6,14}$	

<sup>a</sup> bsc = before short-circuit test.  
<sup>b</sup> asc = after short-circuit test.

- $\bar{k}_i$  Empirical mean of the resistance factors of connector  $i$ , calculated over the last 11 measurements:

$$\bar{k}_i = \frac{1}{11} \sum_{j=4}^{14} k^{ij}$$

This empirical mean is an estimator for an unknown statistical mean of the resistance factors of one individual connector  $i$ , calculated over the last 11 measurements.

- $\bar{k}$  Empirical overall mean of all resistance factors:

$$\bar{k} = \frac{1}{6} \sum_{i=1}^6 \bar{k}_i = \frac{1}{6} \times \frac{1}{11} \sum_{i=1}^6 \sum_{j=4}^{14} k^{ij} = \frac{1}{6} \times \frac{1}{11} \sum_{i=1}^6 \sum_{x=-5}^{x=+5} k^{ix}$$

This empirical mean estimates the unknown statistical mean of the resistance factors of all connectors, calculated over the last 11 measurements representing the typical behaviour of the tested connector family during heat cycling.

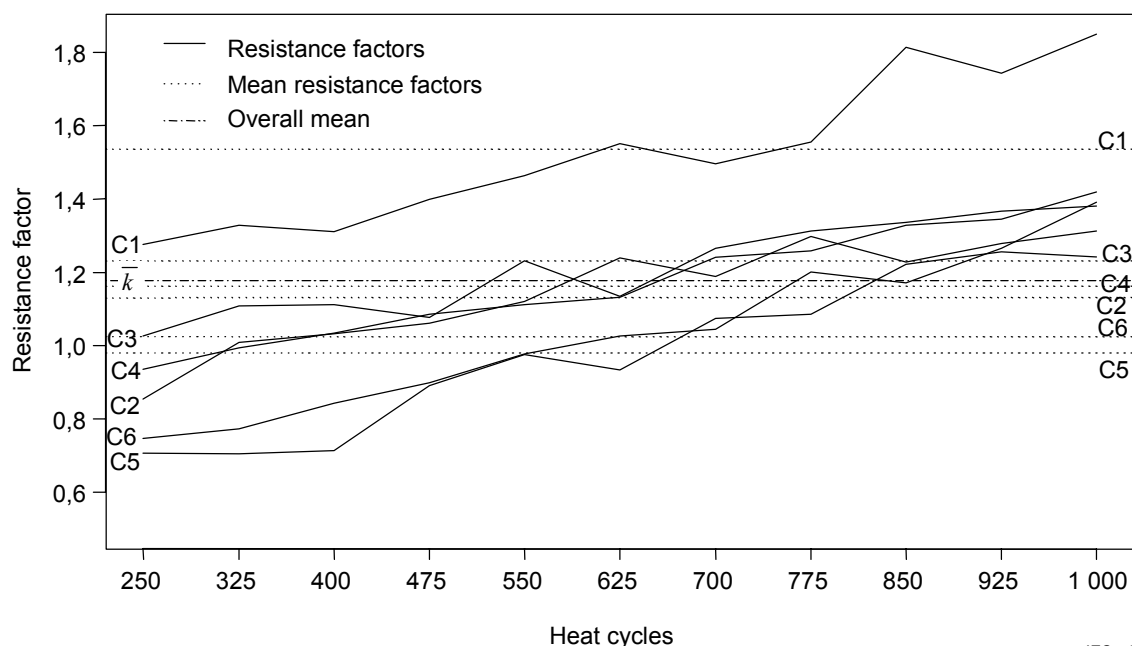

IEC 1413/03

**Figure F.2 – Plot of resistance factors  $k^{ij}$ , estimated mean resistance factors  $\bar{k}_i$  and estimated overall mean  $\bar{k}$**

Figure F.2 gives an example for the progression of the resistance factors  $k^{ij}$  of all six connectors (labelled C1 to C6 and plotted using a solid line) as well as the six corresponding mean resistance factors  $\bar{k}_i$  (dotted lines) and the overall mean  $\bar{k}$  (discontinued line).

- $s$  Empirical standard deviation of the means  $\bar{k}_i$  of the resistance factors of the six connectors (calculated over the last 11 measurements) from the overall mean.

$$s = \sqrt{\frac{1}{5} \sum_{i=1}^6 (\bar{k}_i - \bar{k})^2}$$

This empirical standard deviation is an estimator for the unknown statistical standard deviation of the means  $\bar{k}_i$  from the overall mean.

- $\beta$  Relative mean scatter of the mean resistance factors of the six connectors (calculated over the last 11 measurements) from the overall mean (standardized by the overall mean).

$$\beta = \frac{\frac{1}{\sqrt{6}} \times s \times t_{5;0,995}}{\bar{k}} = \frac{1,65 \times s}{\bar{k}}$$

This parameter is a dimensionless quantity, which stands for a percentage of deviation from the overall mean and indicates that a mean resistance factor  $\bar{k}_i$  is not expected to exceed a certain probability. It is based on a 99 % confidence interval for the unknown true overall resistance factor. The  $t_{5;0,995}$ -quantile here indicates, that the 99 % confidence interval

$\bar{k} \pm t_{5;0,995} \times \frac{s}{\sqrt{6}}$  will cover the unknown true overall resistance factor of connector  $i$  with a

probability of 99 %. It does not imply, however, that all mean resistance factors  $\bar{k}_i$  will be covered by this confidence interval with a probability of 99 %.

For this quantity, the assumption can be made that the empirical means  $\bar{k}_i$  for all connectors  $i$  independently and identically follow a normal distribution.

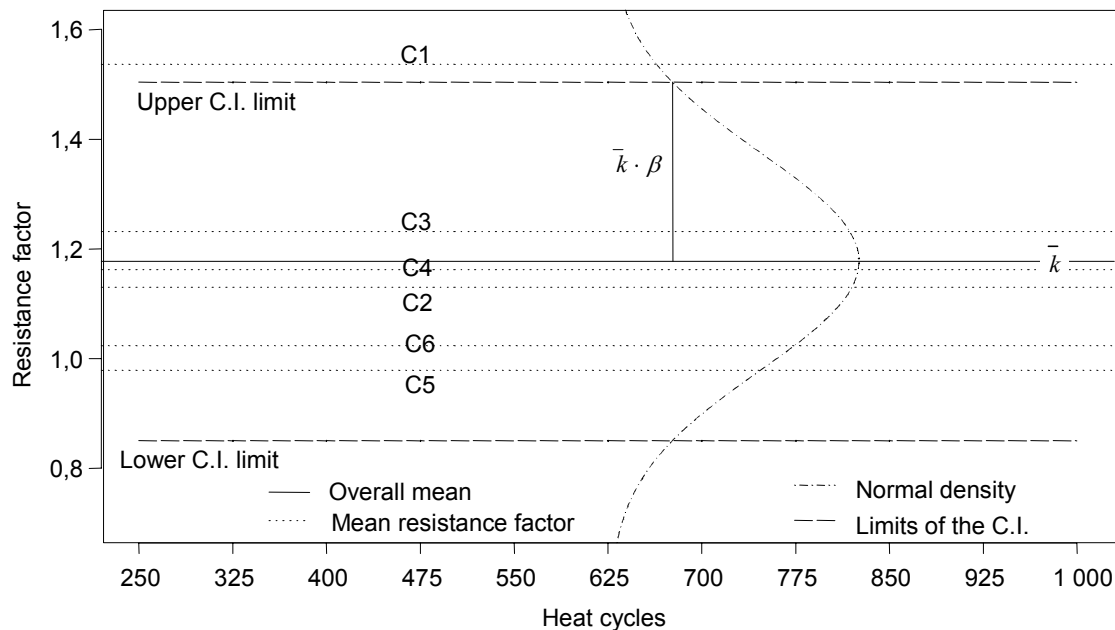

**Figure F.3 – Plot of estimated mean resistance factors  $\bar{k}_i$ , estimated overall mean  $\bar{k}$  and parameter  $\beta$**

Figure F.3 shows the estimated mean resistance factors  $\bar{k}_i$  (plotted using a dotted line) of the six connectors (labelled as C1 to C6) as well as the estimated overall mean  $\bar{k}$  (horizontal solid line) and also the upper and lower 99 % confidence limit for the unknown true overall resistance factor (discontinued lines). The calculated mean scatter  $\beta \times \bar{k}$  is indicated by a vertical solid line. Since the mean resistance factors  $\bar{k}_i$  are assumed to independently and identically follow a normal distribution, the density of this distribution is also plotted.

## F.5 Change in resistance factor of each connector

The ageing of electrical connectors is caused by two processes. First the contact force can become smaller by the creeping of the conductor material in the connection. If the contact force is smaller than a minimal contact force then the joint resistance will be significantly higher. The second process which influences the ageing of connectors concerns chemical reactions on constriction areas. Both ageing processes occur in parallel but with different intensities.

Through both processes the connector resistance increases (see Figure F.4). Generally the ageing behaviour of an electrical contact caused by chemical and physical changes at the constriction areas can be divided into different phases: during formation, stable constriction areas are developed; in the second phase of ageing, relative stability, the connector resistance increases only very little. This is the phase in which the heat cycle test occurs. A mathematical ageing model for this phase is created and the behaviour of every connector is analysed. Nevertheless, as a result, the power loss in the joint increases, as does the connector temperature as well. This is observed following the assessment in E.7.

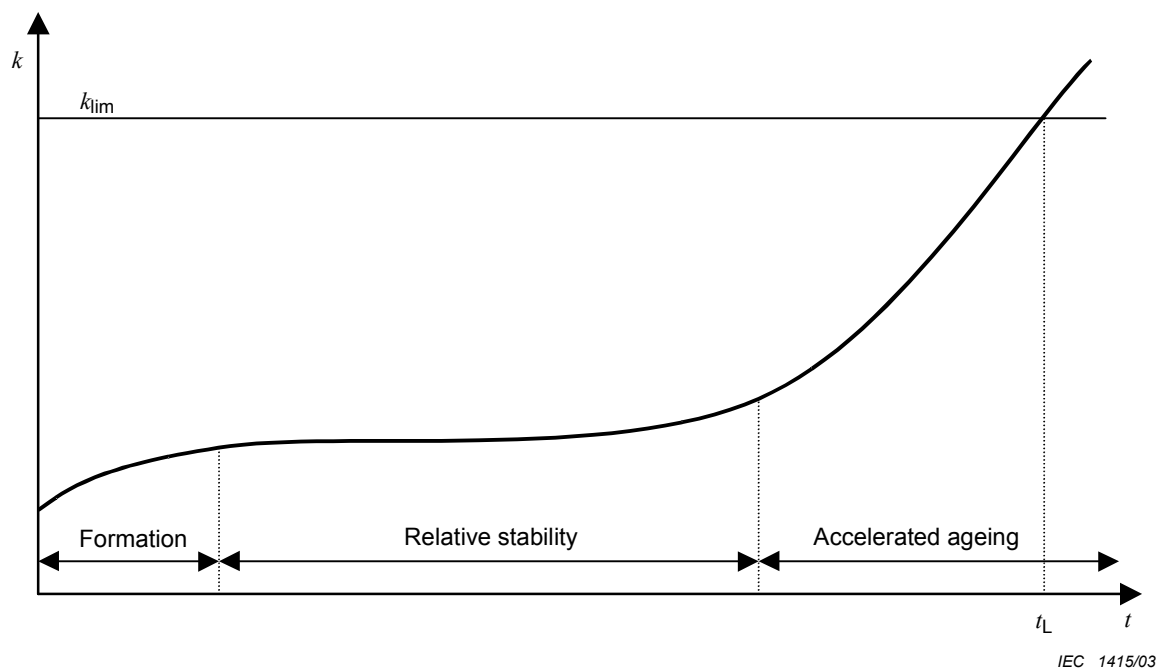

**Figure F.4 – Typical ageing behaviour of an electrical connector**  
( $k_{lim}$  limiting resistance factor;  $t_L$  lifetime)

In the third phase, accelerated ageing, the velocity of chemical processes increases due to the higher temperature. During accelerated ageing, the joint resistance increases considerably. This phase should not be reached during the test.

#### F.5.1 Line of best fit

To study the ageing behaviour of each connector during the last 11 measurements, the following ageing model is assumed. Each resistance factor  $k^{ij}$  depends on an unknown “connector  $i$  effect”,  $\tilde{a}_i$ , caused by the individual resistance behaviour of a connector to the test procedure, plus a “heat cycle effect”  $b_i \times j$ , which stands for the influence that the heat cycle corresponding to measurement  $j$  has on the resistance factor of connector  $i$ , plus an unknown error  $\varepsilon_{ij}$ , which represents both the amount of information in the data  $k^{ij}$  that cannot be explained by this model and additional errors, such as inaccuracies of measurement.

$$k^{ij} = \tilde{a}_i + \tilde{b}_i \times j + \varepsilon_{ij}$$

So a simple linear regression (line of best fit) on all resistance factors of connector  $i$  over the last 11 measurements is conducted. To simplify this, the dummy variable  $x_j = -5, \dots, +5$  (one value for each measurement  $j$ , e.g. representing measurement  $j = 4$  to measurement 14 for connectors of Class A, see Table F.7) is introduced and the model is transformed into the equivalent model  $k^{ij} = \tilde{a}_i + b_i \times x_j + \varepsilon_{ij}$ .

The purpose of this modeling is to try to estimate the mean response of the resistance factors, which is the true value of the resistance factor of connector  $i$  during measurement  $j$ . So the regression line, which is built by the fitted values  $\hat{k}^{ij} = \hat{a}_i + \hat{b}_i \times j = \tilde{a}_i + \hat{b}_i \times x_j$ , is an estimator for the mean response of the resistance factor of connector  $i$  during measurement  $j$ .

- $\hat{b}_i$  Estimated slope of the regression line, calculated from a simple linear regression on the resistance factors of connector  $i$  over the last 11 measurements, using the least squares method.

$$\hat{b}_i = \frac{1}{\sum_{j=4}^{14} x_j^2} \times \sum_{j=4}^{14} x_j \times k^{ij} = \frac{1}{110} \sum_{j=4}^{14} x_j \times k^{ij}, \quad \hat{a}_i = \bar{k}_i$$

The variable  $\hat{b}_i$  is an estimator for the unknown slope of the regression line and its magnitude indicates the size of effect that the heat cycles have on the resistance factors of connector  $i$ .

The estimator for the “connector- $i$  effect”  $\tilde{a}_i$  can be found as the mean resistance factor  $\bar{k}_i$  of connector  $i$ .

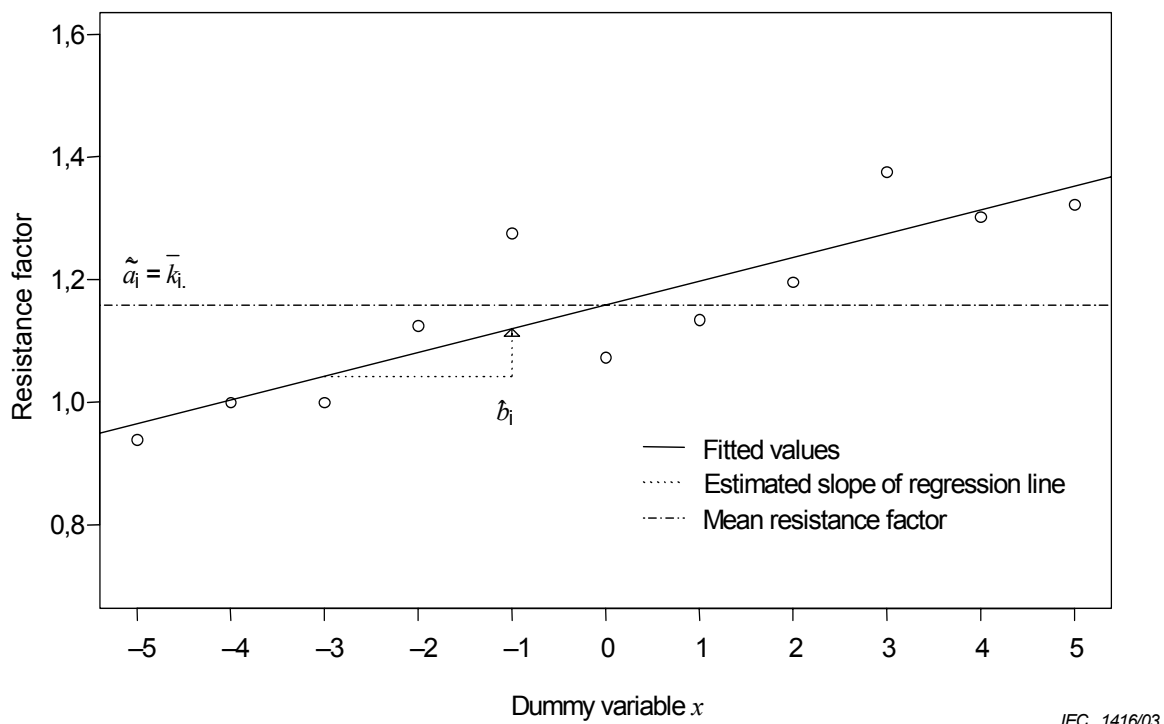

**Figure F.5 – Plot of the resistance factors, fitted values, estimated intercept and estimated slope**

Figure F.5 gives an example for the estimated slope  $\hat{b}_i$  and intercept  $\hat{a}_i$ , which represent the cross-sectional area of the “heat cycle effect” and the “connector effect” of connector  $i$ .

- $M^i$  Estimated relative change of the resistance factors of connector  $i$  over the last 11 measurements:

$$M^i = \frac{10 \times \hat{b}_i}{\bar{k}_i}$$

This quantity stands for the estimated total change of the resistance factors of connector  $i$ , standardized by the mean resistance factor of connector  $i$  over the last 11 measurements. Thus it is a dimensionless representative of the percentage of the value of the resistance factors of connector  $i$ , in relation to the mean resistance factor  $\bar{k}_i$ , that will vary over the last 11 measurements.

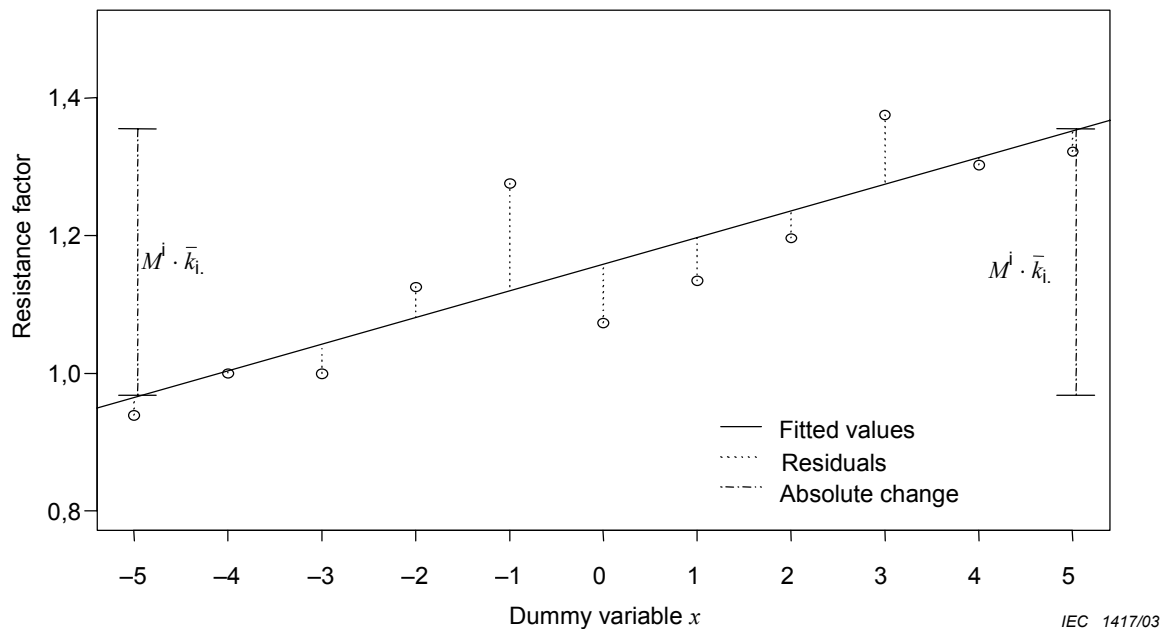

Figure F.6 – Plot of the fitted values, residuals and parameter  $M^i$

Figure F.6 gives an example for the absolute change  $M^i \times \bar{k}_i$ , which stands for the difference between the largest and the smallest fitted value of the resistance factor of connector  $i$ . The fitted values are plotted using a solid line, and the residuals are plotted using a dotted line.

#### F.5.2 Confidence interval

- $s^i$  Standard deviation of the residuals from the regression line, for connector  $i$ , calculated from the linear regression.

$$s^i = \sqrt{\frac{1}{9} \sum_{j=4}^{14} (k^{ij} - \bar{k}_i - \hat{b}_1 \times x_j)^2}$$

This parameter indicates the deviation of the resistance factors of connector  $i$  from the regression line.

- $\sigma^i$  Estimated maximum standard error of prediction of the mean response of the resistance factor for connector  $i$

$$\sigma^i = s^i \times \sqrt{\frac{1}{11} + \frac{\max(x_j^2)^i}{\sum_{j=4}^{14} x_j^2}} = \sqrt{\frac{1}{11} + \frac{25}{110}} \times s^i = 0,564 s^i$$

This variable estimates the largest standard error that will occur during the estimation of the true value of the resistance factor of connector  $i$ , during any measurement.

For the following quantities the assumption of independent, identical normal distribution of the residuals is necessary and realistic to use.



- $\delta^i$  Estimated maximum scatter of the mean response for connector  $i$

$$\delta^i = t_{9;0,95} \cdot \sigma^i = 1,833 \sigma^i$$

$\delta^i$  represents the smallest deviation from the mean response that the regression line will not exceed with a certain probability. It is based on a pointwise 90 % confidence interval for the mean response. Here the  $t_{9;0,95}$  quantile indicates that the pointwise 90 % C.I.:

$$\hat{k}^{ij} \pm t_{9;0,95} \times s^i \sqrt{\frac{1}{11} + \frac{x_j^2}{110}} = \bar{k}_i + \hat{b}_i \times x_j \pm t_{9;0,95} \times s^i \sqrt{\frac{1}{11} + \frac{x_j^2}{110}}$$

will cover the unknown mean response of connector  $i$  during measurement  $j$  with a probability of 90 %. It cannot be concluded that the C.I. will cover every observation of  $k^{ij}$  with a probability of 90 %. This C.I. will have its widest span at the points  $x = -5$  and  $x = +5$ , thus the maximum scatter will be reached at exactly these points. By substituting the estimated error of prediction

$$s^i \sqrt{\frac{1}{11} + \frac{x_j^2}{110}}$$

of the mean response of connector  $i$  during measurement  $j$  with the estimated maximum error of prediction

$$\sigma^i = s^i \sqrt{\frac{1}{11} + \frac{\max(x_j^2)}{110}}$$

the formula for  $\delta^i$  is obtained.

- $S^i$  Estimated relative maximum scatter of the mean response for connector  $i$

$$S^i = \frac{2 \times \delta^i}{\bar{k}_i} = \frac{2 \times t_{9;0,95} \sigma^i}{\bar{k}_i} = 2,07 \frac{s^i}{\bar{k}_i}$$

This quantity is calculated by taking two times the estimated maximum scatter of the mean response of connector  $i$  and standardizing it by the mean resistance factor of connector  $i$ . Thus it is a dimensionless variable and represents the maximum percentage of error of prediction which will happen during the estimation of the mean response of connector  $i$ .

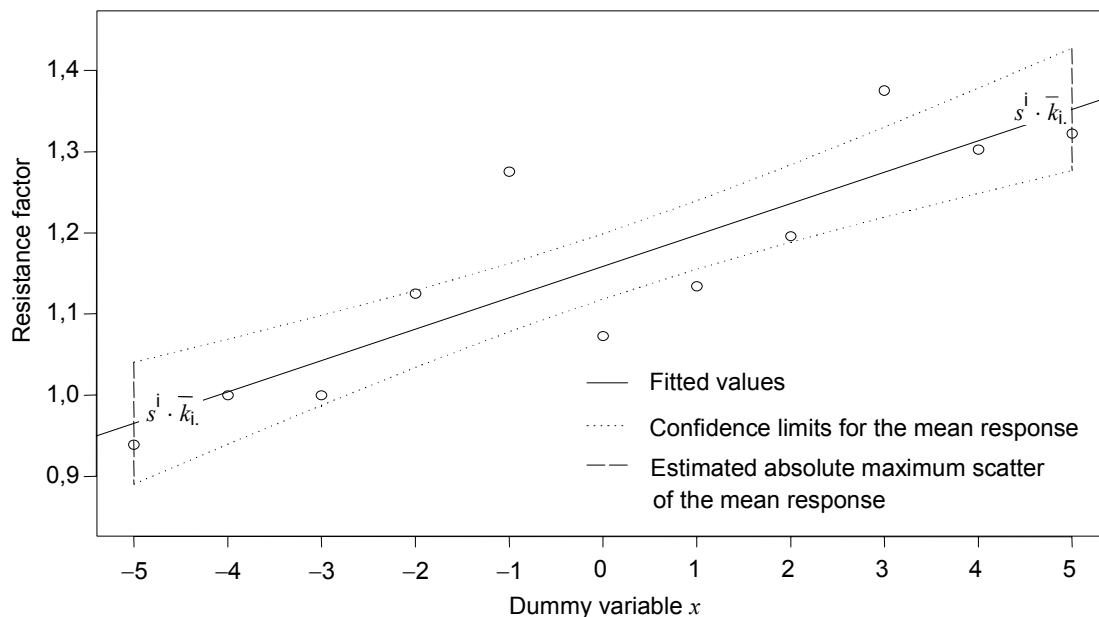

IEC 1418/03

**Figure F.7 – Plot of the pointwise 90 % confidence interval for the mean response and parameter  $S^i$**

Figure F.7 shows an example for the estimated absolute maximum scatter  $S^i \times \bar{k}_i$ , which is defined as the difference between the upper and the lower 90 % confidence limit of a pointwise 90 % confidence interval for the mean response of connector  $i$ . The fitted values and the confidence interval are also plotted, using a solid and a dotted line.

### F.5.3 Change in resistance factor $D^i$

- $D^i$  Relative statistical overall change of connector  $i$  over the last 11 measurements

$$D^i = |M^i| + S^i = \frac{|10\hat{b}_1| + 2,07 s^i}{\bar{k}_i}$$

This variable takes into account both the relative change and the relative scatter and adds them into one quantity. Large values of  $D^i$  may indicate a big change in the resistance factors or big scatter around the regression line of connector  $i$ . Interpretation of  $D^i$  is problematic though, since the two variables  $M^i$  and  $S^i$  are condensed into the univariate variable  $D^i$  and large values of  $D^i$  can be caused by two medium-sized values of  $M^i$  and  $S^i$ . On the other hand, it is possible to get the complete information of the change of the resistance behaviour during heat cycling of one connector in one single standardized figure, which is comparable with other connectors and other connector types. The variable  $D^i$  contains the most important result of the statistical assessment: 'stability' of a connector is shown when the slope of the regression line is low and additional errors that cannot be explained by this model, such as inaccuracies of measurement, do not occur.

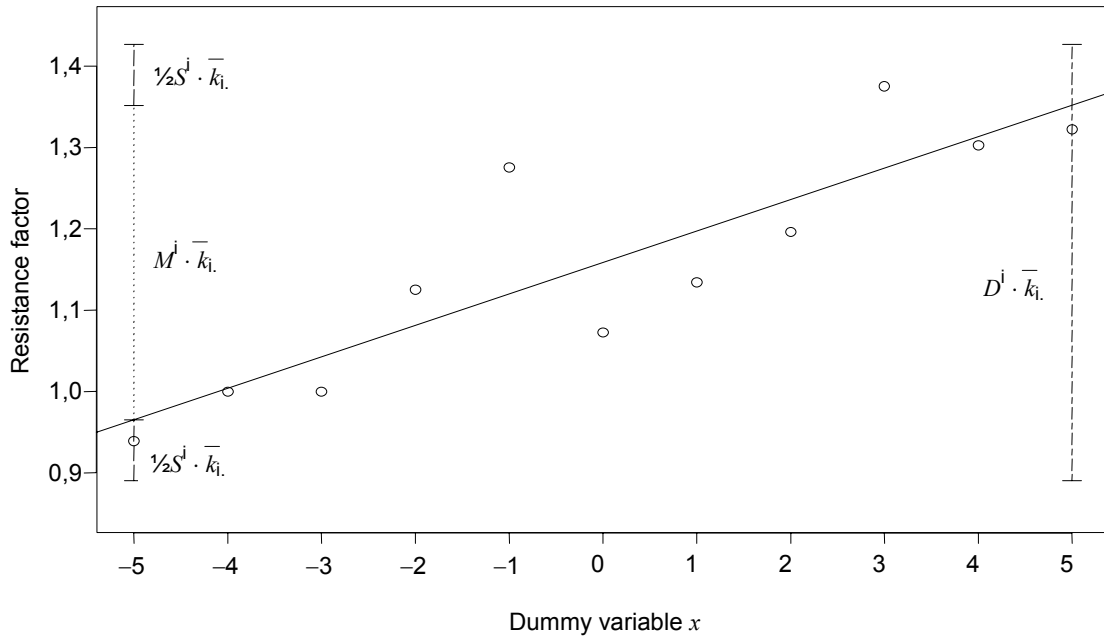

IEC 1419/03

Figure F.8 – Plot of parameters  $M^i$ ,  $S^i$  and  $D^i$  with regression line

Figure F.8 gives an example of the absolute statistical overall change  $D^i \times \bar{k}_i$ , which is defined as the sum of the absolute change  $M^i \times \bar{k}_i$  and the absolute maximum scatter  $S^i \times \bar{k}_i$ . The regression line – or the line of best fit – is also plotted, using a solid line.

## F.6 Resistance factor ratio

Table F.8 – Number of resistance factor ratios for connectors of Class A

Measurement <i>j</i> of Class A	Connector 1	Connector 2	Connector 3	Connector 4	Connector 5	Connector 6
1	1	1	1	1	1	1
2	$\lambda_{1,2}$	$\lambda_{2,2}$	$\lambda_{3,2}$	$\lambda_{4,2}$	$\lambda_{5,2}$	$\lambda_{6,2}$
3	$\lambda_{1,3}$	$\lambda_{2,3}$	$\lambda_{3,3}$	$\lambda_{4,3}$	$\lambda_{5,3}$	$\lambda_{6,3}$
4	$\lambda_{1,4}$	$\lambda_{2,4}$	$\lambda_{3,4}$	$\lambda_{4,4}$	$\lambda_{5,4}$	$\lambda_{6,4}$
5	$\lambda_{1,5}$	$\lambda_{2,5}$	$\lambda_{3,5}$	$\lambda_{4,5}$	$\lambda_{5,5}$	$\lambda_{6,5}$
6	$\lambda_{1,6}$	$\lambda_{2,6}$	$\lambda_{3,6}$	$\lambda_{4,6}$	$\lambda_{5,6}$	$\lambda_{6,6}$
7	$\lambda_{1,7}$	$\lambda_{2,7}$	$\lambda_{3,7}$	$\lambda_{4,7}$	$\lambda_{5,7}$	$\lambda_{6,7}$
8	$\lambda_{1,8}$	$\lambda_{2,8}$	$\lambda_{3,8}$	$\lambda_{4,8}$	$\lambda_{5,8}$	$\lambda_{6,8}$
9	$\lambda_{1,9}$	$\lambda_{2,9}$	$\lambda_{3,9}$	$\lambda_{4,9}$	$\lambda_{5,9}$	$\lambda_{6,9}$
10	$\lambda_{1,10}$	$\lambda_{2,10}$	$\lambda_{3,10}$	$\lambda_{4,10}$	$\lambda_{5,10}$	$\lambda_{6,10}$
11	$\lambda_{1,11}$	$\lambda_{2,11}$	$\lambda_{3,11}$	$\lambda_{4,11}$	$\lambda_{5,11}$	$\lambda_{6,11}$
12	$\lambda_{1,12}$	$\lambda_{2,12}$	$\lambda_{3,12}$	$\lambda_{4,12}$	$\lambda_{5,12}$	$\lambda_{6,12}$
13	$\lambda_{1,13}$	$\lambda_{2,13}$	$\lambda_{3,13}$	$\lambda_{4,13}$	$\lambda_{5,13}$	$\lambda_{6,13}$
14	$\lambda_{1,14}$	$\lambda_{2,14}$	$\lambda_{3,14}$	$\lambda_{4,14}$	$\lambda_{5,14}$	$\lambda_{6,14}$

This ratio indicates the relative change of the resistance factors of every individual connector *i* during every measurement *j* related to the initial resistance factor before heat cycle 1. For Class A connectors, 78  $\lambda$ -values shall be calculated and recorded (see Table F.8). For Class B connectors, 66 values are necessary.

$$\lambda^{ij} = \frac{k^{ij}}{k^{i1}}$$

## F.7 Maximum temperature $\theta_{\max}$

This part of the assessment is not related to the measurement of the 'cold resistance' near ambient temperature as done for the calculation of resistance factors. This part of the assessment is related to the temperature behaviour of connector *i* during any stage of heat cycling, when the maximum temperature is reached. Comparing this temperature with the simultaneously recorded temperature of the reference conductor (which has a stable resistance) gives a rough idea about the 'hot resistance' of each individual connector. Temperature measurements will have been recorded on each connector and on the reference conductor on the heat cycle prior to, or following the resistance measurement.

Table F.9 – Recorded maximum temperatures during heat cycling

$i \rightarrow$	Connector 1	Connector 2	Connector 3	Connector 4	Connector 5	Connector 6
Connector <sup>a</sup>	$\theta_{1,max}$	$\theta_{2,max}$	$\theta_{3,max}$	$\theta_{4,max}$	$\theta_{5,max}$	$\theta_{6,max}$
Reference <sup>b</sup>	$\theta_{1,ref}$	$\theta_{2,ref}$	$\theta_{3,ref}$	$\theta_{4,ref}$	$\theta_{5,ref}$	$\theta_{6,ref}$
<sup>a</sup> Maximum connector temperature during heat cycling. <sup>b</sup> Reference conductor temperature measured at the same time as <sup>a</sup> .						

## Annex G (informative)

### Explanation of the temperature profile

#### G.1 General

A cable, with extruded insulation, can withstand a maximum continuous temperature of 90 °C. The cable can also withstand a conductor temperature of up to 250 °C during short-circuits in service. The temperature of a connector in a cable joint is similar to the temperature of the cable conductor. A cable joint should not limit the current-carrying capacity of the cable under normal operation or under short-circuit conditions. The test has to be carried out on a bare conductor in order to make the conditions under test independent of the insulation.

The connector will normally be at a temperature lower than the conductor during the test, depending on its design, resistance and heat dissipation. In order to accelerate the test conditions and to represent the situation in a joint, the temperature of the connector must be higher than its temperature in the joint during service. A temperature of 100 °C (10 K higher than the conductor temperature) and a steady-state time of 10 min have been chosen as the test conditions. If the connector temperature is greater than 100 °C when the temperature of the reference conductor is 120 °C, then the reference temperature is 120 °C. If the connector temperature is less than 100 °C, then the reference conductor temperature is increased until the connectors reach 100 °C with an upper limit of 140 °C on the reference conductor. In this way, the connector temperature during the test will simulate the maximum connector temperature in the joint. The steady-state time of 10 min is to ensure that the connector will reach a certain degree of ageing at a known elevated temperature.

In the case of IPCs, the temperature for the connectors is chosen to be 10 K above maximum service temperature for the cable, instead of 100 °C.

#### G.2 Heat cycle

The main steps are explained below.

The first heat cycle is to determine the reference conductor temperature to be used during cycling and also to identify the median connector.

Find the steady-state current that gives 120 °C on the reference conductor. Identify the median connector.

- a) If the temperature of the median connector is  $\geq 100$  °C,  $\theta_R = 120$  °C.
- b) If the temperature of the median connector is  $< 100$  °C, then increase the current until the temperature of the median connector reaches 100 °C. However, the temperature of the reference conductor should not exceed 140 °C. In this way  $\theta_R$  is found.

In the case of IPCs, the median connector temperature should be 10 K above maximum service temperature of the cable.

The second heat cycle is to determine the heat cycle duration and temperature profile to be used during subsequent cycles. A current is circulated in the test loop until the reference conductor temperature reaches  $\theta_R$  with a tolerance of  ${}^+_0^6$  K and the median connector is stable within a band of 2 K over a 10 min period.

An accelerated current may be used to shorten the heating period. The duration of this higher current is given in Table 1. The current is then regulated or decreased to ensure stable conditions during the control period. It may be necessary to use more than one cycle to determine the temperature profile.

The reference conductor temperature is the control parameter for the temperature profile during the heat cycle test. In this way, any change in the ambient temperature will not affect the temperature profile of the reference conductor.

The temperature-time profile determined in this way is recorded and used for all subsequent cycles.

## Annex H (informative)

### Explanation of the statistical method of assessing results of tests on electrical connectors

#### H.1 History

The wide divergence between different national test methods for electrical connectors made it difficult for the user to compare, evaluate and accept results from tests according to different standards. In the process of introducing new products, it was sometimes necessary for the manufacturers to present test reports according to all relevant standards. To overcome these problems, a decision was made to establish a working group to make an internationally accepted standard with a well defined testing procedure and an assessment that was reproducible. The result of this work, IEC 61238-1, was presented in 1993.

The various testing standards considered during the preparation of this standard were based on temperature cycles and most of them included the application of short-circuit currents. The requirements and acceptance criteria were for the resistances to be stable. Different methods were used to define the stability during the short period of testing.

The statistical method of assessing test results described in this standard is mainly based on a compromise between the Italian Standard CEI 20-28 and the British Standard BS 4579: Part 3. Early in the discussions it was agreed to adopt a statistical method of evaluating the trend of electrical resistances instead of the more traditional deterministic methods. Several tests were carried out to find the similarities and differences between the two standards. The aim was to find a method of statistical assessment that would be relevant for a test with 1 000 heat cycles. The Italian Standard requires 1500 cycles with resistance measurements every 60 cycles during the last 600 cycles and six short-circuit current tests after 500 cycles, while the British standard requires 2000 cycles with resistance measurements every 100 cycles and three short-circuit current tests prior to heat cycling.

#### H.2 Short examination of the assessment methods of IEC 61238-1 compared with the Italian Standard CEI 20-28 and the British Standard BS 4579-3

The different statistical evaluations should be viewed as a part of the complete assessment procedure. All three standards require six identical specimens to be installed in a test loop and 11 resistance measurements constitute the basis for the statistical assessment. It should be noted that the formula letters in each standard may have different meanings. Table H.1 lists the various connector characteristics examined for this standard.

The main difference between the Italian and the British regression analysis is that the former, except for temperature requirements, assesses the six specimens as a group whereas in the British standard each specimen is assessed individually.

The individual regression analysis, which is incorporated in BS 4579: Part 3 and also adapted in this standard, is essential to provide adequate sensitivity to the change of resistance for a single sample. The analysis looks at the scatter of measurements about the line of best fit. However, the method is sensitive to anomalous readings, which may be a merit of the test as it can detect the onset of deterioration. The possibility that incorrect readings may affect the analysis should also be considered.



Group regression analysis as specified in the Italian Standard CEI 20-28 is a sensitive indicator of scatter and has the advantage of taking into account all 66 measurements. The method responds to differences between samples and to the change of resistance for particular samples. However, the method is less sensitive to the instability of a single specimen.

This standard formula for mean scatter is a group regression analysis based on the standard deviation between the mean of the six groups of specimen values averaged over 11 measurements. The Italian regression method is based on the calculation of mean values of the six specimens obtained for each of the 11 measurements.

The group regression analysis is a verification of whether or not the tested connectors belong to the same family.

### H.3 The IEC 61238-1 method of assessing test results

It was considered advantageous to introduce the “relative resistance”  $k$  so that the analysis would be independent of the absolute value of connector resistance.  $k$  is the relationship between the resistance of a connector and an equivalent length of the conductor. The adoption of  $k$  is also expected to give improved measurement reproducibility.

Other parameters that shall be calculated include:

- the initial scatter  $\delta$  between the initial six values of  $k$  before the heat cycling;
- the mean scatter  $\beta$  between the six values of  $k$  averaged over the last 11 measurements. The assessment verifies that the connectors behave in the same way and that they belong to the same “family”;
- the change in resistance factor  $D$ , which shows the change of the resistance factor  $k$  for each connector over the last 11 measurements. Statistical methods are used to assess the probability that the change of resistance will not exceed the specified value;
- the resistance factor ratio  $\lambda$ , which shows the relationship between the resistance at any stage of the measurements and the initial resistance;
- the maximum temperature  $\theta_{\max}$  of the test objects.

The selection of assessment criteria and values was made after evaluating test results and experience from different laboratories and countries.

At an early stage during the development of this standard,  $k$  itself was included as one of the acceptance criteria together with the change in  $k$  due to the short-circuits. To reduce the number of acceptance criteria, a decision was taken to exclude these parameters.

Table H.1 – Summary of requirements

Requirement	IEC 61238-1
1. The connectors shall not overheat	For each specimen the temperature of the connectors during heat cycling shall not exceed that of the reference conductor
2. The resistances shall not change excessively as a result of the short-circuit test	The resistance factor ratio $\lambda$ shall not exceed 2,0
3. The six specimens shall be similar in resistance	The initial scatter $\delta$ between the six values of $k$ before heat cycling shall not exceed the value 0,3
4. The resistance shall not change excessively during heat cycles	The mean scatter $\beta$ shall not exceed the value 0,3 The change in resistance factor $D$ shall not exceed 0,15
5. Mechanical tensile. No slipping shall occur as a result of the mechanical tensile test	Aluminium: $40 \times A$ : Maximum 20 000 N Copper : $60 \times A$ : Maximum 20 000 N $A$ = nominal cross-section area in mm <sup>2</sup>

## Annex ZA (normative)

### Normative references to international publications with their corresponding European publications

This European Standard incorporates by dated or undated reference, provisions from other publications. These normative references are cited at the appropriate places in the text and the publications are listed hereafter. For dated references, subsequent amendments to or revisions of any of these publications apply to this European Standard only when incorporated in it by amendment or revision. For undated references the latest edition of the publication referred to applies (including amendments).

NOTE When an international publication has been modified by common modifications, indicated by (mod), the relevant EN/HD applies.

<u>Publication</u>	<u>Year</u>	<u>Title</u>	<u>EN/HD</u>	<u>Year</u>
IEC 60050-461	1984	International Electrotechnical Vocabulary (IEV) Chapter 461: Electric cables	-	-
A1	1993		-	-
IEC 60228 (mod) + IEC 60228A (mod)	1978 1982	Conductors of insulated cables First supplement: Guide to the dimensional limits of circular conductors	HD 383 S2	1986
IEC 60493-1	1974	Guide for the statistical analysis of ageing test data Part 1: Methods based on mean values of normally distributed test results	-	-

## Bibliography

IEC 60694:1996, *Common specifications for high-voltage switchgear and controlgear standards*

NOTE Harmonized as EN 60694:1996 (not modified).

IEC 60949:1988, *Calculation of thermally permissible short-circuit currents, taking into account non-adiabatic heating effects*

Italian Standard CEI 20-28:1998, *Connettori per cavi d'energia*

British Standard BS 4579: Part 3: 1976, *Specification for the performance of mechanical and compression joints in electric cable and wire connectors. Mechanical and compression joints in aluminium conductors*

---



---

---

## BSI — British Standards Institution

BSI is the independent national body responsible for preparing British Standards. It presents the UK view on standards in Europe and at the international level. It is incorporated by Royal Charter.

### Revisions

British Standards are updated by amendment or revision. Users of British Standards should make sure that they possess the latest amendments or editions.

It is the constant aim of BSI to improve the quality of our products and services. We would be grateful if anyone finding an inaccuracy or ambiguity while using this British Standard would inform the Secretary of the technical committee responsible, the identity of which can be found on the inside front cover.  
Tel: +44 (0)20 8996 9000. Fax: +44 (0)20 8996 7400.

BSI offers members an individual updating service called PLUS which ensures that subscribers automatically receive the latest editions of standards.

### Buying standards

Orders for all BSI, international and foreign standards publications should be addressed to Customer Services. Tel: +44 (0)20 8996 9001.  
Fax: +44 (0)20 8996 7001. Email: [orders@bsi-global.com](mailto:orders@bsi-global.com). Standards are also available from the BSI website at <http://www.bsi-global.com>.

In response to orders for international standards, it is BSI policy to supply the BSI implementation of those that have been published as British Standards, unless otherwise requested.

### Information on standards

BSI provides a wide range of information on national, European and international standards through its Library and its Technical Help to Exporters Service. Various BSI electronic information services are also available which give details on all its products and services. Contact the Information Centre.  
Tel: +44 (0)20 8996 7111. Fax: +44 (0)20 8996 7048. Email: [info@bsi-global.com](mailto:info@bsi-global.com).

Subscribing members of BSI are kept up to date with standards developments and receive substantial discounts on the purchase price of standards. For details of these and other benefits contact Membership Administration.  
Tel: +44 (0)20 8996 7002. Fax: +44 (0)20 8996 7001.  
Email: [membership@bsi-global.com](mailto:membership@bsi-global.com).

Information regarding online access to British Standards via British Standards Online can be found at <http://www.bsi-global.com/bsonline>.

Further information about BSI is available on the BSI website at <http://www.bsi-global.com>.

### Copyright

Copyright subsists in all BSI publications. BSI also holds the copyright, in the UK, of the publications of the international standardization bodies. Except as permitted under the Copyright, Designs and Patents Act 1988 no extract may be reproduced, stored in a retrieval system or transmitted in any form or by any means – electronic, photocopying, recording or otherwise – without prior written permission from BSI.

This does not preclude the free use, in the course of implementing the standard, of necessary details such as symbols, and size, type or grade designations. If these details are to be used for any other purpose than implementation then the prior written permission of BSI must be obtained.

Details and advice can be obtained from the Copyright & Licensing Manager.  
Tel: +44 (0)20 8996 7070. Fax: +44 (0)20 8996 7553.  
Email: [copyright@bsi-global.com](mailto:copyright@bsi-global.com).