

BS EN 61188-7:2009



BSI British Standards

Printed boards and printed board assemblies – Design and use —

Part 7: Electronic component zero orientation for CAD library construction

NO COPYING WITHOUT BSI PERMISSION EXCEPT AS PERMITTED BY COPYRIGHT LAW

raising standards worldwide™

BSI
British Standards

National foreword

This British Standard is the UK implementation of EN 61188-7:2009. It is identical to IEC 61188-7:2009.

The UK participation in its preparation was entrusted to Technical Committee EPL/501, Electronic assembly technology.

A list of organizations represented on this committee can be obtained on request to its secretary.

This publication does not purport to include all the necessary provisions of a contract. Users are responsible for its correct application.

© BSI 2009

ISBN 978 0 580 59866 1

ICS 31.180

Compliance with a British Standard cannot confer immunity from legal obligations.

This British Standard was published under the authority of the Standards Policy and Strategy Committee on 30 September 2009

Amendments issued since publication

| Amd. No. | Date | Text affected |
|-----------------|-------------|----------------------|
|-----------------|-------------|----------------------|

**Printed boards and printed board assemblies -
Design and use -
Part 7: Electronic component zero orientation
for CAD library construction
(IEC 61188-7:2009)**

Cartes imprimées
et cartes imprimées équipées -
Conception et utilisation -
Partie 7: Orientation nulle des composants
électroniques pour l'élaboration
de la bibliothèque CAO
(CEI 61188-7:2009)

Leiterplatten und Flachbaugruppen -
Konstruktion und Anwendung -
Teil 7: Nullorientierung elektronischer
Baelemente für CAD-Bibliotheksaufbau
(IEC 61188-7:2009)

This European Standard was approved by CENELEC on 2009-06-01. CENELEC members are bound to comply with the CEN/CENELEC Internal Regulations which stipulate the conditions for giving this European Standard the status of a national standard without any alteration.

Up-to-date lists and bibliographical references concerning such national standards may be obtained on application to the Central Secretariat or to any CENELEC member.

This European Standard exists in three official versions (English, French, German). A version in any other language made by translation under the responsibility of a CENELEC member into its own language and notified to the Central Secretariat has the same status as the official versions.

CENELEC members are the national electrotechnical committees of Austria, Belgium, Bulgaria, Cyprus, the Czech Republic, Denmark, Estonia, Finland, France, Germany, Greece, Hungary, Iceland, Ireland, Italy, Latvia, Lithuania, Luxembourg, Malta, the Netherlands, Norway, Poland, Portugal, Romania, Slovakia, Slovenia, Spain, Sweden, Switzerland and the United Kingdom.

CENELEC

European Committee for Electrotechnical Standardization
Comité Européen de Normalisation Electrotechnique
Europäisches Komitee für Elektrotechnische Normung

Central Secretariat: Avenue Marnix 17, B - 1000 Brussels

Foreword

The text of document 91/854/FDIS, future edition 1 of IEC 61188-7, prepared by IEC TC 91, Electronics assembly technology, was submitted to the IEC-CENELEC parallel vote and was approved by CENELEC as EN 61188-7 on 2009-06-01.

The following dates were fixed:

- latest date by which the EN has to be implemented
at national level by publication of an identical
national standard or by endorsement (dop) 2010-03-01
- latest date by which the national standards conflicting
with the EN have to be withdrawn (dow) 2012-06-01

Annex ZA has been added by CENELEC.

Endorsement notice

The text of the International Standard IEC 61188-7:2009 was approved by CENELEC as a European Standard without any modification.

Annex ZA (normative)

Normative references to international publications with their corresponding European publications

The following referenced documents are indispensable for the application of this document. For dated references, only the edition cited applies. For undated references, the latest edition of the referenced document (including any amendments) applies.

NOTE When an international publication has been modified by common modifications, indicated by (mod), the relevant EN/HD applies.

| <u>Publication</u> | <u>Year</u> | <u>Title</u> | <u>EN/HD</u> | <u>Year</u> |
|--------------------|-----------------|---|--------------|--------------------|
| IEC 61182-2 | - ¹⁾ | Printed board assembly products - Manufacturing description data and transfer methodology - Part 2: Generic requirements | - | - |
| IEC 61188-5-1 | - ¹⁾ | Printed boards and printed board assemblies - Design and use - Part 5-1: Attachment (land/joint) considerations - Generic requirements | EN 61188-5-1 | 2002 ²⁾ |
| IEC 61188-5-2 | - ¹⁾ | Printed boards and printed board assemblies - Design and use - Part 5-2: Attachment (land/joint) considerations - Discrete components | EN 61188-5-2 | 2003 ²⁾ |
| IEC 61188-5-3 | - ¹⁾ | Printed boards and printed board assemblies - Design and use - Part 5-3: Attachment (land/joint) considerations - Components with gull-wing leads on two sides | EN 61188-5-3 | 2007 ²⁾ |
| IEC 61188-5-4 | - ¹⁾ | Printed boards and printed board assemblies - Design and use - Part 5-4: Attachment (land/joint) consideration - Components with J-leads on two sides | EN 61188-5-4 | 2007 ²⁾ |
| IEC 61188-5-5 | - ¹⁾ | Printed boards and printed board assemblies - Design and use - Part 5-5: Attachment (land/joint) considerations - Components with gull-wing leads on four sides | EN 61188-5-5 | 2007 ²⁾ |
| IEC 61188-5-6 | - ¹⁾ | Printed boards and printed board assemblies - Design and use - Part 5-6: Attachment (land/joint) considerations - Chip carriers with J-leads on four sides | EN 61188-5-6 | 2003 ²⁾ |
| IEC 61188-5-8 | - ¹⁾ | Printed boards and printed board assemblies - Design and use - Part 5-8: Attachment (land/joint) considerations - Area array components (BGA, FBGA, CGA, LGA) | EN 61188-5-8 | 2008 ²⁾ |

¹⁾ Undated reference.

²⁾ Valid edition at date of issue.

CONTENTS

| | |
|--|----|
| FOREWORD..... | 3 |
| INTRODUCTION..... | 5 |
| 1 Scope..... | 6 |
| 2 Normative references | 6 |
| 3 Basic rules | 6 |
| 3.1 Common rules | 6 |
| 3.2 General basic rules | 7 |
| 3.3 Level A basic rule..... | 7 |
| 3.4 Level B basic rules | 7 |
| 3.5 File description definition..... | 7 |
| 3.6 Component orientations | 8 |
| 4 Origin point of land-pattern | 16 |
| 4.1 General..... | 16 |
| 4.2 Surface mount components | 16 |
| 4.3 Through-hole leaded components..... | 17 |
| 5 Land pattern to foot print comparison | 18 |
| 6 Components with one terminal..... | 18 |
| 6.1 Surface mount components | 18 |
| 6.2 Through-hole leaded components..... | 18 |
| Figure 1 – Example of Level A orientation concepts..... | 8 |
| Figure 2 – Connector and switch library symbol examples | 17 |
| Figure 3 – Through-hole components with terminal point of origin orientation | 17 |
| Figure 4 – Circular or square one terminal component | 18 |
| Figure 5 – Rectangular or oval one terminal component..... | 18 |
| Figure 6 – Surface mount components with one lead offset..... | 18 |
| Table 1 – Discrete component land pattern conventions | 9 |
| Table 2 – Diode and transistor land pattern conventions | 10 |
| Table 3 – Transistor and IC land pattern conventions | 11 |
| Table 4 – Integrated circuit packages land pattern conventions | 12 |
| Table 5 – Integrated circuit packages land pattern conventions | 13 |
| Table 6 – BGA land pattern conventions | 14 |
| Table 7 – Resistor array and connector land pattern conventions | 15 |
| Table 8 – Level A land pattern convention summary | 15 |
| Table 9 – Level B land pattern convention summary | 16 |

INTERNATIONAL ELECTROTECHNICAL COMMISSION

**PRINTED BOARDS AND PRINTED BOARD ASSEMBLIES –
DESIGN AND USE –****Part 7: Electronic component zero orientation
for CAD library construction**

FOREWORD

- 1) The International Electrotechnical Commission (IEC) is a worldwide organization for standardization comprising all national electrotechnical committees (IEC National Committees). The object of IEC is to promote international co-operation on all questions concerning standardization in the electrical and electronic fields. To this end and in addition to other activities, IEC publishes International Standards, Technical Specifications, Technical Reports, Publicly Available Specifications (PAS) and Guides (hereafter referred to as "IEC Publication(s)"). Their preparation is entrusted to technical committees; any IEC National Committee interested in the subject dealt with may participate in this preparatory work. International, governmental and non-governmental organizations liaising with the IEC also participate in this preparation. IEC collaborates closely with the International Organization for Standardization (ISO) in accordance with conditions determined by agreement between the two organizations.
- 2) The formal decisions or agreements of IEC on technical matters express, as nearly as possible, an international consensus of opinion on the relevant subjects since each technical committee has representation from all interested IEC National Committees.
- 3) IEC Publications have the form of recommendations for international use and are accepted by IEC National Committees in that sense. While all reasonable efforts are made to ensure that the technical content of IEC Publications is accurate, IEC cannot be held responsible for the way in which they are used or for any misinterpretation by any end user.
- 4) In order to promote international uniformity, IEC National Committees undertake to apply IEC Publications transparently to the maximum extent possible in their national and regional publications. Any divergence between any IEC Publication and the corresponding national or regional publication shall be clearly indicated in the latter.
- 5) IEC provides no marking procedure to indicate its approval and cannot be rendered responsible for any equipment declared to be in conformity with an IEC Publication.
- 6) All users should ensure that they have the latest edition of this publication.
- 7) No liability shall attach to IEC or its directors, employees, servants or agents including individual experts and members of its technical committees and IEC National Committees for any personal injury, property damage or other damage of any nature whatsoever, whether direct or indirect, or for costs (including legal fees) and expenses arising out of the publication, use of, or reliance upon, this IEC Publication or any other IEC Publications.
- 8) Attention is drawn to the Normative references cited in this publication. Use of the referenced publications is indispensable for the correct application of this publication.
- 9) Attention is drawn to the possibility that some of the elements of this IEC Publication may be the subject of patent rights. IEC shall not be held responsible for identifying any or all such patent rights.

International Standard IEC 61188-7 has been prepared by IEC technical committee 91: Electronics assembly technology.

The text of this standard is based on the following documents:

| | |
|-------------|------------------|
| FDIS | Report on voting |
| 91/854/FDIS | 91/866/RVD |

Full information on the voting for the approval of this standard can be found in the report on voting indicated in the above table.

This publication has been drafted in accordance with the ISO/IEC Directives, Part 2.

A list of all parts of the IEC 61188 series, under the general title *Printed boards and printed board assemblies – Design and use*, can be found on the IEC website.

The committee has decided that the contents of this publication will remain unchanged until the maintenance result date indicated on the IEC web site under "<http://webstore.iec.ch>" in the data related to the specific publication. At this date, the publication will be

- reconfirmed,
- withdrawn,
- replaced by a revised edition, or
- amended.

A bilingual version of this publication may be issued at a later date.

The contents of the corrigendum of July 2009 have been included in this copy.

INTRODUCTION

One of the factors of establishing a CAD library component description and land pattern standard is to adopt a fixed zero component orientation so that all CAD images are built with the same rotation for the purpose of assembly machine automation.

The land pattern standards clearly define all the properties necessary for standardization and acceptability of a one world CAD library. The main objective in defining a one world CAD library is to achieve the highest level of electronic product development automation. This encompasses all the processes involved from engineering to PCB layout to fabrication, assembly and test. The data format standards need this type of consistency in order to meet the efficiency that electronic data transfer can bring to the industry.

Many large firms have spent millions of dollars creating and implementing their own unique standards for their own electronic product development automation. These standards are proprietary to each firm and are not openly shared with the rest of the industry. This has resulted in massive duplication of effort costing the industry millions of man hours in waste and creating industry chaos and global non-standardization.

The industry associations responsible for component descriptions and tape and reel orientation have tried valiantly to influence the industry by making good standards that describe the component outlines and how they should be positioned in the delivery system to the equipment on the manufacturing floor. Suppliers of parts have either not adhered to the recommendations or have misunderstood the intent and provided their products in different orientations.

The Land pattern standards (IEC 61188-5-1, IEC 61188-5-2, IEC 61188-5-3, IEC 61188-5-4, IEC 61188-5-5, IEC 61188-5-6 and IEC 61188-5-8) put an end to the proprietary intellectual property and introduce a world standard so every electronics firm can benefit from electronic product development automation. The data format standards (IPC-2581 and IEC 61182-2) are an open database XML software code that is neutral to all the various CAD ASCII formats. For true machine automation to exist, the world desperately needs a neutral CAD database format that all PCB manufacturing machines can read.

The main purpose of creating the land pattern standards is to achieve reliable solder joint formation platforms; the reason for developing the data transfer structure is to improve the efficiency with which engineering intelligence is converted to manufacturing reality. Even if the neutral CAD format can drive all the manufacturing machines, it would be meaningless unless the component description standard for CAD land patterns was implemented with some consistency. Zero component orientation has a key role in machine automation.

The obvious choice for global standardization for EE hardware engineering, PCB design layout, manufacturing, assembly and testing processes is to incorporate the standard land pattern conventions. Any other option continues the confusion and additional manual hours of intervention in order to achieve the goals of automation. In addition, the ease of having one system export a file so that another system can accomplish the work may require unnecessary manipulation of the neutral format in order to meet the object of clear, unambiguous software code.

The design of any assembly will continue to permit arrangement and orientation of components at any orientation consistent with design standards. Starting from a commonly understood data capture concept will benefit the entire supply chain.

This standard defines angle and origin point of land-pattern for land-pattern designing.

PRINTED BOARDS AND PRINTED BOARD ASSEMBLIES – DESIGN AND USE –

Part 7: Electronic component zero orientation for CAD library construction

1 Scope

This part of IEC 61188 establishes a consistent technique for the description of electronic component orientation, and their land pattern geometries. This facilitates and encourages a common data capture and transfer methodology amongst and between global trading partners.

2 Normative references

The following referenced documents are indispensable for the application of this document. For dated references, only the edition cited applies. For undated references, the latest edition of the referenced document (including any amendments) applies.

IEC 61182-2, *Printed board assembly products – Manufacturing description data and transfer methodology – Part 2: Generic requirements*

IEC 61188-5-1, *Printed boards and printed board assemblies – Design and use – Part 5-1: Attachment (land/joint) considerations – Generic requirements*

IEC 61188-5-2, *Printed boards and printed board assemblies – Design and use – Part 5-2: Attachment (land/joint) considerations – Discrete components*

IEC 61188-5-3, *Printed boards and printed board assemblies – Design and use – Part 5-3: Attachment (land/joint) considerations – Components with gull-wing leads on two sides*

IEC 61188-5-4, *Printed boards and printed board assemblies – Design and use – Part 5-4: Attachment (land/joint) considerations – Components with J-leads on two sides*

IEC 61188-5-5, *Printed boards and printed board assemblies – Design and use – Part 5-5: Attachment (land/joint) considerations – Components with gull-wing leads on four sides*

IEC 61188-5-6, *Printed boards and printed board assemblies – Design and use – Part 5-6: Attachment (land/joint) considerations – Chip carriers with J-leads on four sides*

IEC 61188-5-8, *Printed boards and printed board assemblies – Design and use – Part 5-8: Attachment (land/joint) considerations – Area array components (BGA, FBGA, CGA, LGA)*

3 Basic rules

3.1 Common rules

Common rules are divided into two groups; level A and level B. The main difference between the rules is the original orientation within the CAD system library. This orientation may be any version that the designers finds useful including his own version, however when the information is transferred to an assembler the orientation shall be properly defined without ambiguity or shall be corrected in order that any variation between the different systems are

properly matched. This conversion of the CAD data to manufacturing information may include the datum of the board, fabrication panel or assembly array panel and will have the proper orientation of all components on the board no matter what library was used as the original input.

3.2 General basic rules

The following basic rules apply.

- Components and land-patterns are drawn in top view.
- The component point of origin is shown by + or x.
- The origin point of land-patterns may be different from the origin point of the placement.
- A circumscribing rectangle which contains the component body and land patterns (in top view) should be a part of the library component description. This rectangle is the courtyard that provides a minimum electrical and physical clearance for the part and the land pattern. The point of origin of the description should match that of the component and land pattern.
- The arrangement of land-patterns is fixed uniformly by the classification and the shape of components and is described in IEC 61188-5-1 through IEC 61188-5-8. The information for the land-patterns is independent from the angle in the component delivery system (tape, tray, tube etc.). The location of pin one in the land pattern or component description shall be identical with any polarization mark on the component. If other descriptions are used on the component data, (e.g., cathode, anode, base, emitter, collector, etc.) the library description shall assign an appropriate pin one designation.
- The component orientation shall position pin one as being on the left hand side of the component description.
- The component, land pattern and circumscribing rectangle descriptions, shall be identical in the computer library with each description using the same point of origin coordinates. It is recommended that the point of origin is the same as the way the component is positioned on the final design of the board which is normally by the centroid of the component body. Only the component rotation shall be altered to match the rules for level A or level B descriptions for components with more than two pins.

3.3 Level A basic rule

For level A the following basic rule applies.

- For level A type component descriptions for multiple leaded parts, pin one shall be left oriented as indicated in the basic rules, however, pin one shall be located at the upper or upper-left position.

3.4 Level B basic rules

For level B the following basic rule applies.

- For level B type component descriptions for multiple leaded parts pin one shall be left oriented per the basic rules however, pin one shall be located at the left or lower-left position.

3.5 File description definition

Since the basic rules allow two variations of levels in the description of the CAD system library, it is a mandatory requirement to define which level was used (level A or Level B) for the component descriptions in the data file. This information is a mandatory requirement in the Header of any file that incorporates land patterns using these principles of zero-based orientation. See Figure 1.

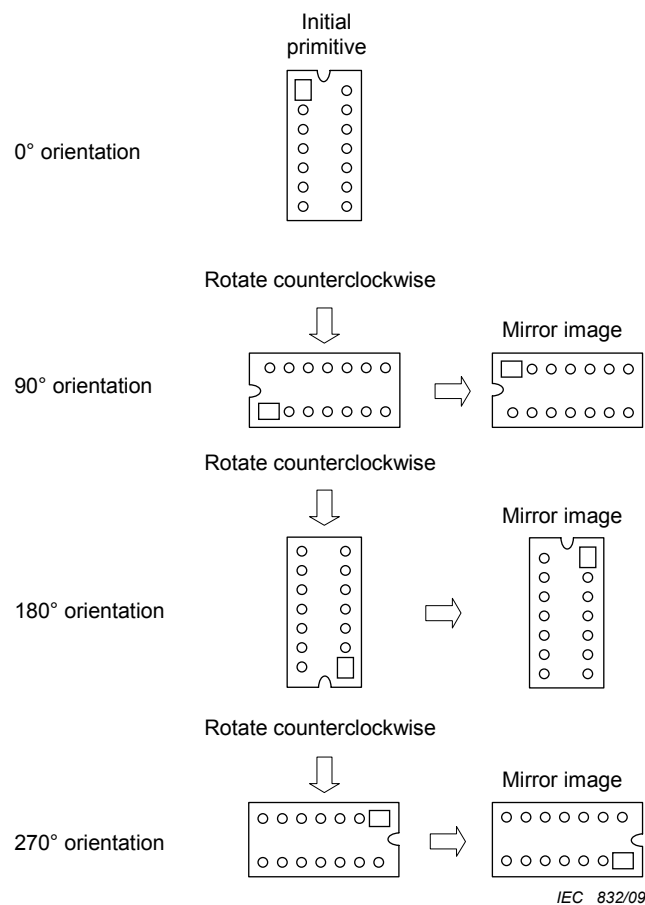

Figure 1 – Example of Level A orientation concepts

3.6 Component orientations

The zero component orientations expressed in this standard are defined in terms of the standard component CAD library with respect to a given PCB design. Recognizing that a single land pattern may be used for the same component part from different suppliers and that each component supplier may have different orientations on their reels or that the components may come in trays, there exists the possibility that the PCB designer loses the ability to reference a single land pattern if the zero rotation of a part is according to the method the component is delivered to the assembly machine.

Since the CAD library contains a single land pattern, the zero component rotation is thus defined according to the CAD library. Subsequently, component suppliers can identify the orientation of the parts on the reels by associating the placement of the part on the reel to zero orientations defined in IEC 61188-7. If pin 1 is at the lower left as defined by the pick and place machine tape and reel, for example, then the component on the reel is rotated 90° counterclockwise from the zero rotation given in IEC 61188-7. Standardizing the orientation of components for the installation and utilization of various packaging methods, such as tubes, trays or tapes and reels, among the variations of automated assembly equipment existing today is outside the scope of this document.

Table 1 through Table 7 show zero component rotations using the basic rules and rules for level A and level B component descriptions.

Table 1 – Discrete component land pattern conventions



| Package type | Component example | Level A | Level B |
|---------------------|---|--|---|
| Chip capacitor |  |  |  |
| Chip resistor |  |  |  |
| Chip inductor |  |  |  |
| Molded capacitor |  |  |  |
| Molded diode |  |  |  |
| Molded inductor |  |  |  |
| Precision wirewound |  |  |  |

Table 2 – Diode and transistor land pattern conventions





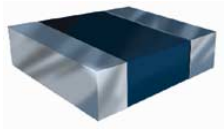
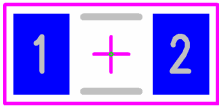
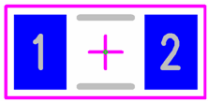
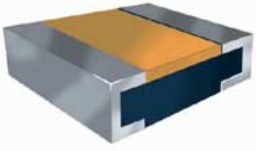
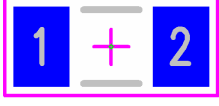
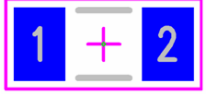
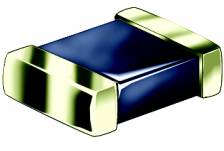
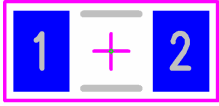
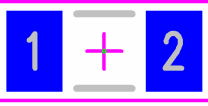

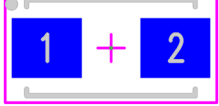
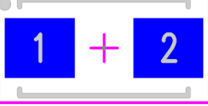
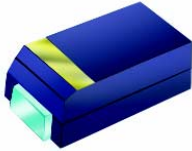
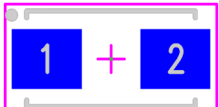
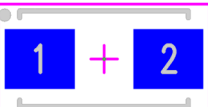
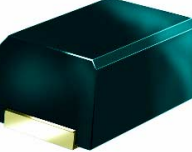
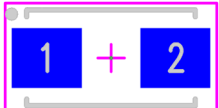
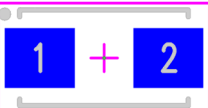
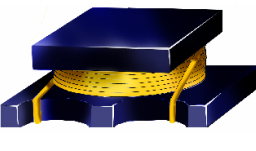
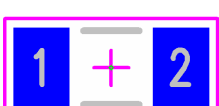
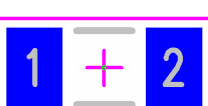

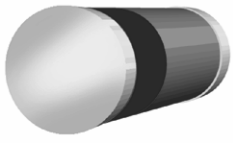
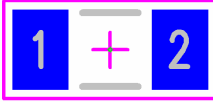
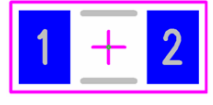
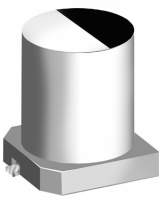
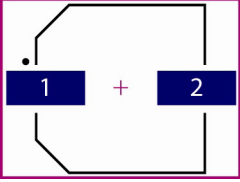
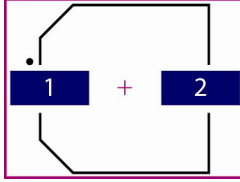

| Package type | Component example | Level A | Level B |
|---------------------------------|---|---|---|
| Diode (MELF) |  |  |  |
| Resistor (MELF) |  |  |  |
| Aluminum electrolytic capacitor |  |  |  |
| SOT23-3 |  |  |  |
| SOT23-5 |  |  |  |
| SOT343 |  |  |  |
| SOT223 |  |  |  |

Table 3 – Transistor and IC land pattern conventions

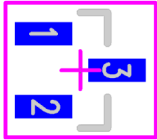
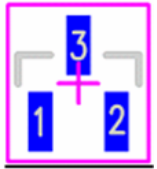

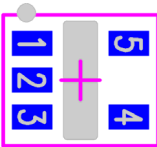
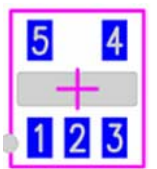

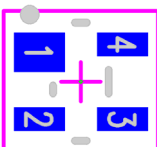
| Package type | Component example | Level A | Level B |
|------------------------------------|---|--|---|
| TO252 (DPAK) |  |  |  |
| SOIC, SOP, and SSOP |  |  |  |
| TSSOP |  |  |  |
| SOJ |  |  |  |
| Square QFP Pin 1 in corner |  |  |  |
| Rectangular QFP Pin 1 in corner |  |  |  |

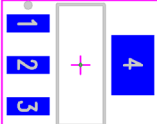
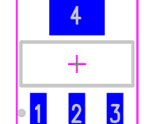
Table 4 – Integrated circuit packages land pattern conventions

| Package Type | Component Example | Level A | Level B |
|---|---|--|---|
| Bump QFP Pin 1 in corner |  |  |  |
| Bump QFP Pin 1 in middle |  |  |  |
| Ceramic flat package |  |  |  |
| CQFP (ceramic quad flat package) |  |  |  |
| PLCC (QFJ) square J leaded Pin 1 in middle |  |  |  |

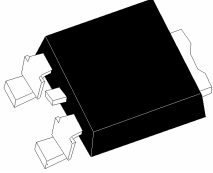
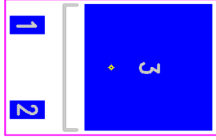
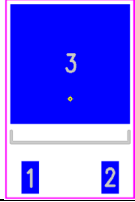
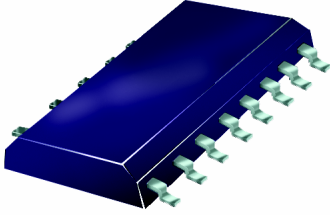
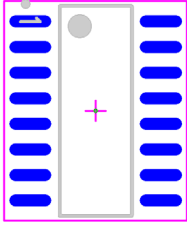
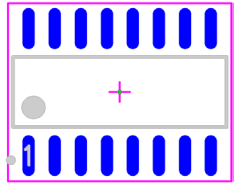
Table 5 – Integrated circuit packages land pattern conventions

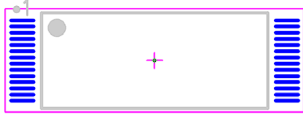
| Package Type | Component Example | Level A | Level B |
|---|---|--|---|
| PLCC (QFJ) rectangular J leaded Pin 1 in middle |  |  |  |
| LCC square Pin 1 in middle |  |  |  |
| QFN square |  |  |  |
| QFN rectangular |  |  |  |

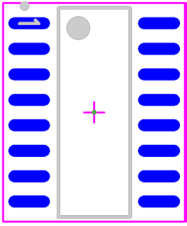
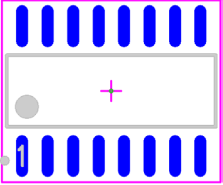
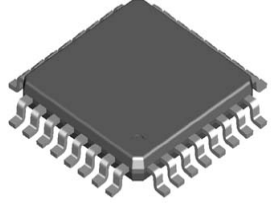
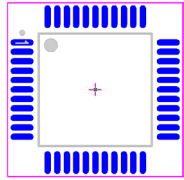
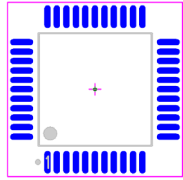
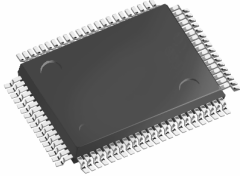
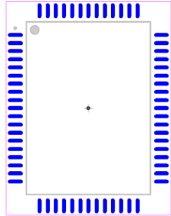
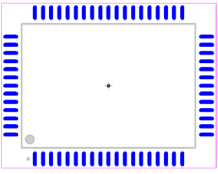
Table 6 – BGA land pattern conventions

| Package type | Component example | Level A | Level B |
|-----------------|---|---|---|
| BGA square |  |  |  |
| BGA rectangular |  <p>Numeric designations for horizontal grid</p> <p>Alpha designations for vertical grid (letters I, O, Q and S not used)</p> <p>-s- TYP</p> <p>-s- TYP</p> |  |  |

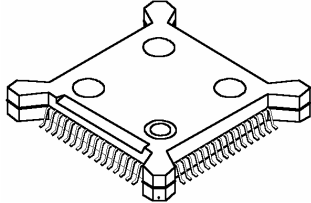
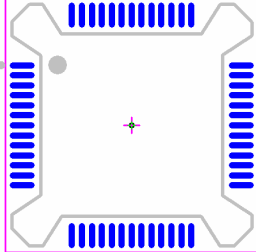
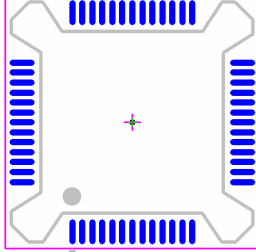
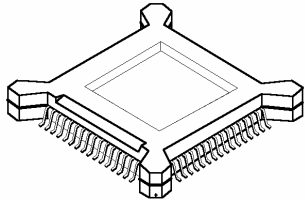
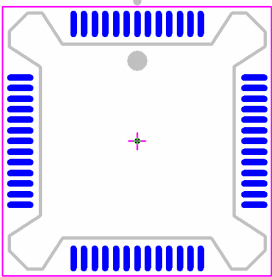
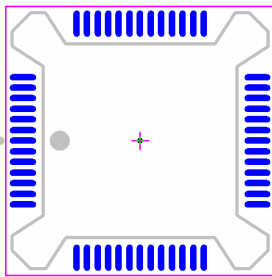
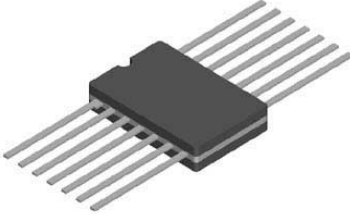
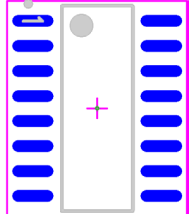
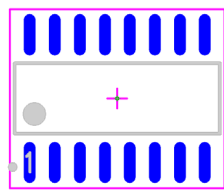
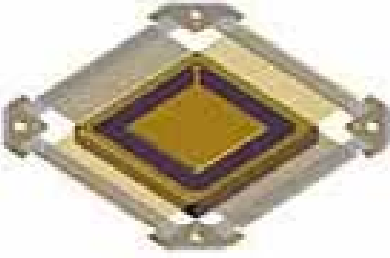
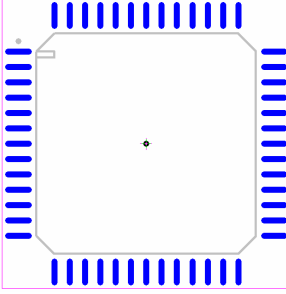
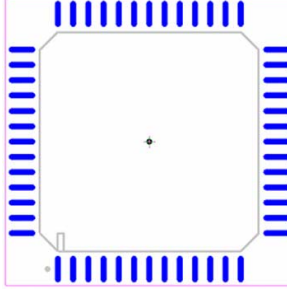
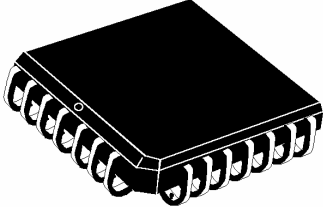
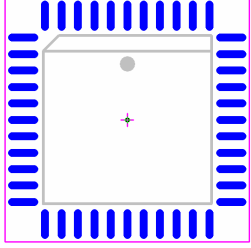
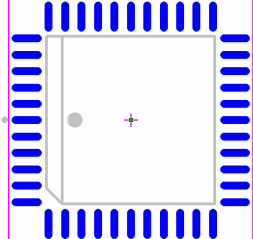
Table 7 – Resistor array and connector land pattern conventions

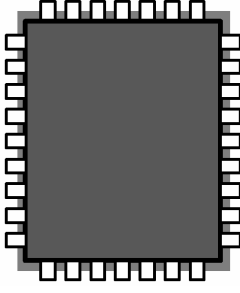
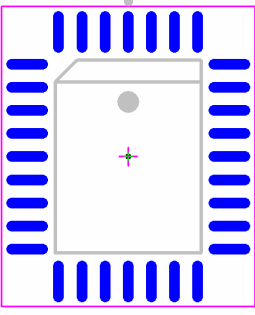
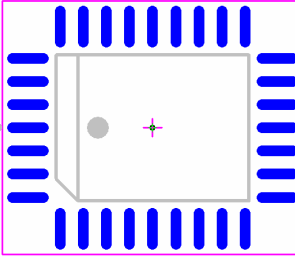
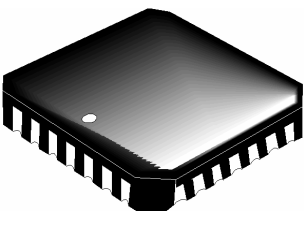
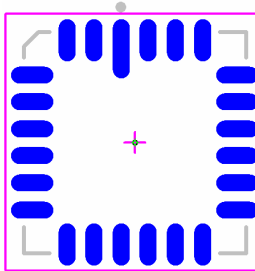
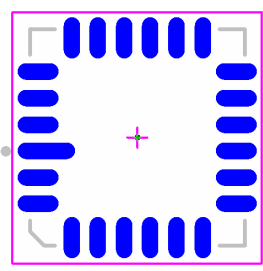
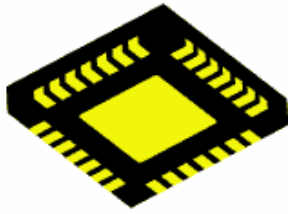
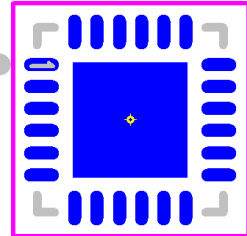
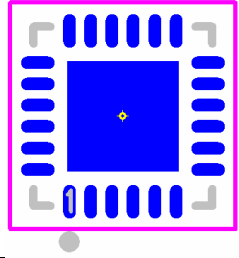
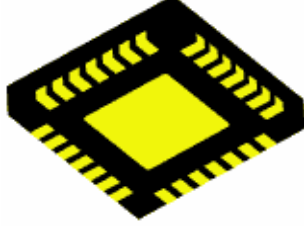
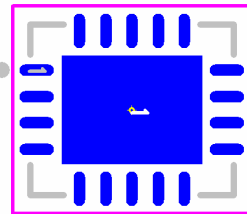
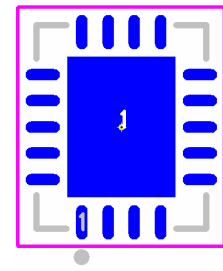

| Package type | Component example | Level A | Level B |
|----------------|---|---|---|
| Resistor array |  |  |  |
| SMT connector |  |  |  |

Table 8 provides a summary of the land pattern conventions for level A library concepts.

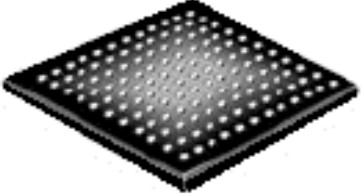
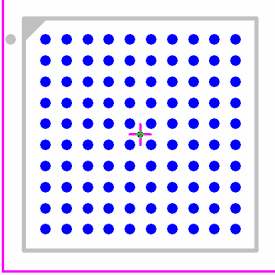
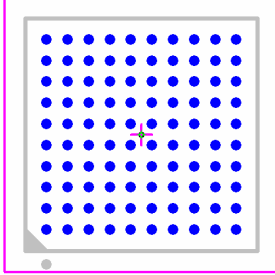
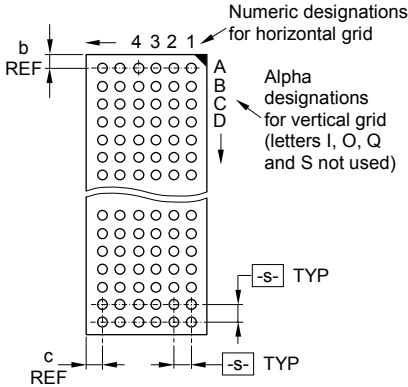
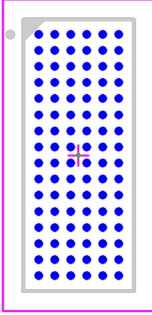
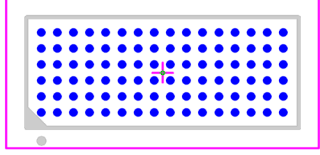
Table 8 – Level A land pattern convention summary

| Level A summary – Component marking identifies pin 1 of land pattern | |
|--|---|
| 1) | Chip capacitors, resistors and inductors (RES, CAP and IND) – Pin 1 of land pattern on left |
| 2) | Molded Inductors (INDM), resistors (RESM) and tantalum capacitors (CAPT) – Pin 1 of land pattern on left |
| 3) | Precision wire-wound Inductors (INDP) – Pin 1 of land pattern on left |
| 4) | MELF diodes – Pin 1 of land pattern on left |
| 5) | Aluminum electrolytic capacitors (CAPAE) – Pin 1 of land pattern on left |
| 6) | SOT Devices (SOT23, SOT23-5, SOT223, SOT89, SOT143, etc.) – Pin 1 of land pattern on upper left |
| 7) | TO252 & TO263 (DPAK Type) devices – Pin 1 of land pattern on upper left |
| 8) | Small outline gullwing ICs (SOIC, SOP, TSOP, SSOP, TSSOP) – Pin 1 of land pattern on upper left |
| 9) | Ceramic flat packs (CFP) – Pin 1 of land pattern on upper left |
| 10) | Small outline J lead ICs (SOJ) – Pin 1 of land pattern on upper left |
| 11) | Quad flat pack ICs (PQFP, SQFP) – Pin 1 of land pattern on upper left |
| 12) | Ceramic quad flat packs (CQFP) – Pin 1 of land pattern on upper left |
| 13) | Bumper quad flat pack ICs (BQFP Pin 1 center) – Pin 1 of land pattern on top center |
| 14) | Plastic leaded chip carriers (PLCC) – Pin 1 of land pattern on top center |
| 15) | Leadless chip carriers (LCC) – Pin 1 of land pattern on top center |
| 16) | Quad flat no-lead ICs (QFN) QFNS, QFN RV, QFN RH – Pin 1 of land pattern on upper left |
| 17) | Ball grid arrays (BGA) – Pin A1 of land pattern on upper left |
| 18) | Resistor array – Pin 1 of land pattern on upper left |
| 19) | SMT connector – Pin 1 of land pattern on upper left |

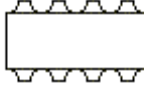
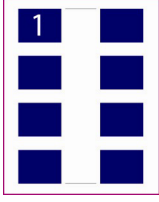
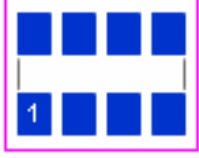
Table 9 provides a summary of the land pattern conventions for level B library concepts.

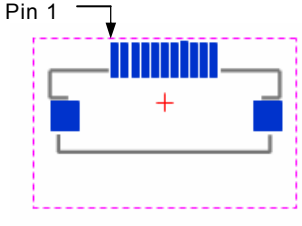
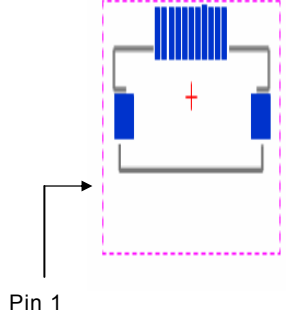
Table 9 – Level B land pattern convention summary

| Level B summary – Component marking identifies pin 1 of land pattern | |
|---|---|
| 1) | Chip capacitors, resistors and inductors (RES, CAP and IND) – Pin 1 of land pattern on left |
| 2) | Molded inductors (INDM), resistors (RESM) and tantalum capacitors (CAPT) – Pin 1 of land pattern on left |
| 3) | Precision wire-wound inductors (INDP) – Pin 1 of land pattern on left |
| 4) | MELF diodes – Pin 1 of land pattern on left |
| 5) | Aluminum electrolytic capacitors (CAPAE) – Pin 1 of land pattern on left |
| 6) | SOT devices (SOT23, SOT23-5, SOT223, SOT89, SOT143, etc.) – Pin 1 of land pattern on lower left |
| 7) | TO252 & TO263 (DPAK Type) devices – Pin 1 of land pattern on lower left |
| 8) | Small outline gullwing ICs (SOIC, SOP, TSOP, SSOP, TSSOP) – Pin 1 of land pattern on lower left |
| 9) | Ceramic flat packs (CFP) – Pin 1 of land pattern on lower left |
| 10) | Small outline J lead ICs (SOJ) – Pin 1 of land pattern on lower left |
| 11) | Quad flat pack ICs (PQFP, SQFP) – Pin 1 of land pattern on lower left |
| 12) | Ceramic quad flat packs (CQFP) – Pin 1 of land pattern on lower left |
| 13) | Bumper quad flat pack ICs (BQFP Pin 1 Center) – Pin 1 of land pattern on left center |
| 14) | Plastic leaded chip carriers (PLCC) – Pin 1 of land pattern on left center |
| 15) | Leadless chip carriers (LCC) – Pin 1 of land pattern on left center |
| 16) | Quad flat no-lead ICs (QFN) QFNS, QFN RV, QFN RH – Pin 1 of land pattern on left/lower left |
| 17) | Ball grid arrays (BGA) – Pin A1 of land pattern on lower left |
| 18) | Resistor array – Pin 1 of land pattern on lower left |
| 19) | SMT connector – Pin 1 of land pattern on lower left |

4 Origin point of land-pattern

4.1 General

Many variations can exist on the method used within CAD systems in order to develop a computer library for land patterns. In addition, component suppliers use many different delivery systems for providing the components to the machines used for insertion or attachment. Although an attempt is made in this standard to establish a set of rules that create library uniformity, it is important for every assembly company to evaluate the method and relationship between the component position by the CAD system and the component supplier's delivery orientation.

4.2 Surface mount components

In general, the point of origin is defined as the central position (centroid) of the circumscribing rectangle (courtyard) which is the most external rectangular surrounding the land pattern and component body description. A variation of the basic rules might be required for such components as connectors and components with moving parts. These shall meet the following conditions.

- a) In case of connectors with lock function, the point of origin is calculated on locked position.
- b) In case of components with moving part, the point of origin is calculated in the condition of delivery.

Figure 2 is an example of the point of origin of library symbols for connectors and moving part switches.

If a part has a lead that protrudes from component body and is not physically attached to the circuitry, it shall be included in the part outline even though that lead is not attached to the board surface.

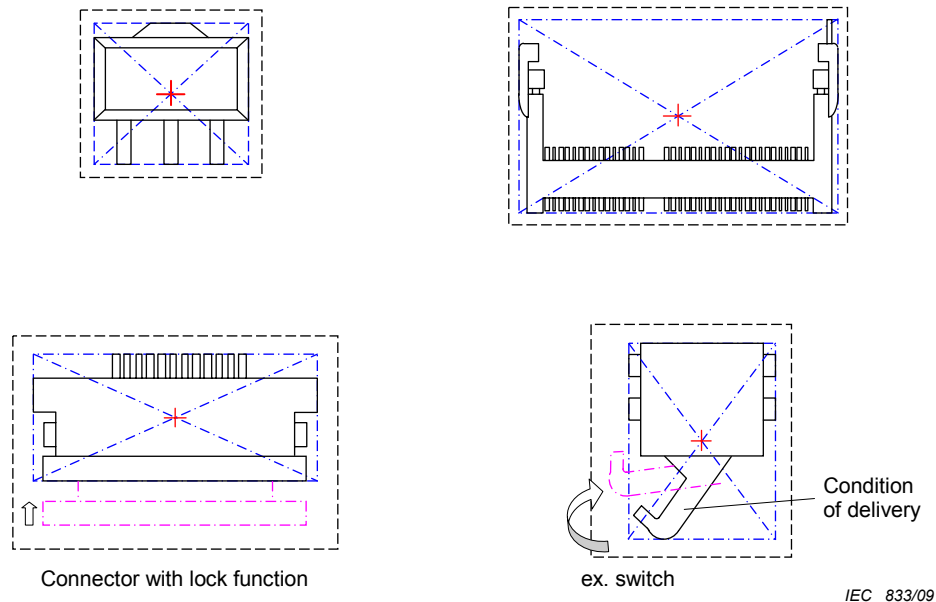
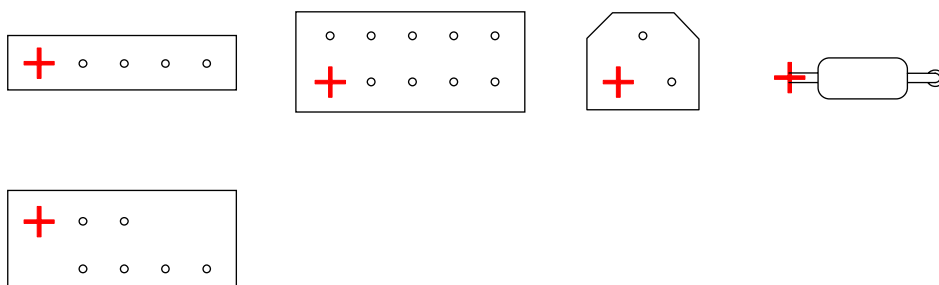

Figure 2 – Connector and switch library symbol examples

4.3 Through-hole leaded components

Through-hole components are identified in the CAD library looking down on the top of the component. The point of origin is defined as a terminal or the centroid. If the terminal is used as the point of origin it becomes the center of the left most terminal when the components are shown in a horizontal position. The point of origin is independent from the function of the terminal.

Figure 3 shows examples of components orientation using their terminals as the point of origin.



IEC 834/09

Figure 3 – Through-hole components with terminal point of origin orientation

If a part has a lead that protrudes from component body, but is not to be connected to the circuitry, it shall be included in the part outline even though that lead is not attached to a through-hole in the board.

5 Land pattern to foot print comparison

The land pattern, as viewed by the CAD system, represents the conductive pattern to which the component is attached. It is viewed from the primary side of the printed board, facing the designer. The primary side normally represents layer 1 of the component pattern for double-sided and multi-layer boards. The secondary side land patterns are viewed looking through the board. In order to have component orientation match the land pattern image, the library condition views the component facing toward the board surface of the primary side. Positioning a component on the secondary side requires taking the component in a mirror image condition and rotating it 180° to match the circuit configuration.

The definition of the total number of terminals is basically the number of contacts that the component makes with the interconnecting system. Leads are normally placed in holes with land patterns circumscribing the hole. Surface mount parts are normally attached to the surface mount land pattern of either the primary side or secondary side of the printed board.

6 Components with one terminal

6.1 Surface mount components

When components may be circular or square, the point of origin is the center of the terminal and their figures are shown in Figure 4. If there is an orientation to the one terminal component such as a tuning or adjustment feature, it shall be identified as the left hand side.

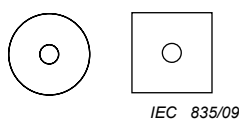

Figure 4 – Circular or square one terminal component

When component figures are oval or rectangular, and the terminal is in the center, they shall be represented in the CAD library in a horizontal condition. The center of the component is the point of origin as shown in Figure 5.

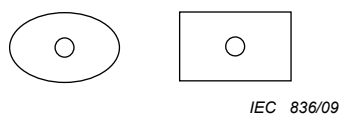

Figure 5 – Rectangular or oval one terminal component

When surface mount components have their single terminal not in the center, the component is described with the terminal on the upper left side. The point of origin is the center of the component. See Figure 6.

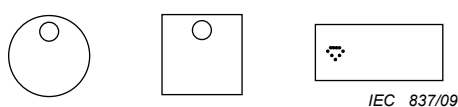

Figure 6 – Surface mount components with one lead offset

6.2 Through-hole leaded components

Through-hole leaded components shall be configured in the CAD library with their leads facing away from the component. The point of origin will be the single lead.

British Standards Institution (BSI)

BSI is the independent national body responsible for preparing British Standards. It presents the UK view on standards in Europe and at the international level.

It is incorporated by Royal Charter.

Revisions

British Standards are updated by amendment or revision. Users of British Standards should make sure that they possess the latest amendments or editions.

It is the constant aim of BSI to improve the quality of our products and services. We would be grateful if anyone finding an inaccuracy or ambiguity while using this British Standard would inform the Secretary of the technical committee responsible, the identity of which can be found on the inside front cover.

Tel: +44 (0)20 8996 9000 Fax: +44 (0)20 8996 7400

BSI offers members an individual updating service called PLUS which ensures that subscribers automatically receive the latest editions of standards.

Buying standards

Orders for all BSI, international and foreign standards publications should be addressed to BSI Customer Services.

Tel: +44 (0)20 8996 9001 Fax: +44 (0)20 8996 7001
Email: orders@bsigroup.com

You may also buy directly using a debit/credit card from the BSI Shop on the website www.bsigroup.com/shop

In response to orders for international standards, it is BSI policy to supply the BSI implementation of those that have been published as British Standards, unless otherwise requested.

Information on standards

BSI provides a wide range of information on national, European and international standards through its Library.

Various BSI electronic information services are also available which give details on all its products and services. Contact the Information Centre.

Tel: +44 (0)20 8996 7111

Fax: +44 (0)20 8996 7048 Email: info@bsigroup.com

Subscribing members of BSI are kept up to date with standards developments and receive substantial discounts on the purchase price of standards. For details of these and other benefits contact Membership Administration.

Tel: +44 (0)20 8996 7002 Fax: +44 (0)20 8996 7001

Email: membership@bsigroup.com

Information regarding online access to British Standards via British Standards Online can be found at www.bsigroup.com/BSOL

Further information about BSI is available on the BSI website at www.bsigroup.com

Copyright

Copyright subsists in all BSI publications. BSI also holds the copyright, in the UK, of the publications of the international standardization bodies. Except as permitted under the Copyright, Designs and Patents Act 1988 no extract may be reproduced, stored in a retrieval system or transmitted in any form or by any means – electronic, photocopying, recording or otherwise – without prior written permission from BSI.

This does not preclude the free use, in the course of implementing the standard of necessary details such as symbols, and size, type or grade designations. If these details are to be used for any other purpose than implementation then the prior written permission of BSI must be obtained. Details and advice can be obtained from the Copyright & Licensing Manager.

Tel: +44 (0)20 8996 7070 Email: copyright@bsigroup.com

BSI Group Headquarters

389 Chiswick High Road London W4 4AL UK

Tel +44 (0)20 8996 9001

Fax +44 (0)20 8996 7001

www.bsigroup.com/standards

raising standards worldwide™

BSI
British Standards