

BS EN 61184:2008



BSI British Standards

Bayonet lampholders

NO COPYING WITHOUT BSI PERMISSION EXCEPT AS PERMITTED BY COPYRIGHT LAW

raising standards worldwide™

BSI
British Standards

National foreword

This British Standard is the UK implementation of EN 61184:2008. It is identical to IEC 61184:2008. It supersedes BS EN 61184:1997 which is withdrawn.

The UK participation in its preparation was entrusted by Technical Committee CPL/34, Lamps and related equipment, to Subcommittee CPL/34/2, Lamp caps and holders.

A list of organizations represented on this committee can be obtained on request to its secretary.

This publication does not purport to include all the necessary provisions of a contract. Users are responsible for its correct application.

© BSI 2009

ISBN 978 0 580 59635 3

ICS 29.140.10

Compliance with a British Standard cannot confer immunity from legal obligations.

This British Standard was published under the authority of the Standards Policy and Strategy Committee on 31 March 2009

Amendments issued since publication

Amd. No.	Date	Text affected
-----------------	-------------	----------------------

English version

Bayonet lampholders
(IEC 61184:2008)

Douilles à baïonnette
(CEI 61184:2008)

Bajonett-Lampenfassungen
(IEC 61184:2008)

This European Standard was approved by CENELEC on 2008-08-01. CENELEC members are bound to comply with the CEN/CENELEC Internal Regulations which stipulate the conditions for giving this European Standard the status of a national standard without any alteration.

Up-to-date lists and bibliographical references concerning such national standards may be obtained on application to the Central Secretariat or to any CENELEC member.

This European Standard exists in three official versions (English, French, German). A version in any other language made by translation under the responsibility of a CENELEC member into its own language and notified to the Central Secretariat has the same status as the official versions.

CENELEC members are the national electrotechnical committees of Austria, Belgium, Bulgaria, Cyprus, the Czech Republic, Denmark, Estonia, Finland, France, Germany, Greece, Hungary, Iceland, Ireland, Italy, Latvia, Lithuania, Luxembourg, Malta, the Netherlands, Norway, Poland, Portugal, Romania, Slovakia, Slovenia, Spain, Sweden, Switzerland and the United Kingdom.

CENELEC

European Committee for Electrotechnical Standardization
Comité Européen de Normalisation Electrotechnique
Europäisches Komitee für Elektrotechnische Normung

Central Secretariat: rue de Stassart 35, B - 1050 Brussels

Foreword

The text of document 34B/1385/FDIS, future edition 3 of IEC 61184, prepared by SC 34B, Lamp caps and holders, of IEC TC 34, Lamps and related equipment, was submitted to the IEC-CENELEC parallel vote and was approved by CENELEC as EN 61184 on 2008-08-01.

This European Standard supersedes EN 61184:1997 + A1:2001 + A2:2004.

The significant technical changes with respect to EN 61184:1997 are as follows:

In EN 61184:2008, information to lampholders intended to be used in applications where they are accessible in normal use (class II as well as class I luminaires) are introduced. Additionally, in Table 11, lamp data where lamps no longer exist has been removed and requirements for shade holder rings have been amended to include shade rings according to EN 60399 into testing.

The following dates were fixed:

- latest date by which the EN has to be implemented at national level by publication of an identical national standard or by endorsement (dop) 2009-05-01
- latest date by which the national standards conflicting with the EN have to be withdrawn (dow) 2011-08-01

In this standard, the following print types are used:

- requirements proper: in roman type;
- *test specifications: in italic type;*
- notes: in small roman type.

Annex ZA has been added by CENELEC.

Endorsement notice

The text of the International Standard IEC 61184:2008 was approved by CENELEC as a European Standard without any modification.

In the official version, for Bibliography, the following notes have to be added for the standards indicated:

IEC 60061-4	NOTE	Harmonized as EN 60061-4:1992 (modified).
IEC 60238	NOTE	Harmonized as EN 60238:2004 (not modified).
IEC 61058-1	NOTE	Harmonized as EN 61058-1:2002 (modified).

Annex ZA (normative)

Normative references to international publications with their corresponding European publications

The following referenced documents are indispensable for the application of this document. For dated references, only the edition cited applies. For undated references, the latest edition of the referenced document (including any amendments) applies.

NOTE When an international publication has been modified by common modifications, indicated by (mod), the relevant EN/HD applies.

<u>Publication</u>	<u>Year</u>	<u>Title</u>	<u>EN/HD</u>	<u>Year</u>
IEC 60061 (mod)	Series	Lamp caps and holders together with gauges for the control of interchangeability and safety	EN 60061	Series
IEC 60061-1 (mod)	- ¹⁾	Lamp caps and holders together with gauges for the control of interchangeability and safety - Part 1: Lamp caps	EN 60061-1	1993 ²⁾
IEC 60061-2 (mod)	- ¹⁾	Lamp caps and holders together with gauges for the control of interchangeability and safety - Part 2: Lampholders	EN 60061-2	1993 ²⁾
IEC 60061-3 (mod)	- ¹⁾	Lamp caps and holders together with gauges for the control of interchangeability and safety - Part 3: Gauges	EN 60061-3	1993 ²⁾
IEC 60064 (mod)	- ¹⁾	Tungsten filament lamps for domestic and similar general lighting purposes - Performance requirements	EN 60064 + A11	1995 ²⁾ 2007
IEC 60068-2-75	1997	Environmental testing - Part 2-75: Tests - Test Eh: Hammer tests	EN 60068-2-75	1997
IEC 60112	2003	Method for the determination of the proof and the comparative tracking indices of solid insulating materials	EN 60112	2003
IEC 60227 (mod)	Series	Polyvinyl chloride insulated cables of rated voltages up to and including 450/750 V	- ³⁾	-
IEC 60245 (mod)	Series	Rubber insulated cables - Rated voltages up to and including 450/750 V	- ⁴⁾	-
IEC 60399	- ¹⁾	Barrel thread for lampholders with shade holder ring	EN 60399	2004 ²⁾
IEC 60417	Data base	Graphical symbols for use on equipment	-	-
IEC 60432 (mod)	Series	Incandescent lamps - Safety specifications	EN 60432	Series

¹⁾ Undated reference.

²⁾ Valid edition at date of issue.

³⁾ The HD 21 series, which is related to, but not directly equivalent with the IEC 60227 series, applies instead.

⁴⁾ The HD 22 series, *Cables of rated voltages up to and including 450/750 V and having cross-linked insulation*, which is related to, but not directly equivalent with the IEC 60245 series, applies instead.

<u>Publication</u>	<u>Year</u>	<u>Title</u>	<u>EN/HD</u>	<u>Year</u>
IEC 60529	1989	Degrees of protection provided by enclosures (IP Code)	EN 60529 + corr. May	1991 1993
IEC 60598-1 (mod)	- ¹⁾	Luminaires - Part 1: General requirements and tests	EN 60598-1	200X ⁵⁾
IEC 60664-1	2007	Insulation coordination for equipment within low-voltage systems - Part 1: Principles, requirements and tests	EN 60664-1	2007
IEC 60695-2-11	2000	Fire hazard testing - Part 2-11: Glowing/hot-wire based test methods - Glow-wire flammability test method for end-products	EN 60695-2-11	2001
IEC 60695-11-5	2004	Fire hazard testing - Part 11-5: Test flames - Needle-flame test method - Apparatus, confirmatory test arrangement and guidance	EN 60695-11-5	2005
ISO 4046-4	2002	Paper, board, pulps and related terms - Vocabulary - Part 4: Paper and board grades and converted products	-	-

⁵⁾ To be ratified.

CONTENTS

INTRODUCTION.....	6
1 General.....	7
1.1 Scope.....	7
1.2 Normative references.....	7
2 Terms and definitions.....	8
2.1 Materials.....	8
2.2 Means of fixing.....	8
3 General requirements.....	12
4 General conditions for tests.....	12
5 Standard ratings.....	13
5.1 Standard rated voltage.....	13
5.2 Standard rated currents.....	14
6 Classification.....	14
7 Marking.....	15
8 Dimensions.....	17
9 Protection against electric shock.....	18
10 Terminals.....	19
11 Provision for earthing.....	21
12 Construction.....	22
13 Switched lampholders.....	27
14 Moisture resistance, insulation resistance and electrical strength.....	28
15 Mechanical strength.....	30
16 Screws, current-carrying parts and connections.....	34
17 Creepage distances and clearances.....	34
18 General resistance to heat.....	35
19 Resistance to heat, fire and tracking.....	40
20 Resistance to excessive residual stresses (season cracking) and to rusting.....	42
Annex A (normative) Season cracking/corrosion test.....	60
Bibliography.....	62
Figure 1 – Loading device (see 15.1).....	44
Figure 2 – Bending apparatus (see 15.4).....	45
Figure 3 – Gauge for holes for backplate lampholders screws (see 12.11).....	46
Figure 4 – Clarification of some of the definitions in Clause 2.....	47
Figure 5 – Test cap B15d (see 18.3).....	48
Figure 6 – Test cap B22d (see 18.3).....	49
Figure 7 – Testing device (see 9.1).....	50
Figure 8 – Dimensions for shade support devices (see 8.1).....	51
Figure 9 – Dimensions for protective shields for B22d lampholders (see 9.1).....	52
Figure 10 – Test cap B15d (see 14.3).....	53

Figure 11 – Test cap B22d (see 14.3)	54
Figure 12 – Typical apparatus for the heating test (see 18.5).....	55
Figure 13 – Nipple thread for lampholders – Basic profile and design profile for the nut and for the screw	56
Figure 14 – Gauges for metric ISO thread for nipples	57
Figure 15 – Impact-test apparatus	58
Figure 16 – Mounting support	58
Figure 17 – Ball-pressure test apparatus	59
Figure 18 – Pressure apparatus	59
Table 1 – Dimensions of threaded entries and set screws	18
Table 2 – Minimum dimensions of pillar type terminals.....	20
Table 3 – Limits for contact forces	23
Table 4 – Pull and torque values.....	26
Table 5 – Heights of fall	32
Table 6 – Maximum deformation values	33
Table 7 – Torque values	34
Table 8 – Minimum distances for a.c. (50/60 Hz) sinusoidal voltages – Impulse withstand category II.....	35
Table 9 – Heating cabinet temperature	36
Table 10 – Heating cabinet temperature	37
Table 11 – Test temperature and test lamp data	39
Table A.1 – Ph adjustment.....	60

INTRODUCTION

This standard covers safety requirements for bayonet lampholders and includes references to IEC 60061 for the control of interchangeability and safety of the cap and holder fit.

NOTE Safety requirements ensure that electrical equipment constructed in accordance with these requirements does not endanger the safety of persons, domestic animals or property when properly installed and maintained and used in applications for which it was intended.

The thermal characteristics of lampholders are specified by the rated operating temperature (symbol T), which is the highest temperature for which the lampholder is designed. The temperature rating and the resistance to heat specified in this standard are based on two different principles, as presently found in IEC 60238 for Edison screw lampholders and in other national standards for bayonet lampholders. After experience, it may be possible to rationalize the systems in future editions of this standard.

BAYONET LAMPHOLDERS

1 General

1.1 Scope

This International Standard applies to bayonet lampholders B15d and B22d for connection of lamps and semi-luminaires to a supply voltage of 250 V.

This standard also covers lampholders which are integral with a luminaire or intended to be built into appliances. It covers the requirements for the lampholder only.

For all other requirements, such as protection against electric shock in the area of the terminals, the requirements of the relevant appliance standard shall be observed and tested after building into the appropriate equipment, when that equipment is tested according to its own standard. Lampholders for use by luminaire manufacturers only are not for retail sale.

NOTE Where lampholders are used in luminaires, their maximum operating temperatures are specified in IEC 60598-1.

B15 denotes the cap/holder fit as defined by IEC 60061-1, sheet 7004-11 and IEC 60061-2, sheet 7005-16 with the corresponding gauges.

B22 denotes the cap/holder fit as defined by IEC 60061-1, sheet 7004-10 and IEC 60061-2, sheet 7005-10 with the corresponding gauges.

1.2 Normative references

The following referenced documents are indispensable for the application of this document. For dated references, only the edition cited applies. For undated references, the latest edition of the referenced document (including any amendments) applies.

IEC 60061 (all parts), *Lamp caps and holders together with gauges for the control of interchangeability and safety*

IEC 60061-1, *Lamp caps and holders together with gauges for the control of interchangeability and safety – Part 1: Lamp caps*

IEC 60061-2, *Lamp caps and holders together with gauges for the control of interchangeability and safety – Part 2: Lampholders*

IEC 60061-3, *Lamp caps and holders together with gauges for the control of interchangeability and safety – Part 3: Gauges*

IEC 60064, *Tungsten filament lamps for domestic and similar general lighting purposes – Performance requirements*

IEC 60068-2-75:1997, *Environmental testing – Part 2-75: Tests – Test Eh: Hammer tests*

IEC 60112:2003, *Method for the determination of the proof and the comparative tracking indices of solid insulating materials*

IEC 60227 (all parts), *Polyvinyl chloride insulated cables of rated voltages up to and including 450/750 V*

IEC 60245 (all parts), *Rubber insulated cables – Rated voltages up to and including 450/750 V*

IEC 60399, *Barrel thread for lampholders with shade holder ring*

IEC 60417, *Graphical symbols for use on equipment*

IEC 60432 (all parts), *Incandescent lamps – Safety specifications*

IEC 60529:1989, *Degrees of protection provided by enclosures (IP Code)*

IEC 60598-1, *Luminaires – Part 1: General requirements and tests*

IEC 60664-1:2007, *Insulation coordination for equipment within low-voltage systems – Part 1: Principles, requirements and tests*

IEC 60695-2-11:2000, *Fire hazard testing – Part 2-11: Glowing/hot-wire based test methods – Glow-wire flammability test method for end-products*

IEC 60695-11-5:2004, *Fire hazard testing – Part 11-5: Test flames – Needle-flame test method – Apparatus, confirmatory test arrangement and guidance*

ISO 4046-4:2002, *Paper, board, pulps and related terms – Vocabulary – Part 4: Paper and board grades and converted products*

2 Terms and definitions

For the purposes of this document, the following terms and definitions apply.

NOTE For clarification of some definitions, see also Figure 4.

2.1 Materials

2.1.1

plastic lampholder

lampholder, the exterior of which is made wholly of plastic material

NOTE The exterior is any part of the lampholder which, when wired and fully assembled and fitted with the testing device shown in Figure 7, can be touched directly by the standard test finger of IEC 60529.

2.1.2

ceramic lampholder

lampholder, the exterior of which is made wholly of ceramic material (see note to 2.1.1)

2.1.3

metal lampholder

lampholder, the exterior of which is made wholly or partly of metal (see note to 2.1.1)

2.2 Means of fixing

2.2.1

cord grip lampholder

lampholder incorporating a method of retaining a flexible cord by which it may be suspended (see Figure 4a)

2.2.2

threaded entry lampholder

lampholder incorporating a threaded component at the point of entry of the supply wires permitting the lampholder to be mounted on a mating threaded support (formerly called nipple lampholder) (see Figure 4b)

2.2.3

backplate lampholder

lampholder so designed as to be suitable for mounting, by means of an associated or integral backplate, directly on to a supporting surface or appropriate box (see Figure 4c)

2.3

terminal/contact assembly

part or assembly of parts which provides a means of connection between the termination of a supply conductor and the contact-making surfaces of the corresponding lamp cap as well as resilient means to maintain contact pressure

- a) rising type, where the terminal is allowed to rise parallel with the lamp axis on insertion of a lamp cap;
- b) non-rising type, where the terminal is not allowed to rise on insertion of a lamp cap

NOTE The terminal and the barrel may be a unique element.

2.4

union ring

cylindrical component which joins together separate external parts of the lampholder

2.5

shade ring

cylindrical component having an internal thread or other means to engage a corresponding support on the outer shell and intended to carry or retain a shade

2.6

skirt (plastic lampholders only)

component similar to a shade ring but having a longer cylindrical form to extend to the full length of the lampholder body

2.6.1

protective shield (plastic lampholders only)

component similar to a skirt but having a flared open end to protect the user from accidental contact with the lamp cap (see Figure 9)

2.7

dome

part of a cord grip lampholder or threaded entry lampholder which shields the connecting terminals

2.8

barrel

part of a lampholder which serves for mechanical connection of the lamp cap with the lampholder

2.9

lampholder for building-in

lampholder designed to be built into a luminaire, an additional enclosure or the like

2.9.1**unenclosed lampholder**

lampholder for building-in so designed that it requires additional means, for example enclosures, to meet the requirements of this standard with regard to protection against electric shock

2.9.2**enclosed lampholder**

lampholder for building-in so designed that, on its own, it fulfils the requirements of this standard with regard to protection against electric shock and, if appropriate, IP classification

2.10**independent lampholder**

lampholder so designed that it can be mounted separately from a luminaire and at the same time provide all the necessary protection according to its classification and marking

2.11**switched lampholder**

lampholder provided with an integral switch to control the supply to the lamp

2.12**basic insulation**

insulation applied to live parts to provide basic protection against electric shock

NOTE Basic insulation does not necessarily include insulation used exclusively for functional purposes.

2.13**supplementary insulation**

independent insulation applied in addition to basic insulation in order to provide protection against electric shock in the event of a failure of basic insulation

2.14**double insulation**

insulation comprising both basic insulation and supplementary insulation

2.15**reinforced insulation**

single insulation system applied to live parts which provides a degree of protection against electric shock equivalent to double insulation under the conditions specified

NOTE The term "insulation system" does not imply that the insulation must be one homogeneous piece. It may comprise several layers which cannot be tested singly as supplementary or basic insulation.

2.16**live part**

conductive part which may cause an electric shock in normal use

The neutral conductor is, however, regarded as a live part.

The test to determine whether or not a conductive part is a live part which may cause an electric shock is given in Annex A of IEC 60598-1.

2.17

type test

test or series of tests made on a type test specimen for the purpose of checking compliance of the design of a given product with the requirements of the relevant standard

2.18

type test sample

sample consisting of one or more similar specimens submitted by the manufacturer or responsible vendor for the purpose of a type test

2.19

semi-luminaire

unit similar to a self-ballasted lamp but designed to utilize a replaceable light source and/or starting device

2.20

rated operating temperature

highest temperature for which the lampholder is designed

2.21

rated pulse voltage

highest peak of pulse voltages that the holder is able to withstand

2.22

impulse withstand category

numeral defining a transient overvoltage condition

NOTE Impulse withstand categories I, II, III and IV are used.

a) Purpose of classification of impulse withstand categories

Impulse withstand categories are to distinguish different degrees of availability of equipment with regard to required expectations on continuity of service and on an acceptable risk of failure.

By selection of impulse withstand levels of equipment, insulation co-ordination can be achieved in the whole installation reducing the risk of failure to an acceptable level providing a basis for overvoltage control.

A higher characteristic numeral of an impulse withstand category indicates a higher specific impulse withstand of the equipment and offers a wider choice of methods for overvoltage control.

The concept of impulse withstand categories is used for equipment energized directly from the mains.

b) Description of impulse withstand categories

Equipment of impulse withstand category I is equipment which is intended to be connected to the fixed electrical installations of buildings. Protective means are taken outside the equipment - either in the fixed installation or between the fixed installation and the equipment - to limit transient overvoltages to the specific level.

Equipment of impulse withstand category II is equipment to be connected to the fixed electrical installations of buildings.

Equipment of impulse withstand category III is equipment which is part of the fixed electrical installations and other equipment where a higher degree of availability is expected.

Equipment of impulse withstand category IV is for use at or in the proximity of the origin of the electrical installations of buildings upstream of the main distribution board.

2.23

primary circuit

circuit which is directly connected to the AC mains supply

It includes, for example, the means for connection to the AC mains supply, the primary windings of transformers, motors and other loading devices.

2.24

secondary circuit

circuit which has no direct connection to a primary circuit and derives its power from a transformer, converter or equivalent isolation device, or from a battery

Exception: autotransformers. Although having direct connection to a primary circuit, the tapped part of them is also deemed to be a secondary circuit in the above sense.

NOTE Mains transients in such a circuit are attenuated by the corresponding primary windings. Also inductive ballasts reduce the mains transient voltage height. Therefore, components located after a primary circuit or after an inductive ballast can be suited for an impulse withstand category of one step lower, i.e. for impulse withstand category II.

3 General requirements

Lampholders shall be so designed and constructed that in normal use they function reliably and cause no danger to persons or surroundings.

In general, compliance is checked by carrying out all the relevant tests specified.

Independent lampholders, not specifically intended for building-in, shall comply with the requirements of the following sections and subclauses of IEC 60598-1 where the subject-matter of these headings is not dealt with in the present standard.

- | | |
|--------------------------|--|
| Section 2 | – Classification |
| Section 3 | – Marking |
| Section 4 | – Construction (as appropriate) |
| Section 8 | – Protection against electric shock |
| Section 9 | – Resistance to dust, solid objects and moisture |
| Section 10 | – Insulation resistance and electric strength (for class II) |
| Subclauses 12.4 and 12.5 | – Thermal tests |

4 General conditions for tests

4.1 Tests according to this standard are type tests.

NOTE The requirements and tolerances permitted by this standard are related to testing of a type test sample submitted for that purpose. Compliance of the type test sample does not ensure compliance of the whole production of a manufacturer with this safety standard. In addition to type testing, conformity of production is the responsibility of the manufacturer and may include routine tests and quality control.

For further information see IEC 60061-4, sheet 7007-13.

4.2 Unless otherwise specified, the samples are tested as delivered and installed as in normal use without lamps, at an ambient temperature of $20\text{ °C} \pm 5\text{ °C}$.

4.3 All inspections and tests are carried out on a total of:

- 8 specimens for unswitched lampholders, or
- 11 specimens for switched lampholders;

in the order of the clauses as follows:

- 3 specimens: Clauses 3 to 12;
- 3 specimens: Clauses 14 to 18;
- 3 specimens: Clause 13 (switched lampholder tests only);
- 2 specimens: Clauses 19 and 20.

NOTE For testing of screwless terminals according to 10.2, separate additional specimens are required.

This is also necessary for independent lampholders not specifically intended for building-in (see Clause 3).

4.4 If no lampholder fails in the complete series of tests specified in 4.3, then lampholders of that type shall be deemed to comply with this standard.

If one lampholder fails in any group in the complete series of tests specified in 4.3, the lampholders of that type shall be deemed to have failed to comply with this standard, unless that lampholder can be shown to be not representative of normal production or design, in which case a further set of lampholders shall be submitted to the test or tests in that group. Generally, it will be necessary to only repeat the test in which failure occurs. However, if the lampholder fails in the test specified in Clauses 14 to 18 inclusive, the tests shall be repeated from the tests of Clause 14 onwards.

An additional type test sample may be submitted, together with the first type test sample, in case one lampholder fails, in which case the additional type test sample shall then be tested and shall only be rejected if a further failure occurs. If there is no failure in this retest, then lampholders of that type shall be deemed to comply with this standard. If the additional type test sample is not submitted at the same time, a failure of one lampholder shall entail a rejection.

If more than one specimen fails in the complete series of tests specified in 4.3 then lampholders of that type shall be deemed to have failed to comply with this standard.

NOTE In view of the duration of the test procedure, lampholders differing only in detail and having the same constructional principles and materials may be covered by a single series of type tests, subject to agreement between applicant and test house.

5 Standard ratings

5.1 Standard rated voltage

For all lampholders only a rated voltage of 250 V is allowed.

Lampholders B15d are not intended for use in circuits with ignitors.

Lampholders B22d shall not be used in circuits with ignitors without approval from the lampholder manufacturer.

NOTE From the theoretical point of view, the minimum creepage distance required for a holder B22d will result in a clearance sufficient to withstand a pulse voltage of 2,5 kV.

The measures required to allow easy contact travel and lamp removal might in some situations, however, be accompanied by unforeseen reduction of the clearance without

influence on normal operation (without ignition) where only the creepage distances are critical.

BY22d lampholders are specially designed for use in ignitor circuits.

5.2 Standard rated currents

Standard rated currents are:

- 2 A for lampholders B15;
- 2 A for lampholders B22.

The rated current shall be not less than the standard value. Rated currents higher than 2 A are allowed.

Compliance with the requirements of 5.1 and 5.2 is checked by inspection of the marking.

6 Classification

Lampholders are classified:

6.1 According to the material of the exterior:

- lampholders whose exterior is made wholly of plastic material;
- lampholders whose exterior is made wholly of ceramic material;
- lampholders whose exterior is made wholly or partly of metal.

NOTE For definition of "exterior", see note to 2.1.1.

Lampholders with external parts consisting partly of metal and lampholders comprising external parts of insulating material with a conductive outer surface, e.g. a metallized outer shell, are considered as metal lampholders.

This does not apply to threaded entries and external parts, as for example a metal shade ring mounted on to the outside of a lampholder of insulating material, which cannot become live even in the case of an insulation fault. Metal lampholders with insulating coverings are considered as metal lampholders.

If in doubt as to whether or not a surface is conductive, two stripe-electrodes 1,5 mm wide, 25 mm long and with a distance of 2 mm from each other are applied to the surface (e.g. with silver conductive paint). In accordance with 14.3, the insulating resistance is measured between the stripes. The surface is considered to be conductive if the resistance is less than 5 M Ω .

6.2 According to degree of protection against solid objects and ingress of water:

- ordinary lampholders;
- drip-proof lampholders.

NOTE A classification for higher degrees of protection against ingress of water is under consideration.

6.3 According to method of fixing:

- threaded entry lampholders;
- cord grip lampholders;
- backplate lampholders;
- other lampholders.

NOTE Examples of other lampholders are lampholders provided with a mechanical suspension device e.g. a hook.

6.4 According to type:

- switched lampholders provided with an integral switch to control the supply to the lamp;
- non-switched lampholders.

6.5 According to protection against electric shock:

- enclosed lampholders;
- unenclosed lampholders;
- independent lampholders.

6.6 According to resistance to heat:

- without T marking, suitable for rated operating temperatures up to and including 135 °C for B15d lampholders and 165 °C for B22d lampholders;
- with Txxx marking, suitable for rated operating temperatures up to and including the temperature marked or declared by the manufacturer. These temperatures shall be not lower than 140 °C for B15d lampholders and not lower than 170 °C for B22d lampholders;

NOTE The value of the temperature marking is increased by steps of 10 °C.

- with T1 marking, suitable for temperatures on the lamp cap up to and including 165 °C;

NOTE The continued use of T1 lampholders is subject to review.

- with T2 marking, suitable for temperatures on the lamp cap up to and including 210 °C.

7 Marking

7.1 Lampholders shall be marked with:

- rated voltage, in volts;
- rated operating temperature Txxx, T1 or T2, if applicable (see 6.6).
In the first version, the letter T shall be followed by the value of the rated operating temperature in degrees Celsius;
- symbol for nature of supply, if required (for switched lampholders only);
- for lampholders whose exterior is made wholly of ceramic material, information on the rated operating temperature, if applicable, shall either be marked on the lampholder or given in the manufacturer's catalogue;
- mark of origin (this may take the form of a trade mark, or the manufacturer's or responsible vendor's name or identification mark);

NOTE The mark of origin is not intended to mean the country of origin.

- either a unique catalogue number or an identifying reference;

NOTE An identifying reference may include numbers, letters, colour, etc. to identify the lampholder by reference to the manufacturer's or responsible vendor's catalogue or similar literature.

- rated current, in amperes, if greater than 2 A;
- IP number, if other than ordinary, for degree of protection against ingress of water (see 6.2);
- for single-pole switched lampholder, the switched pole shall be identified.

For lampholders according to this standard, the distances for impulse withstand category II are applicable. This information shall be indicated in the manufacturer's catalogue or the like.

Lampholders complying with the electrical strength test for double or reinforced insulation and having creepage distances and clearances equivalent to double or reinforced insulation offer an adequate level of protection for use in luminaires where they are accessible in normal use.

Such lampholders are addressed as lampholders for use in class II applications. This information shall be indicated in the manufacturer's catalogue or the like.

NOTE Values for creepage distances and clearances as well as test voltages for the electrical strength test for double or reinforced insulation are given in IEC 60598-1.

To achieve sufficient creepage distances and clearances to outer accessible surfaces, additional attachments could be used. In some cases, these dimensions might be achieved only after mounting the lampholder in the luminaire. Relevant information should be provided in the manufacturer's catalogue or the like.

7.2 If symbols are used for current and voltage, A shall denote amperes and V volts.

Alternatively, figures alone may be used, the figure for the rated current being marked before or above that for the rated voltage and separated from the latter by a line.

Therefore, the marking for current and voltage may be as follows:

$$4 \text{ A } 250 \text{ V or } 4/250 \text{ or } \frac{4}{250}$$

The symbol for d.c. shall be $\overline{\text{---}}$ (see IEC 60417, symbol IEC 60417-5031(2002-10)).

The symbol for protection against ingress of water shall, for drip-proof lampholders, be IPX1.

NOTE Where X is used in an IP number, it is intended to indicate a missing numeral in the symbol but both the appropriate numerals in accordance with IEC 60529 must be marked on the lampholder.

7.3 The marking of degree of protection against ingress of water shall be on the outside of the lampholder.

7.4 An earthing terminal shall be indicated by the symbol  (see IEC 60417, symbol IEC 60417-5019 (2006-08)).

This symbol shall not be placed on screws, removable washers or other easily removable parts.

Compliance is checked by inspection.

NOTE In the United Kingdom, metal lampholders intended for retail sale must have the following warning notice attached or incorporated in the associated packaging:

"THIS LAMPHOLDER MUST BE EARTHED".

7.5 Where the terminal size specified in 10.2 is not complied with, the relevant value, or values in case of a range, shall be shown in mm² followed by a small square (for example 0,5 □)

For unenclosed lampholders such marking is not required but relevant information shall be given in the manufacturer's mounting instructions.

7.6 Marking shall be durable and easily legible.

Compliance with the requirements of 7.1 to 7.5 shall be checked by inspection, and by trying to remove the marking by rubbing lightly for 15 s with a piece of cloth soaked with water and for a further 15 s with a piece of cloth soaked with petroleum spirit. After the tests, the marking shall be still legible.

NOTE The petroleum spirit used should consist of a solvent hexane with a content of aromatics of maximum 0,1 volume percentage, a kauri-butanol value of 29, an initial boiling-point of approximately 65 °C, a dry-point of approximately 69 °C and a specific density of approximately 0,68 g/cm³.

7.7 In the United Kingdom a threaded entry lampholder without means for restraining the flexible cord, intended for retail sale, shall have the following warning notice attached or incorporated in the associated packaging:

"Do not connect this lampholder to a flexible cord which may be subject to tension in normal use, unless means are provided to relieve the conductors from strain and to protect the insulation".

8 Dimensions

8.1 Lampholder dimensions shall comply with the current edition of the standard sheets of IEC 60061.

Compliance is checked by measuring in conformity with standard sheets 7005-10 and 7005-16 of IEC 60061-2 and by application of the specified gauges according to the current edition of IEC 60061-3.

Lampholders designed with a barrel thread for shade holder rings and shade holder rings shall comply with IEC 60399 where applicable and with the dimensional requirements of Figure 8.

Compliance is checked by measurement and by means of the gauges given in IEC 60399.

8.2 The threaded entries of lampholders shall be provided with one of the following screw threads in accordance with Figure 13.

- lampholders B15: M10×1;
- lampholders B22: M10×1 or M13×1.

NOTE 1

- The threaded entry M10×1 is mainly intended for the internal wiring of luminaires.
- In the United Kingdom, threaded entry lampholders with 3/8 inch × 26 TPI and 1/2 inch × 26 TPI screw threads are permitted for retail sale.
- In France, threaded entry lampholders with 11 mm × 19 TPI and 17 mm × 19 TPI screw threads are permitted for replacement.

Compliance is checked by means of the gauges in accordance with Figure 14. In case of doubt, the gauge is introduced into the entry by applying a torque of 0,5 Nm.

NOTE 2 Other thread sizes are permissible for lampholders not intended for retail sale.

8.3 The dimensions of threaded entries and set screws, if any, shall not be less than the values shown in Table 1.

Table 1 – Dimensions of threaded entries and set screws

Nominal thread diameter	M13×1 M10×1 mm
Length of threaded entry	
– metal entry	3,0
– entry of insulating material	5,0
Diameter of set screw (if any)	
– screw with head	2,5
– screw without head	3,0

A negative deviation of 0,15 mm from the nominal value for thread diameter is allowed.

Compliance is checked by measurement.

NOTE If it is necessary to take the lampholder apart in order to check compliance with the requirements of 8.2 to 8.3, such checking is done after the tests of Clause 12.

9 Protection against electric shock

9.1 Lampholders shall be so designed that, when fully assembled, live parts of the lampholder are not accessible when the lampholder is fitted with the testing device shown in Figure 7.

NOTE The use of a skirt or protective shield (see 2.6 and 2.6.1) is optional. An example of a protective shield is shown in Figure 9.

For independent and enclosed lampholders compliance shall be checked by the application of the standard test finger in accordance with IEC 60529.

This test finger is applied in every possible position with a force not exceeding 10 N, an electrical indicator being used to show contact with live parts. It is recommended that a voltage of not less than 40 V is used.

Independent lampholders and enclosed lampholders are mounted as in normal use, e.g. on a threaded support or on a supporting surface or the like.

Unenclosed lampholders are tested only after appropriate installation in a luminaire or other additional enclosure. For these reasons, such lampholders are not for retail sale.

9.2 The construction shall be such that no metal parts of the lampholder other than the terminals and contact mechanism shall become live in normal service either before, during or after insertion of the lamp.

Compliance is checked by inspection.

9.3 Parts providing protection against accidental contact with live parts shall, when correctly assembled, have sufficient mechanical strength to withstand such forces as may arise during normal removal and replacement as may be necessary to fit supply cords or cables.

They shall also withstand the normal stresses arising from the fitting of corresponding normal lamps and appropriate lamp shades.

It shall be possible to remove and replace, using a reasonable degree of force corresponding to normal use, a corresponding normal lamp and shade, or similar device if fitted, without removing those parts providing protection against accidental contact with live parts.

Compliance is checked by inspection and by the tests of 15.3 which shall be repeated following the test of 18.1.

9.4 External parts of drip-proof lampholders shall be of insulating material, with the exception of threaded entries and shade carrier rings, which cannot become live in the event of a fault.

Lacquer or enamel is not deemed to provide adequate protection for the purpose of this clause.

Compliance is checked by inspection.

NOTE Parts which are separated from live parts by double or by reinforced insulation are considered as parts which cannot become live in the event of a fault.

10 Terminals

10.1 Lampholders shall be provided with at least one of the following means of connection:

- screw-type terminals;
- screwless terminals;
- tabs or pins for push-on connections;
- posts for wire wrapping;
- soldering lugs;
- connecting leads (non-rewirable tails).

Compliance is checked by inspection.

10.2 Terminals shall permit the connection of conductors having the following nominal cross-sectional areas unless otherwise specified in the manufacturer's mounting instructions or marked on the lampholder (see 7.5):

- 0,5 mm² to 1,0 mm², for lampholders B15d and B22d with M10×1 threaded entry and those with cord grip;

NOTE In the United Kingdom, this requirement is amended to read:

"0,5 mm² to 0,75 mm² for 2 and 3 core PVC insulated sheathed flexible cord for use with lampholders B15d and B22d with a cord grip, or 0,5 mm² to 1,0 mm² for single insulated conductors for use with B15d and B22d lampholders with M10×1 threaded entry".

- 0,5 mm² to 2,5 mm² for other B22d lampholders.

Compliance is checked by inspection, by fitting conductors of the smallest and largest cross-sectional area specified and by the tests of Clause 16.

For cord grip lampholders, lampholders B15d and B22d with M10×1 threaded entry, flexible conductors are used. In all other cases, the conductors are of the solid type. Threaded entry lampholders are tested on a screwed conduit.

10.3 Terminals shall be of the screw type or the method of connection shall be at least equivalent.

Screw-type terminals shall have an ISO (metric) thread or a thread comparable in pitch and mechanical strength, and shall otherwise comply with Section 14 of IEC 60598-1.

Terminals of the pillar type shall have dimensions not less than those shown in Table 2.

Table 2 – Minimum dimensions of pillar type terminals

Lampholder	Minimum nominal thread diameter	Minimum diameter conductor hole
	mm	mm
B22	2,5	2,5
B15	2,5	2,5 a
^a The diameter of the hole shall be not more than 0,6 mm larger than the diameter of the screw.		

The length of the threaded part of the terminal screw shall be not less than the sum of the diameter of the hole for the conductor and the length of thread in the pillar.

NOTE In order to minimize damage to the conductor, the screw should have a slightly rounded end, and the wall of the hole (against which the screw clamps the conductor) should be unbroken.

Screwless terminals shall be considered equivalent to screw-type terminals when complying with Section 15 of IEC 60598-1. Lampholders, unless intended for sale to luminaire or other equipment manufacturers, shall be provided with terminals which will be equally satisfactory with both rigid (solid or stranded) conductors and flexible cables or cords.

Compliance is checked by inspection and measurement.

10.4 Terminals shall be so located that, after correct fitting of the wires, there is no risk of accidental contact between live parts and accessible metal parts, or moving parts of a switch, before, during and after operation.

Compliance is checked by inspection and by the following test:

The insulation is removed over a length of 4 mm from the end of a flexible conductor having the minimum nominal cross-sectional area specified in 10.2. One wire of the stranded conductor is left free and the remainder are fully inserted into and clamped in the terminal of the lampholder mounted and installed as in normal use (locking screws tightened, etc.).

The free wire is bent, without tearing the insulation back, in every possible direction, but without making sharp bends around barriers.

The free wire of a conductor connected to a live terminal shall not touch any metal part which is accessible, or moving parts of a switch, and that of a conductor connected to an earthing terminal shall not touch any live part.

If necessary, the test is repeated with the free wire in another position.

NOTE The prohibition against making sharp bends around barriers does not imply that the free wire shall be kept straight during the test. Sharp bends are, moreover, made if it is considered likely that such bends can occur during the normal assembly of the lampholder.

10.5 The requirements of 10.3 do not apply to lampholders intended to be factory-mounted in luminaires and which are provided with connecting leads (non-rewirable tails), tab-terminals or equally effective means.

Connecting leads (non-rewirable tails) shall be connected to the lampholders by soldering, welding, crimping or by any other equivalent method.

Leads shall consist of insulated conductors.

The insulation of the leads shall be at least equal in mechanical and electrical properties to those specified in IEC 60227 or IEC 60245 or comply with the relevant requirements of 5.3 in IEC 60598-1.

Insulation of the free end of the leads may be stripped.

Fixing of the leads to the lampholders shall withstand the mechanical forces that may occur in normal use.

Compliance is checked by inspection and by the following test, which is made after the test of 19.2 on the same three specimens.

Each connecting lead is subjected to a pull of 20 N, applied without jerks for 1 min in the most unfavourable direction.

During the test, the leads shall not move from their fixing.

After the test, the lampholders shall show no damage within the meaning of this standard.

11 Provision for earthing

11.1 If provision is required for earthing a lampholder, the means adopted shall not interfere with clearance or creepage distance or with the normal functioning of the lampholder. For metal lampholders, the earth terminal or other means of earthing shall be in effective electrical contact with all exposed non-current-carrying metal parts.

Metal parts of the cord anchorage, including clamping screws, shall be insulated from the earthing circuit.

Compliance is checked by inspection.

11.2 Earthing terminals shall comply with the requirements of Clause 10.

Their clamping means shall be such that it shall not be possible to loosen screw terminals without the use of a tool or screwless terminals unintentionally by hand.

Compliance is checked by inspection and by the tests of Clause 10.

NOTE In general, the designs commonly used for current-carrying terminals (complying with the requirements of this standard) provide sufficient resilience to comply with the latter requirement; for other designs, special provisions, such as the use of an adequate resilient part which is not likely to be removed inadvertently, may be necessary.

11.3 Metal lampholders intended to be earthed shall be so designed that all accessible external metal parts can be connected electrically to earth, the method of connection depending upon the intended method of installation of the lampholder.

This requirement may be met by the use of an earthing terminal or other particular provision for the connection of an independent earth continuity conductor. This does, however, not preclude the use of other means by earthing continuity, such as the nipple, the backplate, the shade ring or other means for attaching the lampholder to earthed parts of the luminaire.

NOTE Lampholders intended to be earthed but not provided with an earthing terminal or with connecting leads are not for retail sale.

Accessible metal parts of lampholders without earthing terminal which may become live in the event of an insulation fault shall allow reliable earthing. There shall be earth continuity between the outer shell and dome unless the outer shell is screened from live parts by double or reinforced insulation.

NOTE For the purpose of this requirement, small isolated metal screws and the like for fixing bases or covers are not deemed to be accessible parts which may become live in the event of an insulation fault.

Compliance is checked by the following test:

Lampholders provided with an earthing terminal are fitted with a rigid conductor of the smallest cross-sectional area for which the lampholder is intended. In case the earth continuity between outer shell and dome has also to be checked, the coupling between these parts shall be tightened with a torque equivalent to the test values given under 15.3.

Immediately after the electric strength test of 14.3, the resistance between the means of earthing and the dome (outer shell) is measured. In the case of lampholders provided with an earthing terminal, this is done between the point where the conductor leaves the earthing terminal and the dome (outer shell).

In the case of lampholders without an earthing terminal, this is done between that area of the lampholder where it is earthed in the luminaire and the dome (outer shell).

A current of at least 10 A, derived from a source with a no-load voltage not exceeding 12 V, shall be passed for 1 min between the earthing terminal or earthing contact and each of the accessible metal parts in turn.

The voltage drop between the earthing terminal or earthing contact and the accessible metal part shall be measured and the resistance calculated from the current and the voltage drop. In no case shall the resistance exceed 0,1 Ω .

11.4 The metal of earthing terminals shall be such that there is no risk of corrosion resulting from contact with the copper of the earthing conductor.

The screw or the body of the earthing terminal shall be of brass or other material no less resistant to corrosion, and the contact surface shall be bare metal.

Compliance is checked by inspection.

NOTE The risk of corrosion is particularly great when copper is in contact with aluminium.

12 Construction

12.1 The contact-making faces shall be smooth and so shaped at their edges that they do not prevent the easy insertion and removal of a corresponding lamp.

The contact profiles shall be in accordance with sheets 7005-10 (B22) or 7005-16 (B15) of IEC 60061-2.

Associated resilient means shall provide adequate contact force. The contact force for each contact shall comply with the values shown in Table 3.

Table 3 – Limits for contact forces

Rated current A	Contact force N	
	min	max
≤ 4	2,5	15
>4	5	20

Compliance is checked by inspection and by measurement in accordance with sheets 7005-10 or 7005-16 of IEC 60061-2.

The contact force is checked by means of the gauges shown on sheets 7006-15A (B22d) and 7006-15B (B15d) of IEC 60061-3.

This test shall be repeated following the test of 18.2.

12.2 The various parts of a lampholder shall be reliably connected together. Devices for fixing shades shall be so designed that the lampholder will not be dismantled by rotating the shade ring.

In cord grip or threaded entry lampholders where protection against accidental contact with live parts is provided by a dome screwing directly on to a body, or by a dome or other parts secured by a union ring, such parts shall be attached by at least one and three-quarter turns of thread.

Compliance is checked by inspection and by the tests specified in 15.3.

12.3 Where provision is made for a screwed type of shade ring, the outer edge of the ring shall be designed to facilitate turning by hand.

Compliance is checked by inspection.

12.4 Where a union ring is used it shall be designed to facilitate turning by hand. It shall retain the parts of the lampholder in concentric positions and the design shall be such as to prevent relative rotation of those parts.

Compliance is checked by inspection.

12.5 If the construction incorporates a separate interior member which supports the current-carrying parts, it shall be keyed in such a way as to prevent rotation with respect to the other parts of the lampholder.

Compliance is checked by inspection.

12.6 There shall be adequate space for the supply wires in the dome of the lampholder. Parts of the lampholder with which insulated conductors may come into contact shall have no sharp edges or a shape likely to damage the insulation.

Threaded entry lampholders with a dome shall be provided with means to prevent the conduit entering too far into the dome.

Such means can either be part of the lampholder or be provided by the design of a luminaire.

NOTE If such means are provided by the design of a luminaire, their efficiency cannot be checked when testing the lampholder; such a check should be made during testing of the luminaire. Such lampholders are not intended for retail sale.

Compliance is checked by inspection and,

- *for cord-grip lampholders, B15d lampholders and B22d lampholders with M10x1 thread, by fitting cables or cords of the largest cross-sectional area according to 10.2 and;*
- *for other B22d lampholders, by fitting conductors with a cross-sectional area one size less than the specified maximum cross-sectional area.*

For cord-grip lampholders, an ordinary sheathed flexible cord is used. In all other cases, two or three PVC insulated single-core cables are used.

For threaded entry lampholders, the dome of the lampholder is screwed on to a conduit having a length of about 100 mm. The cables then are introduced into the conduit and dome, and clamped at the free end of the conduit.

The ends of the cables, after having been prepared in the usual manner, are cut to a length just sufficient to make connection possible, and connected to the terminals of the lampholder. The clamping on the conduit is removed and the cables and the body are moved along a distance of 10 mm in the direction of the conduit.

After this, the cables are again clamped at the free end of the conduit and the lampholder is assembled.

After dismantling, the cables and cords shall not be damaged.

NOTE The requirement concerning the sharp edges is not meant for the screw ends of threaded entries if they are not in contact with the wires when the lampholder is mounted on a conduit.

In case of doubt with regard to the means to prevent the conduit entering too far into the dome of a threaded entry lampholder, the lampholder is fixed, as in normal use, to an appropriate nipple or conduit and is then subjected for 1 min in a clockwise direction to the following torque:

- *1,0 Nm for threads M10×1;*
- *1,3 Nm for threads M13×1.*

After this test, the nipple or conduit shall not have entered into the space provided for the supply wires in the dome of the lampholder and the lampholder shall not show any change impairing its further use.

12.7 It shall be possible to lock the threaded entry on the conduit. Such device can either be part of the lampholder or be provided by the design of a luminaire.

Except for angle lampholders, it shall be possible to operate the locking device from the inside, if provided as part of the lampholder.

NOTE If such means are provided by the design of a luminaire, their efficiency cannot be checked when testing the lampholder; such a check should be made during testing of the luminaire. Such lampholders are not intended for retail sale.

Compliance is checked by inspection and, for lampholders having an integral locking device, by the test of 15.2.

12.8 Cord grip lampholders shall be provided with a device allowing the lampholder to be so fixed to a flexible cord that the conductors are relieved from strain, including twisting, where they are connected to the terminals, and that the outer covering of the cord is gripped in the lampholder and protected from abrasion.

NOTE Only in the following countries: Poland and the United Kingdom, labyrinth type cord restraints, which do not grip the outer covering of the cord, may be utilized provided they meet the test requirements of this standard.

It shall be clear how the relief from strain and the prevention of twisting is intended to be effected.

It shall not be possible to push the cord into the lampholder to such an extent that the cord is subjected to undue mechanical or thermal stress.

Makeshift precautions, such as tying the cord into a knot or tying the end with string, are not permissible.

The device shall be of insulating material or be provided with a fixed insulating lining, if otherwise an insulation fault on the cord could make accessible metal parts live.

The design shall be such that the device:

- has at least one part fixed to or integral with the lampholder;
- is suitable for the different types of flexible cord which may be connected to the lampholder;
- does not exert excessive pressure on the cord;
- is unlikely to be damaged when it is tightened or loosened as in normal use.

The device shall be suitable for flexible cords of any one of the following types:

- 60245 IEC 51, or
- 60245 IEC 53, or the like,
- 60227 IEC 52.

Compliance is checked by inspection and by the following test:

The lampholder is fitted with one of the flexible cords mentioned above, the device for strain and twist relief being appropriately used. The conductors are introduced into the terminals and the terminal screws are slightly tightened so that the conductors cannot easily change their position. After this preparation, it shall not be possible to push the cord further into the lampholder.

The flexible cord is then subjected 100 times to a pull of the appropriate value shown in the table below for a duration of 1 s each. The pull shall not be applied in jerks.

Immediately afterwards, the flexible cord is subjected for a period of 1 min to a torque as specified in Table 4 applied as close as is practical to the cord entry in the most unfavourable direction:

Table 4 – Pull and torque values

Total nominal cross-sectional area of all conductors together mm ²	Pull N	Torque Nm
Up to and including 1,5	60	0,15
Over 1,5 up to and including 3	60	0,25
Over 3 up to and including 5	80	0,35
Over 5 up to and including 8	120	0,35

The lampholders are tested with each of the appropriate types of cord, as specified above, complying with IEC 60245 or IEC 60227.

The test is made first with conductors of the smallest cross-sectional area specified in 10.2, and then with conductors of either the largest cross-sectional area allowed by the suspending device or the largest cross-sectional area specified in 10.2, whichever is the smaller.

During the test, no damage shall be caused to the flexible cord by the device for strain and twist relief. At the end of the test, the cord shall not have been displaced by more than 2 mm, and the ends of the conductors shall not have been noticeably displaced in the terminals.

In order to enable the displacement to be measured, before starting the test a mark is made on the cord under strain at a distance approximately 20 mm from the strain-relieving device. At the end of the test, the displacement of this mark in relation to the strain-relieving device is measured while the cord is still under strain.

12.9 Suspension devices of enclosed and independent lampholders shall have no accessible metal parts which can become live, even in the event of a fault in the lampholder. Moreover, suspension devices intended to be screwed into threaded entry lampholders shall comply with the requirements of 12.8.

12.10 Where provision for cable entry/entries is made on the accessible external surface of a backplate lampholder it shall allow the introduction of cable covering, conduit or trunking etc., as appropriate, so as to afford mechanical protection for at least a distance of 1 mm measured from the accessible external surface of the backplate lampholder.

Compliance is checked by measurement and by the installation test of 10.2.

NOTE To meet this requirement, use may be made of knock-outs placed side by side or concentrically.

12.11 The base of backplate lampholders, other than those specifically intended for building-in, shall be suitable for fixing by means of screws with a diameter of at least 4 mm.

Compliance is checked by means of a gauge according to Figure 3. For this test, the plug is inserted into the hole from the back and the bush is placed on the plug from the front. The bush shall enter the recess of the screw head.

12.12 Insulating barriers forming an integral part of the lampholder shall be provided between the terminals if these are of the rising type to prevent inadvertent contact between conductors at different potentials. This applies whatever the range of movement of the terminals.

Terminals of the rising type are not permitted in backplate lampholders other than those specifically intended for building-in.

Compliance is checked by inspection and by the tests of Clause 17.

12.13 Lampholders shall not be fitted with a socket-outlet.

Compliance is checked by inspection.

13 Switched lampholders

13.1 Switches are allowed only in ordinary lampholders.

Compliance is checked by inspection.

13.2 The lampholder shall be so constructed that accidental contact between moving parts of the switch and the supply conductors is prevented.

Compliance is checked by the test of 10.4 and by a manual test.

13.3 The switch operating member shall be effectively insulated from live parts and, if broken or damaged, shall not expose live parts.

Compliance is checked by inspection and by the tests of 13.4.

13.4 Switches in lampholders shall be capable of making and breaking a load comprising a general lighting service (GLS) tungsten filament lamp at rated voltage.

Compliance is checked by the following tests.

For lampholders without temperature marking or marked Txxx, the switch is tested in a heating cabinet with a.c. ($\cos \varphi = 0,6 \pm 0,05$) at 1,1 times rated voltage and 1,25 times rated current. The switch shall be operated in a normal manner for 200 switch movements at a rate of 30 movements per minute at regular intervals.

The switch is then tested with a.c. ($\cos \varphi = 1$) at rated voltage and rated current.

The switch shall be operated in a normal manner for 20 000 switch movements at a rate of 30 movements per minute at regular intervals.

NOTE This test is based on the requirements of IEC 60238. Its replacement by the corresponding test of IEC 61058-1 is under consideration.

Switches in lampholders B15d without temperature marking shall be tested for an operating temperature of 100 °C and switches in lampholders B22d without temperature marking shall be tested for an operating temperature of 125 °C.

Switches in lampholders with Txxx marking shall be tested for operating temperatures as follows:

- *lampholders B15d: the temperature marking on the lampholder minus 40 °C;*
- *lampholders B22d: the temperature marking on the lampholder minus 50 °C.*

For T1 and T2 rated lampholders, the lampholder shall be mounted in a shade and placed in a draught-free enclosure as described in 18.5. Suitable access apertures may be made to enable the switch to be operated, but such apertures shall be as small as possible to maintain the required testing conditions.

Voltage adjustments shall be made as described in item a) of 18.6, and the temperature of the lamp cap shall be maintained within the specified T1 or T2 testing temperature limits for 2 h immediately before the switching test.

The switch shall then be operated in a normal manner for 20 000 switch movements at a rate not exceeding 12 movements per minute at regular intervals.

At the conclusion of the test, the lampholders shall withstand the tests specified in 14.3 for insulation resistance and electric strength and they shall be in satisfactory working order.

14 Moisture resistance, insulation resistance and electrical strength

14.1 The enclosure of drip-proof lampholders shall provide the necessary degree of protection against ingress of water.

Inlet openings of drip-proof lampholders shall allow the connection of the supply wires in such a way that drops of water running along the wires cannot reach the inside of the lampholder.

Compliance is checked by the following test:

Lampholders are fitted with the cables or conduits for which they are designed.

Backplate lampholders are mounted on a vertical surface with one drain-hole, if any, open and directed downwards. Other lampholders are mounted with their lamp entry pointing vertically downwards.

The test is made by means of equipment, the principle of which is shown in Figure 3 of IEC 60529; the rate of discharge shall be reasonably uniform over the whole area of the apparatus and shall produce a rainfall of between 3 mm and 5 mm of water per minute, falling vertically from a height of 200 mm measured from the lampholder. The test duration shall be 10 min. The water used for the test shall be at a temperature of $15\text{ °C} \pm 10\text{ °C}$.

Immediately after this treatment, the lampholder shall withstand the same electric strength test as specified in 14.3, and inspection shall show that water has not entered to an appreciable extent.

NOTE It is considered that water has entered to an appreciable extent if it has come into contact with live parts.

14.2 Lampholders shall be proof against humid conditions which may occur in normal use.

Compliance is checked by the humidity treatment described in this subclause followed immediately by the measurement of the insulation resistance and by the electric strength test specified in 14.3.

Cable entries, if any, are left open; if knock-outs are provided, one of them is opened.

The humidity treatment is carried out in a humidity cabinet containing air with a relative humidity maintained between 91 % and 95 %.

The temperature of the air, at all places where samples can be located, is maintained within 1 °C of any convenient value t between 20 °C and 30 °C .

Before being placed in the humidity cabinet, the specimens are brought to a temperature between $t\text{ °C}$ and $(t + 4)\text{ °C}$.

Lampholders are kept in the cabinet during:

- 2 days (48 h) for ordinary lampholders;
- 7 days (168 h) for IPX1 drip-proof lampholders.

NOTE In most cases, the specimens may be brought to the specified temperature by keeping them at this temperature for at least 4 h before the humidity treatment.

Relative humidity between 91 % and 95 % can be obtained by placing in the humidity cabinet a saturated solution of sodium sulphate (Na_2SO_4) or potassium nitrate (KNO_3) in water having a sufficiently large contact surface with the air. In order to achieve the specified conditions within the cabinet, it is necessary to ensure constant circulation of the air within and, in general, to use a cabinet which is thermally insulated.

After this treatment, the lampholders shall show no damage within the meaning of this standard.

14.3 The insulation resistance and the electric strength shall be adequate:

- a) between live parts of different polarity;

NOTE For the purposes of this subclause, switch contacts in the open position are considered to be live parts of different polarity.

- b) between such live parts and external metal parts, including fixing screws of base or enclosure of backplate lampholders and accessible assembling screws;
- c) between the inner and outer surfaces of the lining of metal enclosures, if such accessible lining is required to give protection in the case that the distance between any live part and the metal of the enclosure is smaller than that required under item 2 in Table 8.

Compliance is checked by an insulation resistance test and an electric strength test, which are applied immediately after the humidity treatment of 14.2 in the humidity cabinet, or in the room in which the specimens were brought to the prescribed temperature.

The insulation resistance is measured with a d.c. voltage of approximately 500 V, the measurement being made 1 min after application of the voltage.

The insulation resistance is measured consecutively:

- between live parts of different polarity;
- between such live parts connected together and external metal parts, fixing screws of the base and of the enclosure, accessible assembling screws and metal foil in contact with the surface of external insulating parts.

Both of the measurements prescribed above are made first on the lampholder in which a test cap as shown in Figure 10 or 11 is inserted and then on an empty lampholder;

- between accessible metal parts and metal foil in contact with the inner surface of insulating lining, if any.

The switch, if any, is placed in the "on" position.

The insulation resistance shall not be less than 4 M Ω . This value may be reduced to 2 M Ω for the measurement between live parts of different polarity.

Care should be taken to ensure that the insulating material of the test cap will not influence the results.

Immediately after the insulation resistance test, an a.c. voltage of substantially sine wave form, with a frequency of 50 Hz or 60 Hz and with a r.m.s. value of $(2 U + 1\,000)$ V (where U is the rated voltage) is applied for 1 min between the points prescribed. Additionally, for

switched lampholders, this voltage shall be applied between live parts and other metal parts with the switch both closed and open.

Initially, not more than half the prescribed voltage is applied, then it is raised rapidly to the full value.

No flashover or breakdown shall occur.

NOTE The high-voltage transformer used for the test must be so designed that, when the output terminals are short-circuited after the output voltage has been adjusted to the appropriate test voltage, the output current is at least 200 mA.

The overcurrent relay shall not trip when the output current is less than 100 mA.

Care is taken that the r.m.s. value of the test voltage applied is measured within $\pm 3\%$.

Glow discharges without drop in voltage are ignored.

15 Mechanical strength

15.1 Lampholders shall have sufficient strength to withstand the stresses of normal operation in service.

NOTE Brackets or similar devices for the mounting or attachment of lampholders are not covered by the requirements of this clause. The mechanical strength of such devices shall comply with the requirements of the standard for the equipment for which the lampholder is intended.

Compliance is checked by the following tests:

The lampholder shall be supported in any convenient manner with the open end pointed vertically downwards. A mass of 5 kg shall be suspended evenly from the bayonet slots by means of a loading device as shown in Figure 1, so that the lampholder plungers will not make contact with it.

After 1 h, there shall be no deterioration in the lampholder such as would affect its normal use.

15.2 Threaded entry lampholders shall be so designed that mounting by means of the attachment thread is effective and will cause no damage to the lampholder rendering it unsafe in normal use.

Compliance is checked by the following test:

The lampholder is fixed, as in normal use, to an appropriate conduit and is subjected to the following torque:

- 1,2 Nm for B15d lampholders;*
- 2,0 Nm for B22d lampholders.*

The torque is applied for 1 min in a clockwise direction.

If the lampholder is fitted with a locking device with respect to the conduit, its efficiency shall be checked by repeating the above test for 1 min in an anti-clockwise direction; the set screws being tightened with a torque as specified in Clause 16. If, however, the lampholder loosens, the set screw is further tightened with the smallest torque necessary to prevent the lampholder from loosening during this test. The minimum value of the torque applied should be noted for the purpose of the test of Clause 16.

NOTE It is practical to increase the torque by increments of about 20 % during this test.

At the conclusion of the test, there shall be no deformation, damage to parts or loosening of the lampholder such as would render it unsafe in normal use.

15.3 External parts of lampholders when correctly assembled shall have adequate mechanical strength.

Compliance is checked by inspection and by the following tests:

Where protection against accidental contact with live parts is provided by a dome screwing directly on to a body or a dome secured by a union ring, or by other screwed parts of the exterior, such parts shall be removed and replaced by hand 10 times, tightening each time with a torque of:

- 0,75 Nm for B15d domes and union rings;
- 1,25 Nm for B22d domes and union rings;
- $(0,03 \times \text{diameter})$ Nm for other screwed parts of the exterior depending on their nominal outside diameter in millimetres.

NOTE The constant of 0,03 is derived from the test torques for domes and union rings of commonly known dimensions, and will enable relative torques to be calculated for components of other dimensions.

Where screwed shade rings or equivalent parts are provided, they shall be removed and replaced by hand 10 times, tightening each time with half the torque specified for domes and union rings.

Where protection against accidental contact with live parts is provided by a construction not assembled by the rotation of co-operating threaded components, such a construction shall be checked by dismantling and assembling the external protective parts 10 times and, after each assembly, by applying, between the bayonet slots and such parts, an axial torque of the same value as specified for domes and union rings. The torque shall be applied in a clockwise and in an anti-clockwise direction each time, sustaining the torque for 5 s upon each application.

During the tests, no change impairing the further use of any part shall have occurred and the protection against accidental contact with live parts shall not have been impaired.

15.4 *The strength of the connection between dome and threaded entry shall be checked as indicated in Figure 2.*

The specimen is fixed by the threaded entry in a horizontal position.

A device having the maximum dimensions acceptable for caps, and with other dimensions according to Figure 2, is inserted into the lampholder and fixed as shown in the drawing. It is loaded for 1 min with a mass, as indicated in Figure 2. The end of the mandrel shall not sag more than 5 mm.

The specimen shall not be damaged. If a permanent deformation occurs, the specimen is forced into the original position and the test is repeated five times, after which the specimen shall show no damage impairing its normal use.

15.5 *The mechanical strength of external parts of insulating material with or without a conductive outer surface is checked by means of the pendulum hammer test specified in IEC 60068-2-75, subject to the following details (see Clause 4 of IEC 60068-2-75):*

a) *Method of mounting:*

The specimen shall be held against the plywood sheet of the mounting fixture in such a manner that its axis is horizontal and parallel to the support and its outer edge touches the plywood.

NOTE For lampholders different from the cylindrical shape, the condition of the axis parallel to the plywood sheet may be obtained by adequate pine-wood shimmings.

b) *Height of fall:*

The striking element shall fall from one of the heights given in Table 5.

Table 5 – Heights of fall

Material	Height of fall mm
Ceramic parts	100 ± 1
Parts made of other material	150 ± 1,5

c) *Number of impacts:*

Four blows shall be applied to points equally divided over the circumference of the external parts of the lampholder excluding the area of the bayonet slots.

d) *Pre-conditioning:*

Not applicable.

e) *Initial measurements:*

Not applicable.

f) *Attitudes and impact locations:*

See c) above.

g) *Operating mode and functional monitoring:*

The sample shall not operate during impact.

h) *Acceptance and rejection criteria:*

After the test, the sample shall show no serious damage within the meaning of this standard, in particular:

1) *live parts shall not have become accessible.*

Damage to the lampholder which does not reduce creepage distances or clearances below the values specified in Clause 17 and small chips which do not adversely affect the protection against electric shock or ingress of water shall be ignored;

2) *cracks not visible to the naked eye and surface cracks in fibre-reinforced mouldings and the like shall be ignored.*

Cracks or holes in the outer surface of any part of the lampholder shall be ignored if the lampholder complies with this standard even if that part is omitted.

i) *Recovery:*

Not applicable.

j) *Final measurements:*

See h) above.

NOTE The mechanical strength of lampholders used in luminaires or other equipment may be checked by means of the spring hammer specified in IEC 60068-2-75. In IEC 60598-1, the test impact energy used varies from 0,2 Nm to 0,7 Nm depending on component material and luminaire type.

15.6 For metal lampholders the mechanical strength of external metal parts shall be tested by means of a pressure apparatus according to Figure 18.

The various parts are tested on the complete lampholder. Each part is subjected twice for 1 min to a force as indicated in the following table, the pressure being applied on two diameters at right angles to each other.

The test is not made on outer cases of insulating material with a conductive outer surface. Moreover, this test does not apply to the bayonet barrel.

During and after the test, the deformation of the specimen shall not exceed the values indicated in Table 6.

Table 6 – Maximum deformation values

Lampholder	Force N	Maximum deformation mm	
		During the test	After the test
B15	75	1	0,3
B22	100	2	0,3

15.7 Entry spouts and glands of drip-proof lampholders shall withstand the mechanical stresses occurring during normal fitting and use.

Compliance is checked by the following test:

Screwed glands are fitted with a cylindrical metal rod having a diameter equal to the nearest whole number of millimetres below the internal diameter of the packing.

The glands are then tightened by means of a suitable spanner, a force of 30 N for metal glands, or 20 N for glands of moulded material, being applied for 1 min at a radius of 250 mm.

At the end of the test, the glands, the spouts and the enclosures shall show no damage.

15.8 Backplate lampholders shall be so designed as to withstand fixing to a support without damage.

Compliance is checked by the following test:

The backplate of the lampholder is fixed by means of M4 screws or those of maximum insertable diameter to a rigid flat steel sheet. This sheet has two drilled and tapped holes at a distance equal to the distance between the axis of the fixing holes of the backplate. The screws are gradually tightened, the maximum torque applied being 1,2 Nm.

For backplate lampholders specifically intended for building-in, this test is carried out with the means of attachment specified by the manufacturer.

After this test, the backplate lampholder shall show no damage impairing its further use.

16 Screws, current-carrying parts and connections

Screws, current-carrying parts and mechanical connections, the failure of which might cause the lampholder to become unsafe, shall withstand the mechanical stresses occurring in normal use.

Compliance is checked by inspection and the tests of Section 4, Subclauses 4.11 and 4.12 of IEC 60598-1 except that the first line of Table 4.1 of IEC 60598-1 is replaced by Table 7.

Table 7 – Torque values

Nominal diameter of screw mm	Torque Nm	
	1	2
Up to and including 2,6	0,15	0,3
Over 2,6 up to and including 2,8	0,2	0,4

NOTES

- Screwed connections are already partially checked by the tests of Clause 16.
- For the material requirements shown in 4.11.4 of IEC 60598-1, the tests of Clauses 18 and 20 will show whether current-carrying parts are equivalent to copper in respect of current-carrying capacity, mechanical strength and corrosion resistance likely to be met in normal service.

17 Creepage distances and clearances

Creepage distances and clearances shall be not less than the values shown in Table 8, the lampholder being fitted as in normal use.

All distances apply in every position of the plunger.

NOTE 1 The distances specified in Table 8 apply to impulse withstand category II in accordance to IEC 60664-1 and refer to pollution degree 2, where normally only non-conductive pollution occurs but occasionally a temporary conductivity caused by condensation must be expected. For information on distances for other impulse withstand categories or higher pollution degrees, IEC 60598-1 and IEC 60664-1 should be consulted.

NOTE 2 Attention is drawn to the fact that the values for creepage distance and clearance given in this clause are the absolute minimum.

NOTE 3 The voltages shown in Table 8 are the rated voltage, not the ignition voltage.

Table 8 – Minimum distances for a.c. (50/60 Hz) sinusoidal voltages – Impulse withstand category II

Rated voltage 250 V	Distances mm
Between live parts of different polarity ^a , and Between live parts and external metal parts, if not covered with insulating material: (this includes screws of backplate lampholders) ^b - Creepage distances insulation PTI ^a ≥ 600 PTI ^a < 600 - Clearances ^d	 1,5 ^f 2,5 1,5 ^f
Clearances in case of backplate lampholders ^{c, e} - between live parts and the mounting surface, and - between live parts and the boundary of the space for the supply wires:	 3,6
NOTE Values for creepage distances and clearances may be found for intermediate values of working voltages by linear interpolation between tabulated values.	
a PTI (proof tracking index) in accordance with IEC 60112.	
b In the case of creepage distances to parts not energized or not intended to be earthed, where no tracking can occur, the values specified for material with PTI ≥ 600 apply for all materials (irrespective of the real PTI). For creepage distances subjected to working voltages of less than 60 s duration, the values specified for materials with PTI ≥ 600 apply for all materials.	
c For creepage distances not liable to contamination by dust or moisture the values specified for material with PTI ≥ 600 apply (independently of the real PTI)	
d For B15 lampholders the clearance is reduced to 1,4 mm.	
e These values take account of possible unevenness of the mounting surface.	
f For Japan, minimum distance is 1,7 mm.	

Compliance is checked by measuring with and without supply wires of the largest cross-sectional area according to 10.2, connected to the terminals.

18 General resistance to heat

18.1 Lampholders shall be sufficiently resistant to heat.

Compliance is checked:

- *for lampholders without temperature marking or marked Txxx, by the tests of 18.2, 18.3 and 18.4;*
- *for lampholders marked T1 or T2, by the tests of 18.3, 18.5, 18.6 and 18.7.*

18.2 *Lampholders without temperature marking shall be tested first in a heating cabinet at the temperature indicated in Table 9.*

Table 9 – Heating cabinet temperature

Lampholder	Temperature °C
B15d	145
B22d	175

Lampholders marked Txxx shall be tested at the marked temperature plus 10 K.

For lampholders which form an integral part of the luminaire, this temperature is replaced by that measured according to the operating conditions given in 12.4.2 of IEC 60598-1, plus 10 K, with a tolerance of ± 5 °C.

For this test, a solid steel test cap shall be inserted into the lampholder in vertical lampholder-up position because the weight of the test cap must not bear on the lampholder. In the area of the contacts, the test cap shall comply with maximal dimensions in accordance with the current edition of standard sheets 7004-10 (B22d/22) and 7004-11 (B15d/19) of IEC 60061-1.

The temperature is maintained with a tolerance of ± 5 K for 48 h without interruption.

After cooling down for 24 h, without the test cap, the contact force test shall be repeated in accordance with 12.1.

18.3 Contacts and all other current-carrying parts shall be so constructed as to prevent excessive temperature rise.

Compliance is checked by the following test which shall be made immediately after the test of 18.2 on the lampholders in whose terminals conductors of the maximum cross-sectional area according to 10.2 are fitted.

The terminal screws shall be tightened with a torque equal to two-thirds of the torque specified in Clause 16; the lampholder is placed with the open end downwards and loaded for 1 h with 1,25 times its rated current. The temperature rise of terminals shall not exceed 45 K.

This temperature is determined with the aid of melting particles or by thermocouples, not by means of a thermometer.

For this test, a special test cap as shown in Figure 5 (B15d) or Figure 6 (B22d) is used. Before the test, the contact surface is carefully cleaned and polished.

NOTE Pellets of beeswax (diameter 3 mm, melting temperature 65 °C) may be used as melting particles provided that the ambient temperature equals 20 °C.

After the test, the conductors shall not be damaged.

18.4 *The resistance to heat is then tested in a heating cabinet at the temperature indicated in Table 10.*

Table 10 – Heating cabinet temperature

Lampholder	Temperature
	°C
B15d	170
B22d	200

Lampholders marked Txxx shall be tested at the marked temperature plus 35 K.

Lampholders which form an integral part of the luminaire shall be tested at the temperature measured in the luminaire according to 12.4.2 of IEC 60598-1, plus 35 K, with a tolerance of ± 5 C.

For this test, a solid steel (preferably stainless steel) test cap is inserted into the lampholder. In the area of the contacts, the test cap shall comply with maximal dimensions in accordance with the current edition of the standard sheets 7004-10 (B22d/22) and 7004-11 (B15d/19) of IEC 60061-1.

The lampholder, with the test cap inserted is placed in the vertical lampholder-up position (because the weight of the test cap must not bear on the lampholder) in a heating cabinet having approximately half the temperature specified in the table. This temperature is raised to the required test temperature within $1\text{ h} \pm 15\text{ min}$. Following this, the test is continued for 168 h without interruption. The test temperature is maintained with a tolerance of ± 5 K.

During the test, the lampholder shall not undergo any change impairing its further use especially in the following respects:

- *reduction of the protection against electric shock;*
- *loosening of electrical contacts;*
- *cracks, swelling or shrinking;*
- *sealing compound flowing out.*

The test cap is removed from the lampholder after cooling down to approximately room temperature.

After the test, the lampholder is examined to determine that:

- the shade ring or skirt, if provided, is removable and replaceable without damage;

Compliance is checked by inspection and manual test.

- there is no deformation which could affect the safety or further use of the lampholder;

Compliance is checked by the application of the gauges according to standard sheets 7006-12C and 7006-12D (B15d) and 7006-12A and 7006-12B (B22d) of IEC 60061-3.

The use of the gauge is not intended for checking the reality of the contact, but only for checking the possible deformation of moulded materials.

NOTE Any deterioration of the lampholder (including discoloration of any part) which does not affect its safety may be ignored.

In addition, the lampholder shall withstand the mechanical strength test made under the conditions specified in 15.2, 15.3 and 15.5, the torque being reduced however to 50 % of the original value and the height of fall being reduced to 50 mm.

18.5 Lampholders marked T1 or T2 shall be tested with an open-ended cylindrical metal shade with an unventilated internal barrier and the dimensions as shown in Figure 12. The barrier may be removable to facilitate the examination of the lampholder after test.

The lampholder shall be wired with 0,5 mm² conductors having suitable heat-resistant insulation.

Lampholders shall be mounted for test, within the shade, in a manner appropriate to their construction, as follows:

a) All lampholders

The arrangement shall be such as to ensure that the lamp is positioned below the lampholder with its axis approximately aligned with the vertical axis of the test shade.

b) Lampholders having shade-carrier devices

The metal test shade shall be suspended from the lampholder by the normal use of the shade-carrier device, external screwed parts being tightened with the appropriate torque values specified in 15.3, except that a screwed shade-carrier device shall then be loosened by one-eighth of a turn before commencing the test described in 15.6.

c) Lampholders not having shade-carrier devices

The lampholder shall be mounted by its intended mounting means on the underside of the internal barrier of the metal test shade.

NOTE Where necessary, an additional device such as a threaded nipple or a special mounting bracket may be used.

The complete assembly shall then be suspended, by means of the 0,5 mm² test wires, approximately in the centre of the draught-free enclosure detailed in Figure 12.

Each lampholder shall be tested using a new, coiled coil, frosted or white internally coated lamp in accordance with IEC 60432. Other details of the test lamp shall be as specified in Table 11 of this standard.

A thermocouple shall be affixed to the lamp cap at a position 3 mm above the lamp glass-to-cap junction and as nearly as possible over the centre of the lamp filament.

The leads to this thermocouple shall be connected to a temperature indicator or a temperature sensitive device which will enable the lamp cap temperature shown in Table 11 to be measured. The supply to the lamp shall be controlled to achieve and maintain these temperatures. Care shall be taken in fixing the thermocouple to ensure that intimate contact is made with the lamp cap.

18.6 The test procedure shall be as follows:

a) Preparation

Determine the relevant lamp rating and test temperature from Table 11, then assemble the lampholder in the test shade and cabinet, as specified in 18.5, and fit the test lamp with the thermocouple attached. Connect a supply to the lamp and adjust the voltage until a steady temperature is maintained on the lamp cap within the tolerance specified in Table 11, at a voltage not exceeding 110 % of the rated lamp voltage. At this stage the first 40 h test period shall commence.

NOTE Owing to possible variations in lamp characteristics it may be necessary to change the test lamp for another, of the same specification, to achieve the specified temperature within permitted voltage limits.

b) Cycling test

The complete test shall comprise 12 consecutive cycles or 25 consecutive cycles, as specified in Table 11, each cycle consisting of three consecutive periods:

- 1) a period of 40 h, with the supply switched on, during which the test temperature shall be maintained within the specified limits;
- 2) a period of not less than 2 h with the supply switched off, during which the lamp cap temperature shall fall to the ambient level;
- 3) a period of not less than 1 h with the supply switched on, during which the lamp cap test temperature shall be re-established.

In the event of failure of the test lamp, the time required for re-establishing the temperature after replacing the lamp shall not be taken as part of the test.

Table 11 – Test temperature and test lamp data

Lampholders marked T1 or T2					
Marking	Lampholder material	Lamp cap temp. +0, –10 °C	Number of cycles	Holder type	Test lamp data
					Watt rating W
T1	Plastic, ceramic or metal	175	12	B15d B22d	60 100
T2	Incorporating plastic parts*	220	25	B15d B22d	60 150
T2	Not incorporating plastic parts*	220	12	B15d B22d	60 150
NOTE 1 The temperature of 220 °C $\begin{smallmatrix} +0 \\ -10 \end{smallmatrix}$ °C specified above is chosen to prove the performance of T2 lampholders under test conditions and is not to be confused with the limiting temperature for lamp operation in service specified in IEC 60432.					
NOTE 2 12 periods equal 480 h at the test temperature; 25 periods equal 1 000 h at the test temperature.					
* Other than cord grip devices of plastic material.					

18.7 After the test specified in 18.6, and after having cooled to room temperature, the lampholders shall be examined to determine the following:

- a) the lampholder is not so deformed as to prevent the proper acceptance of a corresponding lamp cap having maximum or minimum dimensions according to IEC 60061-1;

Compliance is checked by the application of the gauges specified in IEC 60061-3, i.e. standard sheets 7006-12A and 7006-12B (B22d) and standard sheets 7006-12C and 7006-12D (B15d).

- b) the shade ring, or skirt, or protective shield, if provided, is removable and replaceable without damage;

Compliance is checked by inspection and by removing and replacing the shade ring, skirt or protective shield.

- c) metal parts attached to insulated parts are still held securely;

Compliance is checked by inspection.

- d) the force required to depress each contact mechanism is still satisfactory;

Compliance is checked by repeating the test described in 12.1.

- e) the requirements of the insulation resistance and electric strength tests described in 14.3 are met.

The requirements for parts providing protection against accidental contact with live parts shall be checked by repeating the appropriate tests described in 9.1 and 15.3.

NOTE Any deterioration of the lampholder (including discoloration of any part) which does not affect its safety may be ignored.

19 Resistance to heat, fire and tracking

19.1 Parts retaining the contacts and external parts of lampholders of insulating material and of lampholders comprising external parts of insulating material with a conductive outer surface shall be resistant to heat.

For materials other than ceramic, compliance is checked with the aid of the ball-pressure test by means of the apparatus shown in Figure 17.

The tests required by Clause 19 of this standard are not performed on lampholders which are integral with a luminaire, as similar tests are required in Section 13 of IEC 60598-1. However, the operating conditions of these tests will take into account the conditions specific to lampholders as also defined in Clause 19 of this standard.

The surface of the part under test is placed in the horizontal position and a steel ball of 5 mm diameter is pressed against this surface with a force of 20 N.

For lampholders without temperature marking or marked Txxx, this test is made in a heating cabinet at a temperature shown in 18.4.

For lampholders marked T1 or T2, the test is made at a temperature of 125 °C ± 5 °C.

NOTE If, in the testing of the luminaire (see 12.4 of IEC 60598-1) temperatures exceeding 100 °C are measured on the above-mentioned parts, the test is repeated with a temperature 25 °C ± 5 °C in excess of that temperature.

The test load and the supporting means are placed within the heating cabinet for a sufficient time to ensure that they have attained the stabilized testing temperature before the test commences.

The part to be tested is placed in the heating cabinet for a period of 1 h, before the test load is applied.

If the surface under test bends, the part where the ball presses is supported. For this purpose, if the test cannot be made on the complete specimen, a suitable part may be cut from it.

The specimen shall be at least 2,5 mm thick, but if such a thickness is not available on the specimen then two or more pieces are placed together.

After 1 h, the ball is removed from the specimen which is then immersed within 10 s in cold water for cooling down to approximately room temperature. The diameter of the impression caused by the ball is measured and shall not exceed 2 mm.

NOTE In the event of curved surfaces, such as lampholder shells, the shorter axis is measured if the indent is elliptical.

In case of doubt, the depth of the impression is measured and the diameter ϕ calculated using the formula: $\phi = 2\sqrt{p(5-p)}$ in which p = depth of impression.

19.2 External parts of insulating material (outer shell, bayonet barrel, dome or backplate), including those with a conductive exterior providing protection against electric shock, and parts of insulating material (terminal/contact assembly) retaining live parts in position, shall be resistant to flame and ignition.

For materials other than ceramics, compliance is checked by the tests of 19.3 and 19.4

19.3 *External parts of insulating material providing protection against electric shock including those with a conductive exterior, are subjected to the glow-wire test in accordance with IEC 60695-2-11, subject to the following details:*

- *The specimen is a complete lampholder. It may be necessary to take away parts of the lampholder to perform the test, but care should be taken to ensure that the test conditions are not significantly different from those occurring in normal use.*
- *The specimen is mounted on the carriage and pressed against the glow-wire tip with a force of 1 N, preferably 15 mm, or more, from the upper edge, into the centre of the surface to be tested. The penetration of the glow-wire into the specimen is mechanically limited to 7 mm.*

If it is not possible to make the test on a specimen as described above because the specimen is too small, the test is made on a separate specimen of the same material, 30 mm × 30 mm square and with a thickness equal to the smallest thickness of the specimen and manufactured by a similar process.

- *The temperature of the tip of the glow-wire is 650 °C. After 30 s, the specimen is withdrawn from contact with the glow-wire tip. The glow-wire temperature and heating current are constant for 1 min prior to commencing the test. Care should be taken to ensure that heat radiation does not influence the specimen during this period. The glow-wire tip temperature is measured by means of a sheathed fine wire thermocouple constructed and calibrated as described in IEC 60695-2-11.*
- *Any flame or glowing of the specimen shall extinguish within 30 s of withdrawing the glow-wire and any flaming drops of the material shall not ignite a piece of tissue paper, as specified in definition 4.187 of ISO 4046-4, spread out horizontally 200 mm ± 5 mm below the specimen.*

19.4 *Parts of insulating material retaining live parts in position are subjected to the needle-flame test in accordance with IEC 60695-11-5, subject to the following details.*

- *The specimen is a complete lampholder. It may be necessary to take away parts of the lampholder to perform the test, but care should be taken to ensure that the test conditions are not significantly different from those occurring in normal use.*
- *The test flame is applied to the centre of the surface to be tested.*
- *The duration of application is 10 s.*
- *Any self-sustaining flame shall extinguish within 30 s of removal of the gas flame and any flaming drops of the material shall not ignite a piece of tissue paper, as specified in definition 4.187 of ISO 4046-4, spread out horizontally 200 mm ± 5 mm below the specimen.*

19.5 For lampholders other than ordinary lampholders, insulating parts retaining live parts shall have adequate resistance to tracking.

For materials other than ceramic, compliance shall be checked by the proof tracking test in accordance with IEC 60112, subject to the following details.

- *If the specimen has no flat surface of at least 15 mm × 15 mm, the test may be carried out on a flat surface with reduced dimensions provided drops of liquid do not flow off the specimen during the test.*

No artificial means should, however, be used to retain the liquid on the surface. In the case of doubt, the test may be made on a separate strip of the same material, having the required dimensions and manufactured by the same process.

- *If the thickness of the specimen is less than 3 mm, two, or if necessary, more, specimens should be stacked to obtain a thickness of at least 3 mm.*
- *The test shall be made at three places of the specimen or on three specimens.*
- *The electrodes shall be of platinum and test solution A, as described in 7.3 of IEC 60112, shall be used.*
- *The specimen shall withstand 50 drops without failure at a test voltage of PTI 175.*
- *A failure has occurred if a current of 0,5 A or more flows for at least 2 s in a conducting path between the electrodes on the surface of the specimen, thus operating the overcurrent relay, or if the specimen burns without releasing the overcurrent relay.*
- *Clause 9 of IEC 60112 regarding determination of erosion, does not apply.*

20 Resistance to excessive residual stresses (season cracking) and to rusting

20.1 Contacts and other parts of rolled sheets of copper or copper alloy whose failure might cause the lampholder to become unsafe shall not be damaged due to excessive residual stresses.

Compliance is checked by the following test:

The surface of the specimens is carefully cleaned, varnish being removed by acetone, and grease and finger prints by petroleum spirit or the like.

The specimens are placed for 24 h in a test cabinet, the bottom of which is covered by an ammonium chloride solution having a pH value of 10 (for details of the test cabinet, the test solution and the test procedure, see Annex A).

After this treatment, the specimens are washed in running water; 24 h later, they shall show no cracks when inspected at an optical magnification of 8 ×.

Cracks which may occur in very restricted areas of the outer shell of metal lampholders near the fixing areas of the insulating ring shall not be considered.

In order not to influence the results of the test, the specimens shall be handled with care.

20.2 Ferrous parts, the rusting of which may endanger the safety of the lampholder, shall be adequately rust protected.

Compliance is checked by the following test:

All grease is removed from parts to be tested by immersion in a suitable degreasing agent for 10 min. The parts are then immersed for 10 min in a water solution of 10 % ammonium chloride at a temperature of $20\text{ °C} \pm 5\text{ °C}$.

Without drying, but after shaking off drops of water, the parts are placed for 10 min in a box containing air saturated with moisture at a temperature of $20\text{ °C} \pm 5\text{ °C}$.

After the parts have been dried for 10 min in a heating cabinet at a temperature of $100\text{ °C} \pm 5\text{ °C}$, any traces of rust on sharp edges and any yellowish film may be removed by rubbing, after which their surface shall show no signs of rust.

For small helical springs and the like, and for ferrous parts exposed to abrasion, a layer of grease is deemed to provide sufficient rust protection. Such parts are not subjected to the test.

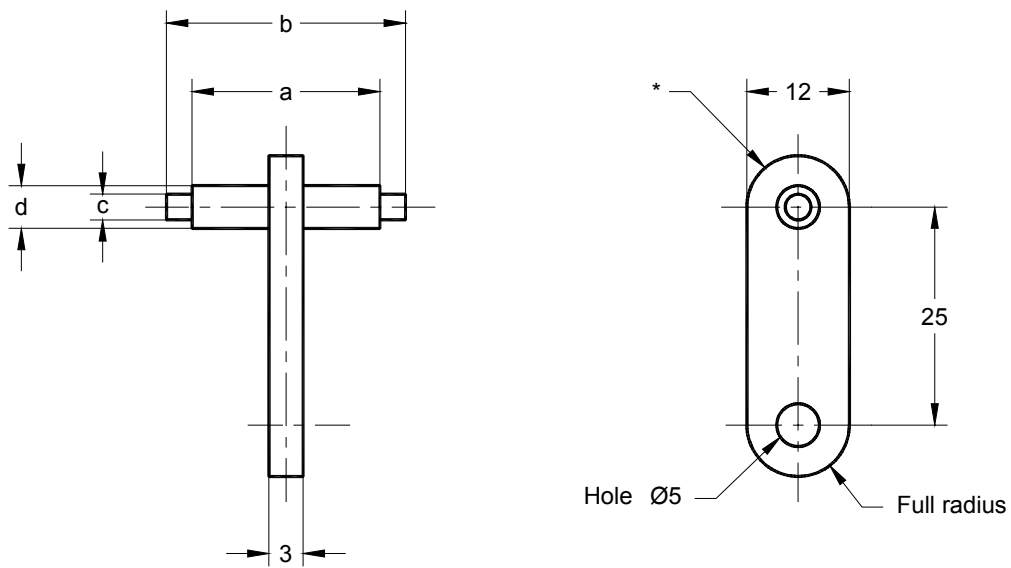
Dimensions in millimetres

IEC 1074/08

* This radius may need local modification to clear lampholder contact.

Reference	Dimension		Tolerance
	B15d	B22d	
a	14	21	+0,05 -0,05
b	17,5	27,5	+0,5 -0,5
c	2,5	2,5	+0,05 -0,05
d	5	5	+0,05 -0,05

Figure 1 – Loading device (see 15.1)

Dimensions in millimetres

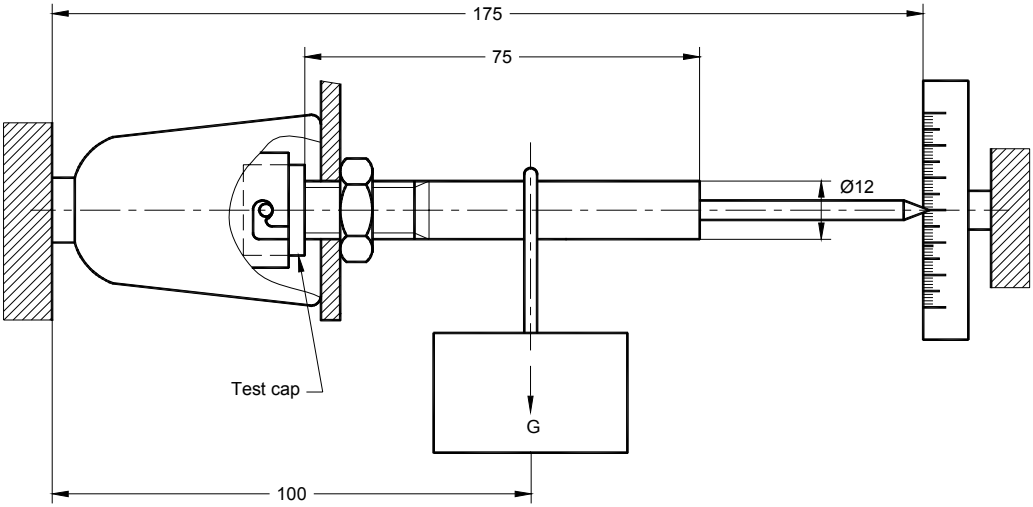

IEC 1075/08

Lampholder	G kg
B15d	1
B22d	2

Figure 2 – Bending apparatus (see 15.4)

Dimensions in millimetres

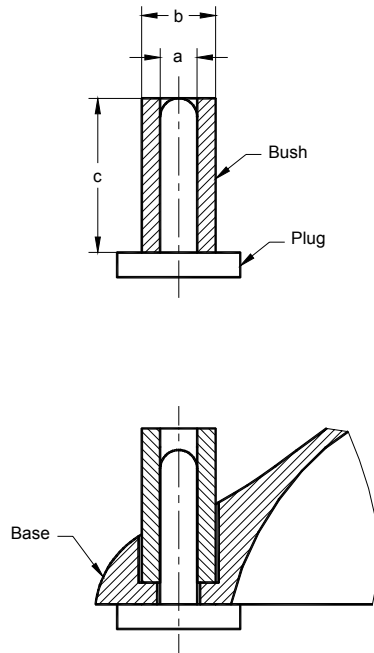

IEC 1076/08

Reference	Dimension	Tolerance	
		Manufacture	Wear
a	4,1	+0,03 -0,0	+0,0 -0,03
b	8,2	+0,03 -0,0	+0,0 -0,03
c	18	+0,1 -0,1	- -

Figure 3 – Gauge for holes for backplate lampholders screws (see 12.11)

The drawings are intended only to show typical parts of a lampholder and should not limit the design.

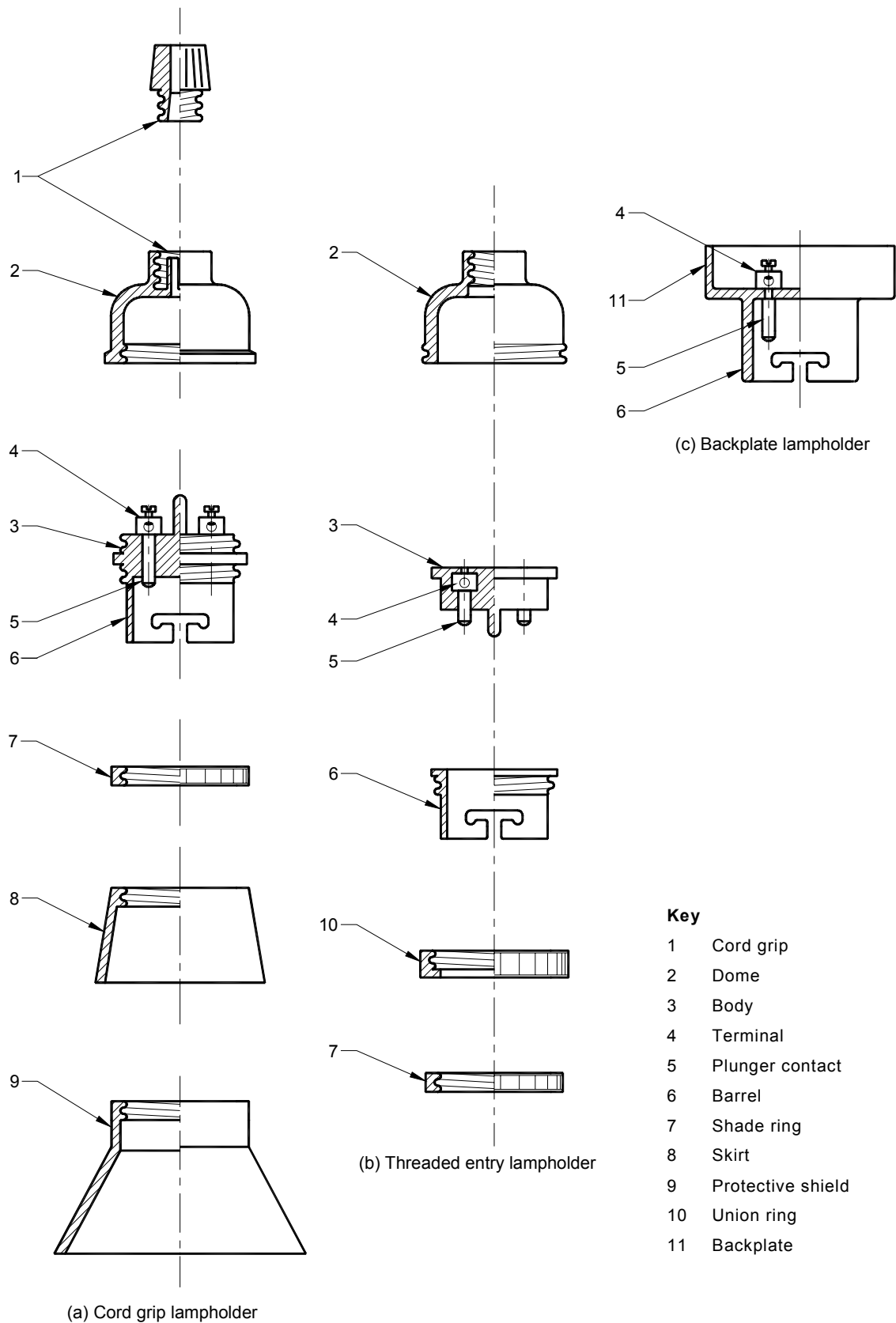
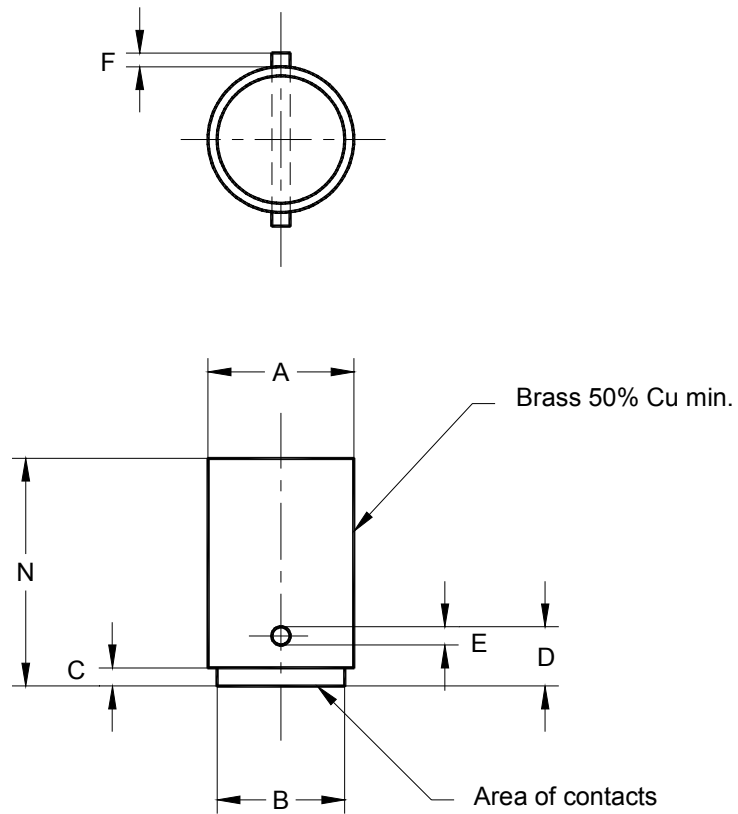

Figure 4 – Clarification of some of the definitions in Clause 2

Dimensions in millimetres



IEC 1078/08

Reference	Dimension	Tolerance
A	15,125	+0,05 -0,05
B	13	+0,05 -0,05
C	1,8	+0,05 -0,05
D	6	+0,05 -0,05
E	2	+0,05 -0,05
F	1	+0,05 -0,05
N	22	+0,5 -0,5

Figure 5 – Test cap B15d (see 18.3)

Dimensions in millimetres

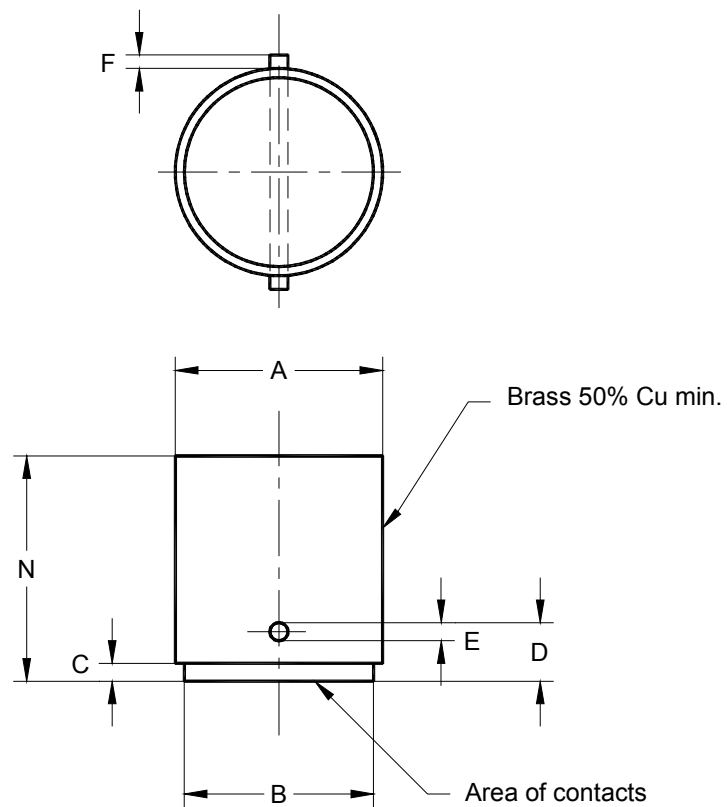

IEC 1079/08

Reference	Dimension	Tolerance
A	21,95	+0,05 -0,05
B	17	+0,05 -0,05
C	2,2	+0,05 -0,05
D	6	+0,05 -0,05
E	2	+0,05 -0,05
F	2,5	+0,05 -0,05
N	22	+0,5 -0,5

Figure 6 – Test cap B22d (see 18.3)

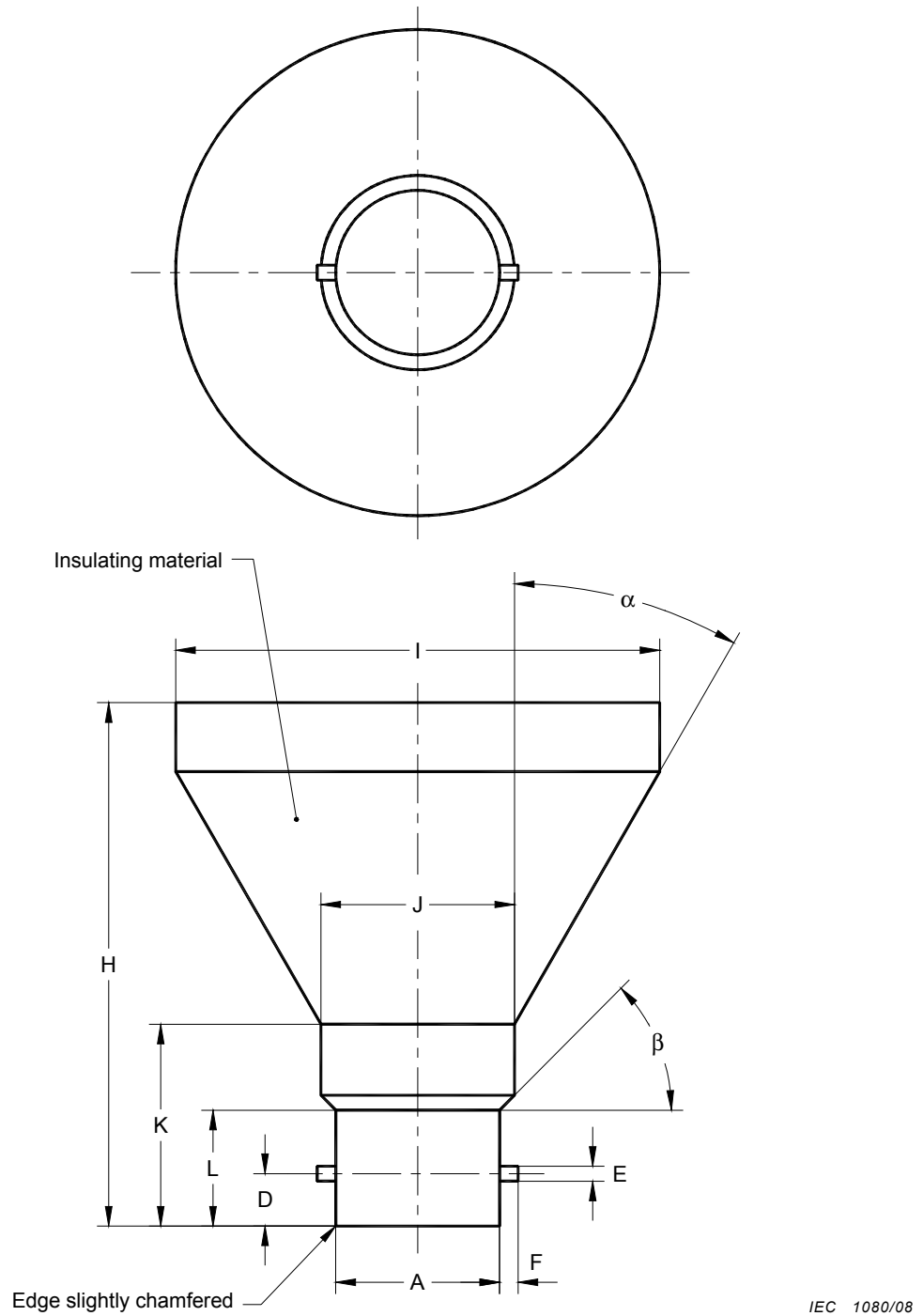

Reference	Dimension (mm)		Tolerance
	B15d	B22d	
A	15,25	22,15	+0,1 0
D	6,4	6,9	0 -0,1
E(1)	2,2	2,2	0 -0,1
F	1,1	2,7	0 -0,1
H	70	70	+0,1 -0,1
I	55	65	+0,1 0

Reference	Dimension (mm)		Tolerance
	B15d	B22d	
J	17,1	26,45	+0,1 0
K	26,0	27,0	0 -0,1
L	15,5	15,5	0 -0,1
α	30°	30°	+5' -5'
β	45°	45°	+5' -5'

Figure 7 – Testing device (see 9.1)

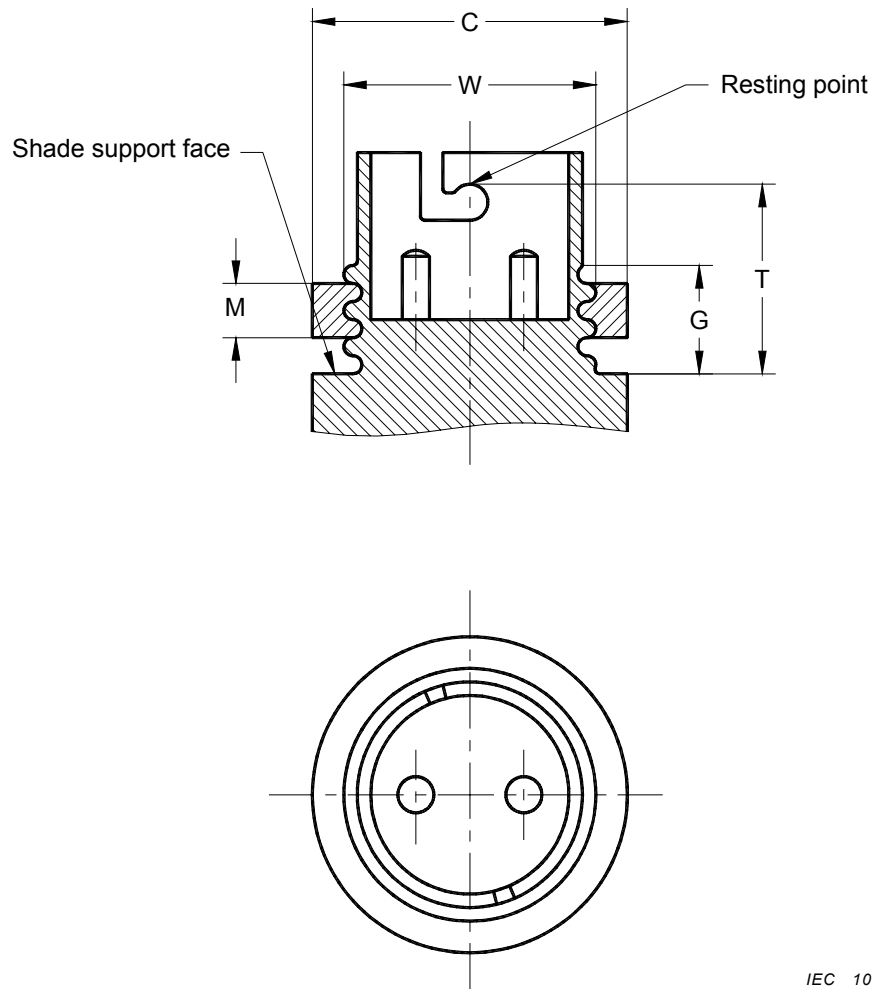

IEC 1081/08

Reference	Dimension (mm)			
	B15d		B22d	
	Min.	Max.	Min.	Max.
C	22,5	24,8	31,5	38,1
G	8,0	–	8,0	–
M (Note 1)	3,0	–	3,5	–
M (Note 2)	3,5	–	4,0	–
T (Note 3)	18,0	19,0	18,0	20,0
W (Note 4)	–	20,0	–	28,5

NOTE 1 These dimensions apply to metal shade carrier rings.

NOTE 2 These dimensions apply to plastic shade carrier rings.

NOTE 3 T is an optional dimension for lampholders where the position of the lamp is important in relation to the position of the luminaire or of a protective shield, when used.

NOTE 4 Dimension W applies only to lampholders designed to accept luminaires having a clearance hole of 29,0 mm minimum for B22d caps and 20,5 mm minimum for B15d caps and intended to be supported by a shade carrier device.

Figure 8 – Dimensions for shade support devices (see 8.1)

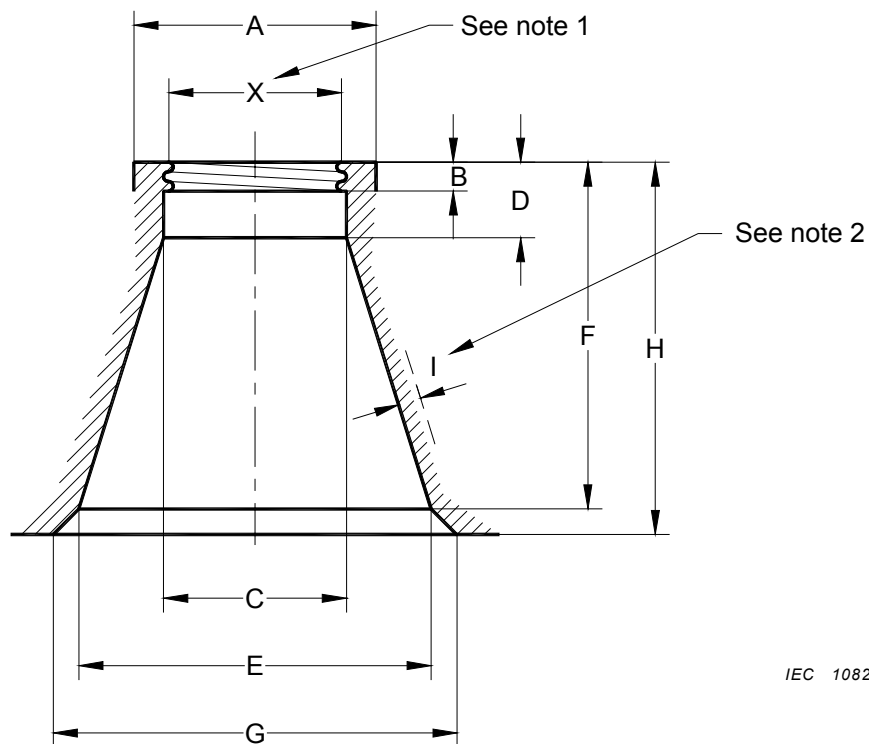
Dimensions in millimetres

IEC 1082/08

Dimension	Min.	Max.
A	31,75	–
B	4,75	–
C	29,0	–
D	–	13,5
E	45,0	–
F	38,0	–
G	48,0	49,5
H	39,0	40,0
I	1,5	–

Dimensions in millimetres

The drawing is intended only to indicate the dimensions that comply with the requirements of IEC 60064.

NOTE 1 There is to be no encroachment on the shaded profile except that the flared entry defined by dimensions E, F, G and H may be of any convenient profile provided that dimension E is complied with also within this section. Dimension X denotes a female thread or other means of attachment to a corresponding lampholder.

NOTE 2 There are to be at least three ventilation apertures in the wall of the shield, having an aggregate area not less than 115 mm², and the width of each aperture shall not exceed 6,5 mm. The 1,5 mm wall thickness may be reduced adjacent to these apertures.

Figure 9 – Dimensions for protective shields for B22d lampholders (see 9.1)

Dimensions in millimetres

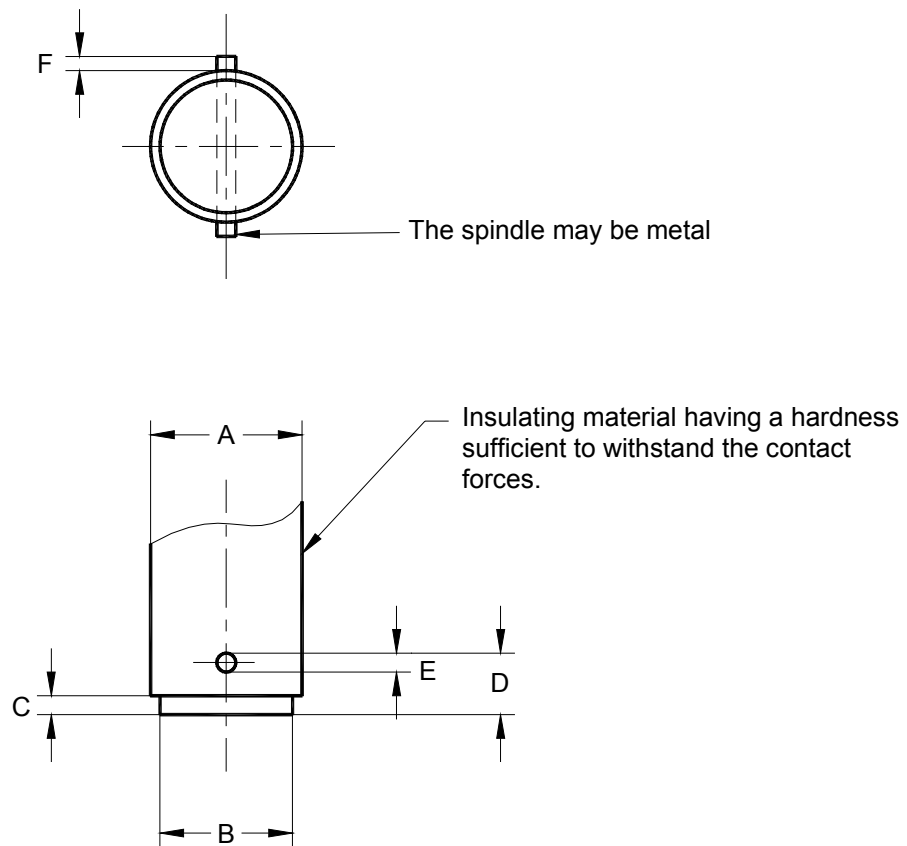

IEC 1083/08

NOTE This gauge is intended only to operate contact plungers during insulation resistance and high-voltage tests and not to prove lamp fit.

Reference	Dimension	Tolerance
A	15	+0,1 -0,1
B	13	+0,1 -0,1
C	1,8	+0,1 -0,1
D	7	+0,1 -0,1
E	2	+0,1 -0,1
F	1	+0,1 -0,1

Figure 10 – Test cap B15d (see 14.3)

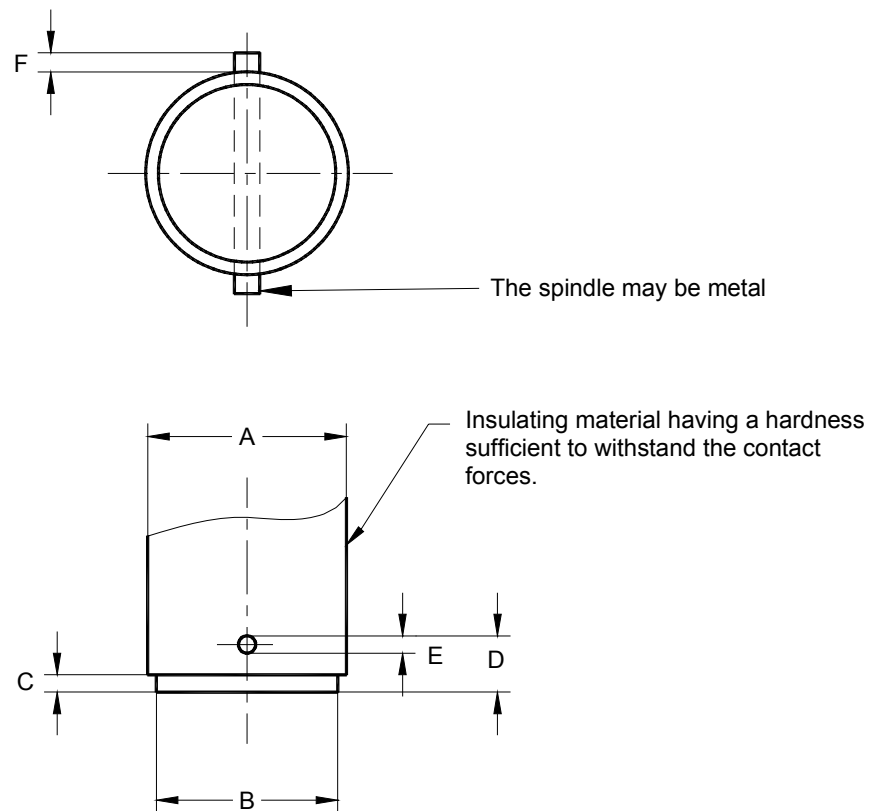

IEC 1084/08

NOTE This gauge is intended only to operate contact plungers during insulation resistance and high-voltage tests and not to prove lamp fit.

Reference	Dimension	Tolerance
A	22	+0,1 -0,1
B	17	+0,1 -0,1
C	2,2	+0,1 -0,1
D	7	+0,1 -0,1
E	2	+0,1 -0,1
F	2,5	+0,1 -0,1

Figure 11 – Test cap B22d (see 14.3)

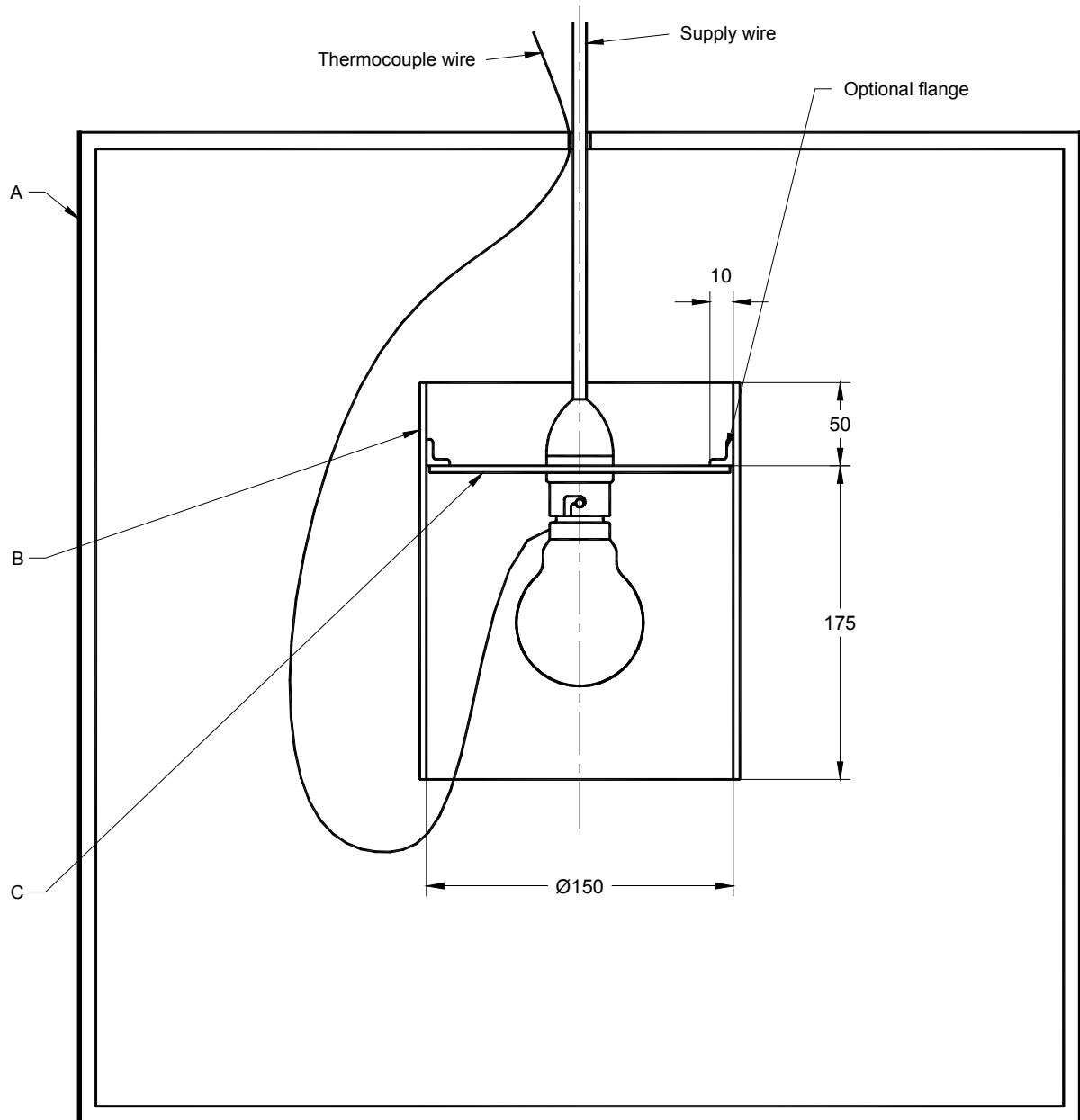

IEC 1085/08

Key

A - Test cabinet

Dimensions in millimetres

Material: 10 mm (nominal) plywood
 Internal finish: Two coats of matt paint
 Internal dimensions: 500 mm × 500 mm × 500 mm with a tolerance of ± 10 mm for each dimension.
 One wall to be removable to provide access.

Location: Minimum clearance from adjacent surfaces:
 - horizontally: 150 mm on all sides
 - vertically: 300 mm above; 500 mm below.

NOTE Test cabinets should not be subjected to heating or cooling from adjacent surfaces and extreme air movements should be avoided.

B and C - Test shade details

Material: 0,5 mm (nominal) thick sheet steel
 Finish: For B15d/T1, B22d/T1 and B22d/T2 lampholders:
 - two coats minimum of matt black paint outside and inside the shade.
 For B15d/T2 lampholders:
 - two coats minimum of black paint outside and above the internal shade barrier.

Below the internal shade barrier C, including the underside, bright plated or polished finish.

B - Shade dimensions: Open-ended tube, 150 mm internal diameter, 225 mm long with flange 50 mm from top which rests on shade barrier.

C - Shade barrier dimensions: 150 mm diameter disc with central hole (29,0 mm diameter for B22d lampholders; 20,5 mm diameter for B15d lampholders).

Figure 12 – Typical apparatus for the heating test (see 18.5)

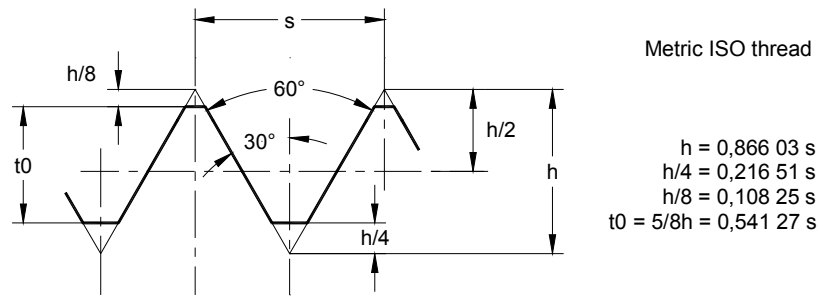

Basic profile *

IEC 1086/08

* The basic profile is the profile to which the deviations defining the limits of the external threads are applied.

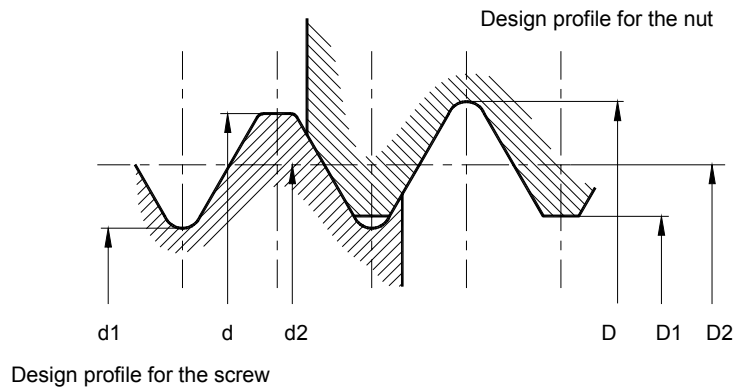

IEC 1087/08

Dimensions in millimetres

Designation	s	Screw					Nut				
		d		d2		d1	D	D2		D1	
		Max.	Min.	Max.	Min.	Max.	Min.	Max.	Min.	Max.	Min.
M10×1	1	10,000	9,800	9,350	9,238	8,917	10,000	9,462	9,350	9,117	8,917
M13×1	1	13,000	12,800	12,350	12,190	11,917	13,000	12,510	12,350	12,117	11,917

Figure 13 – Nipple thread for lampholders – Basic profile and design profile for the nut and for the screw

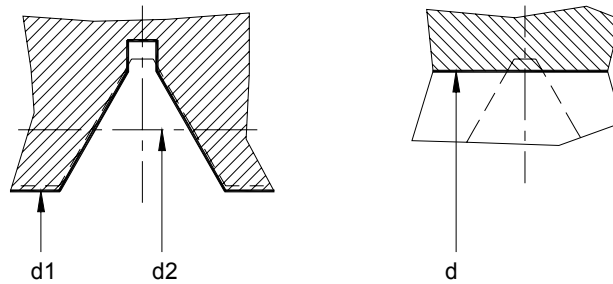

--- Basic profile (see figure 13)

 "Go" gauge

 "Not Go" gauge

IEC 1088/08

Dimensions in millimetres

Designation	a	d		d2		d1		Wear
			Tolerance		Tolerance		Tolerance	
M10×1	1	9,800	+0,004 -0,004	9,350	-0,012 -0,020	8,917	+0,004 -0,004	0,012
M13×1	1	12,800	+0,004 -0,004	12,350	-0,012 -0,020	11,917	+0,004 -0,004	0,012

Figure 14a – Gauges for the screw

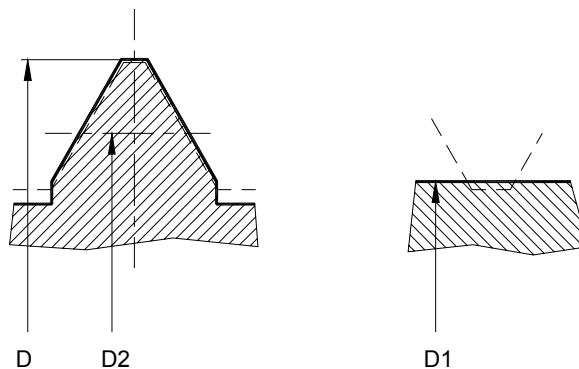

--- Basic profile (see figure 13)

 "Go" gauge

 "Not Go" gauge

IEC 1089/08

Dimensions in millimetres

Designation	a	D		D2		D1		Wear
			Tolerance		Tolerance		Tolerance	
M10×1	1	10,000	+0,004 -0,004	9,350	+0,012 +0,020	9,117	+0,004 -0,004	0,012
M13×1	1	13,000	+0,004 -0,004	12,350	+0,012 +0,020	12,117	+0,004 -0,004	0,012

Figure 14b – Gauges for the nut

Figure 14 – Gauges for metric ISO thread for nipples

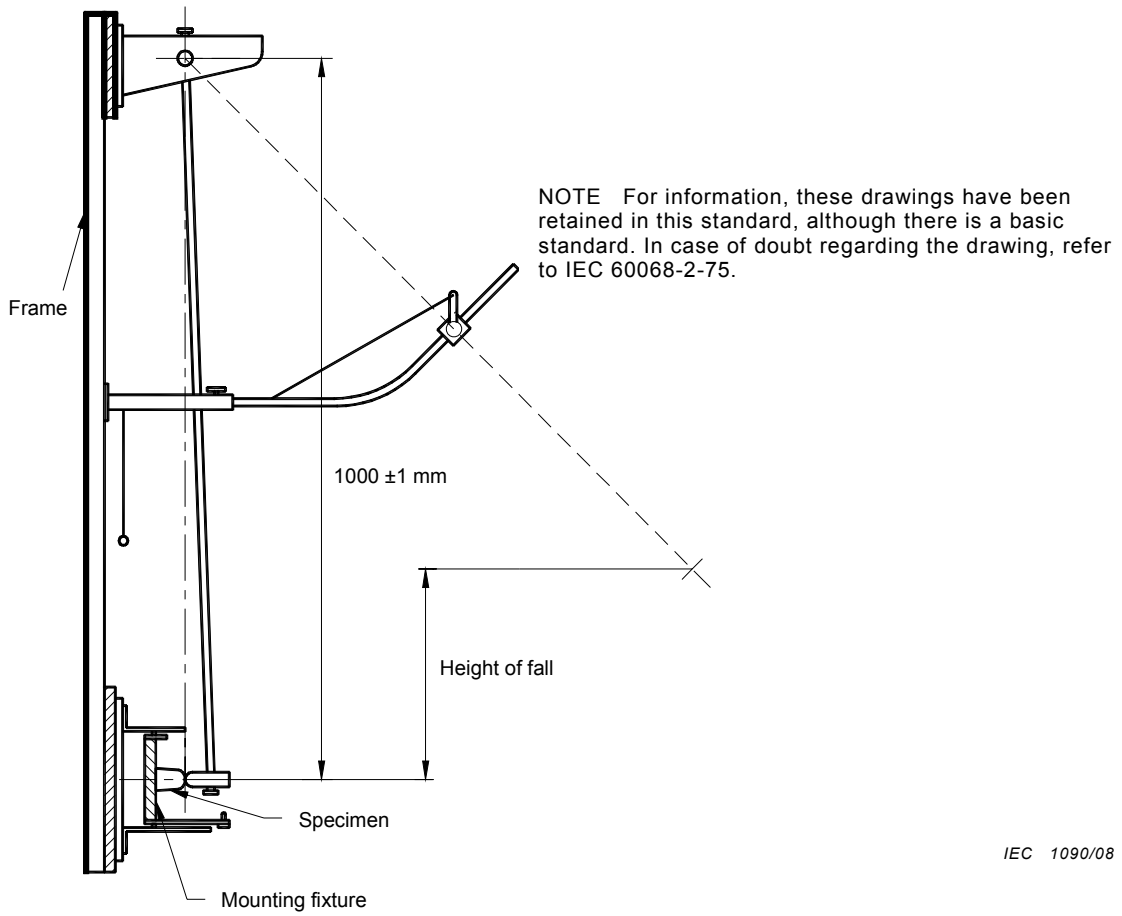

Figure 15 – Impact-test apparatus

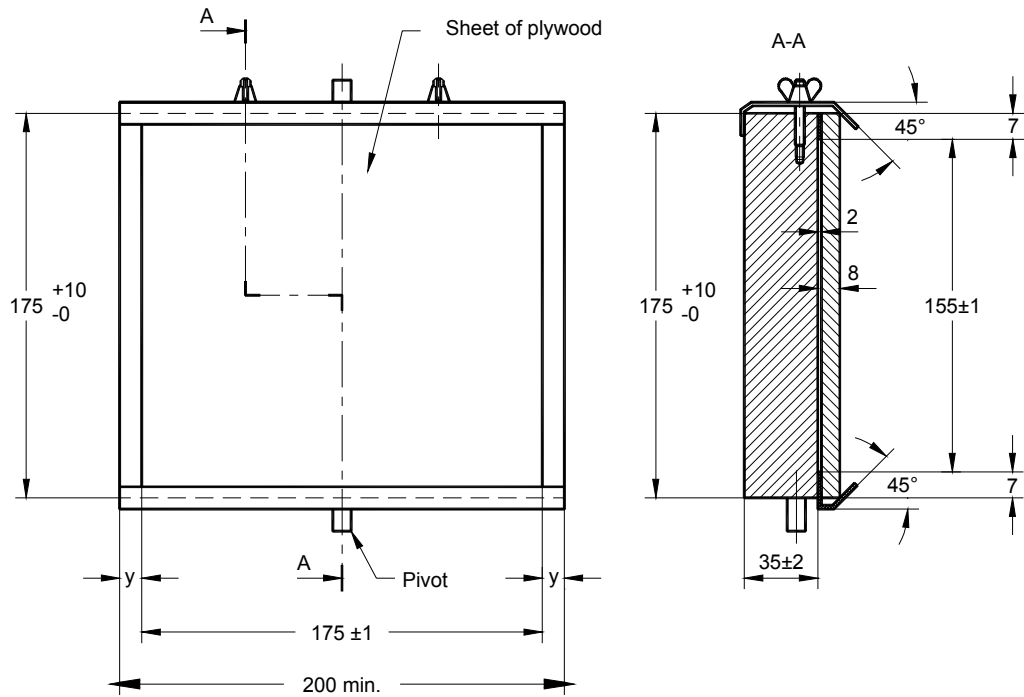
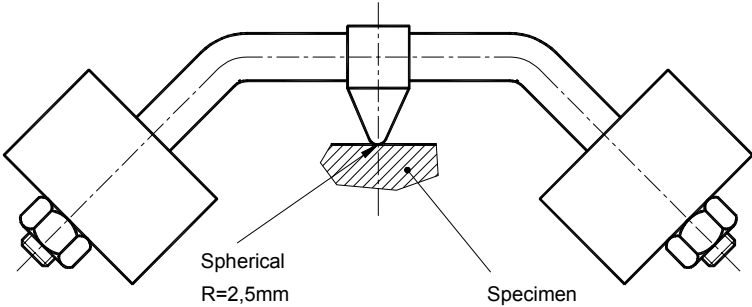
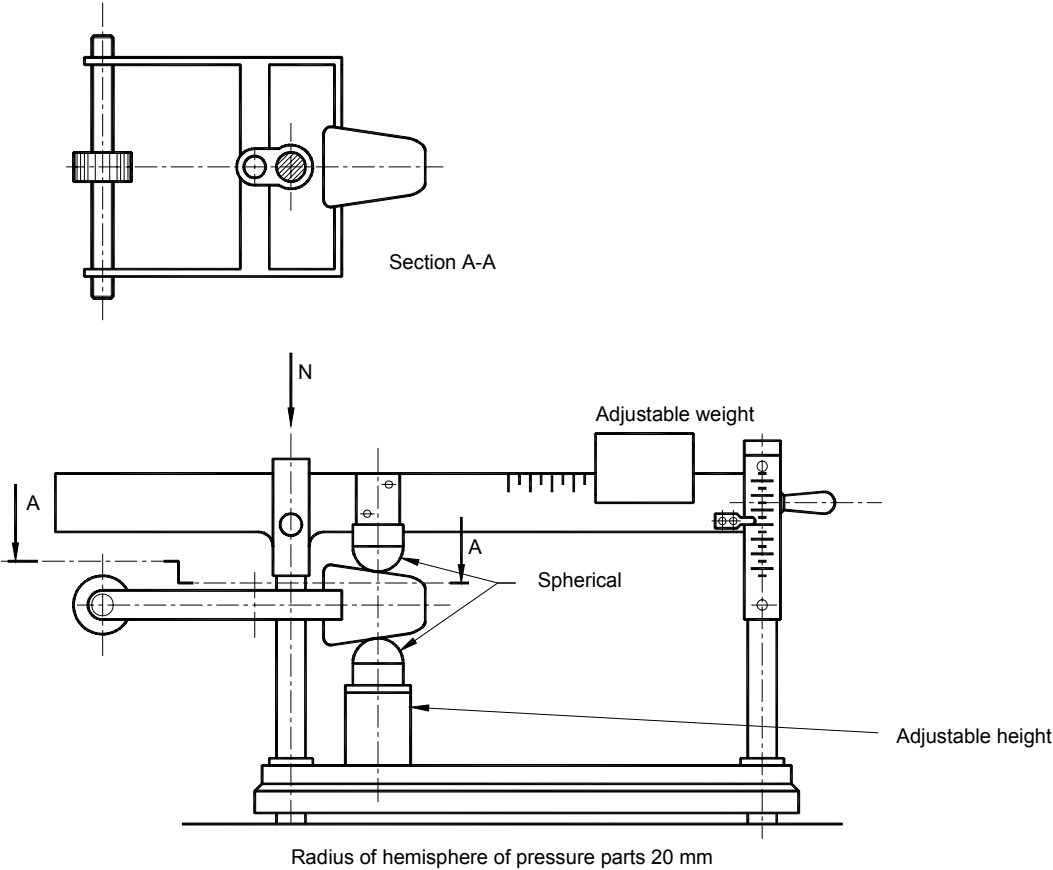

Figure 16 – Mounting support



IEC 1092/08

Figure 17 – Ball-pressure test apparatus



IEC 1093/08

Figure 18 – Pressure apparatus

Annex A (normative)

Season cracking/corrosion test

NOTE In the interest of environmental protection, the following requirements relating to test solution, volume and volume of vessel may be modified at the discretion of the test laboratory.

In this event, the test vessel should retain a volume in the range 500 to 1 000 times larger than the volume of the sample and the volume of test solution should be such that the ratio of vessel volume to solution volume is in the range of 20:1 to 10:1. In case of doubt, however, the conditions of Clause A.1 apply.

A.1 Test cabinet

Closeable glass vessels shall be used for the test. These may, for example, be desiccator vessels or simple glass troughs with ground rim and lid. The vessels' volume shall be at least 10 l. A certain ratio of test space to volume of test solution shall be maintained (20:1 to 10:1).

A.2 Test solution

Preparation of 1 l of solution:

Dissolve 107 g ammonium chloride (reagent grade NH_4Cl) in about 0,75 l of distilled or fully demineralized water and add as much of 30 % sodium hydroxide solution (prepared from reagent grade NaOH and distilled or fully demineralized water) as is necessary to reach a pH value of 10 at 22 °C. For other temperatures, adjust this solution to the corresponding pH values specified in Table A.1.

Table A.1 – Ph adjustment

Temperature °C	Test solution pH
22 ± 1	10,0 ± 0,1
25 ± 1	9,9 ± 0,1
27 ± 1	9,8 ± 0,1
30 ± 1	9,7 ± 0,1

After the pH adjustment, make up to 1 l with distilled or fully demineralized water. This does not change the pH value any further.

Keep the temperature constant in any event to within ± 1 °C during the pH adjustment, and carry out the pH measurement using an instrument which permits an adjustment of the pH value to within ± 0,02.

The test solutions may be used over a prolonged period, but the pH value, which represents a measure of the ammonia concentration in the vapour atmosphere, shall be checked at least every three weeks and adjusted if necessary.

A.3 Test procedure

Introduce, preferably suspended, the specimens in the test cabinet in such a way that the ammonia vapour can take effect unhindered. The specimens shall not dip into the test

solution nor touch each other. Supports or suspension devices shall be made of materials which are not susceptible to attack by ammonia vapour, e.g. glass or porcelain.

Testing shall be carried out at a constant temperature of (30 ± 1) °C to exclude visible condensed water formation caused by temperature fluctuations, which could severely falsify the test result.

Prior to testing, the test cabinet containing the test solution shall be brought to a temperature of (30 ± 1) °C. The test cabinet shall subsequently be filled as quickly as possible with the specimens pre-heated to 30 °C and closed.

This moment is to be considered the beginning of the test.

Bibliography

IEC 60061-4, *Lamp caps and holders together with gauges for the control of interchangeability and safety – Part 4: Guidelines and general information*

IEC 60238, *Edison screw lampholders*

IEC 61058-1, *Switches for appliances – Part 1: General requirements*

This page deliberately left blank

British Standards Institution (BSI)

BSI is the independent national body responsible for preparing British Standards. It presents the UK view on standards in Europe and at the international level.

It is incorporated by Royal Charter.

Revisions

British Standards are updated by amendment or revision. Users of British Standards should make sure that they possess the latest amendments or editions.

It is the constant aim of BSI to improve the quality of our products and services. We would be grateful if anyone finding an inaccuracy or ambiguity while using this British Standard would inform the Secretary of the technical committee responsible, the identity of which can be found on the inside front cover.

Tel: +44 (0)20 8996 9000 Fax: +44 (0)20 8996 7400

BSI offers members an individual updating service called PLUS which ensures that subscribers automatically receive the latest editions of standards.

Buying standards

Orders for all BSI, international and foreign standards publications should be addressed to BSI Customer Services.

Tel: +44 (0)20 8996 9001 Fax: +44 (0)20 8996 7001
Email: orders@bsigroup.com

You may also buy directly using a debit/credit card from the BSI Shop on the website www.bsigroup.com/shop

In response to orders for international standards, it is BSI policy to supply the BSI implementation of those that have been published as British Standards, unless otherwise requested.

Information on standards

BSI provides a wide range of information on national, European and international standards through its Library.

Various BSI electronic information services are also available which give details on all its products and services. Contact the Information Centre.

Tel: +44 (0)20 8996 7111

Fax: +44 (0)20 8996 7048 Email: info@bsigroup.com

Subscribing members of BSI are kept up to date with standards developments and receive substantial discounts on the purchase price of standards. For details of these and other benefits contact Membership Administration.

Tel: +44 (0)20 8996 7002 Fax: +44 (0)20 8996 7001

Email: membership@bsigroup.com

Information regarding online access to British Standards via British Standards Online can be found at www.bsigroup.com/BSOL

Further information about BSI is available on the BSI website at www.bsigroup.com

Copyright

Copyright subsists in all BSI publications. BSI also holds the copyright, in the UK, of the publications of the international standardization bodies. Except as permitted under the Copyright, Designs and Patents Act 1988 no extract may be reproduced, stored in a retrieval system or transmitted in any form or by any means – electronic, photocopying, recording or otherwise – without prior written permission from BSI.

This does not preclude the free use, in the course of implementing the standard of necessary details such as symbols, and size, type or grade designations. If these details are to be used for any other purpose than implementation then the prior written permission of BSI must be obtained. Details and advice can be obtained from the Copyright & Licensing Manager.

Tel: +44 (0)20 8996 7070 Email: copyright@bsigroup.com

BSI Group Headquarters

389 Chiswick High Road London W4 4AL UK

Tel +44 (0)20 8996 9001

Fax +44 (0)20 8996 7001

www.bsigroup.com/standards

raising standards worldwide™

BSI
British Standards