

BS EN 61158-1:2014



BSI Standards Publication

# Industrial communication networks — Fieldbus specifications

Part 1: Overview and guidance for the IEC 61158 and IEC 61784 series

**bsi.**

...making excellence a habit.™

**National foreword**

This British Standard is the UK implementation of EN 61158-1:2014. It is identical to IEC 61158-1:2014. It supersedes PD CLC/TR 61158-1:2010 which is withdrawn.

The UK participation in its preparation was entrusted to Technical Committee AMT/7, Industrial communications: process measurement and control, including fieldbus.

A list of organizations represented on this committee can be obtained on request to its secretary.

This publication does not purport to include all the necessary provisions of a contract. Users are responsible for its correct application.

© The British Standards Institution 2014.

Published by BSI Standards Limited 2014

ISBN 978 0 580 79254 0

ICS 25.040.40; 33.040; 35.100.05

**Compliance with a British Standard cannot confer immunity from legal obligations.**

This British Standard was published under the authority of the Standards Policy and Strategy Committee on 31 October 2014.

**Amendments/corrigenda issued since publication**

<b>Date</b>	<b>Text affected</b>
-------------	----------------------

---

EUROPEAN STANDARD

**EN 61158-1**

NORME EUROPÉENNE

EUROPÄISCHE NORM

September 2014

ICS 25.040.40; 33.040; 35.100.05

Supersedes CLC/TR 61158-1:2010

English Version

**Industrial communication networks - Fieldbus specifications -  
Part 1: Overview and guidance for the IEC 61158 and IEC 61784  
series  
(IEC 61158-1:2014)**

Réseaux de communication industriels - Spécifications des  
bus de terrain - Partie 1: Présentation et lignes directrices  
des séries CEI 61158 et CEI 61784  
(CEI 61158-1:2014)

Industrielle Kommunikationsnetze - Feldbusse -  
Teil 1: Überblick und Leitfaden zu den Normen der Reihe  
IEC 61158 und IEC 61784  
(IEC 61158-1:2014)

This European Standard was approved by CENELEC on 2014-06-27. CENELEC members are bound to comply with the CEN/CENELEC Internal Regulations which stipulate the conditions for giving this European Standard the status of a national standard without any alteration.

Up-to-date lists and bibliographical references concerning such national standards may be obtained on application to the CEN-CENELEC Management Centre or to any CENELEC member.

This European Standard exists in three official versions (English, French, German). A version in any other language made by translation under the responsibility of a CENELEC member into its own language and notified to the CEN-CENELEC Management Centre has the same status as the official versions.

CENELEC members are the national electrotechnical committees of Austria, Belgium, Bulgaria, Croatia, Cyprus, the Czech Republic, Denmark, Estonia, Finland, Former Yugoslav Republic of Macedonia, France, Germany, Greece, Hungary, Iceland, Ireland, Italy, Latvia, Lithuania, Luxembourg, Malta, the Netherlands, Norway, Poland, Portugal, Romania, Slovakia, Slovenia, Spain, Sweden, Switzerland, Turkey and the United Kingdom.



European Committee for Electrotechnical Standardization  
Comité Européen de Normalisation Electrotechnique  
Europäisches Komitee für Elektrotechnische Normung

**CEN-CENELEC Management Centre: Avenue Marnix 17, B-1000 Brussels**

## Foreword

The text of document 65C/757/FDIS, future edition 1 of IEC 61158-1, prepared by SC 65C "Industrial networks" of IEC/TC 65 "Industrial-process measurement, control and automation" was submitted to the IEC-CENELEC parallel vote and approved by CENELEC as EN 61158-1:2014.

The following dates are fixed:

- latest date by which the document has to be implemented at national level by publication of an identical national standard or by endorsement (dop) 2015-03-27
- latest date by which the national standards conflicting with the document have to be withdrawn (dow) 2017-06-27

This document supersedes CLC/TR 61158-1:2010.

Attention is drawn to the possibility that some of the elements of this document may be the subject of patent rights. CENELEC [and/or CEN] shall not be held responsible for identifying any or all such patent rights.

This document has been prepared under a mandate given to CENELEC by the European Commission and the European Free Trade Association.

## Endorsement notice

The text of the International Standard IEC 61158-1:2014 was approved by CENELEC as a European Standard without any modification.

In the official version, for Bibliography, the following notes have to be added for the standards indicated:

IEC 60793-2-30:2012	NOTE	Harmonized as EN 60793-2-30:2013 (not modified).
IEC 60793-2-40:2009	NOTE	Harmonized as EN 60793-2-40:2011 (not modified).
IEC 61000-6-2	NOTE	Harmonized as EN 61000-6-2.
IEC 61131-2	NOTE	Harmonized as EN 61131-2.
IEC 61158 Series	NOTE	Harmonized as EN 61158 Series (not modified).
IEC 61158-2:2014	NOTE	Harmonized as EN 61158-2 <sup>1)</sup> (not modified).
IEC 61158-3-1:2014	NOTE	Harmonized as EN 61158-3-1 <sup>1)</sup> (not modified).
IEC 61158-3-2:2014	NOTE	Harmonized as EN 61158-3-2 <sup>1)</sup> (not modified).
IEC 61158-3-3:2014	NOTE	Harmonized as EN 61158-3-3 <sup>1)</sup> (not modified).
IEC 61158-3-4:2014	NOTE	Harmonized as EN 61158-3-4 <sup>1)</sup> (not modified).
IEC 61158-3-7:2007	NOTE	Harmonized as EN 61158-3-7:2008 (not modified).
IEC 61158-3-8:2007	NOTE	Harmonized as EN 61158-3-8:2008 (not modified).
IEC 61158-3-11:2007	NOTE	Harmonized as EN 61158-3-11:2008 (not modified).
IEC 61158-3-12:2014	NOTE	Harmonized as EN 61158-3-12 <sup>1)</sup> (not modified).
IEC 61158-3-13:2014	NOTE	Harmonized as EN 61158-3-13 <sup>1)</sup> (not modified).
IEC 61158-3-14:2014	NOTE	Harmonized as EN 61158-3-14 <sup>1)</sup> (not modified).
IEC 61158-3-16:2007	NOTE	Harmonized as EN 61158-3-16:2008 (not modified).

---

<sup>1)</sup> To be published.

IEC 61158-3-17:2007	NOTE	Harmonized as EN 61158-3-17:2008 (not modified).
IEC 61158-3-18:2007	NOTE	Harmonized as EN 61158-3-18:2008 (not modified).
IEC 61158-3-19:2014	NOTE	Harmonized as EN 61158-3-19 <sup>1)</sup> (not modified).
IEC 61158-3-20:2014	NOTE	Harmonized as EN 61158-3-20 <sup>1)</sup> (not modified).
IEC 61158-3-21:2010	NOTE	Harmonized as EN 61158-3-21:2012 (not modified).
IEC 61158-3-22:2014	NOTE	Harmonized as EN 61158-3-22 <sup>1)</sup> (not modified).
IEC 61158-3-24:2014	NOTE	Harmonized as EN 61158-3-24 <sup>1)</sup> (not modified).
IEC 61158-4-1:2014	NOTE	Harmonized as EN 61158-4-1 <sup>1)</sup> (not modified).
IEC 61158-4-2:2014	NOTE	Harmonized as EN 61158-4-2 <sup>1)</sup> (not modified).
IEC 61158-4-3:2014	NOTE	Harmonized as EN 61158-4-3 <sup>1)</sup> (not modified).
IEC 61158-4-4:2014	NOTE	Harmonized as EN 61158-4-4 <sup>1)</sup> (not modified).
IEC 61158-4-7:2007	NOTE	Harmonized as EN 61158-4-7:2008 (not modified).
IEC 61158-4-8:2007	NOTE	Harmonized as EN 61158-4-8:2008 (not modified).
IEC 61158-4-11:2014	NOTE	Harmonized as EN 61158-4-11 <sup>1)</sup> (not modified).
IEC 61158-4-12:2014	NOTE	Harmonized as EN 61158-4-12 <sup>1)</sup> (not modified).
IEC 61158-4-13:2014	NOTE	Harmonized as EN 61158-4-13 <sup>1)</sup> (not modified).
IEC 61158-4-14:2014	NOTE	Harmonized as EN 61158-4-14 <sup>1)</sup> (not modified).
IEC 61158-4-16:2007	NOTE	Harmonized as EN 61158-4-16:2008 (not modified).
IEC 61158-4-17:2007	NOTE	Harmonized as EN 61158-4-17:2008 (not modified).
IEC 61158-4-18:2010	NOTE	Harmonized as EN 61158-4-18:2012 (not modified).
IEC 61158-4-19:2014	NOTE	Harmonized as EN 61158-4-19 <sup>1)</sup> (not modified).
IEC 61158-4-20:2014	NOTE	Harmonized as EN 61158-4-20 <sup>1)</sup> (not modified).
IEC 61158-4-21:2010	NOTE	Harmonized as EN 61158-4-21:2012 (not modified).
IEC 61158-4-22:2014	NOTE	Harmonized as EN 61158-4-22 <sup>1)</sup> (not modified).
IEC 61158-4-24:2014	NOTE	Harmonized as EN 61158-4-24 <sup>1)</sup> (not modified).
IEC 61158-5-2:2014	NOTE	Harmonized as EN 61158-5-2 <sup>1)</sup> (not modified).
IEC 61158-5-3:2014	NOTE	Harmonized as EN 61158-5-3 <sup>1)</sup> (not modified).
IEC 61158-5-4:2014	NOTE	Harmonized as EN 61158-5-4 <sup>1)</sup> (not modified).
IEC 61158-5-5:2014	NOTE	Harmonized as EN 61158-5-5 <sup>1)</sup> (not modified).
IEC 61158-5-7:2007	NOTE	Harmonized as EN 61158-5-7:2008 (not modified).
IEC 61158-5-8:2007	NOTE	Harmonized as EN 61158-5-8:2008 (not modified).
IEC 61158-5-9:2014	NOTE	Harmonized as EN 61158-5-9 <sup>1)</sup> (not modified).
IEC 61158-5-10:2014	NOTE	Harmonized as EN 61158-5-10 <sup>1)</sup> (not modified).
IEC 61158-5-11:2007	NOTE	Harmonized as EN 61158-5-11:2008 (not modified).
IEC 61158-5-12:2014	NOTE	Harmonized as EN 61158-5-12 <sup>1)</sup> (not modified).
IEC 61158-5-13:2014	NOTE	Harmonized as EN 61158-5-13 <sup>1)</sup> (not modified).
IEC 61158-5-14:2014	NOTE	Harmonized as EN 61158-5-14 <sup>1)</sup> (not modified).
IEC 61158-5-15:2010	NOTE	Harmonized as EN 61158-5-15:2012 (not modified).
IEC 61158-5-16:2007	NOTE	Harmonized as EN 61158-5-16:2008 (not modified).
IEC 61158-5-17:2007	NOTE	Harmonized as EN 61158-5-17:2008 (not modified).
IEC 61158-5-18:2010	NOTE	Harmonized as EN 61158-5-18:2012 (not modified).

---

<sup>1)</sup> To be published.

IEC 61158-5-19:2014	NOTE	Harmonized as EN 61158-5-19 <sup>1)</sup> (not modified).
IEC 61158-5-20:2014	NOTE	Harmonized as EN 61158-5-20 <sup>1)</sup> (not modified).
IEC 61158-5-21:2010	NOTE	Harmonized as EN 61158-5-21:2012 (not modified).
IEC 61158-5-22:2010	NOTE	Harmonized as EN 61158-5-22:2012 (not modified).
IEC 61158-5-23:2014	NOTE	Harmonized as EN 61158-5-23 <sup>1)</sup> (not modified).
IEC 61158-5-24:2014	NOTE	Harmonized as EN 61158-5-24 <sup>1)</sup> (not modified).
IEC 61158-6-2:2014	NOTE	Harmonized as EN 61158-6-2 <sup>1)</sup> (not modified).
IEC 61158-6-3:2014	NOTE	Harmonized as EN 61158-6-3 <sup>1)</sup> (not modified).
IEC 61158-6-4:2014	NOTE	Harmonized as EN 61158-6-4 <sup>1)</sup> (not modified).
IEC 61158-6-5:2014	NOTE	Harmonized as EN 61158-6-5 <sup>1)</sup> (not modified).
IEC 61158-6-7:2007	NOTE	Harmonized as EN 61158-6-7:2008 (not modified).
IEC 61158-6-8:2007	NOTE	Harmonized as EN 61158-6-8:2008 (not modified).
IEC 61158-6-9:2014	NOTE	Harmonized as EN 61158-6-9 <sup>1)</sup> (not modified).
IEC 61158-6-10:2014	NOTE	Harmonized as EN 61158-6-10 <sup>1)</sup> (not modified).
IEC 61158-6-11:2007	NOTE	Harmonized as EN 61158-6-11:2008 (not modified).
IEC 61158-6-12:2014	NOTE	Harmonized as EN 61158-6-12 <sup>1)</sup> (not modified).
IEC 61158-6-13:2014	NOTE	Harmonized as EN 61158-6-13 <sup>1)</sup> (not modified).
IEC 61158-6-14:2014	NOTE	Harmonized as EN 61158-6-14 <sup>1)</sup> (not modified).
IEC 61158-6-15:2010	NOTE	Harmonized as EN 61158-6-15:2012 (not modified).
IEC 61158-6-16:2007	NOTE	Harmonized as EN 61158-6-16:2008 (not modified).
IEC 61158-6-17:2007	NOTE	Harmonized as EN 61158-6-17:2008 (not modified).
IEC 61158-6-18:2010	NOTE	Harmonized as EN 61158-6-18:2012 (not modified).
IEC 61158-6-19:2014	NOTE	Harmonized as EN 61158-6-19 <sup>1)</sup> (not modified).
IEC 61158-6-20:2014	NOTE	Harmonized as EN 61158-6-20 <sup>1)</sup> (not modified).
IEC 61158-6-21:2010	NOTE	Harmonized as EN 61158-6-21:2012 (not modified).
IEC 61158-6-22:2014	NOTE	Harmonized as EN 61158-6-22 <sup>1)</sup> (not modified).
IEC 61158-6-23:2014	NOTE	Harmonized as EN 61158-6-23 <sup>1)</sup> (not modified).
IEC 61158-6-24:2014	NOTE	Harmonized as EN 61158-6-24 <sup>1)</sup> (not modified).
IEC 61326 Series	NOTE	Harmonized as EN 61326 Series (not modified).
IEC 61508 Series	NOTE	Harmonized as EN 61508 Series (not modified).
IEC 61784-1:2014	NOTE	Harmonized as EN 61784-1 <sup>1)</sup> (not modified).
IEC 61784-2:2014	NOTE	Harmonized as EN 61784-2 <sup>1)</sup> (not modified).
IEC 61784-3:2010	NOTE	Harmonized as EN 61784-3:2010 (not modified).
IEC 61784-3-1:2010	NOTE	Harmonized as EN 61784-3-1:2010 (not modified).
IEC 61784-3-2:2010	NOTE	Harmonized as EN 61784-3-2:2010 (not modified).
IEC 61784-3-3:2010	NOTE	Harmonized as EN 61784-3-3:2010 (not modified).
IEC 61784-3-6:2010	NOTE	Harmonized as EN 61784-3-6:2010 (not modified).
IEC 61784-3-8:2010	NOTE	Harmonized as EN 61784-3-8:2010 (not modified).
IEC 61784-3-12:2010	NOTE	Harmonized as EN 61784-3-12:2010 (not modified).
IEC 61784-3-13:2010	NOTE	Harmonized as EN 61784-3-13:2010 (not modified).
IEC 61784-3-14:2010	NOTE	Harmonized as EN 61784-3-14:2010 (not modified).

---

<sup>1)</sup> To be published.

IEC 61784-3-18:2011	NOTE	Harmonized as EN 61784-3-18:2011 (not modified).
IEC 61784-5-1:2013	NOTE	Harmonized as EN 61784-5-1:2013 (not modified).
IEC 61784-5-2:2013	NOTE	Harmonized as EN 61784-5-2:2013 (not modified).
IEC 61784-5-3:2013	NOTE	Harmonized as EN 61784-5-3:2013 (not modified).
IEC 61784-5-4:2010	NOTE	Harmonized as EN 61784-5-4:2012 (not modified).
IEC 61784-5-6:2013	NOTE	Harmonized as EN 61784-5-6:2013 (not modified).
IEC 61784-5-8:2013	NOTE	Harmonized as EN 61784-5-8:2013 (not modified).
IEC 61784-5-10:2010	NOTE	Harmonized as EN 61784-5-10:2012 (not modified).
IEC 61784-5-11:2013	NOTE	Harmonized as EN 61784-5-11:2013 (not modified).
IEC 61784-5-12:2010	NOTE	Harmonized as EN 61784-5-12:2012 (not modified).
IEC 61784-5-13:2013	NOTE	Harmonized as EN 61784-5-13:2013 (not modified).
IEC 61784-5-14:2013	NOTE	Harmonized as EN 61784-5-14:2013 (not modified).
IEC 61784-5-15:2010	NOTE	Harmonized as EN 61784-5-15:2012 (not modified).
IEC 61784-5-16:2013	NOTE	Harmonized as EN 61784-5-16:2013 (not modified).
IEC 61784-5-17:2013	NOTE	Harmonized as EN 61784-5-17:2013 (not modified).
IEC 61784-5-18:2013	NOTE	Harmonized as EN 61784-5-18:2013 (not modified).
IEC 61784-5-19:2013	NOTE	Harmonized as EN 61784-5-19:2013 (not modified).
IEC 61804 Series	NOTE	Harmonized as EN 61804 Series (not modified).
IEC 61918:2013	NOTE	Harmonized as EN 61918:2013 (modified).
IEC 62439 Series	NOTE	Harmonized as EN 62439 Series (not modified).
IEC 62453 Series	NOTE	Harmonized as EN 62453 Series (not modified).
IEC 62591	NOTE	Harmonized as EN 62591.
IEC 62657-2	NOTE	Harmonized as EN 62657-2 <sup>2)</sup> .
IEC 62734	NOTE	Harmonized as EN 62734 <sup>2)</sup> .
IEC/TR 62685:2010	NOTE	Harmonized as CLC/TR 62685:2011 (not modified).

---

<sup>2)</sup> At draft stage.

## CONTENTS

1	Scope .....	6
2	Normative references .....	6
3	Terms, definitions and abbreviated terms .....	6
3.1	Terms and definitions .....	6
3.2	Abbreviations .....	7
4	Guidelines for implementers and users .....	7
4.1	Background and purpose .....	7
4.2	Supported options .....	8
4.3	Benefits from using a common and formal style .....	8
5	Concept of the IEC 61158 series .....	9
6	Mapping onto the OSI Basic Reference Model .....	11
6.1	Overview .....	11
6.2	Physical layer service and protocol .....	11
6.3	Data-link layer service .....	12
6.4	Data-link layer protocol .....	13
6.5	Application layer service .....	13
6.6	Application layer protocol .....	14
7	Structure of IEC 61158 and IEC 61784 series .....	15
7.1	The IEC 61158 physical layer .....	15
7.2	The IEC 61158 data-link layer .....	15
7.3	The IEC 61158 application layer .....	16
7.4	IEC 61784-1 and IEC 61784-2 fieldbus profiles .....	16
7.5	IEC 61784-3 functional safety communication profiles .....	20
7.6	IEC 61784-5 installation profiles .....	22
7.7	Communication profiles for wireless communication networks .....	24
8	Brief summary of the characteristics of service and protocol for each fieldbus type .....	25
8.1	Summary of the physical layer service and protocol characteristics .....	25
8.2	Summary of data-link layer service characteristics .....	27
8.3	Summary of data-link layer protocol characteristics .....	29
8.4	Summary of application layer service characteristics .....	30
8.5	Summary of application layer protocol characteristics .....	32
9	Application layer service description concepts .....	34
9.1	Overview .....	34
9.2	Architectural relationships .....	34
9.3	Fieldbus application layer structure .....	36
9.4	Fieldbus application layer naming and addressing .....	48
9.5	Architecture summary .....	49
9.6	Notional FAL service procedures .....	50
9.7	Common FAL attributes .....	51
9.8	Common FAL service parameters .....	52
9.9	APDU size .....	53
10	Data type ASE .....	53
10.1	Overview .....	53
10.2	Formal definition of data type objects .....	55



11	Fieldbus system requirements .....	57
11.1	General .....	57
11.2	Industrial control network .....	57
11.3	Communication between industrial control networks and other networks .....	58
11.4	Quality of service features of an industrial control network .....	58
11.5	Special requirements for wireless networks .....	59
Annex A	(informative) Trade name declarations .....	60
Annex B	(informative) Media selection for fieldbus systems .....	62
B.1	General .....	62
B.2	Cabled media .....	62
B.3	Wireless media .....	62
B.4	Media needing special consideration .....	62
B.5	Performance characteristics of open and public networks .....	63
	Bibliography .....	64
	Figure 1 – Example of a fieldbus system .....	9
	Figure 2 – Concept of DL/AL to separate service and protocol parts .....	10
	Figure 3 – Basic fieldbus reference model .....	11
	Figure 4 – General model of physical layer .....	12
	Figure 5 – Relationship of the Data-link layer to other fieldbus layers and to users of the fieldbus data-link service .....	13
	Figure 6 – Relationship of the fieldbus Application layer to other fieldbus layers and to users of the fieldbus application service .....	14
	Figure 7 – Structure of communication profile families .....	17
	Figure 8 – Example of a CPF structure .....	18
	Figure 9 – Document structure of IEC 61918 and the CPF specific part of IEC 61784-5 .....	24
	Figure 10 – Relationship to the OSI Basic Reference Model .....	35
	Figure 11 – Architectural positioning of the fieldbus application layer .....	35
	Figure 12 – Client/server interactions .....	38
	Figure 13 – Pull model interactions .....	39
	Figure 14 – Push model interactions .....	39
	Figure 15 – APOs services conveyed by the FAL .....	41
	Figure 16 – Application entity structure .....	43
	Figure 17 – Example FAL ASEs .....	44
	Figure 18 – FAL management of objects .....	45
	Figure 19 – ASE service conveyance .....	46
	Figure 20 – Defined and established AREPs .....	48
	Figure 21 – FAL architectural components .....	50
	Figure 22 – Data-type class hierarchy example .....	53
	Table 1 – OSI and IEC 61158 layers .....	11
	Table 2 – CPF, CP, and type relations .....	19
	Table 3 – Types of timeliness defined for publisher/subscriber interactions .....	40
	Table A.1 – Trade names of CPFs and CPs .....	60

# INDUSTRIAL COMMUNICATION NETWORKS – FIELDBUS SPECIFICATIONS –

## Part 1: Overview and guidance for the IEC 61158 and IEC 61784 series

### 1 Scope

This document specifies the generic concept of fieldbuses.

This document also presents an overview and guidance for the IEC 61158 series by:

- explaining the structure and content of the IEC 61158 series;
- relating the structure of the IEC 61158 series to the ISO/IEC 7498-1 OSI Basic Reference Model;
- showing the logical structure of the IEC 61784 series;
- showing how to use parts of the IEC 61158 series in combination with the IEC 61784 series;
- providing explanations of some aspects of the IEC 61158 series that are common to the type specific parts of the IEC 61158-5 including the application layer service description concepts and the generic fieldbus data types.

### 2 Normative references

None.

### 3 Terms, definitions and abbreviated terms

#### 3.1 Terms and definitions

For the purposes of this document, the following terms and definitions apply.

##### 3.1.1

##### **communication system**

arrangement of hardware, software and propagation media to allow the transfer of messages from one application to another

##### 3.1.2

##### **fieldbus**

communication system based on serial data transfer as typically used in industrial automation and process control applications

##### 3.1.3

##### **fieldbus system**

system using a fieldbus with connected devices

##### 3.1.4

##### **message**

ordered series of octets intended to convey information

[SOURCE: ISO/IEC 2382-16:1996, 16.02.01, modified]

### 3.1.5

#### **network**

all of the media, connectors, repeaters, routers, gateways and associated node communication elements by which a given set of communicating devices are interconnected

## 3.2 Abbreviations

For the purposes of this document, the following abbreviations, based partially on the concepts developed in ISO/IEC 7498-1, apply:

AE	application entity
AL	application layer (N = 7)
APDU	application layer protocol data unit
APO	application process object
AR	application relationship
AREP	application relationship endpoint
ASE	application service element
CP	communication profile
CPF	communication profile family
DL-	data-link layer (as a prefix)
DLL	data-link layer (N = 2)
FAL	fieldbus application layer
FSCP	functional safety communication profile
IETF	Internet Engineering Task Force
IO	input output
IP	Internet protocol (see RFC 791)
kbit/s	thousand bit per second
Mbit/s	million bit per second
LME	layer management entity
(n)-layer	layer <i>n</i> of the OSI basic reference model
OSI	open systems interconnection
Ph-	physical layer (as a prefix)
PhL	physical layer (N = 1)
SIL	safety integrity level

## 4 Guidelines for implementers and users

### 4.1 Background and purpose

Communication in global markets requires a global understanding of a specification (standard or not). ISO/OSI related specifications provide a common basis for understanding and acceptance between international experts (manufacturers and end-users).

Examples are

- ISO/IEC 7498-1 for general layering and structuring;
- ISO/IEC 9545 for general application layer modeling;
- ISO/IEC 8886 for data-link layer modeling.

The IEC 61158 series specifies a number of different fieldbus types in each of its parts (IEC 61158-2 and the type specific parts of IEC 61158-3-*tt*, IEC 61158-4-*tt*, IEC 61158-5-*tt* and IEC 61158-6-*tt*). As a result of the editorial harmonization work done by IEC, each PhL, DLL and AL specification within IEC 61158 is shown in a homogeneous way. The description of each layer offers, as far as possible, common views, concepts, definitions, and descriptive methods.

NOTE The list of IEC 61158 parts is abbreviated as IEC 61158-3-*tt*, IEC 61158-4-*tt*, IEC 61158-5-*tt*, or IEC 61158-6-*tt*, where *tt* represents one or more type numbers.

This common approach has been adopted to assist users and implementers in understanding the several specifications. It is also intended to assist in comparing available products and their communications-related features.

## 4.2 Supported options

Most of the fieldbus types specified in the IEC 61158 series include a range of selectable and configurable options within their detailed specifications. In general, only certain restricted combinations of options will interwork or interoperate correctly.

The recommended combinations of options are collected in IEC 61784-1 and IEC 61784-2.

IEC 61784-1 and IEC 61784-2 provide users and implementers with details of supported fieldbus specifications based on selected options that are intended to work together consistently and correctly. In most cases, available product demonstrations and working plant experience support these profiles.

Annex A of IEC 61784-1 and Annex A of IEC 61784-2 help select the needed fieldbus by showing the key features of each of the profiled fieldbus protocol families.

As a result, the route map recommended to select a fieldbus is:

- Clause 5 to Clause 8 of this part of IEC 61158;
- IEC 61784-1, Annex A: Communication concepts;
- IEC 61784-2, Annex A: Performance indicator calculations;
- IEC 61784-1 and IEC 61784-2, Communication profile family;
- the parts of IEC 61158 as referenced in IEC 61784-1 and IEC 61784-2 for the selected communication profile of interest.

## 4.3 Benefits from using a common and formal style

The benefits gained from using a common and formal style to specify the communication system are:

- the common look and feel of a specification saves effort during evaluation;
- a common structure helps to identify and to specify common parts and contents;
- the common approach represents a first step to ensure long-term quality and stability;
- the missing parts and items of any specification are more readily identified by comparison with the other specifications, leading to a simplified review and evaluation procedure;
- a common basis facilitates the development of test and certification procedures;
- the modular concepts support future enhancements, extensions and adaptation of new technologies.

## 5 Concept of the IEC 61158 series

Conceptually, a fieldbus is an industrial digital communication network for integration of industrial control and instrumentation devices into a system. Examples of such devices are transducers, sensors, actuators and controllers.

The IEC 61158 series specifies a number of fieldbus protocol types. Each protocol type is designed to permit multiple measurement and control devices to communicate. Devices communicate directly only with other devices of the same protocol type. The basic requirements of industrial communication networks for measurement and control are given in Clause 11.

Devices which use the same lower-layer protocols in a compatible fashion but differ in their higher-layer protocols may be able to share a lower-layer medium.

In all cases, a particular data-link layer protocol type may be used without restriction when coupled with physical layer and application layer protocols of the same type or with other combinations as specified in IEC 61784-1 and IEC 61784-2. Use of the various protocol types in other combinations may require permission from their respective copyright holders.

The protocol types in IEC 61158 have been engineered to support information processing, monitoring and control systems for any industrial sector and related domains. An example application for high-integrity low-level communication between sensors, actuators and local controllers in a process plant, together with the interconnection of programmable controllers, is shown in Figure 1.

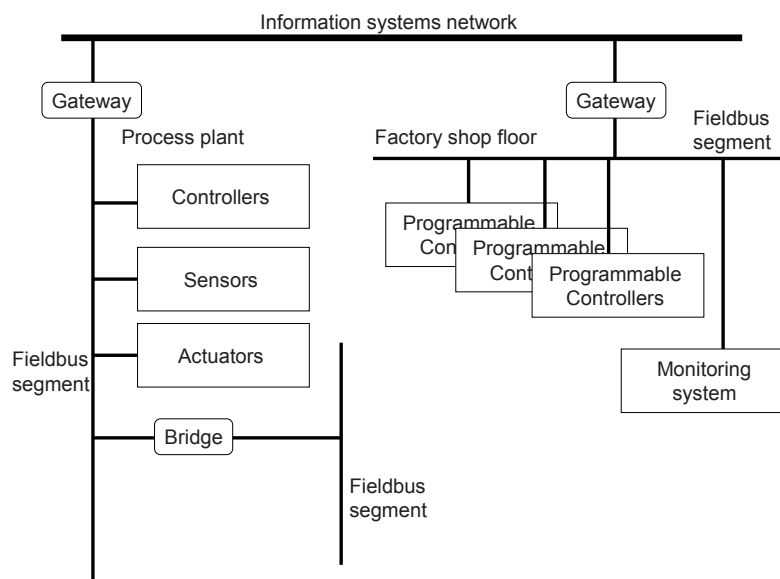

**Figure 1 – Example of a fieldbus system**

A number of fieldbus types are specified in the IEC 61158 series using the following concepts for decomposition.

- a) **First concept:** The complex communication task is divided into different layers based on an adaptation of ISO/IEC 7498-1, the ISO/OSI Basic Reference Model, thereby facilitating well-structured functions and interfaces (see Clause 6). This has the following benefits:
  - decomposition of complex tasks;
  - modular structure to adapt different technologies.
- b) **Second concept:** Each fieldbus type is composed of one or more layer specifications.

Most types include a number of services and protocol options that require an appropriate selection to support a working system. Compatible selections of options and services within one of the IEC 61158 fieldbus types are specified as standardized communication profiles in IEC 61784-1 and IEC 61784-2. Most of these profiles are supported by consortia or trade associations which are identified in the profile specification.

- c) **Third concept:** The physical, data-link and application layers are described in complementary ways, in terms of the offered services and the protocol which provides those services.

Figure 2 illustrates the differences between service and protocol viewpoints of the data-link and application layers. The protocol parts show the layer implementer's oriented view and the service parts show the layer user's oriented view.

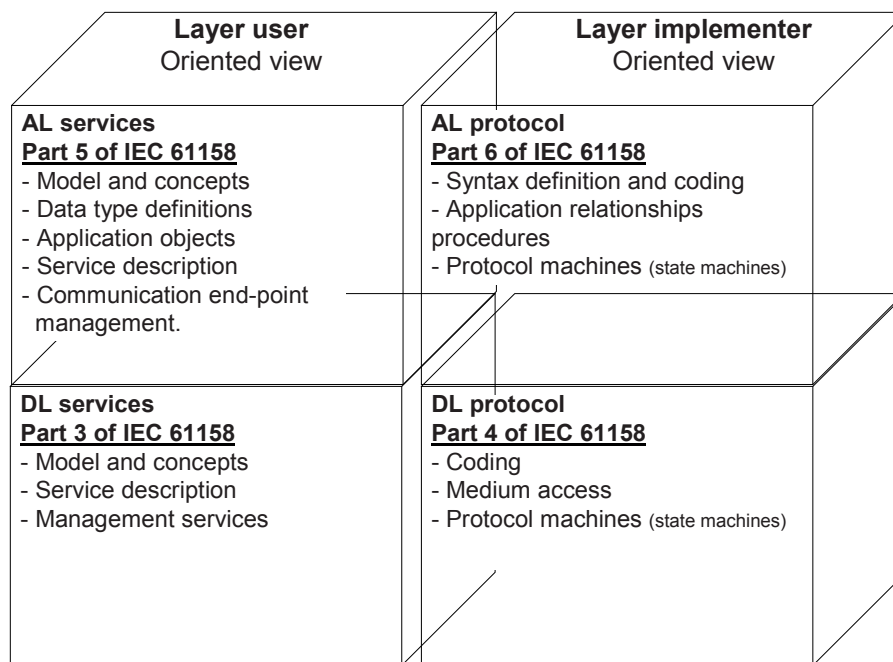

**Figure 2 – Concept of DL/AL to separate service and protocol parts**

The application layer structure is as follows:

- the "what" is described by application layer service elements (ASE) in the type specific parts of IEC 61158-5; and
- the "how" is described by application layer relationships (AR) in the type specific parts of IEC 61158-6.

The data-link layer structure is as follows:

- the "what" is described by data-link layer services and models in the type specific parts of IEC 61158-3; and
- the "how" is described by data-link layer protocol machines and medium access principles in the type specific parts of IEC 61158-4.

The physical layer is structured similarly, but, because its services are readily described, they are described in IEC 61158-2 together with the definitions of the physical protocols:

- the "what" is described by physical layer services and models, and
- the "how" is described by physical layer electrical and mechanical specifications.

## 6 Mapping onto the OSI Basic Reference Model

### 6.1 Overview

IEC 61158 protocol types are described using the principles, methodology and model of ISO/IEC 7498-1. The OSI model provides a layered approach to communications standards, whereby the layers can be developed and modified independently. IEC 61158 specifies functionality from top to bottom of a full OSI stack and, potentially, some functions for the users of the stack. Functions of the intermediate OSI layers, layers 3 through 6, may be consolidated into either the IEC 61158 data-link layer or the IEC 61158 application layer, or may be realized by a separate layer. Likewise, some features common to users of the fieldbus application layer may be provided by the IEC 61158 application layer to simplify user operation.

Table 1 shows the OSI layers, their functions, and the equivalent layers in the IEC 61158 basic fieldbus reference model (see Figure 3).

**Table 1 – OSI and IEC 61158 layers**

OSI layer	Function	IEC 61158 layer
7 <b>Application</b>	Translates demands placed on the communications stack into a form understood by the lower layers and vice versa	Application (IEC 61158-5- <i>tt</i> , IEC 61158-6- <i>tt</i> )
6 <b>Presentation</b>	Converts data to/from standardized network formats	↑
5 <b>Session</b>	Creates and manages dialogue among lower layers	↑
4 <b>Transport</b>	Provides transparent reliable data transfer (end-to-end transfer across a network which may include multiple links)	↓ or ↑
3 <b>Network</b>	Performs message routing	↓ or ↑
2 <b>Data-link</b>	Controls access to the communication medium. Performs error detection, (point-to-point transfer on a link)	Data-link (IEC 61158-3- <i>tt</i> , IEC 61158-4- <i>tt</i> )
1 <b>Physical</b>	Encodes/decodes signals for transmission/reception in a form appropriate to the communications medium. Specifies communication media characteristics	Physical (IEC 61158-2)

NOTE -*tt* is a placeholder for the part numbers representing types.

NOTE ↓ and ↑ indicate that the functionality of this layer, when present, is included in the fieldbus layer that is nearest in the direction of the arrow. Thus it is possible that the network and transport functionality are included in either the data-link or application layers, and it is possible that the session and presentation functionality are included in the application layer but not in the data-link layer.

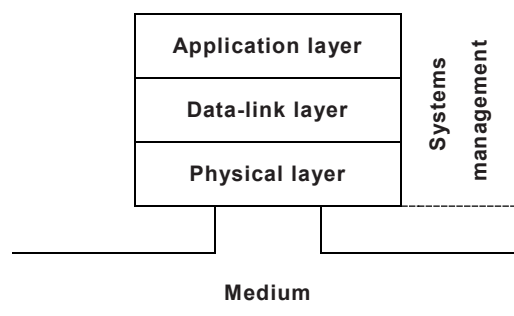

**Figure 3 – Basic fieldbus reference model**

### 6.2 Physical layer service and protocol

IEC 61158-2 comprises physical layer specifications corresponding to many of the different DL-Layer protocol types specified in the type specific parts of IEC 61158-4.

NOTE 1 The type numbers used are consistent throughout the IEC 61158 series.

NOTE 2 Not all types have a physical layer specification in IEC 61158-2. In that case the communication profile in IEC 61784-1 or IEC 61784-2 provides appropriate references to other standards.

NOTE 3 For ease of reference, type numbers are given in clause names. This means that the specification given therein applies to this type but does not exclude its use for other types.

NOTE 4 It is up to the user of IEC 61158 to select interoperating sets of provisions. Refer to the IEC 61784-1 and IEC 61784-2 for standardized communication profiles based on IEC 61158 .

A general model of the physical layer is shown in Figure 4.

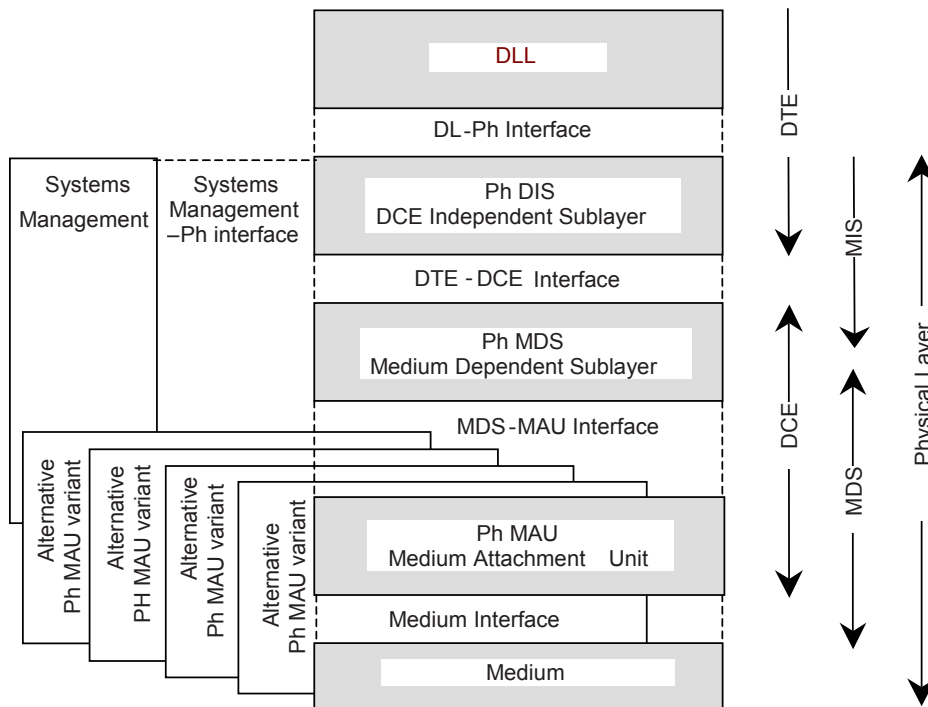

**Figure 4 – General model of physical layer**

NOTE 5 The protocol types use a subset of the structure elements.

NOTE 6 Since Type 8 uses a more complex DIS than the other types, it uses the term MIS to differentiate.

The common characteristics for all variants and types are as follows:

- digital data transmission; and
- either half-duplex communication (bi-directional but in only one direction at a time) or full-duplex communication.

### 6.3 Data-link layer service

The data-link service is provided by the data-link protocol making use of the services available from the physical layer. This and related parts of the IEC 61158 series defines the data-link service characteristics that the immediately higher-level protocol may exploit. The relationship between the international standards for fieldbus data-link service, fieldbus data-link protocol, fieldbus application protocol and systems management is illustrated in Figure 5.

NOTE Systems management, as used in the IEC 61158 series, is a local mechanism for managing the layer protocols.



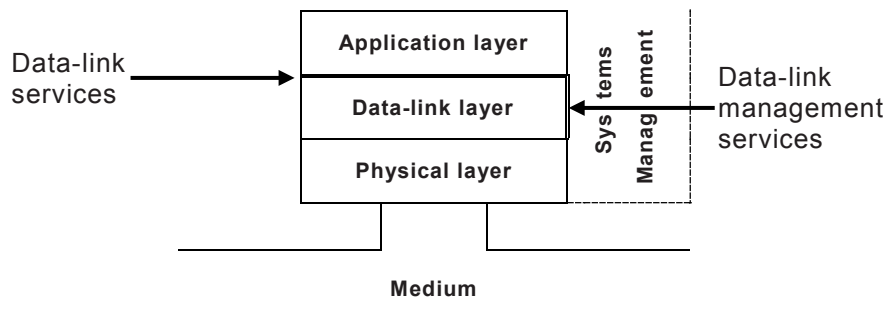

**Figure 5 – Relationship of the Data-link layer to other fieldbus layers and to users of the fieldbus data-link service**

Throughout the set of fieldbus standards, the term “service” refers to the abstract capability provided by one layer of the OSI Basic Reference Model to the layer immediately above. Thus, a data-link service defined in IEC 61158 is a conceptual architectural service, independent of administrative and implementation divisions.

#### 6.4 Data-link layer protocol

The data-link protocol provides the data-link service by making use of the services available from the physical layer. The relationship between the International Standards for fieldbus data-link service, fieldbus data-link protocol, fieldbus physical service and systems management is illustrated in Figure 5.

NOTE 1 Systems management, as used in the IEC 61158 series, is a local mechanism for managing the layer protocols.

NOTE 2 Not all types have a data-link layer specification. In that case the communication profile in IEC 61784-1 or IEC 61784-2 provides appropriate references to other standards.

The primary aim of the data-link protocol standards is to provide a set of rules for communication expressed in terms of the procedures to be carried out by peer data-link entities (DLEs) at the time of communication. These rules for communication are intended to provide a sound basis for development in order to serve a variety of purposes:

- a) as a guide for implementers and designers;
- b) for use in the testing and procurement of equipment;
- c) as part of an agreement for the admittance of systems into the open systems environment;
- d) as a refinement to the understanding of time-critical communications within OSI.

These data-link protocol standards are concerned, in particular, with the communication and interworking of sensors, effectors and other automation devices, using these standards, together with other standards positioned within the OSI or fieldbus reference models; otherwise, incompatible systems may work together in any combination.

#### 6.5 Application layer service

The application service is provided by the application protocol making use of the services available from the data-link or other immediately lower layer. Each part of the IEC 61158-5 series defines the application service characteristics that any immediately higher-level protocols may exploit. The relationship between the international standards for fieldbus application service, fieldbus application protocol and systems management is illustrated in Figure 6.

NOTE Systems management, as used in the IEC 61158 series, is a local mechanism for managing the layer protocols.

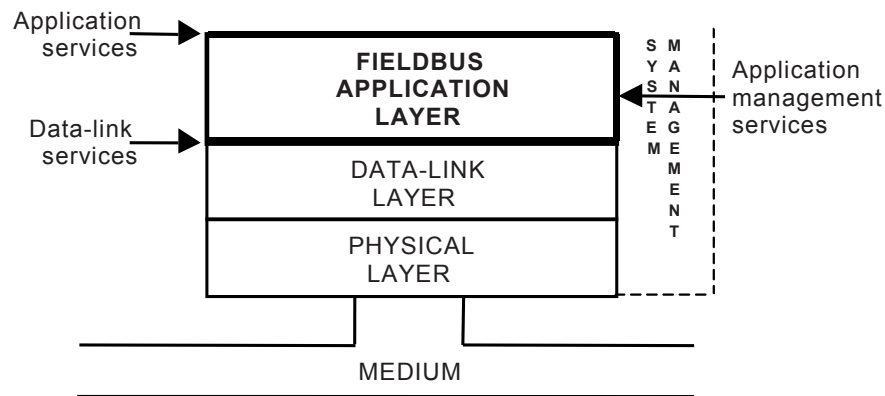

**Figure 6 – Relationship of the fieldbus Application layer to other fieldbus layers and to users of the fieldbus application service**

## 6.6 Application layer protocol

The application protocol provides the application service by making use of the services available from the data-link layer or other immediately lower layer. The relationship between the International Standards for fieldbus application service, fieldbus application protocol, fieldbus data-link service and system management is illustrated in Figure 6.

NOTE Systems management, as used in the IEC 61158 series, is a local mechanism for managing the layer protocols.

An application process uses the fieldbus application layer services to exchange information with other application processes. The services define the abstract interface between the application process and the application layer.

The application layer protocol is the set of rules that governs the format and meaning of the information exchange between the application layers in various devices. The application layer uses the protocol to implement the application layer services definitions.

The protocol machine defines the various states of an application layer and the valid transitions between the states. It may be considered as a finite state machine. The protocol machine is described using state tables. The information is exchanged between the application process and the protocol machine through application service data units. The protocol machine exchanges information with other protocol machines through application protocol data units (APDU).

This set of application layer standards does not contain test procedures to ensure compliance with such requirements.

The primary aim of an application layer protocol in IEC 61158 is to provide a set of rules for communication expressed in terms of the procedures to be carried out by peer application entities (AE) at the time of communication. These rules for communication are intended to provide a sound basis for development in order to serve a variety of purposes:

- a) as a guide for implementers and designers;
- b) for use in the testing and procurement of equipment;
- c) as part of an agreement for the admittance of systems into the open systems environment;
- d) as a refinement to the understanding of time-critical communications within OSI.

IEC 61158 is concerned, in particular, with the communication and interworking of sensors, effectors and other automation devices, by using IEC 61158 together with other standards

positioned within the OSI or fieldbus reference models; otherwise, incompatible systems may work together in any combination.

## 7 Structure of IEC 61158 and IEC 61784 series

### 7.1 The IEC 61158 physical layer

The IEC 61158 physical layer receives data units from the data-link layer, encapsulates them if necessary by adding communications framing information, encodes the bits and framing information into signals, and transmits the resulting physical signals to the transmission medium connected to the transmitting node.

Signals are then received at one or more other node(s) and decoded, and any communications framing information is checked and removed, before the data units are passed to the data-link layer of the receiving device.

IEC 61158-2 comprises physical layer specifications to support the DL-protocol types specified in the IEC 61158 data-link layer. It defines the services provided

- a) to the various types of fieldbus data-link layer at the boundary between the data-link and physical layers of the fieldbus reference model;
- b) to systems management at the boundary between the physical layer and systems management of the fieldbus reference model.

NOTE This combination of physical service definition and physical protocol specification into a single standard is an historic anomaly; it is not common standards practice.

### 7.2 The IEC 61158 data-link layer

In the absence of persistent errors, the IEC 61158 data-link layers (see IEC 61158-3-*tt* and IEC 61158-4-*tt*) provide basic time-critical support for data communications among devices in an automation environment. The term “time-critical” is used to describe applications having a time-window, within which one or more specified actions are required to be completed with some defined level of certainty. Failure to complete specified actions within the time window risks failure of the applications requesting the actions, with attendant risk to equipment, plant and possibly human life.

IEC 61158 data-link layer specifies, in an abstract way, the externally visible service provided by the fieldbus data-link layer in terms of

- a) the primitive actions and events of the service;
- b) the parameters associated with each primitive action and event, and the form which they take;
- c) the interrelationship between these actions and events, and their valid sequences.

IEC 61158 data-link layer defines the services provided

- d) to the various types of fieldbus application layer at the boundary between the application and data-link layers of the fieldbus reference model;
- e) to systems management at the boundary between the data-link layer and systems management of the fieldbus reference model.

IEC 61158-4-*tt* define a number of distinct and non-interoperable fieldbus data-link protocols. Each protocol is most closely related to, and lies within the field of application of, the corresponding services of IEC 61158-3-*tt*.

### 7.3 The IEC 61158 application layer

The IEC 61158 application layers (see IEC 61158-5-*tt* and IEC 61158-6-*tt*) are designed to support the conveyance of time-critical application requests and responses among devices in an automation environment.

The IEC 61158-5 series specifies interactions between remote applications in terms of

- a) an abstract model for defining application resources (objects) capable of being manipulated by users via the use of fieldbus application layer (FAL) services;
- b) the service primitives (interactions between the FAL and the FAL user) associated with each FAL service;
- c) the parameters associated with each service primitive;
- d) the interrelationship between, and the valid sequences of, the primitives for each service.

Although these services specify, from the perspective of applications, how request and responses are issued and delivered, they do not include a specification of what the requesting and responding applications are to do with them. That is, the behavioral aspects of the applications are not specified; only a definition of what requests and responses they can send/receive is specified. This permits greater flexibility to the FAL users in standardizing such object behavior. In addition to these services, some supporting services are also defined to provide access to the FAL to control certain aspects of its operation.

The IEC 61158-5 series defines the services provided

- a) to the various user(s) of the fieldbus application layer at the boundary between the user(s) and the application layer of the fieldbus reference model;
- b) to systems management at the boundary between the application layer and systems management of the fieldbus reference model.

The IEC 61158-6 series defines a number of distinct and non-interoperable fieldbus application protocols. Each protocol is most closely related to, and lies within the field of application of, the services of the corresponding part of the IEC 61158-5 series.

### 7.4 IEC 61784-1 and IEC 61784-2 fieldbus profiles

IEC 61784-1 and IEC 61784-2 provide sets of communication profiles (CP) in the sense of ISO/IEC TR 10000-1. These answer the need of identifying the protocol families co-existing within the IEC 61158 series, as a result of the international harmonization of fieldbus technologies available on the market. More specifically, these profiles help to correctly state the compliance to the IEC 61158 series, and to avoid the spreading of divergent implementations, which would limit its use, clearness and understanding. Additional profiles to address specific market concerns, such as functional safety or information security, may be addressed by future parts of IEC 61158.

IEC 61784-1 and IEC 61784-2 contain several communication profile families (CPF), which specify one or more communication profiles. Such profiles identify, in a strict sense, protocol subsets of the IEC 61158 series via protocol specific communication profiles. They do not define device-type-specific communication profiles for the purpose of guiding manufacturers in feature set selection – for example, in selecting the minimum set of communication services and protocol to implement a specific class of devices, such as generic slaves or transmitters ("implementation profiles"). Neither do they define device profiles that specify communication profiles together with application functions needed to answer the need of a specific application ("application profiles").

NOTE IEC/TR 62390 provides guidance for the development of device profiles for industrial field devices and control devices. IEC/TR 62390 also defines the relation between device profiles and communication profiles including the levels of functional compatibility and the relations between profiles and products.

It is also important to clarify that interoperability – defined as the ability of two or more network systems to exchange information and to make mutual use of the information that has been exchanged (see 3.2.1 of ISO/IEC TR 10000-1) – can be directly achieved on the same link only for those devices complying with the same communication profile.

Profiles contained in IEC 61784-1 and IEC 61784-2 are made up of references to IEC 61158-2 and 61158-3-*tt* through IEC 61158-6-*tt*, ISO/IEC 8802-3 or IEEE 802.3 and other International Standards, Technical Specifications or worldwide-accepted standards, as appropriate. Each profile is required to reference at least one part of IEC 61158-2 and 61158-3-*tt* through IEC 61158-6-*tt*.

Two or more profiles, which are related to a common family, are specified within a CPF.

IEC 61784-2 specifies additional profiles that meet the industrial automation market objective of identifying real-time Ethernet (RTE) communication networks coexisting with ISO/IEC 8802-3 or IEEE 802.3 (commonly known as Ethernet). These RTE communication networks use provision from ISO/IEC 8802-3 for the lower communication stack layers and, additionally, provide more predictable and reliable real-time data transfer and means for support of precise synchronization of automation equipment.

More specifically, these profiles help to correctly state the compliance of RTE communication networks with ISO/IEC 8802-3 or IEEE 802.3, and to avoid the spreading of divergent implementations.

Each profile selects an appropriate consistent and compatible subset of services and protocols from the total available set of communication types that are defined and modelled in IEC 61158 and other standards. For the selected subset of PhL, services, and protocols, the profile also describes any possible or necessary constraints in parameter values.

The document structure of communication profile families (CPF) is shown in Figure 7.

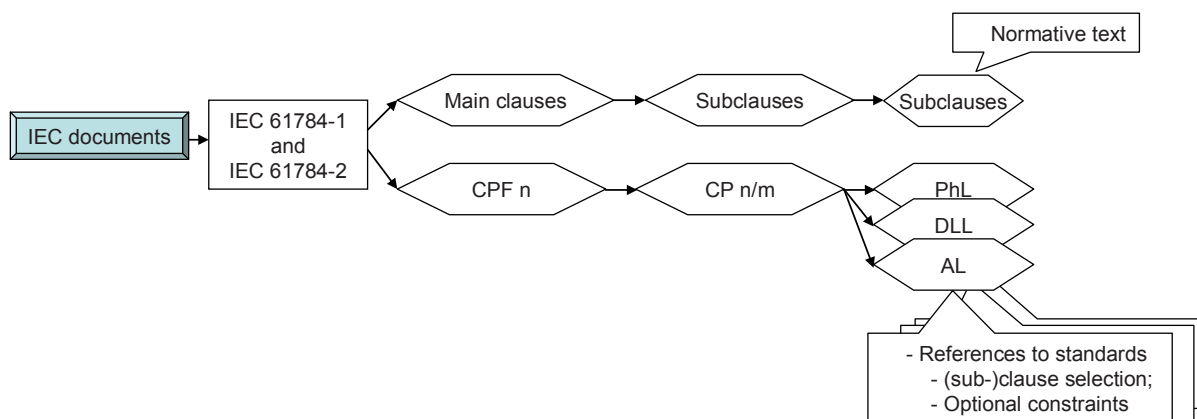

n is a number of a CPF; m is a number of a CP within a CPF.

**Figure 7 – Structure of communication profile families**

IEC 61784-1, IEC 61784-2 and future parts and sub-series of the IEC 61784 series specify communication profile families (CPF). A CPF contains at least one communication profile (CP). A CP is always structured to specify PhL, DL, and AL by reference to clauses and subclauses within the IEC 61158 series and other appropriate international standards. These subclauses provide at least one reference to an international standard. Either the international standard is referenced completely or it is referenced by a list of required clauses and subclauses marked YES or NO. YES means the clause or subclause applies, NO means that it does not apply. Optional information may be provided to specify constraints.

Figure 8 is an example of a CPF structure.

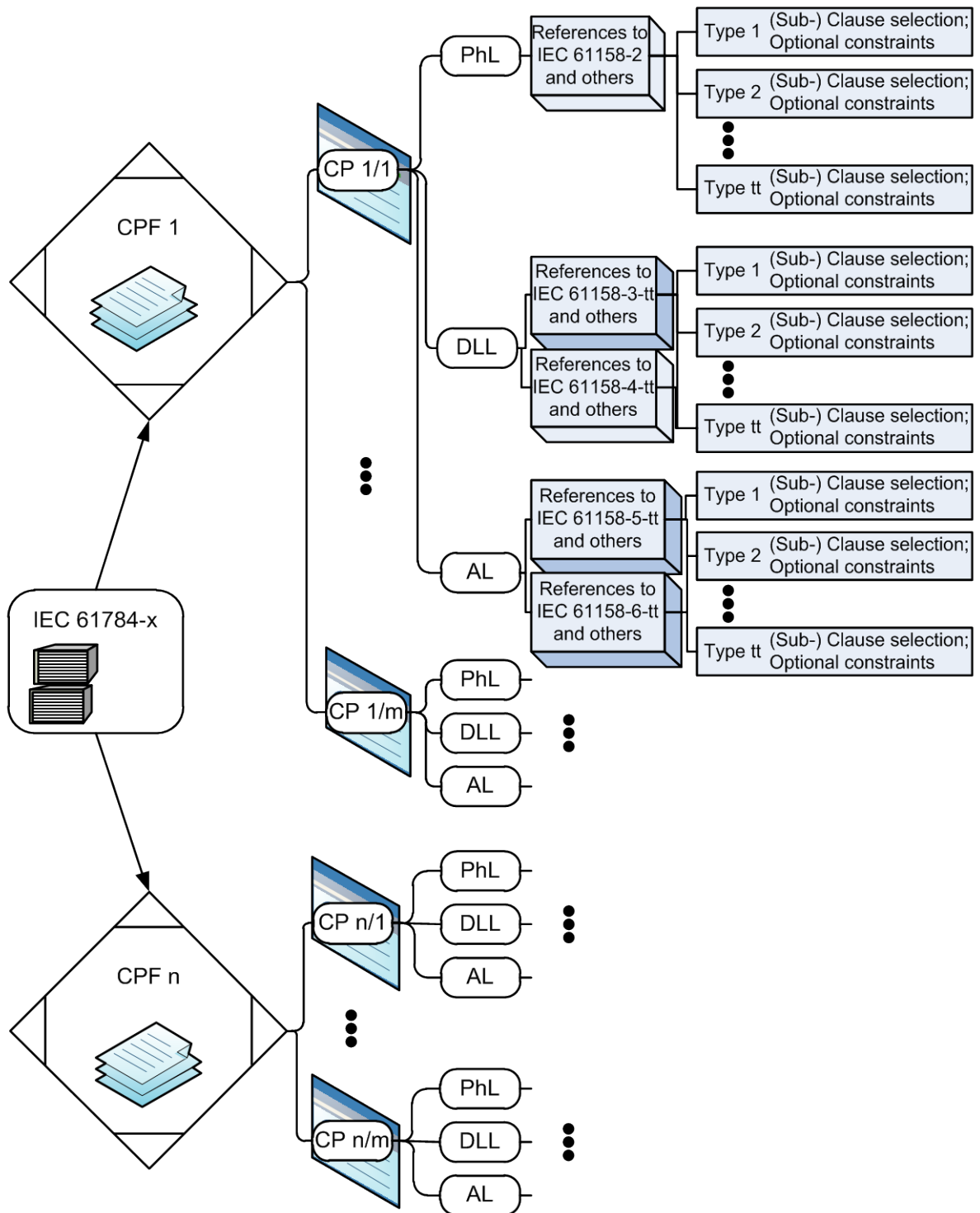

**Key**

x = 1 or 2

n = number of a CPF

m = number of a CP within a CPF

tt = Type number

IEC 61158-3-tt means a reference to one or more existing Type specific sub-parts.

**Figure 8 – Example of a CPF structure**

Table 2 shows the Communication Profile Families (CPF) that are defined in IEC 61784-1 and IEC 61784-2. It shows the link between technologies and CPFs with their associated CPs and corresponding type numbers in the IEC 61158 series.

**Table 2 – CPF, CP, and type relations**

Communication Profiles in IEC 61784			Corresponding IEC 61158 types to CPs		
CPF	Technology name	IEC 61784 (Sub-)Parts	CP number	Type number	IEC 61158 (Sub-)Parts
1	FOUNDATION™ fieldbus	1, 3-1, 5-1	CP 1/1 FOUNDATION™ H1	1,9	1, 2, 3-1, 4-1, 5-9, 6-9
		1, 3-1, 5-1	CP 1/2 FOUNDATION™ HSE	5	1, 5-5, 6-5
		1, 3-1	CP 1/3 FOUNDATION™ H2	1,9	1, 2, 3-1, 4-1, 5-9, 6-9
2	CIP™	1, 5-2	CP 2/1 ControlNet™	2	1, 2, 3-2, 4-2, 5-2, 6-2
		1, 2, 3-2, 5-2	CP 2/2 EtherNet/IP™	2	1, 4-2, 5-2, 6-2
		1, 3-2, 5-2	CP 2/3 DeviceNet™	2	1, 4-2, 5-2, 6-2
3	PROFIBUS & PROFINET	1, 3-3, 5-3	CP 3/1 PROFIBUS DP	3	1, 2, 3-3, 4-3, 5-3, 6-3
		1, 3-3, 5-3	CP 3/2 PROFIBUS PA	3	1, 2, 3-3, 4-3, 5-3, 6-3
		—	CP 3/3 Void	—	—
		2, 3-3, 5-3	CP 3/4 PROFINET IO CC-A	10	1, 5-10, 6-10
		2, 3-3, 5-3	CP 3/5 PROFINET IO CC-B	10	1, 5-10, 6-10
		2, 3-3, 5-3	CP 3/6 PROFINET IO CC-C	10	1, 5-10, 6-10
4	P-NET®	1, 5-4	CP 4/1 P-NET RS-485	4	1, 2, 3-4, 4-4, 5-4, 6-4
		—	CP 4/2 removed	—	—
		2, 5-4	CP 4/3 P-NET on IP	4	1, 3-4, 4-4, 5-4, 6-4
5	WorldFIP®	1	CP 5/1 WorldFIP	7	1, 2, 3-7, 4-7, 5-7, 6-7
		1	CP 5/2 WorldFIP with subMMS	7	1, 2, 3-7, 4-7, 5-7, 6-7
		1	CP 5/3 WorldFIP minimal for TCP/IP	7	1, 2, 3-7, 4-7, 5-7, 6-7
6	INTERBUS®	1, 3-6, 5-6	CP 6/1 INTERBUS	8	1, 2, 3-8, 4-8, 5-8, 6-8
		1, 3-6, 5-6	CP 6/2 INTERBUS TCP/IP	8	1, 2, 3-8, 4-8, 5-8, 6-8
		1, 3-6, 5-6	CP 6/3 INTERBUS subset of CP 6/1	8	1, 2, 3-8, 4-8, 5-8, 6-8
		2, 5-6	CP 6/4	8	1, 2, 3-8, 4-8, 5-8, 6-8, 5-10, 6-10
		2, 5-6	CP 6/5	8	
		2, 5-6	CP 6/6	8	
7	This CPF and the associated Type 6 are deleted for lack of market relevance.				
8	CC-Link	1, 3-8, 5-8	CP 8/1 CC-Link/V1	18	1, 2, 3-18, 4-18, 5-18, 6-18
		1, 5-8	CP 8/2 CC-Link/V2	18	1, 2, 3-18, 4-18, 5-18, 6-18
		1, 5-8	CP 8/3 CC-Link/LT	18	1, 2, 3-18, 4-18, 5-18, 6-18
		2, 5-8	CP 8/4 CC-Link IE Controller Network	23	1, 5-23, 6-23
		2, 5-8	CP 8/5 CC-Link IE Field Network	23	1, 5-23, 6-23
9	HART®	1	CP 9/1 HART	20	1, 2, 3-20, 4-20, 5-20, 6-20
		—	CP 9/2 WirelessHART® see IEC 62591, Clause 9	20	See IEC 62591
10	Vnet/IP	2, 5-10	CP 10/1 Vnet/IP	17	1, 2, 3-17, 4-17, 5-17, 6-17
11	TCnet	2, 5-11	CP 11/1 TCnet-star	11	1, 2, 3-11, 4-11, 5-11, 6-11
		2, 5-11	CP 11/2 TCnet-loop 100	11	1, 2, 3-11, 4-11, 5-11, 6-11



Communication Profiles in IEC 61784			Corresponding IEC 61158 types to CPs		
CPF	Technology name	IEC 61784 (Sub-)Parts	CP number	Type number	IEC 61158 (Sub-)Parts
		2, 5-11	CP 11/3 TCnet-loop 1G	11	1, 2, 3-11, 4-11, 5-11, 6-11
12	EtherCAT®	2, 3-12, 5-12	CP 12/1	12	1, 2, 3-12, 4-12, 5-12, 6-12
		2, 3-12, 5-12	CP 12/2	12	1, 2, 3-12, 4-12, 5-12, 6-12
13	Ethernet POWERLINK	2, 3-13, 5-13	CP 13/1 POWERLINK	13	1, 3-13, 4-13, 5-13, 6-13
14	EPA	2, 3-14, 5-14	CP 14/1 NRT	14	1, 3-14, 4-14, 5-14, 6-14
		2, 3-14, 5-14	CP 14/2 RT	14	1, 3-14, 4-14, 5-14, 6-14
		2, 5-14	CP 14/3 FRT	14	1, 3-14, 4-14, 5-14, 6-14
		2, 3-14, 5-14	CP 14/4 MRT	14	1, 3-14, 4-14, 5-14, 6-14
15	MODBUS®-RTPS	2, 5-15	CP 15/1 MODBUS TCP	15	1, 5-15, 6-15
		2, 5-15	CP 15/2 RTPS	15	1, 5-15, 6-15
16	SERCOS	1, 5-16	CP 16/1 SERCOS I	16	1, 2, 3-16, 4-16, 5-16, 6-16
		1, 5-16	CP 16/2 SERCOS II	16	1, 2, 3-16, 4-16, 5-16, 6-16
		2, 3-2, 5-16	CP 16/3 SERCOS III	19	1, 3-19, 4-19, 5-19, 6-19
17	RAPIEnet	2, 5-17	CP 17/1 RAPIEnet	21	1, 3-21, 4-21, 5-21, 6-21
18	SafetyNET p™	2, 3-18, 5-18	CP 18/1 SafetyNET p RTFL	22	1, 3-22, 4-22, 5-22, 6-22
		2, 3-18, 5-18	CP 18/2 SafetyNET p RTFN	22	1, 3-22, 4-22, 5-22, 6-22
19	MECHATROLINK	1, 5-19	CP 19/1 MECHATROLINK-II	24	1, 3-24, 4-24, 5-24, 6-24
		1, 5-19	CP 19/2 MECHATROLINK-III	24	1, 3-24, 4-24, 5-24, 6-24

NOTE The trademark and trade name declarations are given in Annex A.

## 7.5 IEC 61784-3 functional safety communication profiles

### 7.5.1 General

The need to develop safety communications systems is the result of an industrial background where safety requirements have been driven by increasing legislation and market demands; to protect personnel, but also assets. Safety system development has historically followed a similar path to standard control system development, where programmable and networked equipment has fulfilled increasing complexity and flexibility requirements of automation applications. The development of safety networks has brought similar benefits to safety systems, including reduced wiring, ease of configuration and extended diagnostics capabilities.

### 7.5.2 General concepts and technology-specific profiles

The IEC 61784-3 series is divided into several parts, a generic one, and several technology specific parts:

- IEC 61784-3: Functional safety fieldbuses – General rules and profile definitions;
- IEC 61784-3-*n*: Functional safety fieldbuses – Additional specifications for CPF *n*.

IEC 61784-3 defines common principles for the transmission of safety-relevant messages among participants within a distributed network using fieldbus technology in accordance with the requirements of IEC 61508 series for functional safety. These mechanisms are intended to provide the necessary confidence in the transportation of information on a fieldbus in a safety-related system, or sufficient confidence of safe behavior in the event of fieldbus failures. They may be used in various industrial applications such as process control, manufacturing automation and machinery.



IEC 61784-3-*n* specifies functional safety communication profile(s) (FSCP's) for Communication Profile Family (CPF *n*), based on corresponding fieldbus communication profiles in IEC 61784-1 (or IEC 61784-2) and in IEC 61158:

- IEC 61784-3-1: FOUNDATION™ for Safety Instrumented Functions (CPF 1, FSCP 1/1);
- IEC 61784-3-2: CIP Safety™ (CPF 2, FSCP 2/1);
- IEC 61784-3-3: PROFIsafe™ (CPF 3, FSCP 3/1);
- IEC 61784-3-6: INTERBUS Safety™ (CPF 6, FSCP 6/7);
- IEC 61784-3-8: CC-Link Safety™ (CPF 8, FSCP 8/1);
- IEC 61784-3-12: Safety-over-EtherCAT® (CPF 12, FSCP 12/1);
- IEC 61784-3-13: openSAFETY™<sup>1</sup> (CPF 13, FSCP 13/1);
- IEC 61784-3-14: EPA Safety® (CPF 14, FSCP 14/1);
- IEC 61784-3-18: SafetyNET p™ (CPF 18, FSCP 18/1).

Achieving safety is a multi-level process.

- Functional safety communication profiles (FSCP) are specified for use in applications requiring functional safety up to a given Safety Integrity Level (SIL). However, the resulting SIL claim of a subsystem depends on the actual implementation and use of the selected functional safety communication profile within this subsystem.
- Product developers are responsible for correct implementation of the FSCP in a device, in accordance with all relevant safety standards for this device.
- System designers have the responsibility to ensure that the safety network is designed, configured and used appropriately to ensure safety for their application.

Additional measures need to be considered in any safety-related application to protect fieldbus systems against unauthorized access. However, safety and security have different requirements (e.g. life cycles), so these are handled separately (some requirements for security will be detailed in the IEC 62443 series). The security function can be implemented either within the devices, or at external access points.

If needed, specific installation guidelines for the functional safety communication profiles are included in IEC 61918 and/or IEC 61784-5, and only referenced from IEC 61784-3.

IEC 61508 requires increased levels for electromagnetic compatibility (EMC). IEC 61784-3 indicates how appropriate levels should be chosen, according to the Safety Requirements Specifications, by reference to other standards.

Non-compliant devices on the bus could seriously disrupt operation, and thus compromise availability (because of spurious trips, including nuisance trips), subsequently causing the safety feature to be disabled by the user.

Therefore, it is strongly recommended that all products connected to the fieldbus in a safety-related application (even the standard ones) provide an appropriate conformity assessment to the relevant fieldbus protocol (for example manufacturer declaration or third-party assessment).

IEC 61784-3 does not cover electrical safety and intrinsic safety aspects.

### 7.5.3 Assessment Guideline

Before IEC 61784-3 was published, the German document GS-ET-26 (Principles for test and certification of bus systems for safety-relevant communication) had been used by many

---

<sup>1</sup> In the past the trade name of FSCP 13/1 (openSAFETY) had been Ethernet POWERLINK safety.

assessment bodies as reference document for the assessment of safety-related devices using functional safety communication technologies. This document covered both design and assessment aspects, but needed translation, updating and "internationalization".

The general principles for design of functional safety communication presented in this document have been used as input for IEC 61784-3 (generic part), which also includes in its Annex D a guideline for assessing a particular functional safety communication profile or communication system, as well as safety-related devices using these profiles: this guideline specifies how to verify the safety measures of a particular FSCP that are implemented by a product.

In addition, IEC/TR 62685 provides a separate Assessment Guideline for safety devices using IEC 61784-3 functional safety communication profiles (FSCPs). It covers the part of GS-ET-26 aspects which did not fit in the scope of IEC 61784-3: assessment aspects of safe communication such as test beds, proof of increased interference immunity (EMC for functional safety), electrical safety, and other environmental requirements.

NOTE 1 This Assessment Guideline is only applicable to safety devices for functional safe communication which are developed according to IEC 61508 and IEC 61784-3, and covers general industrial environments such as defined in IEC 61131-2 or IEC 61000-6-2 and process automation environments such as covered in the IEC 61326 series.

NOTE 2 IEC/TR 62685 has also been ratified as a Technical Report on European level (CLC/TR 62685). This will allow European assessment bodies to discard the GS-ET-26 document and replace it by both IEC 61784-3 and IEC/TR 62685.

## 7.6 IEC 61784-5 installation profiles

The IEC 61784-5 series specifies installation profiles for fieldbus communication networks in several parts, each part dedicated to one of the CPFs defined in IEC 61784-1 and IEC 61784-2 (see Table 2). These installation profiles are based on IEC 61918 which specifies the common requirements. Figure 9 shows the structure of IEC 61918 and the IEC 61784-5 series. The installation lifecycle is the basis for these standards. IEC 61918 is structured in clauses having the following headlines:

- IEC 61918 Clause 4: Installation planning;
- IEC 61918 Clause 5: Installation implementation;
- IEC 61918 Clause 6: Installation verification and installation acceptance test;
- IEC 61918 Clause 7: Installation administration;
- IEC 61918 Clause 8: Installation maintenance and installation troubleshooting.

The requirements for each phase of the installation life cycle are listed according to the logical sequence of the installation work. IEC 61918 defines the common installation aspects in Clause 4 to Clause 8 for the media that are applicable:

- Ethernet based networks;
- non-Ethernet based fieldbuses;
- safety communications;
- intrinsic safety communications;
- information security communications.

The installation requirements for each CP of a CPF *n* are defined in a dedicated Annex of the corresponding part *n* of IEC 61784-5. The requirements are expressed by referencing the applicable IEC 61918 requirements and by adding CP specific installation requirements when needed.

The numbering of the clauses and subclauses in the Annexes of each part of IEC 61784-5 corresponds to the numbering of the IEC 61918 main clauses and subclauses.

The annex clauses and subclauses of each part of IEC 61784-5 confirm, supplement, modify, or replace the specifications provided in the same clauses and subclauses of IEC 61918.

Where in the normative annexes of a part of IEC 61784-5 there is only the heading of a subclause, it means that the corresponding subclause of IEC 61918 applies as it is.

Figure 9 shows that Clause 1 of both IEC 61918 and each part of IEC 61784-5 specifies the relevant scope. IEC 61918 specifies installation requirements in Clauses 2 to 8. Each annex of each part of IEC 61784-5 selects the relevant installation requirements from IEC 61918 for a specific CP of the specified CPF, and provides the additions needed for the relevant CPs.

Clause 2 of each part of IEC 61784-5 describes the normative references; Clause 3 of each part of IEC 61784-5 describes additional terms, definitions and abbreviated terms for the relevant CPF; Clause 4 of each part of IEC 61784-5 provides an overview of the specification of the installation profiles for the relevant CPs; Clause 5 of each part of IEC 61784-5 describes the installation profiles conventions in addition to the basic conventions described in the Introduction of the document; Clause 6 of each part of IEC 61784-5 describes how to express compliance to the installation profiles.

The structure adopted for the parts of the IEC 61784-5 series, where the installation profiles are specified in Annexes having the same clause numbering as IEC 61918, makes it easy to read the profiles in conjunction with IEC 61918 and to immediately realize which requirements are specific of the selected CP.

As far as possible, the specific installation requirements are expressed in terms of references to other International Standards, Technical Specifications, or worldwide-accepted standards as appropriate.

	Heading Level 1	Heading Level 2	Heading Level 3	Annex title	Annex heading Level 1	Annex heading Level 2	Annex heading Level 3
IEC 61918	IEC standard clauses (scope, normative references, terms), and						
	lifecycle						
		Logical sequential work order					
			Common technical installation requirements				
IEC 61784-5 Part <i>n</i> (for CPF <i>n</i> )	IEC standard clause (scope),						
	CPF <i>x</i> Overview, profile conventions, and conformance						
		Not generally specified		Annex A ... Z (normative) CP- or PhL-specific installation profile			
			Not generally specified		IEC standard clauses (scope, normative references, terms) and		
					lifecycle		
						Logical sequential work order	
							Specific technical installation requirements

Figure 9 – Document structure of IEC 61918 and the CPF specific part of IEC 61784-5

**7.7 Communication profiles for wireless communication networks**

Some wireless based communication profiles are specified in IEC 61784-2 by referencing existing standards for wireless PhL and parts of the wireless DLL specifications and combine those with DLL and AL specifications in IEC 61158.

As some of the wireless communication networks have different or at least additional needs as the wired fieldbuses (for example an additional explicit network management), they are specified in different International Standards, for example IEC 62591, IEC 62601 and IEC 62734.

General wireless communication requirements and spectrum considerations are given in IEC/TS 62657-1. Applying wireless communication networks may require additional measures for wireless coexistence management as specified in IEC 62657-2.

## 8 Brief summary of the characteristics of service and protocol for each fieldbus type

### 8.1 Summary of the physical layer service and protocol characteristics

#### 8.1.1 Type 1: media

##### 8.1.1.1 Type 1: Twisted-pair wire media

For twisted-pair wire media, Type 1 specifies two modes of coupling and different signalling speeds as follows:

- a) voltage mode (parallel coupling), 150  $\Omega$ , data rates from 31,25 kbit/s to 25 Mbit/s;
- b) voltage mode (parallel coupling), 100  $\Omega$ , 31,25 kbit/s;
- c) current mode (serial coupling), 1,0 Mbit/s including two current options.

The voltage mode variations may be implemented with inductive coupling using transformers. This is not mandatory if the isolation requirements of this IEC 61158-2 are met by other means.

The Type 1 twisted-pair (or untwisted-pair) wire medium physical layer provides the options:

- no power via the bus conductors; not intrinsically safe;
- power via the bus conductors; not intrinsically safe;
- no power via the bus conductors; intrinsically safe;
- power via the bus conductors; intrinsically safe.

##### 8.1.1.2 Type 1: Optical media

The major variations of the Type 1 optic fiber media are as follows:

- dual fiber mode, data rates from 31,25 kbit/s to 25 Mbit/s;
- single fiber mode, 31,25 kbit/s.

#### 8.1.2 Type 2: Coaxial wire and optical media

Type 2 uses ISO/IEC 8802-3, ISO 11898-1 and ISO 11898-2 and specifies the following variants:

- coaxial copper wire medium, 5 Mbit/s;
- optical fiber medium, 5 Mbit/s;
- network access port (NAP), a point-to-point temporary attachment mechanism that can be used for programming, configuration, diagnostics or other purposes;
- repeater machine sublayers (RM, RRM) and redundant physical layers.

#### 8.1.3 Type 3: Twisted-pair wire and optical media

Type 3 specifies the following synchronous transmission:

- a) twisted-pair wire medium, 31,25 kbit/s, voltage mode (parallel coupling) with the options:
  - power via the bus conductors: not intrinsically safe;
  - power via the bus conductors: intrinsically safe;and the following asynchronous transmission variants:
- b) twisted-pair wire media, up to 12 Mbit/s, ANSI TIA/EIA-485-A;
- c) optical fiber media, up to 12 Mbit/s, with type A4a of IEC 60793-2-40 and type A3c of IEC 60793-2-30.

#### **8.1.4 Type 4: Wire medium**

Type 4 specifies the standard ISO/IEC 8802-3 PhL and wire media with RS-485 wire medium up to 76,8 kbit/s.

#### **8.1.5 Type 5: Wire and optical media**

Type 5 uses the standard ISO/IEC 8802-3 PhL.

#### **8.1.6 Type 6: Not used**

Type 6 is not used.

#### **8.1.7 Type 7: Wire and optical media**

Type 7 specifies the same wire and optical media as Type 1.

#### **8.1.8 Type 8: Twisted-pair wire and optical media**

The physical layer also allows transmitting data units that have been received through a medium access by the transmission medium directly through another medium access and its transmission protocol to another device.

Type 8 specifies the following variants:

- twisted-pair wire medium, up to 16 Mbit/s;
- optical fiber medium, up to 16 Mbit/s.

The general characteristics of these transmission media is full-duplex transmission.

#### **8.1.9 Type 9: Wire and optical media**

Type 9 uses ISO/IEC 8802-3 PhL and see 8.1.1.

#### **8.1.10 Type 10: Wire, optical media and wireless**

Type 10 specifies the PhL according to IEEE 802.3, IEEE 802.11 and IEEE 802.15.4 and additionally optical fiber media according to type A4a of IEC 60793-2-40 and type A3c of IEC 60793-2-30.

#### **8.1.11 Type 11: Wire and optical media**

Type 11 uses the ISO/IEC 8802-3 PhL.

#### **8.1.12 Type 12: Wire and optical media**

Type 12 uses the ISO/IEC 8802-3 PhL with the variant wire medium, 100 Mbit/s, low voltage differential signaling mode (parallel coupling) as specified in ANSI TIA/EIA-644-A.

#### **8.1.13 Type 13: Wire and optical media**

Type 13 uses the ISO/IEC 8802-3 PhL.

#### **8.1.14 Type 14: Wire and optical media**

Type 14 uses ISO/IEC 8802-3 PhL.

**8.1.15 Type 15: Wire and optical media**

Type 15 uses ISO/IEC 8802-3 PhL

**8.1.16 Type 16: Optical media**

Type 16 specifies optical fiber medium, up to 16 Mbit/s.

**8.1.17 Type 17: Wire and optical media**

Type 17 uses the ISO/IEC 8802-3 PhL.

**8.1.18 Type 18 media**

Type 18 specifies the following variants:

- balanced transmission over a 3-core shielded wire medium, up to 10 Mbit/s and 1 200 m;
- balanced transmission over a 4-core unshielded wire medium with network-embedded power distribution, up to 2,5 Mbit/s and 500 m.

**8.1.19 Type 19: Wire and optical media**

Type 19 uses the ISO/IEC 8802-3 PhL.

**8.1.20 Type 20**

Type 20 uses binary phase continuous Frequency Shift Keying (FSK). A relatively high frequency current is superimposed on a low-frequency analog current, which is usually in 4 mA to 20 mA range.

**8.1.21 Type 21: Wire and optical media**

Type 21 uses ISO/IEC 8802-3 PhL.

**8.1.22 Type 22: Wire and optical media**

Type 22 uses ISO/IEC 8802-3 PhL.

**8.1.23 Type 23: Wire and optical media**

Type 23 specifies the standard ISO/IEC 8802-3 PhL.

**8.1.24 Type 24: Twisted-pair wire media**

Type 24 specifies twisted-pair wire medium at 10 Mbit/s and uses the ISO/IEC 8802-3 PhL.

**8.2 Summary of data-link layer service characteristics**

Various distinct types of services are defined in the related IEC 61158-3 series and summarized in this part. Each has a corresponding protocol in a corresponding part of the IEC 61158-4 series. The distinct types of DL-service are:

NOTE 1 Some types do not specify DL-services in IEC 61158. The corresponding type designations are reserved in the IEC 61158-3 series to maintain numbering consistency with other parts and previous editions of IEC 61158.

**Type 1** – A DL-service which provides a superset of those services expected of OSI data-link protocols as specified in ISO/IEC 8886.

**Type 2** – A DL-service which provides both a connected and a connectionless subset of those services specified in ISO/IEC 8886.

**Type 3** – A DL-service which provides a connectionless subset of those services specified in ISO/IEC 8886.

**Type 4** – A DL-service which provides a connectionless subset of those services specified in ISO/IEC 8886.

NOTE 2 The Type 6 DL-service is deleted for lack of market relevance. The designation Type 6 is reserved in the IEC 61158 series to maintain numbering consistency with the other types and previous editions of the IEC 61158 series.

**Type 7** – A DL-service which provides both a connected and a connectionless subset of those services provided by OSI data-link protocols as specified in ISO/IEC 8886.

**Type 8** – A DL-service which provides a connection-oriented subset of those services specified in ISO/IEC 8886.

**Type 11** – A DL-service which provides a connectionless subset of those services specified in ISO/IEC 8886.

**Type 12** – A DL-service which provides a connectionless subset of those services specified in ISO/IEC 8886.

**Type 13** – A DL-service which provides a connectionless subset of those services specified in ISO/IEC 8886.

**Type 14** – A DL-service which provides a connectionless subset of those services specified in ISO/IEC 8886.

**Type 16** – A DL-service which provides a connectionless subset of those services specified in ISO/IEC 8886.

**Type 17** – A DL-service which provides a connectionless subset of those services specified in ISO/IEC 8886.

**Type 18** – A DL-service which provides a connected subset of those services specified in ISO/IEC 8886.

**Type 19** – A DL-service which provides a connectionless subset of those services specified in ISO/IEC 8886.

**Type 21** – A DL-service which provides a connectionless subset of those services specified in ISO/IEC 8886.

**Type 22** – A DL-service which provides both a connected and a connectionless subset of those services specified in ISO/IEC 8886.

**Type 23** – A DL-service which provides a connectionless subset of those services specified in ISO/IEC 8886.

**Type 24** – A DL-service which provides a connectionless subset of those services specified in ISO/IEC 8886.

NOTE 3 Many of these types of service are suitable for use with multiple higher-layer protocols. In addition to the potential ability of these types of data-link service to support different types of fieldbus application layer protocols, it is possible that some of these types of data-link service are also able to support:

- a) the OSI network layer at the boundary between the network and data-link layers of the OSI Basic Reference Model;
- b) the IETF (IP) network layer;



where the scope of addressing is adequate, it is possible that some of these types of data-link service also are able to serve as

- c) an OSI Transport layer service.

### 8.3 Summary of data-link layer protocol characteristics

The fieldbus data-link layer provides basic time-critical messaging communications between devices in an automation environment.

The IEC 61158-4 series defines various distinct and non-interoperable fieldbus data-link protocols, each of which is most closely related to the services of the corresponding part of the IEC 61158-3 series of fieldbus data-link service definitions. The distinct types of DL-protocol are as follows:

NOTE 1 Some types do not specify DL-protocols in IEC 61158. The corresponding type designations are reserved in the IEC 61158-4 series to maintain numbering consistency with other parts and previous editions of IEC 61158.

**Type 1** – A DL-protocol for the Type 1 DL-service. The maximum system size is 56k links of 232 nodes, each with 240 DLSAP-addresses and related peer and publisher DLCEPs, plus another 768 link-wide group DL-addresses per link, plus another 256 DLSAP-addresses and 2816 peer and publisher DLCEPs per link which can be allocated among the link's nodes, plus  $2^{27}$  group DL-addresses for the extended link. Fewer links or nodes permit an increase in the number of DLSAP-addresses and related DLCEPs.

**Type 2** – A DL-protocol for the Type 2 DL-service. The maximum system size is an unlimited number of links of 99 nodes, each with 255 DLSAP-addresses. Each link has a maximum of  $2^{24}$  related peer and publisher DLCEPs.

**Type 3** – A DL-protocol for the Type 3 DL-service. The maximum system size is an unlimited number of links of 127 nodes, each with 66 DLSAP-addresses.

**Type 4** – A DL-protocol for the Type 4 DL-service. The maximum system size is a virtually unlimited number of links, each with 125 nodes.

NOTE 2 The Type 6 is deleted for lack of market relevance. The designation Type 6 is reserved in the IEC 61158 series to maintain numbering consistency with the other types and previous editions of the IEC 61158 series.

**Type 7** – A DL-protocol for the Type 7 DL-service. The maximum system size is 126 links of 256 nodes, each with 16 DLSAP-addresses and 16 group DL-addresses, plus another 28k DLSAP-addresses and related peer and publisher DLCEPs per link which can be allocated among the link's nodes, plus another 28k link-wide group DL-addresses per link, plus  $2^{23}$  group DL-addresses for the extended link.

**Type 8** – A DL-protocol for the Type 8 DL-service. The maximum system size is 1 link of 256 nodes with preconfigured DLCEPs.

**Type 11** – A DL-protocol for the Type 11 DL-service. The maximum system size is a single link of 254 nodes, with 4 096 peer and publisher DLCEPs which can be allocated among the link's nodes.

**Type 12** – A DL-protocol for the Type 12 DL-service. The maximum system size is an unlimited number of segments of  $2^{16}$  nodes each. Each node has a maximum of  $2^{16}$  related peer and publisher/subscriber DLCEPs.

**Type 13** – A DL-protocol for the Type 13 DL-service. The maximum system size is a single link with 254 DLSAP-addresses. Each node has a maximum number of 254 related peer and 254 publisher/subscriber DLCEPs.

**Type 14** – A DL-protocol for the Type 14 DL-service. The maximum system size is an unlimited number of micro-segments of 254 nodes. Each node has a maximum of  $2^{16}$  related peer and publisher/subscriber DLCEPs

**Type 16** – A DL-protocol for the Type 16 DL-service. The maximum system size is 1 link with 254 DLSAP-addresses.

**Type 17** – A DL-protocol for the Type 17 DL-service. The maximum system size is 31 links of 64 nodes with preconfigured DLCEPs.

**Type 18** – A DL-protocol for the Type 18 DL-service. The maximum system size is 1 link with 128 DLSAP-addresses.

**Type 19** – A DL-protocol for the Type 19 DL-service layered on ISO/IEC 8802-3.

**Type 21** – A DL-protocol for the Type 21 DL-service. The maximum system size is 1 link with 255 DLSAP-addresses.

**Type 22** – A DL-protocol for the Type 22 DL-service. The maximum system size is  $2^{14}$  nodes with a total of  $2^{24}$  DLSAP-addresses.

**Type 23** – A DL-protocol for the Type 23 DL-service layered on ISO/IEC 8802-3.

**Type 24** – A DL-protocol for the Type 24 DL-service. The maximum system size is 1 link with 62 DLSAP-addresses.

NOTE 3 Use of some of the associated protocol types is restricted by their copyright holders. In all cases it is possible to use a particular data-link layer protocol type without restriction when coupled with the same Type physical layer and application layer protocols, or with other combinations as specified in the IEC 61784 series. Use of the various protocol types in other combinations requires permission of their respective copyright holders.

#### 8.4 Summary of application layer service characteristics

FAL services and protocols are provided by FAL application-entities (AE) contained within the application processes. The FAL AE is composed of a set of object-oriented application service elements (ASEs) and a layer management entity (LME) that manages the AE. The ASEs provide communication services that operate on a set of related application process object (APO) classes. One of the FAL ASEs is a management ASE that provides a common set of services for the management of the instances of FAL classes.

Although these services specify, from the perspective of applications, how request and responses are issued and delivered, they do not include a specification of what the requesting and responding applications are to do with them. That is, the behavioral aspects of the applications are not specified; only a definition of what requests and responses they can send/receive is specified. This permits greater flexibility to the FAL users in standardizing such object behavior. In addition to these services, some supporting services are also defined in the type specific parts of IEC 61158-5 to provide access to the FAL to control certain aspects of its operation.

Various models of communications are specified in the related type specific parts of IEC 61158-5 and summarized in this part of IEC 61158. Each model is specified as a distinct communication “Type”. Each type has a corresponding protocol in the type specific part of IEC 61158-6. The distinct types of AL-service are as follows:

NOTE The Type 1 and Type 6 application services are deleted for lack of market relevance. The designations Type 1 and Type 6 are reserved in the IEC 61158-5 series to maintain numbering consistency with the other types and previous editions of IEC 61158.

**Type 2** – An application service which provides three main types of ASEs for FAL users, accessed using either one unconnected AR or one of four connection-based ARs.

**Type 3** – An application service which provides access to two types of connection-based AR definitions for three types of FAL users (master class 1, master class 2, and slave types).

**Type 4** – An application service that provides access to one type of connection-less FAL AE, providing a set of ASE service primitives, divided into AR ASE service primitives and REP ASE service primitives.

**Type 5** – An application service that adapts Type 9 services to be used over socket-based connection-oriented and connectionless services. Typical applications of Type 5 use TCP and UDP.

**Type 7** – an application service which provides six types of ASEs for FAL users, accessed using either a predefined or a negotiated or an ad hoc AR.

**Type 8** – An application service with five ASEs providing access to two types of connection-based and one connectionless AR Application service elements for two FAL user types (master and slave).

**Type 9** – An application service which adapts ISO 9506 (MMS) for use over the Type 1 data-link layer.

**Type 10** – An application service which provides access to four types of connection-based AR definitions for three types of FAL users (IO supervisor, IO controller and IO device types).

**Type 11** – An application service which provides unconfirmed one-to-many publisher/subscriber ARs.

**Type 12** – An application service which provides connectionless cyclic exchange of data and for spontaneous communication for different ASEs.

**Type 13** – An application service which provides four ASEs for FAL users using connection-oriented confirmed and connectionless unconfirmed ARs.

**Type 14** – An application service which provides access to three types of object-oriented ASEs (application access, socket mapping and FAL management) for FAL users.

**Type 15** – An application service which provides two communications models, one providing one type of ASE and two types of AR, the other providing one type of ASE and one type of AR.

**Type 16** – An application service which provides three ASEs for FAL users, accessed using two types of ARs.

**Type 17** – An application service which provides access to 6 types of ASEs (variable, event, load region, function invocation, time and network management ASEs) for FAL users.

**Type 18** – An application service which provides access to 4 types of connection-based AR definitions for 2 types of FAL users (master and slave types) to access the 2 classes of type 18 DLE.

**Type 19** – An application service which provides three ASEs for FAL users, accessed using three types of ARs.

**Type 20** – An application service which provides two ASEs for FAL users, using a single type of AR.

**Type 21** – An application service which provides four ASEs for FAL users, accessed using three types of ARs.

**Type 22** – An application service for connectionless cyclic exchange of data and for connection-oriented communication for different ASEs.

**Type 23** – An application service which provides six ASEs for FAL users, accessed using two types of ARs.

**Type 24** – An application service which provides three ASEs for FAL users, accessed using two types of ARs.

## 8.5 Summary of application layer protocol characteristics

The fieldbus application layer (FAL) is an application layer communication standard designed to support the conveyance of time-critical application requests and responses among devices in an automation environment. The term “time-critical” is used to represent the presence of a time-window, within which one or more specified actions are required to be completed with some defined level of certainty. Failure to complete specified actions within the time window risks failure of the applications requesting the actions, with attendant risk to equipment, plant and possibly human life.

The type specific parts of IEC 61158-6 specify interactions between remote applications in terms of

- the encoding rules that are applied to all the application layer protocol data units (APDUs);
- the formal abstract syntax definitions of such APDUs;
- the protocol state machine descriptions that handle the APDUs and the primitives in the correct sequences;
- the mappings of the APDUs to and from the data-link layer services defined in IEC 61158-3.

The FAL encoding rules are designed assuming that both the encoder (sender) and the decoder (receiver) have the common knowledge of the abstract syntax. Wherever possible, data types identifiers are not encoded and transferred over the network.

NOTE 1 This is why the Abstract Syntax Notation One / Basic Encoding Rule is not practical for the FAL.

The purpose of the type specific parts of IEC 61158-6 is to define the protocol provided to

- the fieldbus data-link layer at the boundary between the application and data-link layers of the fieldbus reference model, and
- the system management at the boundary between the system management and application layers of the fieldbus reference model.

A type specific part of IEC 61158-6 defines the application layer protocol, which corresponds to the application layer service definitions specified in the type specific part of IEC 61158-5.

Although it may be possible to use different types of protocols on the same network provided that the underlying lower layers are compatible, this specification does not assure such interoperability among different types.

The various communications protocols are specified in the type specific parts of IEC 61158-6 parts and summarized in this part of IEC 61158. Each protocol is specified as a distinct communication “Type”. Each has a corresponding service definition in a corresponding type specific part of IEC 61158-5. The different types of AL-protocol are as follows:

NOTE 2 The Type 1 and Type 6 application protocols are deleted for lack of market relevance. The designations Type 1 and Type 6 are reserved in the IEC 61158-6 series to maintain numbering consistency with the other types and previous editions of IEC 61158.

**Type 2** – An application protocol which specifies abstract syntax, coding and behavior of the type 2 application service elements.

**Type 3** – An application protocol which specifies abstract syntax, coding and behavior of the type 3 application service elements.

**Type 4** – An application protocol which provides state machines for decoding the information stored in the APDU, and a DLL Mapping Protocol Machine, handling the interface to the DLL.

**Type 5** – An application protocol that provides for high-performance transfers of Type 5 services by using fixed format messages that can be configured for 4- or 8-octet boundary alignment.

**Type 7** – An application protocol which specifies abstract syntax, coding and behavior of the type 7 application service elements.

**Type 8** – An application protocol which specifies abstract syntax, coding and behavior of the type 8 application service elements.

**Type 9** – An application protocol that has been optimized for the transfer of Type 9 services over the limited-data-rate Type 1 data-link layer.

**Type 10** – An application protocol which specifies abstract syntax, coding and behavior of the type 10 application service elements.

**Type 11** – An application protocol which provides unconfirmed one-to-many publisher/subscriber ARs on the pre-established AREPs.

**Type 12** – An application protocol which specifies abstract syntax, coding and behavior of the type 12 application service elements.

**Type 13** – An application protocol which specifies abstract syntax, coding and behavior of the type 13 application service elements.

**Type 14** – An application protocol which specifies object definitions, abstract syntax, coding and behavior of the type 14 application service elements.

**Type 15** – An application protocol which specifies abstract syntax, coding and behavior of the type 15 application service elements.

**Type 16** – An application protocol which specifies abstract syntax, coding and behavior of the type 16 application service elements.

**Type 17** – An application protocol which provides communication between ASEs using five types of AR with four types of role (client, server, publisher and subscriber types).

**Type 18** – An application protocol which provides four types of connection-based AR definitions for two types of FAL users (master and slave types) to access the two classes of a type 18 DLE.

**Type 19** – An application protocol which specifies abstract syntax, coding and behavior of the type 19 application service elements.

**Type 20** – An application protocol which specifies abstract syntax, coding and behavior of the type 20 application service elements.

**Type 21** – An application protocol which specifies abstract syntax, coding and behavior of the type 21 application service elements.

**Type 22** – An application protocol which specifies abstract syntax, coding and behavior of the type 22 application service elements.

**Type 23** – An application protocol which specifies abstract syntax, coding and behavior of the type 23 application service elements.

**Type 24** – An application protocol which specifies abstract syntax, coding and behavior of the type 24 application service elements.

NOTE 3 Use of some of these protocol types is restricted by their copyright holders. In all cases it is possible to use a particular application layer protocol Type without restriction when coupled with the same type physical layer and data-link layer protocols, or with other combinations as specified in IEC 61784-1 and IEC 61784-2. Use of the various protocol types in other combinations requires permission of their respective copyright holders.

## 9 Application layer service description concepts

### 9.1 Overview

The fieldbus is intended to be used in factories and process plants to interconnect primary automation devices (e.g. sensors, actuators, local display devices, annunciators, programmable logic controllers, small single loop controllers, and stand-alone field controls) with control and monitoring equipment located in control rooms.

Primary automation devices are associated with the lowest levels of the industrial automation hierarchy and perform a limited set of functions within a definite time window. Some of these functions include diagnostics, data validation, and handling of multiple inputs and outputs.

These primary automation devices, also termed field devices, are located close to the process fluids, the fabricated part, the machine, the operator and the environment. This use positions the fieldbus at the lowest levels of the computer integrated manufacturing (CIM) architecture.

Some of the expected benefits in using fieldbus are reduction in wiring, increase in amount of data exchanged, wider distribution of control between the primary automation devices and the control room equipment, and the satisfaction of time critical constraints.

Subclauses 9.2 through 9.9 describe fundamentals of the FAL. Detailed descriptive information about each of the FAL ASEs can be found in the “overview” subclause of each of the communication model specifications.

### 9.2 Architectural relationships

#### 9.2.1 Relationship to the application layer of the OSI Basic Reference Model

The functions of the FAL have been described according to OSI layering principles. However, its architectural relationship to the lower layers is different, as shown in Figure 10.

- The FAL includes OSI functions together with extensions to cover time-critical requirements. The OSI application layer structure standard (ISO/IEC 9545) was used as a basis for specifying the FAL.
- The FAL directly uses the services of the underlying layer. The underlying layer may be the data-link layer or any layer in between. When using the underlying layer, the FAL may provide functions normally associated with the OSI middle layers for proper mapping onto the underlying layer.

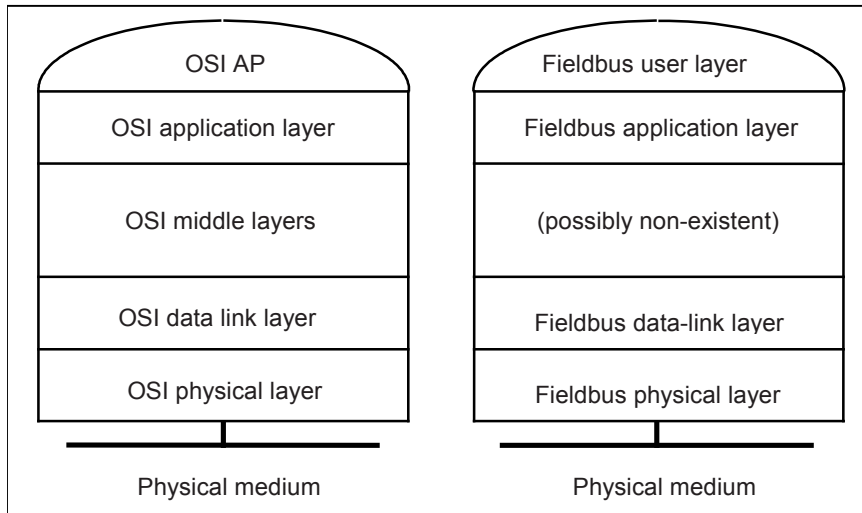

**Figure 10 – Relationship to the OSI Basic Reference Model**

**9.2.2 Relationships to other fieldbus entities**

**9.2.2.1 General**

The fieldbus application layer (FAL) architectural relationships, as illustrated in Figure 11, have been designed to support the interoperability needs of time-critical systems distributed within the fieldbus environment.

Within this environment, the FAL provides communications services to time-critical and non-time-critical applications located in fieldbus devices.

In addition, the FAL directly uses the data-link layer to transfer its application layer protocol data units. It does this using a set of data transfer services and a set of supporting services used to control the operational aspects of the data-link layer.

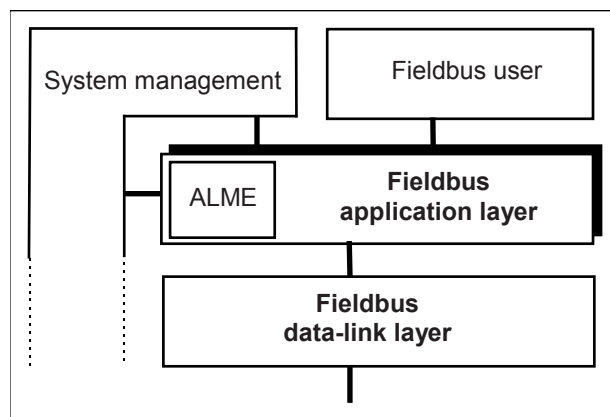

**Figure 11 – Architectural positioning of the fieldbus application layer**

**9.2.2.2 Use of the fieldbus data-link layer**

The fieldbus application layer (FAL) provides network access to fieldbus APs. It interfaces directly to the fieldbus data-link layer for transfer of its APDUs.

The data-link layer provides various types of services to the FAL for the transfer of data between data-link endpoints (e.g. DLSAPs, DLCEPs).



### 9.2.2.3 Support for fieldbus applications

Fieldbus applications are represented to the network as application processes (APs). APs are the components of a distributed system that may be individually identified and addressed.

Each AP contains an FAL application entity (AE) that provides network access for the AP. That is, each AP communicates with other APs through its AE. In this sense, the AE provides a window of visibility into the AP.

APs contain identifiable components that are also visible across the network. These components are represented to the network as application process objects (APO). They may be identified by one or more key attributes. They are located at the address of the application process that contains them.

The services used to access them are provided by APO-specific application service elements (ASEs) contained within the FAL. These ASEs are designed to support user, function block, and management applications.

### 9.2.2.4 Support for system management

The FAL services can be used to support various management operations, including management of fieldbus systems, applications, and of the fieldbus.

### 9.2.2.5 Access to FAL layer management entities

One layer management entity (LME) may be present in each FAL entity on the network. FALMEs provide access to the FAL for system management purposes.

The set of data accessible by the system manager is referred to as the system management information base (SMIB). Each fieldbus application layer management entity (FALME) provides the FAL portion of the SMIB. How the SMIB is implemented is beyond the scope of the IEC 61158-5 series.

## 9.3 Fieldbus application layer structure

### 9.3.1 Overview

The structure of the FAL is a refinement of the OSI application layer structure (ISO/IEC 9545). As a result, the organization of 9.3 is similar to that of ISO/IEC 9545. Certain concepts presented in 9.3 have been refined from ISO/IEC 9545 for the fieldbus environment.

The FAL differs from the other layers of the OSI Basic Reference Model in the following two principal aspects.

- The OSI Basic Reference Model defines a single type of application layer communications channel, the association, to connect APs to each other. The FAL defines the application relationship (AR), of which there are several types, to permit application processes (APs) to communicate with each other.
- The FAL uses the DLL to transfer its APDUs and not the OSI presentation layer. Therefore, there is no explicit presentation context available to the FAL. Between the same pair (or set) of data-link service access points the FAL protocol may not be used concurrently with other application layer protocols.

### 9.3.2 Fundamental concepts

The operation of time-critical real open systems is modeled in terms of interactions between time-critical APs. The FAL permits these APs to pass commands and data between them.



Cooperation between APs requires that they share sufficient information to interact and carry out processing activities in a coordinated manner. Their activities may be restricted to a single fieldbus segment, or they may span multiple segments. The FAL has been designed using a modular architecture to support the messaging requirements of these applications.

Cooperation between APs also sometimes requires that they share a common sense of time. The FAL or the data-link layer (parts of the IEC 61158-3 series and parts of the IEC 61158-4 series) may provide for the distribution of time to all devices. They also may define local device services that can be used by APs to access the distributed time.

Subclauses 9.3.3 through 9.3.7 describe each of the modular components of the architecture and their relationships with each other. The components of the FAL are modeled as objects, each of which provides a set of FAL communication services for use by applications. The FAL objects and their relationships are described below. The detailed specifications of FAL objects and their services are provided in the IEC 61158-5 series. The IEC 61158-6 series specifies the protocols necessary to convey these object services between applications.

### **9.3.3 Fieldbus application processes**

#### **9.3.3.1 Definition of the fieldbus AP**

In the fieldbus environment, an application may be partitioned into a set of components and distributed across a number of devices on the network. Each of these components is referred to as a fieldbus application process (AP). A fieldbus AP is a variation of an application process as defined in ISO OSI Reference Model (ISO/IEC 7498-1). Fieldbus APs may be unambiguously addressed by at least one individual data-link layer service access point address. Unambiguously addressed, in this context, means that no other AP may simultaneously be located by the same address. This definition does not prohibit an AP from being located by more than one individual or group data-link service access point address.

#### **9.3.3.2 Communication services**

Fieldbus APs communicate with each other using confirmed and unconfirmed services (ISO/IEC 10731). The services defined for the FAL specify the semantics of the services as seen by the requesting and responding APs. The syntax of the messages used to convey the service requests and responses is defined in the IEC 61158-6 series. The AP behavior associated with the services is specified by the AP.

Confirmed services are used to define request/response exchanges between APs.

Unconfirmed services, in contrast, are used to define the unidirectional transfer of messages from one AP to one or more remote APs. From a communications perspective, there is no relationship between separate invocations of unconfirmed services as there is between the request and response of a confirmed service.

#### **9.3.3.3 AP interactions**

##### **9.3.3.3.1 General**

Within the fieldbus environment, APs may interact with other APs as necessary to achieve their functional objectives. No constraints are imposed by this part of IEC 61158 on the organization of these interactions or the possible relationships that may exist between them.

For example, in the fieldbus environment, interactions may be based on request/response messages sent directly between APs, or on data/events sent by one AP for use by others. These two models of interactions between APs are referred to as client/server and publisher/subscriber interactions.

The services supported by an interaction model are conveyed by application relationship endpoints (AREPs) associated with the communicating APs. The role that the AREP plays in

the interaction (e.g. client, server, peer, publisher, subscriber) is defined as an attribute of the AREP.

### 9.3.3.3.2 Client/server interactions

Client/server interactions are characterized by a bi-directional data flow between a client AP and one or more server APs. Figure 12 illustrates the interaction between a single client and a single server. In this type of interaction, the client may issue a confirmed or unconfirmed request to the server to perform some task. If the service is confirmed then the server will always return a response. If the service is unconfirmed, the server may return a response using an unconfirmed service defined for this purpose.

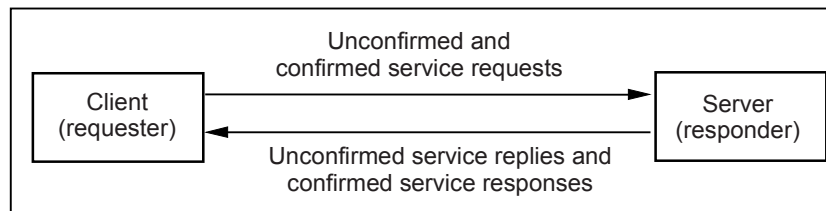

Figure 12 – Client/server interactions

### 9.3.3.3.3 Publisher/subscriber interactions

#### 9.3.3.3.3.1 General

Publisher/subscriber interactions, on the other hand, involve a single publisher AP and a group of one or more subscriber APs. This type of interaction has been defined to support variations of two models of interaction between APs, the "pull" model and the "push" model. In both models, the setup of the publishing AP is performed by management and is outside the scope of the IEC 61158-5 series and the IEC 61158-6 series.

#### 9.3.3.3.3.2 Pull model interactions

In the "pull" model, the publisher receives a request to publish from a remote publishing manager, and broadcasts (or multicasts) its response across the network. The publishing manager is responsible only for initiating publishing by sending a request to the publisher.

Subscribers wishing to receive the published data listen for responses transmitted by the publisher. In this fashion, data is "pulled" from the publisher by requests from the publishing manager.

Confirmed FAL services are used to support this type of interaction. Two characteristics of this type of interaction differentiate it from the other types of interaction. First, a typical confirmed request/response exchange is performed between the publishing manager and the publisher. However, the underlying conveyance mechanism provided by the FAL returns the response not just to the publishing manager, but also to all subscribers wishing to receive the published information. This is accomplished by having the data-link layer transmit the response to a group address, rather than to the individual address of the publishing manager. Therefore, the response sent by the publisher contains the published data and is multicast to the publishing manager and to all subscribers.

The second difference occurs in the behavior of the subscribers. Pull model subscribers, referred to as pull subscribers, are capable of accepting published data in confirmed service responses without having issued the corresponding request. Figure 13 illustrates these concepts.

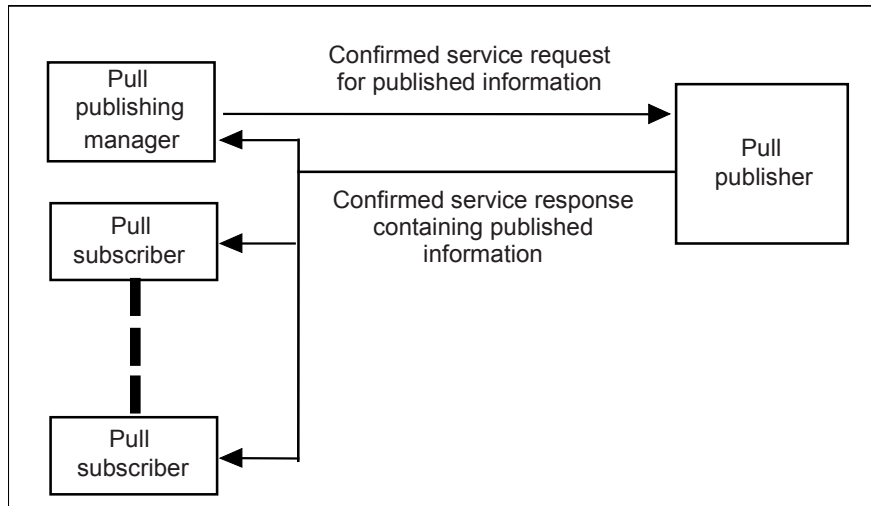

Figure 13 – Pull model interactions

9.3.3.3.3 Push model interactions

In the "push" model, two services may be used, one confirmed and one unconfirmed. The confirmed service is used by the subscriber to request to join the publishing. The response to this request is returned to the subscriber, following the client/server model of interaction. This exchange is only necessary when the subscriber and the publisher are located in different APs.

The unconfirmed service used in the push model is used by the publisher to distribute its information to subscribers. In this case, the publisher is responsible for invoking the correct unconfirmed service at the appropriate time and for supplying the appropriate information. In this fashion, it is configured to "push" its data onto the network.

Subscribers for the push model receive the published unconfirmed services distributed by publishers. Figure 14 illustrates the concept of the push model.

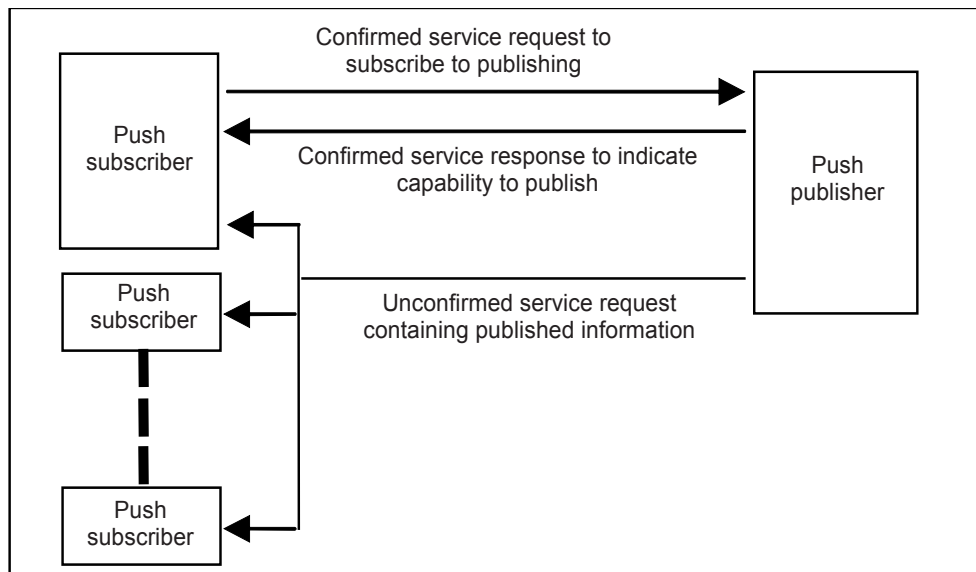

Figure 14 – Push model interactions

#### 9.3.3.3.4 Timeliness of published information

To support the perishable nature of published information, the FAL may support four types of timeliness defined for publisher/subscriber interactions. Each makes it possible for subscribers of published data to determine if the data they are receiving is up-to-date or “stale”. These types are realized through mechanisms within the data-link layer (DLL). Each is described briefly in Table 3. For a more detailed description, refer to parts of the IEC 61158-3 series and parts of the IEC 61158-4 series.

**Table 3 – Types of timeliness defined for publisher/subscriber interactions**

Type	Description
Transparent	This type of timeliness allows the user application process to determine the timeliness quality of the data that it generates and have the timeliness quality accompany the information when it is transferred across the network. In this type of timeliness, the network provides no computation or measurement of timeliness. It merely conveys the timeliness quality provided with the data by the user application process.
Residence	When the FAL submits data from the publishing AP to the DLL for transmission, the DLL starts a timer. If the timer expires before the data has been transmitted, the DLL marks the buffer as “not timely” and conveys this timeliness information with the data.
Synchronized	This type of timeliness requires the coordination of two pieces of published information. One is the data to be published and the other is a special “sync mark”. When the sync mark is received from the network a timer starts in each of the participating stations. Subsequently, when data is received for transmission by the DLL at the publishing station, or when the transmitted data is received from the network at a subscribing station, the DLL timeliness attribute for the data is set to TRUE. It remains TRUE until the reception of the next sync mark or until the timer expires. Data received after the timer expires but before the next sync mark does not cause the timeliness attribute to be reset to TRUE. It is only reset to TRUE if data is received within the time window after receipt of the sync mark. Data transmitted by the publisher station with the timeliness attribute set to FALSE maintains the setting of FALSE at each of the subscribers, regardless of their timer operation.
Update	This type of timeliness requires the coordination of the same two pieces of published information defined for <i>synchronized</i> timeliness. In this type, the sync mark also starts a timer in each of the participating stations. Like <i>synchronized</i> timeliness, expiration of the timer always causes the timeliness attribute to be set to FALSE. Unlike <i>synchronized</i> timeliness, receipt of new data at any time (not just within the time window started with the receipt of a sync mark) causes the timeliness attribute to be set to TRUE.

#### 9.3.3.4 AP structure

The internals of APs may be represented by one or more application process objects (APOs) and accessed through one or more application entities (AEs). AEs provide the communication capabilities of the AP. For each fieldbus AP, there is one and only one FAL AE. APOs are the network representation of application-specific capabilities (user application process objects) of an AP that are accessible through its FAL AE.

#### 9.3.3.5 AP class

An AP class is a definition of the attributes and services of an AP. The standard class definitions for APs are defined in the parts of the IEC 61158-5 series. User defined classes also may be specified. Class identifiers (described in Clause 3 of the parts of the IEC 61158-5 series) are assigned from a set reserved for this purpose.

#### 9.3.3.6 AP type

APs are defined by instantiating an AP class. Each AP definition is composed of the attributes and services selected for the AP from those defined by its AP class. In addition, an AP definition contains values for one or more of the attributes selected for it. When two APs share the same definition, that definition is referred to as an AP type. Thus, an AP type is a generic specification of an AP that may be used to define one or more APs.

### 9.3.4 Application process objects

#### 9.3.4.1 Definition of APO

An application process object (APO) is a network representation of a specific aspect of an AP. Each APO represents a specific set of information and processing capabilities of an AP that are accessible through services of the FAL. APOs are used to represent these capabilities to other APs in a fieldbus system.

From the perspective of the FAL, an APO is modeled as a network accessible object contained within an AP or within another APO (APOs may contain other APOs). APOs provide the network definition for objects contained within an AP that are remotely accessible. The definition of an APO includes an identification of the FAL services that can be used by remote APs for remote access. The FAL services, as shown in Figure 15, are provided by the FAL communications entity of the AP, known as the FAL applications entity (FAL AE).

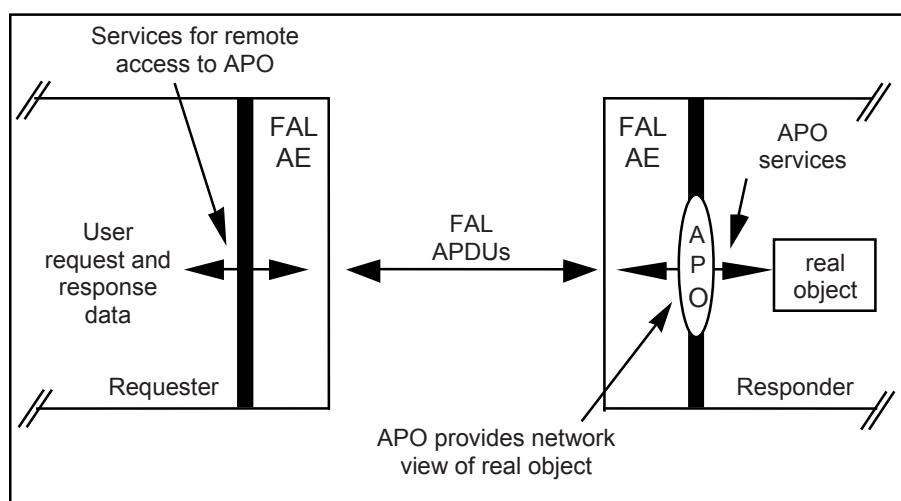

**Figure 15 – APOs services conveyed by the FAL**

In Figure 15, remote APs acting as clients may access the real object by sending requests through the APO that represents the real object. Local aspects of the AP convert between the network view (the APO) of the real object and the internal AP view of the real object.

To support the publisher/subscriber model of interaction, information about the real object can be published through its APO. Remote APs acting as subscribers see the APO view of the published information instead of having to know any of the real object specific details.

#### 9.3.4.2 APO classes

An APO class is a generic specification for a set of APOs, each of which is described by the same set of attributes and accessed using the same set of services.

APO classes provide the mechanism for standardizing network visible aspects of APs. Each standard APO class definition specifies a particular set of network accessible AP attributes and services. The IEC 61158-6 series specifies the syntax and the procedures used by the FAL protocol to provide remote access to the attributes and services of an APO class.

Standard APO classes are specified by this part of IEC 61158 for the purpose of standardizing remote access to APs. User-defined classes may also be specified.

User defined classes are defined as subclasses of standardized APO classes or of other user-defined classes. They may be defined by identifying new attributes or by indicating that optional attributes for the parent class are mandatory for the subclass. The conventions for

defining classes, specified in the type specific parts of IEC 61158-5 series, may be used for this purpose. The method for registering or otherwise making these new class definitions available for public use is beyond the scope of this part of IEC 61158.

#### **9.3.4.3 APOs as instances of APO classes**

APO classes are defined in this part of IEC 61158 using templates. These templates are used not only to define APO classes, but also to specify the instances of a class.

Each APO defined for an AP is an instance of an APO class. Each APO provides the network view of a real object contained in an AP. An APO is defined by:

- a) selecting the attributes from its APO class template that are to be accessible from the real object;
- b) assigning values to one or more attributes indicated as key in the template. Key attributes are used to identify the APO;
- c) assigning values to zero, one, or more non-key attributes for the APO. Non-key attributes are used to characterize the APO;
- d) selecting the services from the template that may be used by remote APs to access the real object.

The type specific parts of the IEC 61158-5 series specify the conventions for class templates. These conventions provide for the definition of mandatory, optional, and conditional attributes and services.

Mandatory attributes and services are required to be present in all APOs of the class. Optional attributes and services may be selected, on an APO-by-APO basis, for inclusion in an APO. Conditional attributes and services are defined with an accompanying constraint statement. Constraint statements specify the conditions that indicate whether or not the attribute is to be present in an APO.

#### **9.3.4.4 APO types**

APO types provide the mechanism for defining standard APOs.

APOs are defined by instantiating an APO class. Each APO definition is composed of the attributes and services selected for the APO from those defined by its APO class. In addition, an APO definition contains values for one or more of the attributes selected for it. When two APOs share the same definition, except for the key attribute settings, that definition is referred to as an APO type. Thus, an APO type is a generic specification of an APO that may be used to define one or more APOs.

### **9.3.5 Application entities**

#### **9.3.5.1 Definition of FAL AE**

An application entity provides the communication capabilities for a single AP. An FAL AE provides a set of services and the supporting protocols to enable communications between APs in a fieldbus environment. The services provided by FAL AEs are grouped into application service elements (ASE), such that the FAL services provided to an AP are defined by the ASEs its FAL AE contains. Figure 16 illustrates this concept.

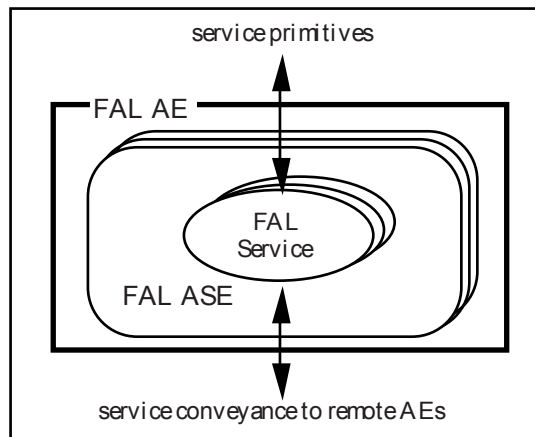

**Figure 16 – Application entity structure**

### 9.3.5.2 AE type

Application entities that provide the same set of ASEs are of the same AE-type. Two AEs that share a common set of ASEs are capable of communicating with each other.

### 9.3.6 Fieldbus application service elements

#### 9.3.6.1 General

An application service element (ASE), as defined in ISO/IEC 9545, is a set of application functions that provide a capability for the interworking of application-entity-involutions for a specific purpose. ASEs provide a set of services for conveying requests and responses to and from application processes and their objects. AEs, as defined above, are represented by a collection of ASE involutions within the AE.

#### 9.3.6.2 FAL services

FAL services convey functional requests/responses between APs. Each FAL service is defined to convey requests and responses for access to a real object modeled as an FAL accessible object.

The FAL defines both confirmed and unconfirmed services. Confirmed service requests are sent to the AP containing the real object.

An invocation of a confirmed service request may specify an AL-user supplied InvokeID. When present, this InvokeID is returned in the resulting local service confirmation to that AL-user. Confirmed service request APDUs and associated reply APDUs carry a RequestID that permits the correlation of the two APDUs. In some implementations the AL-user-provided InvokeID may serve as that RequestID. Similarly, confirmed service indication primitives and associated response primitives carry a locally-formed IndicationID that permits the correlation of the two primitives. In some implementations the received RequestID, coupled with the FAL address of the requesting FAL AE, may serve as that IndicationID.

Unconfirmed services may be sent from the AP containing the real object to send information about the object. They also may be sent to the AP containing the real object to access the real object. Both types of unconfirmed services may be defined for the FAL.

#### 9.3.6.3 Definition of FAL ASEs

##### 9.3.6.3.1 General

A modular approach has been taken in the definition of FAL ASEs. The ASEs defined for the FAL are also object-oriented. In general, ASEs provide a set of services designed for one



specific object class or for a related set of classes. Common object management ASEs, when present, provide a common set of management services applicable to all classes of objects.

To support remote access to the AP, the Application Relationship ASE is defined. It provides services to the AP for defining and establishing communication relationships with other APs, and it provides services to the other ASEs for conveying their service requests and responses.

Each FAL ASE defines a set of services, APDUs, and procedures that operate on the classes that it represents. Only a subset of the ASE services may be provided to meet the needs of an application. Profiles may be used to define such subsets. Definition of profiles is beyond the scope of this part of IEC 61158.

APDUs are sent and received between FAL ASEs that support the same services. Each FAL AE contains, at a minimum, the AR ASE and at least one other ASE. Figure 17 illustrates an example set of the FAL ASEs and their architectural relationships. All APO ASEs follow this example.

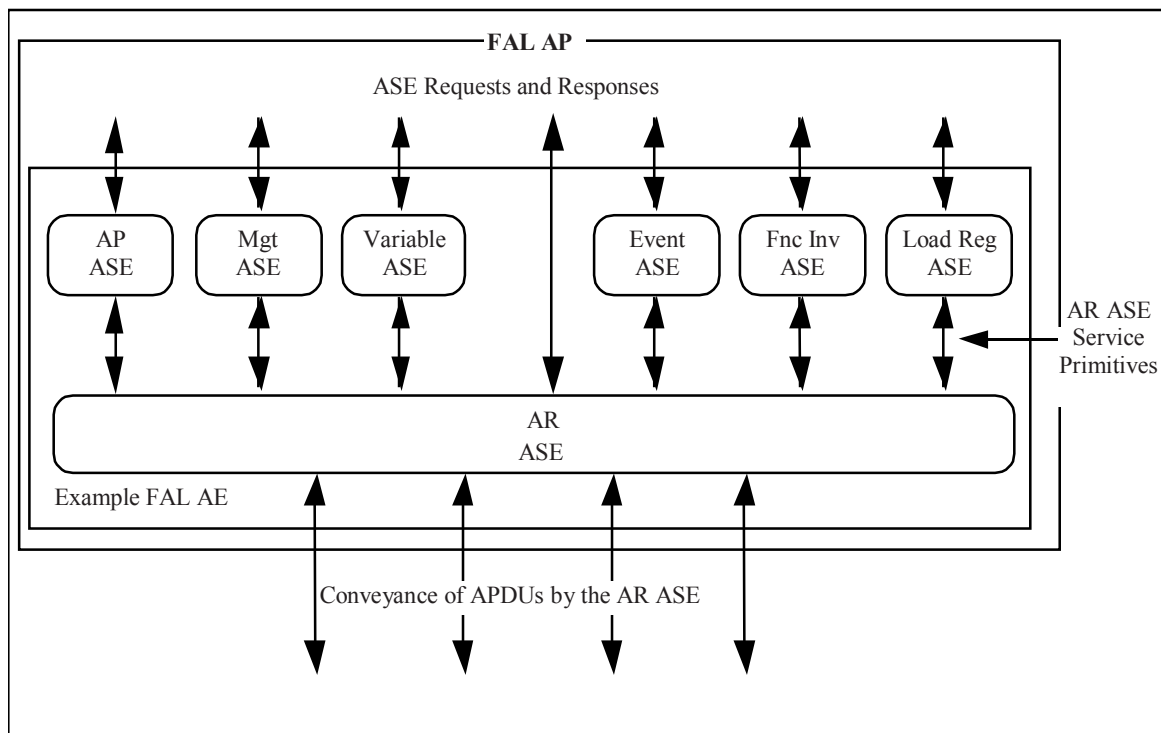
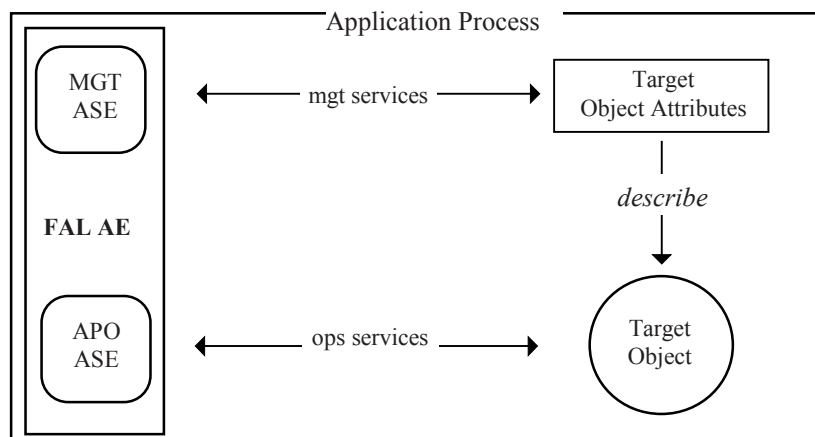

Figure 17 – Example FAL ASEs

### 9.3.6.3.2 Object-management ASE

A special object-management ASE may be specified for the FAL to provide services for the management of objects. Its services are used to access object attributes, and create and delete object instances. These services are used to manage network visible AP objects accessed through the FAL. The specific operational services that apply to each object type are specified in the definition of the ASE for the object type. Figure 18 illustrates the integration of management and operational services for an object within an AP.





**Figure 18 – FAL management of objects**

#### **9.3.6.3.3 AP ASE**

An AP ASE may be specified for the identification and control of FAL APs. The attributes defined by the AP ASE specify characteristics of the AP about its manufacturer and list its contents and capabilities.

#### **9.3.6.3.4 APO ASEs**

The FAL specifies a set of ASEs with services defined for accessing the APOs of an AP. The APO ASEs defined for the FAL are defined by each communication model.

#### **9.3.6.3.5 AR ASE**

An AR ASE is specified to establish and maintain application relationships (ARs) that are used to convey FAL APDUs between/among APs. ARs represent application layer communication channels between APs. AR ASEs are responsible for providing services at the endpoints of ARs. AR ASE services may be defined for establishing, terminating, and aborting ARs, for conveying APDUs for the AE, and for indicating the local status of the AR to the user. In addition, local services may be defined for accessing certain aspects of AR endpoints.

#### **9.3.6.4 FAL service conveyance**

FAL APO ASEs provide services to convey requests and responses between service users and real objects.

To accomplish the task of conveying service requests and responses, three types of activities for the sending user and three corresponding types for the receiving user are defined. At the sending user, they accept service requests and responses to be conveyed. Second, they select the type of FAL APDU that will be used to convey the request or response and encode the service parameters into its body portion. Then they submit the encoded APDU body to the AR ASE for conveyance.

At the receiving user, they receive encoded APDU bodies from the AR ASE. They decode the APDU bodies and extract the service parameters conveyed by them. To conclude the conveyance, they deliver the service request or response to the user. Figure 19 illustrates these concepts.

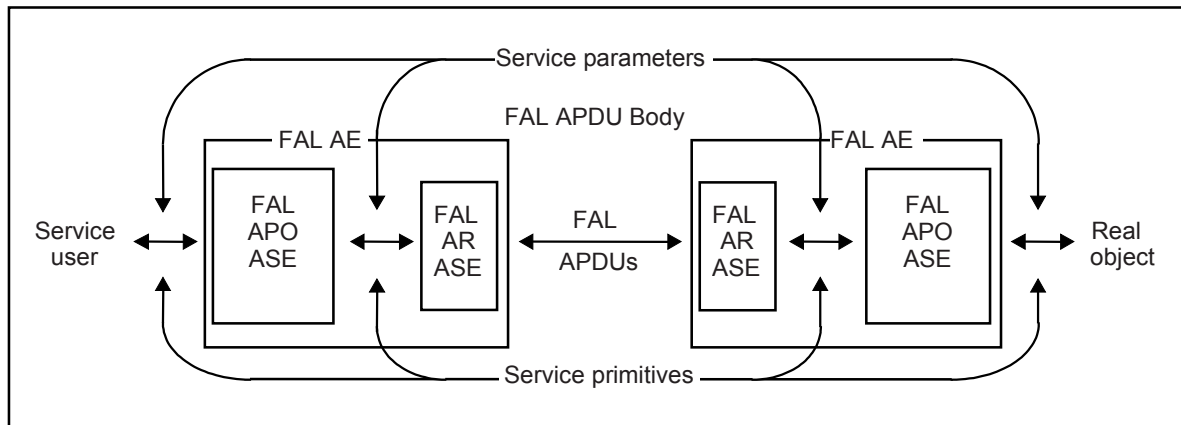

Figure 19 – ASE service conveyance

### 9.3.6.5 FAL presentation context

The presentation context in the OSI environment is used to distinguish the APDUs of one ASE from another, and to identify the transfer syntax rules used to encode each APDU. However, the fieldbus communications architecture does not include the presentation layer. Therefore, an alternate mechanism is provided for the FAL by each of the specific types of communication models.

### 9.3.7 Application relationships

#### 9.3.7.1 Definition of AR

ARs represent communication channels between APs. They define how information is communicated between APs. Each AR is characterized by how it conveys ASE service requests and responses from one AP to another. These characteristics are described below.

#### 9.3.7.2 AR-endpoints

ARs are defined as a set of cooperating APs. The AR ASE in each AP manages an endpoint of the AR, and maintains its local context. The local context of an AR endpoint is used by the AR ASE to control the conveyance of APDUs on the AR.

#### 9.3.7.3 AR-endpoint classes

ARs are composed of a set of endpoints of compatible classes. AR endpoint classes are used to represent AR endpoints that convey APDUs in the same way. Through the standardization of endpoint classes, ARs for different models of interaction can be defined.

#### 9.3.7.4 AR cardinality

ARs characterize communications between APs. One of the characteristics of an AR is the number of AR endpoints in the AR. ARs that convey services between two APs have a cardinality of 1-to-1. Those that convey services from one AP to a number of APs have a cardinality of 1-to-many. Those that convey services from/to multiple APs have a cardinality of many-to-many.

#### 9.3.7.5 Accessing objects through ARs

ARs provide access to APs and the objects within them through the services of one or more ASEs. Therefore, one characteristic is the set of ASE services that may be conveyed to and from these objects by the AR. The list of services that can be conveyed by the AR are selected from those defined for the AE.

#### **9.3.7.6 AR conveyance paths**

ARs are modeled as one or two conveyance paths between AR endpoints. Each conveyance path conveys APDUs in one direction between one or more AR endpoints. Each receiving AR endpoint for a conveyance path receives all APDUs transmitting on the AR by the sending AR endpoint.

#### **9.3.7.7 AREP roles**

Because APs interact with each other through endpoints, a basic determinant of their compatibility is the role that they play in the AR. The role defines how an AREP interacts with other AREPs in the AR.

For example, an AREP may operate as a client, a server, a publisher, or a subscriber. When an AREP interacts with another AREP on a single AR as both a client and a server, it is defined to have the role of “peer”.

Certain roles may be capable of initiating service requests, while others may be capable only of responding to service requests. This part of the definition of a role identifies the requirement for an AR to be capable of conveying requests in either direction, or only in one direction.

#### **9.3.7.8 AREP buffers and queues**

AREPs may be modeled as a queue or as a buffer. APDUs transferred over a queued AREP are delivered in the order received for conveyance. The transfer of APDUs over a buffered AREP is different. In this case, an APDU to be conveyed by the AR ASE is placed in a buffer for transfer. When the data-link layer gains access to the network, it transmits the contents of the buffer.

When the AR ASE receives another conveyance request, it replaces the previous contents of the buffer whether or not they were transmitted. Once an APDU is written into a buffer for transfer, it is preserved in the buffer until the next APDU to be transmitted replaces it. While in the buffer, an APDU may be read more than once without deleting it from the buffer or changing its contents.

At the receiving end, the operation is similar. The receiving endpoint places a received APDU into a buffer for access by the AR ASE. When a subsequent APDU is received, it overwrites the previous APDU in the buffer whether or not it was read. Reading the APDU from the buffer is not destructive — it does not destroy or change the contents of the buffer, allowing the contents to be read from the buffer one or more times.

#### **9.3.7.9 User-triggered and scheduled conveyance**

Another characteristic of an AREP is when they convey service requests and responses. AREPs that convey them upon submission by the user are called user-triggered. Their conveyance is asynchronous with respect to network operation.

AREPs that convey requests and responses at predefined intervals, regardless of when they are received for transfer are termed scheduled. Scheduled AREPs may be capable of indicating when transferred data was submitted late for transmission, or when it was submitted on time, but transmitted late.

#### **9.3.7.10 AREP timeliness**

AREPs convey APDUs between applications using the services of the data-link layer. When the timeliness capabilities are defined for an AREP and supported by the data-link layer, the AREP forwards the timeliness indicators provided by the data-link layer. These timeliness indicators make it possible for subscribers of published data to determine if the data they are receiving is up-to-date or “stale”.

To support these types of timeliness, the publishing AREP establishes a publisher data-link connection reflecting the type of timeliness configured for it by management. After connection establishment, the AREP receives user data and submits it to the DLL for transmission, where timeliness procedures are performed. When the data-link layer has the opportunity to transmit the data, it transmits the current timeliness status with the data.

At the subscriber AREP, a data-link connection is opened to receive published data that reflects the type of timeliness configured for it by management. The data-link layer computes the timeliness of received data and then delivers it to the AREP. The data is then delivered to the user AP through the appropriate ASE.

#### 9.3.7.11 Definition and creation of AREPs

AREP definitions specify instances of AREP classes. AREPs may be predefined or they may be defined using a “create” service if their AE supports this capability.

AREPs may be pre-defined and pre-established, or they may be pre-defined and dynamically established.

Figure 20 depicts these two cases. AREPs also may require both dynamic definition and establishment or they may be dynamically defined in such a way that they may be used without any establishment (they are defined in an established state).

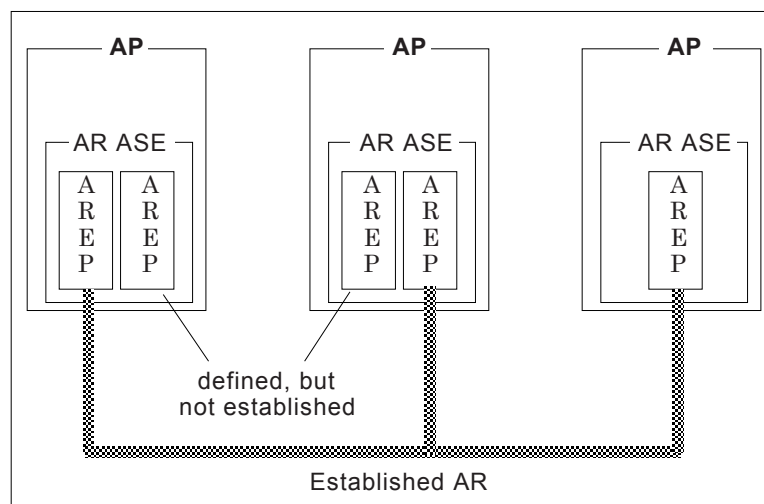

Figure 20 – Defined and established AREPs

#### 9.3.7.12 AR establishment and termination

ARs may be established either before the operational phase of the AP or during its operation. When established during the operation of an AP, the AR is established through the exchange of AR APDUs.

Once an AR has been established, an AR may be terminated gracefully or it may be aborted, depending on the capabilities of the AR.

### 9.4 Fieldbus application layer naming and addressing

#### 9.4.1 General

Subclause 9.4 refines the principles defined in ISO 7498-3 that involve the identification (naming) and location (addressing) of APOs referenced through the fieldbus application layer.

Subclause 9.4 defines how names and numeric identifiers are used to identify APOs accessible through the FAL and indicates how addresses from underlying layers are used to locate APs in the fieldbus environment.

## **9.4.2 Identifying objects accessed through the FAL**

### **9.4.2.1 General**

APOs accessed through the FAL are identified independent of their location. That is, if the location of the AP that contains the APO changes, the APO may still be referenced using the same set of identifiers.

Identifiers for APs and APOs within the FAL are defined as key attributes in the class definitions for APOs. Within these APO definitions, two types of key attributes are commonly used, names and numeric identifiers.

### **9.4.2.2 Names**

Names are string-oriented identifiers. They are defined to permit APs and APOs to be named within the system where they are used. Therefore, although the scope of the name of an APO is specific to the AP in which it resides, the assignment of the name is administered within the system in which it is configured.

Names may be descriptive, although they do not have to be. Descriptive names make it possible to provide meaningful information, such as its use, about the object they name.

Names may also be coded. Coded names make it possible to identify an object using a short, compressed form of a name. They are typically simpler to transfer and process, but not as easy to understand as descriptive names.

### **9.4.2.3 Numeric identifiers**

Numeric identifiers are identifiers whose values are numbers. They are designed for efficient use within the fieldbus system, and may be assigned for efficient access to APOs by their AP.

## **9.4.3 Addressing APs accessed through the FAL**

Fieldbus addresses represent the network locations of APs. Addresses relevant to the FAL are the addresses of the underlying layers that are used to locate the AREPs of an AP.

## **9.5 Architecture summary**

Figure 21 illustrates the major components of the FAL architecture and how they relate to each other.

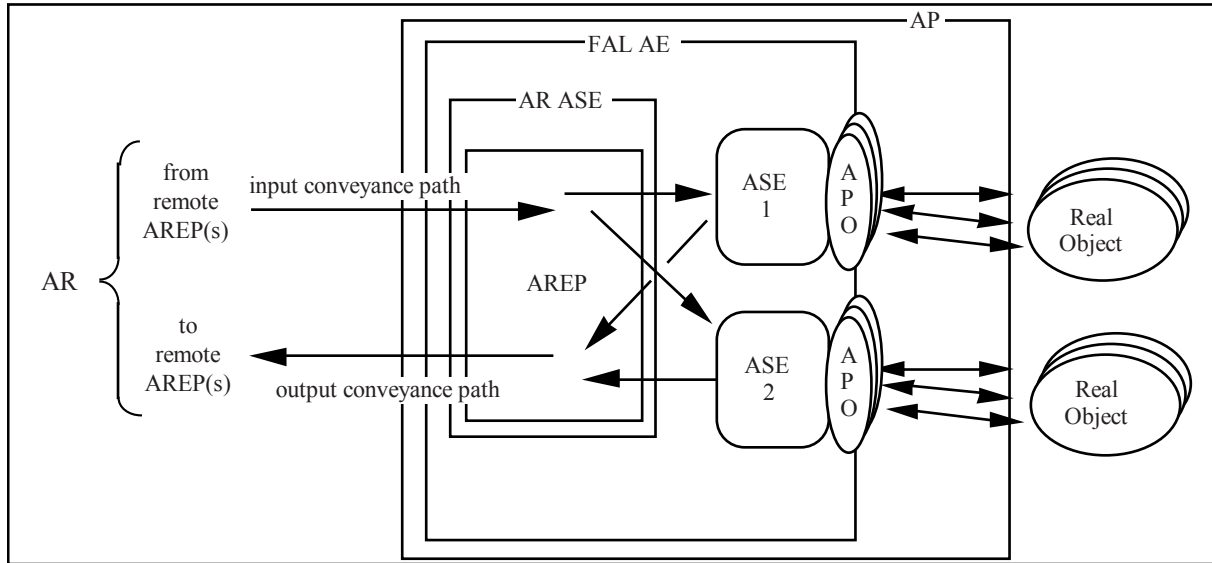

**Figure 21 – FAL architectural components**

Figure 21 depicts an AP that communicates through the FAL AE. The AP represents its internal real objects as APOs for remote access to them. Two ASEs that provide the remote access services to their related APOs are shown. The AR ASE contains a single AREP that conveys service requests and responses for the ASEs to one or more remote AREPs located in remote APs.

## 9.6 Notional FAL service procedures

### 9.6.1 Notional FAL confirmed service procedures

The requesting AL-service user invokes a confirmed-service request primitive of its FAL. The appropriate FAL ASE creates a transaction state machine to control the invocation of the service, assigns an InstanceID and timeout time to that state machine, builds the related confirmed-service-request APDU body including that Instance ID, and conveys it on the specified AR.

Upon receipt of the confirmed-service-request APDU body, the receiving ASE decodes it. If a protocol error did not occur, the receiving ASE creates a transaction state machine to manage the expected response, assigns an independent (second) InstanceID to that state machine, then delivers a confirmed-service indication primitive to its AL-service user, with the (second) InstanceID as an extra implementation parameter.

If the responding AL-service user is able to successfully process the request, the user returns a confirmed-service response (+) primitive, identifying the transaction by the InstanceID presented as part of the stimulating indication primitive.

If the responding user is unable to successfully process the request, the service fails and the user issues a confirmed-service response (–) primitive indicating the reason for failure, again identifying the transaction by the InstanceID presented as part of the stimulating indication primitive.

Whichever response the AL-service users chooses, the receiving ASE has available both the information from the response primitive and that from the associated indication primitive when it forms the APDU to be returned to the initiating ASE.

The responding ASE builds a confirmed-service-response APDU body for a confirmed-service response (+) primitive or a confirmed-service-error APDU body for a confirmed-service

response (–) primitive, either of which contains the (first) InstanceID of the original requesting APDU, and conveys it on the specified AR.

Upon receipt of the response or error APDU body, the initiating ASE uses the (first) InstanceID contained in the response or error APDU to associate the APDU with the appropriate state machine and request. Once that association has been made, the initiating ASE has available both the information from the received APDU and that from the associated request primitive. It delivers a confirmed-service confirmation primitive to the requesting FAL ASE which specifies success or failure, reports the reason for failure if a failure occurred, and cancels the associated transaction state machine.

If the timer associated with the state machine expires before the initiating ASE receives the returned response or error APDU, the AR ASE delivers a confirmed-service confirmation(–) primitive to the requesting FAL ASE and cancels the associated transaction state machine.

### 9.6.2 Notional FAL unconfirmed service procedures

The requesting user invokes an unconfirmed-service request primitive of its FAL AE. The appropriate FAL ASE builds the related unconfirmed-service request APDU body and conveys it on the specified AR.

Upon receipt of the unconfirmed-request APDU body, the receiving ASE(s) participating in the AR delivers the appropriate unconfirmed-service indication primitive to its user. Timeliness parameters are included in the indication primitive if the AR that conveyed the APDU body supports timeliness.

## 9.7 Common FAL attributes

In the specifications of the FAL classes that follow, many classes use the following attributes. Therefore, these attributes are defined here instead of with the other attributes for each of the classes, except for the data-type class.

### ATTRIBUTES:

- |   |     |                |                    |
|---|-----|----------------|--------------------|
| 1 | (o) | Key attribute: | Numeric identifier |
| 2 | (o) | Key attribute: | Name               |
| 3 | (o) | Attribute:     | User description   |
| 4 | (o) | Attribute:     | Object revision    |

#### Numeric identifier

This optional key attribute specifies the numeric id of the object. It is used as a shorthand reference by the FAL protocol to identify the object. There are three possibilities for identification purposes: numeric identifier or name or both. This attribute is required for the data type model.

#### Name

This optional key attribute specifies the name of the object. There are three possibilities for identification purposes: numeric identifier or name or both.

#### User description

This optional attribute specifies user defined descriptive information about the object.

#### Object revision

This optional attribute specifies the revision level of the object. It is a structured attribute composed of major and minor revision numbers. If Object Revision is supported, it contains both a Major Revision and a Minor Revision with a value range 0 to 15 for each. The use of major/minor fields is intended to provide the following features:

#### Major revision

The Major Revision field contains the major revision value for the object. A change to the major revision indicates that interoperability is affected by the change.

#### **Minor revision**

The Minor Revision field contains the minor revision value for the object. A change to the minor revision indicates that interoperability was not affected by the change -- that is users of the object will continue to be capable of interoperating with the object when its minor revision is changed, provided that the major revision remains the same.

### **9.8 Common FAL service parameters**

In the specifications of the FAL services that follow, many services use the following parameters. Therefore, they are defined here instead of with the other parameters for each of the services.

#### **AREP**

This parameter specifies sufficient information to locally identify the AREP to be used to convey the service. This parameter may use a key attribute of the AREP to identify the application relationship. When an AREP supports multiple contexts (established using the initiate service) at the same time, the AREP parameter is extended to identify the context as well as the AREP.

NOTE The AREPs at a request and corresponding indication are local, and therefore not identical. However, they are related by being distinct endpoints of the same AR. The AREPs of results, as conveyed by response and confirm primitives, are those of the corresponding indication and request primitives, respectively. The manner by which an implementation of these abstract services makes that correlation is not specified in the abstract service definition, but it is possible that the manner of correlation is specified in the associated concrete protocol specification.

#### **FAL ASE/FAL class**

This parameter specifies the FAL ASE (e.g. AP, AR, variable, data-type, event, function-invocation, load-region) and the FAL class within the ASE (e.g. AREP, variable-list, notifier, action).

#### **Numeric ID**

This parameter is the numeric identifier of the object.

#### **Error info**

This parameter provides error information for service errors. It is returned in confirmed service response(-) primitives. It is composed of the following elements.

##### **Error class**

This parameter indicates the general class of error. Valid values are specified in the definition of error code parameter, below.

##### **Error code**

This parameter identifies the specific service error.

##### **Additional code**

This optional parameter identifies the error encountered when processing the request specific to the object being accessed. When used, the value submitted in the response primitive is delivered unchanged in the confirmation primitive.

##### **Additional detail**

This optional parameter specifies user data that accompanies the negative response. When used, the value submitted in the response primitive is delivered unchanged in the confirmation primitive.



## 9.9 APDU size

APDU size is communication model dependent.

## 10 Data type ASE

### 10.1 Overview

#### 10.1.1 General

Fieldbus data types specify the machine independent syntax for application data conveyed by FAL services. The fieldbus application layer supports the definition and transfer of both basic and constructed data types. Encoding rules for the data types specified in Clause 10 are provided in the type specific parts of IEC 61158-6.

Basic types are atomic types that cannot be decomposed into more elemental types. Constructed types are types composed of basic types and other constructed types. Their complexity and depth of nesting are not constrained by the parts of the IEC 61158-5 series.

Data types are defined as instances of the data type class, as shown in Figure 22. Only a subset of the data types defined in Clause 10 are shown in Figure 22. Defining new types is accomplished by providing a new numeric id and supplying values for the attributes defined for the data type class.

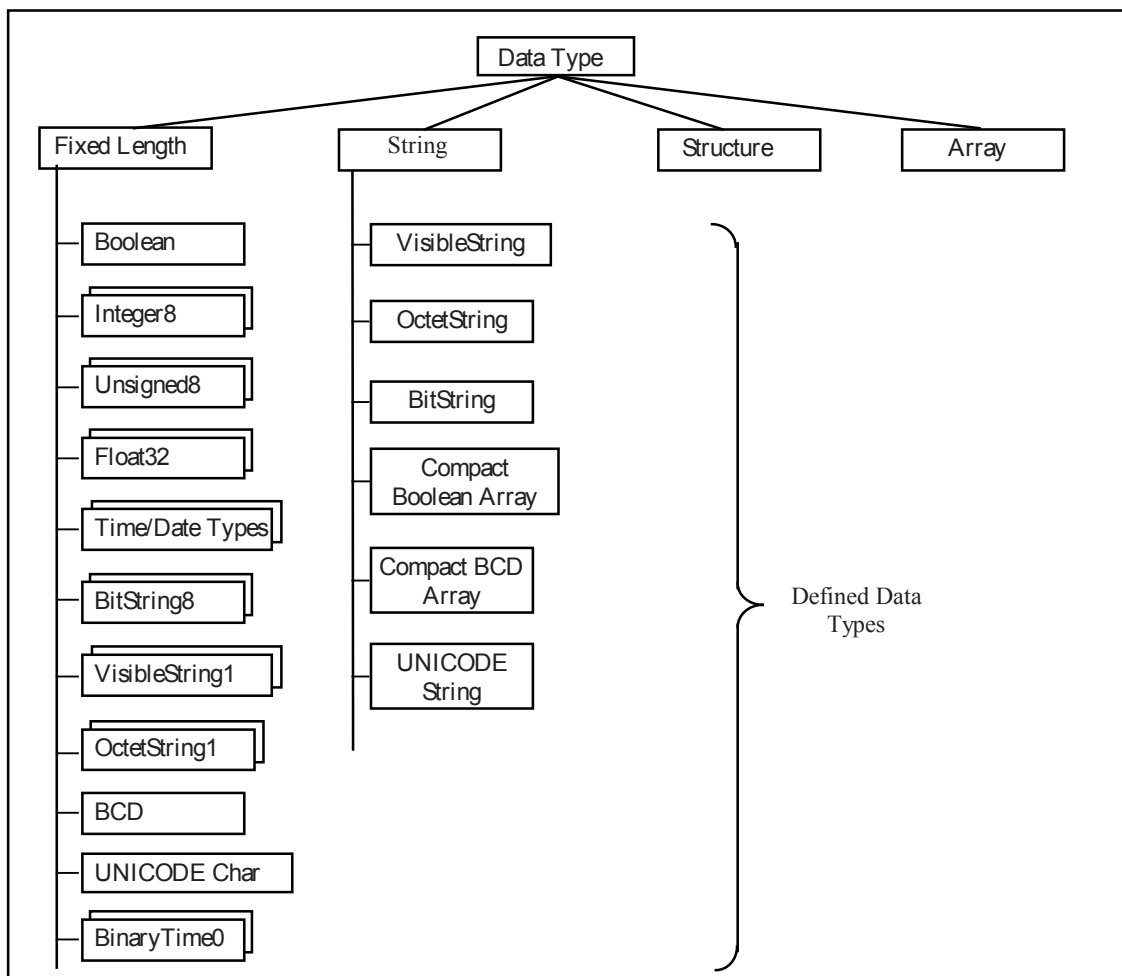

Figure 22 – Data-type class hierarchy example

The data type definitions in Figure 22 are represented as a class/format/instance structure beginning with data type class entitled "data-type". The formats for data types are defined by the data type class and are represented in Figure 22.

The basic data classes are used to define fixed length and bitstring data types. Standard types taken from ISO/IEC 8824 are referred to as *simple* data types. Other standard basic data types are defined specifically for fieldbus applications and are referred to as *specific types*.

The constructed types specified in this part of IEC 61158 are strings, arrays and structures. There are no standard types defined for arrays and structures.

### 10.1.2 Overview of basic types

Most basic types are defined from a set of ISO/IEC 8824 types (simple types). Some ISO/IEC 8824 types have been extended for fieldbus specific use (specific types).

Simple types are ISO/IEC 8824 universal types. They are defined in this part of IEC 61158 to provide them with fieldbus class identifiers.

Specific types are basic types defined specifically for use in the fieldbus environment. They are defined as simple class subtypes.

Basic types have a constant length. Two variations are defined, one for defining data types whose length is an integral number of octets, and one for defining data types whose length is bits.

NOTE Boolean, Integer, OctetString, VisibleString, and UniversalTime are defined in this part of IEC 61158 for the purpose of assigning fieldbus class identifiers to them. This part of IEC 61158 does not change their definitions as specified in ISO/IEC 8824.

### 10.1.3 Overview of fixed-length types

The length of fixed-length types is an integral number of octets.

### 10.1.4 Overview of constructed types

#### 10.1.4.1 Strings

A string is composed of an ordered set, variable in number, of homogeneously typed fixed-length elements.

#### 10.1.4.2 Arrays

An array shall be composed of an ordered set of homogeneously typed elements. There are no restrictions on the data type of array elements placed, but each element shall be of the same type. Once defined, the number of elements in an array may not be changed.

#### 10.1.4.3 Structures

A structure shall be made of an ordered set of heterogeneously-typed elements called fields. Like arrays, this part of 61158 does not restrict the data type of fields. However, the fields within a structure do not have to be of the same type.

#### 10.1.4.4 Nesting level

This part of 61158 permits arrays and structures to contain arrays and structures. It places no restriction on the number of nesting levels allowed.

When an array or structure contains constructed elements, access to a single element in its entirety may be provided. Access to sub elements of the constructed element may also be provided.

### 10.1.5 Specification of user-defined data types

Users may find it necessary to define custom data types for their own applications. User defined types are supported as instances of data type classes.

If user-defined types are supported by a communication type then they shall be specified in the same manner as basic data types are specified. They shall be defined by providing values for the attributes specified for their class.

### 10.1.6 Transfer of user data

User data is transferred between applications by the FAL protocol. All encoding and decoding are performed by the FAL user.

The rules for encoding user data in FAL protocol data units are data type dependent. These rules are defined in parts of the IEC 61158-6 series. User-defined data types for which there are no encoding rules shall be transferred as a variable-length sequence of octets. The format of the data within the octet string shall be defined by the user.

## 10.2 Formal definition of data type objects

### 10.2.1 Data type class

#### 10.2.1.1 Template

The data type class specifies the root of the data type class tree. Its parent class "top" indicates the top of the FAL class tree.

<b>FAL ASE:</b>		<b>DATA TYPE ASE</b>
<b>CLASS:</b>	<b>DATA TYPE</b>	
<b>CLASS ID:</b>		5 (FIXED LENGTH & STRING), 6 (STRUCTURE), 12 (ARRAY)
<b>PARENT CLASS:</b>		TOP
<b>ATTRIBUTES:</b>		
1	(o) Key attribute:	Data type numeric identifier
2	(o) Key attribute:	Data type name
3	(m) Attribute:	Format (FIXED LENGTH, STRING, STRUCTURE, ARRAY)
4	(c) Constraint:	Format = FIXED LENGTH   STRING
4.1	(m) Attribute:	Octet length
5	(c) Constraint:	Format = STRUCTURE
5.1	(m) Attribute:	Number of fields
5.2	(m) Attribute:	List of fields
5.2.1	(o) Attribute:	Field name
5.2.2	(m) Attribute:	Field data type
6	(c) Constraint:	Format = ARRAY
6.1	(m) Attribute:	Number of array elements
6.2	(m) Attribute :	Array element data type

#### 10.2.1.2 Attributes

##### Data type numeric identifier

This optional attribute identifies the numeric identifier of the related data type.

**Data type name**

This optional attribute identifies the name of the related data type.

**Format**

This mandatory attribute identifies the data type as a fixed-length, string, array, or data structure.

**Octet length**

This conditional attribute defines the representation of the dimensions of the associated type object. It is present when the value of the format attribute is "FIXED LENGTH" or "STRING". For FIXED LENGTH data types, it represents the length in octets. For STRING data types, it represents the length in octets for a single element of a string.

**Number of fields**

This conditional attribute defines the number of fields in a structure. It shall be present when the value of the format attribute is "STRUCTURE".

**List of fields**

This conditional attribute is an ordered list of fields contained in the structure. Each field is specified by its number and its type. Fields shall be numbered sequentially from 0 (zero) in the order in which they occur. Partial access to fields within a structure is supported by identifying the field by number. This attribute shall be present when the value of the format attribute is "STRUCTURE".

**Field name**

This conditional, optional attribute specifies the name of the field. It may be present when the value of the format attribute is "STRUCTURE".

**Field data type**

This conditional attribute specifies the data type of the field. It shall be present when the value of the format attribute is "STRUCTURE". This attribute may itself specify a constructed data type either by referencing a constructed data type definition by its numeric id, or by embedding a constructed data type definition here. When embedding a description, the embedded-data-type description shown below shall be used.

**Number of array elements**

This conditional attribute defines the number of elements for the array type. Array elements shall be indexed starting at "0" through "n-1" where the size of the array is "n" elements. This attribute shall be present when the value of the format attribute is "ARRAY".

**Array element data type**

This conditional attribute specifies the data type for the elements of an array. All elements of the array shall have the same data type. It shall be present when the value of the format attribute is "ARRAY". This attribute may itself specify a constructed data type either by referencing a constructed data type definition by its numeric id, or by embedding a constructed data type definition here. When embedding a description, the embedded-data-type description shown below shall be used.

## Embedded-data-type description

This attribute is used to recursively define embedded data types within a structure or array. The template below defines its contents. The attributes shown in the template are defined above in the data type class, except for the embedded-data-type attribute, which is a recursive reference to this attribute. It is used to define nested elements.

### ATTRIBUTES:

1	(m)	Attribute:	Format (FIXED LENGTH, STRING, STRUCTURE, ARRAY)
2	(c)	Constraint:	Format = FIXED LENGTH   STRING
2.1	(m)	Attribute:	Data type numeric ID value
2.2	(m)	Attribute:	Octet length
3	(c)	Constraint:	Format = STRUCTURE
3.1	(m)	Attribute:	Number of fields
3.2	(m)	Attribute:	List of fields
3.2.1	(m)	Attribute:	Embedded data type description
4	(c)	Constraint:	Format = ARRAY
4.1	(m)	Attribute:	Number of array elements
4.2	(m)	Attribute:	Embedded data type description

## 11 Fieldbus system requirements

### 11.1 General

The different industrial automation applications, such as process automation, factory automation and water/waste water treatments have specific requirements. The fieldbus systems defined in IEC 61158 are designed to fulfill the requirements of networks for industrial automation applications.

Clause 11 outlines the fundamental requirements of an industrial control network.

### 11.2 Industrial control network

An industrial control network provides deterministic, reliable and dependable performance for industrial applications. Network and system response times shall always be fast enough to support the application time-constants.

EXAMPLE Motor and motion controls typically need microsecond response times, flow and pressure controls need millisecond response times, and liquid level applications typically need second response times.

NOTE 1 Industrial control networks are also known as industrial automation networks.

NOTE 2 Fieldbuses are designed to fulfill the requirements of industrial control networks.

An industrial control network is a group of devices that share the following features:

- participate in a common user application to provide control or management supervision of a process or machine;
- allocate network resources by a single communication access schedule or a set of interrelated access controls that meet with the intended control application performance.

Industrial control networks support control applications which operate “actuator outputs” to interact with the real world. Incorrect outputs can cause harm to people, the environment and equipment. For these reasons, designers of industrial control networks pay great attention to security and protection from external interference to ensure the installed network maintains its target performance over the entire life cycle.

When industrial control networks communicate with external entities, or other networks, the interconnection can be managed by the network user.

Control applications are typically subject to rigorous safety and security analysis to minimize the consequences of faulty operation and to ensure robustness and integrity.

NOTE 3 See IEC 61784-3 for the relationship of the fieldbus standards in IEC 61158 with other safety standards.

NOTE 4 Applications using other networks such as general sensor networks, ubiquitous networks, and IT networks can also have real privacy and timeliness concerns, however from an industrial viewpoint, such networks are considered to be less critical than industrial control networks.

### **11.3 Communication between industrial control networks and other networks**

Industrial control networks may operate as closed systems or they may include mechanisms for exchange of data with other networks.

An example mechanism is an application gateway that provides proxy functions to filter and manage external requests so that the designed control performance is retained.

Appropriate security measures should be included for all external connections. Additional information can be found in IEC 62443.

### **11.4 Quality of service features of an industrial control network**

#### **11.4.1 General**

To support the requirements of control and monitoring applications, industrial control networks shall have the following characteristics:

- communication access to support timely transfer of data within the time window required by the application;
- prioritized system data transfer to achieve desired performance.

See IEC 61784-1, IEC 61784-2 and IEC 62439 for additional information on performance requirements and high availability networks.

#### **11.4.2 Control data transfer mechanisms**

##### **11.4.2.1 Overview**

The required data transfer performance could be achieved by one or more of the following methods:

- a continuous cyclic operating schedule based on a client/server model (see 9.3.3.3.2),
- a time based operating schedule based on a client/server model (see 9.3.3.3.2) or based on a publisher/subscriber model (see 9.3.3.3.3),
- an event-driven mechanism based on a publisher/subscriber model (see 9.3.3.3.3),
- or other suitable methods.

The configuration process shall ensure that the repetition interval for important control actions is shorter than the sampling interval required by the application.

NOTE 1 The configuration method is beyond the scope of IEC 61158.

NOTE 2 Examples for some configuration methods are in IEC 61804, IEC 62453 and ISO 15745.

#### **11.4.2.2 Continuous cyclic operation**

This method of data transfer uses continuous cyclic repetition of a predefined sequence of exchanges.

If background or unscheduled data transfers are supported, then network management and the schedule construction process shall ensure the worst cycle repetition rate does not prevent acceptable control performance.

#### **11.4.2.3 Time based scheduling**

This method of data transfer uses time triggered repetition of a predefined schedule of 'foreground' data transfer actions.

In these applications, the schedule construction process shall ensure that each part of the schedule ends before the start time for the next part of the schedule. Spare time between the end of one schedule and start of the next may be made available for background or unscheduled data transfer services.

The configuration process shall ensure that scheduled transfers are able to complete within their allocated time slot and initiators of background transfers are not permitted to start any transaction that could overrun the available spare time and delay the start of the next scheduled transfer.

#### **11.4.2.4 Event driven operation**

This method of data transfer uses event flow that determines the scheduling.

#### **11.4.2.5 Non-time-critical communication**

In most industrial control networks, some spare data transfer capacity is reserved for future network expansion and support of background traffic for non-time-critical data transfer. This may include; network configuration, diagnostic and maintenance activities.

### **11.5 Special requirements for wireless networks**

Within one premise different wireless network technologies may be used. Appropriate measures shall be taken for coexistence management for the installed technologies and prevention of external or unwanted interference (see IEC 62657-2).

## Annex A (informative)

### Trade name declarations

Some profile names used in Clause 7 are trade names. Table A.1 shows the tradenames.

**Table A.1 – Trade names of CPFs and CPs**

Family CPF numbers	Technology name
1	FOUNDATION™ fieldbus <sup>2</sup>
2	CIP™ <sup>3</sup>
CP 2/1	ControlNet™ <sup>3</sup>
CP 2/2	EtherNet/IP™ <sup>3</sup>
CP 2/3	DeviceNet™ <sup>3</sup>
3	PROFIBUS & PROFINET <sup>4</sup>
4	P-NET® <sup>5</sup>
5	WorldFIP® <sup>6</sup>
6	INTERBUS® <sup>7</sup>
8	CC-Link and CC-LINK IE <sup>8</sup>
9	HART®, WirelessHART® <sup>9</sup>

<sup>2</sup> FOUNDATION™ Fieldbus is the trade name of the non-profit consortium Fieldbus Foundation. This information is given for the convenience of users of this part of IEC 61158 and does not constitute an endorsement by IEC of the trademark holder or any of its products. Compliance does not require use of the trade name. Use of the trade name requires permission of the trade name holder

<sup>3</sup> CIP™, ControlNet™, EtherNet/IP™ and DeviceNet™ are trade names of ODVA, Inc. This information is given for the convenience of users of this part of IEC 61158 and does not constitute an endorsement by IEC of the trademark holder or any of its products. Compliance does not require use of the trade names. Use of the trade names requires permission of the trade name holder.

<sup>4</sup> PROFIBUS and PROFINET are trade names of the non-profit organization PROFIBUS Nutzerorganisation e.V. (PNO). This information is given for the convenience of users of this part of IEC 61158 and does not constitute an endorsement by IEC of the trade names holder or any of its products. Compliance does not require use of the registered trade name. Use of the trade names requires permission of the trade name holder.

<sup>5</sup> P-NET is the trade name of International P-NET User Organisation ApS (IPUO). This information is given for the convenience of users of this part of IEC 61158 and does not constitute an endorsement by IEC of the trademark holder or any of its products. Compliance does not require use of the trade name. Use of the trade name requires permission of the trade name holder.

<sup>6</sup> WorldFIP is the trade name of the WorldFIP organization. This information is given for the convenience of users of this part of IEC 61158 and does not constitute an endorsement by IEC of the trademark holder or any of its products. Compliance does not require use of the trade name. Use of the trade name requires permission of the trade name holder.

<sup>7</sup> INTERBUS is the trade name of Phoenix Contact GmbH & Co. KG., control of trade name use is given to the non profit organization INTERBUS Club. This information is given for the convenience of users of this part of IEC 61158 and does not constitute an endorsement by IEC of the trademark holder or any of its products. Compliance does not require use of the trade name. Use of the trade name requires permission of the trade name holder.

<sup>8</sup> CC-Link, CC-Link/LT and CC-Link IE are trade names of Mitsubishi Electric Co., control of trade name use is given to CC-Link Partner Association. This information is given for the convenience of users of this part of IEC 61158 and does not constitute an endorsement by IEC of the trademark holder or any of its products. Compliance does not require use of the trade name. Use of the trade name requires permission of the trade name holder.

<sup>9</sup> HART and WirelessHART are registered trade names of the HART Communications Foundation. This information is given for the convenience of users of this part of IEC 61158 and does not constitute an endorsement by IEC of the trademark holder or any of its products. Compliance does not require use of the trade name. Use of the trade name requires permission of the trade name holder.



Family CPF numbers	Technology name
10	Vnet/IP <sup>10</sup>
11	TCnet <sup>11</sup>
12	EtherCAT <sup>®12</sup>
13	Ethernet POWERLINK <sup>13</sup>
14	EPA <sup>14</sup>
15	MODBUS <sup>®-RTPS15</sup>
16	SERCOS <sup>16</sup>
17	RAPIenet <sup>17</sup>
18	SafetyNET p <sup>18</sup>
19	MECHATROLINK <sup>19</sup>

- 
- <sup>10</sup> Vnet/IP is a trade name of Yokogawa Electric Corporation. This information is given for the convenience of users of this part of IEC 61158 and does not constitute an endorsement by IEC of the trademark holder or any of its products. Compliance does not require use of the trade name. Use of the trade name requires permission of the trade name holder.
- <sup>11</sup> In Japan, TCnet is a trade name of TOSHIBA Corporation. This information is given for the convenience of users of this part of IEC 61158 and does not constitute an endorsement by IEC of the trademark holder or any of its products. Compliance does not require use of the trade name. Use of the trade name requires permission of the trade name holder.
- <sup>12</sup> EtherCAT<sup>™</sup> and Safety-over-EtherCAT<sup>™</sup> are registered trade names of Beckhoff, Verl. This information is given for the convenience of users of this part of IEC 61158 and does not constitute an endorsement by IEC of the trademark holder or any of its products. Compliance does not require use of the trade names. Use of the trade names requires permission of the trade name holder.
- <sup>13</sup> Ethernet POWERLINK is a trade name of Bernecker&Rainer Industrieelektronik Ges.m.b.H., control of trade name use is given to the non profit organization EPSG. This information is given for the convenience of users of this part of IEC 61158 and does not constitute an endorsement by IEC of the trademark holder or any of its products. Compliance does not require use of the trade name. Use of the trade name requires permission of the trade name holder.
- <sup>14</sup> EPA<sup>™</sup> is a trade name of SUPCON Group Co. Ltd. This information is given for the convenience of users of this part of IEC 61158 and does not constitute an endorsement by IEC of the trademark holder or any of its products. Compliance does not require use of the trade name. Use of the trade name requires permission of the trade name holder.
- <sup>15</sup> Modbus is a trademark of Schneider Automation Inc., registered in the United States of America and other countries. This information is given for the convenience of users of this part of IEC 61158 and does not constitute an endorsement by IEC of the trademark holder or any of its products. Compliance does not require use of the trademark. Use of the trademark requires permission of the trademark holder.
- <sup>16</sup> SERCOS is a trade name of sercos international e.V. This information is given for the convenience of users of this part of IEC 61158 and does not constitute an endorsement by IEC of the trademark holder or any of its products. Compliance does not require use of the trade name. Use of the trade name requires permission of the trade name holder.
- <sup>17</sup> RAPIenet is a trade name of LSIS. This information is given for the convenience of users of this part of IEC 61158 and does not constitute an endorsement by IEC of the trademark holder or any of its products. Compliance to this profile does not require use of the trade name RAPIenet. Use of the trade name RAPIenet requires permission of the trade name holder.
- <sup>18</sup> SafetyNET p is a trade name of the Pilz GmbH & Co. KG. This information is given for the convenience of users of this part of IEC 61158 and does not constitute an endorsement by IEC of the trade name holder or any of its products. Compliance does not require use of the trade name SafetyNET p. Use of the trade name SafetyNET p requires permission of the trade name holder.
- <sup>19</sup> MECHATROLINK is a trade name of YASKAWA ELECTRIC CORPORATION. This information is given for the convenience of users of this part of IEC 61158 and does not constitute an endorsement by IEC of the trade name holder or any of its products. Compliance does not require use of the trade name. Use of the trade name requires permission of the trade name holder.

## **Annex B** (informative)

### **Media selection for fieldbus systems**

#### **B.1 General**

The essential criteria for an acceptable industrial control network media is the provision of required data transfer capacity with suitable immunity to electromagnetic and environmental interference, and acceptable levels of lifetime cost for installation and maintenance.

The different fieldbus types specified in IEC 61158 provide access to several types of media with acceptable channel data transfer performance so the user choice can be made on a cost / benefit basis.

#### **B.2 Cabled media**

Cabled media may be wire, or fibre, most installations require dedicated media.

See 8.1 for a summary of the supported media and IEC 61158-2 for details of the various fieldbus types. IEC 61784-1 and IEC 61784-2 provide the recommended media for each fieldbus communication profile. IEC 61918 and the type specific parts of IEC 61784-5 specify the distinct installation requirements.

#### **B.3 Wireless media**

The requirements of and guidance for selecting among different solutions for wireless communication networks in industrial applications are specified in IEC/TS 62657-1.

#### **B.4 Media needing special consideration**

To fulfill specific application requirements it might be necessary in industrial control networks to use media not specified in IEC 61158, examples are

- leased line or dedicated channel in a third party or public telephone network,
- licensed radio band,
- public telephone dial up connection,
- Ethernet or internet technology over office/factory networks, provided that the routers are configured to provide reserved bandwidth for industrial control network traffic,
- wireless communication with unknown characteristics over public radio bands, or
- other unknown networks.

NOTE The use of these media is beyond the scope of this part of IEC 61158.

## **B.5 Performance characteristics of open and public networks**

### **B.5.1 Public network types**

Many networks use publicly available or open communication facilities such as WiFi, unlicensed wireless bands, public internet channels, public telephone networks.

The structure of these networks is usually described as open, flexible, ubiquitous, reconfigurable, self-organizing, adaptive.

In general, membership in a public network is available to any device or person with the appropriate technical capability and meeting the registration or subscription requirements.

### **B.5.2 Performance characteristics of public networks**

#### **B.5.2.1 Lack of predictability and reliability**

Any new device meeting the participation requirements of a public network can exert its right to communicate, this will degrade existing application performance by one or more of the following mechanisms.

- Destructive collisions. Open networks have a continually changing population of devices able to use the media. At any time, one or more devices may attempt to communicate causing destructive collisions, reduced bandwidth availability and lack of determinism.
- Randomly changing message transfer performance. Open internet and telephone based networks are able to avoid destructive collisions by various techniques. However, access delays still occur and throughput performance will always randomly change with the number of active users of the network.
- Denial-of-services attacks might be encountered.

For these reasons, message transfer performance in public networks will always be unpredictable.

#### **B.5.2.2 Unsuitability for control applications**

Most control applications require deterministic, reliable and dependable communications performance with known worst case responses.

The unpredictable nature of open and public networks means they are not suitable for control or any application that needs reliable, deterministic and dependable communication performance.

Open networks also have significant concerns related to privacy and security.

Owners of environments that include open networks need to ensure the networks are managed to minimise interference and provide the designed application performance throughout their lifetime.

## Bibliography

NOTE 1 All parts of the IEC 61158 series, as well as IEC 61784-1 and IEC 61784-2 are maintained simultaneously. Cross-references to these documents within the text therefore refer to the editions as dated in this bibliography.

NOTE 2 Maintenance of the IEC 61158 series does not always include all parts of the IEC 61158 series. For the convenience of the user all parts of the IEC 61158 series and of the IEC 61784 series, as well as references to IEC 61918 are dated in the Bibliography of this part of IEC 61158 to indicate a consistent set of these standards.

IEC 60793-2-30:2012, *Optical fibres – Part 2-30: Product specifications – Sectional specification for category A3 multimode fibres*

IEC 60793-2-40:2009, *Optical fibres – Part 2-40: Product specifications – Sectional specification for category A4 multimode fibres*

IEC 61000-6-2, *Electromagnetic compatibility (EMC) – Part 6-2: Generic standards – Immunity for industrial environments*

IEC 61131-2, *Programmable controllers – Part 2: Equipment requirements and tests*

IEC 61158 (all parts), *Industrial communication networks – Fieldbus specifications*

IEC 61158-2:2014, *Industrial communication networks – Fieldbus specifications – Part 2: Physical layer specification and service definition*

IEC 61158-3-1:2014, *Industrial communication networks – Fieldbus specifications – Part 3-1: Data-link layer service definition – Type 1 elements*

IEC 61158-3-2:2014, *Industrial communication networks – Fieldbus specifications – Part 3-2: Data-link layer service definition – Type 2 elements*

IEC 61158-3-3:2014, *Industrial communication networks – Fieldbus specifications – Part 3-3: Data-link layer service definition – Type 3 elements*

IEC 61158-3-4:2014, *Industrial communication networks – Fieldbus specifications – Part 3-4: Data-link layer service definition – Type 4 elements*

IEC 61158-3-7:2007, *Industrial communication networks – Fieldbus specifications – Part 3-7: Data-link layer service definition – Type 7 elements*

IEC 61158-3-8:2007, *Industrial communication networks – Fieldbus specifications – Part 3-8: Data-link layer service definition – Type 8 elements*

IEC 61158-3-11:2007, *Industrial communication networks – Fieldbus specifications – Part 3-11: Data-link layer service definition – Type 11 elements*

IEC 61158-3-12:2014, *Industrial communication networks – Fieldbus specifications – Part 3-12: Data-link layer service definition – Type 12 elements*

IEC 61158-3-13:2014, *Industrial communication networks – Fieldbus specifications – Part 3-13: Data-link layer service definition – Type 13 elements*

IEC 61158-3-14:2014, *Industrial communication networks – Fieldbus specifications – Part 3-14: Data-link layer service definition – Type 14 elements*

IEC 61158-3-16:2007, *Industrial communication networks – Fieldbus specifications – Part 3-16: Data-link layer service definition – Type 16 elements*

IEC 61158-3-17:2007, *Industrial communication networks – Fieldbus specifications – Part 3-17: Data-link layer service definition – Type 17 elements*

IEC 61158-3-18:2007, *Industrial communication networks – Fieldbus specifications – Part 3-18: Data-link layer service definition – Type 18 elements*

IEC 61158-3-19:2014, *Industrial communication networks – Fieldbus specifications – Part 3-19: Data-link layer service definition – Type 19 elements*

IEC 61158-3-20:2014, *Industrial communication networks – Fieldbus specifications – Part 3-20: Data-link layer service definition – Type 20 elements*

IEC 61158-3-21:2010, *Industrial communication networks – Fieldbus specifications – Part 3-21: Data-link layer service definition – Type 21 elements*

IEC 61158-3-22:2014, *Industrial communication networks – Fieldbus specifications – Part 3-22: Data-link layer service definition – Type 22 elements*

IEC 61158-3-24:2014, *Industrial communication networks – Fieldbus specifications – Part 3-24: Data-link layer service definition – Type 24 elements*

IEC 61158-4-1:2014, *Industrial communication networks – Fieldbus specifications – Part 4-1: Data-link layer protocol specification – Type 1 elements*

IEC 61158-4-2:2014, *Industrial communication networks – Fieldbus specifications – Part 4-2: Data-link layer protocol specification – Type 2 elements*

IEC 61158-4-3:2014, *Industrial communication networks – Fieldbus specifications – Part 4-3: Data-link layer protocol specification – Type 3 elements*

IEC 61158-4-4:2014, *Industrial communication networks – Fieldbus specifications – Part 4-4: Data-link layer protocol specification – Type 4 elements*

IEC 61158-4-7:2007, *Industrial communication networks – Fieldbus specifications – Part 4-7: Data-link layer protocol specification – Type 7 elements*

IEC 61158-4-8:2007, *Industrial communication networks – Fieldbus specifications – Part 4-8: Data-link layer protocol specification – Type 8 elements*

IEC 61158-4-11:2014, *Industrial communication networks – Fieldbus specifications – Part 4-11: Data-link layer protocol specification – Type 11 elements*

IEC 61158-4-12:2014, *Industrial communication networks – Fieldbus specifications – Part 4-12: Data-link layer protocol specification – Type 12 elements*

IEC 61158-4-13:2014, *Industrial communication networks – Fieldbus specifications – Part 4-13: Data-link layer protocol specification – Type 13 elements*

IEC 61158-4-14:2014, *Industrial communication networks – Fieldbus specifications – Part 4-14: Data-link layer protocol specification – Type 14 elements*

IEC 61158-4-16:2007, *Industrial communication networks – Fieldbus specifications – Part 4-16: Data-link layer protocol specification – Type 16 elements*

IEC 61158-4-17:2007, *Industrial communication networks – Fieldbus specifications – Part 4-17: Data-link layer protocol specification – Type 17 elements*

IEC 61158-4-18:2010, *Industrial communication networks – Fieldbus specifications – Part 4-18: Data-link layer protocol specification – Type 18 elements*

IEC 61158-4-19:2014, *Industrial communication networks – Fieldbus specifications – Part 4-19: Data-link layer protocol specification – Type 19 elements*

IEC 61158-4-20:2014, *Industrial communication networks – Fieldbus specifications – Part 4-20: Data-link layer protocol specification – Type 20 elements*

IEC 61158-4-21:2010, *Industrial communication networks – Fieldbus specifications – Part 4-21: Data-link layer protocol specification – Type 21 elements*

IEC 61158-4-22:2014, *Industrial communication networks – Fieldbus specifications – Part 4-22: Data-link layer protocol specification – Type 22 elements*

IEC 61158-4-24:2014, *Industrial communication networks – Fieldbus specifications – Part 4-24: Data-link layer protocol specification – Type 24 elements*

IEC 61158-5-2:2014, *Industrial communication networks – Fieldbus specifications – Part 5-2: Application layer service definition – Type 2 elements*

IEC 61158-5-3:2014, *Industrial communication networks – Fieldbus specifications – Part 5-3: Application layer service definition – Type 3 elements*

IEC 61158-5-4:2014, *Industrial communication networks – Fieldbus specifications – Part 5-4: Application layer service definition – Type 4 elements*

IEC 61158-5-5:2014, *Industrial communication networks – Fieldbus specifications – Part 5-5: Application layer service definition – Type 5 elements*

IEC 61158-5-7:2007, *Industrial communication networks – Fieldbus specifications – Part 5-7: Application layer service definition – Type 7 elements*

IEC 61158-5-8:2007, *Industrial communication networks – Fieldbus specifications – Part 5-8: Application layer service definition – Type 8 elements*

IEC 61158-5-9:2014, *Industrial communication networks – Fieldbus specifications – Part 5-9: Application layer service definition – Type 9 elements*

IEC 61158-5-10:2014, *Industrial communication networks – Fieldbus specifications – Part 5-10: Application layer service definition – Type 10 elements*

IEC 61158-5-11:2007, *Industrial communication networks – Fieldbus specifications – Part 5-11: Application layer service definition – Type 11 elements*

IEC 61158-5-12:2014, *Industrial communication networks – Fieldbus specifications – Part 5-12: Application layer service definition – Type 12 elements*

IEC 61158-5-13:2014, *Industrial communication networks – Fieldbus specifications – Part 5-13: Application layer service definition – Type 13 elements*

IEC 61158-5-14:2014, *Industrial communication networks – Fieldbus specifications – Part 5-14: Application layer service definition – Type 14 elements*

IEC 61158-5-15:2010, *Industrial communication networks – Fieldbus specifications – Part 5-15: Application layer service definition – Type 15 elements*



IEC 61158-5-16:2007, *Industrial communication networks – Fieldbus specifications – Part 5-16: Application layer service definition – Type 16 elements*

IEC 61158-5-17:2007, *Industrial communication networks – Fieldbus specifications – Part 5-17: Application layer service definition – Type 17 elements*

IEC 61158-5-18:2010, *Industrial communication networks – Fieldbus specifications – Part 5-18: Application layer service definition – Type 18 elements*

IEC 61158-5-19:2014, *Industrial communication networks – Fieldbus specifications – Part 5-19: Application layer service definition – Type 19 elements*

IEC 61158-5-20:2014, *Industrial communication networks – Fieldbus specifications – Part 5-20: Application layer service definition – Type 20 elements*

IEC 61158-5-21:2010, *Industrial communication networks – Fieldbus specifications – Part 5-21: Application layer service definition – Type 21 elements*

IEC 61158-5-22:2010, *Industrial communication networks – Fieldbus specifications – Part 5-22: Application layer service definition – Type 22 elements*

IEC 61158-5-23:2014, *Industrial communication networks – Fieldbus specifications – Part 5-23: Application layer service definition – Type 23 elements*

IEC 61158-5-24:2014, *Industrial communication networks – Fieldbus specifications – Part 5-24: Application layer service definition – Type 24 elements*

IEC 61158-6-2:2014, *Industrial communication networks – Fieldbus specifications – Part 6-2: Application layer protocol specification – Type 2 elements*

IEC 61158-6-3:2014, *Industrial communication networks – Fieldbus specifications – Part 6-3: Application layer protocol specification – Type 3 elements*

IEC 61158-6-4:2014, *Industrial communication networks – Fieldbus specifications – Part 6-4: Application layer protocol specification – Type 4 elements*

IEC 61158-6-5:2014, *Industrial communication networks – Fieldbus specifications – Part 6-5: Application layer protocol specification – Type 5 elements*

IEC 61158-6-7:2007, *Industrial communication networks – Fieldbus specifications – Part 6-7: Application layer protocol specification – Type 7 elements*

IEC 61158-6-8:2007, *Industrial communication networks – Fieldbus specifications – Part 6-8: Application layer protocol specification – Type 8 elements*

IEC 61158-6-9:2014, *Industrial communication networks – Fieldbus specifications – Part 6-9: Application layer protocol specification – Type 9 elements*

IEC 61158-6-10:2014, *Industrial communication networks – Fieldbus specifications – Part 6-10: Application layer protocol specification – Type 10 elements*

IEC 61158-6-11:2007, *Industrial communication networks – Fieldbus specifications – Part 6-11: Application layer protocol specification – Type 11 elements*

IEC 61158-6-12:2014, *Industrial communication networks – Fieldbus specifications – Part 6-12: Application layer protocol specification – Type 12 elements*

- IEC 61158-6-13:2014, *Industrial communication networks – Fieldbus specifications – Part 6-13: Application layer protocol specification – Type 13 elements*
- IEC 61158-6-14:2014, *Industrial communication networks – Fieldbus specifications – Part 6-14: Application layer protocol specification – Type 14 elements*
- IEC 61158-6-15:2010, *Industrial communication networks – Fieldbus specifications – Part 6-15: Application layer protocol specification – Type 15 elements*
- IEC 61158-6-16:2007, *Industrial communication networks – Fieldbus specifications – Part 6-16: Application layer protocol specification – Type 16 elements*
- IEC 61158-6-17:2007, *Industrial communication networks – Fieldbus specifications – Part 6-17: Application layer protocol specification – Type 17 elements*
- IEC 61158-6-18:2010, *Industrial communication networks – Fieldbus specifications – Part 6-18: Application layer protocol specification – Type 18 elements*
- IEC 61158-6-19:2014, *Industrial communication networks – Fieldbus specifications – Part 6-19: Application layer protocol specification – Type 19 elements*
- IEC 61158-6-20:2014, *Industrial communication networks – Fieldbus specifications – Part 6-20: Application layer protocol specification – Type 20 elements*
- IEC 61158-6-21:2010, *Industrial communication networks – Fieldbus specifications – Part 6-21: Application layer protocol specification – Type 21 elements*
- IEC 61158-6-22:2014, *Industrial communication networks – Fieldbus specifications – Part 6-22: Application layer protocol specification – Type 22 elements*
- IEC 61158-6-23:2014, *Industrial communication networks – Fieldbus specifications – Part 6-23: Application layer protocol specification – Type 23 elements*
- IEC 61158-6-24:2014, *Industrial communication networks – Fieldbus specifications – Part 6-24: Application layer protocol specification – Type 24 elements*
- IEC 61326 (all parts), *Electrical equipment for measurement, control and laboratory use – EMC requirements*
- IEC 61508 (all parts), *Functional safety of electrical/electronic/programmable electronic safety-related systems*
- IEC 61784-1:2014, *Industrial communication networks – Profiles – Part 1: Fieldbus profiles*
- IEC 61784-2:2014, *Industrial communication networks – Profiles – Part 2: Additional fieldbus profiles for real-time networks based on ISO/IEC 8802-3*
- IEC 61784-3:2010, *Industrial communication networks – Profiles – Part 3: Functional safety fieldbuses – General rules and profile definitions*
- IEC 61784-3-1:2010, *Industrial communication networks – Profiles – Part 3-1: Functional safety fieldbuses – Additional specifications for CPF 1*
- IEC 61784-3-2:2010, *Industrial communication networks – Profiles – Part 3-2: Functional safety fieldbuses – Additional specifications for CPF 2*



IEC 61784-3-3:2010, *Industrial communication networks – Profiles – Part 3-3: Functional safety fieldbuses – Additional specifications for CPF 3*

IEC 61784-3-6:2010, *Industrial communication networks – Profiles – Part 3-6: Functional safety fieldbuses – Additional specifications for CPF 6*

IEC 61784-3-8:2010, *Industrial communication networks – Profiles – Part 3-8: Functional safety fieldbuses – Additional specifications for CPF 8*

IEC 61784-3-12:2010, *Industrial communication networks – Profiles – Part 3-12: Functional safety fieldbuses – Additional specifications for CPF 12*

IEC 61784-3-13:2010, *Industrial communication networks – Profiles – Part 3-13: Functional safety fieldbuses – Additional specifications for CPF 13*

IEC 61784-3-14:2010, *Industrial communication networks – Profiles – Part 3-14: Functional safety fieldbuses – Additional specifications for CPF 14*

IEC 61784-3-18:2011, *Industrial communication networks – Profiles – Part 3-18: Functional safety fieldbuses – Additional specifications for CPF 18*

IEC 61784-5-1:2013, *Industrial communication networks – Profiles – Part 5-1: Installation of fieldbuses – Installation profiles for CPF 1*

IEC 61784-5-2:2013, *Industrial communication networks – Profiles – Part 5-2: Installation of fieldbuses – Installation profiles for CPF 2*

IEC 61784-5-3:2013, *Industrial communication networks – Profiles – Part 5-3: Installation of fieldbuses – Installation profiles for CPF 3*

IEC 61784-5-4:2010, *Industrial communication networks – Profiles – Part 5-4: Installation of fieldbuses – Installation profiles for CPF 4*

IEC 61784-5-6:2013, *Industrial communication networks – Profiles – Part 5-6: Installation of fieldbuses – Installation profiles for CPF 6*

IEC 61784-5-8:2013, *Industrial communication networks – Profiles – Part 5-8: Installation of fieldbuses – Installation profiles for CPF 8*

IEC 61784-5-10:2010, *Industrial communication networks – Profiles – Part 5-10: Installation of fieldbuses – Installation profiles for CPF 10*

IEC 61784-5-11:2013, *Industrial communication networks – Profiles – Part 5-11: Installation of fieldbuses – Installation profiles for CPF 11*

IEC 61784-5-12:2010, *Industrial communication networks – Profiles – Part 5-12: Installation of fieldbuses – Installation profiles for CPF 12*

IEC 61784-5-13:2013, *Industrial communication networks – Profiles – Part 5-13: Installation of fieldbuses – Installation profiles for CPF 13*

IEC 61784-5-14:2013, *Industrial communication networks – Profiles – Part 5-14: Installation of fieldbuses – Installation profiles for CPF 14*

IEC 61784-5-15:2010, *Industrial communication networks – Profiles – Part 5-15: Installation of fieldbuses – Installation profiles for CPF 15*

IEC 61784-5-16:2013, *Industrial communication networks – Profiles – Part 5-16: Installation of fieldbuses – Installation profiles for CPF 16*

IEC 61784-5-17:2013, *Industrial communication networks – Profiles – Part 5-17: Installation of fieldbuses – Installation profiles for CPF 17*

IEC 61784-5-18:2013, *Industrial communication networks – Profiles – Part 5-18: Installation of fieldbuses – Installation profiles for CPF 18*

IEC 61784-5-19:2013, *Industrial communication networks – Profiles – Part 5-19: Installation of fieldbuses – Installation profiles for CPF 19*

IEC 61804 (all parts), *Function blocks (FB) for process control*

IEC 61918:2013, *Industrial communication networks – Installation of communication networks in industrial premises*

IEC/TR 62390, *Common automation device – Profile guideline*

IEC 62439 (all parts), *Industrial communication networks – High availability automation networks*

IEC 62443 (all parts), *Industrial communication networks – Network and system security*

IEC 62453 (all parts), *Field device tool (FDT) interface specification*

IEC 62591, *Industrial communication networks – Wireless communication network and communication profiles – WirelessHART*

IEC 62601, *Industrial communication networks – Fieldbus specifications – WIA-PA communication network and communication profile*

IEC/TS 62657-1<sup>20</sup>, *Industrial communication networks – Wireless communication networks – Part 1: Wireless communication requirements and spectrum considerations*

IEC 62657-2, *Industrial communication networks – Wireless communication networks – Part 2: Coexistence management*

IEC 62734, *Industrial communications networks – Wireless communication network and communication profiles – ISA 100.11A*

IEC/TR 62685:2010, *Industrial communication networks – Profiles – Assessment guideline for safety devices using IEC 61784-3 functional safety communication profiles (FSCPs)*

ISO/IEC 2382-16, *Information technology – Vocabulary – Part 16: Information theory*

ISO/IEC 7498-1, *Information technology – Open Systems Interconnection – Basic Reference Model: The Basic Model*

ISO/IEC 7498-3, *Information technology – Open Systems Interconnection – Basic Reference Model: Naming and addressing*

---

<sup>20</sup> To be published.

ISO/IEC 8802-3, *Information technology – Telecommunications and information exchange between systems – Local and metropolitan area networks – Specific requirements – Part 3: Carrier sense multiple access with collision detection (CSMA/CD) access method and physical layer specifications*

ISO/IEC 8824 (all parts), *Information Technology – Abstract Syntax Notation One (ASN-1)*

ISO/IEC 8886:1996, *Information technology – Open systems interconnection – Data link service definition*

ISO/IEC 9545, *Information technology – Open Systems Interconnection – Application Layer structure*

ISO/IEC TR 10000-1:1998, *Information technology – Framework and taxonomy of International Standardized Profiles – Part 1: General principles and documentation framework*

ISO/IEC 10731, *Information technology – Open Systems Interconnection – Basic Reference Model – Conventions for the definition of OSI services*

ISO 11898-1, *Road vehicles – Controller area network (CAN) – Part 1: Data link layer and physical signaling*

ISO 11898-2, *Road vehicles – Controller area network (CAN) – Part 2: High-speed medium access unit*

ISO 15745 (all parts), *Industrial automation systems and integration – Open systems application integration framework*

ANSI TIA/EIA-644-A, *Electrical Characteristics of Low Voltage Differential Signaling (LVDS) Interface Circuits*

IEEE 802.3, *IEEE Standard for Information technology – Telecommunications and Information exchange between systems – Local and Metropolitan Area Networks – Specific Requirements – Part 3: Carrier Sense Multiple Access with Collision Detection (CSMA/CD) Access Method and Physical Layer*

IEEE Std 802.11, *IEEE Standard for Information technology — Telecommunications and information exchange between systems — Local and metropolitan area networks— Specific requirements — Part 11: Wireless LAN Medium Access Control (MAC) and Physical Layer (PHY) Specifications*

IEEE 802.15.4, *IEEE Standard for Local and metropolitan area networks – Part 15.4: Low-211 Rate Wireless Personal Area Networks (LR-WPANs)*

IETF RFC 791, *Internet Protocol*; available at <<http://www.ietf.org>>

GS-ET-26, *Grundsatz für die Prüfung und Zertifizierung von Bussystemen für die Übertragung sicherheitsrelevanter Nachrichten*, May 2002. HVBG, Gustav-Heinemann-Ufer 130, D-50968 Köln ("*Principles for Test and Certification of Bus Systems for Safety relevant Communication*")

ODVA: THE CIP NETWORKS LIBRARY – Volume 1: *Common Industrial Protocol (CIP™) – Edition 3.13*, November 2012, available at <<http://www.odva.org>>

ODVA: THE CIP NETWORKS LIBRARY – Volume 2: *EtherNet/IP™ Adaptation of CIP – Edition 1.14*, November 2012, available at <<http://www.odva.org>>

ODVA: THE CIP NETWORKS LIBRARY – Volume 3: *DeviceNet™ Adaptation of CIP – Edition 1.12, November 2011*, available at <<http://www.odva.org>>

ODVA: THE CIP NETWORKS LIBRARY – Volume 4: *ControlNet™ Adaptation of CIP – Edition 1.7, April 2011*, available at <<http://www.odva.org>>

---



# British Standards Institution (BSI)

BSI is the national body responsible for preparing British Standards and other standards-related publications, information and services.

BSI is incorporated by Royal Charter. British Standards and other standardization products are published by BSI Standards Limited.

## About us

We bring together business, industry, government, consumers, innovators and others to shape their combined experience and expertise into standards-based solutions.

The knowledge embodied in our standards has been carefully assembled in a dependable format and refined through our open consultation process. Organizations of all sizes and across all sectors choose standards to help them achieve their goals.

## Information on standards

We can provide you with the knowledge that your organization needs to succeed. Find out more about British Standards by visiting our website at [bsigroup.com/standards](http://bsigroup.com/standards) or contacting our Customer Services team or Knowledge Centre.

## Buying standards

You can buy and download PDF versions of BSI publications, including British and adopted European and international standards, through our website at [bsigroup.com/shop](http://bsigroup.com/shop), where hard copies can also be purchased.

If you need international and foreign standards from other Standards Development Organizations, hard copies can be ordered from our Customer Services team.

## Subscriptions

Our range of subscription services are designed to make using standards easier for you. For further information on our subscription products go to [bsigroup.com/subscriptions](http://bsigroup.com/subscriptions).

With **British Standards Online (BSOL)** you'll have instant access to over 55,000 British and adopted European and international standards from your desktop. It's available 24/7 and is refreshed daily so you'll always be up to date.

You can keep in touch with standards developments and receive substantial discounts on the purchase price of standards, both in single copy and subscription format, by becoming a **BSI Subscribing Member**.

**PLUS** is an updating service exclusive to BSI Subscribing Members. You will automatically receive the latest hard copy of your standards when they're revised or replaced.

To find out more about becoming a BSI Subscribing Member and the benefits of membership, please visit [bsigroup.com/shop](http://bsigroup.com/shop).

With a **Multi-User Network Licence (MUNL)** you are able to host standards publications on your intranet. Licences can cover as few or as many users as you wish. With updates supplied as soon as they're available, you can be sure your documentation is current. For further information, email [bsmusales@bsigroup.com](mailto:bsmusales@bsigroup.com).

## BSI Group Headquarters

389 Chiswick High Road London W4 4AL UK

## Revisions

Our British Standards and other publications are updated by amendment or revision.

We continually improve the quality of our products and services to benefit your business. If you find an inaccuracy or ambiguity within a British Standard or other BSI publication please inform the Knowledge Centre.

## Copyright

All the data, software and documentation set out in all British Standards and other BSI publications are the property of and copyrighted by BSI, or some person or entity that owns copyright in the information used (such as the international standardization bodies) and has formally licensed such information to BSI for commercial publication and use. Except as permitted under the Copyright, Designs and Patents Act 1988 no extract may be reproduced, stored in a retrieval system or transmitted in any form or by any means – electronic, photocopying, recording or otherwise – without prior written permission from BSI. Details and advice can be obtained from the Copyright & Licensing Department.

## Useful Contacts:

### Customer Services

**Tel:** +44 845 086 9001

**Email (orders):** [orders@bsigroup.com](mailto:orders@bsigroup.com)

**Email (enquiries):** [cservices@bsigroup.com](mailto:cservices@bsigroup.com)

### Subscriptions

**Tel:** +44 845 086 9001

**Email:** [subscriptions@bsigroup.com](mailto:subscriptions@bsigroup.com)

### Knowledge Centre

**Tel:** +44 20 8996 7004

**Email:** [knowledgecentre@bsigroup.com](mailto:knowledgecentre@bsigroup.com)

### Copyright & Licensing

**Tel:** +44 20 8996 7070

**Email:** [copyright@bsigroup.com](mailto:copyright@bsigroup.com)



...making excellence a habit.™