

Programmable controllers —

Part 2: Equipment requirements and tests

The European Standard EN 61131-2 + Corrigendum:2003 has the status
of a British Standard

ICS 35.240.50; 25.040.40

National foreword

This British Standard is the official English language version of EN 61131-2 + Corrigendum:2003. It is identical with IEC 61131-2:2003, including Corrigendum 2003. It supersedes BS EN 61131-2:1995 which is withdrawn.

The UK participation in its preparation was entrusted by Technical Committee GEL/65, Measurement and control, to Subcommittee GEL/65/2, Elements of systems, which has the responsibility to:

- aid enquirers to understand the text;
- present to the responsible international/European committee any enquiries on the interpretation, or proposals for change, and keep the UK interests informed;
- monitor related international and European developments and promulgate them in the UK.

A list of organizations represented on this subcommittee can be obtained on request to its secretary.

Cross-references

The British Standards which implement international or European publications referred to in this document may be found in the *BSI Catalogue* under the section entitled “International Standards Correspondence Index”, or by using the “Search” facility of the *BSI Electronic Catalogue* or of British Standards Online.

This publication does not purport to include all the necessary provisions of a contract. Users are responsible for its correct application.

Compliance with a British Standard does not of itself confer immunity from legal obligations.

Summary of pages

This document comprises a front cover, an inside front cover, the EN title page, pages 2 to 117 and a back cover.

The BSI copyright notice displayed in this document indicates when the document was last issued.

Sideline in this document indicates the most recent changes by amendment.

Amendments issued since publication

Amd. No.	Date	Comments
15180	24 June 2004	Indicated by a sideline in the margin

This British Standard was published under the authority of the Standards Policy and Strategy Committee on 21 August 2003

© BSI 24 June 2003

ISBN 0 580 42492 8

EUROPEAN STANDARD

EN 61131-2

NORME EUROPÉENNE

EUROPÄISCHE NORM

August 2003

ICS 35.240.50; 25.040.40

Supersedes EN 61131-2:1994 + A11:1996 + A12:2000
Incorporates Corrigendum August 2003

English version

Programmable controllers
Part 2: Equipment requirements and tests
(IEC 61131-2:2003)

Automates programmables
Partie 2: Spécifications et essais des
équipements
(CEI 61131-2:2003)

Speicherprogrammierbare Steuerungen
Teil 2: Betriebsmittelanforderungen und
Prüfungen
(IEC 61131-2:2003)

This European Standard was approved by CENELEC on 2003-05-01. CENELEC members are bound to comply with the CEN/CENELEC Internal Regulations which stipulate the conditions for giving this European Standard the status of a national standard without any alteration.

Up-to-date lists and bibliographical references concerning such national standards may be obtained on application to the Central Secretariat or to any CENELEC member.

This European Standard exists in three official versions (English, French, German). A version in any other language made by translation under the responsibility of a CENELEC member into its own language and notified to the Central Secretariat has the same status as the official versions.

CENELEC members are the national electrotechnical committees of Austria, Belgium, Czech Republic, Denmark, Finland, France, Germany, Greece, Hungary, Iceland, Ireland, Italy, Lithuania, Luxembourg, Malta, Netherlands, Norway, Portugal, Slovakia, Spain, Sweden, Switzerland and United Kingdom.

CENELEC

European Committee for Electrotechnical Standardization
Comité Européen de Normalisation Electrotechnique
Europäisches Komitee für Elektrotechnische Normung

Central Secretariat: rue de Stassart 35, B - 1050 Brussels

Foreword

The text of document 65B/470A/FDIS, future edition 2 of IEC 61131-2, prepared by SC 65B, Devices, of IEC TC 65, Industrial-process measurement and control, was submitted to the IEC-CENELEC parallel vote and was approved by CENELEC as EN 61131-2 on 2003-05-01.

This European Standard supersedes EN 61131-2:1994 + A11:1996 + A12:2000.

The following dates were fixed:

- latest date by which the EN has to be implemented at national level by publication of an identical national standard or by endorsement (dop) 2004-02-01
- latest date by which the national standards conflicting with the EN have to be withdrawn (dow) 2006-05-01

Annexes designated "normative" are part of the body of the standard.

Annexes designated "informative" are given for information only.

In this standard, annexes C and ZA are normative and annexes A, B, D and E informative.

Annex ZA has been added by CENELEC.

The contents of the corrigendum of August 2003 have been included in this copy.

Endorsement notice

The text of the International Standard IEC 61131-2:2003 was approved by CENELEC as a European Standard without any modification.

In the official version, for Bibliography, the following notes have to be added for the standard indicated:

IEC 60038	NOTE	Harmonized as HD 472 S1:1989 (modified)
IEC 60112	NOTE	IEC 60112:2003 is harmonized as EN 60112:2003 (not modified)
IEC 60445	NOTE	Harmonized as EN 60445:2000 (not modified)
IEC 60947-5-2	NOTE	Harmonized as EN 60947-5-2:1998 (modified)
IEC 61140	NOTE	Harmonized as EN 61140:2002 (not modified)
IEC 62079	NOTE	Harmonized as EN 62079:2001 (not modified)

Corrigendum to IEC 61131-2:2003:

In Table 41, **replace** "Table 64" by "Table D.2".

In Table 56, **replace** "Figure 13" by "Figure 12".

CONTENTS

INTRODUCTION.....	8
1 General.....	9
1.1 Scope and object.....	9
1.2 Compliance with this standard.....	10
1.3 Normative references.....	10
2 Type tests.....	12
2.1 Equipment to be tested (equipment under test/EUT).....	12
2.2 Special features for immunity and EMC tests.....	14
2.3 Withstand test conditions.....	15
2.4 Verification procedure.....	15
2.5 Requirements for test programmes and proper functioning verification procedures (PFVPs) to be provided by the manufacturer.....	15
2.6 General conditions for tests.....	15
3 Terms and definitions.....	16
4 Normal service conditions and requirements.....	23
4.1 Climatic conditions and requirements.....	23
4.2 Mechanical service conditions and requirements.....	24
4.3 Transport and storage conditions and requirements.....	25
4.4 Electrical service conditions and requirements.....	26
4.5 Special conditions and requirements.....	27
5 Functional requirements.....	27
5.1 Functional power supply and memory back-up requirements.....	29
5.2 Digital I/Os.....	30
5.3 Analogue I/Os.....	37
5.4 Communication interface requirements.....	38
5.5 Main processing unit(s) and memory(ies) of the PLC-system requirements.....	38
5.6 Remote input/output stations (RIOSs) requirements.....	38
5.7 Peripherals (PADTs, TEs, HMIs) requirements.....	38
5.8 PLC-system self-tests and diagnostics requirements.....	39
5.9 Functional earthing.....	39
5.10 Mounting requirements.....	39
5.11 General marking requirements.....	40
5.12 Requirements for normal service and functional type tests and verifications.....	40
5.13 Requirements for information on normal service and function.....	40
6 Normal service and functional type tests and verifications.....	40
6.1 Climatic tests.....	40
6.2 Mechanical tests.....	42
6.3 Verification of special functional requirements for power ports and memory back-up – Special immunity limits for power ports.....	44
6.4 Verification of input/output requirements.....	49
6.5 Verification of communication interface requirements.....	52
6.6 Verification of MPU requirements.....	52
6.7 Verification of remote I/O stations.....	52
6.8 Verification of peripheral (PADTs, TEs, HMIs) requirements.....	53
6.9 Verification of PLC-system self-tests and diagnostics.....	53

6.10	Verification of markings and manufacturer's documentation.....	53
7	General information to be provided by the manufacturer	53
7.1	Information on type and content of documentation.....	53
7.2	Information on compliance with this standard	54
7.3	Information on reliability	54
7.4	Information on other conditions	54
7.5	Information on shipping and storage.....	54
7.6	Information on a.c. and d.c. power supply	54
7.7	Information on digital inputs (current sinking)	55
7.8	Information on digital outputs for alternating currents (current sourcing).....	55
7.9	Information on digital outputs for direct current (current sourcing)	56
7.10	Information on analogue inputs	56
7.11	Information on analogue outputs	57
7.12	Information on communication interfaces.....	58
7.13	Information on main processing unit(s) and memory(ies) of the PLC-system	58
7.14	Information on remote input/output stations (RIOSs)	59
7.15	Information on peripherals (PADTs, TEs, HMIs)	60
7.16	Information on self-tests and diagnostics.....	60
8	Electromagnetic compatibility (EMC) requirements	60
8.1	General	60
8.2	Emission requirements	61
8.3	EMC immunity requirements.....	61
8.4	Requirements for EMC tests and verifications	67
8.5	Requirements for information on EMC	67
9	Electromagnetic compatibility (EMC) type tests and verifications	67
9.1	Electromagnetic compatibility-related tests.....	67
9.2	Test environment.....	67
9.3	Measurement of radiated interference	68
9.4	Measurement of conducted interference	68
9.5	Electrostatic discharge	69
9.6	Radiofrequency electromagnetic field – Amplitude modulated	70
9.7	Power-frequency magnetic fields.....	70
9.8	Fast transient bursts.....	71
9.9	High-energy surges	72
9.10	Conducted radiofrequency interference	73
9.11	Damped oscillatory wave (for zone C only).....	74
9.12	Voltage drops and interruptions - Power port type tests and verifications	74
10	Electromagnetic compatibility (EMC) information to be provided by the manufacturer	75
11	Safety requirements	76
11.1	Protection against electrical shock	76
11.2	Protection against the spread of fire	81
11.3	Limited power circuits.....	81
11.4	Clearance and creepage distances requirements	82
11.5	Flame-retardant requirements for non-metallic materials	88
11.6	Temperature limits	89
11.7	Enclosures	89
11.8	Field-wiring terminals constructional requirements	90

11.9 Provisions for protective earthing	90
11.10 Wiring	91
11.11 Switching devices.....	92
11.12 Components	93
11.13 Battery requirements	93
11.14 Maximum voltage and minimum voltage	93
11.15 Markings and identification	93
11.16 Requirements for safety type tests and verifications	95
11.17 Requirements for safety routine tests and verifications	95
11.18 Requirements for information on safety	95
12 Safety type tests and verifications	96
12.1 Safety-related mechanical tests and verifications	96
12.2 Safety-related electrical tests	99
12.3 Single-fault condition test – General	103
13 Safety routine tests	104
13.1 Dielectric withstand test	104
13.2 Dielectric withstand verification test.....	104
13.3 Protective earthing test	105
14 Safety information to be provided by the manufacturer	105
14.1 Information on evaluation of enclosures for open equipment (power dissipation).....	105
14.2 Information on mechanical terminal connection	105
Annex A (informative) Illustration of PLC-system hardware definitions	106
Annex B (informative) Digital input standard operating range equations.....	107
Annex C (normative) Test tools.....	108
Annex D (informative) Zone C – EMC immunity levels	111
Annex E (informative) Overvoltage example.....	113
Annex ZA (normative) Normative references to international publications with their corresponding European publications	114
Bibliography.....	117
Figure 1 – EUT configurations	14
Figure 2 – Typical interface/port diagram of a PLC-system	28
Figure 3 – I/O Parameters.....	30
Figure 4 – U-I operation regions of current-sinking inputs	32
Figure 5 – Temporary overload waveform for digital a.c. outputs.....	34
Figure 6 – Temporary overload waveform for digital d.c. outputs.....	36
Figure 7 – Gradual shut-down/start-up test	45
Figure 8 – Fast supply voltage variation test	45
Figure 9 – Third harmonic immunity test	46
Figure 10 – Slow supply voltage variation test	48
Figure 11 – EMC immunity zones.....	62
Figure 12 – Impact withstand test procedure.....	96
Figure 13 – Dielectric withstand test procedures	101

Figure A.1 – Programmable controller system (PLC-system).....	106
Figure C.1 – Jointed test finger.....	108
Figure C.2 – 15 mm × 3 mm test pin	109
<i>Dimensions in millimeters</i>	109
Figure C.3 – 100 mm × 4 mm test pin	109
Figure C.4 – 100 mm × 3 mm test pin	110
Figure E.1 – Creepage distances of circuits where recurring peak voltages are generated	113
Table 1 – General conditions for tests.....	16
Table 2 – Operating ambient air temperature of PLC-systems.....	23
Table 3 – Sinusoidal vibration service conditions for PLC-systems	25
Table 4 – Free fall on concrete floor for portable and hand-held equipment	25
Table 5 – Free fall on concrete floor in manufacturer’s original packaging	26
Table 6 – Rated values and operating ranges of incoming power supply.....	29
Table 7 – Standard operating ranges for digital inputs (current sinking)	33
Table 8 – Rated values and operating ranges for current sourcing digital a.c. outputs	34
Table 9 – Rated values and operating ranges (d.c.) for current sourcing digital d.c. outputs	36
Table 10 – Rated values and impedance limits for analogue inputs.....	37
Table 11 – Rated values and impedance limits for analogue outputs.....	37
Table 12 – Dry-heat and cold withstand tests.....	41
Table 13 – Change of temperature, withstand and immunity tests	41
Table 14 – Cyclic (12 + 12) damp-heat test.....	42
Table 15 – Immunity vibration test	42
Table 16 – Immunity shock test.....	43
Table 17 – Free-fall immunity/withstand tests (portable and hand-held equipment)	43
Table 18 – Free-fall withstand test (units within manufacturer's original packaging)	43
Table 19 – Insertions/withdrawals of removable units	44
Table 20 – Voltage-ripple and frequency-range immunity test (1).....	44
Table 21 – Third harmonic immunity test.....	45
Table 22 – Gradual shut-down/start-up test	47
Table 23 – Supply voltage variation tests.....	47
Table 24 – Back-up duration withstand test.....	48
Table 25 – Change of energy source test.....	49
Table 26 – Overload and short-circuit tests for digital outputs	50
Table 27 – Emission limits	61
Table 28 – EMC immunity zones.....	63
Table 29 – Criteria to prove the performance of a PLC-system against EMC disturbances	63
Table 30 – Radiated immunity and enclosure ports (1) Conducted immunity, Zones A-B.....	64
Table 31 – Conducted immunity, Zone B.....	65
Table 32 – Conducted immunity, Zone A.....	66
Table 33 – Voltage drops and interruptions.....	67

Table 34 – Radiated emission measurement.....	68
Table 35 – Conducted emission measurement.....	68
Table 36 – Electrostatic discharge immunity test.....	69
Table 37 – Radiated electromagnetic field immunity test.....	70
Table 38 – Power frequency magnetic field immunity test.....	70
Table 39 – Fast transient burst immunity test.....	71
Table 40 – High-energy surge immunity test.....	72
Table 41 – Conducted RF immunity test.....	73
Table 42 – Damped oscillatory wave immunity test.....	74
Table 43 – Voltage drops and interruptions immunity test.....	75
Table 44 – Operator accessibility for open and enclosed equipment.....	79
Table 45 – Limits of output current and output power for inherently limited power sources.....	82
Table 46 – Limits of output current, output power and ratings for over-current protective devices for non-inherently limited power sources.....	82
Table 47 – Minimum clearances in air corresponding to overvoltage category II conditions (except for field-wiring terminals) for basic/supplementary insulation.....	83
Table 48 – Minimum clearances in air corresponding to overvoltage category II conditions (except for field-wiring terminals) for double /reinforced insulation.....	84
Table 49 – Minimum clearances in air at field-wiring terminals.....	84
Table 50 – Minimum clearances in air for micro-environment where the voltages are known and controlled.....	85
Table 51 – Classification of material group according to comparative tracking index (CTI).....	86
Table 52 – Minimum creepage distances for other than printed circuit boards (1).....	86
Table 53 – Minimum creepage distances for printed circuit boards (1), (6), (9) (basic and supplementary insulation).....	87
Table 54 – Minimum creepage distances related to recurring peak voltages on printed wiring boards without protective coating (1) (pollution degrees 1 and 2).....	88
Table 55 – Temperature limits.....	89
Table 56 – Impact withstand test (1).....	96
Table 57 – Operator accessibility tests (1).....	97
Table 58 – Dielectric withstand voltages for impulse a.c. power frequency and d.c. tests for basic/supplementary insulation (5).....	100
Table 59 – Dielectric withstand voltages for impulse a.c. power frequency and d.c. tests for double/reinforced insulation (5).....	101
Table 60 – Overload test circuit values.....	102
Table 61 – Endurance test circuit values.....	102
Table 62 – Routine dielectric withstand test (5).....	104
Table D.1 – Radiated immunity and enclosure ports (1) conducted immunity, Zone C.....	111
Table D.2 – Conducted immunity, Zone C.....	112

INTRODUCTION

This part of IEC 61131 constitutes Part 2 of a series of standards on programmable controllers and the associated peripherals and should be read in conjunction with the other parts of the series.

Where a conflict exists between this and other IEC standards (except basic safety standards), the provisions of this standard should be considered to govern in the area of programmable controllers and their associated peripherals.

Compliance with Parts 1 and 2 of this standard cannot be claimed unless the requirements of 7.2 of this part are met.

Service and physical environment requirements are specified in Clause 4. Functional requirements are specified in Clause 5. Electromagnetic compatibility requirements are specified in Clause 8. Safety requirements are specified in Clause 11.

Terms of general use are defined in Part 1 of this standard. More specific terms are defined in each part.

PROGRAMMABLE CONTROLLERS –

Part 2: Equipment requirements and tests

1 General

1.1 Scope and object

This Part of IEC 61131 specifies requirements and related tests for programmable controllers (PLC) and their associated peripherals (for example, programming and debugging tools (PADTs), human-machine interfaces (HMIs), etc.) which have as their intended use the control and command of machines and industrial processes.

PLCs and their associated peripherals are intended to be used in an industrial environment and may be provided as open or enclosed equipment. If a PLC or its associated peripherals are intended for use in other environments, then the specific requirements, standards and installation practices for those other environments must be additionally applied to the PLC and its associated peripherals.

This standard also applies to any products performing the function of PLCs and/or their associated peripherals.

Equipment covered in this standard is intended for use in overvoltage category II (IEC 60664-1) in low-voltage installations, where the rated mains supply voltage does not exceed a.c. 1 000 V r.m.s. (50/60 Hz), or d.c. 1 500 V. (If PLCs or their associated peripherals are applied in overvoltage category III installations, then additional analysis will be required to determine the suitability of the equipment for those applications.)

This standard does not deal with the functional safety or other aspects of the overall automated system. PLCs, their application programme and their associated peripherals are considered as components of a control system.

Since PLCs are component devices, safety considerations for the overall automated system including installation and application are beyond the scope of this standard. However, PLC safety as related to electric shock and fire hazards, electrical interference immunity and error detecting of the PLC-system operation (such as the use of parity checking, self-testing diagnostics, etc.), are addressed. Refer to IEC 60364 or applicable national/local regulations for electrical installation and guidelines.

The object of this standard is

- to establish the definitions and identify the principal characteristics relevant to the selection and application of PLCs and their associated peripherals;
- to specify the minimum requirements for functional, electrical, mechanical, environmental and construction characteristics, service conditions, safety, EMC, user programming and tests applicable to PLCs and the associated peripherals.

This Part also specifies

- a) service, storage and transportation requirements for PLCs and their associated peripherals (Clause 4);
- b) functional requirements for PLCs and their associated peripherals (Clause 5);
- c) EMC requirements for PLCs and their associated peripherals (Clause 8);
- d) safety requirements for PLCs and their associated peripherals (Clause 11);
- e) information that the manufacturer is required to supply (Clauses 7, 10 and 14);

- f) test methods and procedures that are to be used for the verification of compliance of PLCs and their associated peripherals with the requirements (Clauses 6, 9 and 12).

The tests are type tests or production routine tests, and not tests related to the ways PLC systems are applied.

1.2 Compliance with this standard

When compliance with this Part of IEC 61131 is indicated without qualification, compliance with all clauses, including all tests and verifications required in this part, must be verified. Moreover, the manufacturer's obligations expressed in this part are not waived if no type test is required, or if the test conditions are restricted for practical reasons.

When compliance with some portion of this Part of IEC 61131 is indicated, it is only necessary to verify compliance with those clauses against which the compliance claim is made. The manufacturer's obligations as indicated above are still applicable. The smallest unit of this part for compliance purposes shall be a clause, such as Clauses 5, 8 or 11.

Compliance with a portion of this Part of IEC 61131 is provided to facilitate efforts with respect to particular conformity assessment requirements (for example, Clause 8 as the compliance requirement for the EU electromagnetic compatibility directive or Clause 11 as the compliance requirement for the EU low-voltage directive).

Compliance with constructional requirements and with requirements for information to be provided by the manufacturer shall be verified by suitable examination, visual inspection and/or measurement.

All requirements not tested according to the clauses on tests and verifications shall be verifiable under a procedure to be agreed to by the manufacturer and the user.

The manufacturer shall provide, on request, compliance verification information for all requirements referenced in the claims of compliance with all or a portion of this Part of IEC 61131.

It is the manufacturer's responsibility to ensure that delivered PLC equipment and associated peripherals are equivalent to the sample(s) which have been type-tested according to this Part of IEC 61131 and therefore that they comply with all requirements of this part.

Significant modifications shall be indicated through the use of suitable revision level indexes and markings (see 5.11 and 11.15) and shall comply with this Part of IEC 61131.

NOTE A new type test may be required to confirm compliance.

Where the manufacturer is allowed to select among several options, he shall clearly specify in his catalogues and/or datasheets those to which any portion of the PLC-system equipment complies. This applies to severity classes of voltage drops (i.e. PS1 or PS2) and types of digital inputs (i.e. Type 1 or Type 3).

Text deleted

1.3 Normative references

The following referenced documents are indispensable for the application of this document. For dated references, only the edition cited applies. For undated references, the latest edition of the referenced document (including any amendments) applies.

IEC 60068-2-1:1990, *Environmental testing – Part 2: Tests – Tests A: Cold*

IEC 60068-2-2:1974, *Environmental testing – Part 2: Tests – Tests B: Dry heat*

- IEC 60068-2-6:1995, *Environmental testing – Part 2: Tests – Test Fc: Vibration (sinusoidal)*
- IEC 60068-2-14:1984, *Environmental testing – Part 2: Tests – Test N: Change of temperature*
- IEC 60068-2-27:1987, *Environmental testing – Part 2: Tests – Test Ea and guidance: Shock*
- IEC 60068-2-30:1980, *Environmental testing – Part 2: Tests – Test Db and guidance: Damp heat, cyclic (12 + 12-hour cycle)*
- IEC 60068-2-31:1969, *Environmental testing – Part 2: Tests – Test Ec: Drop and topple, primarily for equipment-type specimens*
- IEC 60068-2-32:1975, *Environmental testing – Part 2: Tests – Test Ed: Free fall (Procedure 1)*
- IEC 60364 (all parts), *Electrical installations of buildings*
- IEC 60417 (all parts), *Graphical symbols for use on equipment*
- IEC 60529:1989, *Degrees of protection provided by enclosures (IP Code)*
- IEC 60664-1:1992, *Insulation coordination for equipment within low-voltage systems – Part 1: Principles, requirements and tests*
- IEC 60664-3:1992, *Insulation coordination for equipment within low-voltage systems – Part 3: Use of coatings to achieve insulation coordination of printed board assemblies*
- IEC 60695-2-1 (all sheets), *Fire hazard testing – Part 2: Test methods – Section 1: Glow-wire test and methods*
- IEC 60707:1999, *Flammability of solid non-metallic materials when exposed to flame sources – List of test methods*
- IEC 60947-5-1:1997, *Low-voltage switchgear and controlgear – Part 5-1: Control circuit devices and switching elements – Electromechanical control circuit devices*
- IEC 60947-7-1:2002, *Low-voltage switchgear and controlgear – Part 7-1: Ancillary equipment – Terminal blocks for copper conductors*
- IEC 60950-1:2001, *Information technology equipment—Safety – Part 1: General requirements*
- IEC 61000-4-2:1995, *Electromagnetic compatibility (EMC) – Part 4-2: Testing and measurement techniques – Electrostatic discharge immunity test*
- IEC 61000-4-3:2002, *Electromagnetic compatibility (EMC) – Part 4-3: Testing and measurement techniques – Radiated radio-frequency electromagnetic field immunity test*
- IEC 61000-4-4:1995, *Electromagnetic compatibility (EMC) – Part 4: Testing and measurement techniques – Section 4: Electrical fast transient/burst immunity test*
- IEC 61000-4-5:1995, *Electromagnetic compatibility (EMC) – Part 4-5: Testing and measurement techniques – Surge immunity test*
- IEC 61000-4-6:1996, *Electromagnetic compatibility (EMC) – Part 4-6: Testing and measurement techniques – Immunity to conducted disturbances induced by radio-frequency fields*

IEC 61000-4-8:1993, *Electromagnetic compatibility (EMC) – Part 4-8: Testing and measurement techniques – Power frequency magnetic field immunity test*

IEC 61000-4-12:1995, *Electromagnetic compatibility (EMC) – Part 4-12: Testing and measurement techniques – Oscillatory waves immunity test*

IEC 61010-1:2001, *Safety requirements for electrical equipment for measurement, control, and laboratory use – Part 1: General requirements*

CISPR 11:1999, *Industrial, scientific and medical (ISM) radio-frequency equipment – Electromagnetic disturbance characteristics – Limits and methods of measurement*

CISPR 16-1:1999, *Specification for radio disturbance and immunity measuring apparatus and methods – Part 1: Radio disturbance and immunity measuring apparatus*

CISPR 16-2:1999, *Specification for radio disturbance and immunity measuring apparatus and methods – Part 2: Methods of measurement of disturbances and immunity*

2 Type tests

The object of this clause is to define how to verify compliance of the PLC and the associated peripherals with the requirements set forth in this part of IEC 61131. This compliance verification includes

- verification by type tests given in Clauses 6, 9 and 12,
- verification by suitable examination, visual inspection or/and measurement.

These tests are qualification tests, and not tests related to the ways PLCs are employed. According to the scope of this standard, the above compliance verification may not cover the verification of the ability of the PLC-system to satisfy the intended automated system requirements. Where needed, special tests, not covered by this standard, shall be agreed to by the manufacturer and the user.

In addition, routine tests are specified in Clause 13.

NOTE Peripherals, used in the same environment as the PLC-system, must meet the same requirements as the PLC-system.

2.1 Equipment to be tested (equipment under test/EUT)

PLC-systems span the range from stand-alone products to modular designs; this leads to an infinite variety of user-built actual PLC-system configurations. For obvious practical reasons, in most cases type tests cannot be conducted on EUT identical to user-built PLC-systems, and engineering judgement is necessary. Therefore, the manufacturer is required to define the EUTs and document the corresponding test plan and test programmes to meet the following principles.

Combination of tests/EUTs/test programmes shall be such that one may reasonably think that any configuration built by the user according to the manufacturer's specifications and installation instructions would pass satisfactorily the same tests, and will properly function in normal operation, which these tests are intended to reflect.

Unless otherwise specified in this standard, the manufacturer may elect to use various EUTs to achieve the objectives of a given type test.

If an EUT representing a basic PLC or a remote I/Os (RIOS) is of modular structure, it shall fulfil the following minimum requirement.

All types of modules shall be represented in 1 or several EUT configurations in which any mix of modules is permissible.

All types of modules shall be configured in the EUTs and tested at least once.

NOTE It may be appropriate to consider statistical criteria based on samples, for a large number of I/Os (for example, >100).

If there are too many families to be included into a single EUT, the manufacturer will define several EUTs.

For the type test of a family with very similar modules (i.e. modules using the same schematic and basic manufacturing and differing mainly by, for example, the number of inputs and outputs), the manufacturer may elect to include in the basic PLC-system only 1 arbitrarily chosen member of the family. If the type test is dependent on the differences between the modules, then a single family member may not be used.

Appropriate catalogued options, such as power supply units, application memory(ies), processing unit(s) etc. shall be used to build the relevant EUT(s).

If a local bus extension is part of the PLC-system and if its maximum cable length cable is less than, or equal to, 3 m, it is considered to be an internal PLC bus. As such, it should not be considered a port for test.

If a local bus extension is part of the PLC-system and is capable of driving cables with a length of >3 m, then only 1 end of the link is part of the EUT and it is considered as a communication port.

When new units/modules are introduced after initial release of a PLC-system catalogue, which has already been satisfactorily tested according to this standard, EUT(s) simpler than those originally used can be defined. This is only permissible if such EUTs and the associated test programmes provided by the manufacturer allow proper verification as if these new units/modules had been tested within the originally tested EUTs.

Unless otherwise specified in this standard, the manufacturer may elect either that each type test be conducted on a new EUT or that several type tests be performed successively on the same EUT.

Certain tests can be easily targeted at a single item, others are more appropriate to a set of items configured together. Equipment to be tested must reflect this need. See specific test clauses for recommendations for EUTs.

2.2 Special features for immunity and EMC tests

Interfaces/ports shown are meant to represent major/example links, not all links. Most EUTs will have multiple interface/ports active during testing.

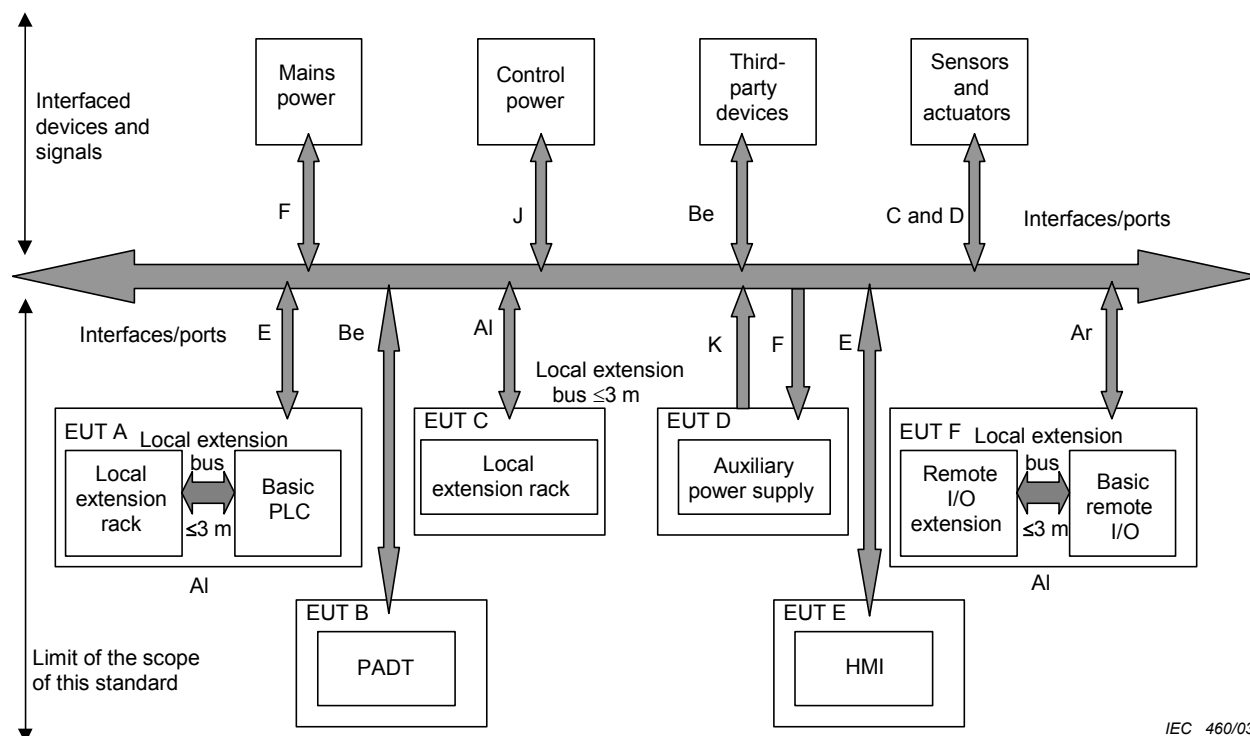

Figure 1 – EUT configurations

Each subpart of the PLC-system as shown in Figure 2 may constitute an EUT represented in Figure 1 as EUT A, B, C, D, E and/or F. To exercise the different ports of each EUT, the manufacturer may define subsystems and the different EUTs are tested in turn.

Only 1 subsystem is under test at any time, the others being considered as auxiliary equipment.

For instance, to achieve a given test on the EUT A, equipment of the other EUTs may be connected but are not in the test bed.

For example, to check the electrical interference immunity of the PLC-system, the manufacturer may choose between the following, as applicable:

- to build a single global EUT including the PADT/TE/RIOSs, and check the whole configuration; or
- to define a suite of simpler EUTs (for example, a PLC-system without any PADT/TE/RIOS, and a single PADT and a single RIOS and a single PADT and a single TE, or any other suite of partial combinations of them which make sense) but correspondingly exercise the appropriate ports of each EUT with an equipment part of the test bed (the laboratory equipment necessary to test the EUT) as would do the missing PADT/TE/RIOSs. For practical reasons, the manufacturer may elect to use actual PADTs/TEs/RIOSs to exercise the EUT ports.

At least 1 of each type or a representative number of I/O ports of the EUT must be connected and be functional.

A selection of the representative functional modes shall be made considering that only the most typical functions of the PLC can be tested.

2.3 Withstand test conditions

In general, the module which is in the manufacturer's catalogue should be tested alone, providing that mixing several modules does not affect the result of the test. Refer to those clauses dealing with withstand tests for specifics.

2.4 Verification procedure

Type tests shall be conducted on the EUT(s) defined in 2.1, unless otherwise specified.

For each test, the manufacturer shall

- specify how this configuration shall be installed and externally connected;
- provide the suitable test programmes which shall be run during the test;
- provide the proper operation verification procedure including the way to measure accuracy and temporary deviations of analogue I/Os.

The appropriate test programmes and proper functioning verification procedures provided by the manufacturer shall satisfy the requirements given in 2.5.

2.5 Requirements for test programmes and proper functioning verification procedures (PFVPs) to be provided by the manufacturer

During the type tests, there shall be no

- destruction of hardware, unless required by the test;
- modification of the operating system and test programmes and/or alteration of their execution;
- unintended modification of system and application data stored or exchanged;
- erratic or unintended behaviour of the EUT;
- deviation of the analogue I/Os out of the limits specified in item 4 of 710.2 and item 3 of 7.11.2.

All relevant functions and parts of the EUT (i.e. units and modules) shall be functioning in such a way that the information paths to/from these functions and parts are exercised.

All the I/O and communication channels of the EUT shall be exercised.

NOTE It is acceptable to apply statistical criteria based on samples, for large number of I/Os, etc. (for example, >100).

All external and internal product status information reporting means, such as displays, lamps, alarm signals, self-test result registers, shall be exercised. The test procedures shall include conditions to verify the related activities.

All various PLC-system operation modes significant for the user's implementation such as start-up and shut-down, cold/warm/hot restart, "normal run", "normal stop", "programme/monitor with PADTs", etc., as applicable, shall be verified for performance and behaviour.

Initialization and reset conditions of all system components shall be checked for controlled start-up and shut-down. The various modes, such as "run", "programme", "monitor", shall be verified for performance and behaviour.

Any special feature/performance not covered in this standard but necessary for the proper operation of the basic PLC-system shall be exercised and tested.

2.6 General conditions for tests

The tests shall be carried out in accordance with the appropriate test procedure.

The tests shall be carried out under the general test conditions given in Table 1, unless otherwise specified.

Unless otherwise specified, no sequence is imposed for type tests.

Table 1 – General conditions for tests

	Test conditions
Mains power supply	Rated voltage and frequency
Temperature	15 °C to 35 °C
Relative humidity	≤75 %
Barometric pressure	86 kPa to 106 kPa (650 mm Hg to 800 mm Hg)
Output loads	Outputs loaded to rated load
Pollution	Pollution degree 2

3 Terms and definitions

For the purposes of this Part of IEC 61131, the following terms and definitions, in addition to those given in IEC 61131-1, apply.

3.1

analogue input

device which converts a continuous signal to a discretely valued multi-bit binary number, for use by the PLC-system

3.2

analogue output

device which converts a multi-bit binary number from the PLC-system to a continuous signal

3.3

accessible

able to be touched by the jointed test finger or test pin, when installed as intended. See 12.1.2, 12.1.3 and Annex C

3.4

basic PLC (-system)

configuration which consists, at a minimum, of a processing unit, power supply and I/O. See Figure 2

3.5

battery

electrochemical energy source which may be rechargeable or non-rechargeable

3.6

clearance

shortest distance in air between two conductive parts

[IEC 60664-1]

3.7

coating, protective

covering of suitable insulating material that encloses the clearance and/or creepage distance of the printed wiring board and conforms to the surface of the board in such a manner that the environment is excluded and the clearance and/or creepage distance can withstand the required impulse and continuous potential

NOTE Coating is normally applied to exclude the effects of atmosphere and to increase the dielectric properties of the clearance and/or creepage distances that would not normally be adequate without coating. A less effective coating may exclude the atmosphere, but cannot be relied on to enhance the dielectric properties.

3.8 comparative tracking index (CTI)

numerical value of the maximum voltage at which a material withstands 50 drops of NH_4Cl solution (ammonia chloride) without tracking.

[IEC 60112]

3.9 creepage distance

shortest distance along the surface of the insulating material between two conductive parts

[IEV 60151-15-50]

3.10 current sinking

property of receiving current

3.11 current sourcing

property of supplying current.

3.12 digital input, type 1

device for sensing signals from mechanical contact switching devices, such as relay contacts, push-buttons, switches, etc. Converts an essentially two-state signal to a single-bit binary number

NOTE Type 1 digital inputs may not be suitable for use with solid-state devices such as sensors, proximity switches, etc.

3.13 digital input, type 2

device for sensing signals from solid-state switching devices such as 2-wire proximity switches. Converts an essentially 2-state signal to a single-bit binary number

NOTE 1 Two-wire proximity switches described here are designed to IEC 60947-5-2.

NOTE 2 This class could also be used for Type 1 or Type 3 applications.

3.14 digital input, type 3

device for sensing signals from solid-state switching devices such as 2-wire proximity switches. Converts an essentially 2-state signal to a single-bit binary number

NOTE 1 This class could also be used for Type 1 applications.

NOTE 2 Type 3 digital inputs offer lower power characteristics than Type 2 digital inputs. Generally, this allows much higher input channel densities per module or product. Type 3 differs from Type 2 in that it is compatible with those IEC 60947-5-2 devices that offer low current in the off state. See Table 7 for details of operating ranges. Proximity switch compatibility is such that a high percentage of proximity switches having Type 2 compatibility will also have Type 3 compatibility.

3.15 digital output

device which converts a single-bit binary number to a 2-state signal

3.16 earth

conducting mass of the Earth, whose electric potential at any point is conventionally taken as zero

3.17**EMC (electromagnetic compatibility)**

ability of an equipment or system to function satisfactorily in its electromagnetic environment without introducing intolerable electromagnetic disturbances to anything in that environment

[IEV 60161-01-07]

3.18**enclosed equipment**

equipment which is enclosed on all sides with the possible exception of its mounting surface to prevent personnel from accidentally touching live or moving parts contained therein and to protect the equipment against ingress of medium-size solid foreign bodies, and meeting requirements of mechanical strength, flammability, and stability (where applicable). Protection degree must be \geq IP20

3.19**enclosure**

housing affording the type and degree of protection suitable for the intended application

[IEV 60195-02-35]

3.20**equipment class**

class numbers designate the means by which electric shock protection is maintained in normal condition and single-fault conditions of the installed equipment

[IEC 61140]

3.21**equipment under test (EUT)**

representative configuration(s), as defined by the manufacturer, used for type tests (see Clause 2)

3.22**external wiring**

wiring of the PLC-system equipment, which is installed by the user

3.23**field wiring**

external wiring

3.24**functional earthing conductor**

conductor that is in electrical contact with, for example, Earth, for purposes of interference immunity improvement

3.25**hand-held equipment**

equipment which is intended to be held in one hand while being operated with the other hand

3.26**hazardous live**

capable of rendering an electric shock or electric burn in normal condition or single-fault condition.

NOTE See 11.1.1.1 for values applicable to normal condition and 11.1.1.2 for the values applicable to single-fault condition.

3.27**immunity (to a disturbance)**

ability of a device, equipment or system to perform without degradation in the presence of an electromagnetic disturbance

[IEV 60161-01-20]

NOTE Not used exclusively to refer to EMC in this standard. It may also refer, for example, to vibration, humidity, etc.

3.28**immunity type test (immunity test)**

type test verifying that the basic PLC-system operation is not altered by the application of specified influencing quantities that are intended to approximate normal operation

3.29**insulation**

NOTE 1 Insulation can be a solid, a liquid, a gas (for example, air), or any combination. [IEV 60151-03-30]

NOTE 2 (To) insulate – To prevent conduction between separate conductive bodies. [IEV 60151-03-28]

NOTE 3 (To) isolate – To disconnect completely a device or circuit from other devices or circuits.

To provide (by separation) a specified degree of protection from any live circuit. [IEV 60151-03-29]

3.29.1**basic insulation**

insulation of hazardous live parts, which provides basic protection against electric shock under fault-free conditions

[IEV 60195-06-06 and IEV 60195-06-01]

NOTE This concept does not apply to insulation used exclusively for functional purposes. Such insulation is referred to as functional insulation.

3.29.2**double insulation**

insulation comprising both basic insulation and supplementary insulation

[IEV 60195-06-08]

3.29.3**reinforced insulation**

insulation of hazardous live parts which provides a degree of protection against electric shock equivalent to double insulation

NOTE Reinforced insulation may comprise several layers which cannot be tested singly as basic or supplementary insulation.

[IEV 60195-06-09]

3.29.4**supplementary insulation**

independent insulation applied in addition to basic insulation, for fault protection

[IEV 60195-06-07]

3.30**interface**

shared boundary between a considered system and another system, or between parts of a system, through which information or electrical energy is conveyed

3.31**internal wiring**

wiring which is inside the PLC-system equipment, which is installed by the manufacturer

3.32**isolated (devices, circuits)**

devices or circuits without galvanic connection between them

3.33**live part**

conductor or conductive part intended to be energized in normal operation, including a neutral conductor, but by convention not a PEN conductor or PEM conductor or PEL conductor

NOTE 1 This concept does not necessarily imply a risk of electric shock. [IEV 60195-02-19]

NOTE 2 PEN conductor – conductor combining the functions of both a protective earthing conductor and a neutral conductor. [IEV 60195-02-12]

NOTE 3 PEM conductor – conductor combining the functions of a protective earthing conductor and a mid-point conductor. [IEV 60195-02-13]

NOTE 4 PEL conductor – conductor combining the functions of both a protective earthing conductor and a line conductor. [IEV 60195-02-14]

[IEV 60195-02-19]

3.34**mains power supply**

power from the conductors/mains of the permanent installation of the building at the supply voltage to the PLC-system

3.35**material group**

classification of insulating materials in terms of comparative tracking index (CTI) range (see 11.4.3)

3.36**micro-environment**

ambient conditions which surround the clearance or creepage distance being reviewed

NOTE The micro-environment of the clearance or creepage distance and not the environment of the equipment determines the effect of the insulation. The micro-environment may be better or worse than the environment of the equipment. It includes all factors influencing the insulation, such as climatic, electromagnetic, pollution, etc. (IEC 60664).

3.37**module**

part of the PLC-system containing an identified function(s) (MPU, analogue input, etc.), which may plug into a backplane or base

3.38**multi-channel module**

module containing multiple input and/or output signal interfaces. These signal interfaces could be isolated or not isolated from each other

3.39**normal use**

operation, including stand-by, according to the instructions for use or for the obvious intended purpose

NOTE Normal service conditions are stated in Clause 4.

3.40**normal condition**

condition in which all means for protection against hazards are intact that is, a fault-free condition

3.41**open equipment**

equipment that may have live electrical parts accessible, for example, a main processing unit. Open equipment is to be incorporated into other assemblies manufactured to provide safety

3.42**operator**

person commanding and monitoring a machine or process through an HMI connected to the PLC. The operator does not change the PLC hardware configuration, software or the application programme. A PLC is not intended for use by untrained personnel. The operator is assumed to be aware of the general hazards in an industrial environment

3.43**overvoltage category (of a circuit or within an electrical system)**

NOTE 1 classification based on limiting (or controlling) the values of prospective transient overvoltages occurring in a circuit (or within an electrical system having different nominal voltages) and depending upon the means employed to influence the overvoltages.

[IEC 60664-1]

NOTE 2 In an electrical system, the transition from 1 overvoltage category to another of lower category is obtained through appropriate means complying with interface requirements. These interface requirements may be an overvoltage protective device or a series-shunt impedance arrangement capable of dissipating, absorbing, or diverting the energy in the associated surge current, to lower the transient overvoltage value to that of the desired lower overvoltage category.

Equipment covered in this standard is intended for use in overvoltage category II.

3.44**permanent installation**

portion of the PLC-system which is required to perform the intended application function

NOTE See Annex A.

3.45**pollution degree (in the micro-environment)**

for the purpose of evaluating clearances and creepage distances, 3 degrees of pollution in the micro-environment are established

NOTE 1 The conductivity of a polluted insulation is due to the deposition of foreign matter and moisture.

NOTE 2 The minimum clearances given for pollution degrees 2 and 3 are based on experience rather than on fundamental data.

3.45.1**pollution degree 1**

no pollution or only dry, non-conductive pollution occurs. The pollution has no influence

3.45.2**pollution degree 2**

normally, only non-conductive pollution occurs. Occasionally, however, a temporary conductivity caused by condensation must be expected

3.45.3**pollution degree 3**

conductive pollution occurs, or dry, non-conductive pollution occurs which becomes conductive due to condensation, which is expected

3.46**port**

interface

NOTE Most commonly used with respect to EMC.

3.47**portable equipment**

enclosed equipment that is moved while in operation or which can easily be moved from one place to another while connected to the supply

NOTE Examples are programming and debugging tools (PADTs) and test equipment (TE).

3.48**protective conductor**

conductor provided for purposes of safety, for example, protection against electric shock

[IEV 60195-02-09]

3.49**protective extra-low voltage (PELV) circuit**

electrical circuit in which the voltage cannot exceed a.c. 30 V r.m.s., 42,4 V peak or d.c. 60 V in normal and single-fault condition, except earth faults in other circuits.

A PELV circuit is similar to an SELV circuit that is connected to protective earth

3.50**protective impedance**

single component regarded as fault-free, a combination of components, or a combination of basic insulation and a current- or voltage-limiting device, the impedance, construction and reliability of which are such that when connected between parts which are hazardous live and accessible conductive parts, it provides protection to the extent required by this standard in normal and single-fault condition

3.51**recurring peak voltage**

peak value of a generated voltage whose characteristic is recurring at some specified period

3.52**routine test**

conformity test made on each individual item during or after manufacture

[IEV 60151-16-17]

3.53**safety extra-low voltage circuit (SELV circuit)**

electrical circuit in which the voltage cannot exceed a.c. 30 V r.m.s., 42,4 V peak or d.c. 60 V in normal and single-fault condition, including earth faults in other circuits.

An SELV circuit is not connected to protective earth

3.54**service personnel**

person changing or repairing the PLC hardware configuration or the application programme

The service person may also install software updates provided by the manufacturer. They are assumed to be trained in the programming and operation of the PLC equipment and its use.

They are persons having the appropriate technical training and experiences necessary to be aware of hazards – in particular, electrical hazards – to which they are exposed in performing a task and of measures to minimize danger to themselves or to other persons or to the equipment.

3.55**total output current (of an output module)**

current that a multi-channel module operating at the most adverse combination of normal operation can supply without any part of it (insulation, terminals, exposed conductive parts, etc.) exceeding the specified temperature limits

NOTE For a multi-channel module, the total output current is generally less than the sum of the output currents of the channels.

3.56

type test

conformity test made on one or more items representative of the production

[IEV 60151-16-16]

3.57

unit

integral assembly (which may consist of modules plugged in or otherwise connected within the assembly) connected to other units within the system by means of cables for permanently installed units and cables or other means for portable units

3.58

withstand type test (withstand test)

type test verifying that the application of more severe influencing quantities to the basic PLC-system does not impair its ability to assume its intended mission

3.59

working voltage

highest value of the a.c. (r.m.s) or d.c. voltage across any particular insulation which can occur when the equipment is supplied at rated voltage (U_e)

Transients are disregarded.

Both open-circuit conditions and normal use are taken into account.

4 Normal service conditions and requirements

It is the user's responsibility to ensure that the equipment service conditions are not exceeded. The PLC and PLC-system is intended to be used in an industrial environment.

The user must ensure the installation conditions match the environmental conditions given in this standard.

4.1 Climatic conditions and requirements

4.1.1 Operating ambient air temperature

The equipment shall be suitable for the operating temperature ranges given by the following Table 2.

Table 2 – Operating ambient air temperature of PLC-systems

Temperature range	Type of limit	Enclosed equipment (ventilated/non-ventilated)		Open equipment
		Permanent installation	Non-permanent installation	Permanent installation
	Max.	40 °C	40 °C	55 °C
	Min.	5 °C	5 °C	5 °C
Average temperature over 24 h	Max.	35 °C	35 °C	50 °C

For enclosed non-ventilated equipment that is cooled by natural air convection, the equipment ambient air temperature is the room temperature 1 m away from the surface of the enclosure on a horizontal plane located at the vertical mid-point of the enclosure.

For enclosed ventilated equipment, the equipment ambient temperature is the temperature of the incoming air.

For open equipment, the ambient air temperature is the temperature of the incoming air immediately below the equipment.

No forced external cooling is assumed. Open peripherals, which are intended to be permanently installed as part of the PLC-system, shall meet the operating temperature range of the PLC.

Some types of equipment (for example, panel-mounted HMI, etc.) can use a combination of open and enclosed characteristics.

Requirements of this subclause are verified in accordance with 6.1.1 and 6.1.2.

4.1.2 Relative humidity

The equipment shall be suitable for a relative humidity level from 10 % to 95 %, non-condensing.

Requirements of this subclause are verified in accordance with 6.1.3.

4.1.3 Altitude

The equipment shall be suitable for operation up to 2 000 m.

No test required.

4.1.4 Pollution degree

Where not otherwise specified by the manufacturer the equipment is designed for use in pollution degree 2.

4.2 Mechanical service conditions and requirements

Vibration, shock and free-fall conditions vary widely depending on the installation and environment and are very difficult to specify.

For the purpose of this standard, the service conditions are indirectly defined by the following requirements which apply to fixed equipment as well as to unpackaged portable and hand-held equipment (see exceptions in 4.2.2). They do not apply to equipment containing assemblies other than PLC-systems and/or associated peripherals.

Experience shows that equipment meeting these requirements is suitable for industrial use on stationary installations.

Fixed equipment is that which is part of the permanent installation.

4.2.1 Vibrations

Immunity requirements are:

Table 3 – Sinusoidal vibrations service conditions for PLC-systems

Frequency range Hz	Continuous	Occasional
$5 \leq f < 9$	1,75 mm amplitude	3,5 mm amplitude
$9 \leq f \leq 150$	0,5 g constant acceleration	1,0 g constant acceleration

Vibration is applicable to each 3 mutually perpendicular axes.

The manufacturer shall specify the method of mounting portable and hand-held peripherals on the test equipment.

Requirements of this subclause are verified in accordance with 6.2.1.

4.2.2 Shock

Immunity requirements are occasional excursions to 15 g, 11 ms, half-sine, in each of 3 mutually perpendicular axes.

Devices containing CRTs are excluded from this requirement.

Electromechanical relays may temporarily respond to 15 g shocks. Temporary malfunctioning is allowed during the test, but equipment should be fully functional after the test.

Requirements of this subclause are verified in accordance with 6.2.2.

4.2.3 Free falls (portable and hand-held equipment)

Immunity requirements for free falls are:

Table 4 – Free fall on concrete floor for portable and hand-held equipment

	Portable and hand-held (any weight) (withstand)	Hand-held (any weight) (immunity)	Normative items
Random drops	–	1 000 mm; 2 trials	(1), (2), (4)
Flat drops	100 mm; 2 trials	–	(1), (4)
Supported drops	30° or 100 mm; 2 trials	–	(1), (3), (4)

(1) Caution: temporary malfunctioning is allowed at the impact, but equipment shall be fully functional after the test. Therefore, if equipment is operating during the fall, erroneous operation could be introduced upon impact which may require operator correction.

(2) From prescribed altitude (normal position of use) Table 17.

(3) See Table 17.

(4) Random drops are drops on any edge, surface or corner. Flat drops are only on surfaces. Supported drops are only on edges.

Requirements of this subclause are verified in accordance with 6.2.3.

4.3 Transport and storage conditions and requirements

The following requirements apply to PLC units placed within manufacturer's original packaging.

Transport and storage of unpackaged portable equipment should not exceed the requirements of 4.2.

When components are included in the equipment that have particular limitations (for example, CMOS components, batteries, etc.), the manufacturer shall specify the arrangements to be made for transport and storage.

4.3.1 Temperature

The allowable temperature range is $-40\text{ }^{\circ}\text{C}$ to $+70\text{ }^{\circ}\text{C}$.

The temperature range $-25\text{ }^{\circ}\text{C}$ to $+70\text{ }^{\circ}\text{C}$ is acceptable, but is not recommended for future designs.

Requirements of this subclause are verified in accordance with 6.1.1.

The relative humidity range is 10 % to 95 %, non-condensing.

Requirements of this subclause are verified in accordance with 6.2.3.

4.3.2 Relative humidity

The relative humidity range is 10 % to 95 %, non-condensing.

Requirements of this subclause are verified in accordance with 6.1.3.

4.3.3 Altitude

The design atmospheric pressure for transportation shall be equivalent to 0-3 000 m altitude (minimum 70 kPa).

No test required.

4.3.4 Free falls (PLC units in manufacturer's original packaging)

Withstand requirements for PLC units within manufacturer's original packaging are given in Table 5 below. After the test, they shall be fully functional and shall show no evidence of physical damage.

Table 5 – Free fall on concrete floor in manufacturer's original packaging

Shipping weight with packaging kg	Random free-fall drop height mm		Number of falls
	With shipping package	With product package	
<10	1000	300	5
10 to 40	500	300	5
>40	250	250	5

Requirements of this subclause are verified in accordance with 6.2.4.

4.3.5 Other conditions

The user should reach agreement with the manufacturer for any mechanical conditions that are not specified in this standard. This may include items such as extra-low temperature storage, higher altitude transportation, etc.

4.4 Electrical service conditions and requirements

4.4.1 AC and d.c. mains power supply

Refer to 5.1.1.

4.4.2 Overvoltage category, control of transient overvoltages

The nature of the installation shall be such that overvoltage category II conditions shall not be exceeded.

Transient overvoltages at the point of connection to the mains power supply shall be controlled not to exceed overvoltage category II, i.e. not higher than the impulse voltage corresponding to the rated voltage for basic insulation. The equipment or the transient suppression means shall be capable of absorbing the energy in the transient.

4.4.3 Non-periodic overvoltages

In the industrial environment, non-periodic overvoltage peaks may appear on mains power supply lines as a result of power interruptions to high-energy equipment (for example, blown fuse on 1 branch in a 3-phase system). This will cause high current pulses at relatively low voltage levels (approximately $2 \times U_{\text{peak}}$). The user shall take the necessary steps to prevent damage to the PLC-system (for example, by interposing a transformer).

4.5 Special conditions and requirements

When the service conditions are more severe than those given in 4.1, 4.2, 4.3 and 4.4 or other adverse environmental conditions exist (for example, air pollution by dust, smoke, corrosive or radioactive particles, vapours or salts, attack by fungi, insects or small animals), the manufacturer should be consulted to determine suitability of the equipment or the steps to be taken.

5 Functional requirements

A typical PLC-system and its interfaces/ports are shown in Figure 2.

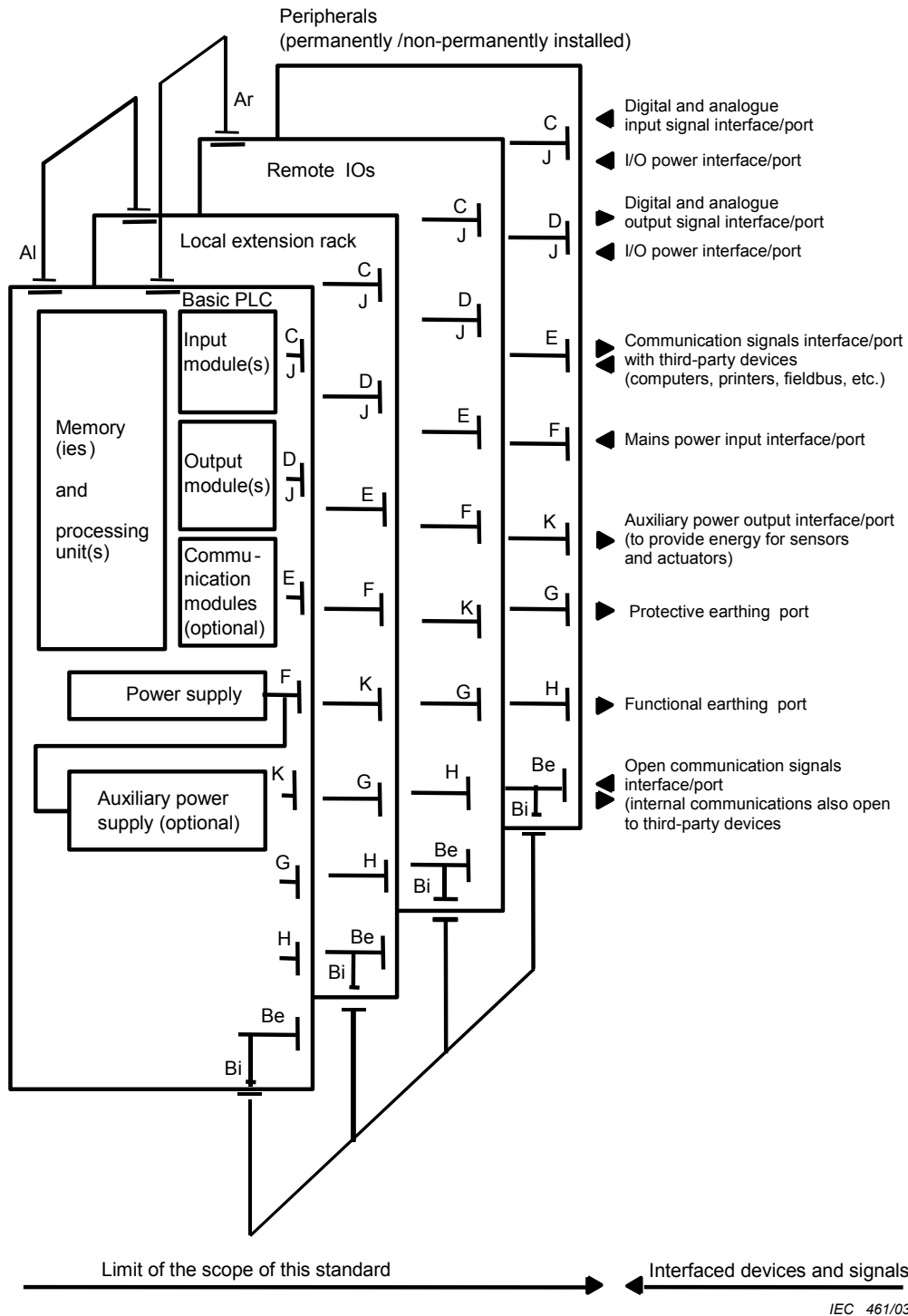

Key

- Al Communication interface/port for local I/O
- Ar Communication interface/port for remote I/O station
- Be Open communication interface/port also open to third-party devices (for example, personal computer used for programming instead of a PADT)
- Bi Internal communication interface/port for peripherals
- C Interface/port for digital and analogue input signals
- D Interface/port for digital and analogue output signals
- E Serial or parallel communication interfaces/ports for data communication with third-party devices
- F Mains-power interface/port. Devices with F ports have requirements on keeping downstream devices intelligent during power up, power down and power interruptions.
- G Port for protective earthing
- H Port for functional earthing
- J I/O power interface/port used to power sensors and actuators.
- K Auxiliary power output interface/port

Figure 2 – Typical interface/port diagram of a PLC-system

IEC 461/03

5.1 Functional power supply and memory back-up requirements

5.1.1 AC and d.c. power supply

Requirements of this subclause are verified in accordance with 6.3.1, 6.3.2 and 6.3.3.

5.1.1.1 Rated values and operating ranges

Incoming power supplies to the PLC-system and to the externally powered I/O modules shall be as shown in Table 6.

Table 6 – Rated values and operating ranges of incoming power supply

Voltage		Frequency		Recommended use (R)		Normative items and note (3)	
Rated (U_e)	Tolerance (min./max.)	Rated (F_n)	Tolerance (min./max.)	Power supply	I/O signals (5)		
DC 24 V	-15 %/+20 %			R	R	(1)	
DC 48 V				R	R	(1), (2)	
DC 125 V				–	–	–	
AC 24 V r.m.s.	-15 %/+10 %	50 Hz or 60 Hz	-6 %/+4 %	–	–	(Note)	
AC 48 V r.m.s.				–	–	(Note)	
AC 100 V r.m.s.				R	R	–	
AC 110 V r.m.s.				R	R	(Note)	
AC 120 V r.m.s.				R	R	–	
AC 200 V r.m.s.				R	R	(Note)	
AC 230 V r.m.s.				R	–	(Note), (4)	
AC 240 V r.m.s.							
AC 400 V r.m.s.							

(1) In addition to the voltage tolerances, a total a.c. component having a peak value of 5 % of the rated voltage is allowed. The absolute limits are d.c. 30/19,2 V for d.c. 24 V and d.c. 60/38,4 V for d.c. 48 V.

(2) See Note 5 of Table 7 if Type 2 digital inputs are likely to be used.

(3) For incoming voltages other than those given in the table such as d.c. 110 V etc., the tolerances given in the table and Note 1 apply. These voltage tolerances shall be used to calculate the input limits of Table 7, using the equations in Annex B.

(4) Three-phase supply.

(5) For power supplies for analogue I/Os, see item 5 of 7.10.3 and item 3 of 7.11.3.

NOTE The rated voltages are derived from IEC 60038.

Requirements of this subclause are verified in accordance with 6.3.1.

5.1.1.2 Voltage harmonics

AC voltage is in terms of the total r.m.s. voltage values measured at the point of entry to the equipment.

Total r.m.s. content of true harmonics (integral multiple of nominal frequency) less than 10 times nominal frequency may reach 10 % of the total voltage. Harmonic and other frequency content for higher frequencies may reach 2 % of the total voltage. However, to provide constant comparative results, the equipment shall be tested at the third harmonic only (10 % at 0° and at 180° phase angle).

The total content of harmonics of the power supply to the PLC-system may be affected when the energy source output impedance is relatively high with regard to the input impedance of the PLC-system power supply; sizing a dedicated power source such as an inverter for a PLC-system may require an agreement between the user and the manufacturer. The use of line conditioner should be considered. See IEC 61131-4.

Requirements of this subclause are verified in accordance with 6.3.1.2.

5.1.2 Memory back-up

Power back-up for volatile memories shall be capable of maintaining stored information for at least 300 h under normal use, and 1 000 h at a temperature not greater than 25 °C when the energy source is at rated capacity. (For power back-up needing replacement, the rated capacity is the value used to designate the procedure and time interval for replacement.)

The manufacturer should specify storage time information relative to volatile memory if different from stated durations.

It shall be possible to change or refresh power back-up without loss of data in the backed-up portions of memory. (See also 4.3, 7.6 item 8 and 7.13 item 4.)

If a memory back-up battery is provided, a warning of "low battery voltage" shall be provided.

Requirements of this subclause are verified in accordance with 6.3.4.

5.2 Digital I/Os

Figure 3 gives an illustration of definitions of some I/O parameters.

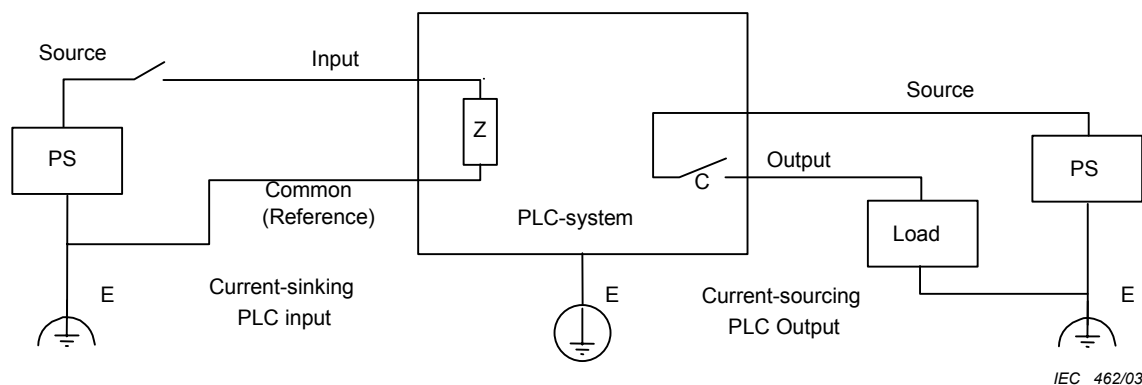

IEC 462/03

Key

- C Output
Mechanical or static contact (for example dry relay contact, triac, transistor or equivalent).
- E Earthings
The earths shown are original.
Earthing is dependent on national regulations and/or application needs.
- Z Input
Input impedance
- PS External power supplies

NOTE Some applications may use only 1 PS common to inputs, outputs and PLC-system.

Figure 3 – I/O Parameters

Digital I/Os shall comply with the following requirements.

The PLC-system shall be provided with at least 1 type of input interface and 1 type of output interface among those defined respectively in 5.2.1, 5.2.2 and 5.2.3.

Digital inputs shall comply with the requirements of the standard voltage ratings given in 5.2.1. Non-standard voltage digital inputs should be in accordance with the design equation given in Annex B.

Digital outputs shall comply with the requirements of the standard ratings given in 5.2.2.1 for a.c. or 5.2.3.1 for d.c..

It shall be possible to interconnect inputs and outputs by means of a correct selection of the above digital I/Os, resulting in proper PLC-system operation. (Additional external load shall be specified by the manufacturer if necessary.)

It shall be possible to feed isolated multi-channel a.c. input modules from different phases and the modules shall then comply with the maximum voltage difference likely to occur between phases, or the user manual shall include a note indicating that all channels must be fed from the same phase.

If a multi-channel a.c. circuit is intended for multi-phase use, the circuit shall comply with the clearance and creepage distance requirements and the dielectric test corresponding to the voltage between phases.

NOTE 1 Current-sourcing inputs and current-sinking outputs which may be required for certain applications are not covered in this Part of IEC 61131. Special care should be exercised in their use. (Where positive logic, current-sinking inputs and current-sourcing outputs are used, any short-circuit to the reference potential and wire-breakage are interpreted by the inputs and loads as the "off state"; on the other hand, for current-sourcing inputs and current-sinking outputs, earth faults are interpreted as the "on state") (See Figure 3.)

NOTE 2 A PLC-system may be offered with interfaces that are not covered in this standard, i.e., interfaces for TTL and CMOS circuits, etc. In such a case, the manufacturer's data shall give all relevant information to the user.

5.2.1 Digital inputs (current sinking)

Requirements of this subclause are verified in accordance with 6.4.2.

5.2.1.1 Terminology (U/I operation regions)

Figure 4 represents graphically the limits and operating ranges which are used herein to characterize current sinking digital input circuits.

The operating region consists of "on region", "transition region" and "off region". It is necessary to exceed both UT min. and IT min. to leave the "off region", and to exceed IH min. before UH min. to enter the "on region": all input U-I curves shall remain within these boundary conditions. The region below zero volts is a valid part of the "off region" for d.c. inputs only.

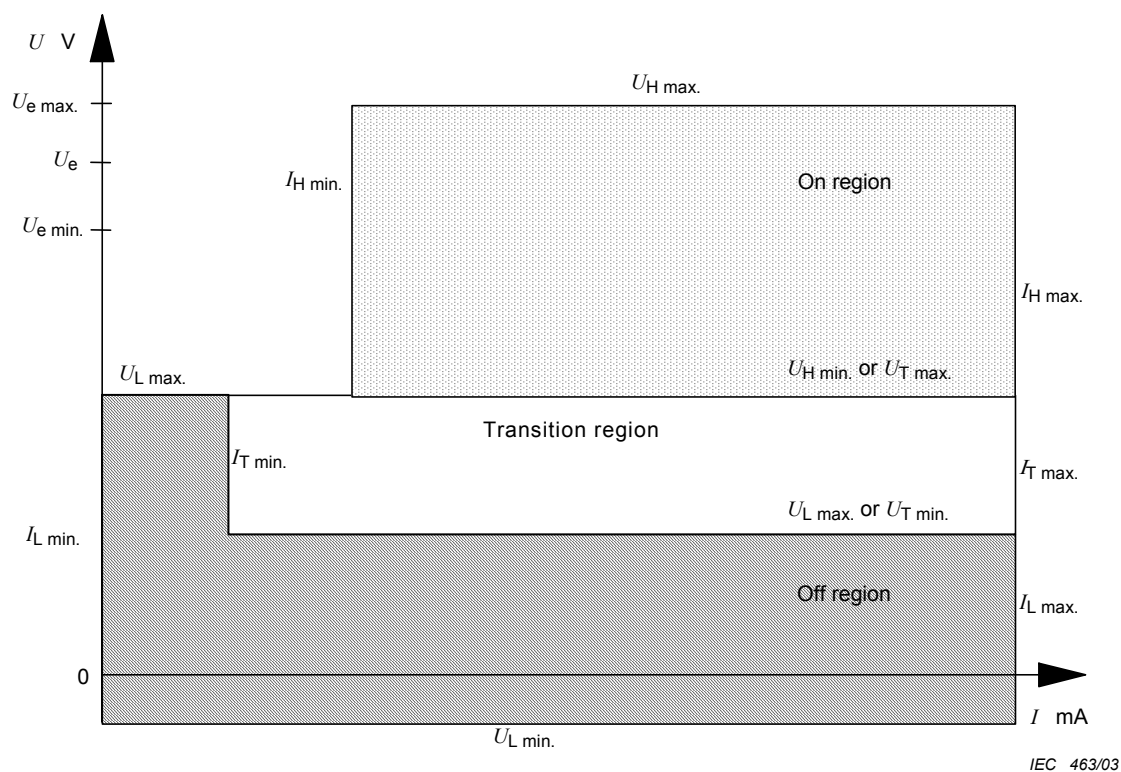

IEC 463/03

NOTE **side rule on figure**

U_{Hmax} and U_{Hmin} are the voltage limits for the on conditions (state 1)

I_{Hmax} and I_{Hmin} are the current limits for the on conditions (state 1)

U_{Tmax} and U_{Tmin} are the voltage limits for the transition state (on or off)

I_{Tmax} and I_{Tmin} are the current limits for the transition state (on or off)

U_{Lmax} and U_{Lmin} are the voltage limits for the off conditions (state 0)

I_{Lmax} and I_{Lmin} are the current limits for the off conditions (state 0)

U_{Lmax} equals U_{Hmin} to I_{Tmin} and equals U_{Tmin} above I_{Tmin}

U_e , $U_{e max}$ and $U_{e min}$ are the rated voltage and its limits for the external power supply voltage

Figure 4 – U-I operation regions of current-sinking inputs

5.2.1.2 Standard operating ranges for digital inputs (current sinking)

Current-sinking digital inputs shall operate within the limits presented in Table 7.

Table 7 – Standard operating ranges for digital inputs (current sinking)

Rated voltage U_e	Rated frequency F_n Hz	Type of limit	Type 1 limits (7)						Type 2 limits (7), (Note)						Type 3 limits (7)						Normative items
			State 0		Transition		State 1		State 0		Transition		State 1		State 0		Transition		State 1		
			UL V	IL mA	UT V	IT mA	UH V	IH mA	UL V	IL mA	UT V	IT mA	UH V	IH mA	UL V	IL mA	UT V	IT mA	UH V	IH mA	
DC 24V	---	Max. Min.	15/5 -3	15 ND	15 5	15 0,5	30 15	15 2	11/5 -3	30 ND	11 5	30 2	30 11	30 6	11/5 -3	15 ND	11 5	15 1,5	30 11	15 2	(1), (2), (4), (5)
DC 48V	---	Max. Min.	34/10 -6	15 ND	34 10	15 0,5	60 34	15 2	30/10 -6	30 ND	30 10	30 2	60 30	60 6	30/10 -6	15 ND	30 10	15 1,5	60 30	15 2	(1), (2), (4)
AC 24V V r.m.s.	50/60	Max. Min.	14/5 0	15 0	14 5	15 1	27 14	15 2	10/5 0	30 0	10 5	30 4	30 10	27 6	10/5 0	15 0	10 5	15 2	27 10	15 5	(1), (3)
AC 48 V r.m.s.	50/60	Max. Min.	34/10 0	15 0	34 10	15 1	53 34	15 2	29/10 0	30 0	29 10	30 4	53 29	30 6	30/10 0	15 0	30 10	15 2	53 30	15 5	(1), (3)
AC 100 AC 110 AC 120 V r.m.s.	50/60	Max. Min.	79/20 0	15 0	79 20	15 1	1,1 U_e 79	15 2	74/20 0	30 0	74 20	30 4	1,1 U_e 74	30 6	74/20 0	15 0	74 20	15 2,5	1,1 U_e 74	15 5	(1), (3), (4), (6)
AC 200 AC 230 AC 240 V r.m.s.	50/60	Max. Min.	164/40 0	15 0	164 40	15 2	1,1 U_e 164	15 3	159/40 0	30 0	159 40	30 5	1,1 U_e 159	30 7	159/40 0	15 0	159 40	15 2,5	1,1 U_e 159	15 5	(1), (3), (4), (6)

(1) All logic signals are in positive logic. Open inputs shall be interpreted as state 0 signal. See Annex B for equations and assumptions used in developing values in this table and for additional comments.
(2) The given voltage limits include all alternating voltages components.
(3) Static switches may affect the total r.m.s. content of true harmonics of the input signals and therefore affect the compatibility of the input interface with proximity switches, especially for Type 2, a.c. 24 V r.m.s. See 5.1.1.1 for requirements.
(4) Recommended for common usage and future designs.
(5) The minimum external power supply voltage for Type 2, d.c. 24 V inputs connected to 2-wire proximity switches should be higher than d.c. 20 V or $U_{H \min}$ lower than d.c. 11 V to allow sufficient safety margin.
(6) As allowed by current technology, and to encourage the design of single input modules compatible with all commonly used rated voltages, limits are absolute and independent of rated voltage (except $U_{H \max}$) and based on equations given in Annex B and respectively a.c. 100 V r.m.s. and a.c. 200 V r.m.s.
(7) See definitions 3.12, 3.13 and 3.14.
NOTE Compatibility with 2-wire proximity switches according to IEC 60947-5-2 is possible with Type 2. See also (3).
ND = Not defined.

5.2.1.3 Additional requirements

Each input channel shall be provided with a lamp or equivalent means to indicate the state 1 condition when the indicator is energized.

5.2.2 Digital outputs for alternating currents (current sourcing)

Requirements of this subclause are verified in accordance with 6.4.3.

5.2.2.1 Rated values and operating ranges (a.c.)

Digital a.c. outputs shall comply with the ratings given in Table 8, at the output voltage(s) stated by the manufacturer according to 5.1.1.1.

Table 8 – Rated values and operating ranges for current sourcing digital a.c. outputs

Rated current (state 1)	I_e A	0,25	0,5	1	2	Normative items	
Current range for state 1 (continuous at max. voltage)	Min. (mA)	10 [5]	20	100	100	(1), (2)	
	Max. (A)	0,28	0,55	1,1	2,2	(1)	
Voltage drop, U_d for state 1	U_d	–	–	–	–	–	
	– Non protected output	Max. (V)	3	3	3	3	(1)
	– Protected and short-circuit proof	Max. (V)	5	5	5	5	(1)
Leakage current for state 0		–	–	–	–	–	
	– Solid-state outputs	Max. (mA)	5 [3]	10	10	10	(1), (2), (3)
	– Electromechanical outputs	Max. (mA)	2,5	2,5	2,5	2,5	(1), (3)
Repetition rate for temporary overload (see Figure 5)	Operating cycle time	–	–	–	–		
	– Solid-state outputs	(s)	–	–	–	–	
	– Relay-based outputs	Max.	1	2	2	2	
	Max.	10	10	10	10		

(1) RMS currents and voltages.

(2) Figures in square brackets apply to a module not equipped with RC network or equivalent surge suppressers. All other values apply to modules with suppression.

(3) Leakage current for solid-state outputs greater than 3 mA imply the use of additional external loads to drive Type 2 digital inputs.

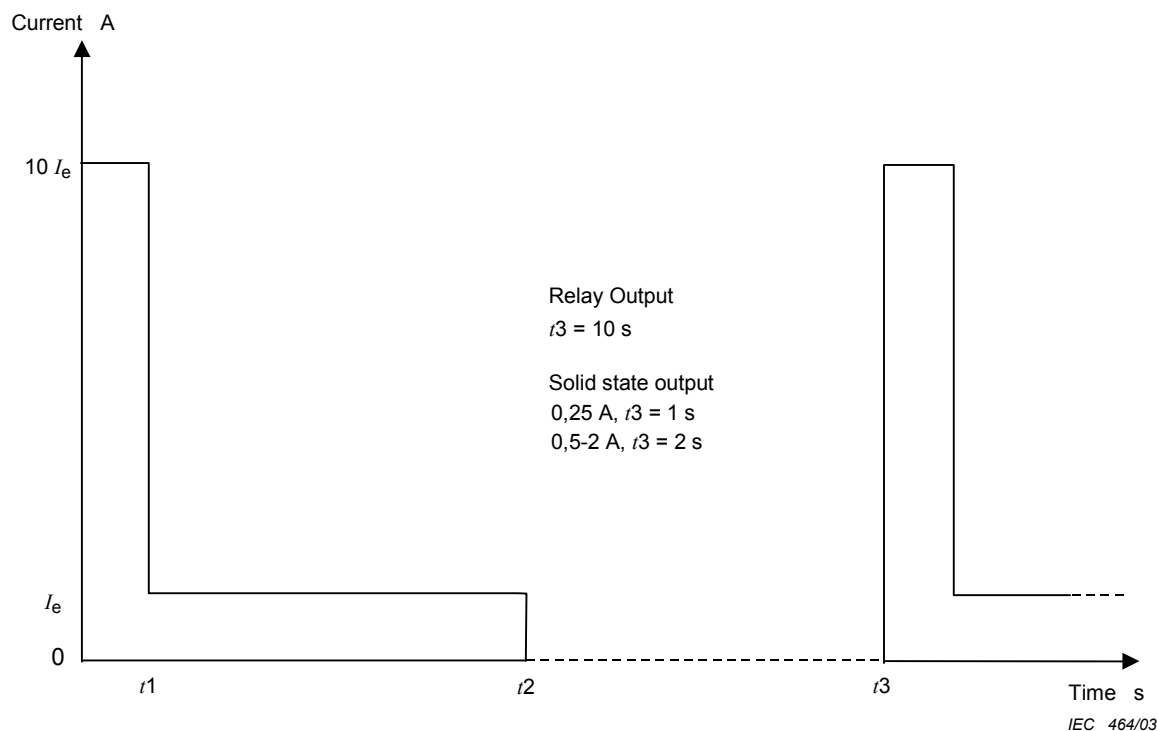

- t1: 2 cycles at F_n (F_n = rated line frequency)
t2: ON time
t3 - t2: OFF time (OFF time = ON time)
t3: Operation time

Figure 5 – Temporary overload waveform for digital a.c. outputs

5.2.2.2 Additional requirements

5.2.2.2.1 Output indicators

Each output channel shall be provided with a lamp or equivalent means to indicate the output state 1 condition when the indicator is energized.

5.2.2.2.2 Protected outputs

For outputs stated by the manufacturer to be protected

- the output shall either withstand and/or the associated protective device shall operate to protect the output for all steady-state values of output current greater than 1,1 times the rated value;
- after resetting or replacement of the protective device alone, as applicable, the PLC-system shall return to normal operation;
- optional restart capabilities may be selected among the 3 following types:
 - automated restart protected output: a protected output which automatically recovers after the overload is removed;
 - controlled restart protected output: a protected output which is reset through signals (for example, for remote control);
 - manual restart protected output: a protected output which implies a human action to recover (the protection may be fuses, electronic interlocks, etc.).

Requirements of this subclause are verified in accordance with 6.4.3.2.

NOTE 1 Operation under overload condition for an extended period of time may affect the operating life of the module.

NOTE 2 The protected outputs will not necessarily protect the external wiring. It is the user's responsibility to provide that protection when it is needed.

5.2.2.2.3 Short-circuit-proof outputs

For outputs stated by the manufacturer to be short-circuit-proof:

- for all output currents greater than $I_{e\ max}$ and up to 2 times the rated value I_e , the output shall operate and withstand temporary overload(s). Such temporary overload(s) shall be specified by the manufacturer.
- for all output currents prospectively above 20 times the rated value, the protective device shall operate. After resetting or replacement of the protective device alone, the PLC-system shall return to normal operation.
- for output currents in the range of 2 times to 20 times I_e , or for temporary overload(s) beyond the limits specified by the manufacturer (item 1 above), the module may require repair or replacement.

Requirements of this subclause are verified in accordance with 6.4.3.2.

5.2.2.2.4 Non-protected outputs

For outputs stated by the manufacturer to be non-protected, if the manufacturer recommends an external protection device, then the outputs shall meet all the requirements stated for the short-circuit-proof outputs.

5.2.2.2.5 Electromechanical relay outputs

Electromechanical relay outputs shall be capable of performing at least 0,3 million operations with the load specified for AC-15 utilization category (durability class 0.3) according to IEC 60947-5-1.

The type test is not required if the relay components have been shown to comply with the requirements of IEC 60947-5-1.

5.2.3 Digital outputs for direct current (current sourcing)

Requirements of this subclause are verified in accordance with 6.4.3.

5.2.3.1 Rated values and operating ranges (d.c.)

Digital outputs shall comply with the ratings given in the following Table 9, at the output voltage(s) stated by the manufacturer according to 5.1.1.1.

**Table 9 – Rated values and operating ranges (d.c.)
for current-sourcing digital d.c. outputs**

Rated current for state 1	I_e (A)	0,1	0,25	0,5	1	2	Normative items
Current range for state 1 at maximum voltage (continuous)	Max. (A)	0,12	0,3	0,6	1,2	2,4	
Voltage drop, U_d	U_d	–	–	–	–	–	–
Non-protected output	Max. (V)	3	3	3	3	3	–
Protected and short-circuit-proof		3	3	3	3	3	(1)
Leakage current for state 0	Max. (mA)	0,1	0,5	0,5	1	1	(2), (3)
Temporary overload	Max. (A)	See Figure 6 or as specified by manufacturer					

(1) For 1A and 2A rated currents, if reverse polarity protection is provided, a 5 V drop is allowed. This makes the output incompatible with a type 1 input of the same voltage rating.

(2) The resulting compatibility between d.c. outputs and d.c. inputs, without additional external load, is as follows:

Rated output current I_e (A):	0,1	0,25	0,5	1	2
Type 1:	yes	yes	yes	no	no
Type 2:	yes	yes	yes	yes	yes
Type 3:	yes	yes	yes	yes	yes

(3) With adequate external load, all d.c. outputs may become compatible with all Type 1, Type 2 and Type 3 d.c. inputs.

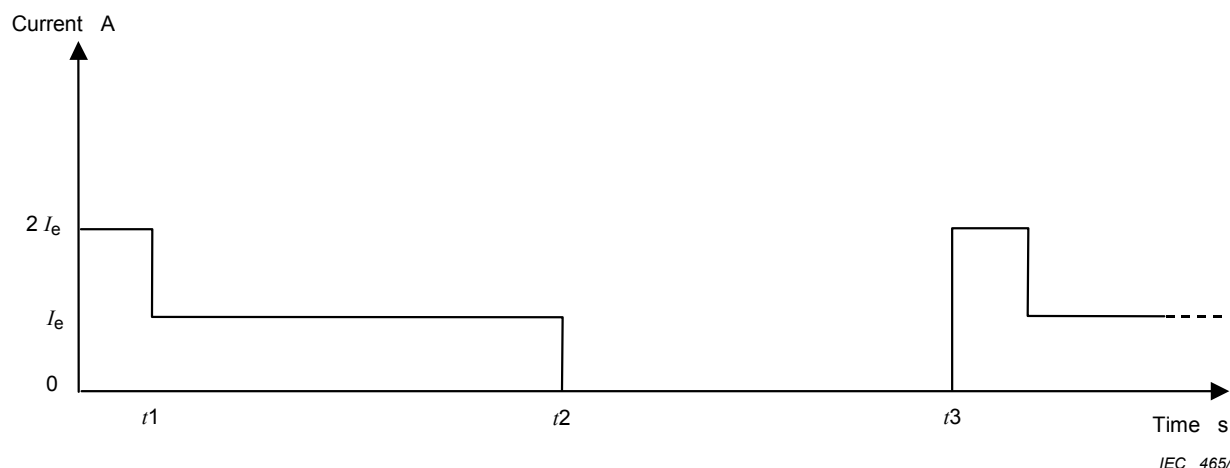

IEC 465/03

- t_1 = surge time = 10ms
 t_2 = ON time
 $t_3 - t_2$ = OFF time (OFF time=ON time)
 t_3 = operation time = 1s

Figure 6 – Temporary overload waveform for digital d.c. outputs

5.2.3.2 Additional requirements

Other requirements are the same as for current sourcing outputs for a.c. as defined in 5.2.2.2, except for

- protected outputs: the limit is $1,2 I_e$ instead of $1,1 I_e$.
- electromechanical relay outputs: AC-15 is replaced by DC-13.

5.3 Analogue I/Os

Requirements of this subclause are verified in accordance with verification of analogue I/Os test in 6.4.4.

5.3.1 Analogue inputs

Rated values of signal range and impedance for analogue inputs to PLC-systems shall be as specified in the following Table 10.

Table 10 – Rated values and impedance limits for analogue inputs

Signal range	Input impedance limits	Normative Items
±10 V	≥10 kΩ	–
0-10 V	≥10 kΩ	–
1-5 V	≥5 kΩ	–
4-20 mA	≤300 Ω	–
0-20 mA	≤300 Ω	(1)

(1) Not recommended for future designs.

Analogue inputs may be designed to be compatible with standard thermocouples or standard resistive temperature devices (RTDs) such as PT100 sensors. Thermocouple analogue inputs shall provide a method for cold-junction compensation.

5.3.2 Analogue outputs

Rated values of signals range and load impedance for analogue outputs of PLCs shall be as specified in Table 11.

Table 11 – Rated values and impedance limits for analogue outputs

Signal range	Load impedance limits	Normative items
±10 V	≥1 000 Ω	(1)
0-10 V	≥1 000 Ω	(1)
1-5 V	≥500 Ω	(1)
4-20 mA	≤600 Ω	(2)
0-20 mA	≤600 Ω	(2), (3)

(1) Voltage analogue outputs shall withstand any overload down to short circuit.
 (2) Current analogue outputs shall withstand any overload up to open circuit.
 (3) Not recommended for future designs.

5.4 Communication interface requirements

The configuration tested according to Clause 2 of this Part of IEC 61131 shall be equipped with communication interface modules where applicable and with communication links specified by the manufacturer.

Requirements of this subclause are verified in accordance with 6.5.

5.5 Main processing unit(s) and memory(ies) of the PLC-system requirements

This subclause should be read in conjunction with IEC 61131-1 and with 5.6 and 5.7 of this part (respectively, RIOSs and peripherals).

See Figure 2 and Annex A for the definition and illustration of the PLC-system, the main processing unit (MPU), the main memory and other terms used in this subclause.

Main processing unit(s) and memory(ies) are part of the permanent PLC installation and therefore tested accordingly.

Requirements of this subclause are verified in accordance with 6.6.

5.6 Remote input/output stations (RIOSs) requirements

RIOSs are part of the permanent PLC installation and therefore to be tested accordingly. However, for ease of testing, isolated RIOSs may be tested separately where appropriate.

Requirements for voltage drops and interruption of the power supply(ies) fully apply to RIOSs. These requirements are shown in 8.3.4.

In case of loss of communication with the MPU application programme, RIOSs shall be able to fix the states of their outputs to specified values, within specified delays and without passing through unspecified states and be capable of providing a fault indication signal.

The MPU system shall provide the user's application programme with relevant information on the current status of RIOSs.

Requirements of this subclause are verified in accordance with 6.7.

5.7 Peripherals (PADTs, TEs, HMIs) requirements

Peripherals which are not a permanent part of the PLC-system shall cause no malfunction of the system when making or breaking communication with an operating system.

Requirements are verified in accordance with 6.2.5.

Connectors for the peripherals shall be polarized to prevent improper connection, or the PLC-system shall be so designed that no malfunction occurs if a connection is improper.

The system consisting of the peripheral and the PLC-system shall be designed to ensure that the edited programme executing in the PLC-system is functionally identical to the edited programme displayed on the peripheral.

If on-line modification of the application programme and/or the modes of operation of the PLC-system by a peripheral is possible (i.e. when the PLC-system is in active control of a machine or industrial process), then

- the peripheral shall automatically give clear warnings equivalent to “during on-line modification, programme display may differ from application programme, control of the machine/ process may be interrupted during ... ms, etc.”, as applicable.

- the peripheral shall ask the operator “Do you really want to carry out this action?” or some similar words and execute the command only after a positive reply has been given by the operator.

It shall be possible to upload the new application programme to the manufacturer's supplied data media and verify, on line, that the record is functionally equivalent to it, and means shall be provided to prevent unauthorized use of these functions (hardware or software).

Requirements of this subclause are verified in accordance with 6.8.

5.8 PLC-system self-tests and diagnostics requirements

The manufacturer shall provide means for self-tests and diagnostics of the PLC-system operation. Such means shall be built-in services of the PLC-system and/or recommended ways to implement the intended application.

The following shall be provided:

- a means for monitoring the user's application programme (i.e. watchdog timer, etc.),
- a hardware or software means to check the memory integrity,
- a means to check the validity of the data exchanged between memory(ies), processing unit(s) and I/O modules (such as an application loop-back test),
- a means to check that the power supply unit(s) do(es) not exceed the current and voltage limits allowed by the hardware design,
- a means to monitor the status of MPU.

The permanently installed PLC-system shall be capable of operating an alarm signal on an alarm output. When the system is monitored as “functioning correctly”, this alarm output shall be in a predetermined state; in the other case it shall go to the opposite state. The manufacturer shall specify the conditions of the “correct functioning state” and the self-tests which are executed to drive this alarm output.

RIOSs shall be capable of operating an alarm signal on an alarm output (for example, through a digital output module) in the event of loss of power or loss of normal communication with the MPU and go to a predetermined state (see 5.6).

Requirements of this subclause are verified in accordance with 6.9.

5.9 Functional earthing

There are no constructional requirements such as interference immunity control, RFI protection, etc., for functional earthing terminals (except for marking requirements as given in 5.11.3).

5.10 Mounting requirements

Provisions shall be made for securely mounting equipment to a supporting surface.

Alternate mounting methods, such as DIN rails, should also provide for secure mounting of the equipment.

A bolt, screw, or other part used to mount a component of the equipment shall not be used for securing the equipment to a supporting surface, DIN rail, etc.

5.11 General marking requirements

For all equipment, as a minimum, the information marked on the device shall identify the manufacturer (the company bringing the product to market) and the device. The remaining information shall be provided in the data sheet. See Clause 7.

The following information shall be provided by the manufacturer:

- manufacturer's name, trade mark or other identification,
- model/catalogue number, type designation or name,
- software serial number and/or revision level (see 1.2), where applicable,
- hardware serial number or series and/or revision level (see 1.2), and date code or equivalent.

Requirements of this subclause are verified in accordance with 6.10.

5.11.1 Functional identifications

The function of each I/O module shall be unambiguously identifiable when it is placed in its service position and operating, by means of a convenient manufacturer's mark.

All operator's switches, indicator lamps, and connectors shall be identified or have provisions for identification.

5.11.2 Module location and module identifications

Space shall be provided for identification of each module and I/O channel on or near to the modules.

5.11.3 Functional earth terminals markings

Functional earth terminals (i.e. used for non-safety purposes such as interference immunity improvement) shall be marked with the following symbol:



NOTE For proper dimensioning, see IEC 60417-5018.

5.12 Requirements for normal service and functional type tests and verifications

Test and verifications for normal service and function shall be performed by the manufacturer, in accordance with Clause 6.

5.13 Requirements for information on normal service and function

Information on normal service and function shall be provided by the manufacturer, in accordance with the requirements of Clause 7.

6 Normal service and functional type tests and verifications

6.1 Climatic tests

Tests are performed on unpackaged equipment.

Temperature-sensitive components that are normally serviced and removed by the user may be removed, if so requested by the manufacturer.

6.1.1 Dry-heat and cold withstand tests

Table 12 – Dry-heat and cold withstand tests

	Dry heat	Cold
Reference test	IEC 60068-2-2, test Bb	IEC 60068-2-1, test Ab
Preconditioning	According to manufacturer's specifications	
Initial measurement	According to PFVP (2.5)	
Conditioning	Power supply unconnected	
Temperature	+70 °C ± 2 °C	-40 °C ± 3 °C (2)
Duration of exposure	16 h ± 1 h	16 h ± 1 h
Measuring and/or loading during conditioning	None	
Recovery procedure	IEC 60068-2-2, test Bb	IEC 60068-2-1, test Ab
Time	1 h minimum	
Climatic conditions	See 6.1 and 2.6(1)	
Special caution		No condensation (1)
Power supply	Power supply unconnected	
Final measurements	According to PFVP (2.5)	
(1) All external and internal condensation shall be removed by airflow, prior to connecting again the basic PLC-system to a power supply.		
(2) -25 °C ± 3 °C is acceptable, but not recommended for future designs		

6.1.2 Variation of temperature

Table 13 – Change of temperature, withstand and immunity tests

	Withstand test	Immunity test
Reference test	IEC 60068-2-14, test Na	IEC 60068-2-14, test Nb
Preconditioning	According to manufacturer's specification	
Initial measurements	According to PFVP (see 2.5)	
Conditioning	Power supply unconnected	Power supply connected
Measurement and/or loading during conditioning	None	(3)
Low temperature	-40 °C ± 3 °C (5)	+5 °C ± 2 °C
High temperature		
Open equipment	+70 °C ± 2 °C	+55 °C ± 2 °C
Enclosed equipment	+70 °C ± 2 °C	+40 °C ± 2 °C
Exposure time at each temperature	3 h ± 30 min	3 h ± 30 min
Transport time	Less than 3 min	Not applicable
Temperature variation speed	Not applicable	3 °C/min. ± 0,6 °C/min.
Number of cycles	2	5
Recovery procedure time	IEC 60068-2-14, test Na Less than 2 h	Not applicable Not applicable
Climatic conditions	See 6.1 and 2.6(4)	Not applicable
Power supply	Power supply unconnected	Not applicable
Final measurements	(1)	(2)
(1) PFVP according to 2.5 performed after recovery.		
(2) PFVP according to 2.5 performed during test.		
(3) Multi-channel output modules shall be derated as specified by the manufacturer.		
(4) All external and internal condensation shall be removed by airflow, prior to connecting again the basic PLC-system to a power supply.		
(5) -25 °C ± 3 °C is acceptable but not recommended for future designs.		

6.1.3 Cyclic damp heat withstand test

Table 14 – Cyclic (12 + 12) damp-heat test

Reference test	IEC 60068-2-30, test Db
Preconditioning	According to manufacturer's specifications
Initial measurements	According to PFVP (2.5)
Conditioning	None
Measurement and/or loading during conditioning	None
Details of mounting/support	None
Variant	2
Special precautions	Power supply disconnected
Temperature	+55 °C
Number of cycles	2
Recovery procedure time	- Under controlled conditions prescribed in IEC 60068-2-30 (1)
Climatic conditions	Power supply disconnected (1)
Power supply	
Final measurements	PFVP according to (2.5) performed after recovery
(1) All external and internal condensation shall be removed by airflow, prior to reconnecting the basic PLC-system to a power supply.	

6.2 Mechanical tests

6.2.1 Vibration (type test associated with normal service conditions)

Table 15 – Immunity vibration test

Reference test	IEC 60068-2-6, test Fc
Preconditioning	According to manufacturer's specifications
Initial measurements	According to PFVP (2.5)
Details of mounting/support	According to manufacturer's specifications for portable and hand-held equipment
Motion	Sinusoidal
Vibration amplitude/acceleration	–
5 Hz ≤ f < 9 Hz	3,5 mm amplitude
9 Hz ≤ f ≤ 150 Hz	1,0 g
Vibration type	Sweeping, at a rate of 1 octave/min (± 10 %)
Vibration duration	10 sweep cycles per axis on each of 3 mutually perpendicular axes
–	–
Measurement and verification during loading	According to PFVP (2.5)
Verification after tests	According to PFVP (2.5)

6.2.2 Shock (type test associated with normal service conditions)

Table 16 – Immunity shock test

Reference test	IEC 60068-2-27, test Ea
Preconditioning	According to manufacturer's specifications
Initial measurements	According to PFVP (2.5)
Details of mounting/support	According to manufacturer's specifications for portable and hand-held equipment
Type of shock	Half-sine
Shock severity	15 g peak, 11 ms duration
Application	Three shocks in each direction per axis, on 3 mutually perpendicular axes (total of 18 shocks)
Measurement and verification during loading	According to PFVP (2.5)
Verification after tests	According to PFVP (2.5)

6.2.3 Free fall (type test associated with normal service conditions)

Table 17 – Free-fall immunity/withstand tests (portable and hand-held equipment)

Reference tests: Random and flat drops Supported drops	IEC 60068-2-32, procedure 1 IEC 60068-2-31, 3.2.1
Preconditioning	According to manufacturer's specifications
Initial measurements	According to PFVP (2.5)
Details of mounting/support	EUT equipped with manufacturer's standard cable(s) (if any)
Measurement and verification during loading	According to PFVP (2.5)
Verification after the tests	According to PFVP (2.5)

6.2.4 Free fall (type test associated with transport and storage conditions)

Table 18 – Free-fall withstand test (units within manufacturer's original packaging)

Reference test	IEC 60068-2-32, procedure 1
Selection of samples	Each type of manufacturer's original packaging with the heaviest unit using it
Initial measurements	According to PFVP (2.5)
Details of mounting/support	EUT equipped with manufacturer's standard cable(s) (if any)
Measurement and verification during loading	None
Verification after the test	According to PFVP (2.5)

6.2.5 Plugging/unplugging of removable units

Table 19 – Insertion/withdrawal of removable units

Description of the test for permanently installed units	50 insertions/withdrawals are performed without power; then the equipment shall pass the PFVP (2.5)
Description of the test for non-permanently installed units	500 insertions/withdrawals are performed while the basic PLC-system is performing functional test programmes as required for PFVP (2.5) Insertions and withdrawals shall not affect the proper operation of the basic PLC-system Communication on the physical link during the test is not required

6.3 Verification of special functional requirements for power ports and memory back-up – Special immunity limits for power ports

Perform the proper functional verification procedure of 2.5 during tests under 6.3.1 and 6.3.2.

Power ports are mains power input port (port F, Figure 2).

6.3.1 Verification of functional mains power input port (a.c. or d.c.)

6.3.1.1 Voltage range, voltage ripple and frequency range test

Table 20 – Voltage ripple and frequency range immunity test (1)

Reference test	None	
EUT configuration	According to manufacture's specifications	
Initial measurements	According to PFVP (2.5)	
Description of tests (1)	Gradual shut-down (See Figure 7)	Fast variations (See Figure 8)
–		
AC voltage ($k \times U_e$) (2)	$k = 0,85$	$k = 1,10$
AC frequency ($k \times F_n$) (2)	$k = 0,94$	$k = 1,04$
DC voltage ($k \times U_e$) (2)	$k = 0,85$	$k = 1,20$
Ripple continuous ($k \times U_e$) (2)	$k = 0,05$	$k = 0,05$
Test duration	30 min	30 min
Measurement and verification during loading	According to PFVP (2.5)	
Verification after tests	According to PFVP (2.5)	
Performance criteria	A	
(1) If there are separate mains supplies to the PLC-system the tests may be carried out on each supply separately.		
(2) See precise definitions in Table 6.		

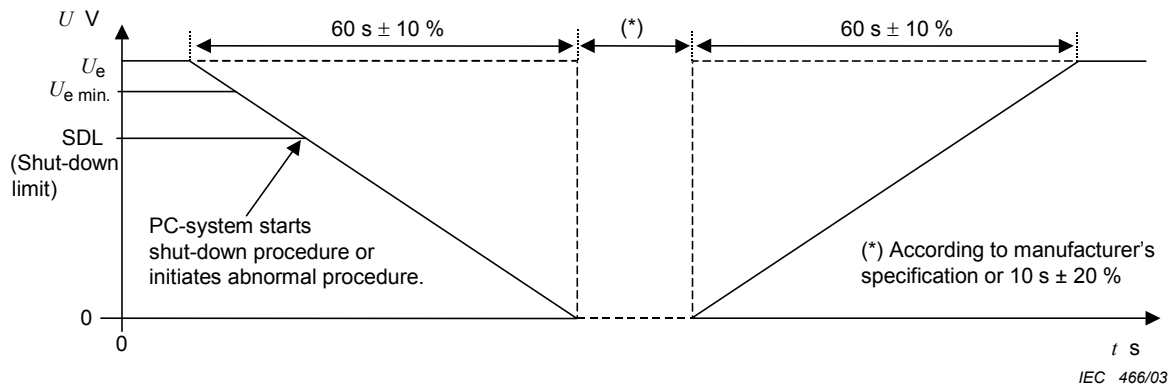

Figure 7 – Gradual shut-down/start-up test

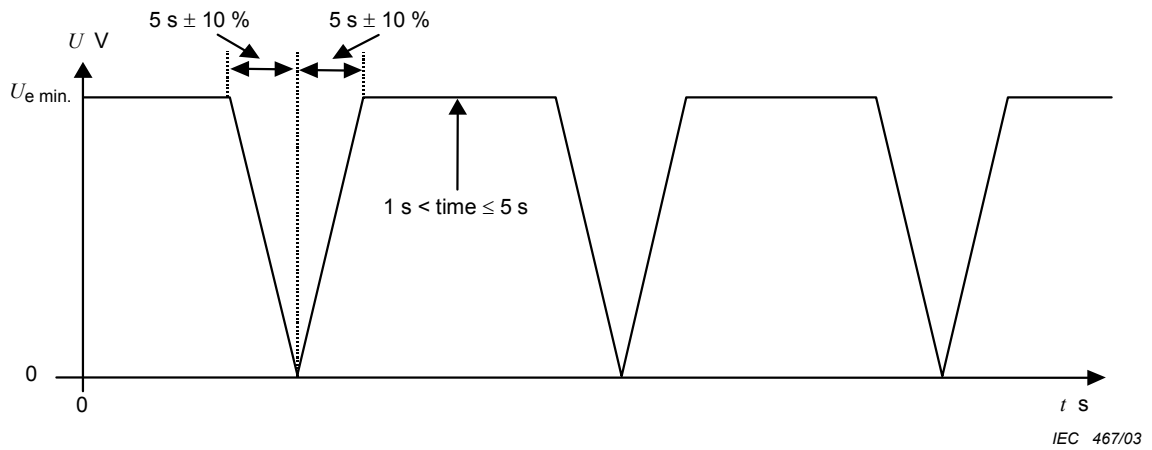

Figure 8 – Fast supply voltage variation test

6.3.1.2 Third harmonic immunity test

Table 21 – Third harmonic immunity test

Reference test	None
EUT configuration	According to manufacture's specifications
Initial measurements	According to PFVP (2.5)
Description of tests (1)	A third harmonic voltage (150 Hz or 180 Hz) adjusted to 10 % of the mains rated voltage is added to the a.c. mains power supply with 0° and 180° (See Figure 9)
-	5 min
Test duration for each phase	According to PFVP (2.5)
Measurement and verification during loading	According to PFVP (2.5)
Verification after tests	

(1) If there are separate mains supplies to the PLC-system, the test may be carried out on each supply separately.

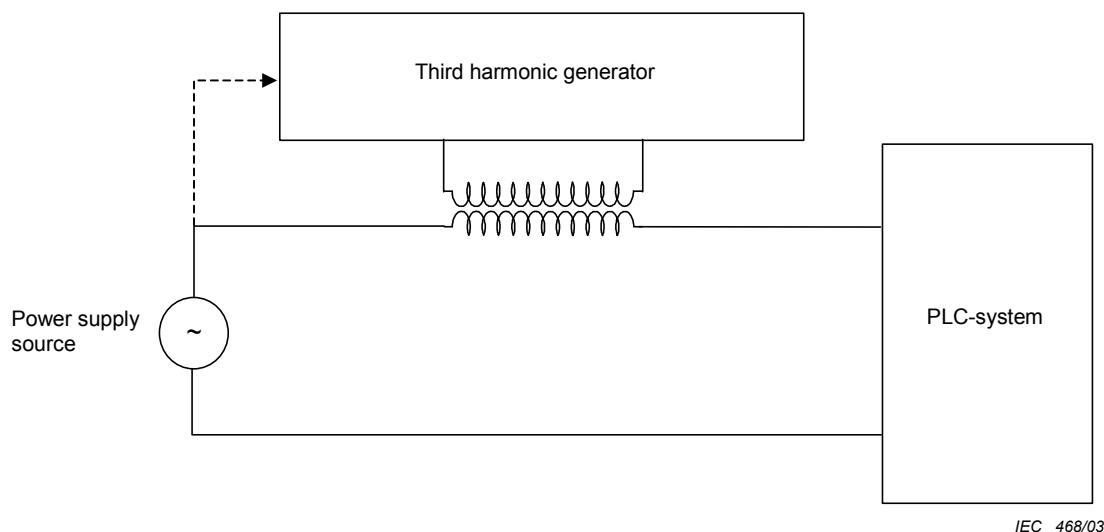

Figure 9 – Third harmonic immunity test

6.3.1.3 Shut-down test (sudden supply interruption)

Test description: during shut-down due to the supply interruption, the system behaviour shall be observed. The test is repeated twice.

Performance criteria:

The requirement given above shall be met. In addition, from the start of interruption to shut-down, there shall be no change not caused by the normal test programme and no erratic or unintended condition of any kind.

6.3.1.4 Start-up test

When the external supply is applied for a time specified by the manufacturer, the PLC-system shall start again according to the specifications of the manufacturer (automatic or manual restart, initialization sequence, etc.). During the start-up, there shall be no erratic or unintended condition.

6.3.2 External energy supply variation tests (immunity tests)

At voltages below the minimum normal service conditions limits and/or frequencies beyond the normal service condition limits, the PLC-system shall “either maintain normal operation or go to a predefined state and have a clearly specified behaviour until normal operation is resumed”.

Performance criteria: during the tests, the PFVP (2.5) shall ensure that the behaviour of the basic PLC-system is as specified by the manufacturer and that there is no change not caused by the PFVP test programme and no erratic or unintended conditions of any kind.

6.3.2.1 Gradual shut-down/start-up test

Table 22 – Gradual shut-down/start-up test

Reference test	None
EUT configuration – – –	The behaviour of the basic PLC-system shall be according to PFVP (2.5) at minimum operational voltage and frequency (gradual shut-down of 6.3.1.1) and at maximum operational voltage and frequency (fast variations of 6.3.1.1)
Test description Initial/final conditions Lowest voltage (V) Waiting time at lowest voltage (s) Number of trials Time interval between trials	See Figure 7 Power supply at rated values (U_e, F_n) 0 (zero) 10 s \pm 20 % 3 1 s < time interval \leq 10 s
Measurement and verification during loading Voltage shut-down limit (SDL) – –	According to PFVP (2.5) The voltage at which the basic PLC-system starts the manufacturer's specified shut-down sequence or initiates a behaviour not in accordance with the PFVP during the decreasing voltage sequence
Average SDL (SDL_{av}) Performance criteria	The average of 3 measured SDL According to 6.3.2

6.3.2.2 Supply voltage variation tests

Table 23 – Supply voltage variation tests

Reference test	None	
EUT configuration – – –	The behaviour of the basic PLC-system shall be according to PFVP (2.5) at minimum operational voltage and frequency (gradual shut-down of 6.3.1.1) and at maximum operational voltage and frequency (fast variations of 5.3.1.1)	
Description of tests –	Fast variations (See Figure 8)	Slow variations (See Figure 10)
Initial/final conditions	Power supply at rated values ($U_{e\ min}, F_n$)	
Lowest voltage (U)	0 (zero)	0,9 $SDL_{av} \pm 10\%$ (1)
Waiting time at lowest voltage (s)	0 (zero)	0 (zero)
Number of trials	3	3
Time interval between trials	1 s < time interval \leq 5 s	
Measurement and verification during loading Pass/fail criteria	According to PFVP (2.5) According to 6.3.2	
(1) SDL_{av} is a result of the gradual shut-down test (see 6.3.2.1).		

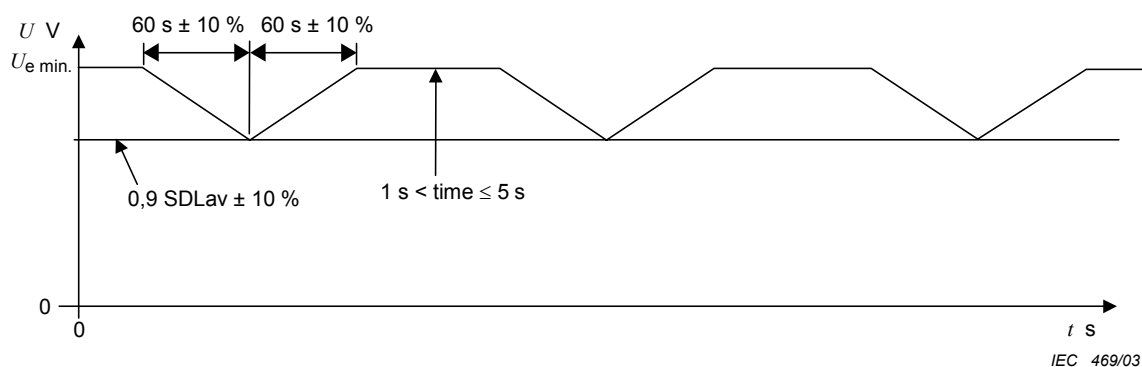

Figure 10 – Slow supply voltage variation test

6.3.3 Improper power supply connection tests

6.3.3.1 Reversal of d.c. power supply polarity test (withstand test)

The rated voltage of reverse polarity shall be applied for 10 s. The results shall comply with the conditions stated by the manufacturer (such as fuse-blowing).

After the test, the basic PLC-system shall pass the proper verification procedure (see 2.5). Protective devices such as fuses may be reset prior to verification.

6.3.3.2 Improper voltage level and/or frequency test

For voltage level above the maximum normal service conditions limit $U_{e \max}$ or/and frequencies beyond the normal service conditions limits $F_{n \max}$ and $F_{n \min}$, the test shall be agreed between the user and the manufacturer.

6.3.4 Verification of memory back-up requirements

6.3.4.1 Back-up duration withstand test

Table 24 – Back-up duration withstand test

Reference test	None	
EUT configuration	According to PFVP (2.5)	
Duration of preparation Tests to be performed –	According to manufacturer's specifications (energy source may require time to be fully charged) Either Test A or Test B defined below	
Description of tests	Test A	Test B
Initial conditions	Energy source fully charged; external energy supply disconnected	
Temperature –	Open equipment 55 °C Enclosed equipment 40 °C	General conditions (2.6)
Duration	300 h	1 000 h
Verification after the test –	According to PFVP (2.5). The PLC-system shall be fully operational. No loss of retentive data is allowed	

6.3.4.2 Verification of manufacturer's method of changing the energy source

Table 25 – Change of energy source test

Reference test	None
EUT configuration Replacement of energy source –	According to PFVP (2.5) According to manufacturer's specifications (energy source may require time to be fully charged)
Verification after the tests –	According to PFVP (2.5) The PLC-system shall be fully operational. No loss of retentive information is allowed

6.3.4.3 Verification of other requirements

Check the required warning of “low battery voltage” (see requirements in 5.1.2). (Remove the energy source and apply the proper controlled voltage in place of the energy source.)

6.4 Verification of input/output requirements

6.4.1 General

Test procedures are not defined in detail hereinafter. Detailed procedures shall be agreed upon by the user and the manufacturer and shall be such that the conditions defined in 1.2 shall not be impaired.

Though test procedures are not defined in detail, all tests which are referenced shall be performed.

Unless otherwise specified in this subclause, all tests shall be carried out twice on the same I/O channel(s):

- First test: at minimum service temperature (T_{min}), i.e. 5 °C or T_{min} given in Table 2.
- S test: at maximum service temperature (T_{max}), i.e. 40 °C/55 °C or T_{max} given in Table 2.

It is not required to test more than 1 analogue input channel and 1 digital input channel of each type, but all different types which are represented in the basic PLC-system shall be tested.

All channels of multi-channel output modules shall be tested.

6.4.2 Verification of digital inputs

6.4.2.1 Operating range test

Verify that all requirements are met.

Test procedures: To be agreed upon by the user and manufacturer.

6.4.2.2 Reversal of signal polarity test (withstand test)

Test procedure: A signal of reverse polarity for digital inputs shall be applied for 10 s.

Verification:

The results shall be as stated by the manufacturer. The device shall pass the PFVP (see 2.5). Protective devices such as fuses may be reset prior to verification.

6.4.2.3 Verification of other requirements

Verify that the general requirements for digital I/Os under 5.2 and the requirement of 5.2.1.3 are met.

6.4.3 Verification of digital outputs

6.4.3.1 Operating range test

Verify that all requirements are met.

Test procedures:

Current range: To be agreed upon by the user and manufacturer.

Voltage drop: To be agreed upon by the user and manufacturer.

Leakage current: Devices/circuits intended for output protection shall not be removed.

Temporary overload: According to IEC 60947-5-1, (AC-15 or DC-13, as applicable). For short-circuit proof outputs, the current values shall be respectively $2 I_e$ to $20 I_e$ (as given in 5.2.2.2.3).

6.4.3.2 Test of protected, not-protected, and short-circuit proof outputs

Table 26 – Overload and short-circuit tests for digital outputs

Reference test	None				
EUT configuration	According to manufacturer's specifications				
Details of mounting/support	According to manufacturer's specifications				
Loading	It is sufficient to check one I/O channel of each type under test				
Initial measurements	According to PFVP (2.5)				
Description of the tests	A	B	C	D	E
Prospective currents ($k \times I_e$)	1,2/1,3 (1)	1,5	2	5	21
Duration of test (min)	5	5	5	5	5
Order of trials	–	–	–	–	–
First series (at T_{min})	1	2	3	4	5
Second series (at T_{max})	6	7	8	9	10
Time intervals between tests	10 min \leq time intervals \leq 60 min				
Application of the test protected outputs	Yes	Yes	Yes	Yes	Yes
Short-circuit proof outputs	No	No	Yes (2)	No	Yes (4)
Not-protected outputs (3)	No	No	Yes (2)	No	Yes (4)
Measurement and verification	See requirements in 5.2.2.2 and 5.2.3.2				
during the overload	According to PFVP (2.5)				
immediately after overload	According to PFVP (2.5)				
after overload and proper resetting	According to PFVP (2.5)				
(1) 1,2 for a.c. outputs, 1,3 for d.c. outputs.					
(2) For currents in the range of 2 times to 20 times I_e , the module may require repair or replacement.					
(3) Protective device(s) to be provided or specified by the manufacturer shall be installed.					
(4) Protective device(s) shall operate. They shall be reset or replaced as applicable for the following test.					

6.4.3.3 Reversal of signal polarity test (withstand test)

If the equipment is designed to prevent reversal of signal polarity, the withstand test may be not carried out and replaced by proper visual inspection.

Test procedure:

A signal of reverse polarity for digital d.c. outputs shall be applied for 10 s.

Verification:

The results shall be as stated by the manufacturer.

The device shall pass the PFVP (see 2.5). Protection devices such as fuses may be reset prior to verification.

6.4.3.4 Verification of other requirements

Verify that general requirements for digital I/Os under 5.2.2 or 5.2.3 and the remaining requirements of 5.2.2.2 or 5.2.3.2 are met (output indicators and electromechanical relay outputs).

6.4.4 Verification of analogue I/Os

6.4.4.1 Operating range tests

Verify that all requirements are met.

Test procedures: To be agreed upon by the user and manufacturer.

6.4.4.2 Analogue input overload withstand test

Test procedure:

To be agreed upon by the user and manufacturer.

Measurement and verification:

During loading:

During the application of specified maximal overload, no physical damage or abnormal phenomenon shall be detected.

After the test:

The accuracy shall be verified for the minimal and the maximal value of the input range according to PFVP (see 2.5).

6.4.4.3 Short-circuit test (voltage output) and open-circuit test (current output)

When the short circuit (for a voltage output) or the open circuit (for a current output) is realized, no physical damage or abnormal phenomenon shall be detected. After the test, perform the proper functional verification procedure of 2.5.

6.4.4.4 Voltage supply variation test

This test shall be performed when the analogue I/O modules are externally energized by an independent power supply (i.e. independent from the other I/O modules power supply(ies) of the PLC-system).

The power supply is replaced by a variable power source. The voltage is adjusted to the extreme values of the specified range of voltage supply. The module shall then pass the PFVP and the output variations shall be inside the specified range (see 2.5).

6.4.4.5 Reversal of signal polarity test (withstand test)

If the equipment is designed to prevent confusion of signal polarity, the withstand test may not be carried out and replaced by proper visual inspection.

Test procedure:

A signal of reverse polarity for unipolar analogue inputs shall be applied for 10 s.

Verification:

The results shall be as stated by the manufacturer. The device shall pass the PFVP (see 2.5). Protection devices such as fuses may be reset prior to verification.

6.4.4.6 Verification of other requirements

Type tests are not required; all requirements non-tested shall be verifiable under a procedure to be agreed upon by the manufacturer and the user.

6.5 Verification of communication interface requirements

Type tests are not required; all requirements non-tested shall be verifiable under a procedure to be agreed upon by the manufacturer and the user.

6.6 Verification of MPU requirements

Type tests are not required; all requirements non-tested shall be verifiable under a procedure to be agreed upon by the manufacturer and the user.

6.7 Verification of remote I/O stations

6.7.1 Response time test

This test verifies the effect on transfer time(s) introduced to provide remote input information and RIOSs status to the application programme and to transmit its logical decisions to remote outputs.

Procedure:

An application test programme consisting of copying input status to outputs is run in 4 similar configurations:

- local inputs to local outputs,
- remote inputs to local outputs,
- local inputs to remote outputs and
- remote inputs to remote outputs.

Pass/fail criteria:

The total system response times and the subsequent variations of transfer time(s) shall conform to the manufacturer's published specifications.

6.7.2 Loss of communication test

When communication is removed, outputs shall assume a manufacturer's specified state within a manufacturer's specified interval without erratic or unintended behaviour, and the communication error shall be signalled to the user.

Procedure:

The test is performed by disconnecting a) the link, b) the RIOS external power supply, and observing the behaviour of the basic PLC-system (i.e. of the MPU as well as of the RIOS and of their outputs).

Pass/fail criteria:

According to requirements.

6.7.3 Verification of other requirements

Type tests are not required; all requirements non-tested shall be verifiable under a procedure to be agreed upon by the manufacturer and the user.

6.8 Verification of peripheral (PADTs, TEs, HMIs) requirements

All requirements non-tested shall be verifiable under a procedure to be agreed upon by the manufacturer and the user.

6.9 Verification of PLC-system self-tests and diagnostics

All requirements non-tested shall be verifiable under a procedure to be agreed upon by the manufacturer and the user.

6.10 Verification of markings and manufacturer's documentation

Verify the requirements of 5.11 by visual inspection.

7 General information to be provided by the manufacturer

The manufacturer shall provide users with information required for the application, design, installation, commission, operation and maintenance of the PLC-system. In addition, the manufacturer may provide user training.

Information to be made available can be in other than printed form.

7.1 Information on type and content of documentation

Three types of documentation are defined:

- catalogues and datasheets,
- user's manuals and
- technical documentation.

NOTE For the preparation of the instructions, see IEC 62079 and IEC 61506.

7.1.1 Information on catalogues and datasheets

These documents shall contain the description and the specifications of the PLC-system and its associated peripherals. Additionally, they shall contain any other relevant information to aid in understanding the application and use of these products including functional characteristics, equipment configuration rules, normal service conditions, physical dimensions and weights, and list compliance with standards and certifications.

7.1.2 Information on user's manuals

These documents shall include the necessary information for the proper installation, wiring, troubleshooting, user programming and commissioning of the PLC-system by the user. They shall include as a minimum

- installation and commissioning instructions,
- programming and troubleshooting instructions,
- maintenance and service requirements, and
- accessory and spare parts lists (for example, fuses).

7.1.3 Information on technical documentation

The manufacturer optionally may provide a set of documents which contain more information than those given in the user's manual such as: schematic diagrams, internal or external data protocols, bus assignments, physical dimension characteristics, energy available, firmware, internal test programmes or repair procedures, etc.

7.2 Information on compliance with this standard

The manufacturer shall provide information on compliance with this Part of IEC 61131, which can be claimed on two levels:

- a) full compliance with all of the requirements contained in all clauses of this part, such as indicated by reference to IEC 61131-2 without qualification;
- b) compliance with a portion of this Part of IEC 61131 where documentation identifies the specific clauses of this part with which the product has been determined to comply.

See 1.2 for details.

7.3 Information on reliability

If the manufacturer provides values of the mean time between failures (MTBF) of any subassembly or module, and of the type-test configuration(s) (PLC-system(s)) under normal service conditions the manufacturer shall also explain the method used to determine it.

7.4 Information on other conditions

The user should reach agreement with the manufacturer for any mechanical conditions that are not specified in this standard.

7.5 Information on shipping and storage

The manufacturer shall provide shipping and storing instructions.

7.6 Information on a.c. and d.c. power supply

The manufacturer shall provide the following information:

- data to allow selection of a suitable power distribution network to provide specified voltage at each power utilization point. This information includes peak inrush (at cold start and warm restart), repetitive peak and steady-state r.m.s. input currents under full-load conditions;
- external terminal identification for power supply interfaces;
- typical example(s) for power supply system(s);
- special supply installation requirements, if any, for PLC-systems energized through multiple power supplies or supply voltages and frequencies not included in 5.1.1.1;

- the effect of the following incorrect connections of power to the supply(ies):
 - reverse polarity,
 - improper voltage level and/or frequency and
 - improper lead connection;
- complete information on PLC-system behaviour for typical power up/down sequences.
- data to allow evaluation of the maximum values of interruption time which do not affect the normal operation of any PLC-system configuration; PS class (PS-1 or PS-2) of d.c. supplied devices;
- memory back-up time with respect to temperature and maintenance requirements;
- recommended time interval between replacement of energy sources, if applicable, and recommended procedure and subsequent effects on the PLC-system;
- peak inrush current (at cold start and warm restart) or recommended fuse size and blowing characteristics.

7.7 Information on digital inputs (current sinking)

The manufacturer shall provide the following information:

- volt-ampere curve over the full operating range, with tolerances or equivalent;
- digital input delay time for 0 to 1 and 1 to 0 transitions;
- existence of common points between channels;
- effect of incorrect input terminal connection;
- isolation potentials between channel and other circuits (including ground) and between channels under normal operation;
- type of input (Type 1, Type 2 or Type 3);
- monitoring point and binary state of visual indicator;
- effects when withdrawing/inserting input module under power;
- additional external load when interconnecting inputs and outputs, if needed;
- explanation of signal evaluation (for example, static/dynamic evaluation, interrupt release, etc.);
- recommended cable and cord lengths depending on cable type and electromagnetic compatibility;
- terminal arrangements;
- typical example(s) of external connections.

7.8 Information on digital outputs for alternating currents (current sourcing)

The manufacturer shall provide the following information with respect to digital outputs for a.c. operation:

- type of protection (i.e. protected, short-circuit-proof, non-protected output), and
- for protected outputs: operating characteristics beyond $1,1 I_e$ including the current(s) level(s) at which the protecting device energizes, the current behaviour beyond, and the time(s) involved;
- for short-circuit-proof outputs: information for replacement or resetting the protective device as required;
- for non-protected outputs: specification for protective device to be provided by the user, as required;
- output delay time for state 0 to state 1 and state 1 to state 0 transitions;
- commutation characteristics and turn-on voltage with respect to zero-voltage crossing;
- existence of common points between channels;
- terminal arrangements;
- typical example(s) of external connections;

- number and type of outputs (for example, NO/NC contacts, solid state, individually isolated channels, etc.);
- for electromechanical relays, the rated current and voltage complying with 5.2.2.2.5;
- output ratings for the other loads such as incandescent lamps;
- total output current for multi-channel modules (see 3.38);
- characteristics of suppresser networks incorporated into the output circuit against voltage peaks due to inductive kickback;
- type of external protective networks, if required;
- effects of incorrect output terminal connection;
- isolation potentials between channel and other circuits (including ground) and between channels under normal operation;
- monitoring points of visual indicators in the channel (for example, MPU side/load side);
- recommended procedures for changing output modules;
- output behaviour during interruptions of MPU control, voltage drops and interruptions and power up/down sequences (see also 5.6);
- way of operation (i.e. latching/non-latching type);
- effects of multiple overloads on isolated multi-channel modules.

7.9 Information on digital outputs for direct current (current sourcing)

Information to be provided by the manufacturer for digital outputs for d.c. shall be the same as for digital outputs for a.c., as defined in 7.8. However, the specification of commutation for zero-voltage crossing does not apply, and with regard to electromechanical relay outputs, AC-15 is replaced by DC-13 in 5.2.2.2.5.

7.10 Information on analogue inputs

Besides the type and standard range, the manufacturer shall provide the following information.

7.10.1 Information on analogue input static characteristics

Static characteristics	Units and examples
1) Input impedance in signal range (manufacturer should specify if this is in the on or off state)	Ω
2) Analogue input error:	–
• maximum error at 25 °C	–
• temperature coefficient	\pm % of full scale (which scale)
3) Maximum error over full temperature range	\pm % of full scale/K
4) Digital resolution	\pm % of full scale (which scale)
5) Data format returned of the application programme	Number of bits
6) Value of a LSB (least significant bit)	Binary, BCD, etc
7) Maximum permanent allowed overload (no damage)	mV, mA
8) Digital output reading under overload condition	V, mA
9) Type of input	For example, flag
10) Common-mode characteristics (d.c., a.c. 50 Hz, a.c. 60 Hz) if applicable	For example, differential
11) For other inputs (thermocouples, RTD, etc):	CMRR-dB, CMV-V
• type(s) sensor(s)	–
• measurement range(s)	J, K, T, etc.: Pt, 100, etc.
• linearization method	Min. °C to max. °C
	Internal or user-provided

7.10.2 Information on analogue input dynamic characteristics

Dynamic characteristics	Units and examples
1) Sample duration time (including setting time)	ms
2) Sample repetition time	ms
3) Input filter characteristics: <ul style="list-style-type: none"> • order • transition frequency 	– First, second, etc.. Hz
4) Maximum temporary deviation during each specified electrical interference test	± % of full scale

7.10.3 Information on analogue input general characteristics

General characteristics	Units and examples
1) Conversion method	Dual slope, S.A, etc..
2) Operating modes	Trig, self-scan, etc..
3) Type of protection	RC, opto-isolator, MOVs, etc..
4) Isolation potentials under normal operation between channel and a) other circuits (including ground), b) between channels, c) power supply(ies) and d) interface(s)	V –
5) External power supply data, if required	Technical data –
6) Common points between channel if any	Twisted pair, 50 m max
7) Type, length of cable, installation rules recommended to provide interference immunity	Month, years
8) Calibration or verification to maintain rated accuracy	–
9) Terminal arrangements	–
10) Typical example(s) of external connections	–
11) Effect of incorrect input terminal connection	–

7.10.4 Information on analogue input miscellaneous characteristics

Miscellaneous characteristics	Units and examples
1) Monotonicity with no missing codes	Yes, no
2) Crosstalk between channels at d.c., a.c. 50 Hz and a.c. 60 Hz	dB
3) Non-linearity	% of full scale
4) Repeatability at fixed temperature after specified stabilization time	% of full scale
5) Lifetime of electromagnetic relay multiplexers, if applicable	Number of cycles, of hours

7.11 Information on analogue outputs

Besides the type and standard range, the manufacturer shall provide the following information.

7.11.1 Information on analogue output static characteristics

Static characteristics	Units and examples
1) Output impedance in signal range (manufacturer should specify if this is in the on or off state)	Ω –
2) Analogue output error: <ul style="list-style-type: none"> • maximum error at 25 °C • temperature coefficient 	– ± % of full scale (which scale) ± % of full scale/K
3) Maximum error over full temperature range	± % of full scale (which scale)
4) Digital resolution	Number of bits
5) Data format returned of the application programme	Binary, BCD, etc
6) Value of a LSB (least significant bit)	mV, mA

7.11.2 Information on analogue output dynamic characteristics

Dynamic characteristics	Units and examples
1) Settling time for full-range change	ms
2) Overshoot	% of full scale
3) Maximum temporary deviation during each specified electrical interference test	± % of full scale

7.11.3 Information on analogue output general characteristics

General characteristics	Units and examples
1) Type of protection	Opto-isolator, etc.
2) Isolation potentials between channel and other circuits (including ground) and between channels under normal operation	V –
3) External power supply data, if required	Technical data
4) For current outputs with external supply, the maximum and minimum voltage drop across the output terminals in the full output range	V –
5) Type, length of cable, installation rules recommended to provide interference immunity	Twisted pair, 50 m max
6) Calibration or verification to maintain rated accuracy	Month, years
7) Terminal arrangements	–
8) Common points between channels, if any	–
9) Allowed type(s) of loads	Floating, grounded
10) Maximum capacitive load (for voltage outputs)	pF
11) Maximum inductive load (for current outputs)	mH
12) Typical example(s) of external connections	–
13) Output response at power up and power down	–
14) Effect of incorrect output terminal connection	–

7.11.4 Information on analogue output miscellaneous characteristics

Miscellaneous characteristics	Units and examples
1) Monotonicity	Yes, no
2) Crosstalk between channels at d.c., a.c. 50 Hz and a.c. 60 Hz	dB
3) Non-linearity	% of full scale
4) Repeatability at fixed temperature after specified stabilization time	% of full scale
5) Output ripple	% of full scale

7.12 Information on communication interfaces

If the manufacturer provides communication interfaces to other than his own equipment, he shall provide the necessary information for correct operation. This may be achieved by referencing a specific standard or specification together with details of any options such as baud rate, type of cable to be used, etc.

7.13 Information on main processing unit(s) and memory(ies) of the PLC-system

Information to be provided by the manufacturer for main processing unit(s) and memory(ies) shall be:

- organization, capacity of programme memory;
- organization, capacity of data memory and number of bits per word;
- memory type(s) (i.e. CMOS-EPROM, etc.) available;

- memory back-up functionality and service requirements if any;
- data, constraints and procedures to determine a desired configuration (racks, cables, bus expanders, power supply unit, maximum number of I/Os per type, maximum number of I/O modules, etc.);
- description of the programming languages supported by the PLC-system (combination of the PADT and the main processing unit(s));
- to what extent the languages defined in IEC 61131-3 are supported, including the differences if any (objects, instructions, semantic and syntactic rules, etc.);
- calculation methods to determine every memory utilization (user's application programme and data, firmware programme and data where applicable) and average values of every relevant time (scan time(s), system response time(s), transfer time(s), execution time(s));
- mechanisms in which I/Os are processed (i.e. use of I/O image registers periodically refreshed by the system, immediate “get/put” type instructions, interrupt and event-driven programmes, etc.) and their effect on the following subjects:
 - system response time(s);
 - restart capabilities (i.e. cold, warm, hot restart);
 - detailed times for inputs, outputs, processing, etc.;
 - effect of non-permanently installed peripherals on every relevant time (see item 8 of this subclause) when they are plugged/unplugged, connected/disconnected to their PLC-system interface;
 - PLC-system status information concerning cold, warm and hot restart if applicable. Description and usage of programmable timers usable to determine the process-dependent difference between warm and hot restart;
 - self-test and diagnostic functions implemented (see 5.8)

7.14 Information on remote input/output stations (RIOSs)

The manufacturer shall provide the following information:

- specifications for the selection of adequate cables and other devices needed for the communication link;
- specifications for proper installation of the whole system (including proper selection of energy source(s));
- type of I/O communication network (point-to-point, star, multi-drop, ring, etc.);
- principles, procedures and transmission speeds used on the communication link and their capability to transfer data from and to the RIOSs with respect to error coding/detection and to the delays of transmission in the best, most likely and worst cases;
- effect on transfer time(s) introduced to provide remote input information and RIOSs status to the user's application programme and to transmit its logical decisions to remote outputs;
- specified values and delays according to 5.6;
- configuration related data: maximum number of RIOSs in 1 single PLC-system configuration, min/max size of each;
- which I/O modules of the total I/O system may not be used in RIOSs and/or which of their functions are altered if any;
- type, architecture and characteristics of redundancy if provided;
- modems/repeaters if applicable. Maximum distance with or without repeaters;
- terminating devices if required;
- physical characteristics of the communication interface including isolation characteristics, maximum acceptable common mode voltage, built-in short-circuit protections, etc.;

- type of standard link interface (i.e. RS 232, RS 422, RS 485, RS 511, etc.);
- functional and safety earthing specifications;
- procedures for making/breaking logical and physical connection of a RIOS to a PLC-system (for example, “on line”).

7.15 Information on peripherals (PADTs, TEs, HMIs)

The manufacturer shall provide the following information through convenient documentation and marking:

- clear warnings and precautions to be observed when using functions enabling alteration of control conditions such as PLC-system status modification, changing of data or programmes in the memory, forcing input or output signal, etc.;
- usability of peripherals at RIOSs;
- service conditions for peripherals which are intended for use in an environment less severe than stated in Clause 4 (such peripherals may need to be remotely connected to the rest of the PLC-system through communication lines);
- specifications for the selection of adequate cables and other devices needed for the communication link;
- specifications for proper installation of the whole system (including proper selection of energy source(s));
- type of communication network (point-to-point, star, multi-drop, ring, etc.)
- principles, procedures and transmission speeds used on the communication link and their capability to transfer data from and to the RIOSs with respect to error coding/detection and to the delays of transmission in the best, most likely and worst cases;
- terminating devices if required;
- physical characteristics of the communication interface including isolation characteristics, maximum acceptable common mode voltage, built-in short-circuit protections, etc.;
- type of standard link interface (i.e. RS 232, RS 422, RS 485, etc.);
- functional and safety earthing specifications.

7.16 Information on self-tests and diagnostics

The manufacturer shall provide the following information through convenient documentation and marking:

- description of tests and diagnostics which are implemented and when they are executed (i.e. permanently, periodically, upon user's application programme request, during start-up procedure, etc.);
- correct functioning state and driving conditions of the alarm output(s) (see 5.8).

8 Electromagnetic compatibility (EMC) requirements

8.1 General

As potential radiating equipment, the installed PLC-system and other devices may emit conducted and radiated electromagnetic interference.

As potential receiving equipment the PLC-system may be effected by externally generated conducted interference, radiated electromagnetic fields and electrostatic discharges.

The requirements of 8.2 and 8.3 are intended to characterize the EMC performance of the PLC-system equipment and are the responsibility of the manufacturer. The user, advised by the manufacturer, is responsible for the electromagnetic compatibility of the product as installed.

Since the PLC-system is only 1 component of the overall automated system, this standard does not deal with the EMC compatibility of the overall automated system.

If an optional EMC enclosure (for example, cabinet) or other protection device (for example, filter) is specified by the manufacturer it shall be included as part of the equipment under test (EUT).

The EMC enclosure port is the physical boundary of the PLC-system through which electromagnetic fields may radiate or impinge. See 3.46.

8.2 Emission requirements

8.2.1 General requirements for emission

For emissions, the objective of the requirements given in Table 27 is to ensure protection of the radiofrequency spectrum.

8.2.2 Emission limits in the low-frequency range

Since the PLC-system is not connected to the public mains, there is no requirement up to 150 kHz.

8.2.3 Emission limits in the high-frequency range

Table 27 – Emission limits

Port	Frequency range	Severity level (normative)	Severity level (optional)	Basic standard
Enclosure port (radiated)	–	Measured at 10 m distance	Measured at 30 m distance	CISPR 11 Class A, Group 1
	30-230 MHz	40 dB(μ V/m) quasi-peak	30 dB(μ V/m) quasi-peak	
	230-1 000 MHz	47 dB(μ V/m) quasi-peak	37 dB(μ V/m) quasi-peak	
AC power port (conducted)	0,15-0,5 MHz	79 dB(μ V) quasi-peak		CISPR 11 Class A, Group 1
	–	66 dB(μ V) average		
	–	–		
	0,5-30 MHz	73 dB(μ V) quasi-peak		
	–	60 dB(μ V) average		

NOTE Emission limits at frequencies above 1 000 MHz are under consideration.

Requirements of this subclause are verified in accordance with 9.3 and 9.4.

8.3 EMC immunity requirements

8.3.1 General

If a product is to be used in multiple zones, then it shall be designed and tested to the most severe combination of requirements for its intended zones.

PLC's are designed for Zone B (which encompasses Zone A) unless otherwise indicated by manufacturer's information.

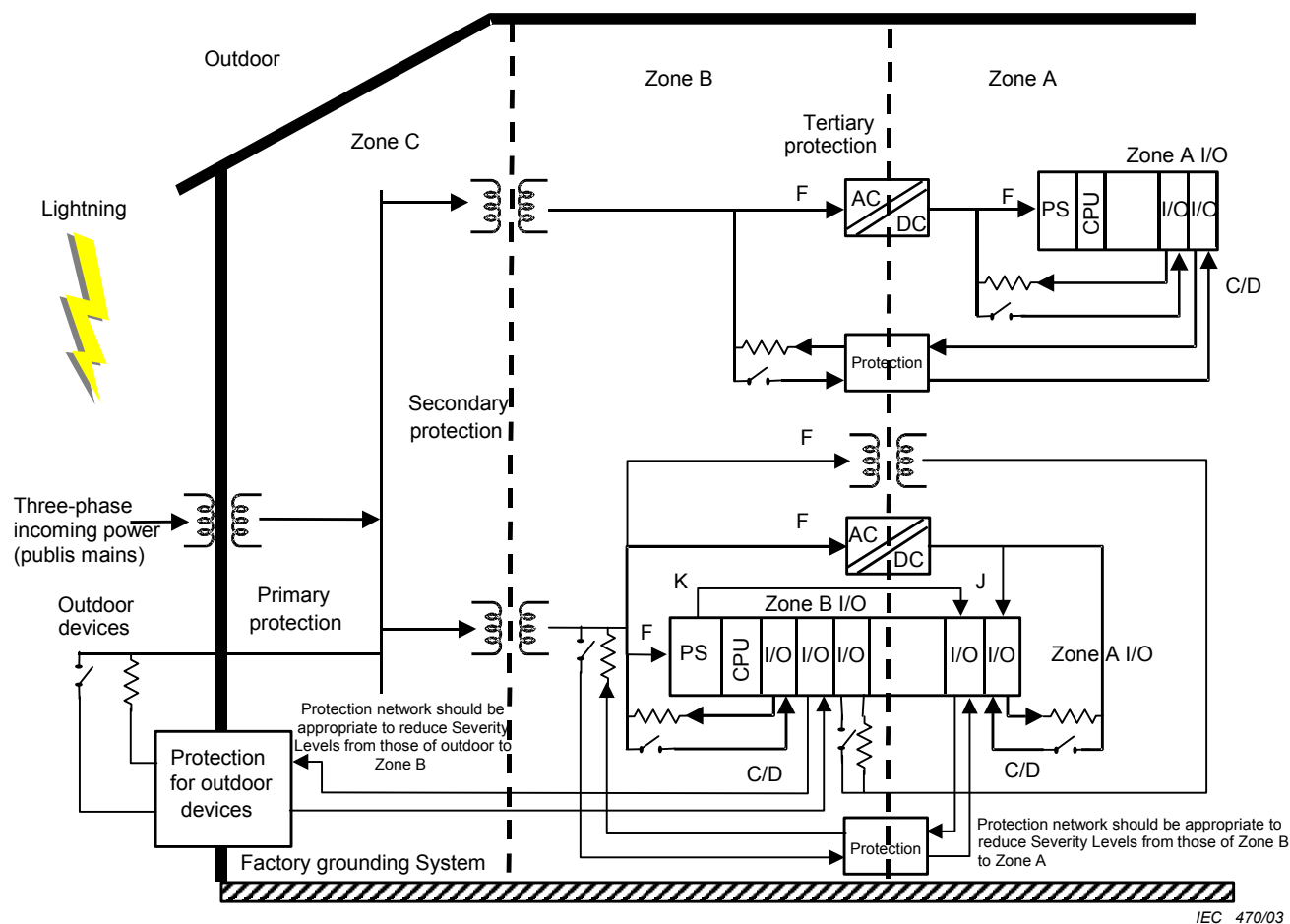

IEC 470/03

Figure 11 – EMC immunity zones

The picture shown in Figure 11 is meant to describe the EMC and interference coupling mechanisms in a factory environment. Zone separation is determined by power distribution and I/O wiring. Dotted lines are not meant to indicate physical separation or segregation. The letters referred to in Figure 11 (F, K, C, D, etc.) correspond to those referred to in Figure 2. They describe interface/ports.

Zone C = Factory mains (isolated from public mains by dedicated transformer), primary surge protection and severe interference coupling.

Zone B = Dedicated power distribution, secondary surge protection and moderate industrial interference coupling.

Zone A = Local power distribution, protected, I/O impedance limiting and low interference coupling.

Table 28 – EMC immunity zones

EMC zones	EMC considerations		
Zone C	Factory mains distribution High rated voltage	Primary surge protection	Severe voltage surge coupling 4 000 V
Zone B	Dedicated power distribution ≤300 V rated voltage	Secondary surge protection I/O impedance limiting	Moderate voltage surge coupling 2 000 V
Zone A	Local power distribution ≤120 V rated voltage ≤100 V rated voltage ≤50 V rated voltage	I/O impedance limiting	Low-voltage surge coupling 1 000 V 800 V 500 V

8.3.2 Performance criteria

Table 29 – Criteria to prove the performance of a PLC-system against EMC disturbances

Performance criterion		
Criterion	Operation	
	During test	After test
A	The PLC-system shall continue to operate as intended. No loss of function or performance, according to PFVPs (2.5)	The PLC-system shall continue to operate as intended
B	Degradation of performance accepted Examples: analogue values vary within manufacturer-specified limits, communication delay times vary within manufacturer-specified limits, flickering on HMI display, etc. No change of operating mode Examples: loss of data or uncorrected errors in communication, unintentional state changes of digital I/O which are seen by the system or test set-up, etc. No irreversible loss of stored data, according to PFVPs (2.5)	The PLC-system shall continue to operate as intended. Temporary degradation of performance must be self-recoverable
C	Loss of functions accepted, but no destruction of hardware or software (programme or data)	The PLC-system shall continue to operate as intended automatically, after manual restart or power off/power on

8.3.3 General radiated immunity limits

Table 30 – Radiated immunity and enclosure ports (1) Conducted immunity, Zones A-B

Environmental phenomenon	Basic standard	Units	Test severity	Test set-up	Normative items	Performance criteria
Electrostatic discharge	IEC 61000-4-2	kV	±4 Contact ±8 Air	Table 36	(1)	B B
Radio-frequency Electro-magnetic field Amplitude modulated	IEC 61000-4-3	GHz MHz MHz V/m % AM, 1kHz Sinusoidal	1,4-2,0 800-960 80-1 000 10 80	Table 37	(4)	A
Power frequency magnetic fields	IEC 61000-4-8	Hz	60	Table 38	(2), (3)	A
		A/m	30			
		Hz	50	Table 38	(2), (3)	A
		A/m	30			

(1) The ESD test shall be applied to (a) operator accessible devices (for example, HMI, PADT and TE) (b) enclosure ports, (c) service accessible parts (for example, switches, keyboards, protective/functional earth, module housing, communications ports with connectors in place and metal connectors) which are not protected from casual access. The ESD test shall not be applied to communications ports without connectors in place, I/O ports or power ports.

(2) This test is meant to test equipment sensitivity to magnetic fields normally occurring on the factory floor. The test is only applicable to equipment containing devices susceptible to magnetic fields, such as Hall effect devices, CRT displays, disk drives, magnetic memories and similar equipment. The basic PLC does not normally contain such devices; however, other devices, such as HMI, may. The test is not meant to simulate high-intensity magnetic fields such as those, for example, associated with welding and induction heating processes. This requirement may be satisfied by the test being applied to the sensitive device at the device manufacturer.

(3) There will be no deviation up to 3 A/m. Above 3 A/m the manufacturer will specify the allowed deviation for CRT display interfaces.

(4) This level does not represent the field emitted by a transceiver in close proximity to the PLC-system.

Zone B levels are the most typical industrial environmental levels.

Table 31 – Conducted immunity, Zone B

	Environmental phenomenon	Fast transient burst	High energy surge	Radiofrequency interference
	Basic standard	IEC 61000-4-4	IEC 61000-4-5	IEC 61000-4-6
	Test set-up	Table 39	Table 40	Table 41
	Performance criteria	B	B	A
	Normative items		(1), (2)	
Interface/Port Figure 2 (designation)	Specific interface/port			
Data communication (Al and Ar for I/O racks and Be, Bi and E for peripherals)	Communication	–	–	–
	Shielded cable	1 kV (5)	1 kV CM	3 V (5)
	Unshielded cable	1 kV (5)	No test	3 V (5)
Digital and analogue I/Os (C and D)	AC I/O (unshielded)	2 kV (5)	2 kV CM 1 kV DM	3 V (5)
	Analogue or DC I/O (unshielded)	1 kV (5)	0,5 kV CM 0,5 kV DM	3 V (5)
	All shielded lines (to shield)	1 kV (5)	1 kV CM	3 V (5)
Mains power (F)	AC power	2 kV	2 kV CM 1 kV DM	3 V
	DC power	2 kV (4)	1 kV CM 0,5 kV DM	3 V
Protective earthing (G)	Protective earth	No test	No test	No test
Functional earthing (H) (3)	Functional earth	1 kV (5)	No test	3 V
I/O power (J) and auxiliary power output (K)	I/O and a.c. auxiliary power	1 kV	2 kV CM 1 kV DM	3 V
	I/O and d.c. auxiliary power	1 kV (4)	0,5 kV CM 0,5 kV DM	3 V
<p>(1) Not applicable to d.c. power ports intended for connection to a battery or a rechargeable battery that must be removed or disconnected from the equipment for recharging. The test is applicable to d.c. power ports, unless cables are specified ≤ 10 m a.c. Power ports to be tested regardless of specified length.</p> <p>(2) For non-mains power ports with cables specified ≤ 30 m, no test is needed.</p> <p>(3) If this port is used for shield returns, this port would be tested as a consequence of the shielded cable test. Otherwise, no specific test of this port is required.</p> <p>(4) For ports with cables specified ≤ 10 m, no test is needed.</p> <p>(5) For ports with cables specified ≤ 3 m, no test is needed.</p>				

Zone A levels apply where installation practices reduce industrial environmental levels below those of Zone B. Referring to Figure 11, these may be installation of protection networks, a.c./d.c. converters, isolation transformers, surge suppressers, etc.

Table 32 – Conducted immunity, zone A

	Environmental phenomenon	Fast transient burst	High energy surge	Radiofrequency interference
	Basic standard	IEC 61000-4-4	IEC 61000-4-5	IEC 61000-4-6
	Test set-up	Table 39	Table 40	Table 41
	Performance criteria	B	B	A
	Normative items		(1), (2)	
Interface/Port Figure 2 (designation)	Specific interface/port			
Data communication (AI and Ar for I/O racks and Be, Bi and E for peripherals)	Communication	–	–	–
	Shielded cable	0,5 kV (5)	0,5 kV CM	3 V (5)
	Unshielded cable	0,5 kV (5)	No test	3 V (5)
Digital and analogue I/Os (C and D)	AC I/O (unshielded)	1 kV (5)	1 kV CM 0,5 kV DM	3 V (5)
	Analogue or d.c. I/O (unshielded)	0,5 kV (5)	No test	3 V (5)
	All shielded lines (to shield)	0,5 kV (5)	1 kV CM	3 V(5)
Mains power (F)	AC power	1 kV	1 kV CM 0,5 kV DM	3 V
	DC power	1 kV (4)	0,5kV CM	3 V
Protective earthing (G)	Protective earth	No test	No test	No test
Functional earthing (H) (3)	Functional earth	0,5 kV (5)	No test	3 V
I/O power (J) and auxiliary power output (K)	I/O and a.c. auxiliary power	0,5 kV	1 kV CM 0,5 kV DM	3 V
	I/O and d.c. auxiliary power	0,5 kV (4)	No test	3 V
<p>(1) Not applicable to d.c. power ports intended for connection to a battery or a rechargeable battery that must be removed or disconnected from the equipment for recharging. The test is applicable to d.c. power ports, unless cables are specified ≤ 10 m. AC power ports to be tested regardless of specified length.</p> <p>(2) For non-mains power ports with cables specified ≤ 30 m, no test is needed.</p> <p>(3) If this port is used for shield returns, this port would be tested as a consequence of the shielded cable test. Otherwise, no specific test of this port is required.</p> <p>(4) For ports with cables specified ≤ 10 m, no test is needed.</p> <p>(5) For ports with cables specified ≤ 3 m, no test is needed.</p>				

Conditions of use may require installation in Zone C. The manufacturer may elect to provide equipment for this installation by utilizing the levels given in Annex D.

Requirements of this subclause are verified in accordance with 9.5, 9.6, 9.7, 9.8, 9.9, and 9.10.

8.3.4 Voltage drops and interruptions power ports

These limits apply to the mains power interface/port (F) in Figure 2.

For short disturbances of the supply as defined in Table 33, the PLC-system (including RIOSs (see 5.6) and non-permanently installed peripherals) shall maintain normal operation.

For longer interruptions of the supply(ies), the PLC-system shall either maintain normal operation or go to a predefined state and have a clearly specified behaviour until normal operation is resumed.

NOTE Outputs and fast responding inputs energized by the same supply(ies) will respond to these power supply variations.

Table 33 – Voltage drops and interruptions

(5)	(3), (4)	Maximum interruption Time	Time interval between drops	Low voltage
DC supply	Severity level PS1	1 ms	≥1 s	Any voltage under lower operational limit $U_{e\ min}$ (2)
–	Severity level PS2	10 ms	≥1 s	
AC supply	–	0,5 period (1)	≥1 s	

(1) Any arbitrary phase angle (see 9.12).
 (2) $U_{e\ min}$ is the U_e at minimum tolerance in Table 6.
 (3) PS1 applies to PLC-systems supplied by battery.
 (4) PS2 applies to PLC-systems energized from rectified a.c. supplies and/or long d.c. lines.
 (5) Voltage interruptions are from $U_{e\ min}$

Requirements of this subclause are verified in accordance with 9.12.

8.4 Requirements for EMC tests and verifications

Test and verifications for EMC shall be performed by the manufacturer, in accordance with Clause 9.

8.5 Requirements for information on EMC

Information on EMC shall be provided by the manufacturer, in accordance with 10.

9 Electromagnetic compatibility (EMC) type tests and verifications

For EMC type tests, also refer to pass-fail criteria (Table 29).

9.1 Electromagnetic compatibility-related tests

The conducted and radiated emissions and immunity of the PLC-system must be tested according to the manufacturer's installation guideline.

All EMC tests shall be conducted in a well-defined and reproducible manner.

All EMC tests are type tests.

It may be determined from consideration of the electrical characteristics and usage of a particular apparatus that some tests are inappropriate and therefore unnecessary. In such cases, it is required that the decision and justification not to test is recorded in the test report.

9.2 Test environment

The EUT is located in the specified test site and any auxiliary equipment shall be located outside the influence of the test environment. For certain environments, it is appropriate to

expect that potential interference victims will be located at least a minimum distance from the radiator. In the industrial environment, the expected distance is 30 m.

All input/output cables can be normally looped back for monitoring and testing and/or can be terminated with a representative load.

In general, for multi-channel I/O, 1 circuit may be tested to represent all channels. On and off states and/or points representing the range of allowed loads must be tested.

9.3 Measurement of radiated interference

Table 34 – Radiated emission measurement

Reference test	CISPR 11
Test configuration	In accordance with CISPR 11 and CISPR 16-1 (2)
Distance and method (1)	See Table 27
Details of mounting/support	Installed according to manufacturer's specification
–	–
Frequency range	See Table 27
–	–
Class A Limits	See Table 27

(1) The measurement distance is the distance between the EUT or its enclosure and the receiving antenna for test site measurements, or the measurement distance is the distance between the exterior wall of the building in which the equipment is situated and the receiving antenna, for *in situ* measurements.

(2) Tests may be conducted on radiation test sites, which do not have the physical characteristics of an open-air test site. An alternative radiation test site in the frequency range 30 MHz to 1 GHz shall be acceptable if the horizontal and vertical site attenuation measurements made according to 16.6 of CISPR 16-1 are within ± 4 dB of the theoretical site attenuation as given in CISPR 16-1 Table G.1, G.2, or G.3. Alternative radiation test sites shall allow for, and be validated for, the measurement distance in the frequency range of 30 MHz to 1 GHz. Evidence shall be obtained to show that such alternative sites will yield valid results.

9.4 Measurement of conducted interference

Table 35 – Conducted emission measurement

Reference test	CISPR 11
Test configuration and method	In accordance with CISPR 11, CISPR 16-1 and -2
–	–
Applicable ports	AC power port (F) (1)
–	–
Details of mounting/support	Installed according to manufacturer's specifications
–	–
Frequency range	See Table 27
–	–
Class A limits (2)	See Table 27

(1) DC mains are under consideration.

(2) Impulse interference (click) which occurs less than 5 times per minute is not considered. For clicks appearing more often than 30 times per minute the limits apply. For clicks appearing between 5 and 30 times per minute a relaxation of the limits of $20 \log 30/N$ (where N is the number of clicks per minute) is allowed.

9.5 Electrostatic discharge

Table 36 – Electrostatic discharge immunity test

Reference test	IEC 61000-4-2
EUT configuration – Initial measurements – Details of mounting/support – Selection of application points – – – – –	According to manufacturer's specifications – According to PFVP (2.5) – According to manufacturer's specifications and IEC 61000-4-2 provisions – The ESD test shall be applied to (a) operator-accessible devices (for example, HMI, PADT and TE) (b) enclosure ports, (c) service accessible parts (for example, switches, keyboards, protective/functional earth, module packaging, communications ports with connectors in place and metal connectors) which are not protected from casual access. The ESD test shall not be applied to communications ports without connectors in place, I/O ports or power ports
Test application Contact discharge Air discharge – Test levels – Time between two discharges Number of discharges on each selected point	– EUT, horizontal and vertical coupling planes EUT – See Table 30 or Table D.1 – ≥1 s Ten discharges after the equipment is discharged to earth
Measurement and verification during loading – Performance criteria	According to PFVP (2.5) – See Table 30 or Table D.1 (1)
(1) If the system deviates only once during the test, a second trial of 10 discharges shall performed; if more non-allowed deviations are observed, failure of the ESD test shall be declared.	

9.6 Radiofrequency electromagnetic field – Amplitude modulated

Table 37 – Radiated electromagnetic field immunity test

Reference test	IEC 61000-4-3
EUT configuration	According to manufacture's specifications
–	–
Initial measurements	According to PFVP (2.5)
–	–
Details of mounting/support	The EUT is placed in the calibrated test field
–	–
Frequency range to be swept	See Table 30 or Table D.1 (2), (Note)
–	–
Modulation	See Table 30 or Table D.1
–	–
Sweep speed	$1,5 \times 10^{-3}$ decade/s
–	–
Test field strength	See Table 30 or Table D.1 (1)
Measurement and verification during loading	According to PFVP (2.5)
–	–
Performance criteria	See Table 30 or Table D.1
<p>(1) Except for the ITU broadcast frequency bands: 87-108 MHz, 174-230 MHz and 470-790 MHz where the level shall be 3 V/m.</p> <p>(2) Conducted immunity requirements 9.10, for 26-80 MHz may be satisfied by utilizing this test over the 26-80 MHz range. See Table 41.</p>	
NOTE See also Annex H, IEC 61000-4-3.	

9.7 Power-frequency magnetic fields

Table 38 – Power-frequency magnetic field immunity test

Reference test	IEC 61000-4-8
EUT configuration	According to manufacture's specifications
–	–
Initial measurements	According to PFVP (2.5)
–	–
Details of mounting/support	The EUT is immersed in the magnetic field of a 1 m × 1 m induction coil.
–	–
–	–
Frequency (power line)	See Table 30 or Table D.1
–	–
Test condition	Immersion method in continuous field
–	–
Test field strength	See Table 30 or Table D.1
Measurement and verification during loading	According to PFVP (2.5)
Performance criteria	See Table 30 or Table D.1 (1)
(1) For CRTs, the performance criteria is B, if the field is $\geq 3A/m$.	

9.8 Fast transient bursts

Table 39 – Fast transient burst immunity test

Reference test	IEC 61000-4-4
EUT configuration	According to manufacturer's specifications
–	–
Initial measurements	According to PFVP (2.5)
–	–
Details of mounting/support	The EUT shall be such as to eliminate the radiated EMI received on I/O wiring by the specified capacitive coupling
–	–
–	–
Severity level at rated voltage	See Table 31, Table 32 or Table D.2
–	–
Duration	1 min minimum
–	–
Application ports/methods	–
–	–
Communication (Al, Ar, Be, Bi, and E), I/O (C and D), I/O Power (J) and auxiliary power output (K)	50-200 pF capacitive clamp coupling
–	–
AC/DC power (F)	33 nF direct coupling
Measurement and verification during loading	According to PFVP (2.5)
Performance criteria	See Table 31, Table 32 or Table D.2
NOTE The repeatability of this test is closely related to the number and relative position of wires within the capacitive coupling clamp.	

9.9 High-energy surges

Table 40 – High-energy surge immunity test

Reference test	IEC 61000-4-5
EUT configuration	According to manufacturer's specifications
–	–
Initial measurements	According to PFVP (2.5)
–	–
Details of mounting/support	According to manufacturer's specifications
–	–
Severity level at rated voltage	See Table 31, Table 32 or Table D.2
–	–
Number of discharges	Five each in positive and negative polarities
–	–
Repetition rate	1/min maximum
–	–
Application ports/methods	Direct coupling by wired capacitance method
–	–
Shielded communication (Al, Ar, Be, Bi, and E) and shielded I/O (C and D)	2Ω/10nF between shield and reference ground
–	–
Unshielded communication (Al, Ar, Be, Bi, and E) and unshielded I/O (C and D),	42Ω/0,5 μF CM 42Ω/0,5 μF DM
I/O Power (J) and auxiliary power output (K)	–
–	–
AC/DC power (F)	12 Ω/9 μF CM 2Ω/18μF DM
Measurement and verification during loading	According to PFVP (2.5)
Performance criteria	See Table 31, Table 32 or Table D.2

9.10 Conducted radiofrequency interference

Table 41 – Conducted RF immunity test

Reference test	IEC 61000-4-6 (2), (Note1)
EUT configuration	According to manufacturer's specifications
–	–
Initial measurements	According to PFVP (2.5)
–	–
Details of mounting/support	The EUT shall be such as to eliminate the radiated EMI received on I/O wiring by the specified magnetic coupling
–	–
Severity level at rated voltage	See Table 31, Table 32 or Table D.2
–	–
Frequency range to be swept	150 kHz-80 MHz (1), (Note 2)
–	–
Modulation	80 % AM by a 1 kHz sinusoidal
–	–
Sweep speed	$1,5 \times 10^{-3}$ decade/s
–	–
Test level (unmodulated)	See Table 31(3), Table 32 (3) or Table D.2
–	–
Application points	All cable between EUT and clamp or CDN is as short as possible
–	(max. 0,3 m)
–	–
Communication (Al, Ar, Be, Bi, and E), I/O (C and D), a.c./d.c. power (F), functional earthing (H), I/O power (J) and auxiliary power output (K)	–
	–
	CDN, EM or current coupling clamp
	–
Measurement and verification during loading	According to PFVP (2.5)
Performance criteria	See Table 31, Table 32 or Table D.2
<p>(1) There are no new radiators below 26 MHz. Additionally, history has shown no difficulty below 26 MHz. So, no test is necessary below 26 MHz. The 0,15-26 MHz band is exempted from test.</p> <p>(2) Conducted Immunity requirements, for 26-80 MHz, may be satisfied by utilizing the radiated electromagnetic field immunity test over the 26-80 MHz range. See Table 37.</p> <p>(3) For the 3 V open-circuit test level, if (2) is exercised, a 10 V/m field strength should be used.</p>	
NOTE 1 See also Annex H, IEC 61000-4-3.	
NOTE 2 Notes on test level selection and Annex B of IEC 61000-4-6.	

9.11 Damped oscillatory wave (for zone C only)

Table 42 – Damped oscillatory wave immunity test

Reference test	IEC 61000-4-12
EUT configuration	According to manufacturer's specifications
–	–
Initial measurements	According to PFVP (2.5)
–	–
Details of mounting/support	According to manufacturer's specifications
Test description	–
Waveform	Damped oscillating wave the envelope of which reaches 50 % of the initial peak value after 3 to 6 cycles (verify the sinusoidal shape of the wave)
–	–
–	–
Frequency	1 MHz \pm 10 %
Source impedance	200 Ω \pm 10 % unshielded
Repetition rate	400/s
Test duration	2 s minimum
Length to connection	2 m maximum
–	–
Severity level at rated voltage	See Table D.2
–	–
Application points/method: I/O (C and D), a.c./d.c. power (F), I/O power (J) and auxiliary power output (K)	CM, DM
–	–
Measurement and verification during loading	According to PFVP (2.5)
Performance criteria	See Table D.2

9.12 Voltage drops and interruptions - Power port type tests and verifications

Power ports are mains power input port, port F, Figure 2.

Perform the proper functional verification procedure of 2.5 during tests.

Table 43 – Voltage drops and interruptions immunity test

Reference test	None
EUT configuration	According to manufacturer's specifications
Initial measurements	According to PFVP (2.5)
Supply voltage and frequency	U_e min to 0 (zero) V, F_n
Test description	–
AC supply interruption	–
Duration base	0,5 period, starting at zero-crossing (1), (2)
Number of trials	20
Time interval between trials	1 s < time interval < 10 s
–	–
DC supply interruption	–
Duration	PS1: ≥ 1 ms; PS2: ≥ 10 ms (2)
Number of trials	20
Time interval between trials	1 s < time interval < 10 s
Measurement and verification during loading	According to PFVP (2.5)
–	Normal operation shall be maintained (3)
–	–
Verification after tests	According to PFVP (2.5)
Performance criteria	A

(1) Optionally, the manufacturer may elect to interrupt supply at a random phase angle.

(2) The manufacturer may state longer interruptions.

(3) Fast responding inputs energized by the same power supply may be affected temporarily during the disturbance but shall resume normal operation after the disturbance.

10 Electromagnetic compatibility (EMC) information to be provided by the manufacturer

Information to be made available can be in other than printed form.

General rules of installation are noted in IEC 61131-4. Specific installation information shall be provided by the manufacturer.

The manufacturer shall state if its devices are intended to be used under normal service conditions or in a less severe environment (for example, office environment). If the PLC is intended for other than Zone B (which encompasses Zone A), the manufacturer shall state the intended zone.

The test report shall describe all the tests, the rationale for the selection of the typical (representative) configuration of the EUT and the test results.

The EUT software used during the test shall be documented.

11 Safety requirements

This section specifies safety requirements for PLC-systems equipment (i.e. MPU, RIOs, permanently/non-permanently installed peripherals). Components connected to the mains power supply of the installation, such as power supplies, I/O modules, communication interfaces, and memory subsystems are also subject to the applicable provisions of this clause.

11.1 Protection against electrical shock

Protection against electric shock of the PLC-system shall be maintained in normal and single-fault condition. Accessible parts of equipment shall not be, or in the case of a single fault become, hazardous live. Although they are principally directed at enclosed equipment, these requirements also apply to open equipment. When applied to open equipment, the equipment shall be considered to be installed, according to the manufacturer's instructions.

Protection shall be by compliance with the dielectric strength requirements in 11.1.4, the operator accessibility requirements of 11.1.5, the normal condition requirements of 11.1.6, the single-fault requirements in 11.1.7 and the clearance and creepage requirements in 11.4.

SELV/PELV circuits do not pose a risk of electric shock and do not require additional evaluation.

11.1.1 Permissible limits for accessible parts

To ensure that accessible parts are not hazardous live, the voltage, current, charge or energy between an accessible part and reference test earth, or between any 2 accessible parts on the same piece of equipment within a distance of 1,8 m (over a surface or through air), shall not exceed the values of 11.1.1.1 in normal condition nor of 11.1.1.2 in single-fault condition.

The accessible voltage shall be measured. If the voltage is below the limit of 11.1.1.1 or 11.1.1.2 as applicable, accessible current and capacitance need not be measured. If the voltage exceeds that value, the current and capacitance shall be measured.

11.1.1.1 Values in normal condition

Values above the levels of a), b) or c) in normal condition are deemed to be hazardous live.

- a) The voltage levels are a.c. 30 V r.m.s. and 42,4 V peak or d.c. 60 V.
- b) If the voltage exceeds one of the values of a), the current levels are
 - a.c. 0,5 mA r.m.s. for sinusoidal waveforms, 0,7 mA peak for non-sinusoidal waveform or mixed frequencies, or d.c. 2 mA, when measured with the measuring circuit of IEC 61010-1, Annex A, Figure A.1. Alternatively, the measuring circuit of IEC 61010-1, Annex A, Figure A.2 can be used if the frequency does not exceed 100 Hz;
 - a.c. 70 mA r.m.s. when measured with the measuring circuit of IEC 61010-1, Annex A, Figure A.3.

NOTE This relates to possible burns at higher frequencies.

- c) If the voltage exceeds one of the values of a), the charge or energy of capacitance levels are
 - 45 μ C charge for voltages up to 15 kV peak or d.c.;
 - 350 mJ stored energy for voltages above 15 kV peak or d.c.

11.1.1.2 Values in single-fault condition

Values above the levels of a), b) or c) in single-fault condition are deemed to be hazardous live.

- a) The voltage levels are a.c. 50 V r.m.s. and 70 V peak or d.c. 120 V.
- b) If the voltage exceeds one of the values of a), the current levels are
- a.c. 3,5 mA r.m.s. for sinusoidal waveforms, 5 mA peak for non-sinusoidal waveform or mixed frequencies, or d.c. 15 mA, when measured with the measuring circuit of IEC 61010-1, Annex A, Figure A.1. Alternatively, the measuring circuit of IEC 61010-1, Annex A, Figure A.2 can be used if the frequency does not exceed 100 Hz;
 - a.c. 500 mA r.m.s. when measured with the measuring circuit of IEC 61010-1, Annex A, Figure A.3.
- NOTE This relates to possible burns at higher frequencies.
- c) If the voltage exceeds one of the values of a), the capacitance levels are those of IEC 61010-1, Figure 2.

11.1.2 Open PLC-system equipment

Open PLC-system equipment is equipment that may have live electrical parts accessible, for example, a main processing unit.

Protection against electric shock shall be provided for those interfaces that are intended for operator access (see Table 44 for clarification). No other means of protection against electric shock are required except the enclosure required for the ultimate application.

Open equipment is to be incorporated into other assemblies manufactured to provide safety.

11.1.3 Enclosed PLC-system equipment

Enclosed PLC-system equipment is equipment which is enclosed on all sides, with the possible exception of its mounting surface, to prevent personnel from accidentally touching live or moving parts contained therein, to protect the equipment against ingress of 12,5 mm diameter and greater solid foreign bodies, and meeting requirements of mechanical strength, flammability, and stability (where applicable). The protection degree must be \geq IP20.

NOTE IP ratings as defined in IEC 60529.

As part of the requirement to provide protection against electrical shock, each entity of an enclosed PLC-system shall comply with the requirements of class I (see 11.1.3.1), class II (see 11.1.3.2), class III (see 11.1.3.3) or a mix thereof. The protection degree shall be \geq IP20.

Protection against electric shock shall be provided for those interfaces that are intended for operator access (see Table 44 for clarification).

11.1.3.1 Class I equipment

Class I equipment is equipment in which protection against electric shock does not rely on basic insulation only, but which includes an additional safety precaution in such a way that means are provided for the connection of accessible conductive parts to the protective earth conductor in the fixed wiring of the installation in such a way that accessible conductive parts cannot become live in the event of a failure of the basic insulation.

NOTE Class I equipment may have parts with double insulation or reinforced insulation, or parts operating at safety extra-low voltage.

Equipment for use with a flexible cord (such as PADTs) shall include a provision for a protective earth conductor that must be part of the cord set.

Accessible conductive parts of a PLC-system, which may become hazardous live in the event of a single fault, shall be connected to the protective circuit of the PLC-system. This does not apply to accessible conductive parts, such as screws, rivets and nameplates, which can become hazardous live under single-fault conditions.

When a part of the PLC-system is removed from the enclosure, for normal maintenance, for example, the protective circuits serving other parts of the PLC-system shall not be interrupted.

Protective earthing requirements shall be as specified in 11.9.

11.1.3.2 Class II equipment

Class II equipment is equipment in which protection against electric shock does not rely on basic insulation only, but in which additional safety precautions, such as double insulation or reinforced insulation are provided, there being no provision for protective earthing or reliance upon installation conditions.

Such equipment may be of one of the following types:

- 1) insulation-encased class II equipment: equipment having a durable and substantially continuous enclosure of insulating material which envelops all conductive parts, with the exception of small parts, such as nameplates, screws and rivets, which are isolated from hazardous live parts by insulation at least equivalent to reinforced insulation;
- 2) metal-encased class II equipment: equipment having a substantially continuous metal enclosure, in which double insulation is used throughout, except for those parts where reinforced insulation is used;
- 3) equipment which is a combination of types 1) and 2).

NOTE 1 The insulated enclosure of a class II equipment may form a part of the whole of the supplementary insulation or of the reinforced insulation.

NOTE 2 If equipment with double insulation and/or reinforced insulation throughout has a protective earthing terminal or contact, it is deemed to be of class I construction.

NOTE 3 Class II equipment may have parts operating at safety extra-low voltage.

Protective impedance may be used in lieu of double insulation provided the protective impedance limits the accessible conductive parts to a current of 5 mA or limits open-circuit voltage to values for SELV.

Class II equipment may be provided with means for maintaining the continuity of circuits (i.e. grounded internal components or conductive surfaces) provided that these circuits are double insulated from the accessible circuits of the equipment.

Class II equipment may be provided with means for connection to the earthing terminals for functional purposes (such as radiofrequency interference suppression) provided the double insulation system is still provided for protective purposes.

11.1.3.3 Class III equipment

Class III equipment is equipment in which protection against electric shock is provided by circuits supplied by safety extra-low voltage (SELV) and where voltages generated do not exceed the limits for SELV.

Class III equipment may be provided with means for connection to the earthing terminals for functional purposes (such as radiofrequency interference suppression).

Wiring for SELV/PELV circuits shall be either segregated from the wiring for circuits other than SELV/PELV, or the insulation of all conductors shall be rated for the higher voltage. Alternatively, earthed screening or additional insulation shall be arranged around the wiring for SELV/PELV circuits or around the wiring of other circuits.

11.1.4 Dielectric strength

The dielectric withstand type test of 12.2.1 shall be performed between all parts and circuits where basic, reinforced or double insulation are specified for protection against electric shock.

However, the dielectric withstand type test of 12.2.1 need not be carried out

- between SELV/PELV circuits and operator-accessible conductive parts (frames, enclosures, earth terminal, etc.);
- on units (parts of the basic PLC-system) which have been tested separately according to the relevant standards provided:
- when the values given in Table 52, Table 53 and Table 54 have been met, as appropriate, and
- their dielectric strength is not impaired by assembly.

11.1.5 Operator accessibility

Table 44 defines operator accessible ports of a PLC-system. Under special circumstances, some ports of either open or enclosed equipment may or may not be considered operator-accessible. This must be agreed upon between the manufacturer and the user.

Table 44 – Operator accessibility for open and enclosed equipment

Port	Operator accessible	
	Open equipment	Enclosed equipment
Al (communication interface/port for local IO extension rack)	No	Yes
Ar (communication interface/port for remote IO station)	No	Yes
Be (open communication interface/port also open to third-party devices (for example, personal computer used for programming instead of a PADT))	Yes	Yes
Bi (internal communication interface/port for peripherals)	No	No
C (interface/port for digital and analogue input signals)	No	Yes
D (interface/port for digital and analogue output signals)	No	Yes
E (serial or parallel communication interfaces/ports for data communication with third-party devices)	Yes	Yes
F (mains power interface/port)	No	Yes
G (interface/port for protective earthing)	No	Yes
H (interface/port for functional earthing)	No	Yes
J (I/O power interface/port used to power sensors and actuators)	No	Yes
K (auxiliary power output interface/port)	No	Yes

11.1.6 Protection in normal condition

Operator-accessible parts shall be prevented from becoming hazardous live under normal condition by one or more of the following means:

basic insulation;

NOTE This can be provided by suitable insulating materials, transformers, and opto-isolators.

b) enclosures or barriers;

c) protective impedance (see 11.1.7.3).

Enclosures and barriers shall meet the rigidity requirements of 11.7.2.2. If enclosures or barriers provide protection by insulation, it shall meet the requirements for basic insulation.

Clearances, creepage distances and insulation between accessible parts and hazardous live parts shall meet the requirements of 11.4 and the applicable dielectric strength requirements for basic insulation.

Compliance is checked

- a) by the determination of 12.1.2;
- b) by the requirements of 11.1.4 for dielectric strength of basic insulation;
- c) by the tests of 12.1.7 for rigidity of enclosures and barriers.

NOTE Materials, which can easily be damaged, are not considered to provide suitable insulation, for example lacquer, enamel, oxides, anodic films. Non-impregnated hygroscopic materials such as paper, fibres and fibrous material are also not considered to provide suitable insulation.

11.1.7 Protection in single-fault condition

Additional protection shall be provided to ensure that operator-accessible conductive parts are prevented from becoming hazardous live when a single fault occurs. This additional protection shall be provided by one or more of the following means:

- protective earthing and bonding (see 11.1.7.1),
- supplemental insulation (see 11.1.7.2), or
- protective impedance (see 11.1.7.3).

A single fault shall be considered to occur when a single component providing protection is unable to continue providing that protection.

Fault tests shall be performed on protective impedances, parts intended for short-term or intermittent operation, mains-connected transformers, outputs, cooling provisions and insulation. The testing shall consist of shorting, opening, blocking, etc. the part, as appropriate, while the equipment is operating under least favourable test conditions. Tests shall be applied one at a time.

After the application of the faults, the equipment shall be verified: not to have any operator-accessible parts hazardous live and to satisfy the dielectric withstand verification of 12.2.1, without pre-conditioning. If a fault is terminated by the opening of a fuse and if the fuse does not open within approximately 1 s, the equipment shall be operated for a period corresponding to the maximum specified fuse-opening time.

Requirements of this subclause are verified in accordance with 12.3.

11.1.7.1 Protective earthing and bonding

Operator-accessible conductive parts shall be bonded to the protective conductor terminal if they could become hazardous live in case of a single fault of the primary protective means specified in 11.1.6. Alternatively, such accessible parts shall be separated from parts that are hazardous live by a conductive protective screen or barrier bonded to the protective conductor terminal.

Operator-accessible conductive parts need not be bonded to the protective earth terminal if they are separated from all hazardous live parts by double insulation or reinforced insulation.

Compliance is checked by inspection.

11.1.7.2 Supplemental insulation

Clearances shall be in accordance with 11.4.1 and 11.4.2. Creepage distances shall be in accordance with 11.4.3. Fulfilling the requirements for double or reinforced insulation satisfies the requirements for protection under single-fault conditions.

11.1.7.3 Protective impedance

The protective impedance shall limit the voltage from becoming hazardous live under normal or single-fault conditions on operator-accessible parts or to values for SELV.

The use of a single component not liable to become defective in such a manner as to cause a risk of hazard is allowed (see IEC 61010-1, 14.6).

Requirements of this subclause are verified in accordance with 12.3.2.

11.2 Protection against the spread of fire

There are no requirements for protection against the spread of fire within limited power circuits as described in 11.3. Components and spacings within limited power circuits need not be evaluated.

Protection against the spread of fire must be evaluated between limited power circuits and other circuits.

If limited power circuits are not employed, all remaining subclauses of Clause 11 shall be applied with regard to spread of fire.

Where breakdown of components is involved, compliance is verified according to 12.3.1.

11.3 Limited power circuits

A limited power circuit is a circuit supplied by sources such as a battery or a transformer winding where the open-circuit potential is not more than a.c. 30 V r.m.s. and 42,4 V peak or d.c. 60 V, and the energy available to the circuit is limited according to one of the following means:

- the maximum output current and power are inherently limited to not more than the values of Table 45;
- the maximum output current under all conditions and power are limited by impedance to be not more than the values of Table 45;
- an over-current protective device limits the maximum output current and power to not more than the values of Table 46;
- a regulating network limits the maximum output current and power to not more than the values of Table 45 in normal use or as a result of one fault in the regulating network; or
- a regulating network limits the maximum output current and power to not more than the values of Table 45 in normal use, and an over-current protective device limits the output current and power to not more than the values of Table 46 as the result of any one fault in the regulating network.

Where an over-current protective device is used, it shall be a fuse or a non-adjustable non-self-resetting device.

Conformity is checked by measuring the output voltage, the maximum output current and the maximum available output power under the following conditions.

Output voltage is measured in no-load condition.

Output current and available power are measured after 60 s of operation, with any over-current protective devices short-circuited, with a resistive load (including short-circuit) which produces the highest value of current and power respectively.

Table 45 – Limits of output current and output power for inherently limited power sources

Open-circuit output voltage U		Maximum output current A	Maximum output power $V \times A$
AC V r.m.s.	DC V		
≤ 20	≤ 20	$\leq 8,0$	$\leq 5 \times U$
$20 < U \leq 30$	$20 < U \leq 30$	$\leq 8,0$	≤ 150
–	$30 < U \leq 60$	$\leq 150/U$	≤ 150

For non-sinusoidal a.c. and for d.c. with ripple exceeding 10 %, the peak voltage shall not exceed 42,4 V peak.

Table 46 – Limits of output current, output power and ratings for over-current protective devices for non-inherently limited power sources

Open-circuit output voltage U		Maximum output current A	Maximum output power $V \times A$	Rated current value of over-current protective device A
AC V r.m.s.	DC V			
≤ 20	≤ 20	$\leq 1\,000/U$	≤ 250	≤ 5
$20 < U \leq 30$	$20 < U \leq 60$	$\leq 1\,000/U$	≤ 250	$\leq 100/U$

Rated current values for over-current protective devices are for fuses and circuit-breakers which break the current within 120 s at a current value of 210 % of the value in the last column of the table.

11.4 Clearance and creepage distances requirements

Clearance and creepage distances shall be designed in accordance with this clause.

Creepage values are primarily directed at accommodating pollution concerns. Clearance values are primarily directed at accommodating overvoltage concerns.

Clearance and creepage distances between circuits shall meet the requirements associated with the higher of the voltages of the circuits.

There are no requirements for clearance and creepage distances for the inner layers of multi-layer printed-circuit boards.

The actual clearance and creepage distances requirements shall be based (1) on the working voltages for the circuit under evaluation and (2) on the pollution degree specified by the manufacturer.

The clearance and creepage distances within a particular circuit which serve only to permit the functioning of the device, and which do not serve to meet the requirements for galvanic isolation, need only be of a size to prevent faults from occurring which would lead to a risk of fire.

Linear interpolation of creepage distance is permissible. Interpolation of clearance is only permissible for a circuit or part that has no direct connection to the mains, but is powered from a transformer, converter, or equivalent isolation device. For voltage values less than or greater than those tabulated below, the tables in IEC 60664-1 may be used.

Components mounted to printed-circuit boards shall not degrade the galvanic isolation characteristics of the circuit under consideration. This determination shall be made in accordance with the requirements in Table 50, Table 51, Table 52, Table 53 and Table 54 or in accordance with the test requirements in Table 58 or Table 59.

For SELV/PELV circuits and ungrounded accessible parts, the requirements for double insulation shall apply to the clearance and creepage distances between these and hazardous live parts. Clearances and creepage distances within SELV/PELV circuits are based on functional needs and are not defined with respect to safety.

In all cases the values given shall be met or exceeded.

NOTE 1 The extent to which the manufacturing process can control the mechanical tolerance decides the limits to which practical clearance and creepage distances can approach the theoretical minimum values given in Table 47, Table 48, Table 49, Table 50, Table 52 and Table 53 and Table 54 of 11.4.

It is possible to approach minimum values when the equipment is manufactured in a factory under controlled conditions and finished to a point where additional assembly other than the connections to the field wiring terminals prior to placing the equipment in service is not necessary.

Replacement of components, normally affected in service shops or in normal use (for example, fuses), is considered to be part of controlled conditions.

Increased clearances are required when the equipment is field-mounted and field-connected because the method of mounting and the method of wiring at the field wiring terminals have to be considered.

Requirements of this subclause are verified in accordance with 12.1.8.

11.4.1 Clearances relating to overvoltage category II

11.4.1.1 Clearances for other than field-wiring terminals

Clearances associated with basic and supplementary insulation are given in Table 47 and clearances associated with double and reinforced insulation are given in Table 48.

Table 47 – Minimum clearances in air corresponding to overvoltage category II conditions (except for field wiring terminals) for basic/supplementary insulation

Working voltage U_e a.c. V r.m.s. or d.c. V	Minimum clearance mm		
	Pollution degree		
	1	2	3
50 (2)	0,04	0,2 (1)	0,8
100	0,1	0,2 (1)	0,8
150	0,5	0,5	0,8
300	1,5	1,5	1,5
600	3,0	3,0	3,0
1000	5,5	5,5	5,5

(1) For printed wiring material, the values for pollution degree 1 apply except that the value shall not be less than)
 (2) 0,04 mm.For d.c. products this range ends at 60 V.

NOTE Table derived from IEC 60664-1.

Table 48 – Minimum clearances in air corresponding to overvoltage category II conditions (except for field wiring terminals) for double /reinforced insulation

Working voltage U_e a.c. V r.m.s. or d.c. V	Minimum clearance mm		
	Pollution degree		
	1	2	3
50 (1)	0,1	0,2	0,8
100	0,5	0,5	0,8
150	1,5	1,5	1,5
300	3,0	3,0	3,0
600	5,5	5,5	5,5
1000	11	11	11

(1) For d.c. products this range ends at 60 V.

NOTE Table derived from IEC 60664-1.

Clearances shall be verified by mechanical measurement or by dielectric withstand tests according to 12.2.1 without pre-conditioning.

Clearances to walls of metal enclosures, which may be deflected, shall not be less than 12 mm.

The above clearances do not apply to printed circuit boards with protective coating complying with the test of 12.1.6.

The above clearances do not apply where overvoltages are known and controlled. Refer to 11.4.2 and Table 50.

11.4.1.2 Field-wiring terminal clearances

Minimum clearances at field-wiring terminals from terminal to terminal and from terminal to enclosure shall comply with the requirements of Table 49.

Table 49 – Minimum clearances in air at field-wiring terminals

Working voltage U_e AC V r.m.s. or d.c. V	Termination clearances mm		
	General use	Limited ratings (1), (2)	To walls of metallic enclosures which may be deflected
$0 < U_e \leq 50$	1,6	1,6	12
$50 < U_e \leq 300$	3,2	1,6	12
$300 < U_e \leq 600$	6,4	4,8	12

(1) Applicable to devices having ratings not more than 15 A at 51-150 V, 10 A at 151-300 volts, or 5 A at 301-600 V.
(2) Applicable to devices which control more than one load, provided that the total load connected at one time does not exceed 30 A at 51-150 V, 20 A at 151-300 V, or 10 A at 301-600 V.

11.4.2 Clearances for micro-environment where voltages are known and controlled

In the case where the peak voltages are known and controlled, the minimum clearances corresponding to these peak voltages are given in Table 50. Peak voltages are considered to be known and controlled, where the product design will limit the voltage to the appropriate value indicated in Table 50. This can be verified by examination or by demonstrating the voltage control at the circuit when subjected to the impulse voltage test Table 58.

**Table 50 – Minimum clearances in air for micro-environment
where the voltages are known and controlled**

Peak voltage including all transients and impulses V	Minimum clearances mm		
	Pollution degree		
Up to 2000 m altitude	1	2	3
330	0,01	0,20 (1)	0,80
500	0,04	0,20 (1)	0,80
800	0,1	0,2	0,80
1 500	0,5	0,5	0,80
2 500	1,5	1,5	1,5
4 000	3,0	3,0	3,0
6 000	5,5	5,5	5,5
8 000	8,0	8,0	8,0

(1) For printed circuit boards, the clearance for pollution degree 2 may be 0,04 mm for peak voltages of both 330 V and 500 V.

NOTE Table derived from IEC 60664-1.

Clearances shall be verified by mechanical measurement or by dielectric withstand tests according to 12.2.1 without pre-conditioning.

Clearances to walls of metal enclosures, which may be deflected, shall not be less than 12 mm.

11.4.3 Creepage distances for basic and supplementary insulation

A creepage distance cannot be less than the associated clearance so that the shortest creepage distance possible is equal to the required clearance. However, there is no physical relationship, other than this dimensional limitation, between the minimum clearance in air and the minimum acceptable creepage distance.

Creepage distances less than the clearances required in Table 47, Table 48 or Table 50 may only be used under conditions of pollution degrees 1 and 2 when an impulse withstand voltage test, according to Table 58 and Table 59, is also sufficient for the clearance distances.

This can occur when the circuit design uses a homogeneous field configuration which can achieve a greater impulse withstand voltage at the same clearance than an inhomogeneous field design.

NOTE See IEC 60664-1 for an explanation of homogeneous and inhomogeneous fields.

Insulating materials are separated into 4 groups by their comparative tracking index (CTI) values. The creepage distances are dependent on the CTI of the particular material specified in Table 51.

Table 51 – Classification of material group according to comparative tracking index (CTI)

CTI	Material group
$100 \leq \text{CTI} < 175$	IIIb
$175 \leq \text{CTI} < 400$	IIIa
$400 \leq \text{CTI} < 600$	II
$600 \leq \text{CTI}$	I

NOTE 1 Insulating material separation groups are according to IEC 60664-1.
NOTE 2 Comparative tracking index values are according to IEC 60112.

11.4.3.1 Minimum creepage distances (basic and supplementary insulation)**11.4.3.1.1 Minimum creepage distances for other than printed circuit boards**

Creepage distances shall be not less than values given in Table 52 nor less than the appropriate clearances.

Table 52 – Minimum creepage distances for other than printed circuit boards (1)

Working voltage U_e AC V r.m.s. or d.c. V (2)		Pollution degree 1	Creepage distances mm (3)					
			Pollution degree 2			Pollution degree 3		
		All material groups	Material group			Material group		
			I	II	IIIa, IIIb	I	II	IIIa, IIIb
Basic and supplementary insulation	50	0,18	0,6	0,85	1,2	1,5	1,7	1,9
	100	0,25	0,71	1,0	1,4	1,8	2,0	2,2
	125	0,28	0,75	1,05	1,5	1,9	2,1	2,4
	160	0,32	0,8	1,1	1,6	2,0	2,2	2,5
	250	0,56	1,25	1,8	2,5	3,2	3,6	4,0
	320	0,75	1,6	2,2	3,2	4,0	4,5	5,0
	630	1,8	3,2	4,5	6,3	8,0	9,0	10,0
1000	3,2	5,0	7,1	10,0	12,5	14,0	16,0 (4)	

(1) Creepage distances given in this table are for a.c. or d.c. voltages that contain no recurring peak voltages. For micro-environments where recurring peak voltages will be present, Table 54 applies.

(2) V r.m.s. of sinusoidal wave.

(3) Creepage (and clearance) distances between circuits shall be that corresponding to the highest working voltage and the corresponding dielectric withstand voltage.

(4) Only for material group IIIa. Material group IIIb is in general not recommended for application in pollution degree 3 above 630 V.

NOTE Table derived from IEC 60664-1.

11.4.3.1.2 Minimum creepage distances for printed circuit boards

Creepage distances associated with basic and supplementary insulation for protective coated and uncoated areas of printed circuit boards shall be not less than given in Table 53 nor less than the values of the appropriate clearances.

**Table 53 – Minimum creepage distances for printed circuit boards (1), (6), (9)
(basic and supplementary insulation)**

Working voltage U_e AC V r.m.s. or d.c. V (2)	Areas of PWBs with protective coating mm (3), (4), (5), (6)	Uncoated areas of PWBs mm	
		Pollution degree 1 (7)	Pollution degree 2 (8)
50	0,025	0,025	0,04
100	0,1	0,1	0,16
125	0,16	0,16	0,25
160	0,25	0,25	0,4
250	0,56	0,56	1,0
320	0,75	0,75	1,6
630	1,8	1,8	3,2
1000	3,2	3,2	5,0

(1) Creepage distances given in this table are for a.c. or d.c. voltages which contain no recurring peak voltage. For micro-environments where recurring peak voltages will be present, see Table 54.

(2) V r.m.s. of sinusoidal or non-sinusoidal wave.

(3) Protective coating shall adhere to the board insulation to result in a effectively solid insulation so as to exclude moisture and pollution and to withstand the specified overvoltages given in 11.1.4.

(4) Suitable for all material groups and pollution degrees 1, 2 and 3.

(5) No test is required if the manufacturer provides evidence that the protective coating has been tested according to either the test given in 12.1.6 or an equivalent acceptable independent laboratory test.

(6) A test board, coated but without components, shall withstand the appropriate dielectric test voltage given in 11.1.4.

(7) For all material groups.

(8) For material groups I, II, IIIa.

(9) Creepage (and clearance) distances between circuits shall be those corresponding to the highest working voltage and the corresponding dielectric withstand voltage.

NOTE Table derived from IEC 60664-1.

11.4.3.2 Creepage distance requirements for recurring peak voltages

11.4.3.2.1 Rationale

The phenomenon of partial discharges will occur on a surface that is subjected to long periods of high humidity and recurring peak voltages (impulses). These recurring peaks will dry out small areas between the conductors that will then flash over, giving rise to small sections of tracking. Eventually total tracking will occur between conductors and breakdown occurs. The values given in Table 54 will prevent any partial discharge from occurring, and are valid for pollution degrees 1 and 2.

11.4.3.2.2 Creepage distance requirements for recurring peak voltages

In addition to the clearance and creepage distance requirements of the preceding clauses, when recurring peak voltages are present the creepage distance requirements given in Table 54 below shall also be met.

Table 54 – Minimum creepage distances related to recurring peak voltages on printed wiring boards without protective coating (1) (pollution degrees 1 and 2)

Maximum recurring peak voltage (2),(3)	Creepage distance mm	Maximum recurring peak voltage (2),(3)	Creepage distance mm
330	0,1	1 150	1,6
400	0,2	1 250	1,8
450	0,25	1 650	3,0
600	0,4	1 700	3,2
640	0,5	2 200	5,0
800	0,75	2 300	5,5
1 140	1,5	2 800	8,0

(1) This table does not apply to peak values of 50 Hz/60 Hz wave of the mains supply. However, it does apply to short- duration peaks superimposed on the 50 Hz/60 Hz wave.

(2) Recurring peak voltage values are based on statistical evaluation of partial discharge data.

(3) Existence of recurring peak voltages may be determined by circuit analysis.

11.4.4 Creepage distances for double/reinforced insulation

Creepage distances shall be double the value for basic insulation.

11.4.5 Creepage for field-wiring terminals

Creepage distances for field wiring terminals shall be in accordance with Table 52, but not less than the clearance specified in Table 49.

11.5 Flame-retardant requirements for non-metallic materials

11.5.1 Non-metallic enclosure material

Non-metallic enclosure material which forms part of the ultimate enclosure shall have suitable flame-retardant properties to prevent or minimize the spread of flame and comply with a flame spread rating of 5VA, FV2, FV1 or FV0.

Flame spread ratings are given in Clause 9 of IEC 60707.

Non-metallic enclosure materials used for decorative purposes (for example, labels) or for functional purposes (for example, gaskets, keypad overlays) and which do not form an essential part of an enclosure require no special flame-retardant additive and no flame rating.

11.5.2 Non-metallic material supporting live parts

Non-metallic materials used to support live parts (such as printed circuit boards, transformer bobbins, battery housings, etc.), including insulating barriers, shall have suitable properties to prevent or minimize the spread of flame. Examples of these properties are: a flame rating of FV0, FV1 or FV2; a glow-wire test at 750 °C with a 30 s application and an extinguishing time less than, or equal to, 30 s according to IEC 60695-2-1; and a comparative tracking index greater than, or equal to, 175.

No tests are required if the PLC manufacturer provides evidence of compliance to the above referenced requirements or the equivalent. Non-metallic materials used in components (for example, transistors, integrated circuits, and capacitors) are excluded from the requirements of this clause.

11.5.3 Components

11.5.3.1 Non-metallic components

Non-metallic components not subject to the requirements of 11.5.1 or 11.5.2 shall be used in accordance with their specified ratings and are excluded from the requirements of 11.5.

11.5.3.2 Decorative and labelling materials

Decorative materials (cosmetic non-metallic materials) and labelling materials need not comply with 11.5.

11.5.3.3 Internal wiring or interconnection cables

Insulated wire used in unlimited circuits shall have a flammability classification of FV-1 or better according to IEC 60707 or an equivalent standard.

Wiring within limited power circuits has no flame-retardant requirements.

11.6 Temperature limits

Temperature limits are as follows.

Component temperature limits: Component parts and materials shall not be operated beyond their rated temperature limits or rated temperature rises.

Easily touched parts: Parts likely to be touched by an operator in normal use or by service personnel, as defined in Table 44, shall not exceed the temperature limits of Table 55.

Field wiring terminals shall be monitored for the temperature during the temperature test. This data is to be used in conjunction with the device rated ambient to determine the field-wiring insulation temperature rating.

Table 55 – Temperature limits

Absolute maximum temperatures	Access time	Metallic	Non-metallic	Examples
Operator hand-held equipment	Continuous	55 °C	70 °C	Hand-held terminals
Operator parts normally touched in operation	Momentary	70 °C	85 °C	Push-buttons on cabinet
Parts accessible during servicing, normally touched in operation	Momentary	70 °C	85 °C	Key switches on PLC
Parts accessible during servicing, not normally touched in operation	Momentary	100 °C (1)	100 °C (1)	Heatsinks

(1) A warning label is necessary if the temperature exceeds the level shown. See Clause 14.

11.7 Enclosures

Enclosures shall provide protection against the hazards of moving parts and contact with live parts.

Enclosures for equipment shall comply with the requirements of 11.7.1 or 11.7.2 as applicable.

11.7.1 Open equipment

Housings of open equipment are not considered to be an enclosure. The manufacturer's installation instructions shall specify how open equipment shall be installed so that it will meet the enclosure requirements of this standard.

11.7.2 Enclosed equipment

Enclosed equipment shall meet IP20 requirements as a minimum. This protection shall also be provided under all conditions of operator use.

11.7.2.1 Shafts and knobs

Conductive keypads, shafts and knobs external to the enclosure shall not be in contact with hazardous live parts. If the parts are normally held or actuated in normal use, the insulation provided shall be such that the shafts and knobs do not become live in the event of an insulation fault.

11.7.2.2 Mechanical strength

The mechanical strength of the enclosure shall be such as to withstand rough handling in normal use. The protection provided by the enclosures shall be verified after the application of the impact withstand test in 12.1.1 and the rigidity test in 12.1.7.

11.8 Field-wiring terminals constructional requirements

Terminals shall be so designed that loose strands of wire shall not reduce the required clearance/creepage requirements. This shall be verified in accordance with 12.1.9.

All parts of terminals that maintain contact and carry current shall be of metal of adequate mechanical strength. This shall be verified in accordance with IEC 60947-7-1.

Terminals shall be such that the conductors may be connected by means of screws, springs, or other equivalent means such as wire wrap, quick disconnect terminal, clamp-type connection so as to ensure that the necessary contact pressure is maintained over the full range of service conditions.

Terminals shall not allow the conductors to be displaced or be displaced themselves in a manner detrimental to the operation of the equipment and the clearance and creepage distances shall not be reduced below the required values.

The mechanical design of the interfaces shall allow that no individual conductor is subjected to bending of a radius of curvature less than 6 times its diameter after removal of the common elements (armour, sheaths, fillers).

Clearances between terminals and terminal to earthed parts are given in 11.4.1.2.

11.9 Provisions for protective earthing

The requirements specified below do not apply to SELV circuits where protective earthing is not required.

11.9.1 Protective earthing constructional requirements

The accessible parts of Class I equipment (for example, chassis, framework and fixed metal parts of metal enclosures) other than those which do not constitute a danger shall be electrically interconnected and connected to a protective earth terminal for connection to an external protective conductor. This requirement can be met by structural parts providing

adequate electrical continuity and applies whether the equipment is used on its own or incorporated in an assembly.

Cords or cables that supply power to Class 1 portable peripherals shall be provided with a protective earthing conductor.

Protective earthing conductor insulation, if provided, shall be green with a yellow stripe.

NOTE In North America the colour green is also acceptable.

Accessible isolated conductive parts are considered not to constitute a danger if they are so located as to exclude any contact with live parts and withstand the dielectric test voltage of Table 59 for reinforced insulation corresponding to the highest rated operational voltage of the unit.

Class II equipment may have an internal functional bonding conductor but shall not be provided with a protective earthing terminal or a protective earthing conductor in the mains power input cord.

11.9.2 Protective earthing terminal

If the PLC-system is provided with a protective earthing terminal (Class I equipment), the following requirements also apply in addition to the previous general connection specifications.

- The protective earthing terminal shall be readily accessible and so placed that the connection of the equipment to the protective earthing conductor is maintained when the cover or any removable part is removed.
- Products which are intended for cord connected use (such as peripherals) shall be provided with a protective earthing terminal integral to the plug cap or socket (if removable cord set).
- The protective earthing terminal shall be of screw, stud or pressure type and shall be made of a suitable corrosion resistant material.
- The clamping means of protective earthing terminals shall be adequately locked against accidental loosening, and it shall not be possible to loosen them without the aid of a tool.
- Protective earthing terminals and earthing contacts shall not be connected direct to the neutral terminal within the PLC-system. This does not prevent the connection of appropriately rated devices (such as capacitors or surge suppression devices) between the protective earthing terminal and neutral.
- The protective earthing terminal and subsequent protective equipment internal to the PLC-system shall comply with the test in 12.2.2.
- The protective earthing terminal shall have no other function.

11.10 Wiring

The following requirements shall apply to all wiring provided by the manufacturer for the internal and/or external wiring of PLC-system.

11.10.1 Internal wiring

The insulation, when provided, on all internal wiring of the equipment shall be rated for the voltage and the temperature conditions of use.

All splices and connections shall be mechanically secure and provide electrical continuity.

Internal wiring shall be so routed and secured that neither it nor related electrical connections are likely to be subjected to stress or mechanical damage. Internal wiring that is subject to flexing during operation or maintenance and whose conductors are solid or the insulation of which is less than 0,8 mm thick shall be tested for flexing integrity as specified in 12.1.4.

Electrical connections shall be soldered, welded, crimped, or otherwise securely connected.

Soldered connections subject to mechanical stress shall be mechanically secured independently from the soldering. Such connections shall not be used for other purposes such as fixing constructional parts.

Screw connections shall be secured against loosening.

This requirement does not apply to SELV/PELV circuits, earthing or bonding conductors.

11.10.2 Interconnection wiring

This clause applies to the PLC-system and the manufacturer supplied cables with connectors only and does not apply to the whole industrial control system in which the PLC-system is employed.

Cables and cords provided for the interconnection of equipment shall comply with the requirements of 11.10.1.

Cable assemblies and flexible cords provided for interconnection between sections of equipment or between units of a PLC-system shall be a type that is acceptable for the voltage and temperature involved and shall be provided with suitable strain relief.

Misalignment of plug and socket connectors, insertion of a multi-pin connector in a connector other than the one intended to receive it and plugging and unplugging of connectors that are accessible to the operator shall not result in mechanical damage or risk of fire to the PLC-system or electric shock or injury to persons from the PLC-system.

11.10.3 Mains power input cord

The mains power input cord provided by the manufacturer shall comply with the mains power input cord requirements in 6.10 of IEC 61010-1.

The circuitry connected to a cord set (removable or fixed) shall be so designed that there is no risk of electric shock, as indicated in 11.1, after 1 s when touching the pins of the plug and/or receptacle. Test shall be conducted in accordance with 12.2.3.

11.11 Switching devices

Switching devices shall be used within their ratings, according to IEC 60947-5-1, or equipment utilizing them shall be subjected to the overload and endurance tests specified in 12.2.4 and 12.2.5, respectively. The same sample shall be subjected first to the overload test and then the endurance test. The dielectric withstand test specified in 12.2.1 shall immediately follow the endurance test or the overload test when conducted alone.

The endurance test shall not be conducted on solid-state output devices for general or resistive use.

11.12 Components

Components shall comply with the applicable safety requirements of the relevant IEC product standard(s) or shall have been approved by a recognized testing authority for conformity with applicable safety requirements and need not be re-tested.

Where no relevant IEC component standard exists, or where components are used in circuits not in accordance with their specified ratings, the components shall be tested under the worst- case conditions occurring in the equipment.

NOTE Components are parts of PLC-system units; for example, capacitors, resistors, printed circuit boards, relays, transformers, switches.

11.13 Battery requirements

Battery cases or compartments shall be designed to protect against accumulation of flammable gases or damage from spilling of corrosive liquid as applicable.

Rechargeable and non-rechargeable batteries, if used in the PLC, shall be provided with suitable protection, internal or external to the battery cell, so as to minimize the risk of battery explosion. Parameters to be considered in the design should include temperature, possibility/ prevention of reverse current flow, limited discharge, etc.

Means shall be provided to prevent charging and to limit the discharge current of non-rechargeable batteries in both normal and single-fault conditions.

Compliance shall be verified by performance of the test in 12.3.1.

11.14 Maximum voltage and minimum voltage

The equipment shall operate as intended without an increased risk of fire or electric shock when subjected to maximum voltage or minimum voltage conditions. This requirement shall be verified by 12.1.5.

11.15 Markings and identification

Markings as indicated below shall be visible from the exterior of enclosed equipment, or be visible after removing a cover or opening a door without the aid of a tool, if the cover or door is intended to be removed or opened by an operator. For open equipment, markings are permitted to be on any surface that becomes visible after removal of the equipment from the rack or panel.

For all equipment, as a minimum, the information marked on the device shall identify the manufacturer (the company bringing the product to market) and the device. The remaining information shall be provided in the data sheet, supplied with the device.

The following information shall be provided by the manufacturer:

- manufacturer's name, trademark or other identification,
- model/catalogue number, type designation or name,
- hardware serial number or series and/or revision level (see 1.2), and date code or equivalent,
- information on replaceable fuses, including current, voltage and type,
- live parts (see 11.15.2) and protective earth terminals (see 11.15.3) markings shall be as required.

11.15.1 External wiring terminals identification

External wiring terminals shall be marked to indicate the proper connections for the power supply, load, control circuit, and the like, or a wiring diagram coded to the terminal marking shall be provided. A marking or manufacturer's installation instructions shall be provided to identify the temperature rating of field wiring to be connected to the wiring terminals.

11.15.2 Live parts

A live part exceeding SELV limits and likely to be mistaken as dead-metal (non-energized metal) and exposed to service personnel shall be marked with the following "dangerous voltage" symbol:



NOTE Symbol according to IEC 60417-5036.

11.15.3 Protective earth terminals markings

The protective earth terminal markings shall be durable and clearly identifiable.

The identification shall be achieved by the notation PE or by a graphical symbol for use on equipment or by the colour green-yellow.

NOTE 1 Notation PE according to 5.3 of IEC 60445.

NOTE 2 In North America the colour green only is also acceptable.

The graphical symbol to be used shall be:



NOTE Symbol according to IEC 60417-5019.

11.15.4 Equipment protected by double/reinforced insulation

Equipment protected throughout by double/reinforced insulation (Class II) shall be marked with the following symbol unless it is provided with a protective terminal.

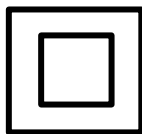

Equipment, which is only partially protected by double/reinforced insulation, shall not bear this symbol.

NOTE Symbol according to IEC 60417-5172.

11.15.5 Equipment supplied by SELV/PELV

Equipment intended to only be energized by a SELV or PELV source of supply shall be so marked on equipment and/or provided in product literature.

11.15.6 Rating information

Equipment shall be marked with the following as applicable:

- rated voltage(s) or range of voltage in volts (V);
- rated frequency in hertz (Hz);
- kind of supply system (a.c., d.c., or a.c./d.c. or the symbols 5032, 5031 or 5033 from IEC 60417);
- number of phase conductors if more than one;
- rated current in amperes (A); and/or
- rated input and/or output power in watts (W) or volt-amperes (VA).

For open-type equipment, the information shall be marked on the equipment or in the manual.

11.16 Requirements for safety type tests and verifications

Test and verifications for safety shall be performed by the manufacturer, in accordance with Clause 12.

11.17 Requirements for safety routine tests and verifications

Safety routine tests or an equivalent verification method (see specifically clause 13) shall be performed by the manufacturer, in accordance with 13.1 and 13.3.

11.17.1 Requirement for dielectric strength verification

Protection against electric shock shall be verified between (1) non-SELV circuits and SELV circuits, (2) non-SELV circuits and accessible conductive parts, and (3) isolated non-SELV circuits. This verification shall be performed by one of the following approaches.

Routine dielectric withstand testing of the product in accordance with 13.2.

Verification, during product development, that all of the relevant insulating materials and creepage and clearance distances of the product and that all isolating components meet one of the following:

- the component requirements of 11.12,
- 100 % dielectric withstand tested,
- verification by measurement to meet the required creepage and clearance distances.

11.17.2 Requirement for protective earthing verification

The manufacturer shall verify protective earthing continuity between the protective earthing interface/port and all operator accessible metal parts intended to be earthed, in accordance with the test described in 13.3.

11.18 Requirements for information on safety

Information on safety shall be provided by the manufacturer, in accordance with Clause 14.

12 Safety type tests and verifications

12.1 Safety-related mechanical tests and verifications

12.1.1 Impact withstand test

Table 56 – Impact withstand test (1)

Reference test	IEC 60950
Selection of sample(s)	Enclosed equipment with voltage greater than SELV/PELV
Exceptions	Test performed neither on hand-held equipment nor on displays nor lamps
Description of the test	See Figure 12
Number of trials	One per surface
Verification after the test	Perform the operator accessibility test (12.1.2 and 12.1.3) Perform the dielectric withstand test (12.2.1)

(1) The unit may be non-functioning before and after the test.

The impact is imparted to the sample by a solid, smooth steel sphere approximately 50 mm in diameter and with a mass of $500 \text{ g} \pm 25 \text{ g}$ (see Figure 12).

Top surface: The sphere is to fall freely from rest through a vertical distance of 1 300 mm to the top surface.

Vertical surfaces: The sphere is suspended by a cord and swings as a pendulum dropping through a vertical distance H of 1 300 mm to the sphere impact position.

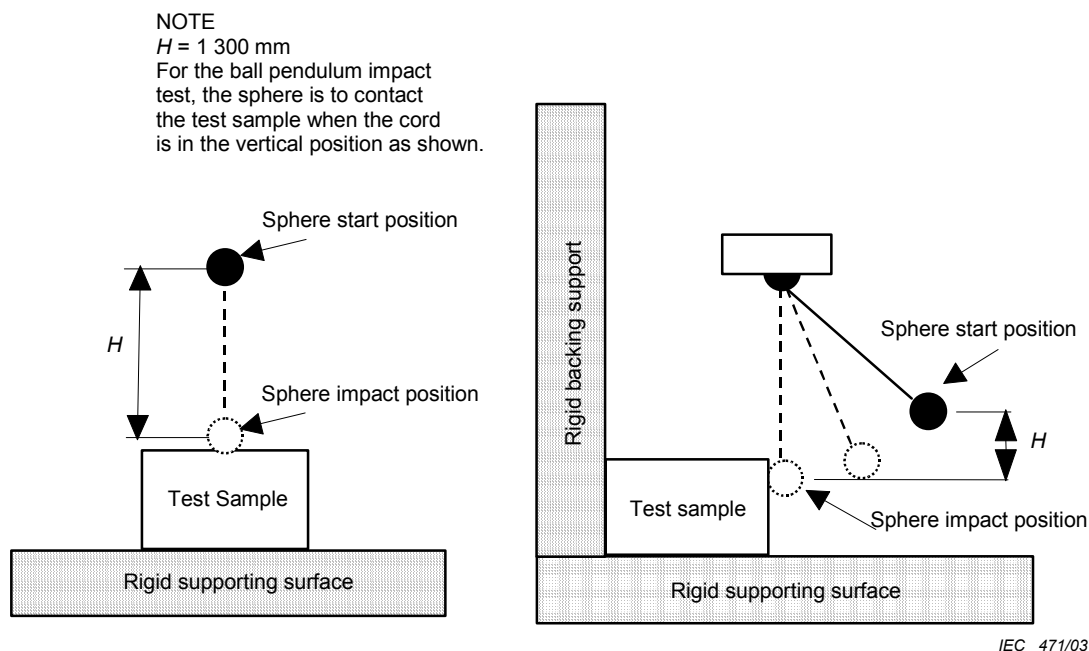

IEC 471/03

Figure 12 – Impact withstand test procedure

12.1.2 Operator accessibility tests

Table 57 – Operator accessibility tests (1)

Reference tests	IEC 60529
Selection of sample(s)	Enclosed equipment
Number of samples	One equipment of each type
Preconditioning	Clean and new
Details of mounting/support	According to manufacturer's specifications
Drain/ventilation holes	Configuration used in operating conditions
Moving parts test	Equipment energized and operating
Electrical shock test	Equipment de-energized
Test description	The jointed test finger (IP2X) and, where applicable, the test pin shall not make contact with any hazardous live part or any moving part (except smooth rotating shafts)
(1) For open equipment, no test is required, and the user is responsible for the safety of the equipment.	

Unless obvious, determination of whether a part is operator-accessible shall be made as specified in 12.1.3. The jointed test finger (Figure C.1) and test pin (Figure C.2) shall be applied without force unless a force is specified. Parts are considered to be accessible if they can be touched with a jointed test finger or test pin, or if they could be touched in the absence of any covering which is not considered to provide suitable insulation.

For equipment accepting plug-in modules, parts are not considered to be accessible if they cannot be touched with the jointed test finger (see 12.1.3) up to a depth of 180 mm from the opening in the equipment. Nor are they considered accessible if they are at a depth of more than 180 mm from the opening.

If the operator is intended to perform any actions in normal use (with or without a tool) which will increase the accessibility of parts, such actions shall be taken before performing the examinations of 12.1.3. Examples include removing covers, opening doors, adjusting controls, replacing consumable material, and removing parts.

12.1.3 General examination of openings

The jointed test finger (Figure C.1) shall be applied in every possible position. Where a part could become accessible by applying a force, the jointed test finger, made rigid, shall be applied with a force of 10 N. The force shall be exerted by the tip of the jointed test finger, made rigid, so as to avoid wedge and lever action. The test shall be applied to all outer surfaces, including the bottom.

The test pin (Figure C.3) shall be inserted in any openings above parts, which are hazardous live. The test pin shall be suspended freely and allowed to penetrate up to 100 mm. The additional safety measures of 11.1.7 for protection in single-fault condition are not required solely because a part is accessible by this test only.

The test pin (Figure C.4) shall be inserted through holes intended to give access to pre-set controls which require the use of a screwdriver or other tool. The test pin shall be applied in every possible direction through the hole. Penetration shall not exceed 3 times the distance from the enclosure surface to the control shaft or 100 mm, whichever is smaller.

12.1.4 Wire flexing test

The flexing test applies to wiring subject to flexing during operation or maintenance, and where conductors are solid or insulation is less than 0,8 mm thick.

Test procedure: The flexing test consists of flexing the wire/cable assembly between the 2 extreme points of travel for the cable.

Number of flexing cycles:

- 500, if flexing occurs under normal use;
- 25, if flexing occurs only during maintenance operations;

Pass/fail criteria:

The wiring shall be considered acceptable if, after this test, the insulation passes the application of the dielectric withstand test (12.2.1) and the following insulation breakdown test method).

Insulation breakdown test method:

The wiring being tested is removed from the equipment and the portion of the cable having been flexed is wrapped with a conductive foil. The applicable test voltage as given in Table 58 or Table 59 as appropriate is then applied between each conductor in turn and the common connection of all other conductors and this conducting foil.

12.1.5 Temperature test

Temperatures shall be measured while the equipment is generating its maximum dissipation. This dissipation may be caused by some combination of load current, input voltage, input frequency, I/O duty cycle, etc. The equipment shall be mounted in its normal-use position in a test ambient temperature equal to its maximum rated operating air temperature (see Table 2). However, the equipment may be at lower test ambient if the measured temperatures are increased by the difference between the equipment's maximum rated operating temperature and the actual test ambient. Steady-state conditions shall be achieved. The test ambient shall be monitored either at a point not more than 50 mm from the plane of the equipment's air flow entry point or at 1 point not more than 25 mm above and 1 point not more than 25 mm below the equipment with the ambient equal to the average of the 2 monitored temperatures. The environment surrounding the equipment under test shall not be subject to air movement caused by sources not part of the equipment under test.

Wiring should be the smallest size suitable for the maximum current rating of the equipment and manufacturer's instructions.

The temperature test shall be followed by the dielectric withstand test (12.2.1).

12.1.6 Protective coating test

The test shall be conducted in accordance with the Type A coating requirements in IEC 60664-3 or shall be approved by a recognized testing authority for conformity with applicable safety requirements.

12.1.7 Rigidity test

The equipment shall be held firmly against a rigid support and subjected to a force of 30 N applied by the hemispherical end of a hard rod of 12 mm diameter. The rod is applied to any part of the enclosure, which is accessible when the equipment is used, and which could cause a hazard if distorted. For equipment with a non-metallic enclosure, the test is performed at an ambient temperature of 40 °C.

Verification shall be in accordance with criteria 12.1.2 during and after the application of the force.

12.1.8 Clearance and creepage verification

Clearance and creepage requirements of 11.4 shall be verified by mechanical measurement where possible. Manufacturer's specifications (drawings, etc.) may be used in lieu of product samples.

12.1.9 Field-wiring terminals constructional verification

Terminals shall be designed to the requirements of 11.8. This shall be verified by fully inserting a stranded conductor with an 8 mm length of insulation removed with 1 of the strands free. The strand shall not touch parts of different polarity or accessible conductive parts, when bent in every possible direction without tearing back the insulation or making sharp bends around barriers.

12.2 Safety-related electrical tests

CAUTION:

It may be necessary to install an external impedance (a filter) to protect the test equipment that is connected to the basic PLC-system being tested.

12.2.1 Dielectric withstand verification test

Dielectric withstand testing is performed on an equipment sample preconditioned for 48 h at $40\text{ °C} \pm 2\text{ °C}$ and $92,5\% \text{ RH} \pm 2,5\% \text{ RH}$. The dielectric withstand testing must be performed within 1 h of the completion of the preconditioning.

Subclause 6.8.2 of IEC 61010-1 provides an alternate preconditioning method which may be utilized.

Preconditioning is not required for dielectric withstand testing following other tests.

One of the 3 test types – impulse, a.c., or d.c. – shall be performed at the test voltage specified in Table 58 or Table 59. The test voltage is based on the highest working voltage of the circuits involved. The choice of Table 58 or Table 59 is based on the insulation requirement specified in 11.1.

Test characteristics:

Impulse test, according to IEC 60060-1 and the following conditions:

Waveshape:	1,2/50 μs
Source impedance:	500 $\Omega \pm 10\%$
Source energy:	0,5 J $\pm 20\%$
Length of connection:	$\leq 2\text{ m}$
Time between two impulses:	$\geq 5\text{ s}$

AC voltage test

Test time:	1 min
Voltage signal:	starting from 0 V (zero crossing)
Short-circuit current:	$\leq 5\text{ mA}$

DC voltage test

Test time:	1 min
Short-circuit current:	$\leq 5\text{ mA}$

NOTE In general, preference should be given to the impulse test; however, where filter capacitors are used (line-to-earth), the d.c. test is recommended.

The dielectric test voltage is applied between

- a) isolated non-SELV circuits,
- b) isolated non-SELV circuits and SELV circuits, and
- c) isolated non-SELV circuits and accessible conductive parts.

The tests are carried out on each unit and module connected in the test circuit as shown in Figure 13. If required, tests can be carried out on individual modules with the remaining modules removed. All mechanical switches shall be in the "on" closed position. Any accessible insulating part of an enclosure shall be covered with metal foil and the foil considered an accessible conductive part.

There shall be no unintentional flashover or breakdown of the insulation during the test (an intentional flashover is one which might be the result of the normal action of a surge suppression device incorporated in the equipment). Eventual operation of protecting devices provided on the units shall not be considered as a failure.

Dielectric withstand testing need not be performed between

- a) SELV/PELV circuits and accessible parts, or
- b) SELV circuits and other SELV circuits.

Exceptions:

These tests need not be done on units (parts of the basic PLC-system) which have been tested separately according to the relevant standards, provided

- the values given in Table 58 or Table 59 have been met, and
- their dielectric strength is not impaired by assembly.

Table 58 – Dielectric withstand voltages for impulse a.c. power-frequency and d.c. tests for basic/supplementary insulation (5)

Working voltage of circuit (1) AC V r.m.s. or d.c. V	Test voltages for 0-2000 m		
	V		
For basic and supplementary Insulation	1,2/50 μ s Impulse peak (2)	AC 1 min	DC 1 min
$0 < U_e \leq 50$ (3)	500	350	500
$50 < U_e \leq 100$ (4)	800	490	700
$100 < U_e \leq 150$	1 500	820	1 150
$150 < U_e \leq 300$	2 500	1 350	1 900
$300 < U_e \leq 600$	4 000	2 200	3 100
$600 < U_e \leq 1 000$	6 000	3 250	4 600

(1) Working voltage at the field wiring terminals of the device or circuit.
(2) Three positive and 3 negative impulses at least 1 s between each.
(3) For d.c. products this range ends at 60 V.
(4) For d.c. products this range begins at 60 V.
(5) No test is needed for SELV/PELV circuits/units.

Table 59 – Dielectric withstand voltages for impulse a.c. power frequency and d.c. tests for double/reinforced insulation (5)

Working voltage of circuit (1) AC V r.m.s. or d.c. V	Test voltages for 0-2000 m V			
	For double/reinforced insulation	1,2/50 μ s Impulse peak (2)	AC 1 min	DC 1 min
$0 < U_e \leq 50$ (3)		850	510	720
$50 < U_e \leq 100$ (4)		1 360	740	1 050
$100 < U_e \leq 150$		2 550	1 400	1 950
$150 < U_e \leq 300$		4 250	2 300	3 250
$300 < U_e \leq 600$		6 800	3 700	5 250
$600 < U_e \leq 1 000$		10 200	5 550	7 850

(1) Working voltage at the field wiring terminals of the device or circuit.
 (2) Three positive and 3 negative impulses at least 1 s between each.
 (3) For d.c. products this range ends at 60 V.
 (4) For d.c. products this range begins at 60 V.
 (5) No test is needed for SELV/PELV circuits/units.

Text deleted

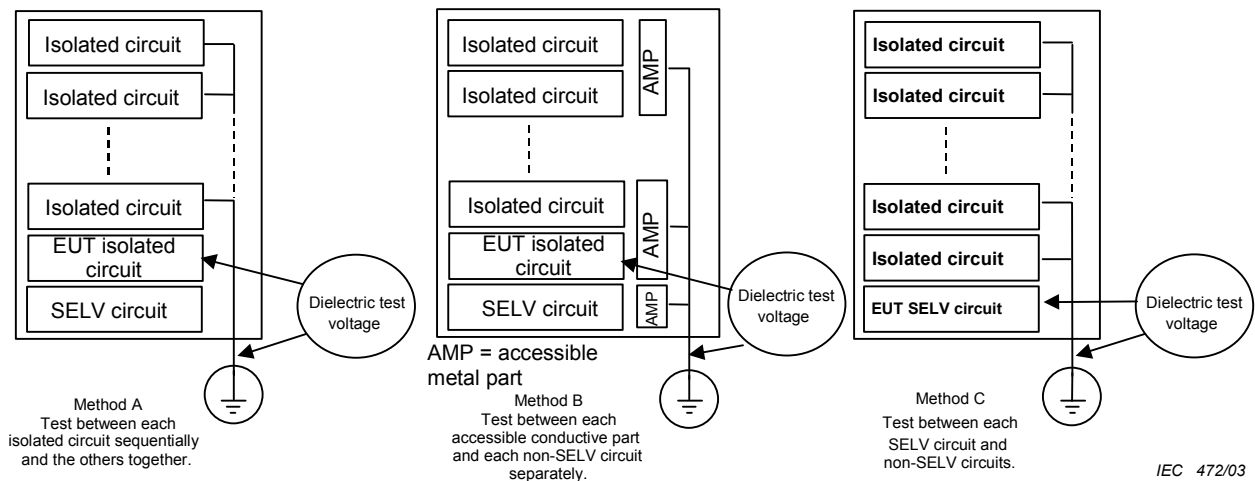

Figure 13 – Dielectric withstand test procedures

12.2.2 Protective earthing continuity test

Test description: A constant current of 30 A for at least 2 min shall be injected between the earthing terminal or contact and each of the accessible metal parts intended to be earthed. The current shall be maintained or adjusted accordingly during the test to 30 A. Any convenient low voltage not exceeding 12 V can be used. The voltage drop shall be measured between the points of current flow, care being taken that the contact resistance between the tip of the measuring probe and the metal part underneath does not influence the test results.

Pass/fail criteria: The calculated resistance shall not exceed 0,1 Ω .

12.2.3 Stored energy injury risk test

Equipment shall be so designed that at an external point of disconnection of the mains supply, there is no risk of electric shock from stored charge on capacitors connected to the mains circuit.

Compliance is checked by inspection of the equipment and relevant circuit diagrams, taking into account the possibility of disconnection of the supply with the on/off switch in either position (if present).

Equipment shall be considered to comply if any capacitor having a rated capacitance exceeding $0,1 \mu\text{F}$ and connected to the external mains circuit, has a means of discharge resulting in a time constant not exceeding

- 1 s for pluggable equipment,
- 10 s for permanently connected equipment.

The relevant time constant is the product of the effective capacitance in microfarads and the effective discharge resistance in megohms. Where it is difficult to determine the effective capacitance and resistance values, a measurement of voltage decay may be used. In 1 time constant the voltage will have decayed to 37 % of its original value.

12.2.4 Overload test

Switching devices shall close and open a test circuit having the current, voltage, and power factor values given in Table 60. Fifty cycles, each consisting of 1 closed and 1 open action, shall be completed using a timing of 1 s on, 9 s off. After completion of the 50 cycles, the equipment shall be subjected to the endurance test in 12.2.5, if required by 11.11.

Table 60 – Overload test circuit values

Intended use	Current	Voltage	Power factor
AC general use	$1,5 \times \text{rated}$	Rated	0,75 to 0,80
DC general use	$1,5 \times \text{rated}$	Rated	1,0
AC resistance	$1,5 \times \text{rated}$	Rated	1,0
Pilot duty	Rated (1)	$1,1 \times \text{rated}$ (2)	<0,35

(1) Unless otherwise specified, the inrush current shall be 10 times the steady-state current.
(2) Set up the EUT at its rated voltage and current and then increase the voltage by 10 % without further adjustment of the load.

Pass/fail is determined by test completion without electrical/dielectric/mechanical breakdown of the equipment.

12.2.5 Endurance test

After completion of the overload test in 12.2.4, the switching device is to close and open a test circuit having the current, voltage, and power factor values given in Table 61. A total of 6 000 cycles, consisting of 1 closing and 1 opening, shall be completed. The cycle timing shall be 1 s on and 9 s off, except for the first 1 000 cycles of the pilot duty test. The first 1 000 cycles of the pilot duty test shall be at a rate of 1 cycle per second except that the first 10 to 12 cycles are to be as fast as possible.

The endurance test need not be conducted on solid-state output devices for general or resistive use.

Table 61 – Endurance test circuit values

Intended use	Current	Voltage	Power factor
AC general use	Rated	Rated	0,75 to 0,80
DC general use	Rated	Rated	1,0
AC resistance	Rated	Rated	1,0
Pilot duty (1)	Rated	Rated	<0,35

(1) The test circuit is identical to the overload test circuit except that the voltage is the rated voltage.

Pass/fail is determined by test completion without electrical/dielectric/mechanical breakdown of the equipment.

12.3 Single-fault condition test – General

Equipment and its circuit diagram shall be examined to determine fault conditions that are liable to result in hazards. These fault conditions shall be applied while the equipment is operating under least favourable normal condition. Some of the specific single-fault condition tests are covered in 12.3.1, 12.3.2, and 12.3.3.

The equipment shall be operated until further change as a result from the applied fault is unlikely. This is normally limited to 1 h. If at the end of 1 h there is an indication that there is a risk of spread of fire, electric shock or injury to persons, the test shall be continued until 1 of these hazards does occur or for a maximum period of 4 h.

For open equipment, a wire mesh cage that is 1,5 times the size of the device may be provided to simulate the intended enclosure. The outer enclosure or wire mesh cage (if any) and any grounded or exposed dead-metal parts are to be connected through a 3 A fast-acting (non-time delay) fuse to the supply circuit pole least likely to arc to ground.

The fault conditions shall be applied only 1 at a time in any convenient order. Multiple simultaneous faults shall not be applied.

After application of each fault condition, there shall be

- a) no emission of flame or molten material nor ignition of cotton loosely placed around the item under test,
- b) no accessible hazardous live parts, and
- c) no opening of the 3 A fuse.

12.3.1 Single-fault condition – Breakdown of components test

Individual components, such as capacitors, diodes or other solid-state components, shall be short- or open-circuited.

Exception: The test is not required

- if circuit analysis indicates that no other component or portion of the circuit will be seriously overloaded as a result of the assumed open-circuiting or short-circuiting of another component;
- for components whose failure may result in increased risk of fire or electric shock and that have previously been investigated and found suitable for the application.

12.3.2 Single-fault condition – Protective impedance test

If a protective impedance is formed by combination of components, each component shall be short-circuited or open-circuited, whichever is less favourable.

If a protective impedance is formed by the combination of basic insulation and a current- or voltage-limiting device, both the basic insulation and the current- or voltage-limiting device shall be subjected to single faults, applied 1 at a time. Basic insulation shall be short-circuited and the current- or voltage-limiting device shall be short-circuited or open-circuited, whichever is less favourable.

12.3.3 Single-fault condition – Mains transformers test

The secondary windings of mains transformers shall be short-circuited, 1 winding at a time.

Current limiting impedances or overcurrent protection devices, which are directly connected to any secondary winding, shall be connected during this test.

13 Safety routine tests

13.1 Dielectric withstand test

Safety of insulation and/or barriers is established according to the requirements of Clause 11. Manufactured quality of the insulation and/or barriers must also be established according to one of the following methods.

1) Routine dielectric withstand testing of the product in accordance with 13.2.

When this method is chosen, the tests of 13.2 shall only be performed on equipment that has operator-accessible hazardous live parts.

Unless it can be shown that subsequent manufacturing cannot invalidate the results of these tests, these tests shall be performed on fully assembled modules or equipment.

2) Verification that all isolating components used in the production of modules or equipment are 100 % dielectric withstand tested as components or are supplied as meeting the component requirements of 11.12.

When this method is chosen, it must be used in conjunction with

- verification by type tests that dielectric strength requirements of 11.1.4 are met;
- verification that creepage and clearance distances of 11.4 are met by the product during design;
- automated assembly and quality controlled manufacturing processes that assure consistency of the manufactured product.

13.2 Dielectric withstand verification test

The test voltage specified in Table 62 shall be applied between hazardous live terminals and circuits, and all accessible conductive parts including terminals intended to be connected to circuits of other equipment which are not hazardous live but which are accessible. One of the tests in Table 62 shall be carried out.

Table 62 – Routine dielectric withstand test (5)

Working voltage of circuit (1) AC V r.m.s. or d.c. V	Test voltages for 0-2000 m		
	V		
	1,2/50 μ s impulse peak (2)	AC 2 s	DC 2 s
$U_e \leq 30$	No test required	No test required	No test required
$30 < U_e \leq 50$ (3)	500	350	500
$50 < U_e \leq 100$ (4)	800	490	700
$100 < U_e \leq 150$	1 500	820	1 150
$150 < U_e \leq 300$	2 500	1 350	1 900
$300 < U_e \leq 600$	4 000	2 200	3 100
$600 < U_e \leq 1000$	6 000	3 250	4 600

(1) Working voltage at all the operator-accessible terminals of the device or circuit.

(2) Three positive and 3 negative impulses at least 1 s between each.

(3) For d.c. products this range ends at 60 V.

(4) For d.c. products this range begins at 60 V.

(5) No test is needed for SELV/PELV circuits/units.

13.3 Protective earthing test

A simple continuity test shall be made between the protective earthing interface/port and all operator-accessible metal parts, intended to be earthed. The test shall be performed on all non-SELV/PELV rated voltage units.

The resistance shall not exceed 0,1 Ω .

14 Safety information to be provided by the manufacturer

The manufacturer's data shall include the following information as a minimum.

Protective earthing requirements and recommendations concerning personnel safety circuits.

Requirements for the maintenance of protective devices, such as protective earthing circuits, overcurrent protective devices, and batteries utilized for memory back-up, etc.

If the PLC-system is provided as "open equipment", a suitable enclosure is required to provide the necessary level of safety and environmental protection and guidelines for mounting, spacing, and/or internal barriers or shields if needed for safety.

Precautionary instructions, if removal of any module while the equipment is in operation can affect safety related to electrical shock, fire hazard and electrical damage.

A statement of the intended use of the PLC-system relative to overvoltage category as defined in 3.43.

Isolation potentials between channel and other circuits (including ground) and between channels under normal condition.

Information to be made available can be in other than printed form.

14.1 Information on evaluation of enclosures for open equipment (power dissipation)

The manufacturer's documents shall provide information to allow the evaluation of the power dissipation of every PLC configuration, subassembly and module and provide information regarding minimum spacing required to assure adequate cooling under normal service conditions.

14.2 Information on mechanical terminal connection

The manufacturer shall provide the following information through convenient documentation and/or marking.

Type, cross-sectional area and material of the conductors that may be connected to the PLC-system.

Recommendations for use of shielded cables, and how they are to be connected and earthed.

Annex A
(informative)

Illustration of PLC-system hardware definitions

Figure A.1 illustrates the hardware in the PLC-system as defined for the purposes of IEC 61131-1 and IEC 61131-2.

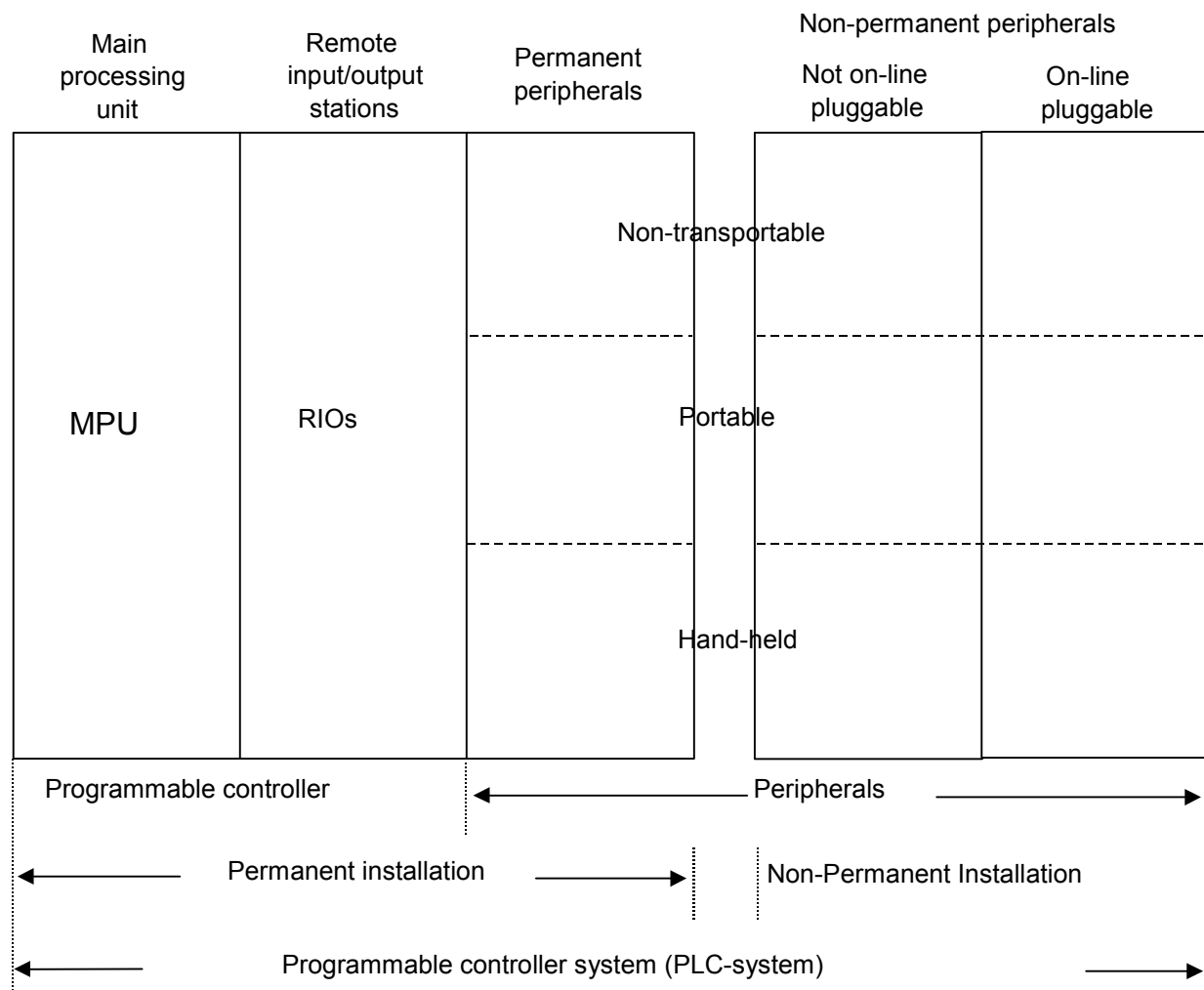

IEC 473/03

Figure A.1 – Programmable controller system (PLC-system)

Portable and hand-held peripherals have specific requirements and have to be distinguished from permanently installed peripherals (see 4.2.3).

Annex B (informative)

Digital input standard operating range equations

The following equations were used to generate Table 7 (with some exceptions explained in the notes).

DC equations

$$U_{H \max} = 1,25 U_e$$

$$U_{H \min} = 0,8 U_n - U_d - 1V$$

$$U_{T \max} = U_{H \min}$$

$$U_{L \max} = U_{H \min} \text{ for } I \leq I_{T \min}$$

$$U_{T \min} = 0,2 U_n$$

$$U_{L \max} = U_{T \min} \text{ for } I > I_{T \min}$$

$$U_{L \min} = -3 \text{ V (DC 24 V)}$$

$$U_{L \min} = -6 \text{ V (DC 48 V)}$$

$$I_{L \min} = \text{ND (Not defined)}$$

Type 1 inputs:

$$I_{H \max} = I_{T \max} = I_{L \max} = 15 \text{ mA}$$

$$I_{H \min} \approx I_{T \min} + 1 \text{ mA}$$

$$I_{T \min} \approx U_{H \max}/Z$$

$$U_d = 3 \text{ V (Table 9)}$$

Type 2 inputs:

$$I_{H \max} = I_{T \max} = I_{L \max} = 30 \text{ mA}$$

$$I_{H \min} = I_m + 1 \text{ mA} = 6 \text{ mA}$$

$$I_{T \min} = I_r = 1,5 \text{ mA}$$

$$U_d = \text{d.c. } 8 \text{ V}$$

Type 3 inputs:

$$I_{H \max} = I_{T \max} = I_{L \max} = 15 \text{ mA}$$

$$U_{H \max}/Z \leq I_{H \min} \leq I_m = 5 \text{ mA}$$

$$I_{T \min} = I_r = 1,5 \text{ mA}$$

$$U_d = \text{d.c. } 8 \text{ V}$$

AC equations

$$U_{H \max} = 1,1 U_e$$

$$U_{H \min} = 0,85 U_n - U_d - 1V \quad (1,2)$$

$$U_{T \max} = U_{H \min}$$

$$U_{L \max} = U_{H \min} \text{ for } I \leq I_{T \min}$$

$$U_{T \min} = 0,2 U_n \quad (1)$$

$$U_{L \max} = U_{T \min} \text{ for } I > I_{T \min}$$

$$U_{L \min} = 0$$

$$I_{L \min} = 0$$

Type 1 inputs:

$$I_{H \max} = I_{T \max} = I_{L \max} = 15 \text{ mA}$$

$$I_{H \min} \approx I_{T \min} + 1 \text{ mA } (U_e \leq 120 \text{ V r.m.s.}) \text{ or}$$

$$I_{H \min} \approx I_{T \min} + 2 \text{ mA } (U_e > 120 \text{ V r.m.s.})$$

$$I_{T \min} \approx U_{H \max}/Z \quad (5)$$

$$U_d = 5 \text{ V (Table 8)} \quad (3)$$

Type 2 inputs:

$$I_{H \max} = I_{T \max} = I_{L \max} = 30 \text{ mA}$$

$$I_{H \min} \approx I_m + 1 \text{ mA} = 6 \text{ mA}$$

$$I_{T \min} \approx I_r = 3 \text{ mA} \quad (4)$$

$$U_d = \text{a.c. } 10 \text{ V r.m.s.} \quad (4)$$

Type 3 inputs:

$$I_{H \max} = I_{T \max} = I_{L \max} = 15 \text{ mA}$$

$$I_{H \min} = I_m = 5 \text{ mA}$$

$$I_{T \min} \approx I_r = 3 \text{ mA} \quad (4)$$

$$U_d = \text{a.c. } 10 \text{ V r.m.s.} \quad (4)$$

NOTE 1 For all a.c. 100/110/120 V r.m.s. and all a.c. 200/220/230/240 V r.m.s. inputs, U_n has been respectively selected as a.c. 100 V r.m.s. and a.c. 200 V r.m.s., in order to allow compatibility of a single module with various supply voltages.

NOTE 2 1 V drop (a.c. or d.c.) is assumed for the connecting leads.

NOTE 3 Maximum values of voltage drops, U_d , of digital outputs for d.c. and a.c.

NOTE 4 These values of I_r , U_d and I_m correspond to those adopted in IEC 60947-5-2.

NOTE 5 Z = Empirical worst-case relay contact, open-contact impedance = 100 k Ω .

Annex C (normative)

Test tools

C.1 Jointed test finger

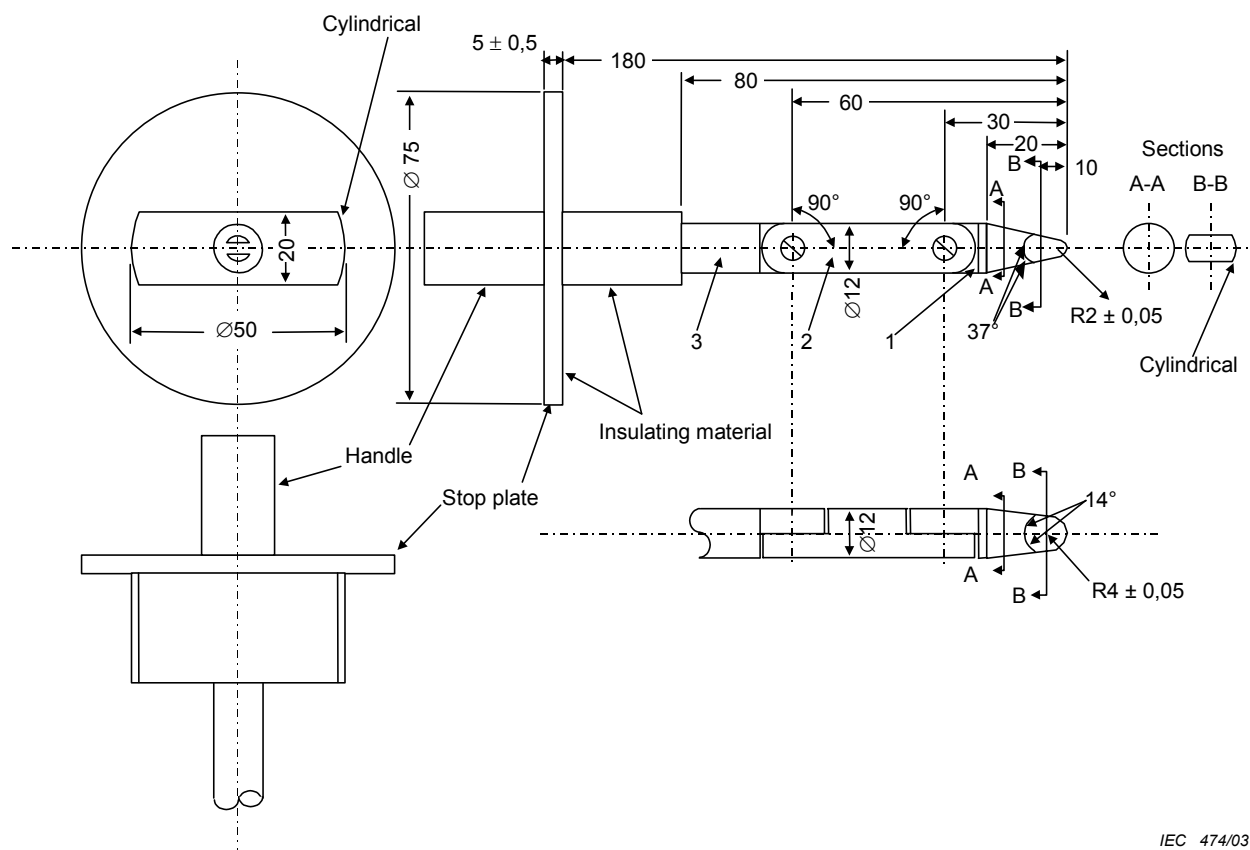

IEC 474/03
Dimensions in millimeters

Figure C.1 – Jointed test finger

Tolerances on dimensions without specific tolerance

- on angles: $+0'$, $-10'$
- on linear dimensions: up to 25 mm, $+0$, $-0,05$ mm
- on linear dimensions: over 25 mm: $\pm 0,2$ mm

Material of finger shall be heat-treated steel and suitable insulator.

Both joints of the finger may be bent through an angle of $90^\circ + 10^\circ$, -0° , but in one and the same direction only.

C.2 Test pins

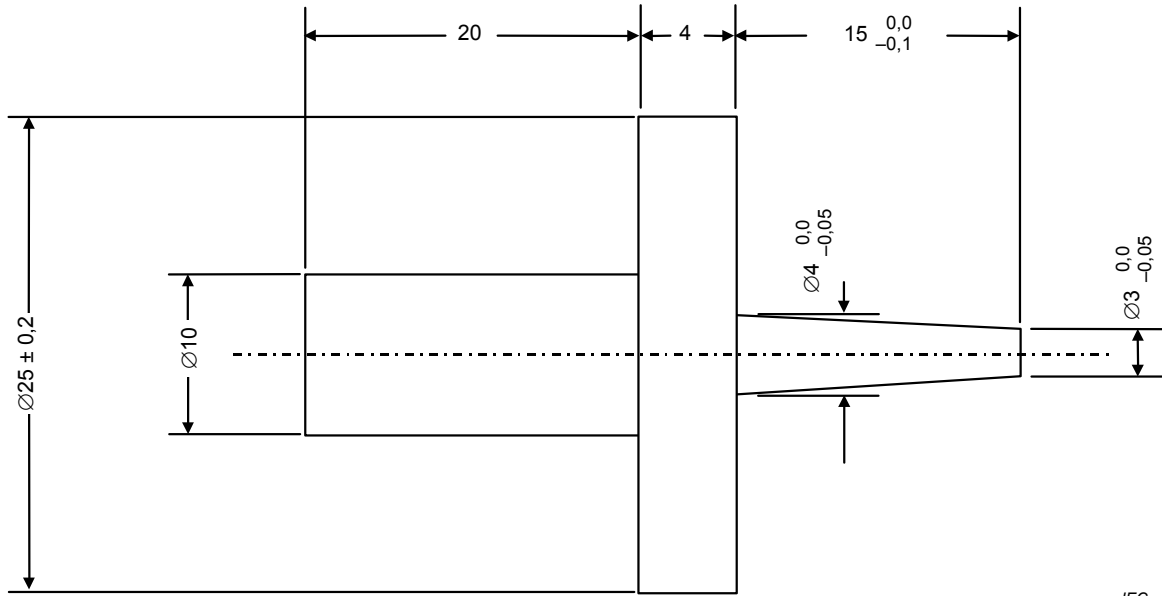

IEC 475/03

Dimensions in millimeters

Figure C.2 – 15 mm x 3 mm test pin

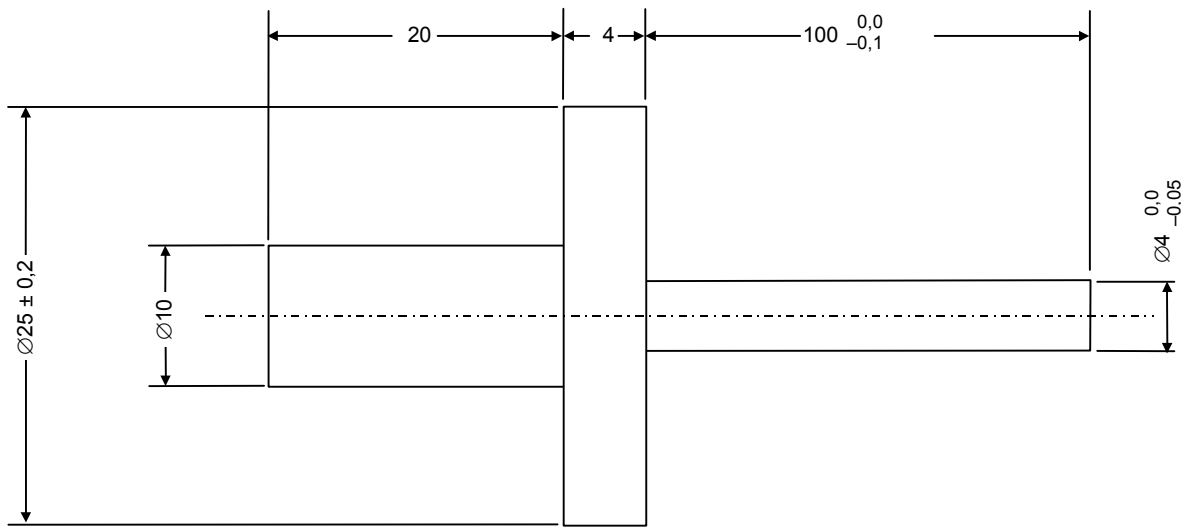

IEC 476/03

Dimensions in millimeters

Figure C.3 – 100 mm x 4 mm test pin

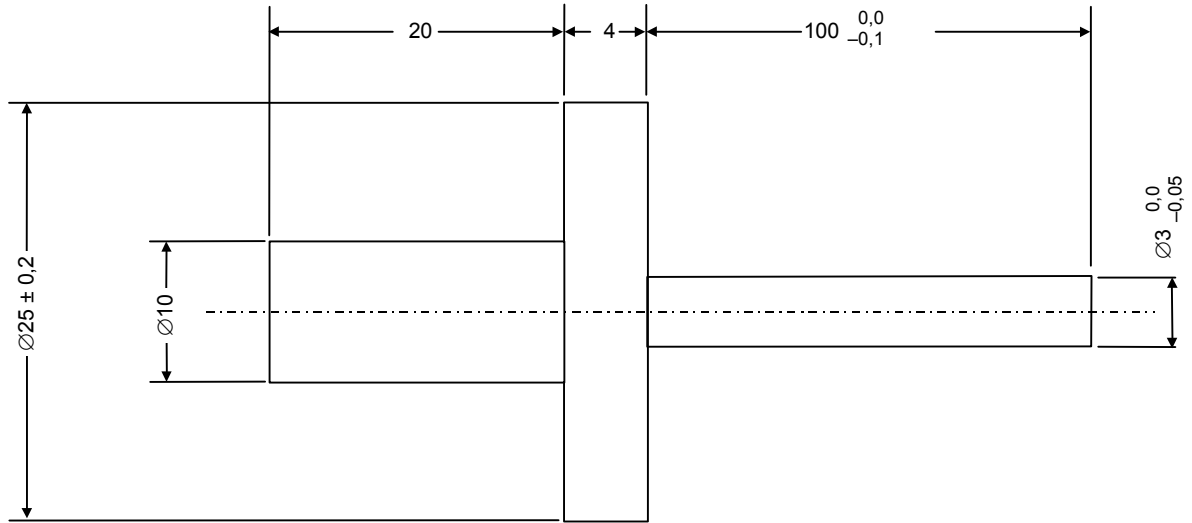

IEC 477/03
Dimensions in millimeters

Figure C.4 – 100 mm × 3 mm test pin

Annex D (informative)

Zone C – EMC immunity levels

When higher interference levels are encountered than zone B, the following levels, associated with Zone C, may be appropriate.

Table D.1 – Radiated immunity and enclosure ports (1) conducted immunity, Zone C

Environmental phenomenon	Basic standard	Units	Test severity	Test set-up	Normative items	Performance criteria
Electrostatic discharge	IEC 61000-4-2	kV	± 4 Contact ± 8 Air	Table 36	(1)	B B
Radiofrequency electromagnetic field amplitude-modulated	IEC 61000-4-3	GHz MHz MHz V/m % AM, 1 kHz Sinusoidal	1,4-2,0 800-960 80-1 000 10 80	Table 37	(4)	A
Power-frequency magnetic fields	IEC 61000-4-8	Hz	60	Table 38	(2), (3)	A
		A/m	30			
		Hz	50	Table 38	(2), (3)	A
		A/m	30			

(1) The ESD test shall be applied to (1) operator-accessible devices (for example, HMI, PADT and TE) (2) enclosure ports, (3) service accessible parts (for example, switches, keyboards, protective/functional earth, module packaging, communications ports with connectors in place and metal connectors) which are not protected from casual access. The ESD test shall not be applied to communications ports without connectors in place, I/O ports or power ports.

(2) This test is meant to test equipment sensitivity to magnetic fields normally occurring on the factory floor. The test is only applicable to equipment containing devices susceptible to magnetic fields, such as Hall-effect devices, CRT displays, disk drives, magnetic memories and similar equipment. The PLC-system does not normally contain such devices; however, other devices, such as HMI, may. The test is not meant to duplicate high-intensity magnetic fields such as those, for example, associated with welding and induction heating processes.

(3) There will be no deviation up to 3 A/m. Above 3 A/m the manufacturer will specify the allowed deviation for CRT display interfaces.

(4) This level does not represent the field emitted by a transceiver in close proximity to the PLC-system.

Table D.2 – Conducted immunity, Zone C

	Environmental phenomenon	Fast transient burst	High energy surge	Radio-frequency interference	Damped oscillatory wave
	Basic standard	IEC 61000-4-4	IEC 61000-4-5	IEC 61000-4-6	IEC 61000-4-12
	Test set-up	Table 39	Table 40	Table 41	Table 42
	Performance criteria	B	B	A	B
	Normative Items		(1), (2)		(1)
Interface/Port Figure 2 (designation)	Specific interface/port				
Data communication (AI and Ar for I/O racks and Be, Bi and E for peripherals)	Communication	–	–	–	–
	Shielded cable	1 kV (5)	2 kV CM	10V (5)	0,5 kV CM
	Unshielded cable	1 kV (5)	No test	10 V (5)	No test
		–	–	–	–
Digital and analogue I/Os (C & D)	AC I/O (unshielded)	2 kV (5)	2 kV CM 1 kV DM	10 V (5)	2,5 kV CM 1 kV DM
	Analogue or DC I/O (unshielded)	2 kV (5)	1 kV CM 0,5 kV DM	10 V (5)	1 kV CM 0,5 kV DM
	All shielded lines (to shield)	2 kV (5)	2 kV CM	10 V (5)	0,5 kV CM
Mains power (F)	AC power	4 kV	4 kV CM 2 kV DM	10 V	2,5 kV CM 1 kV DM
	DC power	2 kV (4)	2 kV CM 1 kV DM	10 V	2,5 kV CM 1 kV DM
Protective earthing (G)	Protective earth	No test	No test	No test	No test
Functional earthing (H) (3)	Functional earth	2 kV (5)	No test	10 V	No test
I/O power (J) and auxiliary power output (K)	I/O and a.c. auxiliary power	2 kV	2 kV CM 1 kV DM	10 V	2,5 kV CM 1 kV DM
	I/O and d.c. auxiliary power	2 kV (4)	1 kV CM 0,5 kV DM	10 V	1 kV CM 0,5 kV DM
<p>(1) Not applicable to d.c. power ports intended for connection to a battery or a rechargeable battery that must be removed or disconnected from the equipment for recharging. The test is applicable to d.c. power ports, unless cables are specified ≤ 10 m a.c. Power ports to be tested regardless of specified length.</p> <p>(2) For non-mains power ports with cables specified ≤ 30 m, no test is needed.</p> <p>(3) If this port is used for shield returns, this port would be tested as a consequence of the shielded cable test. Otherwise, no specific test of this port is required.</p> <p>(4) For ports with cables specified ≤ 10m, no test is needed.</p> <p>(5) For ports with cables specified ≤ 3m, no test is needed.</p>					

The requirements of this subclause are verified in accordance with 9.5, 9.6, 9.7, 9.8, 9.9, 9.10 and 9.11.

Annex E (informative)

Overvoltage example

Figure E.1 shows which requirements apply to each part of a typical design of a power supply. The following assumptions are made in this example: overvoltage category II, pollution degree 2, material group II, no overvoltage protection, all values are interpolated for 230 V r.m.s. unless otherwise noted.

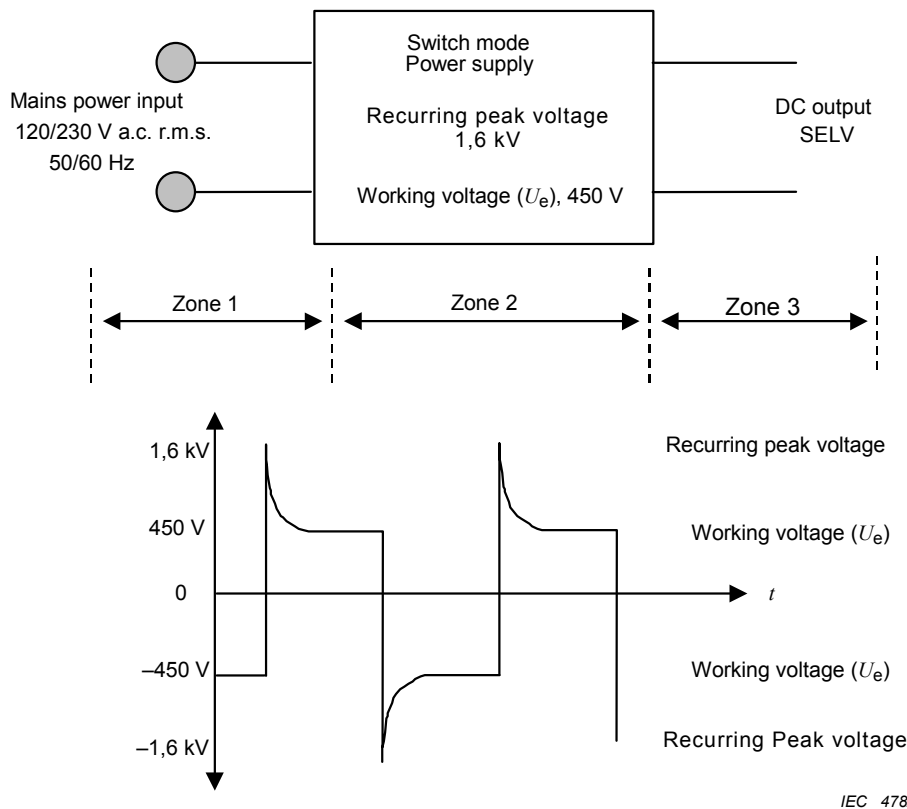

Figure E.1 – Creepage distances of circuits where recurring peak voltages are generated

Zone 1: At the field wiring terminals the 1,6 mm interpolated from Table 49 dominates the 1,98 mm creepage distance from Table 52. Therefore, a minimum of 1,6 mm clearance and creepage distance must be maintained. Beyond field wiring terminals, basic clearances must be 1,03 mm or greater, according to Table 47, and creepage distances must be 1,98 mm or greater, according to Table 52.

Zone 2: On a printed circuit board a minimum basic clearance of 2,25 mm must be maintained according to Table 47 for the working voltage of 450 V and a creepage of 2,85 mm from Table 54 because of the 1 600 V recurring peak.

At the isolation boundary to the SELV circuit the 2,3 mm clearance from Table 48 dominates the 1,85 mm creepage calculated by multiplying the interpolated value of 0,925 from Table 53 by 2 per 0 for double insulation. Therefore, a 2,3 mm minimum clearance and creepage distance must be maintained.

Zone 3: For SELV circuits, recurring peak voltages are not present, therefore only general safety requirements apply.

IEC 478/03

Annex ZA (normative)

Normative references to international publications with their corresponding European publications

This European Standard incorporates by dated or undated reference, provisions from other publications. These normative references are cited at the appropriate places in the text and the publications are listed hereafter. For dated references, subsequent amendments to or revisions of any of these publications apply to this European Standard only when incorporated in it by amendment or revision. For undated references the latest edition of the publication referred to applies (including amendments).

NOTE When an international publication has been modified by common modifications, indicated by (mod), the relevant EN/HD applies.

<u>Publication</u>	<u>Year</u>	<u>Title</u>	<u>EN/HD</u>	<u>Year</u>
IEC 60068-2-1	1990	Environmental testing Part 2: Tests - Tests A: Cold	EN 60068-2-1	1993
IEC 60068-2-2	1974	Part 2: Tests - Test B: Dry heat	EN 60068-2-2 ¹⁾	1993
IEC 60068-2-6 + corr. March	1995 1995	Part 2: Tests - Test Fc: Vibration (sinusoidal)	EN 60068-2-6	1995
IEC 60068-2-14	1984	Part 2: Tests - Test N: Change of temperature	EN 60068-2-14 ²⁾	1999
IEC 60068-2-27	1987	Part 2: Tests - Test Ea and guidance: Shock	EN 60068-2-27	1993
IEC 60068-2-30	1980	Part 2: Tests - Test Db and guidance: Damp heat, cyclic (12 + 12 hour cycle)	EN 60068-2-30 ³⁾	1999
IEC 60068-2-31	1969	Part 2: Tests - Test Ec: Drop and topple, primarily for equipment-type specimens	EN 60068-2-31 ⁴⁾	1993
IEC 60068-2-32	1975	Part 2: Tests - Test Ed: Free fall	EN 60068-2-32 ⁵⁾	1991
IEC 60417	series	Graphical symbols for use on equipment	EN 60417	series
IEC 60529	1989	Degrees of protection provided by enclosures (IP Code)	EN 60529 + corr May	1991 1993

¹⁾ EN 60068-2-2 includes IEC 60068-2-2A:1976.

²⁾ EN 60068-2-14 includes A1:1986 to IEC 60068-2-14.

³⁾ EN 60068-2-30 includes A1:1985 to IEC 60068-2-30.

⁴⁾ EN 60068-2-31 includes A1:1982 to IEC 60068-2-31.

⁵⁾ EN 60068-2-32 includes A2:1990 to IEC 60068-2-32.

<u>Publication</u>	<u>Year</u>	<u>Title</u>	<u>EN/HD</u>	<u>Year</u>
IEC 60664-1	1992	Insulation coordination for equipment within low-voltage systems Part 1: Principles, requirements and tests	EN 60664-1 ⁶⁾	2003
IEC 60664-3	1992	Part 3: Use of coatings to achieve insulation coordination of printed board assemblies	HD 625.3 S1 ⁷⁾	1997
IEC 60695-2-1/x	series	Fire hazard testing Part 2: Test methods – Section 1: Glow-wire test and methods	EN 60695-2-1/x ⁸⁾	series
IEC 60707	1999	Flammability of solid non-metallic materials when exposed to flame sources - List of test methods	EN 60707	1999
IEC 60947-5-1	1997	Low-voltage switchgear and controlgear Part 5-1: Control circuit devices and switching elements - Electromechanical control circuit devices	EN 60947-5-1 + A12	1997 1999
IEC 60947-7-1	2002	Part 7-1: Ancillary equipment - Terminal blocks for copper conductors	EN 60947-7-1	2002
IEC 60950-1 (mod)	2001	Information technology equipment - Safety Part 1: General requirements	EN 60950-1	2001
IEC 61000-4-2	1995	Electromagnetic compatibility (EMC) Part 4-2: Testing and measurement techniques - Electrostatic discharge immunity test	EN 61000-4-2	1995
IEC 61000-4-3	2002	Part 4-3: Testing and measurement techniques - Radiated, radio-frequency, electromagnetic field immunity test	EN 61000-4-3	2002
IEC 61000-4-4	1995	Part 4-4: Testing and measurement techniques - Electrical fast transient/burst immunity test	EN 61000-4-4	1995
IEC 61000-4-5	1995	Part 4-5: Testing and measurement techniques - Surge immunity test	EN 61000-4-5	1995
IEC 61000-4-6	1996	Part 4-6: Testing and measurement techniques - Immunity to conducted disturbances, induced by radio-frequency fields	EN 61000-4-6	1996

⁶⁾ EN 60664-1 includes A1:2000 + A2:2002 to IEC 60664-1.

⁷⁾ HD 625.3 S1 is superseded by EN 60664-3:2003, which is based on IEC 60664-3:2003.

⁸⁾ EN 60695-2-1/x are superseded by EN 60695-2-10 to EN 60695-2-13:2001, Fire hazard testing, Part 2-1X: Glowing/hot-wire based test methods.

<u>Publication</u>	<u>Year</u>	<u>Title</u>	<u>EN/HD</u>	<u>Year</u>
IEC 61000-4-8	1993	Part 4-8: Testing and measurement techniques - Power frequency magnetic field immunity test	EN 61000-4-8	1993
IEC 61000-4-12	1995	Part 4-12: Testing and measurement techniques - Oscillatory waves immunity test	EN 61000-4-12	1995
IEC 61010-1	2001	Safety requirements for electrical equipment for measurement, control, and laboratory use Part 1: General requirements	EN 61010-1 + corr June	2001 2002
CISPR 11 (mod)	1997	Industrial, scientific and medical (ISM) radio-frequency equipment - Radio disturbance characteristics - Limits and methods of measurement	EN 55011	1998
A1	1999		A1	1999
CISPR 16-1	1999	Specification for radio disturbance and immunity measuring apparatus and methods Part 1: Radio disturbance and immunity measuring apparatus	-	-
CISPR 16-2	1996	Part 2: Methods of measurement of disturbances and immunity	-	-
A1	1999		-	-

Bibliography

IEC 60038:1983, *IEC standard voltages*

IEV 60050(151):2001, *International Electrotechnical Vocabulary (IEV) – Part 151: Electrical and magnetic devices*

IEV 60050(161):1990, *International Electrotechnical Vocabulary (IEV) – Chapter 161: Electromagnetic compatibility*

IEV 60050(195), *International Electrotechnical Vocabulary (IEV) – Part 195: Earthing and protection against electric shock*

IEC 60112:1979, *Method for determining the comparative and the proof tracking indices of solid insulating materials under moist conditions*

IEC 60445:1999, *Basic and safety principles for man-machine interface, marking and identification – Identification of equipment terminals and of terminations of certain designated conductors, including general rules for an alphanumeric system*

IEC 60947-5-2:1997, *Low-voltage switchgear and controlgear – Part 5-2: Control circuit devices and switching elements – Proximity switches*

IEC 61140:2001, *Protection against electric shock – Common aspects for installation and equipment*

IEC 61506:1997, *Industrial-process measurement and control – Documentation of application Software*

IEC 62079:2001, *Preparation of instructions – Structuring, content and presentation*

BSI — British Standards Institution

BSI is the independent national body responsible for preparing British Standards. It presents the UK view on standards in Europe and at the international level. It is incorporated by Royal Charter.

Revisions

British Standards are updated by amendment or revision. Users of British Standards should make sure that they possess the latest amendments or editions.

It is the constant aim of BSI to improve the quality of our products and services. We would be grateful if anyone finding an inaccuracy or ambiguity while using this British Standard would inform the Secretary of the technical committee responsible, the identity of which can be found on the inside front cover.
Tel: +44 (0)20 8996 9000. Fax: +44 (0)20 8996 7400.

BSI offers members an individual updating service called PLUS which ensures that subscribers automatically receive the latest editions of standards.

Buying standards

Orders for all BSI, international and foreign standards publications should be addressed to Customer Services. Tel: +44 (0)20 8996 9001.
Fax: +44 (0)20 8996 7001. Email: orders@bsi-global.com. Standards are also available from the BSI website at <http://www.bsi-global.com>.

In response to orders for international standards, it is BSI policy to supply the BSI implementation of those that have been published as British Standards, unless otherwise requested.

Information on standards

BSI provides a wide range of information on national, European and international standards through its Library and its Technical Help to Exporters Service. Various BSI electronic information services are also available which give details on all its products and services. Contact the Information Centre.
Tel: +44 (0)20 8996 7111. Fax: +44 (0)20 8996 7048. Email: info@bsi-global.com.

Subscribing members of BSI are kept up to date with standards developments and receive substantial discounts on the purchase price of standards. For details of these and other benefits contact Membership Administration.
Tel: +44 (0)20 8996 7002. Fax: +44 (0)20 8996 7001.
Email: membership@bsi-global.com.

Information regarding online access to British Standards via British Standards Online can be found at <http://www.bsi-global.com/bsonline>.

Further information about BSI is available on the BSI website at <http://www.bsi-global.com>.

Copyright

Copyright subsists in all BSI publications. BSI also holds the copyright, in the UK, of the publications of the international standardization bodies. Except as permitted under the Copyright, Designs and Patents Act 1988 no extract may be reproduced, stored in a retrieval system or transmitted in any form or by any means – electronic, photocopying, recording or otherwise – without prior written permission from BSI.

This does not preclude the free use, in the course of implementing the standard, of necessary details such as symbols, and size, type or grade designations. If these details are to be used for any other purpose than implementation then the prior written permission of BSI must be obtained.

Details and advice can be obtained from the Copyright & Licensing Manager.
Tel: +44 (0)20 8996 7070. Fax: +44 (0)20 8996 7553.
Email: copyright@bsi-global.com.