

Measurement microphones —

Part 6: Electrostatic actuators for determination of frequency response

The European Standard EN 61094-6:2005 has the status of a
British Standard

ICS 17.140.50

National foreword

This British Standard is the official English language version of EN 61094-6:2005. It is identical with IEC 61094-6:2004.

The UK participation in its preparation was entrusted to Technical Committee EPL/29, Electro-acoustics, which has the responsibility to:

- aid enquirers to understand the text;
- present to the responsible European committee any enquiries on the interpretation, or proposals for change, and keep the UK interests informed;
- monitor related international and European developments and promulgate them in the UK.

A list of organizations represented on this committee can be obtained on request to its secretary.

Cross-references

The British Standards which implement international or European publications referred to in this document may be found in the *BSI Catalogue* under the section entitled “International Standards Correspondence Index”, or by using the “Search” facility of the *BSI Electronic Catalogue* or of British Standards Online.

This publication does not purport to include all the necessary provisions of a contract. Users are responsible for its correct application.

Compliance with a British Standard does not of itself confer immunity from legal obligations.

Summary of pages

This document comprises a front cover, an inside front cover, the EN title page, pages 2 to 27 and a back cover.

The BSI copyright notice displayed in this document indicates when the document was last issued.

Amendments issued since publication

Amd. No.	Date	Comments

This British Standard was published under the authority of the Standards Policy and Strategy Committee on 24 February 2005

© BSI 24 February 2005

ISBN 0 580 45431 2

EUROPEAN STANDARD

EN 61094-6

NORME EUROPÉENNE

EUROPÄISCHE NORM

January 2005

ICS 17.140.50

English version

Measurement microphones
Part 6: Electrostatic actuators for determination of frequency response
(IEC 61094-6:2004)

Microphones de mesure
Partie 6: Grilles d'entraînement
pour la détermination
de la réponse en fréquence
(CEI 61094-6:2004)

Messmikrofone
Teil 6: Elektrostatische Anregeelectroden
zur Ermittlung des Frequenzgangs
(IEC 61094-6:2004)

This European Standard was approved by CENELEC on 2004-12-01. CENELEC members are bound to comply with the CEN/CENELEC Internal Regulations which stipulate the conditions for giving this European Standard the status of a national standard without any alteration.

Up-to-date lists and bibliographical references concerning such national standards may be obtained on application to the Central Secretariat or to any CENELEC member.

This European Standard exists in three official versions (English, French, German). A version in any other language made by translation under the responsibility of a CENELEC member into its own language and notified to the Central Secretariat has the same status as the official versions.

CENELEC members are the national electrotechnical committees of Austria, Belgium, Cyprus, Czech Republic, Denmark, Estonia, Finland, France, Germany, Greece, Hungary, Iceland, Ireland, Italy, Latvia, Lithuania, Luxembourg, Malta, Netherlands, Norway, Poland, Portugal, Slovakia, Slovenia, Spain, Sweden, Switzerland and United Kingdom.

CENELEC

European Committee for Electrotechnical Standardization
Comité Européen de Normalisation Electrotechnique
Europäisches Komitee für Elektrotechnische Normung

Central Secretariat: rue de Stassart 35, B - 1050 Brussels

Foreword

The text of document 29/562/FDIS, future edition 1 of IEC 61094-6, prepared by IEC TC 29, Electroacoustics, was submitted to the IEC-CENELEC parallel vote and was approved by CENELEC as EN 61094-6 on 2004-12-01.

The following dates were fixed:

- latest date by which the EN has to be implemented at national level by publication of an identical national standard or by endorsement (dop) 2005-09-01
- latest date by which the national standards conflicting with the EN have to be withdrawn (dow) 2007-12-01

Annex ZA has been added by CENELEC.

Endorsement notice

The text of the International Standard IEC 61094-6:2004 was approved by CENELEC as a European Standard without any modification.

CONTENTS

1	Scope.....	5
2	Normative references	5
3	Terms and definitions	6
4	Reference environmental conditions	6
5	Principle of electrostatic actuator operation	6
5.1	General	6
5.2	Electrostatic pressure.....	7
5.3	Electrostatic actuator response	10
6	Actuator design	11
6.1	General	11
6.2	Design.....	11
7	Validation	12
7.1	General	12
7.2	Repeatability of measurements	12
7.3	Uniformity of actuators of a given model.....	12
7.4	Uniformity of the difference between actuator and pressure response levels	12
8	Measurement of electrostatic actuator response	13
8.1	System for measurement of electrostatic actuator response	13
8.2	Uncertainty components	14
9	Applications of an electrostatic actuator	16
9.1	General	16
9.2	Verification of the frequency response of a measurement system	16
9.3	Determination of the environmental characteristics of microphone measurement systems.....	16
9.4	Determination of free-field and pressure frequency responses.....	17
9.5	Measurement of actuator response at very high frequencies	17
Annex A (informative) Examples of electrostatic actuator designs		18
Annex B (informative) Set-up for measuring electrostatic actuator response		21
Annex C (informative) Typical uncertainty analysis		22
Annex D (informative) Difference between free-field-, pressure- and actuator responses for typical models of measurement microphones		25
Annex ZA (normative) Normative references to international publications with their corresponding European publications		27
Figure 1 – Principle of microphone and electrostatic actuator		8
Figure 2 – Lumped parameter model of a measurement microphone excited by an electrostatic actuator		10
Figure A.1 – Example of electrostatic actuator for type WS1 microphones		18
Figure A.2 – Example of an electrostatic actuator for type WS2 microphones		19
Figure A.3 – Examples of electrostatic actuators forming integral parts of the microphone protection grids.....		20

Figure A.4 – Example of an electrostatic actuator combined with weather-resistant protection	20
Figure B.1 – Typical set-up for measuring the electrostatic actuator response of a microphone.....	21
Figure D.1 – Examples of differences between relative pressure and actuator frequency responses for four different type of measurement microphone: WS1P (a), WS1F (b) of nominal sensitivities –26 dB re 1V/Pa and WS2P (c) and WS2F (d) of nominal sensitivities –38 dB re 1V/Pa	25
Figure D.2 – Examples of differences between relative free-field and actuator frequency responses for type WS1, WS2 and WS3 microphones when used without protection grids.....	25
Figure D.3 – Example of model dependent difference between relative free field and actuator frequency responses for a type WS2 microphone when used with its protection grid.....	26
Figure D.4 – Example on the determination of a relative free-field frequency response b) by adding the model dependent free-field to actuator difference as shown in Figure D.3 to the electrostatic actuator response of a microphone a)	26
Table C.1 – Uncertainties	24

MEASUREMENT MICROPHONES –

Part 6: Electrostatic actuators for determination of frequency response

1 Scope

This part of IEC 61094

- gives guidelines for the design of actuators for microphones equipped with electrically conductive diaphragms;
- gives methods for the validation of electrostatic actuators;
- gives a method for determining the electrostatic actuator response of a microphone.

The applications of electrostatic actuators are not fully described within this standard but may include

- a technique for detecting changes in the frequency response of a microphone,
- a technique for determining the environmental influence on the response of a microphone,
- a technique for determining the free-field or pressure response of a microphone without specific acoustical test facilities, by the application of predetermined correction values specific to the microphone model and actuator used,
- a technique applicable at high frequencies not typically covered by calibration methods using sound excitation.

2 Normative references

The following referenced documents are indispensable for the application of this document. For dated references, only the edition cited applies. For undated references, the latest edition of the referenced document (including any amendments) applies.

IEC 61094-1, *Measurement microphones – Part 1: Specifications for laboratory standard microphones*

IEC 61094-2, *Measurement microphones – Part 2: Primary method for pressure calibration of laboratory standard microphones by the reciprocity technique*

IEC 61094-3, *Measurement microphones – Part 3: Primary method for free-field calibration of laboratory standard microphones by the reciprocity technique*

IEC 61094-5, *Measurement microphones – Part 5: Methods for pressure calibration of working standard microphones by comparison*

ISO/IEC GUIDE EXPRESS: 1995, *Guide to the expression of uncertainty in measurement (GUM)*

3 Terms and definitions

For the purposes of this document, the terms and definitions given in IEC 61094-1 as well as the following apply.

3.1

electrostatic actuator

device for determination of microphone frequency response comprising an electrically conductive stiff plate placed near the microphone diaphragm such that a time-varying voltage, applied between the plate and the diaphragm, produces an electrostatic force that simulates a sound pressure uniformly distributed over the surface of the diaphragm

3.2

electrostatic actuator response of a microphone

microphone output as a function of frequency measured using a specified design of electrostatic actuator driven by a voltage that is of uniform amplitude with frequency, relative to the output at a specified frequency

NOTE Electrostatic actuator response is expressed in decibels (dB).

3.3

acoustic radiation impedance

acoustic impedance loading the microphone diaphragm on its outer surface

NOTE 1 Acoustic radiation impedance is expressed in pascal-second per cubic meter ($\text{Pa}\cdot\text{s}\cdot\text{m}^{-3}$).

NOTE 2 The radiation impedance depends on the presence and design of the actuator.

4 Reference environmental conditions

The reference environmental conditions are:

temperature	23,0 °C
static pressure	101,325 kPa
relative humidity	50 %

5 Principle of electrostatic actuator operation

5.1 General

In practice, measurements of sound are made in many different environments where different types of sound fields exist. The sensitivity and frequency response of measurement microphones depend on the type of sound field, so ideally the microphone should be calibrated using a similar type of field to that which exists on the measurement site. The various types of sound fields are generally approximated by three idealized fields: free field, diffuse-field and pressure-field.

However, the establishment of such idealized sound fields, which are suitable for calibration of measurement microphones over the frequency ranges of interest is technically difficult and requires costly acoustical laboratory facilities. Therefore, the electrostatic actuator method is used for determining a relative frequency response of measurement microphones. This method, which accounts for the type of sound field by using specific predetermined corrections, requires no such facilities.

At higher frequencies, the free-field sensitivity of a microphone is determined by the behaviour of its diaphragm and the sound diffraction and reflection caused by the microphone.

The effect of the diaphragm behaviour, which may cause significant differences in the relative frequency responses between individual microphones of the same model, requires specific determination. This frequency response determination is performed using the electrostatic actuator method.

The effect of the diffraction and reflection depends on the type of sound field and on the shape and dimensions of the microphone. As these parameters are essentially the same for all microphones of the same model, the influence of diffraction and reflection does not differ significantly between individual microphones of the same model.

Therefore, corrections for specific types of sound field may be determined once for a model of microphone and subsequently applied to the electrostatic actuator response of any microphones of that model.

Free-field and pressure-field corrections are calculated by determining the respective frequency responses of one or more microphones of the same model by using acoustical calibration methods, for example, those in IEC 61094-2 and IEC 61094-3, and by subtracting the respective electrostatic actuator responses.

In principle, the electrostatic actuator calibration method may be used from very low to very high frequencies. However, the actuator excites the microphone diaphragm only and not the static pressure equalisation vent, which is generally exposed to sound when measurements are made in a free-field. The actuator excitation corresponds to that of a pressure-field and thus cannot be used for determination of the lower limiting frequency under free-field conditions. Free-field response determinations by electrostatic actuator should only be made at frequencies which are at least 10 times greater than the lower limiting frequency derived from the time constant of the venting system of the microphone. At low frequencies, a small perforation in the microphone diaphragm will exhibit different effects in the actuator response and in the acoustic responses in a pressure field or a free field. At high frequencies, the degree to which the actuator excitation approximates that of a pressure field depends on the relation between the acoustic impedance of the microphone diaphragm and the acoustic radiation impedance of the microphone diaphragm with the actuator in place. This relation is described in 5.3, while 9.3 describes some practical consequences for the determination of the environmental characteristics of a microphone.

5.2 Electrostatic pressure

The rigid and electrically conductive plate of the actuator is placed close to and parallel to the microphone diaphragm, see Figure 1. It forms an electrical capacitor together with the microphone diaphragm, which shall also be electrically conductive. When a voltage is applied between the capacitor plates, the actuator produces a force F distributed over the diaphragm surface; see Equation (1) below.

The corresponding electrostatically produced pressure p_{act} is defined by Equation (2). Edge effects are neglected. The ratio between the effective actuator area and the active diaphragm area gives a constant, which is generally less than unity because the actuator is perforated for acoustic reasons.

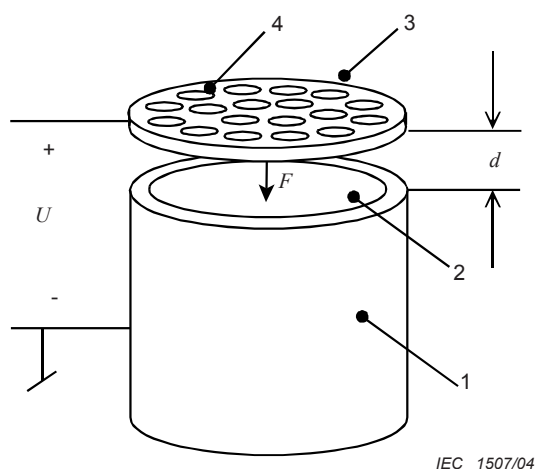
**Key**

- 1 Microphone housing
- 2 Microphone diaphragm. Area S_{dia}
- 3 Electrostatic actuator. Area S_{act}
- 4 Holes

Figure 1 – Principle of microphone and electrostatic actuator

$$F = -\frac{\epsilon_{\text{gas}} S_{\text{act}}}{2d^2} U^2 \quad (1)$$

$$p_{\text{act}} = \frac{F}{S_{\text{dia}}} = -\frac{\epsilon_{\text{gas}}}{2d^2} a U^2 \quad (2)$$

where

F is the electrostatic force produced on diaphragm (a pushing or pulling force is considered to be positive or negative respectively), in newtons (N);

p_{act} is the electrostatically produced pressure on the diaphragm, in pascals (Pa);

ϵ_{gas} is the dielectric constant of gas in space between actuator and diaphragm, in farads per meter (F/m) (in air: $\epsilon_{\text{gas}} = 8,85 \times 10^{-12}$ F/m);

d is the effective distance between actuator and diaphragm, in meters (m);

S_{dia} is the active diaphragm area, in square meters (m²);

S_{act} is the effective surface area of actuator above the active diaphragm area, in square meters (m²);

$a = \frac{S_{\text{act}}}{S_{\text{dia}}}$ is the ratio between effective actuator area and active diaphragm area;

U is the voltage applied between actuator and microphone diaphragm, in volts (V).

Actuators are generally operated with a d.c voltage and a superimposed sinusoidal a.c voltage. Equation (3) describes the instantaneous electrostatic pressure on the diaphragm for this mode of operation.

$$p(t) = -\frac{\varepsilon_{\text{gas}} a}{2d^2} \left(U_0 + u\sqrt{2} \sin(\omega t) \right)^2 \quad (3)$$

The Equations (4), (5) and (6) describe the resulting electrostatic pressure components, which include the desired equivalent sound pressure p at the fundamental frequency and two non-desired components, a 2nd harmonic pressure p_d and a static pressure p_{stat} .

$$p = \frac{\varepsilon_{\text{gas}} a}{d^2} U_0 u \quad (4)$$

$$p_d = \frac{\varepsilon_{\text{gas}} a}{2\sqrt{2} d^2} u^2 \quad (5)$$

$$p_{\text{stat}} = -\frac{\varepsilon_{\text{gas}} a}{2d^2} \left(U_0^2 + u^2 \right) \quad (6)$$

where

- $p(t)$ is the equivalent instantaneous sound pressure, in pascals (Pa);
- p is the r.m.s. value of the sound pressure at the fundamental frequency, in pascals (Pa);
- p_d is the r.m.s. value of the sound pressure at the 2nd harmonic frequency, in pascals (Pa);
- p_{stat} is the static pressure, in pascals (Pa);
- t is the time, in seconds (s);
- U_0 is the d.c. voltage applied between actuator and microphone diaphragm, in volts (V);
- u is the r.m.s. value of the a.c. voltage applied between actuator and microphone diaphragm, in volts (V);
- ω is the angular frequency, in radians per second (rad/s).

The equation below defines the fraction of distortion, i.e. the ratio between the magnitudes of the second harmonic and the fundamental frequency components:

$$D = \frac{u}{2\sqrt{2}U_0} 100 \% \quad (7)$$

Examples of the design of electrostatic actuators are given in Annex A and an example of a measurement set-up in Annex B.

NOTE 1 Although Equation (4) describes the absolute value of the equivalent sound pressure produced on the microphone diaphragm, the actuator method is usually only used for measurement of relative frequency response. The method might be used for determination of absolute microphone sensitivity but the resulting uncertainty would generally be too large for most applications. Relatively large uncertainty is associated with the determination of the distance d and with the ratio of areas a .

NOTE 2 Actuators may also be operated with a.c. voltage only. Equations (3), (4), (5) and (6) are also valid for this mode of operation ($U_0 = 0$). It should be noticed that the frequency of the electrostatically produced equivalent pressure becomes twice the frequency of the supplied electrical signal, and that any variation of voltage input level causes a change in this equivalent sound pressure level that is twice as large.

NOTE 3 The influence of the distortion of the excitation signal, see equation (7), on the microphone output signal depends on the frequency response of the microphone. This influence can be eliminated by using a selective measurement technique to measure the fundamental frequency component only.

5.3 Electrostatic actuator response

The electrostatic actuator method uses an electrostatically produced pressure to excite the microphone diaphragm. A constant electrostatic pressure may in practice be produced on a microphone diaphragm over a wide frequency range by keeping the driving a.c. voltage constant while its frequency is varied.

The movement of the microphone diaphragm caused by the electrostatic excitation produces a sound pressure on the diaphragm in addition to the electrostatic pressure. This pressure is a function of frequency as it depends on both the diaphragm impedance and on the radiation impedance.

The difference between the pressure response and the electrostatic actuator response can be described by the equivalent circuit model in Figure 2.

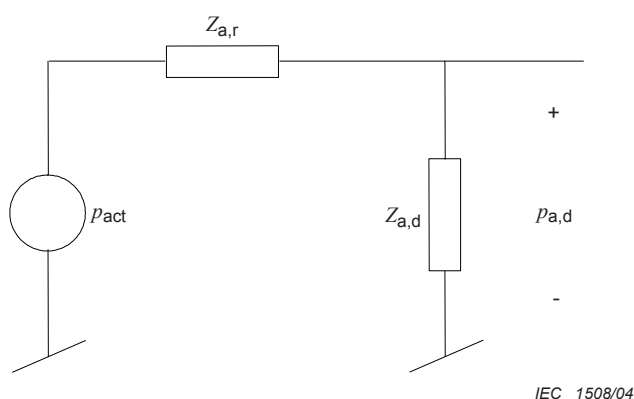

Components

- $Z_{a,d}$ acoustic impedance of the microphone diaphragm for unloaded electrical terminals, in pascal-seconds per cubic meter ($\text{Pa}\cdot\text{s}\cdot\text{m}^{-3}$);
- $Z_{a,r}$ acoustic radiation impedance of the diaphragm with the actuator in place, in pascal-second per cubic meter ($\text{Pa}\cdot\text{s}\cdot\text{m}^{-3}$);
- $p_{a,d}$ Resulting equivalent sound pressure acting on the diaphragm, in pascals (Pa).

Figure 2 – Lumped parameter model of a measurement microphone excited by an electrostatic actuator

The resulting influence on the pressure acting on the diaphragm is then given by the ratio

$$\frac{p_{a,d}}{p_{act}} = \frac{Z_{a,d}}{Z_{a,d} + Z_{a,r}} \quad (8)$$

For microphones having high diaphragm impedance, the additional sound pressure becomes relatively low and the measured response becomes essentially equal to the pressure response of the microphone.

The radiation impedance and the measured response are influenced by the mechanical configuration of the electrostatic actuator itself. To keep the influence of the electrostatic actuator as low as possible, actuators are generally perforated by either holes or slots. A high percentage of perforation will reduce the influence of the actuator on the radiation impedance but could also result in a lower pressure and less uniform distribution across the diaphragm.

To determine the frequency responses valid for free-field and pressure-field conditions, microphone and actuator model-specific corrections shall be added to the measured actuator response.

6 Actuator design

6.1 General

The actuator shall be designed such that the microphone is not damaged and the sensitivity is not unduly affected when the actuator is applied.

6.2 Design

The difference between the actuator response of a microphone and its free-field, pressure and diffuse-field responses respectively are essentially the same for all microphones of the same model. Therefore, once these differences have been determined and made available, either one of the three responses can be calculated after measurement of the actuator response.

An electrostatic actuator shall be designed to measure a response, which for all microphones of the same model forms essentially fixed differences to the free-field and pressure responses respectively.

The above design criteria lead to the following requirements:

- a) measurements made with a given actuator shall be reproducible;
- b) measurements made with actuators of a given design shall be reproducible with the same microphone;
- c) the acoustic influence of the actuator itself on the measured response shall be essentially the same for all microphones of the same model.

To obtain reproducible results with the actuator, no significant change should occur in the measured response by rotating the actuator relative to the microphone. This means that the actuator should produce an essentially uniform and rotationally symmetric distribution of the electrostatic pressure over the diaphragm. This may be obtained by making the dimensions of pattern details (hole diameters or slot widths) small compared to typical details of microphone backplate designs. It is, therefore, recommended to keep the dimensions of any such details less than 15 % of the microphone diaphragm diameter and the percentage of perforation of 40 % or more. Typical degrees of perforation are between 40 % and 50 %.

To obtain the same results with different actuators of the same model, the actuators should be produced with narrow tolerances. The variations for a given model of actuator on the distance between actuator and diaphragm, the percentage of perforation and the thickness of the actuator should be within ± 5 % of the nominal value.

The presence of the electrostatic actuator changes the radiation impedance of the microphone, and thus also affects the resulting pressure acting on the diaphragm; see Figure 2 and Equation (8). The resulting radiation impedance, which is in series with the microphone impedance, should be low to ensure that the influence of the actuator becomes essentially the same for all microphones of the same model, even if their diaphragm impedance varies within the limits associated with the model of microphone. This means that actuators generally need to be designed with a high degree of perforation as mentioned above.

NOTE Designers and users of actuators should be aware that actuators and their possible fixtures may resonate at certain frequencies and disturb frequency response measurements in narrow frequency ranges around the resonances.

7 Validation

7.1 General

Validation of a model of electrostatic actuator is made by performing tests, which prove that the actuator conforms to the requirements given in 6.2.

The performance of an actuator depends on the properties of the microphone to be measured. Therefore, the actuator should be tested with all models of microphones for which it is to be used.

Testing of a model of actuator with a model of microphone requires a minimum of 3 actuators and 3 microphones of the selected models.

7.2 Repeatability of measurements

One of the actuators shall be tested with one of the microphones. Measurements of electrostatic actuator response shall be replicated ten times. The actuator shall be fully removed from and replaced on the microphone between the measurements. The specified frequency of the electrostatic actuator responses (see 3.2) shall be the same for all replications (250 Hz is recommended). The experimental standard deviation of the results shall be calculated and not exceed 0,04 dB at any frequency.

NOTE The angle of rotation between the actuator and the microphone should be different for the 10 reproductions of the measurements except for actuators which are an integral part of a microphone diaphragm protecting grid.

7.3 Uniformity of actuators of a given model

All the actuators shall be tested with a microphone that has been randomly selected. Five repetitions of electrostatic actuator response measurement shall be performed with each actuator. The recommended specified frequency for these measurements is 250 Hz, and the average of the five repetitions shall be calculated for each actuator. None of these average responses shall at any frequency deviate more than 0,06 dB from the average of all measurements.

NOTE This test does not apply to actuators which are integral parts of microphone diaphragm protection grids.

7.4 Uniformity of the difference between actuator and pressure response levels

One of the actuators is randomly selected and used to measure the electrostatic actuator response of each microphone. The recommended specified frequency for these measurements is 250 Hz, and the average of five repetitions shall be calculated for each microphone.

The pressure response shall be measured for each microphone using the methods specified in IEC 61094-2 or IEC 61094-5.

The difference between the average actuator response and the pressure response level shall be calculated for each microphone. None of these differences shall deviate from their mean value by more than 0,1 dB.

8 Measurement of electrostatic actuator response

8.1 System for measurement of electrostatic actuator response

Systems for measurement of electrostatic actuator response of a microphone consist of two parts: a system for electrostatic excitation of the microphone diaphragm and a system for determination of the microphone output voltage. Elements of a typical measurement system are shown in Annex B, Figure B.1.

The system may either measure the response of a microphone with its associated preamplifier or the open circuit response of the microphone itself. In the latter case the insert voltage technique shall be used to correct for the influence of loading of the microphone.

The applied model of actuator shall fulfil the requirements given in Clause 7. The actuator shall be operated such that the microphone is not damaged and such that its sensitivity is not unduly affected when the actuator is positioned on the microphone.

The electrostatic actuator response of a microphone is influenced by environmental conditions. Ambient pressure, temperature and relative humidity shall thus be measured and stated together with the measured microphone response.

When setting up a measurement system it shall be ensured that cross-talk, which may occur between the excitation part and the measuring part of the measurement system, does not significantly influence the measurement result. It shall also be ensured that the static pressure component of the actuator-generated pressure is so small that it does not significantly modify the frequency response of the microphone by displacing its diaphragm.

8.1.1 Cross-talk

Typically the a.c. voltage that is applied to an electrostatic actuator is 30 V. This voltage leads to an electrostatically produced pressure of about 1 Pa and to output voltages of 0,3 mV to 100 mV, depending on the frequency and on the model of measurement microphone. This results in a level difference of 50 dB to 100 dB between the excitation voltage on the actuator and the output voltage of the microphone. For example, to ensure that a cross-talk signal arising from the excitation voltage does not influence the measured output voltage from the microphone by more than 0,03 dB, the cross-talk signal needs to be 50 dB below the microphone output signal. Thus, differences in level as high as 100 dB to 150 dB between actuator signal and microphone cross-talk signal may be necessary, depending on the required uncertainty and model of microphone. Further information is given in Annex B.

8.1.2 Static attraction force

The presence of a d.c. voltage between actuator and microphone diaphragm results in a static attraction force which can be derived from Equation (6). This force results in a change of the diaphragm to backplate distance in the microphone and consequently a small change in the sensitivity of the microphone, in particular around the resonance frequency. The estimated influence of this effect is less than 0,05 dB if the following criterion is fulfilled:

$$\frac{M_p \cdot p_{\text{stat}}}{U_{\text{pol}}} < 2 \cdot 10^{-3} \quad (9)$$

where

M_p is the pressure sensitivity of the microphone, in volts per pascal (V/Pa);

p_{stat} is the static attraction force per unit area given by Equation (6), in pascals (Pa);

U_{pol} is the external or equivalent internal polarization voltage of the microphone, in volts (V).

For a nominal distance of 0,5 mm between actuator and diaphragm the d.c. voltage applied to the actuator is typically about 800 V.

The a.c. and d.c. voltage applied to the actuator shall be chosen such that the distortion as given by Equation (7) does not influence the measured response significantly. Particular care should be taken if the microphone itself or the surrounding environment introduces high peaks in the resulting response.

NOTE 1 It should be ascertained that the electrical field strength between the actuator and the microphone diaphragm created by the applied d.c. and a.c. voltage is well below the breakdown voltage for the gas in use in order to avoid ionic discharges. For many gases, it should be noted that the breakdown voltage is lower than for air. An excessive amount of dust or other deposits on the diaphragm may increase the risk of ionic discharges.

NOTE 2 Actuators are generally not fully insulated which represents a risk to the operator when a high d.c. and a.c. voltage is applied to the actuator. This means that the electrical safety requirements, which are valid for the laboratory or other site of use, must be followed. Such requirements generally set upper limits for the current, which might inadvertently be drawn from the voltage supply for the actuator.

8.2 Uncertainty components

8.2.1 General

In addition to the factors that influence the response of the microphone, further uncertainty components are introduced by the measurement method, the equipment and the degree of care under which the measurement is carried out. Factors, which affect the measurement in a known way, shall be measured or calculated with as high an accuracy as practicable in order to minimise their influence on the resulting uncertainty.

8.2.2 Electrical frequency response of measurement equipment

The frequency response of the entire measurement system that generates the electrical excitation signal for the actuator and measures the microphone output signal, should either be essentially constant or accounted for by correcting the measurement result. The overall frequency response may be measured by applying a fraction of the a.c. excitation signal to the input of the system that measures the microphone output signal. Where the open-circuit response is to be determined, the signal shall be applied as an insert voltage signal in series with the microphone itself. During the test the system settings shall be the same as those applied for the actuator response measurement and the order of magnitude of the test signal shall be equal to that of the microphone output signal.

8.2.3 Cross-talk of measurement system

Signals due to cross-talk are correlated with the true measurement signal and adds linearly to the microphone output signal. For example, to ensure an influence of less than 0,03 dB, the magnitude of the cross-talk signal needs to be at least 50 dB below the microphone output signal.

8.2.4 Inherent electrical and environmental acoustic noise

Noise that is non-correlated with the true measurement signal adds to the output signal on r.m.s. basis. For example, to ensure an influence of less than 0,03 dB the magnitude of the noise needs to be at least 25 dB below the signal.

8.2.5 Distortion

The electrostatic pressure produced by an electrostatic actuator is distorted; see 5.2, Equation (3). The influence of the distortion on the measured response depends on the applied measurement principle. In case of frequency-selective measurements the influence may be eliminated. In case of non-selective measurements some influence on the measured frequency response may occur if a significant difference is present between the microphone sensitivity at the measurement frequency and at its harmonic components.

Therefore, with non-selective measurements there can be some influence within the frequency range, where the actuator response changes with frequency. For example, to keep this influence below 0,05 dB, when measuring the frequency response of working standard microphones, the distortion shall not exceed 5 %.

8.2.6 Radiation impedance

The motion of the microphone diaphragm, caused by the electrostatic pressure, creates a sound pressure on the outer surface of the diaphragm that adds to the electrostatic pressure and influences the measured response. The influence of this sound pressure depends on the radiation impedance that loads the surface. So it is necessary for the microphone response to be measured under fully open conditions.

Therefore, it shall be ensured that reflecting surfaces or the use of any enclosure (for the reduction of ambient noise for example) do not significantly influence the radiation impedance and the measured response of the microphone. It shall be experimentally verified that measurement results obtained at the measurement site are essentially equal to results obtained in an open space.

This uncertainty component shall be taken as the difference between the responses and in general should not exceed 0,05 dB.

NOTE Usually the influence of the measurement site is most critical for microphones of high sensitivity.

8.2.7 Reproducibility of measurement

The reproducibility is determined by the stability of the microphone, the environmental conditions, the measurement instruments and the electrostatic actuator. The uncertainty related to the actuator is partly due to its positioning on the microphone and partly due to the tolerance of dimensions for the model of actuator. Limits of these uncertainty components are given in Clause 7.

8.2.8 Uncertainty on electrostatic actuator response

It is estimated that a determination of an electrostatic actuator response according to this standard can achieve an expanded uncertainty with coverage factor 2 (see ISO/IEC GUIDE EXPRESS (GUM)) of 0,1 to 0,2 dB up to 10 kHz for types of WS1 and WS2 working standard microphones. Annex C contains an example of an uncertainty analysis for a WS2 microphone having a nominal sensitivity of 50 mV/Pa.

NOTE This uncertainty estimate is for the actuator response only. If other factors are used to determine an acoustic response, for example the microphone sensitivity at the reference frequency or actuator to free-field or pressure response corrections, then the uncertainty in these factors also needs to be included.

9 Applications of an electrostatic actuator

9.1 General

Full descriptions of the applications of electrostatic actuators, including detailed uncertainty analyses, are beyond the scope of this standard. However, the information given in this clause provides some guidance on what is possible using these devices.

9.2 Verification of the frequency response of a measurement system

The overall frequency response of a measurement system can be monitored over time by using an electrostatic actuator to simulate a sound pressure on the microphone diaphragm. The system under test can be a single instrument like a handheld sound level meter or a complex system like an outdoor sound monitoring system (see for example IEC 61672-1¹), where the microphone(s) and the associated preamplifier(s) are separated from the indicating part of the system. In both cases, the electrostatic actuator may form an integral part of the microphone diaphragm protection grid.

Verification of frequency response stability of a microphone or a system can be performed by making an initial actuator frequency response measurement followed by corresponding periodic measurements, if all measurements are performed with the same model of actuator. The time between verifications depends on the requirements and performance of the system.

The reproducibility of the frequency response measurement is highly dependent on the actual measurement system and the prevailing environmental conditions.

9.3 Determination of the environmental characteristics of microphone measurement systems

Determination of the frequency response of a microphone under varying environmental conditions is difficult using acoustical excitation of the microphone. In practice, the influence of the environmental conditions on the sound source and on sound propagation makes it necessary to excite the microphone under test by other means. The electrostatic actuator method is suited for the purposes as the electrostatic pressure is essentially independent of the environmental conditions, see Equation (4). However, the radiation impedance is influenced by static pressure, temperature and humidity. This variation in environmental conditions will influence the measured response of the microphone at frequencies in the upper part of its operation range, see Equation (8). The influence is generally small but should be analysed and evaluated.

NOTE 1 The frequency response determined with an electrostatic actuator does not include the effect of diffraction around the microphone. See IEC 61094-3. For the free-field environmental characteristics of microphones the influence of temperature variations on the diffraction term may be larger at high frequencies than the influence on the radiation impedance.

NOTE 2 If an electrostatic actuator is used for testing the influence of temperature on the response of a microphone, the equivalent sound pressure produced by an electrostatic actuator should be independent of temperature. Therefore, the distance between the actuator and the diaphragm must be kept essentially constant; see Equation (4). Design of actuators should thus be made with specific attention to the minimization of the effect of temperature on the actuator to diaphragm distance.

1 IEC 61672-1, *Electroacoustics – Sound level meters – Part 1: Specifications*

9.4 Determination of free-field and pressure frequency responses

The electrostatic actuator frequency response of a microphone can be used for determination of relative free-field and pressure sensitivities by applying pre-determined corrections. For each model and configuration of microphones there are essentially fixed ratios (differences in decibel) between the responses applicable to the various types of sound field and the response measured by a specific design of electrostatic actuator.

For the free-field sensitivities the magnitude and the phase of these ratios are predominantly determined by the shape and size of the microphone and its diaphragm protection grid while the acoustic impedance of the diaphragm has a smaller influence. For the pressure sensitivity, the magnitude and phase of the ratio is only influenced by the relation between the acoustic impedance of the diaphragm and the radiation impedance, see Equation (8).

In cases where these field-type dependent ratios have been determined by the microphone manufacturer or an acoustical calibration laboratory, the free-field and pressure responses for a type of microphone may be determined by applying the relevant corresponding corrections to the measured electrostatic actuator response.

Examples of the various corrections are shown in Annex D.

NOTE 1 The specification or type of actuator should be reported with the measurement result as the actuator configuration may significantly influence the measured frequency response.

NOTE 2 When pre-determined corrections are used for determination of the relative free-field response, the low frequency limitations of 5.1 should be observed.

NOTE 3 When additional factors are used to determine an acoustic response, for example the microphone sensitivity at the reference frequency or actuator to free-field or pressure response corrections, then the uncertainty in these additional factors needs to be combined with the uncertainty in the actuator response to obtain the overall uncertainty in the frequency response.

9.5 Measurement of actuator response at very high frequencies

Acoustical calibration methods for measurement microphones are limited in the maximum frequency at which they remain valid or practical.

Measurement of the electrostatic actuator frequency response is not limited in the same way. Provided the same precautions outlined in Clause 8 are taken regarding noise, cross talk etc. the method can be implemented beyond the range of the microphone under test.

There are however no data available to correct the actuator response to obtain a pressure or free-field response of a microphone. However, in this frequency range the electrostatic actuator may be the only option available for determining a response of the microphone.

Annex A (informative)

Examples of electrostatic actuator designs

A.1 Actuator for type WS1 microphones

A commonly used design of an electrostatic actuator for type WS1 microphones is shown in Figure A.1.

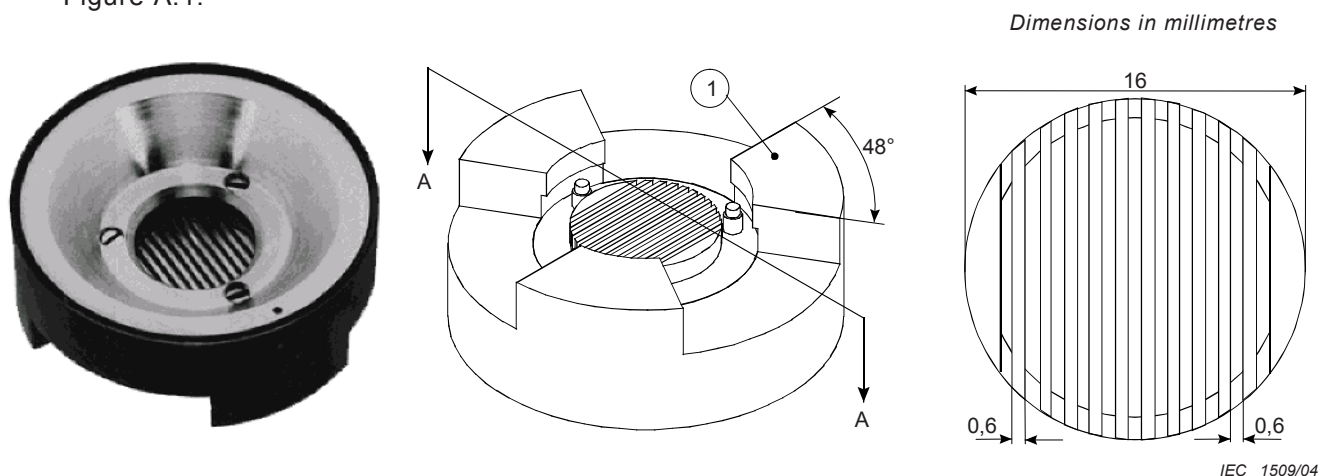

Key

- 1 One of three equally spaced positioning guides

Figure A.1a – Actuator surface pattern

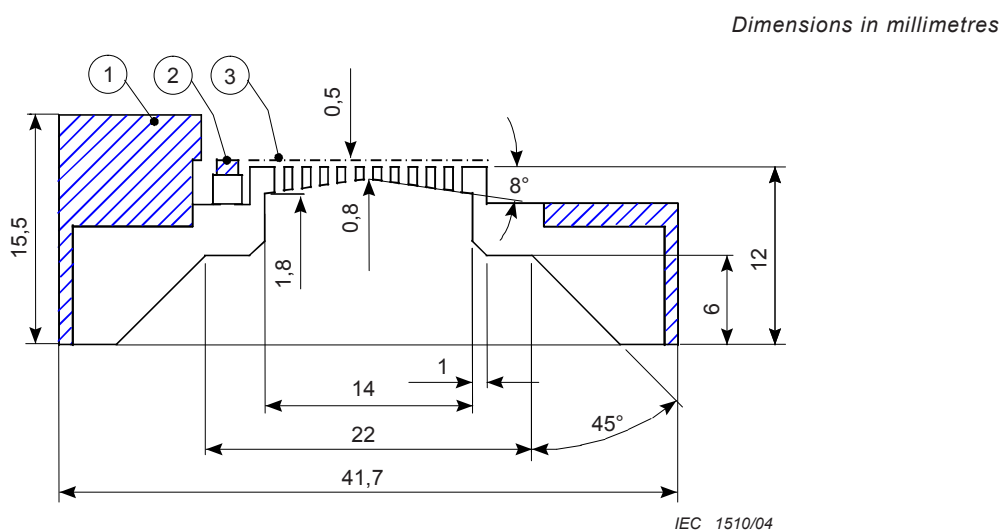

Key

- 1 Insulating positioning guide
2 Insulating supports adjusted to an actuator to diaphragm distance of 0,5 mm
3 Position of diaphragm

Figure A.1b – Sectional view A – A

Figure A.1 – Example of electrostatic actuator for type WS1 microphones

The actuator may be used for microphones of smaller dimensions by using mechanical adaptors mounted on the microphones to simulate a WS1 microphone.

A.2 Actuator for type WS2 microphones

A commonly used design of an electrostatic actuator for type WS2 microphones is shown in Figure A.2.

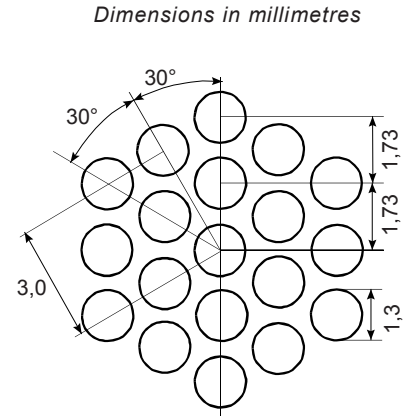
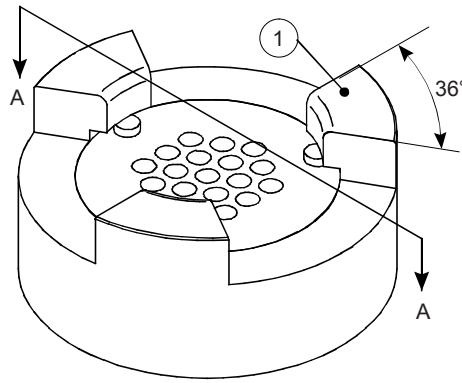

IEC 1511/04

key

- 1 One of three equally spaced positioning guide

Figure A.2a – Actuator surface pattern centrally positioned on the actuator

Dimensions in millimetres

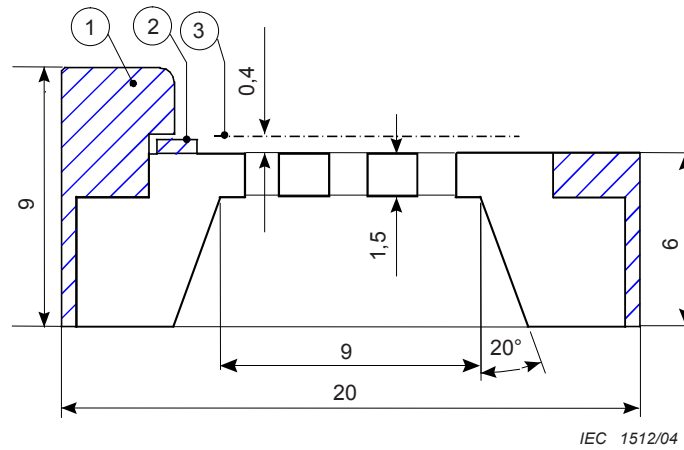

IEC 1512/04

Key

- 1 Insulating positioning guide
- 2 Insulating supports adjusted to an actuator to diaphragm distance of 0,4 mm
- 3 Position of diaphragm

Figure A.2b – Sectional view A – A

Figure A.2 – Example of an electrostatic actuator for type WS2 microphones

The actuator may be used for microphones of smaller dimensions by using mechanical adaptors mounted on the microphones to simulate a WS2 microphone.

A.3 Actuators forming integral parts of protection grids

Examples of actuators forming integral parts of microphone diaphragm protection grids are shown below in Figures A.3 and A.4.



IEC 1513/04

Figure A.3 – Examples of electrostatic actuators forming integral parts of the microphone protection grids

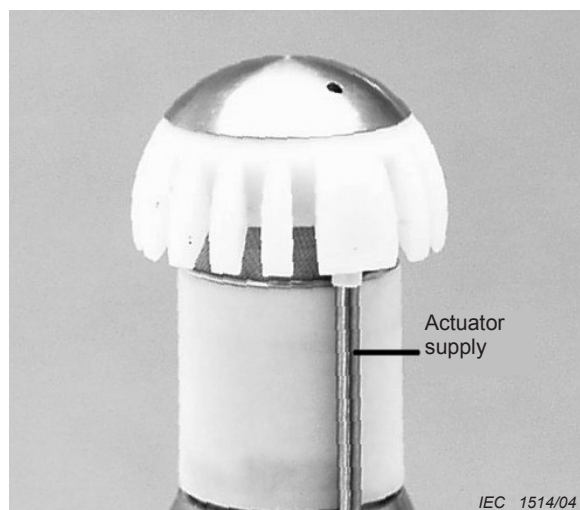

Figure A.4 – Example of an electrostatic actuator combined with weather-resistant protection

Annex B (informative)

Set-up for measuring electrostatic actuator response

Figure B.1 shows a typical set-up for measurement of frequency response using an electrostatic actuator. The electrostatic actuator is driven via a capacitor and a resistor from an a.c. and a d.c. voltage source respectively. The impedance of the electrical components should be selected so that the a.c. voltage is not attenuated significantly at the lowest frequency of interest. The harmonic distortion of the equivalent sound pressure is determined by the ratio of the a.c. to d.c. voltages, see Equation (7). If the total r.m.s. value of the microphone output is measured, the applied d.c. voltage should be at least 10 times larger than the a.c. voltage. Attention should also be paid to the safety of the operator by selecting proper voltages and components impedances.

The combination of the relatively high a.c. actuator supply voltage and the relatively low microphone output voltage implies a risk of significant measurement errors due to electrical cross-talk. This is particularly important for microphones having a low sensitivity and for measurements made at high frequencies.

For externally polarized microphones cross-talk may be checked by setting the microphone polarizing voltage supply to '0 V'. For pre-polarized microphones the actuator d.c. voltage supply should be set to '0 V'. The microphone output voltage at the a.c.-signal frequency should then fall by 50 dB or more over the entire frequency range. If the voltage falls by 50 dB, the measurement error may be up to 0,03 dB, but the error will be highly dependent on the phase angle between the desired and the undesired signals.

Cross-talk may be reduced by proper selection of ground connection points and wiring between the instruments.

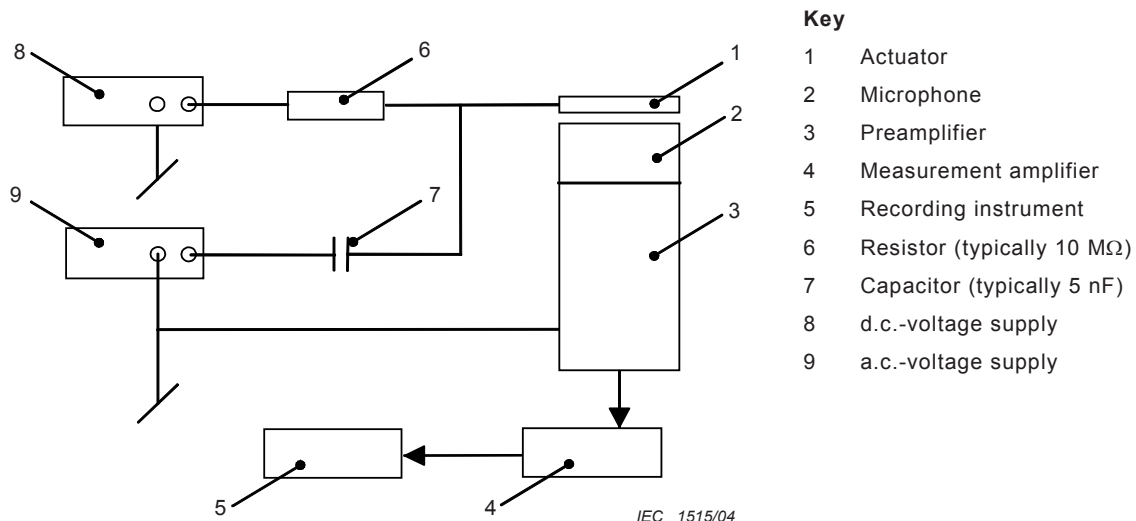

Figure B.1 – Typical set-up for measuring the electrostatic actuator response of a microphone

The measurements should be performed in a suitable acoustic environment. The ambient noise should be kept well below the applied electrostatic pressure (see Equation (4)) in order to minimize its influence on the measurements. Close-by surfaces resulting in strong acoustical reflections at the position of the microphone should also be avoided.

Annex C (informative)

Typical uncertainty analysis

C.1 Introduction

The following is an example of how the uncertainties would be calculated for a hypothetical measurement protocol. It should not be taken to be an exhaustive list of possible uncertainties, or a guide to typical values, but just a guide to calculation method required by the ISO/IEC GUIDE EXPRESS (GUM).

C.2 Analysis

The uncertainties given in Table C.1 are derived for a single frequency at 10 kHz for a type WS2F microphone with a nominal sensitivity of 50 mV/Pa at the reference frequency, 250 Hz.

The ratio between the microphone output voltage at the measurement and reference frequencies is expressed by Equation (C.1)

$$\frac{u_{\text{out}}(f)}{u_{\text{out,ref}}} = \frac{p(f)}{p_{\text{ref}}} \cdot \frac{M_{\text{a}}(f)}{M_{\text{a,ref}}} \quad (\text{C.1})$$

where

$\frac{u_{\text{out}}(f)}{u_{\text{out,ref}}}$ is the ratio of the microphone output voltage at the measurement, and the reference frequency;

$\frac{p(f)}{p_{\text{ref}}}$ is the ratio of the electrostatic pressure at the measurement, and the reference frequency;

$\frac{M_{\text{a}}(f)}{M_{\text{a,ref}}}$ is the electrostatic actuator response (linear unit).

Replacement of the above sound pressure parameters with the expression given in Equation (4) and insertion of factors that account for deviations of the individual actuator dimensions and for the individual microphone impedance from their nominal values lead to Equation (C.2) that expresses the measured actuator response (in linear units) and is used for estimation of the uncertainty of the measured actuator response:

$$\frac{M_{\text{a}}(f)}{M_{\text{a,ref}}} = \frac{\varepsilon_{\text{gas,ref}}}{\varepsilon_{\text{gas}}(f)} \cdot \frac{a_{\text{ref}}}{a(f)} \cdot \frac{U_{0,\text{ref}}}{U_0(f)} \cdot \frac{u_{\text{ref}}}{u(f)} \cdot \frac{d^2(f)}{d_{\text{ref}}^2} \cdot \frac{u_{\text{out}}(f)}{u_{\text{out,ref}}} \cdot \frac{D_{\text{act}}(f)}{D_{\text{act,ref}}} \cdot \frac{D_{\text{mic}}(f)}{D_{\text{mic,ref}}} \quad (\text{C.2})$$

where

$\frac{\varepsilon_{\text{gas,ref}}}{\varepsilon_{\text{gas}}(f)}$	is the ratio between dielectric constant of ambient gas at the reference, and the measurement frequency;
$\frac{a_{\text{ref}}}{a(f)}$	is the ratio between actuator-diaphragm area ratio at the reference, and the measurement frequency;
$\frac{U_{0,\text{ref}}}{U_0(f)}$	is the ratio between d.c. voltage applied between actuator and microphone diaphragm at the reference, and the measurement frequency;
$\frac{u_{\text{ref}}}{u(f)}$	is the ratio between r.m.s. value of a.c. voltage applied between actuator and microphone diaphragm at the reference, and the measurement frequency;
$\frac{d(f)}{d_{\text{ref}}}$	is the ratio between actuator-diaphragm distance at the measurement, and the reference frequency;
$\frac{D_{\text{act}}(f)}{D_{\text{act,ref}}}$	is the deviation from the nominal behaviour of an individual actuator in respect of the ratio between the actuator pressure at the measurement, and the reference frequency;
$\frac{D_{\text{mic}}(f)}{D_{\text{mic,ref}}}$	is the deviation from the nominal response caused by the influence of the diaphragm impedance of an individual microphone, in the actuator response at the measurement, and the reference frequency.

For this example the figures are just given for a single frequency. In practice the calculation is to be repeated for each frequency used, or at selected representative frequencies where a continuous frequency response is determined. The uncertainty reported should be based on the standard uncertainty multiplied with coverage factor of 2, thus providing a level of confidence of approximate 95 %.

C.3 Combined and expanded uncertainties

The combined standard uncertainty is found as the square root of the sum of squares of each standard uncertainty, which results in 0,068 dB for the example in Table C.1 (a strict calculation requires each component to be converted from logarithmic to linear form before doing the calculation, but as the values are quite small, the results would be essentially the same). The expanded uncertainty with a coverage factor of 2 is then 0,14 dB.

Table C.1 – Uncertainties

No.	Uncertainty component	Subclause of standard	Comments	Standard Uncertainty dB
1	$\frac{\varepsilon_{\text{gas,ref}}}{\varepsilon_{\text{gas}}(f)}$	5.2	The dielectric constant is assumed to be like that of air and constant during the measurement	0,00
2	$\frac{a_{\text{ref}}}{a(f)}$	5.2	The ratio between actuator and diaphragm areas is constant during the measurement	0,00
3	$\frac{U_{0,\text{ref}}}{U_0(f)}$	5.2 8.1.2	The actuator d.c. voltage is assumed to be constant during the measurement and to differ by less than 10 % from the specified value	0,01 ^a
4	$\frac{u_{\text{ref}}}{u(f)}$	5.2	The actuator a.c. voltage variation with frequency is accounted for as part of the frequency response of the measurement system; see point 8 below.	0,00
5	$\frac{d(f)}{d_{\text{ref}}}$	5.2	The actuator to diaphragm distance might change due to rattling during the measurement. This is accounted for under measurement reproducibility; see point 8 below.	0,00
6	$\frac{D_{\text{act}}(f)}{D_{\text{act,ref}}}$	7.2 7.3	Uncertainty related to repeatability of measurements with an individual actuator is accounted for under point 8 below. The stated value accounts for lack of uniformity between actuators.	0,03
7	$\frac{D_{\text{mic}}(f)}{D_{\text{mic,ref}}}$	7.4	Spread of diaphragm impedance within a model of microphone results in a lack of uniformity of the difference between actuator and pressure responses. The stated value is corrected for random errors of both pressure and actuator response measurements	0,04 ^b
8	$\frac{u_{\text{out}}(f)}{u_{\text{out,ref}}}$	8.2.2	Deviation from constant frequency response of measurement system	0,02
		8.2.3	Cross-talk within measurement system	0,01 ^c
		8.2.4	Inherent electrical and ambient acoustic noise	0,01 ^c
		8.2.5	Distortion of equivalent sound pressure produced by the actuator	0,01
		8.2.6	Deviation from radiation impedance in an ideal environment having no reflections	0,02
		8.2.7	Statistically determined measurement reproducibility	0,03
a	In general the influence of this parameter decreases with microphone sensitivity			
b	In general the influence of this parameter decreases with microphone sensitivity. Due to dominance of this parameter in the measurement uncertainty, it is recommended the influence be estimated from diaphragm and radiation impedance considerations, especially for low-sensitivity microphones.			
c	In general the influence of this parameter increases with decreasing microphone sensitivity. Large influence may occur due to cross-talk in case of low microphone sensitivity and high frequency.			

Annex D
(informative)

**Difference between free-field-, pressure- and actuator responses
for typical models of measurement microphones**

The graphs of Figures D.1 to D.4 give examples of the differences between the measured actuator response and the various field-specific frequency responses for typical measurement microphones. The graphs are given to demonstrate the order of magnitudes to be expected. Readings taken from the graphs should not be applied to any measurements.

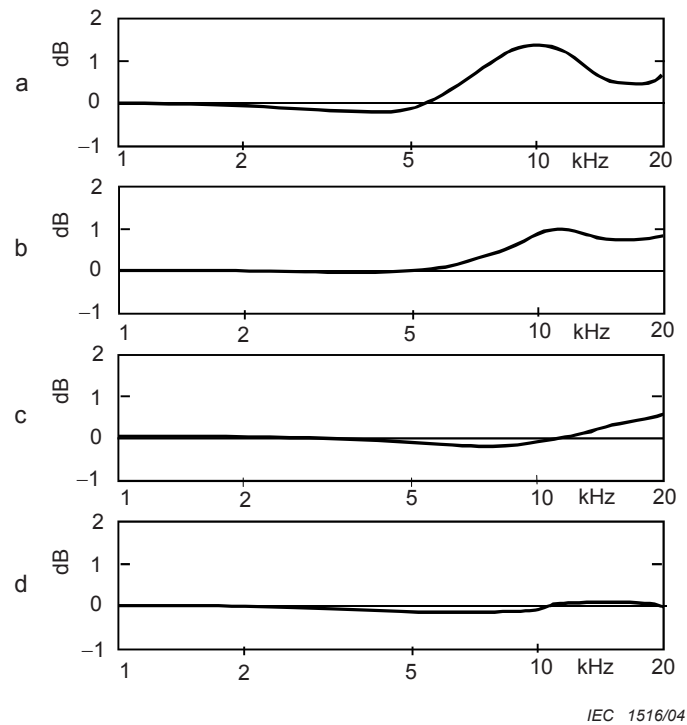

NOTE The graphs illustrate the order of magnitude only and should not be applied as corrections.

Figure D.1 – Examples of differences between relative pressure and actuator frequency responses for four different type of measurement microphone: WS1P (a), WS1F (b) of nominal sensitivities -26 dB re 1V/Pa, WS2P (c) and WS2F (d) of nominal sensitivities -38 dB re 1V/Pa

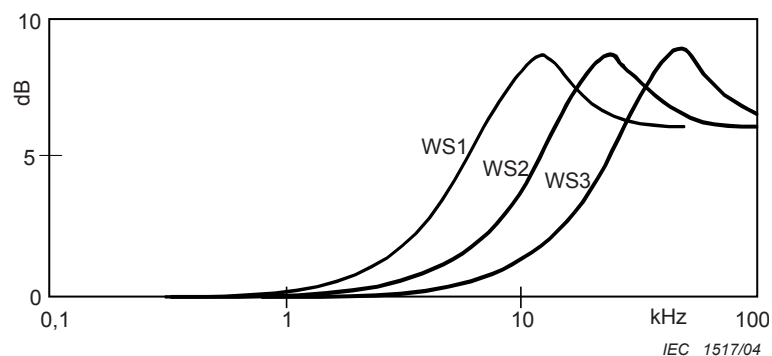

NOTE The graphs illustrate the order of magnitude only and should not be applied as corrections.

Figure D.2 – Examples of differences between relative free-field and actuator frequency responses for type WS1, WS2 and WS3 microphones when used without protection grids

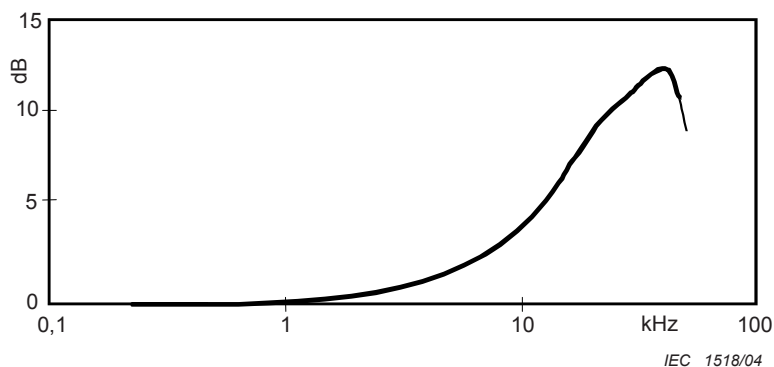

NOTE The graph illustrates the order of magnitude only and should not be applied as corrections.

Figure D.3 – Example of model dependent difference between relative free field and actuator frequency responses for a type WS2 microphone when used with its protection grid

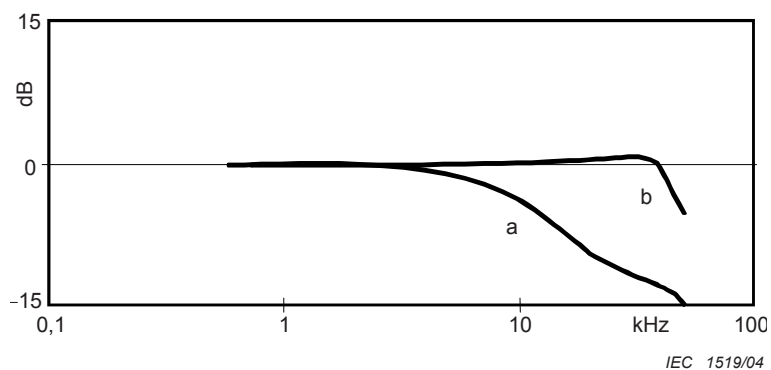

NOTE The graphs illustrate the order of magnitude only and should not be considered the free-field response of any given microphone model.

Figure D.4 – Example on the determination of a relative free-field frequency response b) by adding the model dependent free-field to actuator difference as shown in Figure D.3 to the electrostatic actuator response of a microphone a)

Annex ZA (normative)

Normative references to international publications with their corresponding European publications

The following referenced documents are indispensable for the application of this document. For dated references, only the edition cited applies. For undated references, the latest edition of the referenced document (including any amendments) applies.

NOTE Where an international publication has been modified by common modifications, indicated by (mod), the relevant EN/HD applies.

<u>Publication</u>	<u>Year</u>	<u>Title</u>	<u>EN/HD</u>	<u>Year</u>
IEC 61094-1	- ¹⁾	Measurement microphones Part 1: Specifications for laboratory standard microphones	EN 61094-1	2000 ²⁾
IEC 61094-2	- ¹⁾	Part 2: Primary method for pressure calibration of laboratory standard microphones by the reciprocity technique	EN 61094-2	1993 ²⁾
IEC 61094-3	- ¹⁾	Part 3: Primary method for free-field calibration of laboratory standard microphones by the reciprocity technique	EN 61094-3	1995 ²⁾
IEC 61094-5	- ¹⁾	Part 5: Methods for pressure calibration of working standard microphones by comparison	EN 61094-5	2001 ²⁾
ISO/IEC Guide Express	1995	Guide to the expression of uncertainty in measurement (GUM)	-	-

1) Undated reference.

2) Valid edition at date of issue.

BSI — British Standards Institution

BSI is the independent national body responsible for preparing British Standards. It presents the UK view on standards in Europe and at the international level. It is incorporated by Royal Charter.

Revisions

British Standards are updated by amendment or revision. Users of British Standards should make sure that they possess the latest amendments or editions.

It is the constant aim of BSI to improve the quality of our products and services. We would be grateful if anyone finding an inaccuracy or ambiguity while using this British Standard would inform the Secretary of the technical committee responsible, the identity of which can be found on the inside front cover.
Tel: +44 (0)20 8996 9000. Fax: +44 (0)20 8996 7400.

BSI offers members an individual updating service called PLUS which ensures that subscribers automatically receive the latest editions of standards.

Buying standards

Orders for all BSI, international and foreign standards publications should be addressed to Customer Services. Tel: +44 (0)20 8996 9001.
Fax: +44 (0)20 8996 7001. Email: orders@bsi-global.com. Standards are also available from the BSI website at <http://www.bsi-global.com>.

In response to orders for international standards, it is BSI policy to supply the BSI implementation of those that have been published as British Standards, unless otherwise requested.

Information on standards

BSI provides a wide range of information on national, European and international standards through its Library and its Technical Help to Exporters Service. Various BSI electronic information services are also available which give details on all its products and services. Contact the Information Centre.
Tel: +44 (0)20 8996 7111. Fax: +44 (0)20 8996 7048. Email: info@bsi-global.com.

Subscribing members of BSI are kept up to date with standards developments and receive substantial discounts on the purchase price of standards. For details of these and other benefits contact Membership Administration.
Tel: +44 (0)20 8996 7002. Fax: +44 (0)20 8996 7001.
Email: membership@bsi-global.com.

Information regarding online access to British Standards via British Standards Online can be found at <http://www.bsi-global.com/bsonline>.

Further information about BSI is available on the BSI website at <http://www.bsi-global.com>.

Copyright

Copyright subsists in all BSI publications. BSI also holds the copyright, in the UK, of the publications of the international standardization bodies. Except as permitted under the Copyright, Designs and Patents Act 1988 no extract may be reproduced, stored in a retrieval system or transmitted in any form or by any means – electronic, photocopying, recording or otherwise – without prior written permission from BSI.

This does not preclude the free use, in the course of implementing the standard, of necessary details such as symbols, and size, type or grade designations. If these details are to be used for any other purpose than implementation then the prior written permission of BSI must be obtained.

Details and advice can be obtained from the Copyright & Licensing Manager.
Tel: +44 (0)20 8996 7070. Fax: +44 (0)20 8996 7553.
Email: copyright@bsi-global.com.