

BS EN 60974-8:2009



BSI British Standards

Arc welding equipment —

Part 8: Gas consoles for welding and plasma cutting systems

NO COPYING WITHOUT BSI PERMISSION EXCEPT AS PERMITTED BY COPYRIGHT LAW

raising standards worldwide™

BSI
British Standards

National foreword

This British Standard is the UK implementation of EN 60974-8:2009. It is identical to IEC 60974-8:2009. It supersedes BS EN 60974-8:2004 which is withdrawn.

The UK participation in its preparation was entrusted to Technical Committee WEE/6, Electric arc welding equipment.

A list of organizations represented on this committee can be obtained on request to its secretary.

This publication does not purport to include all the necessary provisions of a contract. Users are responsible for its correct application.

© BSI 2009

ISBN 978 0 580 58740 5

ICS 25.160.30

Compliance with a British Standard cannot confer immunity from legal obligations.

This British Standard was published under the authority of the Standards Policy and Strategy Committee on 30 September 2009

Amendments issued since publication

Amd. No.	Date	Text affected
-----------------	-------------	----------------------

English version

**Arc welding equipment -
Part 8: Gas consoles for welding
and plasma cutting systems
(IEC 60974-8:2009)**

Matériel de soudage à l'arc -
Partie 8: Consoles de gaz pour soudage
et systèmes de coupage plasma
(CEI 60974-8:2009)

Lichtbogenschweißeinrichtungen -
Teil 8: Gaskonsolen für
Schweiß- und Plasmaschneidsysteme
(IEC 60974-8:2009)

This European Standard was approved by CENELEC on 2009-03-01. CENELEC members are bound to comply with the CEN/CENELEC Internal Regulations which stipulate the conditions for giving this European Standard the status of a national standard without any alteration.

Up-to-date lists and bibliographical references concerning such national standards may be obtained on application to the Central Secretariat or to any CENELEC member.

This European Standard exists in three official versions (English, French, German). A version in any other language made by translation under the responsibility of a CENELEC member into its own language and notified to the Central Secretariat has the same status as the official versions.

CENELEC members are the national electrotechnical committees of Austria, Belgium, Bulgaria, Cyprus, the Czech Republic, Denmark, Estonia, Finland, France, Germany, Greece, Hungary, Iceland, Ireland, Italy, Latvia, Lithuania, Luxembourg, Malta, the Netherlands, Norway, Poland, Portugal, Romania, Slovakia, Slovenia, Spain, Sweden, Switzerland and the United Kingdom.

CENELEC

European Committee for Electrotechnical Standardization
Comité Européen de Normalisation Electrotechnique
Europäisches Komitee für Elektrotechnische Normung

Central Secretariat: avenue Marnix 17, B - 1000 Brussels

Foreword

The text of document 26/381/CDV, future edition 2 of IEC 60974-8, prepared by IEC TC 26, Electric welding, was submitted to the IEC-CENELEC parallel vote and was approved by CENELEC as EN 60974-8 on 2009-03-01.

This European Standard supersedes EN 60974-8:2004.

The significant changes with respect to EN 60974-8:2004 are the following:

- removal of intrinsically safe design;
- introduction of gas mixing function;
- new informative rating plate layout;
- induced changes due to publication of EN 60974-1:2005.

This standard is to be used in conjunction with EN 60974-1.

The following dates were fixed:

- latest date by which the EN has to be implemented
at national level by publication of an identical
national standard or by endorsement (dop) 2009-12-01
- latest date by which the national standards conflicting
with the EN have to be withdrawn (dow) 2012-03-01

Annex ZA has been added by CENELEC.

Endorsement notice

The text of the International Standard IEC 60974-8:2009 was approved by CENELEC as a European Standard without any modification.

In the official version, for Bibliography, the following notes have to be added for the standards indicated:

IEC 60204-1	NOTE	Harmonized as EN 60204-1:2006 (modified).
IEC 60664-1	NOTE	Harmonized as EN 60664-1:2007 (not modified).
IEC 60974-2	NOTE	Harmonized as EN 60974-2:2008 (not modified).
IEC 60974-3	NOTE	Harmonized as EN 60974-3:2007 (not modified).
IEC 60974-7	NOTE	Harmonized as EN 60974-7:2005 (not modified).
IEC 61010-1	NOTE	Harmonized as EN 61010-1:2001 (not modified).

Annex ZA (normative)

Normative references to international publications with their corresponding European publications

The following referenced documents are indispensable for the application of this document. For dated references, only the edition cited applies. For undated references, the latest edition of the referenced document (including any amendments) applies.

NOTE When an international publication has been modified by common modifications, indicated by (mod), the relevant EN/HD applies.

<u>Publication</u>	<u>Year</u>	<u>Title</u>	<u>EN/HD</u>	<u>Year</u>
IEC 60050-151	- ¹⁾	International Electrotechnical Vocabulary (IEV) - Part 151: Electrical and magnetic devices	-	-
IEC 60529	- ¹⁾	Degrees of protection provided by enclosures (IP Code)	EN 60529 + corr. May	1991 ²⁾ 1993
IEC 60974-1	2005	Arc welding equipment - Part 1: Welding power sources	EN 60974-1	2005

¹⁾ Undated reference.

²⁾ Valid edition at date of issue.

CONTENTS

1	Scope	6
2	Normative references	6
3	Terms and definitions	6
4	Environmental conditions	7
5	Tests	7
5.1	Test conditions	7
5.2	Measuring instruments	7
5.3	Conformity of components	7
5.4	Type tests	7
5.5	Routine tests	8
5.5.1	External gas console	8
5.5.2	Internal gas console	8
6	Protection against electric shock	8
6.1	Insulation	8
6.2	Protection against electric shock in normal service (direct contact)	8
6.2.1	Protection provided by the enclosure	8
6.2.2	Capacitors	8
6.3	Protection against electric shock in case of a fault condition (indirect contact)	8
7	Thermal requirements	9
7.1	Heating test	9
7.2	Maximum temperature	9
8	Connections for plasma cutting torches	9
9	Mechanical requirements	9
9.1	Protection against fire or explosion	9
9.2	Gas line purging	9
9.3	Enclosure	10
9.3.1	Design requirements	10
9.3.2	Enclosure purging	10
9.3.3	Safe design of gas console	11
9.3.4	Open structure	11
9.3.5	Solid filled enclosure	11
9.4	External gas console	11
9.5	Internal gas console	12
10	Gas lines	12
10.1	Gas hoses and tubing	12
10.2	Gas fittings	12
10.3	Leak test	12
11	Control circuits	13
12	Rating plate	13
12.1	External gas console	13
12.2	Internal gas console	13
13	Instructions and markings	14
13.1	Instructions	14
13.2	Marking	14

Annex A (informative) Mechanized plasma system diagram 15

Annex B (informative) Example of a rating plate layout 16

Bibliography..... 17

Figure A.1 – Example of a mechanized plasma system 15

Figure B.1 – Principle of a rating plate 16

Table 1 – Colour coding and marking 12

ARC WELDING EQUIPMENT –

Part 8: Gas consoles for welding and plasma cutting systems

1 Scope

This part of IEC 60974 specifies safety and performance requirements for gas consoles intended to be used with combustible gases or oxygen. These gas consoles are designed to supply gases for use in arc welding, plasma cutting, gouging and allied processes in non-explosive atmospheres.

The gas console can be external or internal to the power source enclosure. In the latter case, this standard also applies to the power source.

NOTE See Annex A for mechanised plasma system diagram.

2 Normative references

The following referenced documents are indispensable for the application of this document. For dated references, only the edition cited applies. For undated references, the latest edition of the referenced document (including any amendments) applies.

IEC 60050-151, *International Electrotechnical Vocabulary – Part 151: Electrical and magnetic devices*

IEC 60529, *Degrees of protection provided by enclosures (IP Code)*

IEC 60974-1:2005, *Arc welding equipment – Part 1: Welding power sources*

3 Terms and definitions

For the purposes of this document, the following terms and definitions, as well as those of IEC 60050-151 and IEC 60974-1, apply.

3.1

gas console

device for gas-flow routing, mixing or both that contains electrical apparatus in a single or multiple enclosure, or open structure

3.2

lower explosion limit

LEL

concentration of flammable gas or vapour in air, below which the gas atmosphere is not explosive

[IEV 426-02-09, modified] [1]¹

¹ Figures in square brackets refer to the bibliography.

3.3
lower flammability limit
LFL

minimum concentration of combustible gas in a mixture where a combustion can be ignited by an ignition source

3.4
upper explosion limit
UEL

concentration of flammable gas or vapour in air, above which the gas atmosphere is not explosive

[IEV 426-02-10, modified]

3.5
upper flammability limit
UFL

maximum concentration of combustible gas in a mixture where a combustion can be ignited by an ignition source

3.6
external gas console

gas console not incorporated in a power source

3.7
internal gas console

gas console incorporated in a power source

3.8
single-fault condition

condition in which one means for protection against hazard is defective

NOTE If a single-fault condition results unavoidably in another single-fault condition, the two failures are considered as one single-fault condition.

[IEC 61010-1, definition 3.5.11, modified] [7]

4 Environmental conditions

As specified in Clause 4 of IEC 60974-1.

5 Tests

5.1 Test conditions

As specified in 5.1 of IEC 60974-1.

5.2 Measuring instruments

As specified in 5.2 of IEC 60974-1.

5.3 Conformity of components

As specified in 5.3 of IEC 60974-1.

5.4 Type tests

As specified in 5.4 of IEC 60974-1.

The other tests included in this standard may be carried out in any convenient sequence.

5.5 Routine tests

5.5.1 External gas console

All routine tests shall be carried out on each external gas console in the following sequence:

- a) general visual inspection, see 3.7 of IEC 60974-1;
- b) continuity of protective circuit, see 10.4.2 of IEC 60974-1;
- c) dielectric strength, see 6.1.5 of IEC 60974-1;
- d) leak test, see 10.3;
- e) general visual inspection, see 3.7 of IEC 60974-1.

5.5.2 Internal gas console

All routine tests, as specified in 5.5 of IEC 60974-1, shall be carried out on each internal gas console, with the following addition:

- g) leak test, see 10.3.

6 Protection against electric shock

6.1 Insulation

As specified in 6.1 of IEC 60974-1, with the following exception:

Printed circuit boards shall be enclosed, coated, or encapsulated.

6.2 Protection against electric shock in normal service (direct contact)

6.2.1 Protection provided by the enclosure

The minimum degree of protection for gas consoles shall be IP21S in accordance with IEC 60529.

Conformity shall be checked by

- a) *applying the articulated finger and ball, as specified in IEC 60529, to any openings and ensuring it does not contact any hazardous parts; and*
- b) *verifying that immediately after the water test, as specified in IEC 60529, the unit satisfies insulation resistance and the dielectric strength tests and is able to operate.*

No power is applied to the unit while performing these tests.

6.2.2 Capacitors

As specified in 6.2.2 of IEC 60974-1.

6.3 Protection against electric shock in case of a fault condition (indirect contact)

As specified in 6.3 of IEC 60974-1.

7 Thermal requirements

7.1 Heating test

As specified in 7.1 of IEC 60974-1.

For an external gas console, only the relevant tests are performed.

7.2 Maximum temperature

The temperature at any point shall not exceed the ignition temperature of any combustible gas intended to be used in the gas console.

Conformity shall be checked by operating the gas console as specified by the manufacturer

- a) *with the combinations of gas(es) and flow rates which creates the worst-case condition, as specified by the manufacturer;*
- b) *with the cooling liquid as specified by the manufacturer.*

8 Connections for plasma cutting torches

As specified in 11.4.6 of IEC 60974-1, where the torch connects to the gas console.

9 Mechanical requirements

As specified in Clause 14 of IEC 60974-1, with the following additions.

9.1 Protection against fire or explosion

The gas console shall be designed to prevent fire or explosion under normal operating conditions and under a single-fault condition (for example, defective valve, hose, etc.).

Where a gas console uses a combustible gas, any circuit, subassembly, or component shall not be capable of creating temperatures or a spark with sufficient energy to cause an ignition.

Where a gas console uses a combustible gas in a mixture, the mixture shall not be included within flammability limit that is defined by LFL and UFL.

Conformity shall be checked by

- a) *design evaluation and calculations of the circuits, subassembly, or component verification;*
or
- b) *applying a fault (for example, open circuit, short circuit, and/or restriction of movement) to the circuits, subassembly, or component until an event occurs (for example, a spark which does not cause ignition, fuse opens, unit shuts down, etc.) or a steady-state temperature is achieved.*

9.2 Gas line purging

The gas console shall have a means to purge gas lines when changing to a different type of gas (for example, oxidizing or oxygen containing to combustible) to reduce the risk of fire or explosion. In some cases, a small amount of combustible gas or oxygen may accumulate in the torch. This volume shall be small enough so that no risk can result.

The purging shall occur after each change in gas routing or when the previous gas routing is unknown.

NOTE 1 A means of accomplishing this can be by purging the lines with a sufficient volume of an inert gas.

NOTE 2 When a risk of fire or explosion exists in the gas lines due to changing gas, the purging can be performed with the following pressure cycle:

1. reduce the pressure of the gas console circuit to atmosphere pressure;
2. purge the gas console circuit with the purging gas;
3. increase the pressure to the maximum pressure of purging gas;
4. reduce the pressure of the gas console circuit to atmosphere pressure.

Conformity shall be checked by risk analysis and the following test.

The gas lines, when installed with all devices (valves, fittings, etc.) shall be filled with a combustible gas and measured with a gas detector. Immediately after, the gas lines shall be purged according to the instruction manual. Once purging has been completed, the contents of the gas lines shall be measured with the gas detector to ensure that the lines have been purged to a level lower than the lower flammability level (LFL) of the gas. If more than one combustible gas is used, the test shall be repeated for each combustible gas.

9.3 Enclosure

9.3.1 Design requirements

The gas console (external or internal) shall be designed to withstand or prevent an explosion. This shall be accomplished by complying with at least one of the requirements in 9.3.2 through 9.3.4.

NOTE All tests described below are dangerous, and it is recommended that they are performed by qualified personnel.

9.3.2 Enclosure purging

Purging means typically include positive pressure of an inert gas and forced ventilation (e.g. use of a non-arcing fan). Any automatic means to purge the gas console enclosure of combustible gases shall be activated before other electrical devices are energized.

Where a fan or other device is used for purging, a malfunction shall be indicated and the system shall be prevented from continuing to operate.

After purging, the level of combustible gas shall not exceed the lower explosion level (LEL).

Conformity shall be checked in a draught-free environment by a) or b) below.

- a) *Simulate a continuous gas leak inside the enclosure equal to the maximum flow rate and pressure as specified by the manufacturer. Monitor and adjust the gas in the enclosure until saturation or stabilization occurs. Activate the purging device(s) and monitor the gas to ensure it reaches the LEL before a potential ignition source is energized. Repeat for each type of combustible gas used.*
- b) *Place a simulated arcing device inside the purged enclosure. Monitor and adjust the gas in the enclosure until saturation or stabilization occurs. Operate all purging means and initiate start-up sequence. Energize the arcing device to simulate the electronics start-up, and operate continuously ensuring that no ignition occurs. Repeat for each type of combustible gas used.*

NOTE 1 A safe level of gas is 50 % of the LEL.

NOTE 2 The leak rate needs to be considered when performing these tests.

9.3.3 Safe design of gas console

9.3.3.1 Prevention of ignition

The gas console shall be designed to prevent an ignition caused by a gas leak in the enclosure.

Conformity shall be checked by completing the following test.

- a) *Place the energized equipment, i.e. the external gas console or the power source with internal gas console, in a bag (or similar).*
- b) *Simulate a gas leak inside the equipment to create an internal explosive atmosphere.*
- c) *Monitor the mixture until it is halfway between the LEL and the UEL of the gas.*
- d) *Operate the gas console for a period of at least 1 h, during which all components capable of causing ignition are cycled at least 100 times.*
- e) *Verify that no ignition occurred during the operating period.*
- f) *Ignite the bag (or similar) to confirm that a flammable mixture was present.*

9.3.3.2 Integrity of the enclosure

The enclosure, i.e. the external gas console or the power source with internal gas console, shall withstand an explosion without degradation of the protective continuity circuit.

Conformity shall be checked by completing the following test.

- a) *Place the non-energized equipment, i.e. the external gas console or the power source with internal gas console, in a bag (or similar).*
- b) *Simulate a gas leak inside the equipment to create an internal explosive atmosphere.*
- c) *Monitor the mixture until it is halfway between the LEL and the UEL of the gas.*
- d) *Ignite the flammable mixture using an arcing device installed in the equipment to create an explosion.*
- e) *Verify that there was no flying debris.*
- f) *Verify there is no contact with live hazardous parts using the jointed test finger specified in IEC 60529.*
- g) *Verify the continuity of the protective circuit by visual inspection and measurement.*

9.3.4 Open structure

An open-structure gas console designed with no enclosure or a partial enclosure that cannot accumulate a combustible mixture and cause an explosion shall be considered safe.

Conformity shall be checked by design review.

9.3.5 Solid filled enclosure

A gas console designed with an enclosure that does not contain any empty volume that can accumulate oxygen or a combustible mixture shall be considered safe.

Conformity shall be checked by design review.

9.4 External gas console

Where combustible gases are used, the external gas console shall only enclose the electric and non-electric apparatus (for example, electromagnetic valves, metering devices, flow meters, control circuits) required to route gases to the torch.

Conformity shall be checked by visual inspection.

9.5 Internal gas console

Where combustible gases are used, the internal gas console gas lines and gas components shall be separated by a barrier from the power source's live components within the same enclosure. Gas console control circuits may be located on either side of the barrier.

Conformity shall be checked by visual inspection.

10 Gas lines

10.1 Gas hoses and tubing

Gas hoses and tubing shall be suitable for the application. Gas hoses and tubing shall be rated for the maximum pressure at the maximum rated temperature in accordance with the product ratings.

Supply gas hoses shall be properly colour-coded or marked as specified in Table 1. Where gas supply circuit conveys more than one type of gas, gas hoses and tubing need not be marked provided the design prevents misconnections.

Table 1 – Colour coding and marking

Gas	Colour of cover
Acetylene and other combustible gases (except LPG, MPS, natural gas, red methane)	Red
Oxygen	Blue
Air, nitrogen, argon, CO ₂	Black
LPG, MPS, natural gas, methane orange	Orange
All fuel gases (included in this table) red-orange	Red-orange
NOTE 1 The manufacturer should be consulted on the suitability of the hose for use with hydrogen or propylene.	
NOTE 2 This table is taken from ISO 3821. [8]	

Conformity shall be checked by visual inspection and the test given in 10.3.

10.2 Gas fittings

Supply gas fittings shall not be interchangeable (for example, size, thread type) to avoid mixing fuel gases with inert gases or oxygen/air.

Conformity shall be checked by visual inspection.

10.3 Leak test

Assemblies through which gas flows shall be capable of operating under the rated inlet pressure at the rated operating temperature, without a hazardous leak as specified by the manufacturer.

Conformity shall be checked by a test specified by the manufacturer to ensure a safe assembly.

NOTE Air or inert gas used for this test should not contain contaminants that could degrade components used with O₂.

11 Control circuits

Control circuits not connected to the welding circuit shall meet the following requirements.

- a) The operating voltage of control circuits shall not exceed 250 V.
- b) A transformer with separate windings shall be used for supplying the control circuits.
- c) Overvoltage protection shall be provided.
- d) Overcurrent protection shall be provided.
- e) Single-fault conditions that may impair safety shall be evaluated.
- f) Transformer secondary, except for SELV, circuits shall be grounded.
- g) Insulation of bundled conductors shall be rated to the highest voltage of any of the conductors.
- h) Software and logic circuits shall not affect safety negatively.
- i) Control circuits that leave the enclosure shall be isolated from the primary circuit by double or reinforced insulation.

NOTE 1 These requirements are based on IEC 60204-1[2].

Conformity shall be checked by measurement or analysis, as appropriate.

NOTE 2 Types of control circuits:

- a) control circuits that are internal to the welding/cutting equipment enclosure;
- b) control circuits intended for interface between the power source and peripheral equipment designed by the manufacturer;
- c) control circuits intended for interfacing between the power source and other types of ancillary equipment;
- d) control circuits intended for inside the gas console.

12 Rating plate

12.1 External gas console

As specified in Clause 15 of IEC 60974-1, with the following modifications (as applicable):

- a) type of gas(es) used;
- b) maximum inlet gas pressure;
- c) maximum gas flow rating for each gas.

See Annex B for an example of a rating plate layout that may be used for an external gas console.

12.2 Internal gas console

For a gas console within a welding power source enclosure, the rating of the welding power source specified in Clause 15 of IEC 60974-1, shall be used with the following additions:

- a) standard reference;
- b) type of gas(es) used;
- c) maximum inlet gas pressure;
- d) maximum gas flow rating for each gas.

13 Instructions and markings

Each gas console shall be delivered with instructions and markings.

13.1 Instructions

As specified in 17.1 of IEC 60974-1, with the following additions (as applicable):

- a) information for selection and connection of gas hoses and I/O cables;
- b) EMC information specific to installation and operation of equipment specified in this standard;
- c) information regarding gas purging (for example, after each change in gas routing);
- d) ventilation requirements for installation;
- e) gas flow rates and maximum pressures;
- f) information regarding the gas source (for example, purity);
- g) statement that flashback arrestors are required (unless not available for specific gases or required pressures) to prevent fire from propagating back to the gas supply;
- h) recommended life and replacement of internal flexible hoses for combustible gas and oxygen;
- i) information about contamination of oxygen lines;
- j) general information specific to installation and operation of equipment specified in this standard (e.g. torch location relative to gas console and its supply).

NOTE The torch used in arc welding, plasma cutting and gouging is an obvious source of ignition necessary for its intended function.

Conformity shall be checked by visual inspection.

13.2 Marking

As specified in 17.2 of IEC 60974-1, (as applicable) and with the following addition.

Each gas connection shall be legibly and indelibly marked. The gas connections shall be marked with the maximum pressure and the type(s) of gas(es).

Conformity shall be checked by visual inspection.

Annex A (informative)

Mechanized plasma system diagram

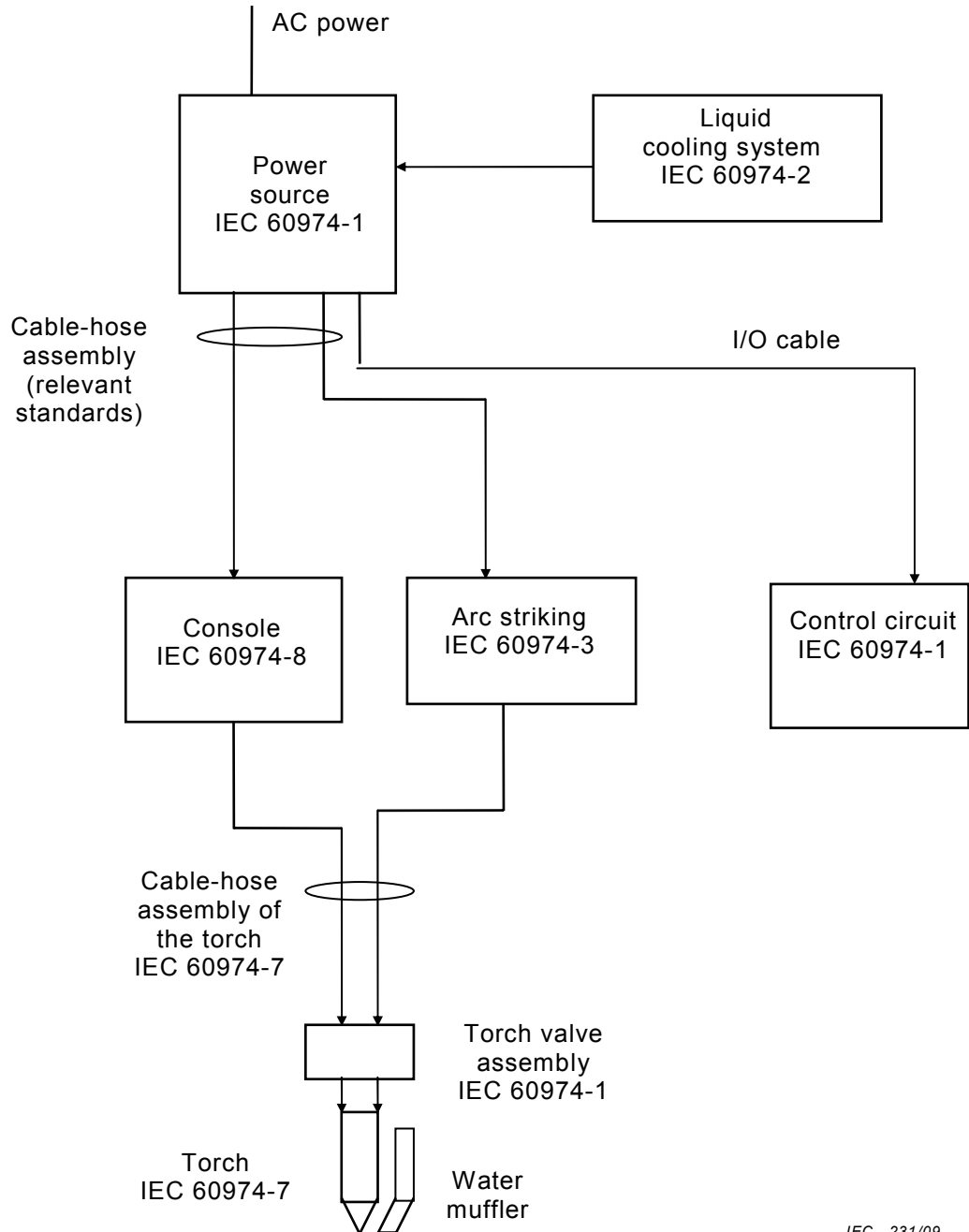



IEC 231/09

Figure A.1 – Example of a mechanized plasma system

Annex B
(informative)

Example of a rating plate layout

1		2
3		
	4	100 % DUTY CYCLE
 1~ 50 (60) Hz	U_1 5	I_{1max} 6
MAX. PRESSURE 7	MAX. INPUT FLOW RATE OF GAS 8	
9		

IEC 2879/03

Key

- 1 Name and address of the manufacturer or distributor or importer and optionally a trademark and the country of origin, if required
- 2 Reference to this standard conforming that the gas console complies with its requirements
- 3 Type (identification) as given by the manufacturer and traceability of design and manufacturing data, for example, serial number
- 4 Type of gases used (for example, H₂ or O₂)
- 5 Rated supply voltage: V
- 6 Rated maximum supply current: A
- 7 Maximum inlet gas pressure: MPa (bar)
- 8 Maximum gas flow rating for each gas: l/min
- 9 Degree of protection rating: IPXX

Figure B.1 – Principle of a rating plate

Bibliography

- [1] IEC 60050-426:2008, *International Electrotechnical Vocabulary – Part 426: Equipment for explosive atmospheres*
 - [2] IEC 60204-1, *Safety of machinery – Electrical equipment of machines – Part 1: General requirements*
 - [3] IEC 60664-1, *Insulation coordination for equipment within low-voltage systems – Part 1: Principles, requirements and tests*
 - [4] IEC 60974-2, *Arc welding equipment – Part 2: Liquid cooling system*
 - [5] IEC 60974-3, *Arc welding equipment – Part 3: Arc striking and stabilizing devices*
 - [6] IEC 60974-7, *Arc welding equipment – Part 7: Torches*
 - [7] IEC 61010-1:2001, *Safety requirements for electrical equipment for measurement, control, and laboratory use – Part 1: General requirements*
 - [8] ISO 3821, *Gas welding equipment – Rubber hoses for welding, cutting and allied processes*
 - [9] ISO 12170, *Gas welding equipment – Thermoplastic hoses for welding and allied processes*
-

British Standards Institution (BSI)

BSI is the independent national body responsible for preparing British Standards. It presents the UK view on standards in Europe and at the international level.

It is incorporated by Royal Charter.

Revisions

British Standards are updated by amendment or revision. Users of British Standards should make sure that they possess the latest amendments or editions.

It is the constant aim of BSI to improve the quality of our products and services. We would be grateful if anyone finding an inaccuracy or ambiguity while using this British Standard would inform the Secretary of the technical committee responsible, the identity of which can be found on the inside front cover.

Tel: +44 (0)20 8996 9000 Fax: +44 (0)20 8996 7400

BSI offers members an individual updating service called PLUS which ensures that subscribers automatically receive the latest editions of standards.

Buying standards

Orders for all BSI, international and foreign standards publications should be addressed to BSI Customer Services.

Tel: +44 (0)20 8996 9001 Fax: +44 (0)20 8996 7001
Email: orders@bsigroup.com

You may also buy directly using a debit/credit card from the BSI Shop on the website www.bsigroup.com/shop

In response to orders for international standards, it is BSI policy to supply the BSI implementation of those that have been published as British Standards, unless otherwise requested.

Information on standards

BSI provides a wide range of information on national, European and international standards through its Library.

Various BSI electronic information services are also available which give details on all its products and services. Contact the Information Centre.

Tel: +44 (0)20 8996 7111

Fax: +44 (0)20 8996 7048 Email: info@bsigroup.com

Subscribing members of BSI are kept up to date with standards developments and receive substantial discounts on the purchase price of standards. For details of these and other benefits contact Membership Administration.

Tel: +44 (0)20 8996 7002 Fax: +44 (0)20 8996 7001

Email: membership@bsigroup.com

Information regarding online access to British Standards via British Standards Online can be found at www.bsigroup.com/BSOL

Further information about BSI is available on the BSI website at www.bsigroup.com

Copyright

Copyright subsists in all BSI publications. BSI also holds the copyright, in the UK, of the publications of the international standardization bodies. Except as permitted under the Copyright, Designs and Patents Act 1988 no extract may be reproduced, stored in a retrieval system or transmitted in any form or by any means – electronic, photocopying, recording or otherwise – without prior written permission from BSI.

This does not preclude the free use, in the course of implementing the standard of necessary details such as symbols, and size, type or grade designations. If these details are to be used for any other purpose than implementation then the prior written permission of BSI must be obtained. Details and advice can be obtained from the Copyright & Licensing Manager.

Tel: +44 (0)20 8996 7070 Email: copyright@bsigroup.com

BSI Group Headquarters

389 Chiswick High Road London W4 4AL UK

Tel +44 (0)20 8996 9001

Fax +44 (0)20 8996 7001

www.bsigroup.com/standards

raising standards worldwide™

BSI
British Standards