

BS EN 60940:2015



BSI Standards Publication

**Guidance information on
the application of capacitors,
resistors, inductors and
complete filter units for
electromagnetic interference
suppression**

bsi.

...making excellence a habit.™

National foreword

This British Standard is the UK implementation of EN 60940:2015. It is identical to IEC 60940:2015.

The UK participation in its preparation was entrusted to Technical Committee EPL/40X, Capacitors and resistors for electronic equipment.

A list of organizations represented on this committee can be obtained on request to its secretary.

This publication does not purport to include all the necessary provisions of a contract. Users are responsible for its correct application.

© The British Standards Institution 2015.

Published by BSI Standards Limited 2015

ISBN 978 0 580 82519 4

ICS 33.100.01

Compliance with a British Standard cannot confer immunity from legal obligations.

This British Standard was published under the authority of the Standards Policy and Strategy Committee on 31 May 2015.

Amendments/corrigenda issued since publication

Date	Text affected
-------------	----------------------

EUROPEAN STANDARD

EN 60940

NORME EUROPÉENNE

EUROPÄISCHE NORM

May 2015

ICS 33.100

English Version

Guidance information on the application of capacitors, resistors,
inductors and complete filter units for electromagnetic
interference suppression
(IEC 60940:2015)

Guide d'emploi des condensateurs, résistances,
inductances et filtres complets d'antiparasitage
(IEC 60940:2015)

Grundlagen für die Anwendung von Kondensatoren,
Widerständen, Drosseln und vollständigen Filtereinheiten
zur Unterdrückung elektromagnetischer Störungen
(IEC 60940:2015)

This European Standard was approved by CENELEC on 2015-04-14. CENELEC members are bound to comply with the CEN/CENELEC Internal Regulations which stipulate the conditions for giving this European Standard the status of a national standard without any alteration.

Up-to-date lists and bibliographical references concerning such national standards may be obtained on application to the CEN-CENELEC Management Centre or to any CENELEC member.

This European Standard exists in three official versions (English, French, German). A version in any other language made by translation under the responsibility of a CENELEC member into its own language and notified to the CEN-CENELEC Management Centre has the same status as the official versions.

CENELEC members are the national electrotechnical committees of Austria, Belgium, Bulgaria, Croatia, Cyprus, the Czech Republic, Denmark, Estonia, Finland, Former Yugoslav Republic of Macedonia, France, Germany, Greece, Hungary, Iceland, Ireland, Italy, Latvia, Lithuania, Luxembourg, Malta, the Netherlands, Norway, Poland, Portugal, Romania, Slovakia, Slovenia, Spain, Sweden, Switzerland, Turkey and the United Kingdom.



European Committee for Electrotechnical Standardization
Comité Européen de Normalisation Electrotechnique
Europäisches Komitee für Elektrotechnische Normung

CEN-CENELEC Management Centre: Avenue Marnix 17, B-1000 Brussels

Foreword

The text of document 40/2337/FDIS, future edition 2 of IEC 60940, prepared by IEC/TC 40 "Capacitors and resistors for electronic equipment" was submitted to the IEC-CENELEC parallel vote and approved by CENELEC as EN 60940:2015.

The following dates are fixed:

- latest date by which the document has to be implemented at national level by publication of an identical national standard or by endorsement (dop) 2016-01-14
- latest date by which the national standards conflicting with the document have to be withdrawn (dow) 2018-04-14

Attention is drawn to the possibility that some of the elements of this document may be the subject of patent rights. CENELEC [and/or CEN] shall not be held responsible for identifying any or all such patent rights.

Endorsement notice

The text of the International Standard IEC 60940:2015 was approved by CENELEC as a European Standard without any modification.

In the official version, for Bibliography, the following notes have to be added for the standards indicated:

IEC 60068-2-78	NOTE	Harmonized as EN 60068-2-78.
IEC 60204-1	NOTE	Harmonized as EN 60204-1.
IEC 60384-14-1	NOTE	Harmonized as EN 60384-14-1.
IEC 60384-14-2	NOTE	Harmonized as EN 60384-14-2.
IEC 60384-14-3	NOTE	Harmonized as EN 60384-14-3.
IEC 60664-1	NOTE	Harmonized as EN 60664-1.
IEC 60938-1	NOTE	Harmonized as EN 60938-1.
IEC 60938-2	NOTE	Harmonized as EN 60938-2.
IEC 60938-2-1	NOTE	Harmonized as EN 60938-2-1.
IEC 60938-2-2	NOTE	Harmonized as EN 60938-2-2.
IEC 60939-1	NOTE	Harmonized as EN 60939-1.
IEC 60939-2	NOTE	Harmonized as EN 60939-2.
IEC 60939-2-1	NOTE	Harmonized as EN 60939-2-1.
IEC 60939-2-2	NOTE	Harmonized as EN 60939-2-2.
IEC 60950-1	NOTE	Harmonized as EN 60950-1.
IEC 62368-1	NOTE	Harmonized as EN 62368-1.
CISPR 11	NOTE	Harmonized as EN 55011.
CISPR 17	NOTE	Harmonized as EN 55017.

Annex ZA (normative)

Normative references to international publications with their corresponding European publications

The following documents, in whole or in part, are normatively referenced in this document and are indispensable for its application. For dated references, only the edition cited applies. For undated references, the latest edition of the referenced document (including any amendments) applies.

NOTE 1 When an International Publication has been modified by common modifications, indicated by (mod), the relevant EN/HD applies.

NOTE 2 Up-to-date information on the latest versions of the European Standards listed in this annex is available here: www.cenelec.eu

<u>Publication</u>	<u>Year</u>	<u>Title</u>	<u>EN/HD</u>	<u>Year</u>
IEC 60335-1	-	Household and similar electrical appliances - Safety - Part 1: General requirements	EN 60335-1	-
IEC 60384-14	-	Fixed capacitors for use in electronic equipment - Part 14: Sectional specification - Fixed capacitors for electromagnetic interference suppression and connection to the supply mains	EN 60384-14	-

CONTENTS

FOREWORD	3
1 Scope	5
2 Normative references	5
3 Electromagnetic and Radio frequency interference suppression (EMI/RFI)	5
3.1 General.....	5
3.2 Limits of interference	6
4 Classification of suppression components	6
4.1 Suppression components	6
4.2 Capacitors	8
4.3 Inductors.....	8
4.4 Filters	8
5 Choice of ratings for specific applications	8
5.1 Voltage	8
5.2 Current	9
5.3 Environmental classification (climatic category)	9
5.4 Insertion loss	9
6 Connection of suppression components.....	9
7 Safety aspects.....	10
7.1 Class X and Y capacitors	10
7.2 Leakage current.....	11
7.3 Mounting of radio interference suppression components in equipment and appliances	11
7.4 Electrical shock hazard protection testing	11
Bibliography.....	12
Figure 1 – Example use of suppression components in EMI filter	7

INTERNATIONAL ELECTROTECHNICAL COMMISSION

**GUIDANCE INFORMATION ON THE APPLICATION OF CAPACITORS,
RESISTORS, INDUCTORS AND COMPLETE FILTER UNITS FOR
ELECTROMAGNETIC INTERFERENCE SUPPRESSION**

FOREWORD

- 1) The International Electrotechnical Commission (IEC) is a worldwide organization for standardization comprising all national electrotechnical committees (IEC National Committees). The object of IEC is to promote international co-operation on all questions concerning standardization in the electrical and electronic fields. To this end and in addition to other activities, IEC publishes International Standards, Technical Specifications, Technical Reports, Publicly Available Specifications (PAS) and Guides (hereafter referred to as "IEC Publication(s)"). Their preparation is entrusted to technical committees; any IEC National Committee interested in the subject dealt with may participate in this preparatory work. International, governmental and non-governmental organizations liaising with the IEC also participate in this preparation. IEC collaborates closely with the International Organization for Standardization (ISO) in accordance with conditions determined by agreement between the two organizations.
- 2) The formal decisions or agreements of IEC on technical matters express, as nearly as possible, an international consensus of opinion on the relevant subjects since each technical committee has representation from all interested IEC National Committees.
- 3) IEC Publications have the form of recommendations for international use and are accepted by IEC National Committees in that sense. While all reasonable efforts are made to ensure that the technical content of IEC Publications is accurate, IEC cannot be held responsible for the way in which they are used or for any misinterpretation by any end user.
- 4) In order to promote international uniformity, IEC National Committees undertake to apply IEC Publications transparently to the maximum extent possible in their national and regional publications. Any divergence between any IEC Publication and the corresponding national or regional publication shall be clearly indicated in the latter.
- 5) IEC itself does not provide any attestation of conformity. Independent certification bodies provide conformity assessment services and, in some areas, access to IEC marks of conformity. IEC is not responsible for any services carried out by independent certification bodies.
- 6) All users should ensure that they have the latest edition of this publication.
- 7) No liability shall attach to IEC or its directors, employees, servants or agents including individual experts and members of its technical committees and IEC National Committees for any personal injury, property damage or other damage of any nature whatsoever, whether direct or indirect, or for costs (including legal fees) and expenses arising out of the publication, use of, or reliance upon, this IEC Publication or any other IEC Publications.
- 8) Attention is drawn to the Normative references cited in this publication. Use of the referenced publications is indispensable for the correct application of this publication.
- 9) Attention is drawn to the possibility that some of the elements of this IEC Publication may be the subject of patent rights. IEC shall not be held responsible for identifying any or all such patent rights.

International Standard IEC 60940 has been prepared by IEC technical committee 40: Capacitors and resistors for electronic equipment.

This second edition cancels and replaces the first edition published in 1988. This second edition is a result of maintenance activities related to the previous edition. All changes that have been agreed upon can be categorized as minor revisions.

The text of this standard is based on the following documents:

FDIS	Report on voting
40/2337/FDIS	40/2362/RVD

Full information on the voting for the approval of this standard can be found in the report on voting indicated in the above table.

This publication has been drafted in accordance with the ISO/IEC Directives, Part 2.

The committee has decided that the contents of this publication will remain unchanged until the stability date indicated on the IEC website under "<http://webstore.iec.ch>" in the data related to the specific publication. At this date, the publication will be

- reconfirmed,
- withdrawn,
- replaced by a revised edition, or
- amended.

GUIDANCE INFORMATION ON THE APPLICATION OF CAPACITORS, RESISTORS, INDUCTORS AND COMPLETE FILTER UNITS FOR ELECTROMAGNETIC INTERFERENCE SUPPRESSION

1 Scope

This international standard provides guidance applicable to information on application of capacitors, resistors, inductors, and complete filter units for electromagnetic interference suppression.

2 Normative references

The following documents, in whole or in part, are normatively referenced in this document and are indispensable for its application. For dated references, only the edition cited applies. For undated references, the latest edition of the referenced document (including any amendments) applies.

IEC 60335-1, *Household and similar electrical appliances – Safety – Part 1: General requirements*

IEC 60384-14, *Fixed capacitors for use in electronic equipment – Part 14: Sectional specification – Fixed capacitors for electromagnetic interference suppression and connection to the supply mains*

3 Electromagnetic and Radio frequency interference suppression (EMI/RFI)

3.1 General

Electromagnetic interference, EMI, is any electromagnetic emission or any electric or electronic disturbance which causes an undesirable response, malfunctioning or degradation in the performance of electrical equipment.

Radio frequency interference, RFI, is any electrical energy with content within the frequency range dedicated to radio frequency transmission.

Conducted RFI is most often found in the low frequency range from 150 kHz to 30 MHz.

Radiated RFI is most often found in the frequency range from 30 MHz to 10 GHz.

EMI or RFI propagate through conduction over signal and power lines and through radiation in free space.

Electrical machines and apparatus may generate electromagnetic interferences (EMI) which are fed back into power supply mains. These electromagnetic interferences may be picked up by apparatus connected to or placed close to the same power system up to a certain distance from the machine or apparatus.

The radio-frequency voltages may be generated both between conductors (phases) of the power system (symmetrical interference) and also between conductors (phases) and earth (asymmetrical interference). These voltages can cause electromagnetic radiation from the power lines.

Radio interference can be suppressed by providing a low impedance path for radio frequency currents close to the place where the radio frequency voltages are generated. This may be combined with a high impedance element which prevents the radio frequency currents from penetrating into the power supply system, but has no appreciable effect on the flow of power current.

3.2 Limits of interference

In various countries, mandatory limits are set to the radio-frequency in a given frequency range emanating from electrical machines and apparatus.

A survey of these limits is given in relevant EMC-standards such as CISPR 11.

Some electrical apparatus require for their operation a power-supply voltage free from radio-interference to a greater extent than that guaranteed by the requirements mentioned above. In these cases, similar measures should be taken at a place in the power supply system close to the place where the apparatus is connected. When the apparatus is shielded (or placed in a shielded room), interference suppression will generally be applied at each point where the power supply system enters the shielded enclosure.

4 Classification of suppression components

4.1 Suppression components

An example of use of suppression components in EMI filter is shown in Figure 1.

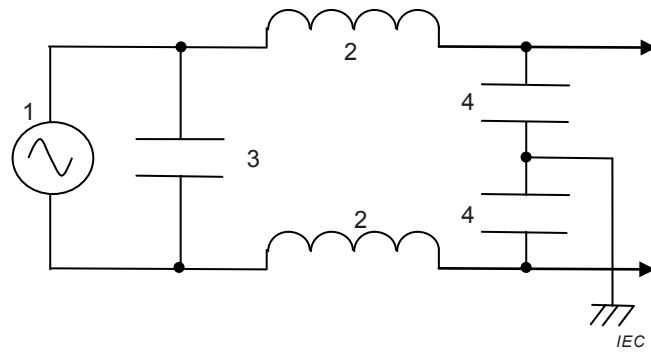

a) Single phase EMI filter

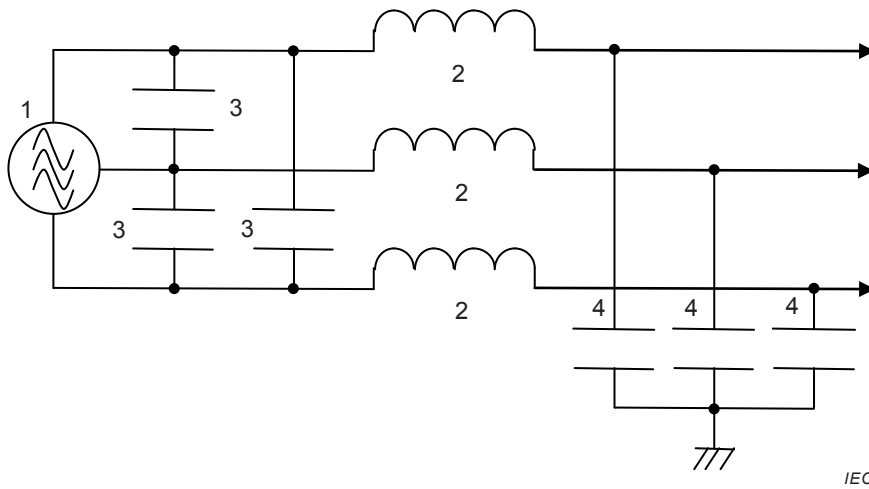

b) Three phase three wires EMI filter

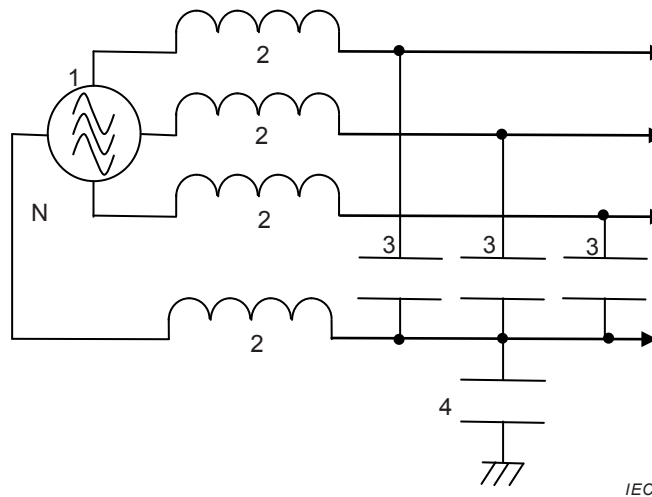

c) Three phase four wires EMI filter

Key

- 1 Mains
- 2 Inductor
- 3 X-capacitor
- 4 Y-capacitor
- N Neutral

Figure 1 – Example use of suppression components in EMI filter

4.2 Capacitors

Radio interference suppression capacitors may be divided into the following groups:

- a) Two-terminal capacitors, which can be connected to the machine, apparatus or supply system to provide for either symmetrical or asymmetrical interference suppression.
- b) Combinations of capacitors (either combinations of separate capacitors or multi-section capacitor the sections of which may be connected in a certain manner), which can be connected to the machine, apparatus or supply system to provide for both symmetrical and asymmetrical interference suppression.
- c) Lead-through capacitors (asymmetrical or symmetrical) or combinations thereof, in which one or more sets of terminations are interconnected by means of a conductor intended to carry the power supply current. These capacitors are especially suited to provide interference suppression at the place where the supply system phases through a shielded housing.
- d) Resistor-capacitor combinations consisting of a capacitor with the capacitor utilizing the resistance of the capacitor electrodes. RC combinations are often used for the suppression of switching surges.

4.3 Inductors

Radio interference suppression inductors may be divided into the following groups:

- a) Simple coils either with an air core or wound on a magnetic core. The UHF choke is an example of this type of inductor.
- b) Coils wound on a closed magnetic core. These inductors may have two or more coils wound on the same core, which is often of ferrite material. The windings are often arranged so that there is no resultant magnetization induced in the core due to the power current, when the inductor is known as current-compensated.
- c) Inductance, at high frequencies, may be obtained for suppression purposes by threading ferrite beads on to lead wires.
- d) Some core materials, especially ferrite materials, can be designed to introduce fairly high resistive losses at VHF and UHF, adding to the suppression obtained by the inductance of the coil.

4.4 Filters

Radio interference filters are construed from inductors and capacitors, sometimes with the addition of resistors, varistors, etc. Two different types may be distinguished:

- a) Filters constructed from approved components either as an unprotected assembly or with a simple protective casing. The approval testing of these filters can be simplified since it is not necessary to repeat the tests already carried out on the components.
- b) Filters constructed from components which are not approved, or which are constructed from capacitive, inductive or resistive elements all contained in housing. For such filters it is necessary to carry out a full range of qualification approval tests.

5 Choice of ratings for specific applications

5.1 Voltage

When selecting components for connection to a.c. mains, consideration shall be given to possible mains voltage fluctuations. When operation under high pulse conditions is required for capacitors connected across the mains, then class X1 capacitors should be used (see IEC 60384-14).

For d.c. components the rated voltage shall be the maximum which the component will encounter, unless there is a special test for behaviour under transient conditions.

5.2 Current

The rated current is the maximum which the component can carry at a temperature up to the rated temperature. Lower currents can be carried at higher temperature up to the upper category temperature. Higher currents may be carried if the component is fitted to a heat sink as specified by the manufacturer. The manufacturer may specify both a still air rated current and higher rated current when the component is used with a specified heat sink.

5.3 Environmental classification (climatic category)

This is comprised of three figures, e.g. (25/085/21). This indicates that the lower category temperature is $-25\text{ }^{\circ}\text{C}$, the upper category temperature $+85\text{ }^{\circ}\text{C}$ and the duration of the damp heat, steady state test is 21 days.

When the suppression component is mounted and working in the equipment the case temperature should not be outside the category temperature range under any conditions of operation.

The selection of the humidity classification depends on the environment in which the equipment is expected to work. 21 days is frequently chosen for domestic appliances, for example.

5.4 Insertion loss

The performance of a component or a filter is normally described by its insertion loss measured over a range of frequencies when terminated by fixed real impedances. In practice the filter is connected between the mains supply and the source of the interference, both of which have complex impedances which vary with frequency. As a consequence insertion loss curves can only be used as an indication of suppression performance, which can be determined decisively only by connecting the filter to the apparatus and then measuring the remaining interference.

The measurement of insertion loss is useful to check stability after environmental and endurance tests, and to compare filters of different construction, but since the effectiveness of a given suppressor may be determined without insertion loss measurements the manufacturer may not declare insertion loss figures.

Where insertion loss figures are declared, it is important that it should be carefully stated whether the test circuit is asymmetric or symmetric, what test method is used, what the values of the terminating impedances are and whether the component is carrying any power current during measurements.

NOTE Methods of Measurement of Suppression Characteristics are described in CISPR 17.

6 Connection of suppression components

Symmetrical interference suppression is effected by connecting a capacitor between phases of power supply (between phase and neutral for single-phase power supply).

Asymmetrical interference suppression on machines or apparatus is usually effected by connecting a capacitor from each phase (or phase and neutral) to earthed metallic parts or the frame, metallic housing etc., where this is not earthed.

The suppression will often be more effective if the electrical parts of the apparatus are completely in the metal shielding, asymmetrical interference suppression is usually effected by connecting a capacitor from each phase (or phase and neutral) to the shielding.

During operation, the capacitors are subjected to the supply mains voltage with a superimposed radio interference voltage. In many cases, the extra load caused by the radio-frequency voltage is not important, but in other cases an appreciable radio-frequency current through the capacitor may occur or high voltage peaks may be present. This must be taken into account when choosing the capacitor and a check should be made with the capacitor under its working conditions to make sure that its ratings are not exceeded.

The presence of inductance in the supply circuits in series with the capacitor may cause the voltage at power frequency applied to the capacitor to exceed the supply voltage.

For inductors using ferromagnetic cores, it is important to be aware of the possible loss of suppression caused by saturation of the core causing decrease of inductance. This saturation may be caused by peaks of load current or interference current, or continuous excessive load current. Unbalance of winding in current-compensated inductors will also contribute to the effect.

The effectiveness of interference suppression is a function of suppression component construction, mounting of the component in the machine or apparatus, the radio-frequency voltage spectrum generated by the machine or apparatus and of characteristics of the external circuit.

Due to the complexity of the problem it is not possible to estimate with sufficient accuracy from the radio-frequency characteristics of a component how effective it will be under various conditions.

On the other hand, components for use under similar conditions can be compared on the basis of their radio-frequency characteristics. For this purpose the resonance frequency measured under given conditions and the radio-frequency resistive at resonance may be of use. For these reasons it is not required that the radio-frequency characteristics be marked on the components nor has it been attempted to standardize certain values for these characteristics.

7 Safety aspects

7.1 Class X and Y capacitors

Radio interference suppression capacitors are divided into X- and Y- capacitors.

X-capacitors are intended to be connected across the line.

Y-capacitors are allowed to be connected between line and earth for mains voltages up to 500 V.

In a.c. applications, Y-capacitors can be substituted with two X-capacitors connected in series provided that the U_R of the X-capacitors are not less than the U_R of the Y-capacitor and that the filter withstands the voltage proof as required in IEC 60939 series. In case of Y1-capacitor substitution, the X-capacitors shall be X1-capacitors.

In DC-Filters with a rated voltage of 150 V d.c. or less, a Y2- and Y4-capacitor may be substituted by X-capacitor with a rated voltage 250 V d.c. or higher.

In the case of failure by short circuit of a class X-capacitor connected between phases (or between phase and neutral) no problem arises since the apparatus will be disconnected by means of the normal short-circuit protection of the mains supply. For such capacitors a voltage proof test level appropriate for general purpose capacitors is sufficient. Such capacitors are subdivided into class X1 and class X2 according to their ability to handle levels of peak pulse voltage (see IEC 60384-14). However in the case of failure by short

circuit of a class Y-capacitor connected between phase and an accessible metal part of the apparatus, the latter can become alive with a dangerous voltage. From an electrical shock hazard protection point of view the dielectric strength of these capacitors shall be at least equal to the required dielectric strength of the apparatus or system in which the capacitor will be used.

7.2 Leakage current

Earth leakage current is defined as “current flowing from the live parts of an installation to earth, in the absence of an insulation fault” (IEC 60050-442:1998, 442-01-24).

At operating temperature, the leakage current of the appliance shall not be excessive and its electric strength shall be adequate.

Limits are given in the relevant equipment standards such as IEC 60335-1, IEC 60204-1 or IEC 60950-1.

If the Leakage Current exceeds 3,5 mA (r.m.s.), a warning with similar wording shall be marked:

Warning
High Leakage Current
Earth Connection Essential
Before Connecting Supply

When choosing the capacitance of capacitors to be connected between live parts and accessible metal parts, these limits have to be taken into account, so that the appropriate limit for the whole equipment is not exceeded.

7.3 Mounting of radio interference suppression components in equipment and appliances

The creepage and clearance distances on the outside of the suppression component should be at least of the standard required for the appliance itself. The clearances quoted in IEC 60939-series are taken from IEC 60335-1 and apply to domestic applications. Other clearances may be appropriate in other types of equipment.

7.4 Electrical shock hazard protection testing

In the IEC 60938- and IEC 60939-series and in IEC 60384-14 separate test schedules are provided for tests where certification for electrical shock hazard protection only is to be carried out. No detail specification is permitted to reduce any of these requirements. The schedule of electrical shock hazard protection tests only is the appropriate one to be followed by a certifying test laboratory.

Bibliography

IEC 60050-442:1998, *International Electrotechnical Vocabulary – Part 442: Electrical accessories*

IEC 60068-2-78, *Environmental testing – Part 2-78: Tests – Test Cab: Damp heat, steady state*

IEC 60204-1, *Safety of machinery – Electrical equipment of machines – Part 1: General requirements*

IEC 60384-14-1, *Fixed capacitors for use in electronic equipment – Part 14-1: Blank detail specification: Fixed capacitors for electromagnetic interference suppression and connection to the supply mains – Assessment level D*

IEC 60384-14-2, *Fixed capacitors for use in electronic equipment – Part 14-2: Blank detail specification – Fixed capacitors for electromagnetic interference suppression and connection to the supply mains – Safety tests only*

IEC 60384-14-3, *Fixed capacitors for use in electronic equipment – Part 14-3: Blank detail specification – Fixed capacitors for electromagnetic interference suppression and connection to the supply mains – Assessment level DZ*

IEC 60664-1, *Insulation coordination for equipment within low-voltage systems – Part 1: Principles, requirements and tests*

IEC 60938-1, *Fixed inductors for electromagnetic interference suppression – Part 1: Generic specification*

IEC 60938-2, *Fixed inductors for electromagnetic interference suppression – Part 2: Sectional specification*

IEC 60938-2-1, *Fixed inductors for electromagnetic interference suppression – Part 2-1: Blank detail specification – Inductors for which safety tests are required – Assessment level D*

IEC 60938-2-2, *Fixed inductors for electromagnetic interference suppression – Part 2-2: Blank detail specification – Inductors for which safety tests are required (only)*

IEC 60939-1, *Passive filter units for electromagnetic interference suppression – Part 1: Generic specification*

IEC 60939-2, *Passive filter units for electromagnetic interference suppression – Part 2: Sectional specification – Passive filter units for which safety tests are appropriate – Test methods and general requirements*

IEC 60939-2-1, *Complete filter units for radio interference suppression – Part 2-1: Blank detail specification – Passive filter units for electromagnetic interference suppression – Filters for which safety tests are required (assessment level D/DZ)*

IEC 60939-2-2, *Complete filter units for radio interference suppression – Part 2-2: Blank detail specification – Passive filter units for electromagnetic interference suppression – Filters for which safety tests are required (safety tests only)*

IEC 60950-1, *Information technology equipment – Safety – Part 1: General requirements*

IEC 62368-1, *Audio/video, information and communication technology equipment – Part 1: Safety requirements*

CISPR 11, *Industrial, scientific and medical equipment – Radio-frequency disturbance characteristics – Limits and methods of measurement*

CISPR 17, *Methods of Measurement of the suppression characteristics of passive Radio Interference Filters and Suppression Components*

British Standard Code of Practice CP1006: 1955
General Aspects of Radio Interference 60 pages

Electrical Research Association Report 75-31, March 1975
Code of Practice for the Avoidance of electrical interference in Electronic instrumentation and system. 84 pages including bibliography

British Standards Institution (BSI)

BSI is the national body responsible for preparing British Standards and other standards-related publications, information and services.

BSI is incorporated by Royal Charter. British Standards and other standardization products are published by BSI Standards Limited.

About us

We bring together business, industry, government, consumers, innovators and others to shape their combined experience and expertise into standards-based solutions.

The knowledge embodied in our standards has been carefully assembled in a dependable format and refined through our open consultation process. Organizations of all sizes and across all sectors choose standards to help them achieve their goals.

Information on standards

We can provide you with the knowledge that your organization needs to succeed. Find out more about British Standards by visiting our website at bsigroup.com/standards or contacting our Customer Services team or Knowledge Centre.

Buying standards

You can buy and download PDF versions of BSI publications, including British and adopted European and international standards, through our website at bsigroup.com/shop, where hard copies can also be purchased.

If you need international and foreign standards from other Standards Development Organizations, hard copies can be ordered from our Customer Services team.

Subscriptions

Our range of subscription services are designed to make using standards easier for you. For further information on our subscription products go to bsigroup.com/subscriptions.

With **British Standards Online (BSOL)** you'll have instant access to over 55,000 British and adopted European and international standards from your desktop. It's available 24/7 and is refreshed daily so you'll always be up to date.

You can keep in touch with standards developments and receive substantial discounts on the purchase price of standards, both in single copy and subscription format, by becoming a **BSI Subscribing Member**.

PLUS is an updating service exclusive to BSI Subscribing Members. You will automatically receive the latest hard copy of your standards when they're revised or replaced.

To find out more about becoming a BSI Subscribing Member and the benefits of membership, please visit bsigroup.com/shop.

With a **Multi-User Network Licence (MUNL)** you are able to host standards publications on your intranet. Licences can cover as few or as many users as you wish. With updates supplied as soon as they're available, you can be sure your documentation is current. For further information, email bsmusales@bsigroup.com.

BSI Group Headquarters

389 Chiswick High Road London W4 4AL UK

Revisions

Our British Standards and other publications are updated by amendment or revision.

We continually improve the quality of our products and services to benefit your business. If you find an inaccuracy or ambiguity within a British Standard or other BSI publication please inform the Knowledge Centre.

Copyright

All the data, software and documentation set out in all British Standards and other BSI publications are the property of and copyrighted by BSI, or some person or entity that owns copyright in the information used (such as the international standardization bodies) and has formally licensed such information to BSI for commercial publication and use. Except as permitted under the Copyright, Designs and Patents Act 1988 no extract may be reproduced, stored in a retrieval system or transmitted in any form or by any means – electronic, photocopying, recording or otherwise – without prior written permission from BSI. Details and advice can be obtained from the Copyright & Licensing Department.

Useful Contacts:

Customer Services

Tel: +44 845 086 9001

Email (orders): orders@bsigroup.com

Email (enquiries): cservices@bsigroup.com

Subscriptions

Tel: +44 845 086 9001

Email: subscriptions@bsigroup.com

Knowledge Centre

Tel: +44 20 8996 7004

Email: knowledgecentre@bsigroup.com

Copyright & Licensing

Tel: +44 20 8996 7070

Email: copyright@bsigroup.com



...making excellence a habit.™