

BS EN 60811-501:2012



BSI Standards Publication

Electric and optical fibre cables — Test methods for non-metallic materials

Part 501: Mechanical tests — Tests for determining the mechanical properties of insulating and sheathing compounds

bsi.

...making excellence a habit.™

National foreword

This British Standard is the UK implementation of EN 60811-501:2012. It is identical to IEC 60811-501:2012.

In the UK, the relationship between the supersessions of BS EN 60811 series can be summarized as follows.

BS EN 60811-100 together with	Supersedes -
-201, -202, -203, -501	BS EN 60811-1-1:1995
-301, -302, -411, -601, -602, -603, -604	BS EN 60811-5-1:2000
-401, -412	BS EN 60811-1-2:1995
-402, -502, -503, -606	BS EN 60811-1-3:1995
-403, -404, -507	BS EN 60811-2-1:1998
-405, -409	BS EN 60811-3-2:1995
-406, -511, -605, -607	BS EN 60811-4-1:2004
-407, -408, -410, -510, -512, -513	BS EN 60811-4-2:2004
-504, -505, -506	BS EN 60811-1-4:1995
-508, -509	BS EN 60811-3-1:1995

Superseded standards are withdrawn

The UK participation in its preparation was entrusted by Technical Committee GEL/20, Electric cables, to Subcommittee GEL/20/17, Electric Cables - Low voltage.

A list of organizations represented on this committee can be obtained on request to its secretary.

This publication does not purport to include all the necessary provisions of a contract. Users are responsible for its correct application.

© The British Standards Institution 2012

Published by BSI Standards Limited 2012

ISBN 978 0 580 65323 0

ICS 29.035.01; 29.060.20

Compliance with a British Standard cannot confer immunity from legal obligations.

This British Standard was published under the authority of the Standards Policy and Strategy Committee on 31 July 2012.

Amendments issued since publication

Amd. No.	Date	Text affected
<hr/>		

English version

**Electric and optical fibre cables -
Test methods for non-metallic materials -
Part 501: Mechanical tests -
Tests for determining the mechanical properties of insulating
and sheathing compounds
(IEC 60811-501:2012)**

Câbles électriques et à fibres optiques -
Méthodes d'essai pour les matériaux
non-métalliques -
Partie 501: Essais mécaniques -
Détermination des propriétés mécaniques
des mélanges pour les enveloppes
isolantes et les gaines
(CEI 60811-501:2012)

Kabel, isolierte Leitungen und
Glasfaserkabel - Prüfverfahren
für nichtmetallene Werkstoffe -
Teil 501: Mechanische Prüfungen -
Prüfungen zur Bestimmung
der mechanischen Eigenschaften
von Isolier- und Mantelwerkstoffen
(IEC 60811-501:2012)

This European Standard was approved by CENELEC on 2012-04-17. CENELEC members are bound to comply with the CEN/CENELEC Internal Regulations which stipulate the conditions for giving this European Standard the status of a national standard without any alteration.

Up-to-date lists and bibliographical references concerning such national standards may be obtained on application to the CEN-CENELEC Management Centre or to any CENELEC member.

This European Standard exists in three official versions (English, French, German). A version in any other language made by translation under the responsibility of a CENELEC member into its own language and notified to the CEN-CENELEC Management Centre has the same status as the official versions.

CENELEC members are the national electrotechnical committees of Austria, Belgium, Bulgaria, Croatia, Cyprus, the Czech Republic, Denmark, Estonia, Finland, France, Germany, Greece, Hungary, Iceland, Ireland, Italy, Latvia, Lithuania, Luxembourg, Malta, the Netherlands, Norway, Poland, Portugal, Romania, Slovakia, Slovenia, Spain, Sweden, Switzerland, Turkey and the United Kingdom.

CENELEC

European Committee for Electrotechnical Standardization
Comité Européen de Normalisation Electrotechnique
Europäisches Komitee für Elektrotechnische Normung

Management Centre: Avenue Marnix 17, B - 1000 Brussels

Foreword

The text of document 20/1297/FDIS, future edition 1 of IEC 60811-501, prepared by IEC/TC 20 "Electric cables" was submitted to the IEC-CENELEC parallel vote and approved by CENELEC as EN 60811-501:2012.

The following dates are fixed:

- latest date by which the document has to be implemented at national level by publication of an identical national standard or by endorsement (dop) 2013-01-17
- latest date by which the national standards conflicting with the document have to be withdrawn (dow) 2015-04-17

This document supersedes Clause 9 of EN 60811-1-1:1995 + A1:2001 (partially). Full details of the replacements are shown in Annex A of EN 60811-100:2012.

EN 60811-501:2012 includes the following significant technical change with respect to EN 60811-1-1:1995:

- the requirements for the (minimum) thickness of dumb-bell test pieces have changed.

See also the Foreword to EN 60811-100.

This standard is to be read in conjunction with EN 60811-100.

Attention is drawn to the possibility that some of the elements of this document may be the subject of patent rights. CENELEC [and/or CEN] shall not be held responsible for identifying any or all such patent rights.

This standard covers the Principle Elements of the Safety Objectives for Electrical Equipment Designed for Use within Certain Voltage Limits (LVD - 2006/95/EC).

Endorsement notice

The text of the International Standard IEC 60811-501:2012 was approved by CENELEC as a European Standard without any modification.

In the official version, for Bibliography, the following note has to be added for the standard indicated :

IEC 60811-1-1:1993 NOTE Harmonized as EN 60811-1-1:1995 (not modified).

Annex ZA
(normative)**Normative references to international publications
with their corresponding European publications**

The following documents, in whole or in part, are normatively referenced in this document and are indispensable for its application. For dated references, only the edition cited applies. For undated references, the latest edition of the referenced document (including any amendments) applies.

NOTE When an international publication has been modified by common modifications, indicated by (mod), the relevant EN/HD applies.

<u>Publication</u>	<u>Year</u>	<u>Title</u>	<u>EN/HD</u>	<u>Year</u>
IEC 60811-100	2012	Electric and optical fibre cables - Test methods for non-metallic materials - Part 100: General	EN 60811-100	2012
IEC 60811-201	-	Electric and optical fibre cables - Test methods for non-metallic materials - Part 201: General tests - Measurement of insulation thickness	EN 60811-201	-
IEC 60811-202	-	Electric and optical fibre cables - Test methods for non-metallic materials - Part 202: General tests - Measurement of thickness of non-metallic sheath	EN 60811-202	-
IEC 60811-203	-	Electric and optical fibre cables - Test methods for non-metallic materials - Part 203: General tests - Measurement of overall dimensions	EN 60811-203	-
IEC 60811-401	-	Electric and optical fibre cables - Test methods for non-metallic materials - Part 401: Miscellaneous tests - Thermal ageing methods - Ageing in an air oven	EN 60811-401	-
IEC 60811-404	-	Electric and optical fibre cables - Test methods for non-metallic materials - Part 404: Miscellaneous tests - Mineral oil immersion tests for sheaths	EN 60811-404	-
IEC 60811-606	-	Electric and optical fibre cables - Test methods for non-metallic materials - Part 606: Physical tests - Methods for determining the density	EN 60811-606	-

CONTENTS

INTRODUCTION.....	5
1 Scope.....	6
2 Normative references	6
3 Terms and definitions	6
4 Test method	7
4.1 General.....	7
4.2 Insulation	7
4.2.1 General	7
4.2.2 Sampling	7
4.2.3 Preparation and conditioning of test pieces	7
4.2.4 Determination of cross-sectional area.....	9
4.2.5 Ageing treatment	11
4.2.6 Tensile testing procedure	11
4.2.7 Expression of results	11
4.3 Sheath	12
4.3.1 General	12
4.3.2 Sampling	12
4.3.3 Preparation and conditioning of test pieces	12
4.3.4 Determination of cross-sectional area.....	12
4.3.5 Ageing treatment	13
4.3.6 Tensile testing procedure	13
4.3.7 Expression of results	13
5 Test report.....	13
Annex A (informative) Principle of operation of a typical machine for preparing test pieces.....	16
Bibliography.....	17
Figure 1 – Dumb-bell test piece	14
Figure 2 – Small dumb-bell test piece	14
Figure 3 – Punch end showing groove	14
Figure 4 – Test pieces cut by grooved punch	15
Figure A.1 – Machine for preparing test pieces	16

INTRODUCTION

The IEC 60811 series specifies the test methods to be used for testing non-metallic materials of all types of cables. These test methods are intended to be referenced in standards for cable construction and for cable materials.

NOTE 1 Non-metallic materials are typically used for insulating, sheathing, bedding, filling or taping within cables.

NOTE 2 These test methods are accepted as basic and fundamental and have been developed and used over many years principally for the materials in all energy cables. They have also been widely accepted and used for other cables, in particular optical fibre cables, communication and control cables and cables for ships and offshore applications.

ELECTRIC AND OPTICAL FIBRE CABLES – TEST METHODS FOR NON-METALLIC MATERIALS –

Part 501: Mechanical tests – Tests for determining the mechanical properties of insulating and sheathing compounds

1 Scope

This Part 501 of IEC 60811 gives the procedure for determining the mechanical properties, which typically applies to cross-linked and thermoplastic compounds used for insulating and sheathing materials.

2 Normative references

The following documents, in whole or in part, are normatively referenced in this document and are indispensable for its application. For dated references, only the edition cited applies. For undated references, the latest edition of the referenced document (including any amendments) applies.

IEC 60811-100:2012, *Electric and optical fibre cables – Test methods for non-metallic materials – Part 100: General*

IEC 60811-201, *Electric and optical fibre cables – Test methods for non-metallic materials – Part 201: General tests – Measurement of insulation thickness*

IEC 60811-202, *Electric and optical fibre cables – Test methods for non-metallic materials – Part 202: General tests – Measurement of thickness of non-metallic sheaths*

IEC 60811-203, *Electric and optical fibre cables – Test methods for non-metallic materials – Part 203: General tests – Measurement of overall dimensions*

IEC 60811-401, *Electric and optical fibre cables – Test methods for non-metallic materials – Part 401: Miscellaneous tests – Thermal ageing methods – Ageing in an air oven*

IEC 60811-404, *Electric and optical fibre cables – Test methods for non-metallic materials – Part 404: Miscellaneous tests – Mineral oil immersion tests for sheaths made with cross-linked compounds*

IEC 60811-606, *Electric and optical fibre cables – Test methods for non-metallic materials – Part 606: Physical tests – Methods for determining the density*

3 Terms and definitions

For the purposes of this document, the terms and definitions given in IEC 60811-100, together with the following, apply.

3.1

maximum tensile force

highest value reached by the load during the test

3.2

tensile stress

tensile force per unit of the cross-sectional area of the unstretched test piece

3.3

tensile strength

maximum tensile stress recorded in extending the test piece to breaking point

3.4

elongation at break

increase of the length between the reference marks of the test piece, expressed as the percentage of the length between the reference marks of the unstretched test piece at breaking point

4 Test method

4.1 General

This part of IEC 60811 shall be used in conjunction with IEC 60811-100.

Unless otherwise specified, before any test, all test pieces, aged and unaged, shall be kept for at least 3 h at a temperature of (23 ± 5) °C.

4.2 Insulation

4.2.1 General

These tests are to determine the tensile strength and elongation at break of the insulating material (exclusive of any semi-conducting layers) of the cable in the condition as manufactured (i.e. without any ageing treatment) and, when required, after one or more accelerated ageing treatment(s), which are prescribed in the relevant cable standard.

When the ageing treatment is to be carried out on prepared test pieces (in accordance with IEC 60811-401), the test pieces for the ageing treatment shall be from positions adjacent to the test pieces used for the test without ageing and the tensile tests on the aged and unaged test pieces shall be made in immediate succession.

NOTE Where further increased test reliability is necessary, it is recommended that the tests on aged and unaged test pieces are performed by the same person using the same testing method and the same apparatus, in the same laboratory.

4.2.2 Sampling

One sample of each core to be tested (or of the insulation from each core to be tested) shall be taken of sufficient size to provide a minimum of five test pieces each for the tensile tests without ageing and the tensile tests after each of the required ageing treatments, bearing in mind that a 100 mm length is needed for the preparation of each test piece.

The cores of unsheathed flat cables shall not be separated.

Any sample that shows signs of mechanical damage shall not be used for the test.

4.2.3 Preparation and conditioning of test pieces

a) Conditioning of test pieces shall be carried out as follows:

1) Elevated temperature conditioning

NOTE 1 Elevated temperature conditioning is not an ageing treatment. It is used as a means of ensuring stable and consistent test pieces when required. It is used a) when called for in the relevant cable standard, or b) if there is a doubt or disagreement about a result and the test needs to be repeated. In

either case, the conditioning applies only to the test piece as taken from the cable before any subsequent treatment (ageing, compatibility test, oil immersion etc).

Where conditioning at elevated temperature is used, such conditioning shall be carried out as follows:

- for dumb-bells,
 - (A) after the removal of the insulation from the cable and removal of semi-conducting layers (if any) but before the cutting of strips;
 - (B) after grinding (or cutting) to obtain parallel surfaces.

Where grinding (or cutting) is not needed, the conditioning shall be performed at the point in the test protocol according to (A);

- for tubular test pieces, such conditioning shall be carried out after removal of the conductor, and any separator, but before applying the reference marks, if any, for measurement of the extension.

Where the relevant cable standard calls for conditioning at elevated temperature, it shall be for the time and temperature given in that standard. Where, in case of doubt, the test has to be repeated, the conditioning shall be 24 h at $(70 \pm 2) ^\circ\text{C}$, or a lower temperature corresponding to the maximum operating temperature of the conductor.

2) Room temperature conditioning

Before determination of the cross-sectional area, all test pieces shall be protected from direct sunlight and maintained for at least 3 h at a temperature of $(23 \pm 5) ^\circ\text{C}$, except for thermoplastic insulating materials which shall be kept at $(23 \pm 2) ^\circ\text{C}$.

b) Dumb-bell test pieces

Dumb-bell test pieces shall be used whenever possible. They shall be prepared from samples of insulation removed from the conductor, cut open in the direction of the axis of the core.

Semi-conducting layers, if any, inside and/or outside the insulation, shall be removed mechanically, i.e. without using a solvent.

Each sample of insulation shall be cut into strips of an appropriate length. The strips shall be marked to identify the sample from which they are cut and their positions relative to each other in the original sample.

The strips of insulation shall be ground or cut, so as to obtain two parallel smooth surfaces between the reference marks mentioned below, care being taken to avoid undue heating. An example of a cutting machine is given in Annex A. For polyethylene (PE) and polypropylene (PP) insulation, cutting only, not grinding, shall be employed. After cutting or grinding, including any removal of burrs, the thickness of the strips shall not be less than 0,8 mm and not more than 2,0 mm. If it is not possible to prepare dumb-bell test pieces that comply with the minimum thickness of 0,8 mm, then tubular test pieces shall be used. If tubular test pieces cannot be prepared, then dumb-bells thinner than 0,8 mm may be used, but the rate of separation shall be 25 mm/min.

NOTE 2 The test report should also include the fact that non-compliant dumb-bells were used and that the result is indicative.

NOTE 3 For certain tests, a minimum thickness may be required, for instance for the ozone resistance test (IEC 60811-403) and the mineral oil immersion test (IEC 60811-404).

A dumb-bell test piece, in accordance with Figure 1, shall then be punched from each prepared strip of insulation, or if possible, two dumb-bell test pieces shall be punched side by side.

In order to improve the reliability of the results, the following is recommended:

- the punch shall be very sharp to minimize imperfections in the test piece;
- a cardboard or other suitable support shall be placed between the strip and the base plate. This support shall be marked during punching, but not completely cut through by the punch;
- burrs on the sides of the test piece shall be avoided.

For materials where punching results in burrs, the following method may be used:

- 1) each end of the punch shall have a groove approximately 2,5 mm wide and 2,5 mm high (see Figure 3);
- 2) the cut dumb-bell test pieces shall remain attached at both ends with the strip previously prepared according to the requirements of 4.2.3 b) (see Figure 4);
- 3) with the machine given in Annex A, an additional 0,10 mm to 0,15 mm thickness can be cut away to remove possible burrs resulting from the dumb-bell punch. When this operation is completed, the dumb-bell test pieces shall be cut through at their ends in order to remove them from the strip.

When the diameter of the core is too small to allow the dumb-bell to be cut in accordance with Figure 1, then a smaller dumb bell test piece in accordance with Figure 2, shall be punched from each prepared strip.

The central 20 mm for the larger dumb-bells or 10 mm for the smaller dumb-bells shall be marked on each test piece, immediately before the tensile test.

NOTE 4 Where a contact extensometer is used, the pre set grips at the required spacing are deemed to constitute a mark.

Dumb-bell test pieces with incomplete ends are permitted, provided that the breaking point occurs between the reference marks.

c) Tubular test pieces

Tubular test pieces shall be used only when the dimensions of the core are such that it is not possible to prepare dumb-bell test pieces.

The samples of core shall be cut into pieces approximately 100 mm long and the conductor and any outer coverings removed, care being taken not to damage the insulation. The tubes shall be marked to identify the sample from which they were prepared and their relative positions in the sample.

Careful removal of the conductor can be facilitated by the use of one or more of the following operations:

- 1) by elongation of the rigid conductors;
- 2) by careful rolling of the core under low mechanical force;
- 3) in the case of stranded or flexible conductors, by first removing one or more of the central strands or wires.

After removal of the conductor, the separators, if any, are removed. In case of difficulty, one of the following operations may be used:

- immersion in water, in the case of paper separators;
- immersion in ethyl alcohol, in the case of polyethylene terephthalate separators;
- rolling of the insulation on a smooth surface.

The central 20 mm shall be marked immediately before the tensile test.

NOTE 5 Where a contact extensometer is used, the pre set grips at the required spacing are deemed to constitute a mark.

The presence of pieces of separator remaining inside the test piece can be observed during the tensile tests by formation of irregularities in the test piece during elongation.

In such cases, the result shall be rejected.

4.2.4 Determination of cross-sectional area

a) Dumb-bell test piece

The cross-sectional area of each test piece is the product of the common width and the measured individual minimum thickness which shall be determined as follows.

For the width:

- the common width is the minimum width of three, randomly selected test pieces;
- if there is doubt about the uniformity of the width, this shall be measured at three positions on the top and the bottom side of the three test pieces. The mean of the top and bottom side measurements shall be calculated for each position. The common width shall be the minimum of the nine mean values determined on the three test pieces;
- in the case of further doubt, the width is measured on each individual test piece.

For the thickness:

- the thickness of each test piece is the minimum of three thickness measurements carried out in the area to be stretched.

The measurements shall be carried out by an optical instrument or by a dial gauge giving a contact pressure not exceeding 0,07 N/mm².

The instrument shall be capable of measuring the thickness with an error of not more than 0,01 mm and the width with an error of not more than 0,04 mm.

In case of doubt, where technically possible, an optical instrument shall be used. Alternatively, a dial gauge with a maximum contact pressure of 0,02 N/mm² may be used.

NOTE An appropriate curved foot of the dial gauge should be used if the central part of the dumb-bell is still curved.

b) Tubular test piece

In the middle of the sample being used to prepare the test pieces, a piece shall be taken to determine the cross-sectional area, A , in square millimetres, of the test piece, using one of the following methods. In case of doubt, the second method b2) shall be used.

b1) From the dimensions, using the formula:

$$A = \pi (D - \delta) \delta$$

where

δ is the mean value of the thickness of the insulation, in millimetres, determined as specified in IEC 60811-201 and rounded off to two decimal places;

D is the mean value of the outer diameter of the test piece, in millimetres, determined as specified in test method of IEC 60811-203 and rounded off to two decimal places.

b2) From the density, the mass and the length, using the formula:

$$A = \frac{1\,000\ m}{d \times l}$$

where

m is the mass of the test piece, in grams, to three decimal places;

d is the density, measured in accordance with IEC 60811-606 on an additional sample of the same insulation (without ageing) in grams per cubic centimetre, to three decimal places;

l is the length, in millimetres, to one decimal place.

b3) From the volume and the length, the volume being determined by means of immersion in for example ethyl alcohol using the formula:

$$A = \frac{V}{l}$$

where

V is the volume, in cubic millimetres, to two decimal places;

l is the length, in millimetres, to one decimal place.

Care shall be taken to avoid air bubbles in or on the surface of the test piece during immersion.

c) Sequence of determination of cross-sectional area and ageing

For test pieces which are to be aged, the cross-sectional area shall be determined before ageing treatment, unless the insulation is to be aged in the presence of the conductor.

4.2.5 Ageing treatment

Each required ageing treatment shall be carried out on a minimum of five test pieces (see 4.2.2) in accordance with IEC 60811-401, under the conditions specified in the relevant cable standard.

4.2.6 Tensile testing procedure

The test procedure shall be as follows:

a) Test temperature

The test shall be carried out at a temperature of (23 ± 5) °C. In case of doubt for thermoplastic insulation, the test shall be carried out at (23 ± 2) °C.

b) Distance between the grips and rate of separation

The grips of the tensile testing machine may be either of a self-tightening type or not.

The total length between the grips shall be about

- 34 mm for dumb-bells as illustrated in Figure 2,
- 50 mm for dumb-bells as illustrated in Figure 1,
- 50 mm for tubes, if tested with self-tightening grips,
- 85 mm for tubes, if tested with non-self-tightening grips.

The rate of separation, except for PE and PP insulations, shall be (250 ± 50) mm/min and, in case of doubt, (25 ± 5) mm/min.

For PE and PP, or insulations containing these materials, the rate of separation shall be (25 ± 5) mm/min, but for routine tests, separation rates up to (250 ± 50) mm/min are permitted.

c) Measurements

The maximum tensile force during the test shall be measured and recorded and the distance between the two reference marks at breaking point shall be measured on the same test piece.

An unsatisfactory result due to any test piece breaking due to damage in the grips shall be ignored. In this event, at least four valid results shall be obtained in order to calculate the tensile strength and elongation at break; otherwise the test shall be repeated.

4.2.7 Expression of results

Calculate the tensile strength and the elongation at break according to the definitions given in 3.3 and 3.4, respectively.

The median value of the results shall be determined.

4.3 Sheath

4.3.1 General

These tests are to determine the tensile strength and elongation at break of the sheathing material of the cable in the condition as manufactured (i.e. without any ageing treatment) and, when required, after one or more accelerated ageing treatment(s), which are prescribed in the relevant cable standard.

When the ageing treatment has to be carried out on prepared test pieces (in accordance with IEC 60811-401 or with IEC 60811-404), the test pieces for the ageing treatment shall be from positions adjacent to the test pieces used for the test without ageing, and the tensile tests on the aged and unaged test pieces shall be in immediate succession.

NOTE Where further increased reliability is necessary, it is recommended that the tests on aged and unaged test pieces are performed by the same person using the same testing method and the same apparatus, in the same laboratory.

4.3.2 Sampling

One sample of the cable or cord to be tested, or of the sheath removed from the cable, shall be taken of sufficient size to provide a minimum of five test pieces for the tensile tests without ageing and the required number of test pieces for each of the tensile tests after ageing specified for the sheathing material in the standard for the type of cable in question, bearing in mind that about 100 mm is needed for the preparation of each test piece.

Any sample that shows signs of mechanical damage shall not be used for the tests.

4.3.3 Preparation and conditioning of test pieces

Test pieces shall be prepared from the samples of sheath in the same way as specified for insulation in 4.2.3.

In the preparation of dumb-bell test pieces, a strip shall be cut from the sheath in the direction of the axis of the cables. All other cable components shall be removed from the strip. If the strip has ridges or imprints, these shall be removed by cutting or grinding. For PE and PP and similar sheaths, only cutting is allowed.

NOTE For PE sheaths, the thickness of the dumb-bell does not need to be reduced to 2,0 mm, when the full sheath thickness is greater, provided that the test pieces are smooth on both surfaces.

In the preparation of tubular test pieces, all the components of the cable inside the sheath, including cores, fillers and inner covering, shall be removed.

For conditioning of the test pieces, see 4.2.3 a).

4.3.4 Determination of cross-sectional area

The cross-sectional area of each test piece shall be determined by the same method as for the insulation specified in 4.2.4, with the following modifications for tubular test pieces:

- the thickness and diameter of the sheath, measured in accordance with IEC 60811-202 for thickness, and to IEC 60811-203 for diameter, shall be used in the method b1) of 4.2.4;
- the density shall be measured on an additional piece of the same sheath in the method b2) of 4.2.4.

NOTE The b2) method should not be used for multi-layer materials. Methods b1) and b3) are valid for multi-layer materials.

4.3.5 Ageing treatment

Each required ageing treatment shall be carried out on a minimum of five test pieces (see 4.3.2) in accordance with IEC 60811-401, under the conditions specified in the standard for the particular type of cable.

4.3.6 Tensile testing procedure

In accordance with 4.2.6.

4.3.7 Expression of results

In accordance with 4.2.7.

5 Test report

The test report shall be in accordance with that given in IEC 60811-100.

Dimension in millimeters

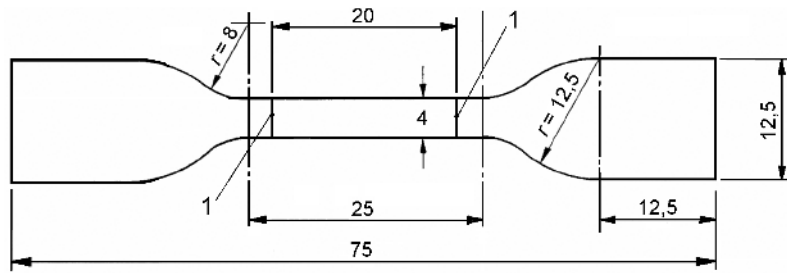

IEC 260/12

Key

1 reference marks

Figure 1 – Dumb-bell test piece

Dimensions in millimeters

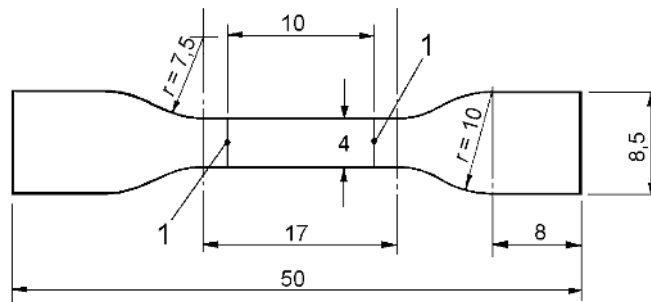

IEC 261/12

Key

1 reference marks

Figure 2 – Small dumb-bell test piece

Dimensions in millimeters

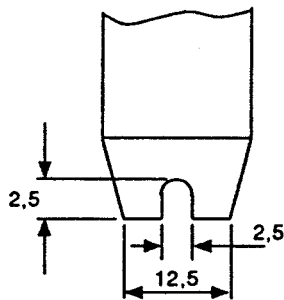

IEC 265/12

Figure 3 – Punch end showing groove

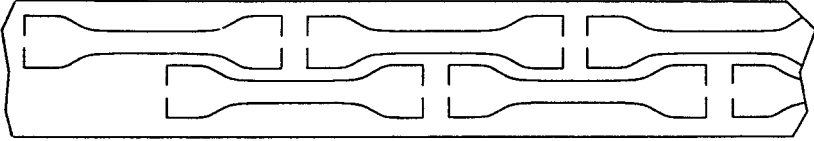

IEC 266/12

Figure 4 – Test pieces cut by grooved punch

Annex A (informative)

Principle of operation of a typical machine for preparing test pieces

Two rolls, one made of steel and partly grooved (1), and the other, in rubber-tyred steel (2), drive the strip (3) against a highly sharpened fixed, or moving blade (4) (surgical scalpel quality).

The strip is longitudinally cut into two parts: part (5) from which the test piece is cut, and part (6) which is rejected.

NOTE The thickness of part (6) can be limited to 0,1 mm if necessary. (For this purpose, consideration should be given to the behaviour of the material prepared and the preservation of the blade sharpness.)

When the strip (3) has marks of tearing or scratching, which may induce a premature break, it is recommended that part (6) be cut and rejected from both sides.

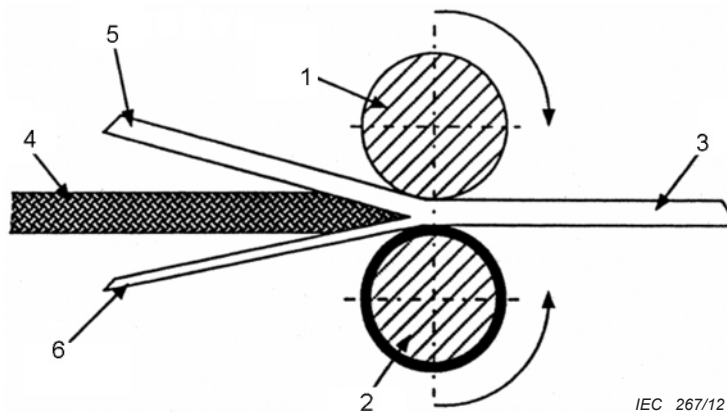

Key

- | | | | |
|---|----------------------------|---|-----------------------------------|
| 1 | steel roll, partly grooved | 4 | blade, fixed or moving |
| 2 | steel roll, rubber-tyred | 5 | part of strip used for test piece |
| 3 | strip | 6 | rejected part of strip |

Figure A.1 – Machine for preparing test pieces

Bibliography

IEC 60811-1-1:1993, *Common test methods for insulating and sheathing materials of electric cables – Part 1: Methods for general application – Section 1: Measurement of thickness and overall dimensions – Tests for determining the mechanical properties*
(withdrawn)

British Standards Institution (BSI)

BSI is the national body responsible for preparing British Standards and other standards-related publications, information and services.

BSI is incorporated by Royal Charter. British Standards and other standardization products are published by BSI Standards Limited.

About us

We bring together business, industry, government, consumers, innovators and others to shape their combined experience and expertise into standards-based solutions.

The knowledge embodied in our standards has been carefully assembled in a dependable format and refined through our open consultation process. Organizations of all sizes and across all sectors choose standards to help them achieve their goals.

Information on standards

We can provide you with the knowledge that your organization needs to succeed. Find out more about British Standards by visiting our website at bsigroup.com/standards or contacting our Customer Services team or Knowledge Centre.

Buying standards

You can buy and download PDF versions of BSI publications, including British and adopted European and international standards, through our website at bsigroup.com/shop, where hard copies can also be purchased.

If you need international and foreign standards from other Standards Development Organizations, hard copies can be ordered from our Customer Services team.

Subscriptions

Our range of subscription services are designed to make using standards easier for you. For further information on our subscription products go to bsigroup.com/subscriptions.

With **British Standards Online (BSOL)** you'll have instant access to over 55,000 British and adopted European and international standards from your desktop. It's available 24/7 and is refreshed daily so you'll always be up to date.

You can keep in touch with standards developments and receive substantial discounts on the purchase price of standards, both in single copy and subscription format, by becoming a **BSI Subscribing Member**.

PLUS is an updating service exclusive to BSI Subscribing Members. You will automatically receive the latest hard copy of your standards when they're revised or replaced.

To find out more about becoming a BSI Subscribing Member and the benefits of membership, please visit bsigroup.com/shop.

With a **Multi-User Network Licence (MUNL)** you are able to host standards publications on your intranet. Licences can cover as few or as many users as you wish. With updates supplied as soon as they're available, you can be sure your documentation is current. For further information, email bsmusales@bsigroup.com.

BSI Group Headquarters

389 Chiswick High Road London W4 4AL UK

Revisions

Our British Standards and other publications are updated by amendment or revision.

We continually improve the quality of our products and services to benefit your business. If you find an inaccuracy or ambiguity within a British Standard or other BSI publication please inform the Knowledge Centre.

Copyright

All the data, software and documentation set out in all British Standards and other BSI publications are the property of and copyrighted by BSI, or some person or entity that owns copyright in the information used (such as the international standardization bodies) and has formally licensed such information to BSI for commercial publication and use. Except as permitted under the Copyright, Designs and Patents Act 1988 no extract may be reproduced, stored in a retrieval system or transmitted in any form or by any means – electronic, photocopying, recording or otherwise – without prior written permission from BSI. Details and advice can be obtained from the Copyright & Licensing Department.

Useful Contacts:

Customer Services

Tel: +44 845 086 9001

Email (orders): orders@bsigroup.com

Email (enquiries): cservices@bsigroup.com

Subscriptions

Tel: +44 845 086 9001

Email: subscriptions@bsigroup.com

Knowledge Centre

Tel: +44 20 8996 7004

Email: knowledgecentre@bsigroup.com

Copyright & Licensing

Tel: +44 20 8996 7070

Email: copyright@bsigroup.com



...making excellence a habit.™