



BSI Standards Publication

Optical fibre cables

Part 1-23: Generic specification —
Basic optical cable test procedures —
Cable element test methods

NO COPYING WITHOUT BSI PERMISSION EXCEPT AS PERMITTED BY COPYRIGHT LAW

National foreword

This British Standard is the UK implementation of EN 60794-1-23:2012. It is identical to IEC 60794-1-23:2012. Together with BS EN 60794-1-2, BS EN 60794-1-20, BS EN 60794-1-21, BS EN 60794-1-22:2012 and BS EN 60794-1-24, it supersedes BS EN 60794-1-2:2003, which will be withdrawn when all parts listed above have been published.

The UK participation in its preparation was entrusted by Technical Committee GEL/86, Fibre optics, to Subcommittee GEL/86/1, Optical fibres and cables.

A list of organizations represented on this committee can be obtained on request to its secretary.

This publication does not purport to include all the necessary provisions of a contract. Users are responsible for its correct application.

© The British Standards Institution 2013.

Published by BSI Standards Limited 2013

ISBN 978 0 580 74248 4

ICS 33.180.10

Compliance with a British Standard cannot confer immunity from legal obligations.

This British Standard was published under the authority of the Standards Policy and Strategy Committee on 31 January 2013.

Amendments issued since publication

Date	Text affected
------	---------------

English version

**Optical fibre cables -
Part 1-23: Generic specification -
Basic optical cable test procedures -
Cable element test methods
(IEC 60794-1-23:2012)**

Câbles à fibres optiques -
Partie 1-23: Spécification générique -
Procédures fondamentales d'essai des
câbles optiques -
Méthodes d'essais d'éléments de câbles
(CEI 60794-1-23:2012)

Lichtwellenleiterkabel -
Teil 1-23: Fachgrundspezifikation -
Grundlegende Prüfverfahren für
Lichtwellenleiterkabel -
Prüfverfahren für Kabelemente
(IEC 60794-1-23:2012)

This European Standard was approved by CENELEC on 2012-09-28. CENELEC members are bound to comply with the CEN/CENELEC Internal Regulations which stipulate the conditions for giving this European Standard the status of a national standard without any alteration.

Up-to-date lists and bibliographical references concerning such national standards may be obtained on application to the CEN-CENELEC Management Centre or to any CENELEC member.

This European Standard exists in three official versions (English, French, German). A version in any other language made by translation under the responsibility of a CENELEC member into its own language and notified to the CEN-CENELEC Management Centre has the same status as the official versions.

CENELEC members are the national electrotechnical committees of Austria, Belgium, Bulgaria, Croatia, Cyprus, the Czech Republic, Denmark, Estonia, Finland, Former Yugoslav Republic of Macedonia, France, Germany, Greece, Hungary, Iceland, Ireland, Italy, Latvia, Lithuania, Luxembourg, Malta, the Netherlands, Norway, Poland, Portugal, Romania, Slovakia, Slovenia, Spain, Sweden, Switzerland, Turkey and the United Kingdom.

CENELEC

European Committee for Electrotechnical Standardization
Comité Européen de Normalisation Electrotechnique
Europäisches Komitee für Elektrotechnische Normung

Management Centre: Avenue Marnix 17, B - 1000 Brussels

Foreword

The text of document 86A/1451/FDIS, future edition 1 of IEC 60794-1-23, prepared by SC 86A, "Fibres and cables", of IEC TC 86, "Fibre optics" was submitted to the IEC-CENELEC parallel vote and approved by CENELEC as EN 60794-1-23:2012.

The following dates are fixed:

- latest date by which the document has to be implemented at national level by publication of an identical national standard or by endorsement (dop) 2013-06-28
- latest date by which the national standards conflicting with the document have to be withdrawn (dow) 2015-09-28

This document partially supersedes EN 60794-1-2:2003.

Attention is drawn to the possibility that some of the elements of this document may be the subject of patent rights. CENELEC [and/or CEN] shall not be held responsible for identifying any or all such patent rights.

Endorsement notice

The text of the International Standard IEC 60794-1-23:2012 was approved by CENELEC as a European Standard without any modification.

Annex ZA (normative)

Normative references to international publications with their corresponding European publications

The following documents, in whole or in part, are normatively referenced in this document and are indispensable for its application. For dated references, only the edition cited applies. For undated references, the latest edition of the referenced document (including any amendments) applies.

NOTE When an international publication has been modified by common modifications, indicated by (mod), the relevant EN/HD applies.

<u>Publication</u>	<u>Year</u>	<u>Title</u>	<u>EN/HD</u>	<u>Year</u>
IEC 60793-1-40	-	Optical fibres - Part 1-40: Measurement methods and test procedures - Attenuation	EN 60793-1-40	-
IEC 60794-3	2001	Optical fibre cables - Part 3: Sectional specification - Outdoor cables	EN 60794-3	2002

CONTENTS

1	Scope and object.....	6
2	Normative references	6
3	Method G1: Bend test for cable elements	6
3.1	Object	6
3.2	Sample.....	6
3.3	Apparatus.....	6
3.4	Procedure	7
3.5	Requirements	7
3.6	Details to be specified	7
4	Method G2: Ribbon dimensions and geometry – Visual method	7
4.1	Object	7
4.2	Sample.....	7
4.3	Apparatus.....	7
4.4	Procedure	7
4.4.1	General	7
4.4.2	Method 1	7
4.4.3	Method 2	8
4.5	Requirements	8
4.6	Details to be specified	8
4.7	Definitions of ribbon dimensions and geometry.....	8
4.7.1	General	8
4.7.2	Width and height	8
4.7.3	Basis line.....	8
4.7.4	Fibre alignment.....	8
5	Method G3: Ribbon dimensions – Aperture gauge	9
5.1	Object	9
5.2	Sample.....	9
5.3	Apparatus.....	9
5.4	Procedure	9
5.5	Requirement.....	10
5.6	Details to be specified	10
6	Method G4: Ribbon dimensions – Dial gauge (Test deleted).....	10
7	Method G5: Ribbon tear (separability)	10
7.1	Object	10
7.2	Sample.....	10
7.3	Apparatus.....	11
7.4	Procedure	11
7.5	Requirements	11
7.6	Details to be specified	11
8	Method G6: Ribbon torsion	12
8.1	Object	12
8.2	Sample.....	12
8.3	Apparatus.....	12
8.4	Procedure	12
8.5	Requirements	12

8.6	Details to be specified	12
9	Method G7: Tube kinking.....	13
9.1	Object	13
9.2	Sample.....	13
9.3	Apparatus.....	13
9.4	Procedure	14
9.5	Requirements	14
9.6	Details to be specified	15
10	Method G8: Ribbon residual twist test	15
10.1	Object	15
10.2	Sample.....	15
10.3	Apparatus.....	15
10.4	Procedure	16
10.5	Requirements	16
10.6	Details to be specified	16
Figure 1 – Cross-sectional drawing illustrating fibre ribbon geometry		9
Figure 2 – Aperture gauge		10
Figure 3 – Sample preparation.....		11
Figure 4 – Separability procedure		12
Figure 5 – Torsion test.....		13
Figure 6 – Tube kinking test.....		15
Table 1 – Examples of test apparatus dimensions:.....		14

OPTICAL FIBRE CABLES –

Part 1-23: Generic specification – Basic optical cable test procedures – Cable element test methods

1 Scope and object

This part of IEC 60794 applies to optical fibre cables for use with telecommunication equipment and devices employing similar techniques, and to cables having a combination of both optical fibres and electrical conductors.

The object of this part of IEC 60794 is to define test procedures to be used in establishing uniform requirements for the geometrical, material, mechanical, environmental properties of optical fibre cable elements.

Throughout the document the wording “optical cable” may also include optical fibre units, microduct fibre units, etc.

General requirements and definitions are given in IEC 60794-1-20 and a complete reference guide to test method of all types in the IEC 60794-1-2.

2 Normative references

The following documents, in whole or in part, are normatively referenced in this document and are indispensable for its application. For dated references, only the edition cited applies. For undated references, the latest edition of the referenced document (including any amendments) applies.

IEC 60793-1-40, *Optical fibres – Part 1-40: Measurement methods and test procedures – Attenuation*

IEC 60794-3:2001, *Optical fibre cables – Part 3: Sectional specification – Outdoor cables*

3 Method G1: Bend test for cable elements

3.1 Object

The purpose of this test is to characterize cable elements for splicing purposes by determining the attenuation increase of an optical (fibre, ribbon, core tube, breakout unit, etc.) element when bent within a splice closure or similar device.

3.2 Sample

The length of the sample of optical element shall be sufficient to carry out the testing specified.

3.3 Apparatus

The apparatus consists of:

- a) a mandrel having a smooth surface with diameter as stated in the detail specification;

b) an attenuation measuring apparatus (see IEC 60793-1-40).

3.4 Procedure

The element to be tested shall be loosely wound on the mandrel; the number of turns shall be stated in the detail specification.

In order to measure the attenuation increase caused by bending, allowance should be made for the intrinsic attenuation of the fibre.

3.5 Requirements

Any increase in attenuation shall comply with the limits shown in the detail specification.

3.6 Details to be specified

The detail specification shall include the following:

- a) optical test wavelength;
- b) diameter of the mandrel;
- c) number of turns;
- d) apparatus and attenuation measuring technique;
- e) temperature.

4 Method G2: Ribbon dimensions and geometry – Visual method

4.1 Object

The purpose of this test is to determine the geometry of an optical fibre ribbon as defined by the parameters of width, height and fibre alignment, for the purpose of type testing to assume proper manufacturing process control. This test is not necessarily suitable for final product inspection and, unless otherwise specified, shall not be used for that purpose.

4.2 Sample

The number of samples to be tested shall be specified in the detail specification. The selected samples shall be statistically independent and representative of the ribbon population tested.

4.3 Apparatus

The apparatus consists of a microscope or profile projector with appropriate magnification.

4.4 Procedure

4.4.1 General

Either of the two following procedures may be used.

For the specified number of samples, all dimensions shall be measured as average as well as maximum and minimum values.

4.4.2 Method 1

The sample is prepared by cutting it perpendicular to the axis of the ribbon and placing it in a curable resin or in a tool which holds the ribbon. If necessary, the sample shall be ground and polished to prepare a smooth perpendicular end face. The prepared sample is secured with its end face perpendicular to the optical path and measured by means of a microscope or profile projector.

NOTE Care should be taken that the preparation of the sample does not change the structure of the fibre ribbon and represents an undisturbed image of the fibre cladding and ribbon cross-section.

4.4.3 Method 2

Place the ribbon in a ribbon fibre holder and remove 20 mm to 25 mm of the fibre coating and matrix material with the ribbon hot sheath stripping tool and wipe the stripped portion of the fibres clean with an alcohol-moistened pad. Adjust the position of the ribbon in the ribbon fibre holder and cleave the fibres at a distance of 250 μm to 500 μm from the stripped edge of the ribbon. Cut and polish the other end of the ribbon, and illuminate it with a collimated light source. Align and measure the cleaved end of the ribbon under microscope.

NOTE Care should be taken that the preparation of the sample does not change the structure of the fibre ribbon and represents an undisturbed image of the fibre cladding and ribbon cross-section.

4.5 Requirements

Unless otherwise specified in the detail specification, the width, height and fibre alignment shall be in accordance with IEC 60794-3:2001, Table 1.

4.6 Details to be specified

The detail specification shall include the following:

- a) permissible maximum and minimum values;
- b) average values;
- c) number of samples tested.

4.7 Definitions of ribbon dimensions and geometry

4.7.1 General

The following definitions apply to a fibre ribbon cross-section as shown in Figure 1. The figure illustrates an example for a 4-fibre ribbon, where a is the diameter of a coloured fibre.

NOTE In consideration of the precision of fiber geometric attributes and the relatively larger precision of ribbon geometry requirements, it is acceptable for glass core/glass cladding fibres to use the edge of the cladding for the measurements of 4.7.3 and 4.7.4 in lieu of the fibre centres. In this case, the measurements shall be made on the same side of all fibres (e.g. top or bottom, left or right side).

4.7.2 Width and height

The width w and height h of the ribbon are the dimensions of the minimum rectangular area enclosing the ribbon cross-section.

4.7.3 Basis line

The basis line is given in the cross-section of an optical fibre ribbon as the straight line crossing the fibre centres of the first fibre (fibre 1) and the last fibre (fibre n) of the fibre ribbon.

4.7.4 Fibre alignment

4.7.4.1 Horizontal fibre separation

The horizontal separation of fibres is the distance of the orthogonal projection of two fibre centres on the basis line in the fibre ribbon cross-section.

Two horizontal separation parameters can be distinguished:

- a) centre-centre distance d between adjacent fibres;
- b) centre-centre distance b between the extreme fibres;

4.7.4.2 Planarity

The planarity p of the fibre ribbon structure is the sum of the maximum positive and absolute values of the maximum negative vertical separation of the fibres.

The vertical separation of the fibres is the orthogonal distance from the fibre centre to the basis line. The vertical separation is positive for fibres “above” the basis line and negative for fibres “below” the basis line.

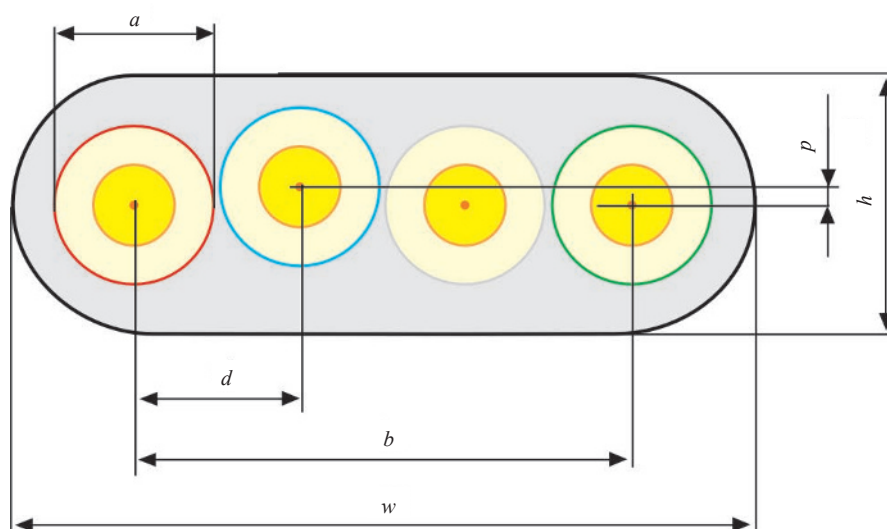

Figure 1 – Cross-sectional drawing illustrating fibre ribbon geometry

5 Method G3: Ribbon dimensions – Aperture gauge

5.1 Object

The purpose of this test is to verify the functional performance of a ribbon. In order to ensure functional performance, the dimensions of edge bonded ribbons may be controlled and verified for final inspection purposes with an aperture gauge. The intent is to verify that the end portion of a ribbon can be inserted into and would be reasonably aligned to the guide slots of commercial stripping tools. This method is under consideration for encapsulated ribbons.

5.2 Sample

Unless otherwise specified in the detail specification, five representative ribbon samples, each with a minimum length of 50 mm, shall be taken from the ribbon to be tested.

5.3 Apparatus

An aperture gauge, as shown in Figure 2, having an aperture based on the dimensions shown in IEC 60794-3:2001, Table 1, may be used to assess the overall dimensions of a ribbon.

5.4 Procedure

The ribbon sample to be tested is held in the middle and a 10 mm end portion is inserted through the aperture gauge.

5.5 Requirement

It must be possible for the 10 mm ribbon end portion to be freely inserted through the aperture gauge without mechanical damage to the sample.

5.6 Details to be specified

The detail specification shall include the following:

- a) dimensions of the aperture gauge;
- b) number of samples to be tested.

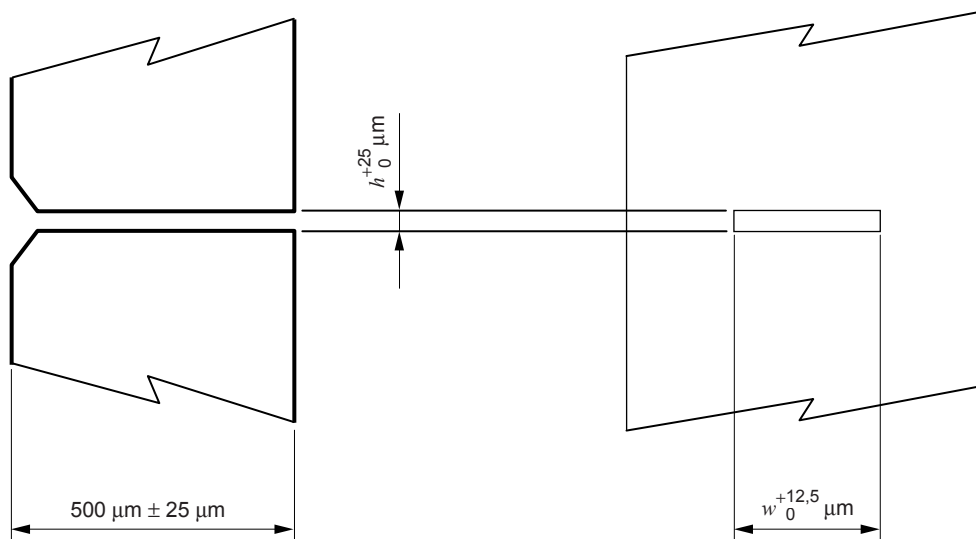

Figure 2 – Aperture gauge

6 Method G4: Ribbon dimensions – Dial gauge (Test deleted)

7 Method G5: Ribbon tear (separability)

7.1 Object

The purpose of this test is to assure sufficient tear resistance for ribbons where the fibres are not required to be separable, or to assure sufficient separability of the fibres for ribbons where the fibres are required to be separated. The intention of this test is to be able to tear by hand without damage

7.2 Sample

For an n fibre ribbon, $n/2$ specimens, each with a minimum length of 100 mm, are taken from lengths of approximately 1 m each from the fibre ribbon.

The fibres to be tested are separated with a knife or other suitable method on a suitable length for clamping (see Figure 3) for x samples (x , typically 3 to 5, to be specified in the detail specification). One fibre is separated from the other fibres in the ribbon. For x more samples, two fibres are separated from the other fibres in the ribbon, etc. up to $n/2$ fibres.

7.3 Apparatus

The apparatus consists of:

- a) a tensile strength measuring apparatus with suitable clamping devices;
- b) a microscope with at least $100\times$ magnification.

7.4 Procedure

The specimen as shown is inserted into the strength measuring apparatus, as shown in Figure 4, The fibres to be tested are torn at a speed of approximately 100 mm/min. The force to tear the fibres on a length of 50 mm is continuously recorded.

In the case where fibres are required to be separated, the primary coating of the separated fibre(s) shall be visually inspected by means of a microscope.

7.5 Requirements

The primary requirement is to be able to make the tear without fibre damage (coating damage or fibre breakage). For ribbons where the fibres are required to be separated the coloured primary coating of the separated fibre(s) shall be free from ribbon matrix residues.

Any colour coding of fibres shall remain sufficiently intact to enable individual fibres to be distinguished from each other.

The minimum or maximum and mean tear forces shall be as specified in the detail specification.

7.6 Details to be specified

The detail specification shall include the following:

- a) minimum and mean tear force, in N, when fibres are not required to be separated;
- b) maximum and mean tear force, in N, when fibres are required to be separated;
- c) number of samples;
- d) type of ribbon (separable or non-separable).

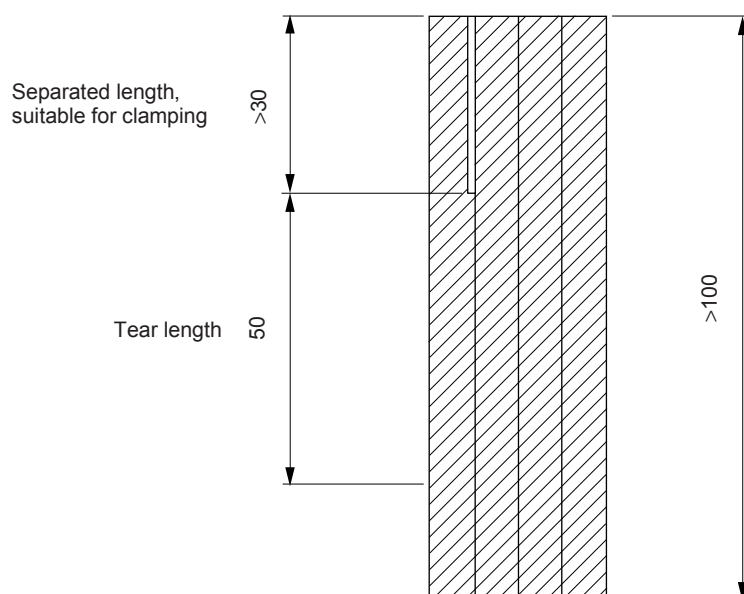

Figure 3 – Sample preparation

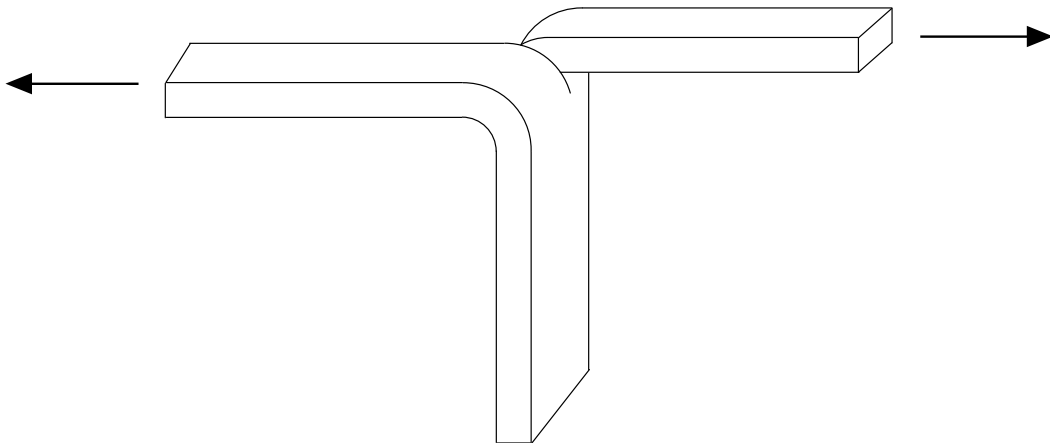

Figure 4 – Separability procedure

8 Method G6: Ribbon torsion

8.1 Object

The purpose of this test is to verify the mechanical and functional integrity of the fibre ribbon structure. The test determines the capability of the ribbon to withstand torsion without delamination, whilst maintaining the fibre separability where required.

8.2 Sample

Unless otherwise specified in the detail specification, five representative samples, each with a minimum length of 120 mm, are obtained from the ribbon to be tested.

8.3 Apparatus

The testing apparatus, an example of which is in Figure 5, consists of two vertically positioned clamps to hold the sample while it is twisted under a minimum tension of 1 N. The minimum length to be tested is 100 mm.

8.4 Procedure

The sample is securely fixed in the apparatus and twisted in increments of $180^\circ \pm 5^\circ$ within a time of 2 s. The minimum dwell time after each twist increment is 5 s. The incremental twisting is continued to the value(s) agreed upon between the manufacturer and user, as defined in the detail specification, or until delamination occurs.

8.5 Requirements

The ribbon shall withstand the number of 180° turns until delamination occurs, as given in the detail specification.

8.6 Details to be specified

The detail specification shall include the following:

- a) number of samples;
- b) number of turns.

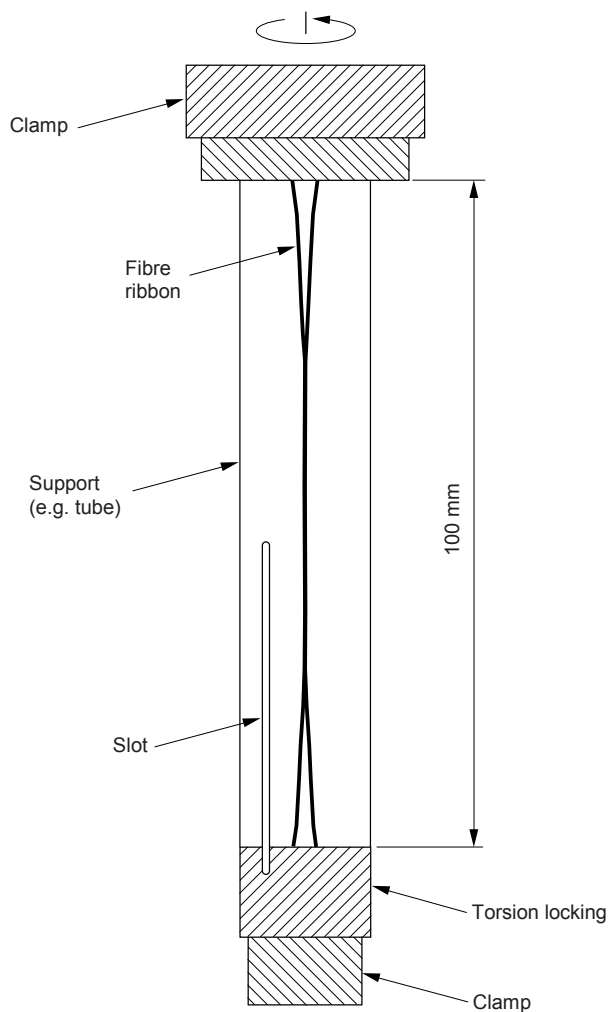

Figure 5 – Torsion test

9 Method G7: Tube kinking

9.1 Object

The purpose of this test is to determine the ability of tubes containing optical fibres to withstand mechanical stresses encountered during cable installation and splicing. The test is carried out on tubes taken from an optical cable.

9.2 Sample

Tube containing fibres, with a length of at least $L_1 + 50$ mm, taken from an optical fibre cable.

5 samples shall be tested, unless otherwise specified.

9.3 Apparatus

The apparatus consists of:

a) a testing device (see Figure 6); where:

L_1 = length of tube under test

- L_2 = distance between the tube clamping point of the movable clamp and the tube clamping point of the fixed clamp at the start of the test
- L = moving distance (the length of which determines the reduction of the ellipse dimension)

The dimensions of the apparatus are given in Table 1.

NOTE 1 The minimum diameter of the loop is not fixed by a curvature in the test equipment, but only controlled by the fixed length L_1 of the specimen and the moving length L .

NOTE 2 The fixed guideway ensures a defined position of the sample. A transparent cover allows the sample to be kept in the same plane and observed whilst being tested. The distance between the two covers shall be typically three times the tube diameter. Too great a distance will allow the tube to move sideways during the test and does not ensure that the test is severe enough.

Table 1 – Examples of test apparatus dimensions:

Nominal tube diameter	L_1	L_2
≤ 3,1 mm	350 mm	100 mm
≤ 6,1 mm	650 mm	200 mm
≤ 10,1 mm	1 050 mm	300 mm

9.4 Procedure

The test shall be carried out at standard atmospheric conditions.

The sample shall be marked with a length L_1 and mounted in the test device as shown in Figure 6, with the movable and fixed clamps separated by a distance L_2 .

The moveable clamp shall be moved between positions 1 and 2 over a distance L and returned to position 1 at a speed approximately 10 mm/s. This movement is one cycle. During the last cycle, the sample shall remain in position 2 for 60 s.

The values of test parameters L , L_1 , L_2 and the number of cycles (five, unless stated otherwise) should simulate the service deployment conditions. They shall be agreed between user and manufacturer.

NOTE 1 Whilst the loop tends to form an ellipse rather than a perfect circle during the test, it is possible to simplify the understanding of the test parameters considerably by assuming that a circle is formed. Based on this assumption, then:-

$$L = L_1 - (L_2 + \pi \times D) \quad (1)$$

Where D = the tube loop diameter (mm)

NOTE 2 As a mechanical test, a typical minimum value for the tube loop diameter is 60 mm, since this aligns with the minimum specified bend diameter for most classes of fibre and also represents a minimum practical value of coiled tube loops within a joint or other connectivity plant.

NOTE 3 Using $D = 60$ mm then L can be calculated (for tubes ≤ 3,1mm) from equation 1, which also yields the value of 60 mm. Since the loop does form an ellipse, which makes the effective loop diameter in one plane much more severe, it is recommended that 60 mm is taken as the maximum length specified for the moving length, L . Lower values may be specified.

NOTE 4 If this test is used to simulate installation of a tube within a joint, then the value for D may be replaced by the available width within a joint.

9.5 Requirements

During the test no kinking of the sample shall be visible.

9.6 Details to be specified

The detail specification shall include the following:

- number of cycles (five, unless otherwise specified);
- lengths L , L_1 , L_2 ; (use $L = 60$ mm, $L_1 = 350$ mm, $L_2 = 100$ mm, unless otherwise specified, for tubes $\leq 3,1$ mm)

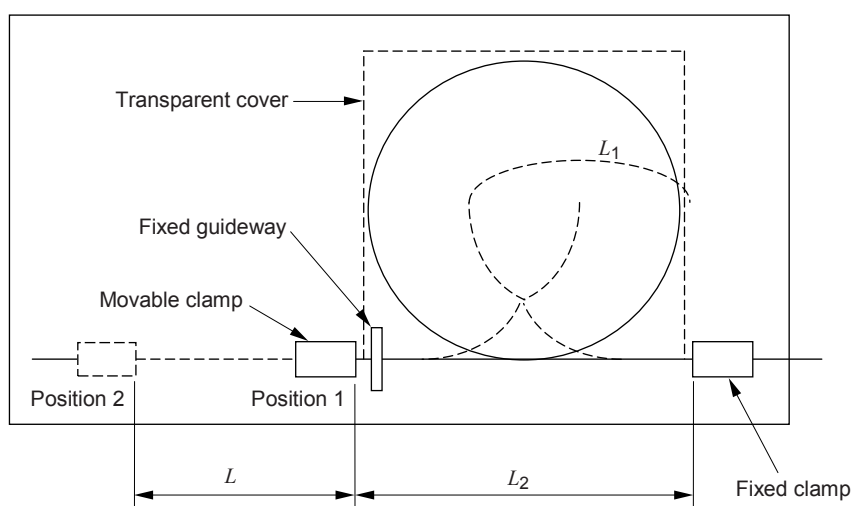

Figure 6 – Tube kinking test

10 Method G8: Ribbon residual twist test

10.1 Object

The ribbon residual twist test, or flatness test, evaluates the degree of permanent twist in a cabled optical fibre ribbon.

10.2 Sample

Ribbon samples shall be taken from a preconditioned (aged) test cable.

The samples shall be of a length sufficient to include the gauge length of 50 cm and additional length on each end to facilitate attachment of clamps and the test weight.

10.3 Apparatus

The apparatus shall be constructed to have the following characteristics:

- The ribbon shall hang vertically, clamped at the top, with the bottom end free to rotate and translate as necessary.
- A mass shall be attached to the bottom end of the ribbon sample, with the gauge length situated between the top clamp and the bottom mass.
- The bottom mass shall be arranged so that it does not impart any twisting or side loading of the ribbon.
- The gauge length shall be 50 ± 5 cm, unless otherwise specified.
- The mass shall be 100 ± 5 g, unless otherwise specified.

- A method shall be provided to measure the axial rotation of the lower end of the ribbon gauge length with respect to the upper end.

10.4 Procedure

Perform the following steps, unless otherwise specified:

- 1) Precondition the ribbon at 85 ± 2 °C, uncontrolled relative humidity, for 30 days in its cable.
- 2) Mount one end of the ribbon in the top clamp.
- 3) Attach the bottom mass.
- 4) Allow the ribbon to rotate. When the rotation settles out and the ribbon becomes still, measure the angular rotation of the bottom end of the gauge length with respect to the upper end of the gauge length.
- 5) Calculate the residual twist of the sample:

$$\text{Residual twist} = (\text{final angle, top to bottom}) / (\text{measured gauge length})$$

10.5 Requirements

The buffered fibres shall not exceed the maximum residual twist requirements of the detail specification. In most cases, a maximum residual twist of 8 degrees/cm is adequate.

10.6 Details to be specified

The detail specification shall include the following:

- a) the preconditioning conditions, if different from those stated above;
 - b) the ribbon gauge length, if different from that stated above; and
 - c) the tension mass, if different from that stated above.
-

British Standards Institution (BSI)

BSI is the independent national body responsible for preparing British Standards and other standards-related publications, information and services. It presents the UK view on standards in Europe and at the international level.

BSI is incorporated by Royal Charter. British Standards and other standardisation products are published by BSI Standards Limited.

Revisions

British Standards and PASs are periodically updated by amendment or revision. Users of British Standards and PASs should make sure that they possess the latest amendments or editions.

It is the constant aim of BSI to improve the quality of our products and services. We would be grateful if anyone finding an inaccuracy or ambiguity while using British Standards would inform the Secretary of the technical committee responsible, the identity of which can be found on the inside front cover. Similar for PASs, please notify BSI Customer Services.

Tel: +44 (0)20 8996 9001 Fax: +44 (0)20 8996 7001

BSI offers BSI Subscribing Members an individual updating service called PLUS which ensures that subscribers automatically receive the latest editions of British Standards and PASs.

Tel: +44 (0)20 8996 7669 Fax: +44 (0)20 8996 7001

Email: plus@bsigroup.com

Buying standards

You may buy PDF and hard copy versions of standards directly using a credit card from the BSI Shop on the website www.bsigroup.com/shop. In addition all orders for BSI, international and foreign standards publications can be addressed to BSI Customer Services.

Tel: +44 (0)20 8996 9001 Fax: +44 (0)20 8996 7001

Email: orders@bsigroup.com

In response to orders for international standards, BSI will supply the British Standard implementation of the relevant international standard, unless otherwise requested.

Information on standards

BSI provides a wide range of information on national, European and international standards through its Knowledge Centre.

Tel: +44 (0)20 8996 7004 Fax: +44 (0)20 8996 7005

Email: knowledgecentre@bsigroup.com

BSI Subscribing Members are kept up to date with standards developments and receive substantial discounts on the purchase price of standards. For details of these and other benefits contact Membership Administration.

Tel: +44 (0)20 8996 7002 Fax: +44 (0)20 8996 7001

Email: membership@bsigroup.com

Information regarding online access to British Standards and PASs via British Standards Online can be found at www.bsigroup.com/BSOL

Further information about British Standards is available on the BSI website at www.bsi-group.com/standards

Copyright

All the data, software and documentation set out in all British Standards and other BSI publications are the property of and copyrighted by BSI, or some person or entity that own copyright in the information used (such as the international standardisation bodies) has formally licensed such information to BSI for commercial publication and use. Except as permitted under the Copyright, Designs and Patents Act 1988 no extract may be reproduced, stored in a retrieval system or transmitted in any form or by any means – electronic, photocopying, recording or otherwise – without prior written permission from BSI. This does not preclude the free use, in the course of implementing the standard, of necessary details such as symbols, and size, type or grade designations. If these details are to be used for any other purpose than implementation then the prior written permission of BSI must be obtained. Details and advice can be obtained from the Copyright & Licensing Department.

Tel: +44 (0)20 8996 7070

Email: copyright@bsigroup.com

BSI

389 Chiswick High Road London W4 4AL UK

Tel +44 (0)20 8996 9001

Fax +44 (0)20 8996 7001

www.bsigroup.com/standards