

# Cable networks for television signals, sound signals and interactive services —

## Part 4: Passive wideband equipment for coaxial cable networks

ICS 33.060.40; 33.170

## National foreword

This British Standard is the UK implementation of EN 60728-4:2008. It is identical to IEC 60728-4:2007. It supersedes BS EN 50083-4:1999 which is withdrawn.

The UK participation in its preparation was entrusted to Technical Committee EPL/100, Audio, video and multimedia systems and equipment.

A list of organizations represented on this committee can be obtained on request to its secretary.

This publication does not purport to include all the necessary provisions of a contract. Users are responsible for its correct application.

**Compliance with a British Standard cannot confer immunity from legal obligations.**

This British Standard was published under the authority of the Standards Policy and Strategy Committee on 30 June 2008

© BSI 2008

ISBN 978 0 580 56972 2

### Amendments/corrigenda issued since publication

Date	Comments

English version

**Cable networks for television signals,  
sound signals and interactive services -  
Part 4: Passive wideband equipment for coaxial cable networks  
(IEC 60728-4:2007)**

Réseaux de distribution par câbles  
pour signaux de télévision,  
signaux de radiodiffusion sonore  
et services interactifs -  
Partie 4: Equipements large bande passifs  
relatifs aux réseaux câblés coaxiaux  
(CEI 60728-4:2007)

Kabelnetze für Fernsehsignale,  
Tonsignale und interaktive Dienste -  
Teil 4: Passive Breitbandgeräte für  
koaxiale Kabelnetze  
(IEC 60728-4:2007)

This European Standard was approved by CENELEC on 2008-04-01. CENELEC members are bound to comply with the CEN/CENELEC Internal Regulations which stipulate the conditions for giving this European Standard the status of a national standard without any alteration.

Up-to-date lists and bibliographical references concerning such national standards may be obtained on application to the Central Secretariat or to any CENELEC member.

This European Standard exists in two official versions (English and German). A version in any other language made by translation under the responsibility of a CENELEC member into its own language and notified to the Central Secretariat has the same status as the official versions.

CENELEC members are the national electrotechnical committees of Austria, Belgium, Bulgaria, Cyprus, the Czech Republic, Denmark, Estonia, Finland, France, Germany, Greece, Hungary, Iceland, Ireland, Italy, Latvia, Lithuania, Luxembourg, Malta, the Netherlands, Norway, Poland, Portugal, Romania, Slovakia, Slovenia, Spain, Sweden, Switzerland and the United Kingdom.

**CENELEC**

European Committee for Electrotechnical Standardization  
Comité Européen de Normalisation Electrotechnique  
Europäisches Komitee für Elektrotechnische Normung

**Central Secretariat: rue de Stassart 35, B - 1050 Brussels**

## **Foreword**

The text of document 100/1243/FDIS, future edition 3 of IEC 60728-4, prepared by technical area 5, Cable networks for television signals, sound signals and interactive services, of IEC TC 100, Audio, video and multimedia systems and equipment, was submitted to the IEC-CENELEC parallel vote and was approved by CENELEC as EN 60728-4 on 2008-04-01.

This European Standard supersedes EN 50083-4:1998 + corrigendum January 1999.

The following dates were fixed:

- latest date by which the EN has to be implemented  
at national level by publication of an identical  
national standard or by endorsement (dop) 2009-01-01
- latest date by which the national standards conflicting  
with the EN have to be withdrawn (dow) 2011-04-01

For this European Standard the informative Annex B of IEC 60728-4:2007 shall be disregarded and has been replaced by the normative Annex ZB, *Special national conditions*; and the informative Annex ZC, *A-deviations*.

Annexes ZA, ZB and ZC have been added by CENELEC.

---

## **Endorsement notice**

The text of the International Standard IEC 60728-4:2007 was approved by CENELEC as a European Standard without any modification.

---

## CONTENTS

INTRODUCTION.....	5
1 Scope.....	6
2 Normative references .....	6
3 Terms, definitions, symbols and abbreviations.....	7
3.1 Terms and definitions .....	7
3.2 Symbols .....	11
3.3 Abbreviations .....	12
4 Methods of measurement .....	12
4.1 Attenuation.....	12
4.1.1 Test equipment.....	12
4.1.2 Measurement procedure.....	12
4.1.3 Presentation of the results.....	13
4.2 Isolation .....	13
4.2.1 Definition.....	13
4.2.2 Test equipment.....	13
4.2.3 Measurement procedure.....	13
4.2.4 Presentation of the results.....	14
4.3 Through-loss .....	14
4.3.1 Definition.....	14
4.3.2 Test equipment.....	14
4.3.3 Measurement procedure.....	14
4.3.4 Presentation of the results.....	14
4.4 Group delay variation .....	14
4.4.1 Definition.....	14
4.4.2 Test equipment.....	14
4.4.3 Method of measurement.....	15
4.4.4 Presentation of the result.....	15
4.5 Amplitude frequency response .....	15
4.6 Return loss.....	15
4.7 Hum modulation of carrier .....	15
4.7.1 Definition.....	15
4.7.2 Description of the method of measurement.....	16
4.7.3 Measuring procedure.....	17
4.7.4 Calculating the hum-modulation ratio.....	18
4.7.5 Presentation of the results.....	19
4.8 Two-carrier intermodulation measurements for second- and third-order products.....	19
5 Performance requirements and recommendations .....	20
5.1 General performance requirements and recommendations .....	20
5.1.1 Safety.....	20
5.1.2 Electromagnetic compatibility (EMC) .....	20
5.1.3 Environmental .....	20
5.1.4 Marking .....	21
5.1.5 Impedance.....	21

5.1.6	Degradation of performance caused by overvoltages .....	21
5.2	Performance requirements and recommendations for receiver lead .....	21
5.3	Performance requirements and recommendations for system outlets .....	21
5.3.1	Safety .....	21
5.3.2	Quality grading .....	21
5.3.3	Mechanical requirements .....	22
5.3.4	Electrical parameters and requirements .....	22
5.4	Performance requirements and recommendations for splitters and taps .....	25
5.4.1	Description .....	25
5.4.2	Mechanical requirements for connectors .....	25
5.4.3	Electrical parameters and requirements .....	25
5.5	Performance requirements and recommendations for all other passive equipment .....	27
5.5.1	Description .....	27
5.5.2	Mechanical requirements for connectors .....	27
5.5.3	Electrical parameters and requirements .....	27
	Bibliography .....	31
	Annex A (informative) Measurement errors which occur due to mismatched equipment .....	29
	Annex B (informative) Differences in some countries .....	30
	Annex ZA (normative) Normative references to international publications with their corresponding European publications .....	32
	Annex ZB (normative) Special national conditions .....	34
	Annex ZC (informative) A-deviations .....	35
	Figure 1 – Test set-up for the measurement of attenuation .....	13
	Figure 2 – Test set-up for the measurement of isolation .....	13
	Figure 3 – Measurement of through-loss .....	14
	Figure 4 – Carrier/hum ratio .....	15
	Figure 5 – Test set-up for power injectors .....	16
	Figure 6 – Test set-up for passive equipment, excluding power injectors .....	17
	Figure 7 – Oscilloscope display .....	17
	Figure 8 – Harmonic/Intermodulation test circuit .....	19
	Figure 9 – Types of losses of system outlets .....	24
	Figure A.1 – Error concerning return loss measurement .....	29
	Figure A.2 – Maximum ripple .....	29
	Table 1 – Return loss of system outlets .....	22
	Table 2 – Return loss of looped-through system outlets .....	23
	Table 3 – Maximum return path signal level derived from maximum allowed intermodulation distortion level in the downstream frequency band .....	25
	Table 4 – Return loss of splitters and taps .....	25
	Table 5 – Isolation of splitters .....	26
	Table 6 – Return loss for all other passive equipment .....	27

## INTRODUCTION

Standards of the IEC 60728 series deal with cable networks including equipment and associated methods of measurement for headend reception, processing and distribution of television signals, sound signals and their associated data signals and for processing, interfacing and transmitting all kinds of signals for interactive services using all applicable transmission media.

This includes

- CATV<sup>1</sup>-networks;
- MATV-networks and SMATV-networks;
- individual receiving networks;

and all kinds of equipment, systems and installations installed in such networks.

The extent of this standardization work is from the antennas and/or special signal source inputs to the headend or other interface points to the network up to the terminal input.

The standardization of any user terminals (i.e., tuners, receivers, decoders, multimedia terminals, etc.) as well as of any coaxial, balanced and optical cables and accessories thereof is excluded.

---

<sup>1</sup> This word encompasses the HFC networks used nowadays to provide telecommunications services, voice, data, audio and video both broadcast and narrowcast.

## CABLE NETWORKS FOR TELEVISION SIGNALS, SOUND SIGNALS AND INTERACTIVE SERVICES –

### Part 4: Passive wideband equipment for coaxial cable networks

#### 1 Scope

This part of IEC 60728 applies to system outlets, splitters and taps, passive single or multiple port equipment comprising filters, attenuators, equalizers, galvanic isolators, power injectors, cable splices, terminating resistors and transfer points, but excluding coaxial cables and receiver leads (see 5.2).

This standard

- covers the frequency range 5 MHz to 3 000 MHz;
- identifies performance requirements for certain parameters;
- lays down data publication requirements for certain parameters;
- stipulates methods of measurements;
- introduces minimum requirements defining quality grades.

There are three grades for all passive equipment except system outlets where there is only one.

Different networks require the same performance and, when integrating networks, upgrading will be avoided.

Practical experience has shown that these three grades meet most of the technical requirements necessary for supplying a minimum signal quality to the subscribers. This classification should not be considered as a requirement but as information for users and manufacturers on the minimum quality criteria of the material required to install networks of different sizes. The system operator should select appropriate material to meet the minimum signal quality at the subscriber's outlet and to optimize cost/performance, taking into account the size of the network and local circumstances.

All requirements and published data should be understood as guaranteed values within the specified frequency range and in well-matched conditions.

#### 2 Normative references

The following referenced documents are indispensable for the application of this document. For dated references, only the edition cited applies. For undated references, the latest edition of the referenced document (including any amendments) applies.

IEC 60068 (all parts), *Environmental testing*

IEC 60417, *Graphical symbols for use on equipment*

NOTE IEC 60417 can be consulted on the IEC website.

IEC 60529, *Degrees of protection provided by enclosures (IP Code)*



IEC 60617, *Graphical symbols for diagrams*

IEC 60728 (all parts), *Cable networks for television signals, sound signals and interactive services*

NOTE The title of some of the parts of the IEC 60728 series will be changed when a new edition is published.

IEC 60966-1, *Radio frequency and coaxial cable assemblies – Part 1: Generic specification – General requirements and test methods*

IEC 60966-2-4, *Radio frequency and coaxial cable assemblies – Part 2-4: Detail specification for cable assemblies for radio and TV receivers – Frequency range 0 to 3 000 MHz, IEC 61169-2 connectors*

IEC 60966-2-5, *Radio frequency and coaxial cable assemblies – Part 2-5: Detail specification for cable assemblies for radio and TV receivers – Frequency range 0 to 1 000 MHz, IEC 61169-2 connectors*

IEC 60966-2-6, *Radio frequency and coaxial cable assemblies – Part 2-6: Detail specification for cable assemblies for radio and TV receivers – Frequency range 0 to 3 000 MHz, IEC 61169-24 connectors*

IEC 61000-4-5, *Electromagnetic compatibility (EMC) – Part 4-5: Testing and measurement techniques – Surge immunity test*

IEC 61000-6-1, *Electromagnetic compatibility (EMC) – Part 6-1: Generic standards – Immunity for residential, commercial and light-industrial environments*

IEC 61169-1, *Radio-frequency connectors – Part 1: Generic specification – General requirements and measuring methods*

IEC 61169-2, *Radio-frequency connectors – Part 2: Sectional specification – Radio-frequency coaxial connectors of type 9,52*

IEC 61169-24, *Radio-frequency connectors – Part 24: Sectional specification – Radio-frequency coaxial connectors with screw coupling, typically for use in 75 ohm cable distribution systems (type F)*

### **3 Terms, definitions, symbols and abbreviations**

#### **3.1 Terms and definitions**

For the purposes of this document, the following terms and definitions apply.

NOTE Some terms have been taken from IEC 60050-723.

##### **3.1.1**

##### **active equipment**

equipment (for example, amplifiers, converters, etc), performing signal processing by means of external or internal power supply in a certain frequency range

##### **3.1.2**

##### **amplitude frequency response**

gain or loss of an equipment or system plotted against frequency

**3.1.3****attenuation**

ratio of the input power to the output power of an equipment or system, usually expressed in decibels

**3.1.4****decibel ratio**

ten times the logarithm of the ratio of two quantities of power,  $P_1$  and  $P_2$ , i.e.

$$10 \lg \frac{P_1}{P_2} \text{ dB} \quad (1)$$

**3.1.5****directional coupler****tap**

passive signal splitting equipment, with minimum signal loss between the input port and the output port (through-loss), a specified coupling loss between the input port and the tap port (tap loss), and very high loss between the output port and tap port (isolation)

[IEV 723-09-25, modified]

**3.1.6****directivity**

attenuation between output port and interface or tap port, minus the attenuation between input and interface or tap port, of any equipment or system

**3.1.7****EM-active equipment**

all passive and active equipment carrying RF signals are considered as EM-active equipment, either because they are liable to cause electromagnetic disturbances or because the performance of them is liable to be affected by such disturbances

**3.1.8****equalizer**

equipment designed to compensate over a certain frequency range for the amplitude/frequency distortion or phase/frequency distortion introduced by feeders or equipment

NOTE This equipment is for the compensation of linear distortions only.

**3.1.9****feeder**

transmission path forming part of a cable network. Such a path may consist of a metallic cable, optical fibre, wave guide or any combination of them. By extension, the term is also applied to paths containing one or more radio links

[IEV 723-09-12, modified]

**3.1.10****grade**

classification of performance for equipment for use in cable networks. The choice of the appropriate grade depends on, for example,

- size of network;
- structure of network;
- lengths of cable between equipment;
- kind of services;

- kind of signals

NOTE In any case, the system performance requirement should be fulfilled by the design of the network and the choice of the grade of equipment used.

### 3.1.11 group delay variation

indicates the deviation from a linear phase-frequency response; the group delay is

$$\tau = \frac{d\varphi}{df} \quad (2)$$

where

$\varphi$  is the phase;

$f$  is the frequency.

Group delay variation (typically in ns) is the difference of the values of  $\tau$  between the given frequency and the reference frequency

### 3.1.12 isolation

attenuation between two output, tap or interface ports of any equipment or system

### 3.1.13 level

level of any power  $P_1$  is the decibel ratio of that power to the standard reference power  $P_0$ , i.e.

$$10 \lg \frac{P_1}{P_0} \quad (3)$$

level of any voltage  $U_1$  is the decibel ratio of that voltage to the standard reference voltage  $U_0$ , i.e.

$$20 \lg \frac{U_1}{U_0} \quad (4)$$

NOTE This may be expressed in decibels (relative to 1  $\mu\text{V}$  in 75  $\Omega$ ) or more simply in dB( $\mu\text{V}$ ) if there is no risk of ambiguity.

### 3.1.14 looped system outlet

device through which the spur feeder passes and to which is connected a receiver lead, without the use of a subscriber's feeder

[IEV 723-09-21]

### 3.1.15 nominal value

reference value around which a certain tolerance field (plus/minus) is permitted or specified

### 3.1.16 passive equipment

equipment (for example, splitters, tap-offs, system outlets, etc.) not requiring a power supply in order to operate and/or not carrying out signal processing in a certain frequency range

**3.1.17****receiver lead**

lead which connects the system outlet to the subscriber equipment

[IEV 723-09-23, modified]

NOTE 1 The meaning of receiver lead may not describe the function of this device if it is used for interactive subscriber equipment; the definition already gives the more general explanation and allows bi-directional services.

NOTE 2 A receiver lead may include filters and balun transformers in addition to the cable.

**3.1.18****r.f. data port**

r.f. interface port to connect an interactive data equipment (for example, a modem) and passes return band (upstream), as well as distribution (downstream) frequency band

**3.1.19****splice**

connecting device with barrel(s) accommodating electrical conductor(s) with or without additional provision to accommodate and secure the insulation

[IEV 581-05-11]

**3.1.20****splitter**

equipment in which the signal power at the (input) port is divided equally or unequally between two or more (output) ports

NOTE This equipment may be used in the reverse direction for combining signal energy.

**3.1.21****spur feeder**

feeder to which splitters, subscriber taps or looped system outlets are connected

[IEV 723-09-16, modified]

**3.1.22****standard reference power and voltage**

in cable networks the standard reference power,  $P_0$ , is 1/75 pW

NOTE This is the power dissipated in a 75  $\Omega$  resistor with an r.m.s voltage drop of 1  $\mu$ V across it.

The standard reference voltage,  $U_0$ , is 1  $\mu$ V.

**3.1.23****subscriber feeder**

feeder connecting a subscriber tap to a system outlet or, where the latter is not used, direct to the subscriber equipment

[IEV 723-09-17, modified]

NOTE A subscriber feeder may include filters and balun transformers.

**3.1.24****subscriber tap**

equipment with one or more ports for connecting a subscriber feeder to a spur feeder

**3.1.25****system outlet**

equipment for interconnecting a cable network and a receiver lead

**3.1.26  
transfer point**

interface between the cable network and the internal network of the building, each of which may be separately owned. The transfer point may contain a voltage-dependent device and/or a galvanic isolator

**3.1.27  
well-matched**

















matching condition when the return loss of the equipment is sufficient that the expected error can be neglected

NOTE Through mismatching of measurement instruments and the measurement object, measurement errors are possible. Comments on the estimation of such errors are given in Annex A.

**3.2 Symbols**

The following graphical symbols are used in the figures of this standard. These symbols are either listed in IEC 60617 or based on symbols defined in IEC 60617.

NOTE Numbers in brackets ([ ]) refer to symbols in IEC 60617 database.

Symbol	Terms	Symbol	Terms
	voltmeter [IEC 60617-S00059(2001:07)] [IEC 60617-S00913(2001:07)]		oscilloscope [IEC 60617-S00059(2001:07)], [IEC 60617-S00922(2001:07)]
	ampere meter [IEC 60617-S00059(2001:07)] [IEC 60617-S00910(2001:07)]		spectrum analyser [IEC 60617-S00059(2001:07)] [IEC 60617-S00910(2001:07)]
	variable generator [IEC 60617-S00081(2001:07)] [IEC 60617-S01225(2001:07)] [IEC 60617-S01403(2001:09)]		detector with LF-amplifier [IEC 60617-S00118] [IEC 60617-S01239]
	equipment under test [IEC 60617-S00059(2001:07)]		adjustable a.c. voltage source
	system outlet		low pass filter [IEC 60617-S01248(2001:07)]
	looped through system outlet		high pass filter [IEC 60617-S01247(2001:07)]
	variable attenuator [IEC 60617-S01245(2001:07)]		r.f. choke [IEC 60617-S00583(2001:07)]
	ground [IEC 60617-S00200(2001:07)]		variable resistor [IEC 60617-S00557(2001:07)]
	capacitor [IEC 60617-S00567(2001:07)]		

### 3.3 Abbreviations

AC	alternating current
AM	amplitude modulation
CATV	community antenna television (system)
dBc	dBc means dB in relation to carrier level
DC	direct current
EM	electromagnetic
EMC	electromagnetic compatibility
EUT	equipment under test
FM	frequency modulation
HP	high pass
IP Class	international protection class
LF	low frequency
LP	low pass
MATV	master antenna television (system)
Q grade(s)	quality grade(s)
RF	radio frequency
RMS	root mean square
SMATV	satellite master antenna television (system)
TV	television

## 4 Methods of measurement

### 4.1 Attenuation

#### 4.1.1 Test equipment

The following test equipment is required:

- tuneable r.f. signal generator;
- variable calibrated attenuator;
- r.f. switch;
- spectrum analyser or selective voltmeter.

NOTE This test set is used as the basic method of measurement; normally, a network analyser is used.

#### 4.1.2 Measurement procedure

The equipment shall be connected as shown in Figure 1. Both r.f. switches shall be set to position A. The variable attenuator shall be adjusted until a reference line on the spectrum analyser or a reference value on the selective voltmeter is met. The value  $a_1$  in dB of the variable attenuator shall be read. Both r.f. switches shall be set to position B. The variable attenuator shall be adjusted until the reference (line) is met again. The value  $a_2$  in dB of the variable attenuator shall be read.

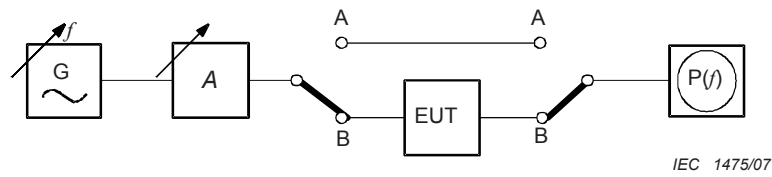

Figure 1 – Test set-up for the measurement of attenuation

The attenuation in dB of the EUT for the chosen frequency is  $a_1 - a_2$ . This procedure shall be repeated at all relevant frequencies for the EUT.

**4.1.3 Presentation of the results**

The attenuation of the EUT is expressed in dB, with reference to the chosen frequencies.

**4.2 Isolation**

**4.2.1 Definition**

The isolation measured in dB is the attenuation ratio between two outputs of a component if the signal is inserted in one of these outputs.

**4.2.2 Test equipment**

The following test equipment is required:

- tuneable RF signal generator;
- variable calibrated attenuator;
- spectrum analyser or selective voltmeter;
- RF switch.

NOTE This test set is used as the basic method of measurement; normally, a network analyser is used

**4.2.3 Measurement procedure**

The equipment shall be connected as shown in Figure 2. Both RF switches shall be set to position A. The variable attenuator shall be adjusted until a reference line on the spectrum analyser or a reference value on the selective voltmeter is met. The value  $a_1$  in dB of the variable attenuator shall be read. Both RF switches shall be set to position B. The variable attenuator shall be adjusted until the reference line is met again. The value  $a_2$  in dB of the variable attenuator shall be read. The signal shall be inserted into output port 2, the detector connected to output port 1 and the procedure repeated.

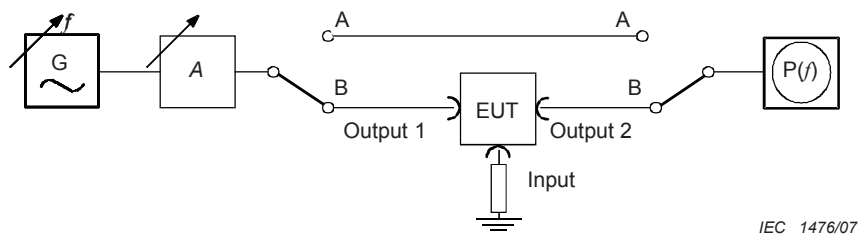

Figure 2 – Test set-up for the measurement of isolation

The isolation in dB of the EUT for the chosen frequency is  $a_1 - a_2$ . This procedure shall be repeated at all relevant frequencies for the EUT.

#### 4.2.4 Presentation of the results

The isolation of the EUT is expressed in dB with reference to the chosen frequencies.

### 4.3 Through-loss

#### 4.3.1 Definition

The through-loss, measured in dB, is the difference in signal level between the input and the looped-through output of the equipment.

#### 4.3.2 Test equipment

The following test equipment is required:

- tuneable r.f. signal generator;
- variable calibrated attenuator;
- r.f. switch;
- spectrum analyser or selective voltmeter.

NOTE This test set is used as the basic method of measurement; normally, a network analyser is used

#### 4.3.3 Measurement procedure

The equipment shall be connected as shown in Figure 3. Both r.f. switches shall be set to position A. The variable attenuator shall be adjusted until a reference line on the spectrum analyser or a reference value on the selective voltmeter is met. The value  $a_1$  in dB of the variable attenuator shall be read. Both r.f. switches shall be set to position B. The variable attenuator shall be adjusted until the reference (line) is met again. The value  $a_2$  in dB of the variable attenuator shall be read.

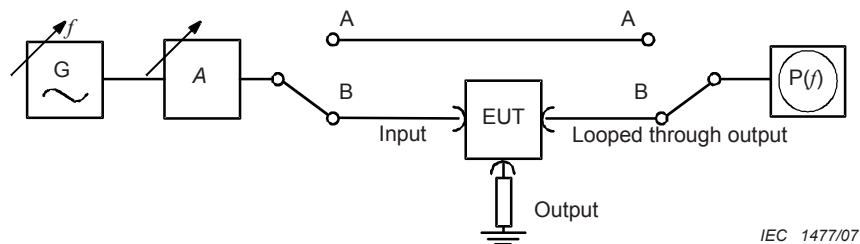

**Figure 3 – Measurement of through-loss**

The insertion loss in dB of the EUT for the chosen frequency is  $a_1 - a_2$ .

#### 4.3.4 Presentation of the results

The insertion loss of the EUT is expressed in dB, with reference to the chosen frequency.

### 4.4 Group delay variation

#### 4.4.1 Definition

Group delay variation is defined as the deviation from a linear phase-frequency response.

#### 4.4.2 Test equipment

A network analyser is required.



#### 4.4.3 Method of measurement

For the measurement of group delay, a network analyser shall be used. To ensure a reliable test result, the instructions of the test set manufacturer shall be met.

The phase shift is expressed as group delay by means of the formula:

$$\tau_g = \frac{\Delta\varphi}{360^\circ \cdot f_m} \quad (5)$$

where

$\Delta\varphi$  is the phase difference in degrees;

$f_m$  is the frequency of the test signal in Hertz;

$\tau_g$  is the group delay in seconds.

The group delay variation is determined by using the formula above or is read directly on the commercial measuring instrument.

#### 4.4.4 Presentation of the result

The group delay variation is expressed in ns in the frequency range of the EUT.

#### 4.5 Amplitude frequency response

For the measurement method of amplitude frequency response, see 4.1. The amplitude response of an equipment or system is presented as  $a_1 - a_2$ , plotted against frequency.

#### 4.6 Return loss

Return-loss measurements shall be carried out as laid down in IEC 60728-3. Unused ports shall be well-matched in 75  $\Omega$  or open/shorted if required.

#### 4.7 Hum modulation of carrier

##### 4.7.1 Definition

The interference ratio for hum modulation is the ratio stated in dB between the peak-to-peak value of the unmodulated carrier and the peak-to-peak variation  $a$  of the envelope around the carrier  $A$  caused by the hum modulating this carrier, i.e.

$$\text{carrier/hum ratio} = 20 \lg \frac{A}{a} \text{ [dB]}$$

Figure 4 illustrates the definition of the hum modulation of a carrier.

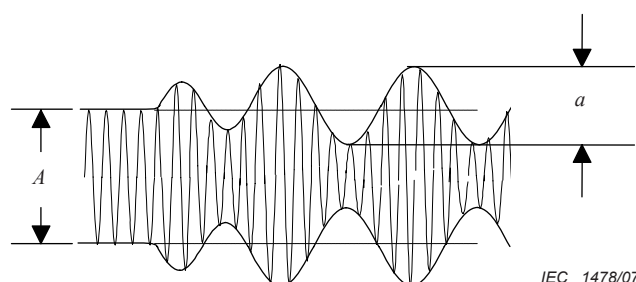

Figure 4 – Carrier/hum ratio

## 4.7.2 Description of the method of measurement

### 4.7.2.1 General

This measurement method is valid for radio and TV signal equipment within a cable network that is supplied with 50 Hz a.c..

For measuring purposes, sinusoidal signals are used. Taking into account the maximum admissible voltage or the maximum admissible current, the worst value for the operating frequency range shall be published.

NOTE For cable networks, the peak value of the supply voltage or of the supply current can be higher than the value resulting from calculation using the corresponding waveform factor.

For measurement an oscilloscope method is used.

### 4.7.2.2 Test equipment

The following test equipment is required:

- adjustable voltage source;
- variable load resistor;
- power inserter;
- variable calibrated attenuator;
- oscilloscope;
- voltmeter (r.m.s.);
- ampere meter;
- tuneable r.f. signal generator with sufficient phase-noise and hum-modulation ratio, including AM capability (400 Hz);
- detector including (battery-powered) low-frequency amplifier and 1 kHz LP filter in the output, to suppress low-frequency distortion (an HP-filter at the input shall be used).

### 4.7.2.3 Connection of test equipment

The connection scheme for locally powered EUT is shown in Figure 5; the connection scheme for remotely powered EUT is shown in Figure 6.

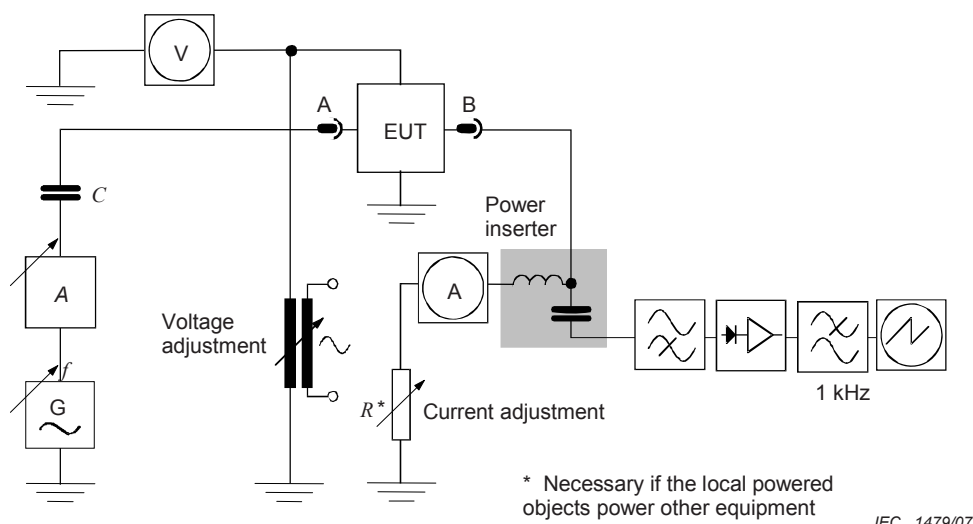

Figure 5 – Test set-up for power injectors

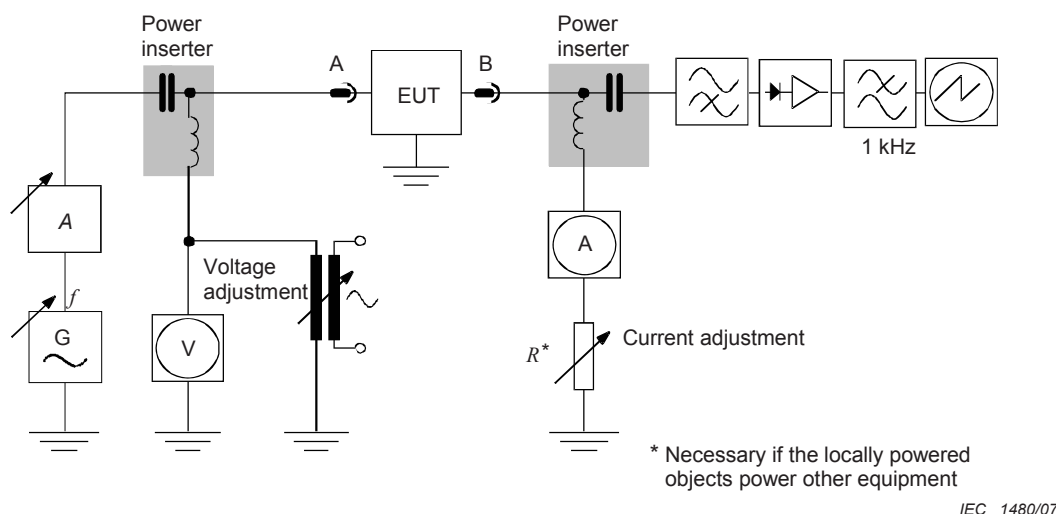

Figure 6 – Test set-up for passive equipment, excluding power injectors

4.7.3 Measuring procedure

4.7.3.1 Set-up of calibration

The reference signal is generated by means of the RF signal generator shown in Figure 5 and Figure 6. An r.f. carrier frequency that suits the TV channel under consideration shall be chosen and modulated to a depth of 1 % at a frequency of 400 Hz. The r.f. signal generator shall be adjusted to an appropriate level and the peak-to-peak value of the demodulated AM signal (*c* in Figure 7) read on the oscilloscope. This is the reference signal. With 1 % modulation this value is:

$$-20 \lg (0,01) = 40 \text{ dB} \tag{6}$$

The modulation of the signal generator shall be switched off. The remaining value, *m*, in Figure 7 is the value to be measured.

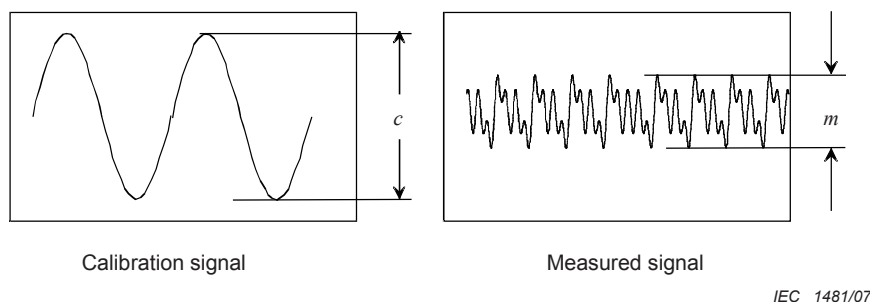

Figure 7 – Oscilloscope display

The suitability of the measuring set-up shall be checked by connecting points A and B together and measuring the inherent hum of the set-up. The calculation of the hum-modulation ratio is given in 4.7.4. This value should be at least 10 dB better than the values to be measured on items of equipment. For measurements with set-up for locally powered EUT, the set-up shown in Figure 5 shall be used for check. The subsequent measurements shall be carried out in suitable increments through the entire operating frequency range. The measured value is independent of the r.f. level; however, the r.f. level should be at least the magnitude of the EUT operating level.

#### 4.7.3.2 Locally powered EUT

The EUT shall be adjusted to maximum or minimum operating voltage using the transformer. The supply current depends on the power requirement of the EUT.

The signal generator shall be modulated with the reference signal and the level at point B shall be adjusted by means of an attenuator in such a way that neither the EUT is overdriven nor the detector is within a non-admissible operating range. The peak-to-peak amplitude,  $c$ , of the demodulated reference signal, which is displayed on the oscilloscope, shall be noted. Then the reference signal shall be switched off and the peak-to-peak value,  $m$ , of the remaining signal measured.

In addition, for EUT with remote supply terminals, the maximum admissible peak current for the respective terminal shall be adjusted by means of resistor R.

#### 4.7.3.3 Remotely supplied EUT

For remotely supplied EUT, the general procedure described in 4.7.3.2 shall be followed. The only difference is that the supply energy is routed to the equipment via an r.f. terminal. In the case where there are several r.f. interfaces available for power insertion, each of these interfaces shall be included in the measurement procedure in a suitable manner.

#### 4.7.4 Calculating the hum-modulation ratio

##### 4.7.4.1 Frequency range

The frequency range considered for the hum is from 50 Hz to 1 kHz.

##### 4.7.4.2 Individual EUT

The hum-modulation ratio [EUT] is equal to  $40 \text{ dB} + 20 \lg (c/m) \text{ [dB]}$  for 1 % reference modulation depth.

For other chosen reference modulation depths, the value 40 dB shall be replaced by the result of the term  $-20 \lg (\text{modulation depth})$ .

##### 4.7.4.3 Cascaded EUT

For high hum-modulation ratios, it can be useful to cascade several EUT for better determination of the measuring values. Then, to calculate the individual EUT, the following formula shall be used.

$$\text{Hum-modulation ratio [EUT]} = \text{Hum-modulation ratio [cascaded]} + 20 \lg n \text{ [dB]}$$

where

$n$  is the number of cascaded EUT.

##### 4.7.4.4 Loop-value correction

If a set-up calibration correction is required, the following formula shall be used.

$$\text{Hum-modulation ratio [EUT]} = -20 \lg \left( 10^{-\frac{\text{measured value}}{20}} - 10^{-\frac{\text{calibration correction}}{20}} \right) \text{ [dB]} \quad (7)$$

#### 4.7.5 Presentation of the results

The hum-modulation ratio is expressed in dB.

#### 4.8 Two-carrier intermodulation measurements for second- and third-order products

Splitters, taps and directional couplers contain ferrite transformers. These transformers are non-linear and produce harmonic and intermodulation products.

These are predominately third-order products and are insignificant (greater than 120 dBc), providing the ferrite cores are not magnetised. If the cores become magnetized then significant second-order products may be produced. Third harmonic products remain low.

Ferrite transformers saturate easily when subjected to d.c. or pulse voltages. A typical splitter input transformer will saturate in less than 10 V/ $\mu$ s. Following this saturation, the core will remain magnetized.

It is not possible to stop equipment becoming magnetized in the CATV environment.

In order to carry out harmonic or intermodulation tests, it is therefore necessary to magnetize equipment prior to test in order to simulate worst-case conditions. The surge immunity test described in 5.1.6.2 provides adequate magnetization and may be used to precondition the equipment under test.

As an alternative to the surge immunity test, a 25 V/500  $\mu$ s pulse should be applied to each port via a 300  $\Omega$  source impedance prior to testing.

In circuits each ferrite core appears as a coherent harmonic generator with a source impedance determined by the relevant circuit elements. It is thus imperative that all of the equipment ports are correctly terminated at all frequencies to enable correct measurements to be taken.

For splitters and taps, the return path signal is applied to each output port  $OP_x$  and measurements are taken at either or both output ports via diplex filters (see Figure 8). The harmonic signal present at the input port IP is of no significance.

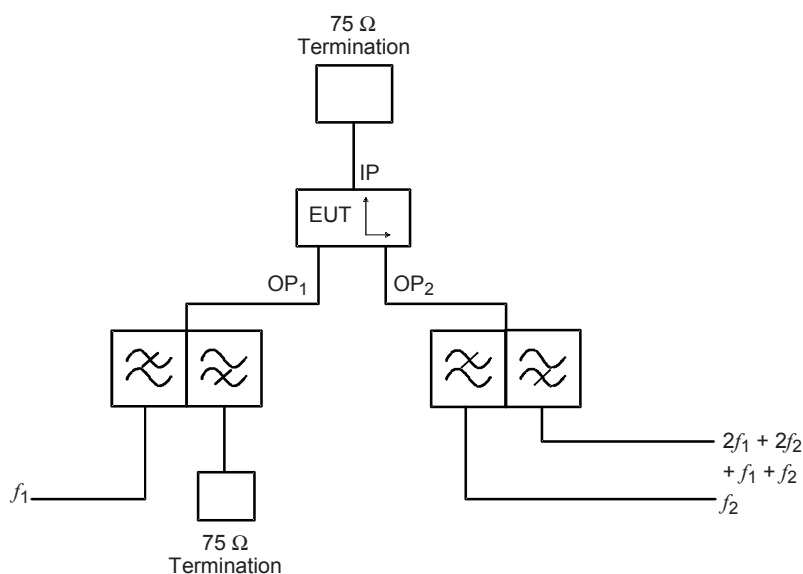

IEC 1482/07

Figure 8 – Harmonic/Intermodulation test circuit

Values for  $f_1$  and  $f_2$  are given in Table 3. Compensation should be made for the insertion loss of the diplexers, which typically should have less than 1 dB loss at  $f_2$  and  $2 \cdot f_2$  and a stop-band loss greater than 80 dB. The crossover frequency should be approximately  $\sqrt{2 \cdot f_1 \cdot f_2}$ .

## 5 Performance requirements and recommendations

### 5.1 General performance requirements and recommendations

#### 5.1.1 Safety

The relevant safety requirements as laid down in IEC 60728-11 shall be met.

#### 5.1.2 Electromagnetic compatibility (EMC)

The relevant EMC requirements laid down in IEC 60728-2 shall be met. The EMC class A or B shall be published. It is recommended that “Class A” or “Class B” be indicated on the product.

#### 5.1.3 Environmental

Manufacturers shall publish relevant environmental information on their products in accordance with the requirements of the following publications.

##### Storage

(simulated effects of) IEC 60068-2-48

##### Transportation

Air freight (combined cold and low pressure) IEC 60068-2-40

Road transport (bump test) IEC 60068-2-29

Road transport (shock test) IEC 60068-2-27

##### Installation or maintenance

Topple or drop test IEC 60068-2-31

Free fall test IEC 60068-2-32

##### Operation

IP Class. Protection provided by enclosures IEC 60529

Climatic category of component or equipment for storage and operation as defined in Annex A of IEC 60068-1

Cold IEC 60068-2-1

Dry heat IEC 60068-2-2

Damp heat IEC 60068-2-30

Change of temperature (Test Nb) IEC 60068-2-14

Vibration (sinusoidal) Annex B of IEC 60068-2-6

NOTE For requirements in Finland, see Clause B.1.

This will enable users to judge the suitability of the product with regard to four main requirements: storage, transportation, installation, and operation.

#### **5.1.4 Marking**

##### **5.1.4.1 Marking of equipment**

Each piece of equipment shall be legibly and durably marked with the manufacturer's name and type number.

##### **5.1.4.2 Marking of ports**

It is recommended that symbols in accordance with IEC 60417 should be used when marking ports.

#### **5.1.5 Impedance**

The nominal impedance of all passive equipment shall be 75  $\Omega$ .

#### **5.1.6 Degradation of performance caused by overvoltages**

##### **5.1.6.1 Introduction**

Surges caused by overvoltages from switching and lightning transients may degrade the performance of passive equipment.

For products with surge protection the manufacturer shall indicate "surge-proof" in the product information and in the data sheet. For this equipment, the following requirements shall be met.

##### **5.1.6.2 Surge immunity**

Passive equipment used at the subscriber premises and the spur feeder shall comply with performance criterion B (according to IEC 61000-6-1) after a surge voltage of 1 kV according to IEC 61000-4-5 (class 2, test level 2) has been applied. It shall be applied between the inner and the outer conductor of each port.

##### **5.1.6.3 Degradation of intermodulation performance**

After the test according to 5.1.6.2, the intermodulation requirements as specified in 5.3.4.8 (system outlets) and 5.4.3.10 (splitters and taps) should still be met.

#### **5.2 Performance requirements and recommendations for receiver lead**

The performance requirements and recommendations for receiver leads are stated in IEC 60966-1, IEC 60966-2-4, IEC 60966-2-5 and IEC 60966-2-6.

#### **5.3 Performance requirements and recommendations for system outlets**

##### **5.3.1 Safety**

Safety isolation can be incorporated in the system outlet and may be a requirement of local regulations. The isolation shall meet the requirements of IEC 60728-11 for isolated system outlets.

##### **5.3.2 Quality grading**

There is only one quality grade.

### 5.3.3 Mechanical requirements

#### 5.3.3.1 Conduit box

The system outlet shall be compatible with the conduit box used, which may be nationally or internationally standardized.

#### 5.3.3.2 Interface ports

An IEC 61169-2 male connector shall be used for the TV interface port. An IEC 61169-2 female connector shall be used for the radio interface port.

These connectors shall conform to IEC 61169-1. As an alternative, female F-connectors in accordance with IEC 61169-24 may be used.

### 5.3.4 Electrical parameters and requirements

#### 5.3.4.1 Definitions

For outlets with integral filters, a relaxation of 3 dB in return loss and isolation requirements is permissible in the pass-band edges. The pass-band edge is defined to be 8 MHz above the lower and 8 MHz below the upper cut-off frequencies for AM-TV and, respectively, 30 MHz for FM-TV, 4 MHz for FM-radio and 2 MHz for return path.

#### 5.3.4.2 Return loss

The minimum return loss shall be according to Table 1 and Table 2.

**Table 1 – Return loss of system outlets**

Port	Frequency range	Requirement
Input	5 MHz to 10 MHz	Shall be published
	10 MHz to 47 MHz	≥14 dB
	47 MHz to 950 MHz	≥(14 dB – 1,5 dB/octave) but ≥10 dB ≥10 dB in 87,5 to 108 MHz range
	950 MHz to 3 000 MHz	≥10 dB decreasing linearly to 6 dB
TV	47 MHz to 950 MHz	≥(14 dB – 1,5 dB/octave), but ≥10 dB <sup>a</sup>
FM radio	87,5 MHz to 108 MHz	≥10 dB
RF data	5 MHz to 10 MHz	Shall be published
	10 MHz to 47 MHz	≥14 dB
	47 MHz to 950 MHz	≥(14 dB – 1,5 dB/octave) but ≥10 dB
	950 MHz to 3 000MHz	≥10 dB decreasing linearly to 6 dB
Satellite	950 MHz to 3 000 MHz	≥10 dB decreasing linearly to 6 dB
<sup>a</sup> Recommended minimum value 10 dB up to 950 MHz.		
NOTE The specifications in Table 1 are not applicable for system outlets in Japan (see Clause B.3).		



**Table 2 – Return loss of looped-through system outlets**

Port	Frequency range	Requirement
Input	5 MHz to 10 MHz	Shall be published
	10 MHz to 47 MHz	≥18 dB
	47 MHz to 950 MHz	≥18 dB – 1,5 dB/octave
	950 MHz to 3 000 MHz	≥10 dB decreasing linearly to 6 dB
Output (looped through)	5 MHz to 10 MHz	Shall be published
	10 MHz to 47 MHz	≥18 dB
	47 MHz to 950 MHz	≥(18 dB – 1,5 dB/octave)
	950 MHz to 3 000 MHz	≥10 dB decreasing linearly to 6 dB
TV	47 MHz to 950 MHz	≥(14 dB – 1,5 dB/octave), but ≥10 dB
FM radio	87,5 MHz to 108 MHz	≥10 dB
RF data	5 MHz to 10 MHz	Shall be published
	10 MHz to 47 MHz	≥14 dB
	47 MHz to 950 MHz	≥(14 dB – 1,5 dB/octave) but ≥10 dB
	950 MHz to 3 000MHz	≥10 dB decreasing linearly to 6 dB
Satellite	950 MHz to 3 000 MHz	≥10 dB decreasing linearly to 6 dB
NOTE 1 The specifications in Table 2 are not applicable for system outlets in Japan (see Clause B.3).		
NOTE 2 For requirements in the Netherlands, see Clause B.2		

NOTE If two independent cable modems according to the DOCSIS specification are connected to one system outlet, second-order intermodulation products caused by the cable modems should be not higher than 6 dB(µV), taking into account a signal level of 120 dB(µV) injected by the cable modems.

For looped-through system outlets, the input return loss in the frequency range from 10 MHz to 950 MHz shall be at least 10 dB, decreasing linearly to 6 dB at 3 000 MHz, with the interface ports either open- or short-circuited.

#### 5.3.4.3 Frequency range

The operating frequency range of the system outlet shall be published.

#### 5.3.4.4 Losses

The nominal attenuation and its tolerance for

- interface port loss;
- through loss;
- isolation,

as defined in Figure 9, shall be published.

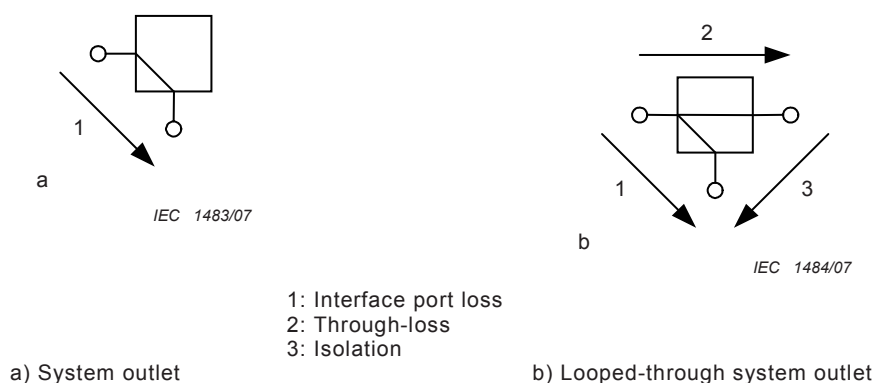

**Figure 9 – Types of losses of system outlets**

NOTE The looped-through system outlet shall provide enough isolation from the output to each interface port to meet at least the system requirements of IEC 60728-1 (mutual isolation between system outlets).

#### 5.3.4.5 Amplitude frequency response flatness

The flatness of the amplitude frequency response from the input port to all other ports shall be published.

Peak-to-peak narrowband flatness to the output port/s (looped-through only) shall be within 0,2 dB in a band of 0,5 MHz and 0,5 dB in a band of 7 MHz.

#### 5.3.4.6 Isolation between interface ports

All system outlets shall meet the following requirements.

The minimum attenuation between TV and radio interface ports shall be 10 dB over the operating frequency range.

The minimum attenuation between broadband interface ports shall be 20 dB over the operating frequency range.

Where filters are incorporated in the system outlet, the selectivity shall be published.

#### 5.3.4.7 Group delay variation

Shall be published.

#### 5.3.4.8 Intermodulation in system outlets

On the basis of the test method described in 4.8, it is required that the manufacturer shall specify the maximum return path signal level [dB( $\mu$ V)] according to Table 3.

This requirement is valid before and after the test with overvoltages (see 5.1.6).

**Table 3 – Maximum return path signal level derived from maximum allowed intermodulation distortion level in the downstream frequency band**

Test frequency in MHz		Max. level in dB(μV)
Return path (upstream)	$f_1 = 60$ $f_2 = 65$	Shall be specified
Distribution (downstream)	$2f_1 = 120$	≤ 15
	$f_1 + f_2 = 125$	≤ 15
	$2f_2 = 130$	≤ 15

NOTE 1 These frequencies should be applied in the case where the return path frequency band is specified up to 65 MHz. For other return path frequency bands,  $f_2$  is the highest specified return path frequency and  $f_1 = f_2 - 5$  MHz.

NOTE 2 An intermodulation level of 15 dB(μV) gives a signal to spurious ratio of 45 dB in the case where the forward signal level is 60 dB(μV).

## 5.4 Performance requirements and recommendations for splitters and taps

### 5.4.1 Description

Splitters and taps are used in the coaxial cable network and the subscriber network. A splitter divides the signal power at the input port equally or unequally between two or more (output) ports. A tap contains, in addition to its input and output ports, one or more tap ports.

A subscriber tap provides the principal isolation between subscribers. There are three quality grades. The grade of the equipment shall be published.

Taps and splitters may incorporate an a.c. or a d.c. bypass.

### 5.4.2 Mechanical requirements for connectors

The type of cable connection used shall be published.

### 5.4.3 Electrical parameters and requirements

#### 5.4.3.1 Return loss

The minimum return loss for the specified grade shall be according to Table 4.

**Table 4 – Return loss of splitters and taps**

Frequency range	Requirement		
	Grade 1	Grade 2	Grade 3
5 MHz to 10 MHz	Shall be published	Shall be published	Shall be published
10 MHz to 47 MHz	≥22 dB	≥18 dB	≥14 dB
47 MHz to 950 MHz	≥(22 dB – 1,5 dB/octave)	≥(18 dB – 1,5 dB/octave)	≥(14 dB – 1,5 dB/octave) but ≥10 dB
950 MHz to 3 000 MHz	≥14 dB decreasing linearly to 10 dB	≥10 dB decreasing linearly to 6 dB	≥10 dB decreasing linearly to 6 dB

NOTE The specifications in Table 4 are not applicable for splitters and taps in Japan (see Clause B.4).

For subscriber taps of grade 1 and grade 2, the input return loss in the frequency range from 10 MHz to 950 MHz shall be at least 10 dB, decreasing linearly to 6 dB at 3 000 MHz, with the interface ports either open- or short-circuited.

**5.4.3.2 Frequency range**

The operating frequency range shall be published.

**5.4.3.3 Splitter loss**

The nominal attenuation between input port and output port/s, and its tolerance, shall be published.

**5.4.3.4 Tap loss**

The nominal attenuation between input port and tap port/s, and its tolerance, shall be published.

**5.4.3.5 Through-loss (taps only)**

The nominal attenuation between input port and output port, and its tolerance, shall be published.

**5.4.3.6 Amplitude frequency response flatness**

The flatness of amplitude frequency response from the input to output and tap ports shall be published.

Narrowband peak-to-peak flatness at the output port shall be within 0,2 dB in a band of 0,5 MHz and 0,5 dB in a band of 7 MHz.

**5.4.3.7 Group delay variation**

Shall be published.

**5.4.3.8 Hum modulation**

For equipment incorporating an a.c. bypass, the value of the hum modulation shall be published in dB at the worst case of powering current of the equipment.

**5.4.3.9 Isolation****5.4.3.9.1 Splitters**

The isolation between all (output) ports shall be according to Table 5.

**Table 5 – Isolation of splitters**

Frequency range	Requirement		
	Grade 1	Grade 2	Grade 3
5 MHz to 10 MHz	Shall be published	Shall be published	Shall be published
10 MHz to 47 MHz	≥22 dB	≥18 dB	≥14 dB
47 MHz to 950 MHz	≥(22 dB – 1,5 dB/octave)	≥(18 dB – 1,5 dB/octave)	≥(14 dB – 1,5 dB/octave) but ≥10 dB
950 MHz to 3 000 MHz	≥14 dB decreasing linearly to 10 dB	≥10 dB decreasing linearly to 6 dB	≥10 dB decreasing linearly to 6 dB
NOTE The specifications in Table 5 are not applicable for splitters in Japan (see Clause B.4).			

**5.4.3.9.2 Taps**

The manufacturer shall publish the figures for isolation (between output and tap(s), or between all taps).

NOTE Subscriber taps should provide enough isolation from the output to each tap port or between all taps within one equipment to meet at least the system requirements of IEC 60728-1.

**5.4.3.10 Intermodulation in splitters and taps**

The manufacturer shall specify the maximum return path signal. For the requirements, see 5.3.4.8

**5.5 Performance requirements and recommendations for all other passive equipment**

**5.5.1 Description**

These equipment include

- transfer points;
- power injectors;
- cable splices;
- galvanic isolators;
- terminating resistors;
- filters;
- equalizers.

The quality grade shall be published.

**5.5.2 Mechanical requirements for connectors**

The type of cable connection used shall be published.

**5.5.3 Electrical parameters and requirements**

**5.5.3.1 Return loss**

The minimum return loss for the specified grade shall be according to Table 6.

**Table 6 – Return loss for all other passive equipment**

Frequency range	Requirement		
	Grade 1	Grade 2	Grade 3
5 MHz to 10 MHz	Shall be published	Shall be published	Shall be published
10 MHz to 47 MHz	≥22 dB	≥18 dB	≥14 dB
47 MHz to 950 MHz	≥(22 dB – 1,5 dB/octave)	≥(18 dB – 1,5 dB/octave)	≥(14 dB – 1,5 dB/octave) but ≥10 dB
950 MHz to 3 000 MHz	14 dB decreasing linearly to 10 dB	10 dB decreasing linearly to 6 dB	10 dB decreasing linearly to 6 dB
NOTE The specifications in Table 6 are not applicable for other passive equipment in Japan (see Clause B.5).			

For filters, no specifications shall be met within the stop band.

#### **5.5.3.2 Frequency range**

The operating frequency range shall be published.

For equipment with integral filters, a relaxation of 3 dB in return loss and isolation is permissible in the pass-band edges.

The pass-band edge is defined to be 8 MHz above the lower and 8 MHz below the upper cut-off frequency for AM-TV and, respectively, 30 MHz for FM-TV, 4 MHz for FM radio and 2 MHz for return path.

#### **5.5.3.3 Insertion loss**

The insertion loss and its tolerances shall be published.

#### **5.5.3.4 Amplitude frequency response flatness**

The flatness of the amplitude frequency response between input and output ports shall be published.

Narrowband peak-to-peak flatness shall be within 0,2 dB in a band of 0,5 MHz and 0,5 dB in a band of 7 MHz.

If the equipment incorporates a filter, the selectivity shall be published.

#### **5.5.3.5 Group delay variation**

The group delay variation in the specified frequency range shall be published.

#### **5.5.3.6 Hum modulation**

For equipment incorporating an a.c. bypass the value of the hum modulation shall be published in dB at the maximum specified powering current of the equipment.

### Annex A (informative)

#### Measurement errors which occur due to mismatched equipment

The matching condition when the error introduced by the mismatch of the equipment facing the EUT and that of the equipment under test (EUT) is acceptable. Examples of maximum errors of measurement results are given in Figure A.1 and Figure A.2.

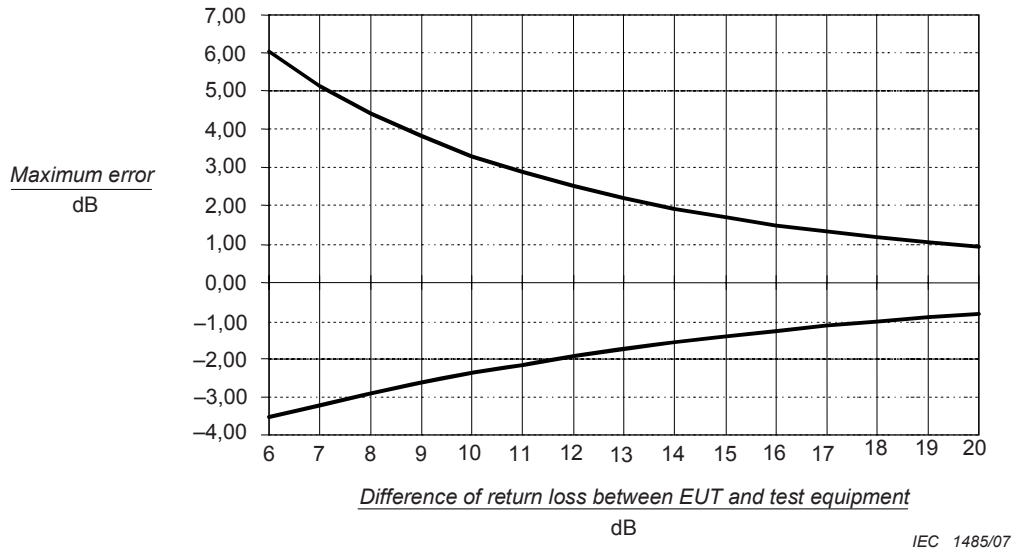

Figure A.1 – Error concerning return loss measurement

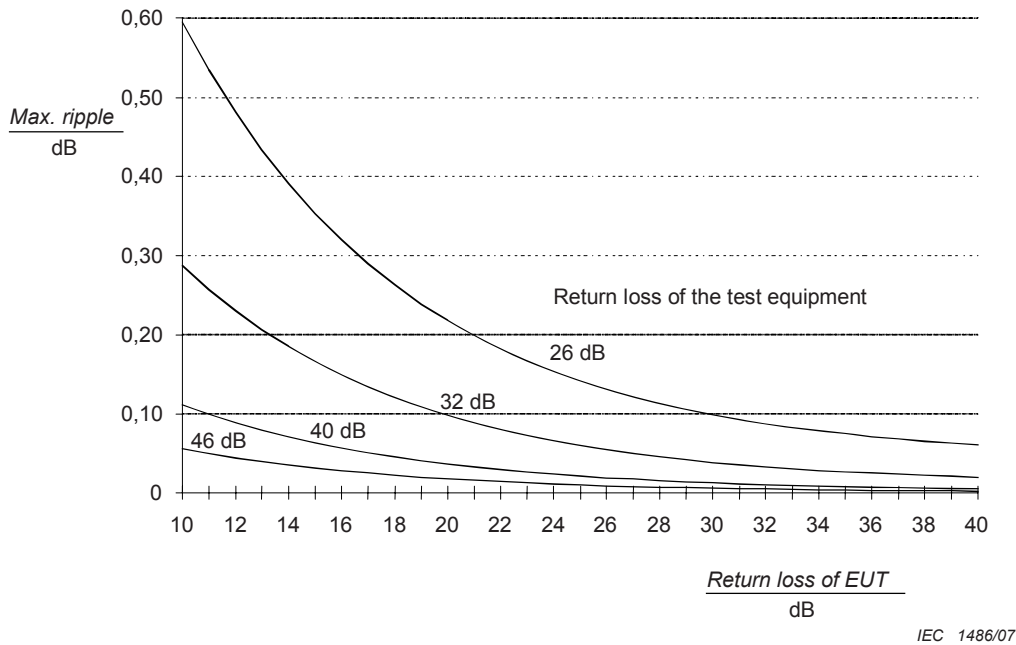

Figure A.2 – Maximum ripple

The return loss of test equipment should be at least 10 dB better than the expected EUT value.

## **Annex B** (informative)

### **Differences in some countries**

#### **B.1 Subclause 5.1.3, Finland**

In Finland, all equipment installed in locations that are not temperature controlled should meet their requirements within the temperature range -40 °C to +55 °C.

#### **B.2 Subclause 5.3, Table 2, Netherlands**

(Dutch Technical Regulations for CATV networks (Technische Voorschriften voor Centrale Antenne Inrichtingen, 3e uitgave), 21 December 1977, which are valid for CATV networks in accordance with Article 21 of the Dutch Telecommunications law (Stb. 1988, 520)).

The use of looped system outlets is not allowed.

#### **B.3 Subclause 5.3, Table 1 and Table 2, Japan**

The specifications in Table 1 and 2 are under consideration for the system outlet in Japan.

#### **B.4 Subclause 5.4, Table 4 and Table 5, Japan**

The specifications in Table 4 and 5 are under consideration for splitters and taps in Japan.

#### **B.5 Subclause 5.5, Table 6, Japan**

The specifications in Table 6 are under consideration for other passive equipment in Japan.



### **Bibliography**

IEC 60050-581, *International Electrotechnical Vocabulary – Chapter 581: Electromechanical components for electronic equipment*

IEC 60050-723, *International Electrotechnical Vocabulary – Chapter 723: Broadcasting: Sound, television, data*

---

## Annex ZA (normative)

### Normative references to international publications with their corresponding European publications

The following referenced documents are indispensable for the application of this document. For dated references, only the edition cited applies. For undated references, the latest edition of the referenced document (including any amendments) applies.

NOTE 1 When an international publication has been modified by common modifications, indicated by (mod), the relevant EN/HD applies.

NOTE 2 Where a standard cited below belongs to the EN 50000 series, the European Standard applies instead of the relevant International Standard.

<u>Publication</u>	<u>Year</u>	<u>Title</u>	<u>EN/HD</u>	<u>Year</u>
IEC 60068	Series	Environmental testing	EN 60068	Series
IEC 60417	Data-base	Graphical symbols for use on equipment	-	-
IEC 60529	- <sup>1)</sup>	Degrees of protection provided by enclosures (IP Code)	EN 60529 + corr. May	1991 <sup>2)</sup> 1993
IEC 60617	Data-base	Graphical symbols for diagrams	-	-
IEC 60728	Series	Cable networks for television signals, sound signals and interactive services	EN 60728 EN 50083	Series Series
IEC 60966-1	- <sup>1)</sup>	Radio frequency and coaxial cable assemblies - Part 1: Generic specification - General requirements and test methods	EN 60966-1	1999 <sup>2)</sup>
IEC 60966-2-4	- <sup>1)</sup>	Radio frequency and coaxial cables assemblies - Part 2-4: Detail specification for cable assemblies for radio and TV receivers - Frequency range 0 to 3 000 MHz, IEC 61169-2 connectors	EN 60966-2-4	2003 <sup>2)</sup>
IEC 60966-2-5	- <sup>1)</sup>	Radio frequency and coaxial cable assemblies - Part 2-5: Detail specification for cable assemblies for radio and TV receivers - Frequency range 0 to 1 000 MHz, IEC 61169-2 connectors	EN 60966-2-5	2003 <sup>2)</sup>
IEC 60966-2-6	- <sup>1)</sup>	Radio frequency and coaxial cable assemblies - Part 2-6: Detail specification for cable assemblies for radio and TV receivers - Frequency range 0 to 3 000 MHz, IEC 61169-24 connectors	EN 60966-2-6	2003 <sup>2)</sup>
IEC 61000-4-5	- <sup>1)</sup>	Electromagnetic compatibility (EMC) - Part 4-5: Testing and measurement techniques - Surge immunity test	EN 61000-4-5	2006 <sup>2)</sup>

<sup>1)</sup> Undated reference.

<sup>2)</sup> Valid edition at date of issue.

<u>Publication</u>	<u>Year</u>	<u>Title</u>	<u>EN/HD</u>	<u>Year</u>
IEC 61000-6-1	- <sup>1)</sup>	Electromagnetic compatibility (EMC) - Part 6-1: Generic standards - Immunity for residential, commercial and light-industrial environments	EN 61000-6-1	2007 <sup>2)</sup>
IEC 61169-1	- <sup>1)</sup>	Radio-frequency connectors - Part 1: Generic specification - General requirements and measuring methods	EN 61169-1	1994 <sup>2)</sup>
IEC 61169-2	- <sup>1)</sup>	Radio-frequency connectors - Part 2: Sectional specification - Radio frequency coaxial connectors of type 9,52	EN 61169-2	2007 <sup>2)</sup>
IEC 61169-24	- <sup>1)</sup>	Radio-frequency connectors - Part 24: Sectional specification - Radio frequency coaxial connectors with screw coupling, typically for use in 75 ohm cable distribution systems (type F)	EN 61169-24	2001 <sup>2)</sup>

**Annex ZB**  
(normative)**Special national conditions**

**Special national condition:** National characteristic or practice that cannot be changed even over a long period, e.g. climatic conditions, electrical earthing conditions.

NOTE If it affects harmonization, it forms part of the European Standard / Harmonization Document.

For the countries in which the relevant special national conditions apply these provisions are normative, for other countries they are informative.

<u>Clause</u>	<u>Special national condition</u>
---------------	-----------------------------------

<b>5.1.3</b>	<b>Finland</b>
--------------	----------------

All equipment installed in locations that are not temperature controlled shall meet their requirements within the temperature range -40 °C to +55 °C.

---

**Annex ZC**  
(informative)

**A-deviations**

**A-deviation:** National deviation due to regulations, the alteration of which is for the time being outside the competence of the CENELEC national member.

This European Standard does not fall under any Directive of the EC.

In the relevant CENELEC countries these A-deviations are valid instead of the provisions of the European Standard until they have been removed.

Clause      Deviation

**5.3**      **Netherlands**

**Table 2** (Dutch Technical Regulations for CATV networks (Technische Voorschriften voor Centrale Antenne Inrichtingen, 3e uitgave), 21 December 1977, which are valid for CATV networks in accordance with Article 21 of the Dutch Telecommunications law (Stb. 1988, 520)).

The use of looped system outlets is not allowed.

---

---

---

## British Standards Institute (BSI)

BSI is the independent national body responsible for preparing British Standards. It presents the UK view on standards in Europe and at the international level. It is incorporated by Royal Charter.

### Revisions

British Standards are updated by amendment or revision. Users of British Standards should make sure that they possess the latest amendments or editions.

It is the constant aim of BSI to improve the quality of our products and services. We would be grateful if anyone finding an inaccuracy or ambiguity while using this British Standard would inform the Secretary of the technical committee responsible, the identity of which can be found on the inside front cover.  
Tel: +44 (0)20 8996 9000 Fax: +44 (0)20 8996 7400

BSI offers members an individual updating service called PLUS which ensures that subscribers automatically receive the latest editions of standards.

### Buying standards

Orders for all BSI, international and foreign standards publications should be addressed to Customer Services.

Tel: +44 (0)20 8996 9001 Fax: +44 (0)20 8996 7001

Email: [orders@bsigroup.com](mailto:orders@bsigroup.com)

You may also buy directly using a debit/credit card from the BSI Shop on the Website <http://www.bsigroup.com/shop>.

In response to orders for international standards, it is BSI policy to supply the BSI implementation of those that have been published as British Standards, unless otherwise requested.

### Information on standards

BSI provides a wide range of information on national, European and international standards through its Library and its Technical Help to Exporters Service. Various BSI electronic information services are also available which give details on all its products and services. Contact the Information Centre.

Tel: +44 (0)20 8996 7111 Fax: +44 (0)20 8996 7048

Email: [info@bsigroup.com](mailto:info@bsigroup.com)

Subscribing members of BSI are kept up to date with standards developments and receive substantial discounts on the purchase price of standards. For details of these and other benefits contact Membership Administration.

Tel: +44 (0)20 8996 7002 Fax: +44 (0)20 8996 7001

Email: [membership@bsigroup.com](mailto:membership@bsigroup.com)

Information regarding online access to British Standards via British Standards Online can be found at <http://www.bsigroup.com/BSOL>.

Further information about BSI is available on the BSI website at <http://www.bsigroup.com>.

### Copyright

Copyright subsists in all BSI publications. BSI also holds the copyright, in the UK, of the publications of the international standardization bodies. Except as permitted under the Copyright, Designs and Patents Act 1988 no extract may be reproduced, stored in a retrieval system or transmitted in any form or by any means – electronic, photocopying, recording or otherwise – without prior written permission from BSI.

This does not preclude the free use, in the course of implementing the standard, of necessary details such as symbols, and size, type or grade designations. If these details are to be used for any other purpose than implementation then the prior written permission of BSI must be obtained.

Details and advice can be obtained from the Copyright & Licensing Manager.

Tel: +44 (0)20 8996 7070 Email: [copyright@bsigroup.com](mailto:copyright@bsigroup.com)