

Low-voltage switchgear and controlgear assemblies —

Part 1: Type-tested and partially type-tested assemblies

The European Standard EN 60439-1:1999, with the incorporation of amendment A1:2004, has the status of a British Standard

ICS 29.130.20

National foreword

This British Standard is the official English language version of EN 60439-1:1999, including amendment A1:2004. It is identical with IEC 60439-1:1999, including amendment 1:2004. It supersedes BS EN 60439-1:1994 which is withdrawn.

The UK participation in its preparation was entrusted by Technical Committee PEL/17, Switchgear, controlgear and HV-LV co-ordination, to Subcommittee PEL/17/3, Low-voltage switchgear and controlgear assemblies, which has the responsibility to:

- aid enquirers to understand the text;
- present to the responsible international/European committee any enquiries on the interpretation, or proposals for change, and keep the UK interests informed;
- monitor related international and European developments and promulgate them in the UK.

A list of organizations represented on this subcommittee can be obtained on request to its secretary.

Cross-references

The British Standards which implement international or European publications referred to in this document may be found in the *BSI Catalogue* under the section entitled “International Standards Correspondence Index”, or by using the “Search” facility of the *BSI Electronic Catalogue* or of British Standards Online.

A National annex NA is included. This gives additional information regarding the internal separation of ASSEMBLIES relevant to different types of construction, based on typical practice in the United Kingdom.

This publication does not purport to include all the necessary provisions of a contract. Users are responsible for its correct application.

Compliance with a British Standard does not of itself confer immunity from legal obligations.

This British Standard, having been prepared under the direction of the Electrotechnical Sector Committee, was published under the authority of the Standards Committee and comes into effect on 15 December 1999

© BSI 30 June 2004

Summary of pages

This document comprises a front cover, an inside front cover, the EN title page, pages 2 to 106, an inside back cover and a back cover.

The BSI copyright notice displayed in this document indicates when the document was last issued.

Sideline in this document indicates the most recent changes by amendment.

Amendments issued since publication

Amd. No.	Date	Comments
15206	30 June 2004	Indicated by a sideline

ISBN 0 580 35150 5

English version

Low-voltage switchgear and controlgear assemblies — Part 1: Type-tested and partially type-tested assemblies

(includes amendment A1:2004)

(IEC 60439-1:1999 + A1:2004)

Ensembles d'appareillage à basse tension —
Partie 1: Ensembles de série et ensembles
dérivés de série
(inclut l'amendement A1:2004)
(CEI 60439-1:1999 + A1:2004)

Niederspannung-
Schaltgerätekombinationen —
Teil 1: Typgeprüfte und partiell typgeprüfte
Kombinationen
(enthält Änderung A1:2004)
(IEC 60439-1:1999 + A1:2004)

This European Standard was approved by CENELEC on 1999-08-01; amendment A1 was approved by CENELEC on 2004-03-16. CENELEC members are bound to comply with the CEN/CENELEC Internal Regulations which stipulate the conditions for giving this European Standard the status of a national standard without any alteration.

Up-to-date lists and bibliographical references concerning such national standards may be obtained on application to the Central Secretariat or to any CENELEC member.

This European Standard exists in three official versions (English, French, German). A version in any other language made by translation under the responsibility of a CENELEC member into its own language and notified to the Central Secretariat has the same status as the official versions.

CENELEC members are the national electrotechnical committees of Austria, Belgium, Cyprus, Czech Republic, Denmark, Estonia, Finland, France, Germany, Greece, Hungary, Iceland, Ireland, Italy, Latvia, Lithuania, Luxembourg, Malta, Netherlands, Norway, Portugal, Slovakia, Slovenia, Spain, Sweden, Switzerland and United Kingdom.

CENELEC

European Committee for Electrotechnical Standardization
Comité Européen de Normalisation Electrotechnique
Europäisches Komitee für Elektrotechnische Normung

Central Secretariat: rue de Stassart 35, B-1050 Brussels

Foreword

The text of document 17D/214A/FDIS, future amendment to IEC 60439-1:1992, prepared by SC 17D, Low-voltage switchgear and controlgear assemblies, of IEC TC 17, Switchgear and controlgear, was submitted to the IEC-CENELEC parallel vote and was approved by CENELEC as amendment A3 to EN 60439-1:1994 on 1999-08-01.

The text of this document, together with that of IEC 60439-1:1992 and its amendments 1:1995 and 2:1996, was published by IEC as the fourth edition of IEC 60439-1 in September 1999. According to a decision of principle taken by the Technical Board of CENELEC, the approval of EN 60439-1:1994/A3 has been converted into the approval of a new EN 60439-1.

This European Standard supersedes EN 60439-1:1994 + A1:1995 + A11:1996 + A2:1997.

The following dates were fixed:

- latest date by which the EN has to be implemented at national level by publication of an identical national standard or by endorsement (dop) 2000-07-01
- latest date by which the national standards conflicting with the EN have to be withdrawn (dow) 2002-08-01

Annexes designated “normative” are part of the body of the standard.

Annexes designated “informative” are given for information only.

In this standard, Annex A, Annex B, Annex F, Annex G and Annex ZA are normative and Annex C, Annex D and Annex E are informative.

Annex ZA has been added by CENELEC.

Endorsement notice

The text of the International Standard IEC 60439-1:1999 was approved by CENELEC as a European Standard without any modification.

In the official version, for Bibliography, the following note has to be added for the standard indicated:

IEC 60364-5-537 NOTE: Harmonized, together with its amendment 1:1989, as HD 384.5.537 S2:1998 (modified).

Foreword to amendment A1

The text of document 17D/294/FDIS, future amendment 1 to IEC 60439-1:1999, prepared by SC 17D, Low-voltage switchgear and controlgear assemblies, of IEC TC 17, Switchgear and controlgear, was submitted to the IEC-CENELEC parallel vote and was approved by CENELEC as amendment A1 to EN 60439-1:1999 on 2004-03-16.

The following dates were fixed:

- latest date by which the amendment has to be implemented at national level by publication of an identical national standard or by endorsement (dop) 2005-01-01
- latest date by which the national standards conflicting with the amendment have to be withdrawn (dow) 2007-04-01

Annex ZA has been added by CENELEC.

Endorsement notice

The text of amendment 1:2004 to the International Standard IEC 60439-1:1999 was approved by CENELEC as an amendment to the European Standard without any modification.

CONTENTS

1	General	6
1.1	Scope and object.....	6
1.2	Normative references	6
2	Definitions	10
2.1	General	10
2.2	Constructional units of ASSEMBLIES	12
2.3	External design of ASSEMBLIES	13
2.4	Structural parts of ASSEMBLIES	14
2.5	Conditions of installation of ASSEMBLIES	16
2.6	Protective measures with regard to electric shock	16
2.7	Gangways within ASSEMBLIES.....	17
2.8	Electronic functions	18
2.9	Insulation co-ordination	18
2.10	Short-circuit currents	20
3	Classification of ASSEMBLIES	21
4	Electrical characteristics of ASSEMBLIES	21
4.1	Rated voltages	21
4.2	Rated current (I_n) (of a circuit of an ASSEMBLY)	22
4.3	Rated short-time withstand current (I_{cw}) (of a circuit of an ASSEMBLY)	22
4.4	Rated peak withstand current (I_{pk}) (of a circuit of an ASSEMBLY)	22
4.5	Rated conditional short-circuit current (I_{cc}) (of a circuit of an ASSEMBLY).....	22
4.6	Rated fused short-circuit current (I_{cf}) (of a circuit of an ASSEMBLY).....	23
4.7	Rated diversity factor	23
4.8	Rated frequency	23
5	Information to be given regarding the ASSEMBLY	23
5.1	Nameplates	23
5.2	Markings	24
5.3	Instructions for installation, operation and maintenance	24
6	Service conditions	25
6.1	Normal service conditions	25
6.2	Special service conditions	27
6.3	Conditions during transport, storage and erection.....	28
7	Design and construction	28
7.1	Mechanical design.....	28
7.2	Enclosure and degree of protection	32
7.3	Temperature rise	33
7.4	Protection against electric shock	35
7.5	Short-circuit protection and short-circuit withstand strength	43
7.6	Switching devices and components installed in ASSEMBLIES	47
7.7	Internal separation of ASSEMBLIES by barriers or partitions	52

7.8	Electrical connections inside an ASSEMBLY: bars and insulated conductors	53
7.9	Requirements for electronic equipment supply circuits	54
7.10	Electromagnetic compatibility (EMC)	56
7.11	Description of the types of electrical connections of functional units	58
8	Test specifications	59
8.1	Classification of tests	59
8.2	Type tests	60
8.3	Routine tests	76
Annex A (normative) Minimum and maximum cross-sections of copper conductors suitable for connection		
		81
Annex B (normative) Method of calculating the cross-sectional area of protective conductors with regard to thermal stresses due to currents of short duration		
		82
Annex C (<i>deleted</i>)		
		83
Annex D (informative) Forms of internal separations		
		84
Annex E (informative) Items subject to agreement between manufacturer and user		
		87
Annex F (normative) Measurement of creepage distances and clearances		
		88
Annex G (normative) Correlation between the nominal voltage of the supply system and the rated impulse withstand voltage of the equipment		
		93
Annex H (normative) Electromagnetic compatibility (EMC)		
		95
Annex ZA (normative) Normative references to international publications with their corresponding European publications		
		102
Bibliography		
		101
Figure 1 – Ratio $\frac{\hat{U}_i + \Delta u}{\hat{U}_i}$ as a function of time		
		55
Figure 2 – Maximum permitted harmonic component of the nominal system voltage		
		56
Figure D.1 – Symbols used in figures D.2		
		84
Figure D.2 – Forms 1 and 2		
		85
Figure D.2 – Forms 3 and 4		
		86
Figure F.1 – Measurement of ribs		
		88
Figure H.1 — Examples of ports		
		95
Table 1 – Values of rated diversity factor		
		23
Table 2 – Temperature-rise limits		
		34
Table 3 – Cross-sectional area of protective conductors (PE, PEN)		
		39
Table 3A – Cross-sectional area of a copper bonding conductor		
		40
Table 4 – Standard values for the factor n		
		45
Table 5 – Conductor selection and installation requirements		
		46
Table 6 – Electrical conditions for the different positions of withdrawable parts		
		51
Table 6A – Forms of internal separation		
		53
Table 7 – List of verifications and tests to be performed on TTA and PTTA		
		61

Table 8 – Test copper conductors for rated currents up to 400 A inclusive	63
Table 9 – Standard cross-sections of copper conductors corresponding to the rated current	64
Table 10	67
Table 11	67
Table 12 – Relationship between prospective fault current and diameter of copper wire	70
Table 13 – Dielectric withstand voltages for impulse, power frequency and d.c. tests.....	78
Table 14 – Minimum clearances in air	78
Table 15 – Test voltages across the open contacts of equipment suitable for isolation.....	79
Table 16 – Minimum creepage distances	80
Table A.1	81
Table B.1 – Values of <i>k</i> for insulated protective conductors not incorporated in cables, or bare protective conductors in contact with cable covering	82
Table G.1 – Correspondence between the nominal voltage of the supply system and the equipment rated impulse withstand voltage, in the case of overvoltage protection by surge-arresters according to IEC 60099-1.....	94
Table H.1 – Emission limits for Environment A	97
Table H.2 – Emission limits for Environment B	97
Table H.3 – Tests for EMC immunity for Environment A	98
Table H.4 – Tests for EMC immunity for Environment B	99
Table H.5 – Acceptance criteria when electromagnetic disturbances are present	100

LOW-VOLTAGE SWITCHGEAR AND CONTROLGEAR ASSEMBLIES –

Part 1: Type-tested and partially type-tested assemblies

1 General

1.1 Scope and object

This International Standard applies to low-voltage switchgear and controlgear ASSEMBLIES (type-tested ASSEMBLIES (TTA) and partially type-tested ASSEMBLIES (PTTA)), the rated voltage of which does not exceed 1 000 V a.c. at frequencies not exceeding 1 000 Hz, or 1 500 V d.c.

This standard also applies to ASSEMBLIES incorporating control and/or power equipment, the frequencies of which are higher. In this case, appropriate additional requirements will apply.

This standard applies to stationary or movable ASSEMBLIES with or without enclosure.

NOTE Additional requirements for certain specific types of assemblies are given in supplementary IEC standards.

This standard applies to ASSEMBLIES intended for use in connection with the generation, transmission, distribution and conversion of electric energy, and for the control of electric energy consuming equipment.

It also applies to ASSEMBLIES designed for use under special service conditions, for example in ships, in rail vehicles, for hoisting equipment or in explosive atmospheres, and for domestic (operated by unskilled persons) applications, provided that the relevant specific requirements are complied with.

This standard applies also to ASSEMBLIES designed for electrical equipment of machines. However, where applicable the additional requirements of IEC 60204-1 have to be fulfilled.

This standard does not apply to individual devices and self-contained components, such as motor starters, fuse switches, electronic equipment, etc. complying with their relevant standards.

The object of this standard is to lay down the definitions and to state the service conditions, construction requirements, technical characteristics and tests for low-voltage switchgear and controlgear ASSEMBLIES.

1.2 Normative references

The following referenced documents are indispensable for the application of this document. For dated references, only the edition cited applies. For undated references, the latest edition of the referenced document (including any amendments) applies.

IEC 60038:1983, *IEC standard voltages*

IEC 60050(441):1984, *International Electrotechnical Vocabulary (IEV) – Chapter 441: Switchgear, controlgear and fuses*

IEC 60050(471):1984, *International Electrotechnical Vocabulary (IEV) – Chapter 471: Insulators*

IEC 60050(604):1987, *International Electrotechnical Vocabulary (IEV) – Chapter 604: Generation, transmission and distribution of electricity – Operation*

IEC 60060, *High-voltage test techniques*

IEC 60071-1:1976, *Insulation co-ordination – Part 1: Terms, definitions, principles and rules*

IEC 60073:1996, *Basic and safety principles for man-machine interface, marking and identification – Coding principles for indication devices and actuators*

IEC 60099-1:1991, *Surge arresters – Part 1: Non-linear resistor type gapped surge arresters for a.c. systems*

IEC 60112:1979, *Method for determining the comparative and the proof-tracking indices of solid insulating materials under moist conditions*

IEC 60146-2:1974, *Semiconductor convertors – Part 2: Semiconductor self-commutated convertors*

IEC 60158-2:1982, *Low-voltage controlgear – Part 2: Semiconductor contactors (solid state contactors)*

IEC 60204-1:1997, *Safety of machinery – Electrical equipment of machines – Part 1: General requirements*

IEC 60227-3:1993, *Polyvinyl chloride insulated cables of rated voltages up to and including 450/750 V – Part 3: Non-sheathed cables for fixed wiring*

IEC 60227-4:1992, *Polyvinyl chloride insulated cables of rated voltages up to and including 450/750 V – Part 4: Sheathed cables for fixed wiring*

IEC 60245-3:1994, *Rubber insulated cables of rated voltages up to and including 450/750 V – Part 3: Heat resistant silicone insulated cables*

IEC 60245-4:1994, *Rubber insulated cables of rated voltages up to and including 450/750 V – Part 4: Cords and flexible cables*

IEC 60269, *Low-voltage fuses*

IEC 60364-3:1993, *Electrical installations of buildings – Part 3: Assessment of general characteristics*

IEC 60364-4-41:1992, *Electrical installations of buildings – Part 4: Protection for safety – Chapter 41: Protection against electric shock*

IEC 60364-4-443:1995, *Electrical installations of buildings – Part 4: Protection for safety – Chapter 44: Protection against overvoltages – Section 443: Protection against overvoltages of atmospheric origin or due to switching* *

IEC 60364-4-46:1981, *Electrical installations of buildings – Part 4: Protection for safety – Chapter 46: Isolation and switches*

IEC 60364-5-54:1980, *Electrical installations of buildings – Part 5: Selection and erection of electrical equipment – Chapter 54: Earthing arrangements and protective conductors*

IEC 60417 (all parts), *Graphical symbols for use on equipment. Index, survey and compilation of the single sheets*

IEC 60445:1988, *Identification of equipment terminals and of terminations of certain designated conductors, including general rules for an alphanumeric system*

IEC 60446:1989, *Identification of conductors by colours or numerals*

IEC 60447:1993, *Man-machine interface (MMI) – Actuating principles*

IEC 60502:1994, *Extruded solid dielectric insulated power cables for rated voltages from 1 kV to 30 kV*

IEC 60529:1989, *Degrees of protection provided by enclosures (IP Code)*

IEC 60664-1:1992, *Insulation coordination for equipment within low-voltage systems – Part 1: Principles, requirements and tests*

IEC 60695-2-10:2000, *Fire hazard testing - Part 2-10: Glowing/hot-wire based test methods – Glow-wire apparatus and common test procedure*

IEC 60695-2-11:2000, *Fire hazard testing - Part 2-11: Glowing/hot-wire based test methods – Glow-wire flammability test method for end-products*

IEC 60865 (all parts), *Short-circuit currents – Calculation of effects*

IEC 60890:1987, *A method of temperature-rise assessment by extrapolation for partially type-tested assemblies (PTTA) of low-voltage switchgear and controlgear*

IEC 60947-1:1988, *Low-voltage switchgear and controlgear – Part 1: General rules*

IEC 60947-3:1999, *Low-voltage switchgear and controlgear – Part 3: Switches, disconnectors, switch-disconnectors and fuse-combination units*

IEC 60947-4-1:1990, *Low-voltage switchgear and controlgear – Part 4: Contactors and motor-starters – Section 1: Electromechanical contactors and motor-starters*

* There is a consolidated edition 2.1 (1999) that includes IEC 60364-4-443 (1995) and its amendment 1 (1998).

IEC 61000-3-2:2000, *Electromagnetic compatibility (EMC) – Part 3-2: Limits – Limits for harmonic current emissions (equipment input current ≤ 16 A per phase)*

IEC 61000-4-2:1995, *Electromagnetic compatibility (EMC) – Part 4: Testing and measurement techniques – Section 2: Electrostatic discharge immunity test – Basic EMC Publication*

IEC 61000-4-3:2002, *Electromagnetic compatibility (EMC) – Part 4-3: Testing and measurement techniques – Radiated, radio-frequency, electromagnetic field immunity test*

IEC 61000-4-4:1995, *Electromagnetic compatibility (EMC) – Part 4: Testing and measurement techniques – Section 4: Electrical fast transient burst immunity test – Basic EMC Publication*

IEC 61000-4-5:1995, *Electromagnetic compatibility (EMC) – Part 4: Testing and measurement techniques – Section 5: Surge immunity tests*

IEC 61000-4-6:2003, *Electromagnetic compatibility (EMC) – Part 4-6: Testing and measurement techniques – Immunity to conducted disturbances, induced by radio-frequency fields*

IEC 61000-4-8:1993, *Electromagnetic compatibility (EMC) – Part 4-8: Testing and measurement techniques – Power frequency magnetic field immunity test*

IEC 61000-4-11:1994, *Electromagnetic compatibility (EMC) – Part 4-11: Testing and measurement techniques – Voltage dips, short interruptions and voltage variation immunity tests*

IEC 61000-4-13:2002, *Electromagnetic compatibility (EMC) – Part 4-13: Testing and measurement techniques – Harmonics and interharmonics including mains signalling at a.c. power port, low-frequency immunity tests*

IEC 61000-6-3:1996, *Electromagnetic compatibility (EMC) – Part 6-3: Generic standards – Emission standard for residential, commercial and light-industrial environments*

IEC 61000-6-4:1997, *Electromagnetic compatibility (EMC) – Part 6-4: Generic standards – Emission standard for industrial environments*

IEC 61082 (all parts), *Preparation of documents used in electrotechnology*

IEC 61117:1992, *A method for assessing the short-circuit withstand strength of partially type-tested assemblies (PTTA)*

IEC 61346-1:1996, *Industrial systems, installation and equipment and industrial products – Structuring principles and reference designations – Part 1: Basic rules*

CISPR 11:1997, *Industrial, scientific and medical (ISM) radio-frequency equipment – Electromagnetic disturbance characteristics – Limits and methods of measurement Amendment 1 (1999)*

2 Definitions

For the purpose of this International Standard, the following definitions apply.

NOTE Certain definitions in this clause are taken unchanged or modified from those of IEC 60050 (IEV) or from other IEC publications.

2.1 General

2.1.1

low-voltage switchgear and controlgear assembly (ASSEMBLY)

a combination of one or more low-voltage switching devices together with associated control, measuring, signalling, protective, regulating equipment, etc., completely assembled under the responsibility of the manufacturer with all the internal electrical and mechanical inter-connections and structural parts (see 2.4)

NOTE 1 Throughout this standard, the abbreviation ASSEMBLY is used for a low-voltage switchgear and controlgear assembly.

NOTE 2 The components of the ASSEMBLY may be electromechanical or electronic.

NOTE 3 For various reasons, for example transport or production, certain steps of assembly may be made in a place outside the factory of the manufacturer.

2.1.1.1

type-tested low-voltage switchgear and controlgear assembly (TTA)

a low-voltage switchgear and controlgear ASSEMBLY conforming to an established type or system without deviations likely to significantly influence the performance, from the typical ASSEMBLY verified to be in accordance with this standard

NOTE 1 Throughout this standard, the abbreviation TTA is used for a type-tested low-voltage switchgear and controlgear assembly.

NOTE 2 For various reasons, for example transport or production, certain steps of assembly may take place outside the factory of the manufacturer of the TTA. Such an ASSEMBLY is considered as a TTA provided the assembly is performed in accordance with the manufacturer's instructions in such a manner that compliance of the established type or system with this standard is assured, including submission to applicable routine tests.

2.1.1.2

partially type-tested low-voltage switchgear and controlgear assembly (PTTA)

a low-voltage switchgear and controlgear ASSEMBLY, containing both type-tested and non-type-tested arrangements, provided that the latter are derived (e.g. by calculation) from type-tested arrangements which have complied with the relevant tests (see table 7).

NOTE Throughout this standard, the abbreviation PTTA is used for a partially type-tested switchgear and controlgear assembly.

2.1.2

main circuit (of an ASSEMBLY)

all the conductive parts of an ASSEMBLY included in a circuit which is intended to transmit electrical energy [IEV 441-13-02]

2.1.3

auxiliary circuit (of an ASSEMBLY)

all the conductive parts of an ASSEMBLY included in a circuit (other than the main circuit) intended to control, measure, signal, regulate, process data, etc. [IEV 441-13-03 modified]

NOTE The auxiliary circuits of an ASSEMBLY include the control and the auxiliary circuits of the switching devices.

2.1.4

busbar

a low-impedance conductor to which several electric circuits can be separately connected

NOTE The term "busbar" does not presuppose the geometrical shape, size or dimensions of the conductor.

2.1.4.1

main busbar

a busbar to which one or several distribution busbars and/or incoming and outgoing units can be connected

2.1.4.2

distribution busbar

a busbar within one section which is connected to a main busbar and from which outgoing units are supplied

2.1.5

functional unit

a part of an ASSEMBLY comprising all the electrical and mechanical elements that contribute to the fulfilment of the same function

NOTE Conductors which are connected to a functional unit but which are external to its compartment or enclosed protected space (e.g. auxiliary cables connected to a common compartment) are not considered to form part of the functional unit.

2.1.6

incoming unit

a functional unit through which electrical energy is normally fed into the ASSEMBLY

2.1.7

outgoing unit

a functional unit through which electrical energy is normally supplied to one or more outgoing circuits

2.1.8

functional group

a group of several functional units which are electrically interconnected for the fulfilment of their operational functions

2.1.9

test situation

condition of an ASSEMBLY or part of it in which the relevant main circuits are open on its supply side but not necessarily isolated whilst the associated auxiliary circuits are connected, allowing tests of the operation of incorporated devices

2.1.10

isolated situation

condition of an ASSEMBLY or part of it in which the relevant main circuits are isolated on their supply side and the associated auxiliary circuits are also isolated

2.1.11

connected situation

a condition of an ASSEMBLY or part of it in which the relevant main circuit and associated auxiliary circuits are connected for their normally intended function

2.2 Constructional units of ASSEMBLIES

2.2.1 section

a constructional unit of an ASSEMBLY between two successive vertical delineations

2.2.2 sub-section

a constructional unit of an ASSEMBLY between two successive horizontal delineations within a section

2.2.3 compartment

a section or sub-section enclosed except for openings necessary for interconnection, control or ventilation

2.2.4 transport unit

a part of an ASSEMBLY or a complete ASSEMBLY suitable for shipping without being dismantled

2.2.5 fixed part

a part consisting of components assembled and wired on a common support and which is designed for fixed installation (see 7.6.3)

2.2.6 removable part

a part which may be removed entirely from the ASSEMBLY and replaced even though the circuit to which it is connected may be live

2.2.7 withdrawable part

removable part which can be moved from the connected position to the isolated position and to a test position, if any, whilst remaining mechanically attached to the ASSEMBLY

2.2.8 connected position

the position of a removable or withdrawable part when it is fully connected for its normally intended function

2.2.9 test position

a position of a withdrawable part in which the relevant main circuits are open on its supply side but not necessarily isolated and in which the auxiliary circuits are connected, allowing tests of the operation of the withdrawable part, that part remaining mechanically attached to the ASSEMBLY

NOTE The opening may also be achieved without any mechanical movement of the withdrawable part by operation of a suitable device.

2.2.10 isolated position

position of a withdrawable part in which an isolating distance (see 7.1.2.2) is established in main and auxiliary circuits on its supply side, the withdrawable part remaining mechanically attached to the ASSEMBLY

NOTE The isolating distance may also be established without any mechanical movement of the withdrawable part by operation of a suitable device.

2.2.11**removed position**

the position of a removable or withdrawable part when it is outside the ASSEMBLY, and mechanically and electrically separated from it

2.2.12**electrical connections of functional units****2.2.12.1****fixed connection**

a connection which is connected or disconnected by means of a tool

2.2.12.2**disconnectable connection**

a connection which is connected or disconnected by manual operation of the connecting means without a tool

2.2.12.3**withdrawable connection**

connection which is connected or disconnected by bringing the functional unit into the connected or isolated situation

2.3 External design of ASSEMBLIES**2.3.1****open-type ASSEMBLY**

an ASSEMBLY consisting of a supporting structure which supports the electrical equipment, the live parts of the electrical equipment being accessible

2.3.2**dead-front ASSEMBLY**

an open-type ASSEMBLY with a front covering which provides a degree of protection from the front. Live parts may be accessible from the other directions

2.3.3**enclosed ASSEMBLY**

an ASSEMBLY which is enclosed on all sides with the possible exception of its mounting surface in such a manner as to provide a degree of protection

2.3.3.1**cubicle-type ASSEMBLY**

an enclosed ASSEMBLY in principle of the floor-standing type which may comprise several sections, sub-sections or compartments

2.3.3.2**multi-cubicle-type ASSEMBLY**

a combination of a number of mechanically joined cubicles

2.3.3.3**desk-type ASSEMBLY**

an enclosed ASSEMBLY with a horizontal or inclined control panel or a combination of both, which incorporates control, measuring, signalling, etc., apparatus

2.3.3.4**box-type ASSEMBLY**

an enclosed ASSEMBLY, in principle intended to be mounted on a vertical plane

2.3.3.5

multi-box-type ASSEMBLY

a combination of boxes mechanically joined together, with or without a common supporting frame, the electrical connections passing between two adjacent boxes through openings in the adjoining faces

2.3.4

busbar trunking system (busway)

a type-tested ASSEMBLY in the form of a conductor system comprising busbars which are spaced and supported by insulating material in a duct, trough or similar enclosure [IEV 441-12-07 modified]

The ASSEMBLY may consist of units such as:

- busbar trunking units with or without tap-off facilities;
- phase transposition, expansion, flexible, feeder and adapter units;
- tap-off units.

NOTE The term "busbar" does not presuppose the geometrical shape, size and dimensions of the conductor.

2.4 Structural parts of ASSEMBLIES

2.4.1

supporting structure

a structure forming part of an ASSEMBLY designed to support various components of an ASSEMBLY and an enclosure, if any

2.4.2

mounting structure

a structure not forming part of an ASSEMBLY designed to support an enclosed ASSEMBLY

2.4.3

mounting plate*

a plate designed to support various components and suitable for installation in an ASSEMBLY

2.4.4

mounting frame*

a framework designed to support various components and suitable for installation in an ASSEMBLY

2.4.5

enclosure

housing affording the type and degree of protection suitable for the intended application

[IEV 195-02-35]

2.4.6

cover

a part of the external enclosure of an ASSEMBLY

* If these structural parts incorporate apparatus, they may constitute self-contained ASSEMBLIES.

2.4.7**door**

a hinged or sliding cover

2.4.8**removable cover**

a cover which is designed for closing an opening in the external enclosure and which can be removed for carrying out certain operations and maintenance work

2.4.9**cover plate**

a part of an ASSEMBLY – in general of a box (see 2.3.3.4) – which is used for closing an opening in the external enclosure and designed to be held in place by screws or similar means. It is not normally removed after the equipment is put into service

NOTE The cover plate can be provided with cable entries.

2.4.10**partition**

a part of the enclosure of a compartment separating it from other compartments

2.4.11**(electrically) protective barrier**

part providing protection against direct contact from any usual direction of access

[IEV 195-06-15]

2.4.12**(electrically) protective obstacle**

part preventing unintentional direct contact, but not preventing direct contact by deliberate action

[IEV 195-06-16]

2.4.13**shutter**

a part which can be moved:

- between a position in which it permits engagement of the contacts of removable or withdrawable parts with fixed contacts, and
- a position in which it becomes a part of a cover or a partition shielding the fixed contacts
[IEV 441-13-07 modified]

2.4.14**cable entry**

a part with openings which permit the passage of cables into the ASSEMBLY

NOTE A cable entry can at the same time be designed as a cable sealing end.

2.4.15**spare spaces****2.4.15.1****free space**

an empty space of a section

2.4.15.2**unequipped space**

a part of a section incorporating busbars only

2.4.15.3

partially equipped space

a part of a section fully equipped except for the functional units. The functional units which can be installed are defined in number of modules and size

2.4.15.4

fully equipped space

a part of a section fully equipped with functional units not assigned to a specific use

2.4.16

enclosed protected space

a part of an ASSEMBLY intended to enclose electrical components and which provides specified protection against external influences and contact with live parts

2.4.17

insertion interlock

a device preventing the introduction of a removable or withdrawable part into a location not intended for that removable or withdrawable part

2.5 Conditions of installation of ASSEMBLIES

2.5.1

ASSEMBLY for indoor installation

an ASSEMBLY which is designed for use in locations where the usual service conditions for indoor use as specified in 6.1 of this standard are fulfilled

2.5.2

ASSEMBLY for outdoor installation

an ASSEMBLY which is designed for use under the usual service conditions for outdoor use as specified in 6.1 of this standard

2.5.3

stationary ASSEMBLY

an ASSEMBLY which is designed to be fixed at its place of installation, for instance to the floor or to a wall, and to be used at this place

2.5.4

movable ASSEMBLY

an ASSEMBLY which is designed so that it can readily be moved from one place of use to another

2.6 Protective measures with regard to electric shock

2.6.1

live part

a conductor or conductive part intended to be energized in normal use, including a neutral conductor but, by convention, not a PEN conductor [IEV 826-03-01]

NOTE This term does not necessarily imply a risk of electric shock.

2.6.2

exposed conductive part

a conductive part of electrical equipment, which can be touched and which is not normally live, but which may become live under fault conditions [IEV 826-03-02 modified]

2.6.3**protective conductor**

(identification: PE)

conductor provided for purposes of safety, for example protection against electric shock

[IEV 195-02-09]

NOTE As an example, the protective conductor can electrically connect the following parts:

- exposed conductive parts;
- extraneous conductive parts;
- main earthing terminal;
- earth electrode;
- earthed point of the source or artificial neutral.

2.6.4**neutral conductor**

conductor electrically connected to the neutral point and capable of contributing to the distribution of electric energy

[IEV 195-02-06]

2.6.5**PEN conductor**

conductor combining the functions of both a protective earthing conductor and a neutral conductor

[IEV 195-02-12]

2.6.6**fault current**

a current resulting from an insulation failure or the bridging of insulation

2.6.7**earth fault current**

a fault current which flows to earth

2.6.8**protection against direct contact**

prevention of dangerous contact of persons with live parts

2.6.9**protection against indirect contact**

prevention of dangerous contact of persons with exposed conductive parts

2.7 Gangways within ASSEMBLIES**2.7.1****operating gangway within an ASSEMBLY**

a space which must be used by the operator for the proper operation and supervision of the ASSEMBLY

2.7.2**maintenance gangway within an ASSEMBLY**

a space which is accessible to authorized personnel only and primarily intended for use when servicing the installed equipment

2.8 Electronic functions

2.8.1

screening

protection of conductors or equipment against interference caused in particular by electromagnetic radiation from other conductors or equipment

2.9 Insulation co-ordination

2.9.1

clearance

the distance between two conductive parts along a string stretched the shortest way between these conductive parts [2.5.46 of IEC 60947-1] [IEV 441-17-31]

2.9.2

isolating distance (of a pole of a mechanical switching device)

the clearance between open contacts meeting the safety requirements specified for disconnectors [2.5.50 of IEC 60947-1] [IEV 441-17-35]

2.9.3

creepage distance

the shortest distance along the surface of an insulating material between two conductive parts [2.5.51 of IEC 60947-1] [IEV 471-01-08 modified]

NOTE A joint between two pieces of insulating material is considered part of the surface.

2.9.4

working voltage

the highest value of the a.c. (r.m.s.) or d.c. voltage which may occur (locally) across any insulation at rated supply voltage, transients being disregarded, in open circuit conditions or under normal operating conditions [2.5.52 of IEC 60947-1]

2.9.5

temporary overvoltage

the phase-to-earth, phase-to-neutral or phase-to-phase overvoltage at a given location and of relatively long duration (several seconds) [2.5.53 of IEC 60947-1] [IEV 604-03-12 modified]

2.9.6

transient overvoltages

the transient overvoltages in the sense of this standard are the following [2.5.54 of IEC 60947-1]

2.9.6.1

switching overvoltage

a transient overvoltage at a given location on a system due to a specific switching operation or fault [2.5.54.1 of IEC 60947-1] [IEV 604-03-29 modified]

2.9.6.2

lightning overvoltage

a transient overvoltage at a given location on a system due to a specific lightning discharge (see also IEC 60060 and IEC 60071-1) [2.5.54.2 of IEC 60947-1]

2.9.7**impulse withstand voltage**

the highest peak value of an impulse voltage, of prescribed form and polarity, which does not cause breakdown under specified conditions of test [2.5.55 of IEC 60947-1]

2.9.8**power-frequency withstand voltage**

the r.m.s. value of a power-frequency sinusoidal voltage which does not cause breakdown under specified conditions of test [2.5.56 of IEC 60947-1] [IEV 604-03-40 modified]

2.9.9**pollution**

any condition of foreign matter, solid, liquid or gaseous (ionized gases), that may affect dielectric strength or surface resistivity [2.5.57 of IEC 60947-1]

2.9.10**pollution degree (of environmental conditions)**

a conventional number based on the amount of conductive or hygroscopic dust, ionized gas or salt, and on the relative humidity and its frequency of occurrence resulting in hygroscopic absorption or condensation of moisture leading to reduction in dielectric strength and/or surface resistivity

NOTE 1 The pollution degree to which the insulating materials of devices and components are exposed may be different from that of the macro-environment where the devices or components are located because of protection offered by means such as an enclosure or internal heating to prevent absorption or condensation of moisture.

NOTE 2 For the purpose of this standard, the pollution degree is of the micro-environment. [2.5.59 of IEC 60947-1]

2.9.11**micro-environment (of a clearance or creepage distance)**

the ambient conditions which surround the clearance or creepage distance under consideration

NOTE The micro-environment of the creepage distance or clearance and not the environment of the ASSEMBLY or components determines the effect on the insulation. The micro-environment may be better or worse than the environment of the ASSEMBLY or components. It includes all factors influencing the insulation, such as climatic and electromagnetic conditions, generation of pollution, etc. [2.5.59 of IEC 60947-1 modified]

2.9.12**overvoltage category (of a circuit or within an electrical system)**

a conventional number based on limiting (or controlling) the values of prospective transient overvoltages occurring in a circuit (or within an electrical system having different nominal voltages) and depending upon the means employed to influence the overvoltages

NOTE In an electrical system, the transition from one overvoltage category to another of lower category is obtained through appropriate means complying with interface requirements, such as an overvoltage protective device or a series-shunt impedance arrangement capable of dissipating, absorbing, or diverting the energy in the associated surge current, to lower the transient overvoltage value to that of the desired lower overvoltage category. [2.5.60 of IEC 60947-1]

2.9.13**surge arrester**

a device designed to protect the electrical apparatus from high transient overvoltages and to limit the duration and frequently the amplitude of the follow-on current [2.2.22 of IEC 60947-1] [IEV 604-03-51]

2.9.14**co-ordination of insulation**

the correlation of insulating characteristics of electrical equipment with the expected overvoltages and the characteristics of overvoltage protective devices on the one hand, and with the expected micro-environment and the pollution protective means on the other hand [2.5.61 of IEC 60947-1] [IEV 604-03-08 modified]

2.9.15**homogeneous (uniform) field**

an electric field which has an essentially constant voltage gradient between electrodes, such as that between two spheres where the radius of each sphere is greater than the distance between them [2.5.62 of IEC 60947-1]

2.9.16**inhomogeneous (non-uniform) field**

an electric field which has not an essentially constant voltage gradient between electrodes [2.5.63 of IEC 60947-1]

2.9.17**tracking**

the progressive formation of conducting paths which are produced on the surface of a solid insulating material, due to the combined effects of electric stress and electrolytic contamination on this surface [2.5.64 of IEC 60947-1]

2.9.18**comparative tracking index (CTI)**

the numerical value of the maximum voltage in volts at which a material withstands 50 drops of a defined test liquid without tracking

NOTE The value of each test voltage and the CTI should be divisible by 25. [2.5.65 of IEC 60947-1]

2.10 Short-circuit currents**2.10.1****short-circuit current (I_c) (of a circuit of an ASSEMBLY)**

an over-current resulting from a short circuit due to a fault or an incorrect connection in an electric circuit [2.1.6 of IEC 60947-1] [IEV 441-11-07 modified]

2.10.2**prospective short-circuit current (I_{cp}) (of a circuit of an ASSEMBLY)**

a current which flows when the supply conductors to the circuit are short-circuited by a conductor of negligible impedance located as near as possible to the supply terminals of the ASSEMBLY

2.10.3**cut-off current; let-through current**

the maximum instantaneous value of current attained during the breaking operation of a switching device or a fuse [IEV 441-17-12]

NOTE This concept is of particular importance when the switching device or the fuse operates in such a manner that the prospective peak current of the circuit is not reached.

2.11**electromagnetic compatibility (EMC)**

NOTE For EMC related terms and definitions, see annex H.

3 Classification of ASSEMBLIES

ASSEMBLIES are classified according to:

- the external design (see 2.3);
- the place of installation (see 2.5.1 and 2.5.2);
- the conditions of installation with respect to mobility (see 2.5.3 and 2.5.4);
- the degree of protection (see 7.2.1);
- the type of enclosure;
- the method of mounting, for example fixed or removable parts (see 7.6.3 and 7.6.4);
- the measures for the protection of persons (see 7.4);
- the form of internal separation (see 7.7);
- the types of electrical connections of functional units (see 7.11).

4 Electrical characteristics of ASSEMBLIES

An ASSEMBLY is defined by the following electrical characteristics.

4.1 Rated voltages

An ASSEMBLY is defined by the following rated voltages of its various circuits.

4.1.1 Rated operational voltage (of a circuit of an ASSEMBLY)

The rated operational voltage (U_e) of a circuit of an ASSEMBLY is the value of voltage which, combined with the rated current of this circuit, determines its application.

For polyphase circuits, it is stated as the voltage between phases.

NOTE Standard values of rated control circuit voltages are found in the relevant standards for the incorporated devices.

The manufacturer of the ASSEMBLY shall state the limits of voltage necessary for correct functioning of the main and auxiliary circuits. In any case, these limits must be such that the voltage at the control circuit terminals of incorporated components is maintained under normal load conditions, within the limits specified in the relevant IEC standards.

4.1.2 Rated insulation voltage (U_i) (of a circuit of an ASSEMBLY)

The rated insulation voltage (U_i) of a circuit of an ASSEMBLY is the voltage value to which dielectric test voltages and creepage distances are referred.

The rated operational voltage of any circuit of the ASSEMBLY shall not exceed its rated insulation voltage. It is assumed that the working voltage of any circuit of an ASSEMBLY will not, even temporarily, exceed 110 % of its rated insulation voltage.

NOTE For single-phase circuits derived from IT systems (see IEC 60364-3), the rated insulation voltage should be at least equal to the voltage between phases of the supply.

For polyphase circuits, it is stated as the voltage between phases.

4.1.3 Rated impulse withstand voltage (U_{imp}) (of a circuit of an ASSEMBLY)

The peak value of an impulse voltage of prescribed form and polarity which the circuit of an ASSEMBLY is capable of withstanding without failure under specified conditions of test and to which the values of the clearances are referred.

The rated impulse withstand voltage of a circuit of an ASSEMBLY shall be equal to or higher than the values stated for the transient overvoltages occurring in the system in which the ASSEMBLY is inserted.

NOTE The preferred values of rated impulse withstand voltage are those given in table 13.

4.2 Rated current (I_n) (of a circuit of an ASSEMBLY)

The rated current of a circuit of an ASSEMBLY is stated by the manufacturer, taking into consideration the ratings of the components of the electrical equipment within the ASSEMBLY, their disposition and application. This current must be carried without the temperature-rise of the various parts of the ASSEMBLY exceeding the limits specified in 7.3 (table 2) when verified according to 8.2.1.

NOTE Due to the complex factors determining the rated currents, no standard values can be given.

4.3 Rated short-time withstand current (I_{cw}) (of a circuit of an ASSEMBLY)

The rated short-time withstand current of a circuit of an ASSEMBLY is the r.m.s. value of short-time current assigned to that circuit by the manufacturer which that circuit can carry without damage under the test conditions specified in 8.2.3. Unless otherwise stated by the manufacturer, the time is 1 s. [IEV 441-17-17 modified]

For a.c., the value of the current is the r.m.s. value of the a.c. component and it is assumed that the highest peak value likely to occur does not exceed n times this r.m.s. value, the factor n being given in 7.5.3.

NOTE 1 If the time is shorter than 1 s, both the rated short-time withstand current and the time should be stated, for example 20 kA, 0,2 s.

NOTE 2 The rated short-time withstand current can be either a prospective current when the tests are conducted at the rated operational voltage or an actual current when the tests are conducted at a lower voltage.

4.4 Rated peak withstand current (I_{pk}) (of a circuit of an ASSEMBLY)

The rated peak withstand current of a circuit of an ASSEMBLY is the value of peak current assigned to that circuit by the manufacturer which that circuit can withstand satisfactorily under the test conditions specified in 8.2.3 (see also 7.5.3). [IEV 441-17-18 modified]

4.5 Rated conditional short-circuit current (I_{cc}) (of a circuit of an ASSEMBLY)

The rated conditional short-circuit current of a circuit of an ASSEMBLY is the value of prospective short-circuit current, stated by the manufacturer, which that circuit, protected by a short-circuit protective device specified by the manufacturer, can withstand satisfactorily for the operating time of the device under the test conditions specified in 8.2.3 (see also 7.5.2).

The details of the specified short-circuit protective device shall be stated by the manufacturer.

NOTE 1 For a.c., the rated conditional short-circuit current is expressed by the r.m.s. value of the a.c. component.

NOTE 2 The short-circuit protective device may either form an integral part of the ASSEMBLY or be a separate unit.

4.6 Rated fused short-circuit current (I_{cf}) (of a circuit of an ASSEMBLY)

Void.

4.7 Rated diversity factor

The rated diversity factor of an ASSEMBLY or a part of an ASSEMBLY having several main circuits (e.g. a section or sub-section) is the ratio of the maximum sum, at any one time, of the assumed currents of all the main circuits involved to the sum of the rated currents of all the main circuits of the ASSEMBLY or the selected part of the ASSEMBLY.

When the manufacturer states a rated diversity factor, this factor shall be used for the temperature-rise test in accordance with 8.2.1.

NOTE In the absence of information concerning the actual currents, the following conventional values may be used.

Table 1 – Values of rated diversity factor

Number of main circuits	Rated diversity factor
2 and 3	0,9
4 and 5	0,8
6 to 9 inclusive	0,7
10 (and above)	0,6

4.8 Rated frequency

The rated frequency of an ASSEMBLY is the value of frequency which designates it and to which the operating conditions are referred.

If the circuits of an ASSEMBLY are designed for different values of frequency, the rated frequency of each circuit shall be given.

NOTE The frequency should be within the limits specified in the relevant IEC standards for the incorporated components. Unless otherwise stated by the manufacturer of the ASSEMBLY, the limits are assumed to be 98 % and 102 % of the rated frequency.

5 Information to be given regarding the ASSEMBLY

The following information shall be given by the manufacturer.

5.1 Nameplates

Each ASSEMBLY shall be provided with one or more plates, marked in a durable manner and located in a place such that they are visible and legible when the ASSEMBLY is installed.

Information specified under items a) and b) shall be given on the nameplate.

Information from items c) to t), where applicable, shall be given either on the nameplates or in the technical documentation of the manufacturer:

a) manufacturer's name or trade mark;

NOTE The manufacturer is deemed to be the organization taking the responsibility for the completed ASSEMBLY.

b) type designation or identification number, or any other means of identification making it possible to obtain relevant information from the manufacturer;

c) IEC 60439-1;

d) type of current (and frequency, in the case of a.c.);

e) rated operational voltages (see 4.1.1);

f) rated insulation voltages (see 4.1.2);

– rated impulse withstand voltage, when declared by the manufacturer (see 4.1.3);

g) rated voltages of auxiliary circuits (if applicable);

j) rated current of each main circuit (if applicable; see 4.2);

k) short-circuit withstand strength (see 7.5.2);

l) degree of protection (see 7.2.1);

m) measures for protection against electric shock (see 7.4);

n) service conditions for indoor use, outdoor use or special use, if different from the usual service conditions as given in 6.1;

– pollution degree, when declared by the manufacturer (see 6.1.2.3);

o) types of system earthing for which the ASSEMBLY is designed;

p) dimensions (see figures C.3 and C.4) given preferably in the order of height, width (or length), depth;

q) weight;

r) form of internal separation (see 7.7);

s) types of electrical connections of functional units (see 7.11);

t) environment A and/or B (see 7.10.1).

5.2 Markings

Inside the ASSEMBLY, it shall be possible to identify individual circuits and their protective devices.

Where items of equipment of the ASSEMBLY are designated, the designations used shall be identical with those in IEC 61346-1 and with those in the wiring diagrams which shall be in accordance with IEC 61082.

5.3 Instructions for installation, operation and maintenance

The manufacturer shall specify in his documents or catalogues the conditions, if any, for the installation, operation and maintenance of the ASSEMBLY and the equipment contained therein.

If necessary, the instructions for the transport, installation and operation of the ASSEMBLY shall indicate the measures that are of particular importance for the proper and correct installation, commissioning and operation of the ASSEMBLY.

Where necessary, the above-mentioned documents shall indicate the recommended extent and frequency of maintenance.

If the circuitry is not obvious from the physical arrangement of the apparatus installed, suitable information shall be supplied, for example wiring diagrams or tables.

The ASSEMBLY manufacturer shall specify the measures to be taken, if any, with regard to EMC associated with the installation, operation and maintenance of the ASSEMBLY.

If an ASSEMBLY specifically intended for environment A is to be used in environment B the following warning shall be included in the operating instructions:

Warning:

This is a product for environment A. In a domestic environment this product may cause radio interference in which case the user may be required to take adequate measures.

6 Service conditions

6.1 Normal service conditions

ASSEMBLIES conforming to this standard are intended for use under the following service conditions.

NOTE If components, for example relays, electronic equipment, are used which are not designed for these conditions, appropriate steps should be taken to ensure proper operation (see 7.6.2.4, second paragraph).

6.1.1 Ambient air temperature

6.1.1.1 Ambient air temperature for indoor installations

The ambient air temperature does not exceed +40 °C and its average over a period of 24 h does not exceed +35 °C.

The lower limit of the ambient air temperature is –5 °C.

6.1.1.2 Ambient air temperature for outdoor installations

The ambient air temperature does not exceed +40 °C and its average over a period of 24 h does not exceed +35 °C.

The lower limit of the ambient air temperature is:

- –25 °C in a temperate climate, and
- –50 °C in an arctic climate.

NOTE The use of ASSEMBLIES in an arctic climate may require a special agreement between manufacturer and user.

6.1.2 Atmospheric conditions

6.1.2.1 Atmospheric conditions for indoor installations

The air is clean and its relative humidity does not exceed 50 % at a maximum temperature of +40 °C. Higher relative humidities may be permitted at lower temperatures, for example 90 % at +20 °C. Care should be taken of moderate condensation which may occasionally occur due to variations in temperature.

6.1.2.2 Atmospheric conditions for outdoor installations

The relative humidity may temporarily be as high as 100 % at a maximum temperature of +25 °C.

6.1.2.3 Pollution degree

The pollution degree (see 2.9.10) refers to the environmental conditions for which the ASSEMBLY is intended.

For switching devices and components inside an enclosure, the pollution degree of the environmental conditions in the enclosure is applicable.

For the purpose of evaluating clearances and creepage distances, the following four degrees of pollution in the micro-environment are established (clearances and creepage distances according to the different pollution degrees are given in tables 14 and 16).

Pollution degree 1:

No pollution or only dry, non-conductive pollution occurs.

Pollution degree 2:

Normally, only non-conductive pollution occurs. Occasionally, however, a temporary conductivity caused by condensation may be expected.

Pollution degree 3:

Conductive pollution occurs or dry, non-conductive pollution occurs which becomes conductive due to condensation.

Pollution degree 4:

The pollution generates persistent conductivity caused, for instance, by conductive dust or by rain or snow.

Standard pollution degree of industrial applications:

Unless otherwise stated, ASSEMBLIES for industrial applications are generally for use in a pollution degree 3 environment. However, other pollution degrees may be considered to apply, depending upon particular applications or the micro-environment.

NOTE The pollution degree of the micro-environment for the equipment may be influenced by installation in an enclosure.

6.1.3 Altitude

The altitude of the site of installation does not exceed 2 000 m (6 600 ft).

NOTE For electronic equipment to be used at altitudes above 1 000 m, it may be necessary to take into account the reduction of the dielectric strength and of the cooling effect of the air. Electronic equipment intended to operate in these conditions should be designed or used in accordance with an agreement between manufacturer and user.

6.2 Special service conditions

Where any of the following special service conditions exist, the applicable particular requirements shall be complied with or special agreements shall be made between user and manufacturer. The user shall inform the manufacturer if such exceptional service conditions exist.

Special service conditions are, for example:

6.2.1 Values of temperature, relative humidity and/or altitude differing from those specified in 6.1.

6.2.2 Applications where variations in temperature and/or air pressure take place at such a speed that exceptional condensation is liable to occur inside the ASSEMBLY.

6.2.3 Heavy pollution of the air by dust, smoke, corrosive or radioactive particles, vapours or salt.

6.2.4 Exposure to strong electric or magnetic fields.

6.2.5 Exposure to extreme temperatures, for example radiation from sun or furnaces.

6.2.6 Attack by fungus or small creatures.

6.2.7 Installation in locations where fire or explosion hazards exist.

6.2.8 Exposure to heavy vibration and shocks.

6.2.9 Installation in such a manner that the current-carrying capacity or breaking capacity is affected, for example equipment built into machines or recessed into walls.

6.2.10 Consideration of appropriate remedies against:

- conducted and radiated disturbances other than EMC;
- EMC disturbances in environments other than those described in annex H.

6.3 Conditions during transport, storage and erection

6.3.1 A special agreement shall be made between user and manufacturer if the conditions during transport, storage and erection, for example temperature and humidity conditions, differ from those defined in 6.1.

Unless otherwise specified, the following temperature range applies: during transport and storage, between $-25\text{ }^{\circ}\text{C}$ and $+55\text{ }^{\circ}\text{C}$ and, for short periods not exceeding 24 h, up to $+70\text{ }^{\circ}\text{C}$.

Equipment subjected to these extreme temperatures without being operated shall not undergo any irreversible damage and shall then operate normally in the specified conditions.

7 Design and construction

7.1 Mechanical design

7.1.1 General

The ASSEMBLIES shall be constructed only of materials capable of withstanding the mechanical, electrical and thermal stresses as well as the effects of humidity which are likely to be encountered in normal service. Parts of ASSEMBLIES which are made of insulating material shall provide a specified degree of resistance to abnormal heat and fire.

Protection against corrosion shall be ensured by the use of suitable materials or by the application of equivalent protective coatings to the exposed surface, taking account of the intended conditions of use and maintenance.

All enclosures or partitions including locking means for doors, withdrawable parts etc., shall be of a mechanical strength sufficient to withstand the stresses to which they may be subjected in normal service.

The apparatus and circuits in the ASSEMBLY shall be so arranged as to facilitate their operation and maintenance, and at the same time to ensure the necessary degree of safety.

7.1.2 Clearances, creepage distances and isolating distances

7.1.2.1 Clearances and creepage distances

Apparatus forming part of the ASSEMBLY shall have distances complying with the requirements of their relevant specifications, and these distances shall be maintained during normal service conditions.

When arranging apparatus within the ASSEMBLY, the specified creepage distances and clearances or rated impulse withstand voltages (U_{imp}) shall be complied with, taking into account the relevant service conditions.

For bare live conductors and terminations (e.g. busbars, connections between apparatus, cable lugs), the creepage distances and the clearances or impulse withstand voltages shall at least comply with those specified for the apparatus with which they are directly associated.

In addition, abnormal conditions such as a short circuit shall not permanently reduce the clearances or dielectric strength between busbars and/or connections other than cables below the values specified for the apparatus with which they are directly associated. See also 8.2.2.

For ASSEMBLIES tested according to 8.2.2.6 of this standard, minimum values are given in tables 14 and 16 and test voltages are given in 7.1.2.3.

7.1.2.2 Isolation of withdrawable parts

In the case of functional units being mounted on withdrawable parts, the isolation provided shall at least comply with the requirements in the relevant specification for disconnectors* with the equipment in new condition, taking account of the manufacturing tolerances and changes in dimensions due to wear.

7.1.2.3 Dielectric properties

When, for a circuit or circuits of an ASSEMBLY, a rated impulse withstand voltage is declared by the manufacturer, the requirements of 7.1.2.3.1 to 7.1.2.3.6 apply and the circuit(s) shall satisfy the dielectric tests and verifications specified in 8.2.2.6 and 8.2.2.7.

In the other cases, the circuits of an ASSEMBLY shall satisfy the dielectric tests specified in 8.2.2.2, 8.2.2.3, 8.2.2.4 and 8.2.2.5.

NOTE It should be kept in mind, however, that in this case the requirements of insulation co-ordination cannot be verified.

The concept of insulation co-ordination based on an impulse voltage rating is preferred.

7.1.2.3.1 General

The following requirements are based on the principles of IEC 60664-1 and provide the possibility of co-ordination of insulation of equipment with the conditions within the installation.

The circuit(s) of an ASSEMBLY shall be capable of withstanding the rated impulse withstand voltage (see 4.1.3) in accordance with the overvoltage category given in annex G or, where applicable, the corresponding a.c. or d.c. voltage given in table 13. The withstand voltage across the isolation distances of devices suitable for isolation or of withdrawable parts is given in table 15.

NOTE The correlation between the nominal voltage of the supply system and the rated impulse withstand voltage of the circuit(s) of an ASSEMBLY is given in annex G.

The rated impulse withstand voltage for a given rated operational voltage shall not be less than that corresponding in annex G to the nominal voltage of the supply system of the circuit at the point where the ASSEMBLY is to be used, and the appropriate overvoltage category.

7.1.2.3.2 Impulse withstand voltage of the main circuit

- a) Clearances from live parts to parts intended to be earthed and between poles shall withstand the test voltage given in table 13 appropriate to the rated impulse withstand voltage.

* See IEC 60947-3.

- b) Clearances across the open contacts for withdrawable parts in the isolated position shall withstand the test voltage given in table 15 appropriate to the rated impulse withstand voltage.
- c) Solid insulation of ASSEMBLIES associated with clearances a) and/or b) shall withstand the impulse voltages specified in a) and/or b), as applicable.

7.1.2.3.3 Impulse withstand voltages of auxiliary circuits

- a) Auxiliary circuits which operate directly from the main circuit at the rated operational voltage without any means for reduction of overvoltage shall comply with the requirements of items a) and c) of 7.1.2.3.2.
- b) Auxiliary circuits which do not operate directly from the main circuit may have an overvoltage withstand capacity different from that of the main circuit. The clearances and associated solid insulation of such circuits – a.c. or d.c. – shall withstand the appropriate voltage in accordance with annex G.

7.1.2.3.4 Clearances

Clearances shall be sufficient to enable the circuits to withstand the test voltage, according to 7.1.2.3.2 and 7.1.2.3.3.

Clearances shall be at least as high as the values given in table 14, for case B – homogeneous field.

A test is not required if the clearances, related to the rated impulse withstand voltage and pollution degree, are higher than the values given in table 14 for case A – inhomogeneous field.

The method of measuring clearances is given in annex F.

7.1.2.3.5 Creepage distances

a) Dimensioning

For pollution degrees 1 and 2, creepage distances shall not be smaller than the associated clearances selected according to 7.1.2.3.4. For pollution degrees 3 and 4, the creepage distances shall not be less than the case A clearances to reduce the risk of disruptive discharge due to overvoltages, even if the clearances are smaller than the values for case A, as permitted in 7.1.2.3.4.

The method of measuring creepage distances is given in annex F.

Creepage distances shall correspond to a pollution degree as specified in 6.1.2.3 and to the corresponding material group at the rated insulation (or working) voltage given in table 16.

Material groups are classified as follows, according to the range of values of the comparative tracking index (CTI) (see 2.9.18):

- Material group I $600 \leq \text{CTI}$
- Material group II $400 \leq \text{CTI} < 600$
- Material group IIIa $175 \leq \text{CTI} < 400$
- Material group IIIb $100 \leq \text{CTI} < 175$

NOTE 1 The CTI values refer to the values obtained in accordance with IEC 60112, method A, for the insulating material used.

NOTE 2 For inorganic insulating materials, for example glass or ceramics, which do not track, creepage distances need not be greater than their associated clearances. However, the risk of disruptive discharge should be considered.

b) Use of ribs

A creepage distance can be reduced to 0,8 of the value of table 16 by using ribs of minimum height of 2 mm, irrespective of the number of ribs. The minimum base of the rib is determined by mechanical requirements (see clause F.2).

c) Special applications

Circuits intended for certain applications where severe consequences of an insulation fault have to be taken into account shall have one or more of the influencing factors of table 16 (distances, insulating materials, pollution in the micro-environment) utilized in such a way as to achieve a higher insulation voltage than the rated insulation voltage given to the circuits according to table 16.

7.1.2.3.6 Spacings between separate circuits

For dimensioning clearances, creepage distances and solid insulation between separate circuits, the highest voltage ratings shall be used (rated impulse withstand voltage for clearances and associated solid insulation, and rated insulation voltage for creepage distances).

7.1.3 Terminals for external conductors

7.1.3.1 The manufacturer shall indicate whether the terminals are suitable for connection of copper or aluminium conductors, or both. The terminals shall be such that the external conductors may be connected by a means (screws, connectors, etc.) which ensures that the necessary contact pressure corresponding to the current rating and the short-circuit strength of the apparatus and the circuit is maintained.

7.1.3.2 In the absence of a special agreement between manufacturer and user, terminals shall be capable of accommodating conductors and cables of copper from the smallest to the largest cross-sectional areas corresponding to the appropriate rated current (see annex A).

Where aluminium conductors are used, terminals which cater for the maximum size of solid or stranded conductors given in table A.1 are usually dimensionally adequate. In those instances where the use of this maximum size of aluminium conductor prevents the full utilization of the rated current of the circuit, it will be necessary, subject to agreement between manufacturer and user, to provide means of connection for an aluminium conductor of the next larger size.

In the case where external conductors for electronic circuits with low level currents and voltages (less than 1 A and less than 50 V a.c. or 120 V d.c.) have to be connected to an ASSEMBLY, table A.1 does not apply (see note 2 of table A.1).

7.1.3.3 The available wiring space shall permit proper connection of the external conductors of the indicated material and, in the case of multicore cables, spreading of the cores.

The conductors must not be subjected to stresses which reduce their normal life.

NOTE In the USA national regulations define the minimum wire bending space requirements for the proper connection of external conductors.

7.1.3.4 Unless otherwise agreed between manufacturer and user, on three-phase and neutral circuits, terminals for the neutral conductor shall allow the connection of copper conductors having a current-carrying capacity

- equal to half the current-carrying capacity of the phase conductor, with a minimum of 10 mm², if the size of the phase conductor exceeds 10 mm²;

- equal to the full current-carrying capacity of the phase conductor, if the size of the latter is less than or equal to 10 mm².

NOTE 1 For conductors other than copper conductors, the above cross-sections should be replaced by cross-sections of equivalent conductivity, which may require larger terminals.

NOTE 2 For certain applications in which the current in the neutral conductor may reach high values, for example large fluorescent lighting installations, a neutral conductor having the same current-carrying capacity as the phase conductors may be necessary, subject to special agreement between manufacturer and user.

7.1.3.5 If connecting facilities for incoming and outgoing neutral, protective and PEN conductors are provided, they shall be arranged in the vicinity of the associated phase conductor terminals.

7.1.3.6 Openings in cable entries, cover plates, etc., shall be so designed that, when the cables are properly installed, the stated protective measures against contact and degree of protection shall be obtained. This implies the selection of means of entry suitable for the application as stated by the manufacturer.

7.1.3.7 Identification of terminals

It is recommended that identification of terminals should comply with IEC 60445.

7.1.4 Resistance to abnormal heat and fire

Parts of insulating materials which might be exposed to thermal stresses due to electrical effects, and the deterioration of which might impair the safety of the ASSEMBLY, shall not be adversely affected by abnormal heat and by fire.

The suitability of these parts shall be verified by test in accordance with IEC 60695-2-10 and IEC 60695-2-11.

Parts of insulating materials necessary to retain current-carrying parts in position shall conform to the glow-wire test of 8.2.9 at a test temperature of 960 °C.

Parts of insulating materials other than those specified in the previous paragraph, including parts necessary to retain the protective conductor, shall conform to the requirements of the glow-wire test of 8.2.9 at a temperature of 650 °C.

This requirement does not apply to parts or components, which have been previously tested according to this standard or according to their own product standard.

For small parts (having surface dimensions not exceeding 14 mm × 14 mm), a different test may be selected (for example, the needle flame test of IEC 60695-2-2). The same procedure may be applicable for other practical reasons where the metal material of a part is large compared to the insulating material.

7.2 Enclosure and degree of protection

7.2.1 Degree of protection

7.2.1.1 The degree of protection provided by any ASSEMBLY against contact with live parts, ingress of solid foreign bodies and liquid is indicated by the designation IP... according to IEC 60529.

For ASSEMBLIES for indoor use where there is no requirement for protection against ingress of water, the following IP references are preferred:

IP00, IP2X, IP3X, IP4X, IP5X.

7.2.1.2 The degree of protection of an enclosed ASSEMBLY, or from the front of a dead-front ASSEMBLY, shall be at least IP2X, after installation in accordance with the manufacturer's instructions.

7.2.1.3 For ASSEMBLIES for outdoor use having no supplementary protection, the second characteristic numeral shall be at least 3.

NOTE For outdoor installation, supplementary protection may be protective roofing or the like.

7.2.1.4 Unless otherwise specified, the degree of protection indicated by the manufacturer applies to the complete ASSEMBLY when installed in accordance with the manufacturer's instructions (see also 7.1.3.6), for example sealing of the open mounting surface of an ASSEMBLY, if necessary.

The manufacturer shall also state the degree(s) of protection against direct contact, ingress of solid foreign bodies and liquids under conditions necessitating the accessibility to internal parts of the ASSEMBLY in service by authorized personnel (see 7.4.6). For ASSEMBLIES with moveable and/or withdrawable parts see 7.6.4.3.

7.2.1.5 If the degree of protection of part of the ASSEMBLY, for example on the operating face, differs from that of the main portion, the manufacturer shall indicate the degree of protection of that part separately. Example: IP00, operating face IP20.

7.2.1.6 For PTTA, no IP codes can be given unless the appropriate verifications can be made according to IEC 60529 or tested prefabricated enclosures are used.

7.2.2 Measures to take account of atmospheric humidity

In the case of an ASSEMBLY for outdoor installation and in the case of an enclosed ASSEMBLY for indoor installation intended for use in locations with high humidity and temperatures varying within wide limits, suitable arrangements (ventilation and/or internal heating, drain holes, etc.) shall be made to prevent harmful condensation within the ASSEMBLY. However, the specified degree of protection shall at the same time be maintained (for built-in apparatus, see 7.6.2.4).

7.3 Temperature rise

The temperature-rise limits given in table 2 apply for mean ambient air temperatures less than or equal to 35 °C and shall not be exceeded for ASSEMBLIES when verified in accordance with 8.2.1.

NOTE The temperature rise of an element or part is the difference between the temperature of this element or part measured in accordance with 8.2.1.5 and the ambient air temperature outside the ASSEMBLY.

Table 2 – Temperature-rise limits

Parts of ASSEMBLIES	Temperature rise K
Built-in components ¹⁾	In accordance with the relevant product standard requirements for the individual components or, in accordance with the component manufacturer's instructions ⁶⁾ , taking into consideration the temperature in the ASSEMBLY
Terminals for external insulated conductors	70 ²⁾
Busbars and conductors, plug-in contacts of removable or withdrawable parts which connect to busbars	Limited by: <ul style="list-style-type: none"> – mechanical strength of conducting material ⁷⁾; – possible effect on adjacent equipment; – permissible temperature limit of the insulating materials in contact with the conductor; – effect of the temperature of the conductor on the apparatus connected to it; – for plug-in contacts, nature and surface treatment of the contact material.
Manual operating means: <ul style="list-style-type: none"> – of metal – of insulating material 	<p style="text-align: right;">15 ³⁾</p> <p style="text-align: right;">25 ³⁾</p>
Accessible external enclosures and covers: <ul style="list-style-type: none"> – metal surfaces – insulating surfaces 	<p style="text-align: right;">30 ⁴⁾</p> <p style="text-align: right;">40 ⁴⁾</p>
Discrete arrangements of plug and socket-type connections	Determined by the limit for those components of the related equipment of which they form part ⁵⁾
<p>1) The term "built-in components" means:</p> <ul style="list-style-type: none"> – conventional switchgear and controlgear; – electronic sub-assemblies (e.g. rectifier bridge, printed circuit); – parts of the equipment (e.g. regulator, stabilized power supply unit, operational amplifier). <p>2) The temperature-rise limit of 70 K is a value based on the conventional test of 8.2.1. An ASSEMBLY used or tested under installation conditions may have connections, the type, nature and disposition of which will not be the same as those adopted for the test, and a different temperature rise of terminals may result and may be required or accepted. Where the terminals of the built-in component are also the terminals for external insulated conductors, the lower of the corresponding temperature-rise limits shall be applied.</p> <p>3) Manual operating means within ASSEMBLIES which are only accessible after the ASSEMBLY has been opened, for example draw-out handles which are operated infrequently, are allowed to assume a 25 K increase on these temperature-rise limits.</p> <p>4) Unless otherwise specified, in the case of covers and enclosures, which are accessible but need not be touched during normal operation, a 10 K increase on these temperature-rise limits is permissible.</p> <p>5) This allows a degree of flexibility in respect of equipment (e.g. electronic devices) which is subject to temperature-rise limits different from those normally associated with switchgear and controlgear.</p> <p>6) For temperature-rise tests according to 8.2.1, the temperature-rise limits have to be specified by the manufacturer of the ASSEMBLY.</p> <p>7) Assuming all other criteria listed are met, a maximum temperature rise of 105 K for bare copper busbars and conductors shall not be exceeded. The 105 K relates to the temperature above which annealing of copper is likely to occur.</p>	

7.4 Protection against electric shock

The following requirements are intended to ensure that the required protective measures are obtained when an ASSEMBLY is installed in a system conforming to the relevant specification.

For generally accepted protective measures refer to IEC 60364-4-41.

Those protective measures which are of particular importance for an ASSEMBLY are reproduced in detail below, taking into account the specific needs of ASSEMBLIES.

7.4.1 Protection against both direct and indirect contact

7.4.1.1 Protection by safety extra-low voltage

(See clause 411.1 of IEC 60364-4-41.)

7.4.2 Protection against direct contact (see 2.6.8)

Protection against direct contact can be obtained either by appropriate constructional measures on the ASSEMBLY itself or by additional measures to be taken during installation; this may require information given by the manufacturer.

An example of additional measures to be taken is the installation of an open-type ASSEMBLY without further provisions in a location where access is only permitted for authorized personnel.

One or more of the protective measures defined below may be selected, taking into account the requirements laid down in the following sub-clauses. The choice of the protective measure shall be subject to an agreement between manufacturer and user.

NOTE Information given in the manufacturer's catalogues may take the place of such an agreement.

7.4.2.1 Protection by insulation of live parts

Live parts shall be completely covered with insulation which can only be removed by destruction.

This insulation shall be made of suitable materials capable of durably withstanding the mechanical, electrical and thermal stresses to which the insulation may be subjected in service.

NOTE Examples are electrical components embedded in insulation, cables.

Paints, varnishes, lacquers and similar products alone are generally not considered to provide an adequate insulation for protection against electric shock in normal service.

7.4.2.2 Protection by barriers or enclosures

The following requirements shall be complied with.

7.4.2.2.1 All external surfaces shall conform to a degree of protection against direct contact of at least IP2X or IPXXB. The distance between the mechanical means provided for protection and the live parts they protect shall not be less than the values specified for the clearances and creepage distances in 7.1.2, unless the mechanical means are of insulating material.

7.4.2.2.2 All barriers and enclosures shall be firmly secured in place. Taking into account their nature, size and arrangement, they shall have sufficient stability and durability to resist the strains and stresses likely to occur in normal service without reducing the clearances according to 7.4.2.2.1.

7.4.2.2.3 Where it is necessary to make provision for the removal of barriers, opening of enclosures, or withdrawal of parts of enclosures (doors, casings, lids, covers and the like), this shall be in accordance with one of the following requirements.

- a) Removal, opening or withdrawal shall necessitate the use of a key or tool.
- b) All live parts which can unintentionally be touched after the door has been opened shall be isolated before the door can be opened. In TN-C systems, the PEN conductor shall not be isolated or switched. In TN-S systems, the neutral conductor need not be isolated or switched (see IEC 60364-4-46).

Example: By interlocking the door(s) with a disconnecter so that they can only be opened when the disconnecter is open and it shall not be possible to close the disconnecter while the door is open, except by overriding the interlock or using a tool.

If, for reasons of operation, the ASSEMBLY is fitted with a device permitting authorized persons to obtain access to live parts while the equipment is live, the interlock shall automatically be restored on reclosing the door(s).

- c) The ASSEMBLY shall include an internal obstacle or shutter shielding all live parts in such a manner that they cannot unintentionally be touched when the door is open. This obstacle or shutter shall meet the requirements of 7.4.2.2.1 (for exceptions, see item d)) and 7.4.2.2.2. It shall either be fixed in place or shall slide into place the moment the door is opened. It shall not be possible to remove this obstacle or shutter except by the use of a key or tool.

It may be necessary to provide warning labels.

- d) Where any parts behind a barrier or inside an enclosure need occasional handling (such as replacement of a lamp or of a fuse-link), the removal, opening or withdrawal without the use of a key or tool and without switching off shall be possible only if the following conditions are fulfilled (see 7.4.6):
 - an obstacle shall be provided behind the barrier or inside the enclosure so as to prevent persons from coming unintentionally into contact with live parts not protected by another protective measure. However, this obstacle need not prevent persons from coming intentionally into contact by by-passing this obstacle with the hand. It shall not be possible to remove the obstacle except through the use of a key or tool;
 - live parts, the voltage of which fulfils the conditions for the safety extra-low voltage, need not be covered.

7.4.2.3 Protection by obstacles

This measure applies to open-type ASSEMBLIES, see clause 412.3 of IEC 60364-4-41).

7.4.3 Protection against indirect contact (see 2.6.9)

The user shall indicate the protective measure which is applied to the installation for which the ASSEMBLY is intended. In particular, attention is drawn to IEC 60364-4-41, where requirements for protection against indirect contact are specified for the complete installation, for example the use of protective conductors.

7.4.3.1 Protection by using protective circuits

A protective circuit in an ASSEMBLY consists of either a separate protective conductor or the conductive structural parts, or both. It provides the following:

- protection against the consequences of faults within the ASSEMBLY;
- protection against the consequences of faults in external circuits supplied through the ASSEMBLY.

The requirements to be complied with are given in the following sub-clauses.

7.4.3.1.1 Constructional precautions shall be taken to ensure electrical continuity between the exposed conductive parts of the ASSEMBLY (see 7.4.3.1.5), and between these parts and the protective circuits of the installation (see 7.4.3.1.6).

For PTTA, unless a type-tested arrangement is used, or verification of the short-circuit strength is not necessary in accordance with 8.2.3.1.1 to 8.2.3.1.3, a separate protective conductor shall be used for the protective circuit and shall be so disposed with respect to the busbars that the effects of electromagnetic forces are negligible.

7.4.3.1.2 Certain exposed conductive parts of an ASSEMBLY which do not constitute a danger

- either because they cannot be touched on large surfaces or grasped with the hand,
- or because they are of small size (approximately 50 mm by 50 mm) or so located as to exclude any contact with live parts,

need not be connected to the protective circuits. This applies to screws, rivets and nameplates. It also applies to electromagnets of contactors or relays, magnetic cores of transformers (unless they are provided with a terminal for connection to the protective conductor), certain parts of releases, etc., irrespective of their size.

7.4.3.1.3 Manual operating means (handles, wheels, etc.) shall be

- either electrically connected, in a secure and permanent manner, with the parts connected to the protective circuits,
- or provided with additional insulation which insulates them from other conductive parts of the ASSEMBLY. This insulation shall be rated for at least the maximum rated insulation voltage of the associated device.

It is preferable that parts of manual operating means that are normally grasped by the hand during operation are made of or covered by insulating material rated for the maximum rated insulation voltage of the equipment.

7.4.3.1.4 Metal parts covered with a layer of varnish or enamel cannot generally be considered to be adequately insulated to comply with these requirements.

7.4.3.1.5 Continuity of protective circuits shall be ensured by effective interconnections either directly or by means of protective conductors.

- a) When a part of the ASSEMBLY is removed from the enclosure, for example for routine maintenance, the protective circuits for the remainder of the ASSEMBLY shall not be interrupted.

Means used for assembling the various metal parts of an ASSEMBLY are considered sufficient for ensuring continuity of the protective circuits if the precautions taken guarantee permanent good conductivity and a current-carrying capacity sufficient to withstand the earth fault current that may flow in the ASSEMBLY.

NOTE Flexible metal conduits should not be used as protective conductors.

- b) When removable or withdrawable parts are equipped with metal supporting surfaces, these surfaces are considered sufficient for ensuring continuity of the protective circuits provided that the pressure exerted on them is sufficiently high. Precautions may have to be taken to guarantee permanent good conductivity. The continuity of the protective circuit of a withdrawable part shall remain effective from the connected position to the isolated position inclusively.
- c) For lids, doors, cover plates and the like, the usual metal screwed connections and metal hinges are considered sufficient to ensure continuity provided that no electrical equipment is attached to them.

If apparatus with a voltage exceeding the limits of extra-low voltage are attached to lids, doors, cover plates, etc., steps shall be taken to ensure continuity of the protective circuits. It is recommended that these parts be fitted with a protective conductor (PE) whose cross-sectional area is in accordance with table 3A depending on the highest rated operational current I_e of the apparatus. An equivalent electrical connection especially designed for this purpose (sliding contact, hinges protected against corrosion) shall also be considered satisfactory.

- d) All parts of the protective circuit within the ASSEMBLY shall be so designed that they are capable of withstanding the highest thermal and dynamic stresses that may occur at the place of installation of the ASSEMBLY.
- e) When the enclosure of an ASSEMBLY is used as part of a protective circuit, the cross-sectional area of this enclosure shall be at least electrically equivalent to the minimum cross-sectional area specified in 7.4.3.1.7.
- f) Where continuity can be interrupted by means of connectors or plug-and-socket devices, the protective circuit shall be interrupted only after the live conductors have been interrupted and continuity shall be established before the live conductors are reconnected.
- g) In principle, with the exception of the cases mentioned under item f), protective circuits within an ASSEMBLY shall not include a disconnecting device (switch, disconnector, etc.). The only means permitted in the run of protective conductors shall be links which are removable by means of a tool and accessible only to authorized personnel (these links may be required for certain tests).

7.4.3.1.6 The terminals for external protective conductors and metal sheathing shall, where required, be bare and, unless otherwise specified, suitable for the connection of copper conductors. A separate terminal of adequate size shall be provided for the outgoing protective conductor(s) of each circuit. In the case of enclosures and conductors of aluminium or aluminium alloys, particular consideration shall be given to the danger of electrolytic corrosion. In the case of ASSEMBLIES with conductive structures, enclosures, etc., means shall be provided to ensure electrical continuity between the exposed conductive parts (the protective circuit) of the ASSEMBLY and the metal sheathing of connecting cables (steel conduit, lead sheath, etc.). The connecting means to ensure the continuity of the exposed conductive parts with external protective conductors shall have no other function.

NOTE Special precautions may be necessary with metal parts of the ASSEMBLY, particularly gland plates, where abrasion resistant finishes, for example powder coatings, are used.

7.4.3.1.7 The cross-sectional area of protective conductors (PE, PEN) in an ASSEMBLY to which external conductors are intended to be connected shall be determined in one of the following ways.

- a) The cross-sectional area of the protective conductors (PE, PEN) shall be not less than the appropriate value shown in table 3.

If the application of this table produces non-standard sizes, protective conductors (PE, PEN) having the nearest larger standard cross-sectional area are to be used.

Table 3 – Cross-sectional area of protective conductors (PE, PEN)

Cross-sectional area of phase conductors S mm ²	Minimum cross-sectional area of the corresponding protective conductor (PE, PEN) S_p mm ²
$S \leq 16$	S
$16 < S \leq 35$	16
$35 < S \leq 400$	$S/2$
$400 < S \leq 800$	200
$800 < S$	$S/4$

The values in table 3 are valid only if the protective conductor (PE, PEN) is made of the same metal as the phase conductors. If this is not so, the cross-sectional area of the protective conductor (PE, PEN) is to be determined in a manner which produces a conductance equivalent to that which results from the application of table 3.

For PEN conductors, the following additional requirements shall apply:

- the minimum cross-sectional area shall be 10 mm² Cu or 16 mm² Al;
- the PEN conductors need not be insulated within an ASSEMBLY;
- structural parts shall not be used as a PEN conductor. However, mounting rails made of copper or aluminium may be used as PEN conductors;
- table 3 assumes that the neutral conductor currents do not exceed 30 % of the phase currents;

- for certain applications in which the current in the PEN conductor may reach high values, for example large fluorescent lighting installations, a PEN conductor having the same or higher current-carrying capacity as the phase conductors may be necessary, subject to special agreement between manufacturer and user.
- b) The cross-sectional area of the protective conductor (PE, PEN) shall be calculated with the aid of the formula indicated in annex B or obtained by some other method, for example by testing.

For determining the cross-section of protective conductors (PE, PEN), the following conditions have to be satisfied simultaneously:

- 1) when the test according to 8.2.4.2 is carried out, the value of the fault-loop impedance shall fulfil the conditions required for the operation of the protective device;
- 2) the conditions of operation of the electrical protective device shall be so chosen as to eliminate the possibility of the fault current in the protective conductor (PE, PEN) causing a temperature rise that tends to impair this conductor or its electrical continuity.

7.4.3.1.8 In the case of an ASSEMBLY containing structural parts, frameworks, enclosures, etc., made of conducting material, a protective conductor, if provided, need not be insulated from these parts (for exceptions, see 7.4.3.1.9).

7.4.3.1.9 Conductors to certain protective devices including the conductors connecting them to a separate earth electrode shall be carefully insulated. This applies, for instance, to voltage-operated fault detection devices and can also apply to the earth-connection of the transformer neutral.

NOTE Attention is drawn to the special precautions to be taken in applying the requirements relating to such devices.

7.4.3.1.10 Exposed conductive parts of a device which cannot be connected to the protective circuit by the fixing means of the device shall be connected to the protective circuit of the ASSEMBLY for protective bonding by a conductor whose cross-sectional area is chosen according to table 3A.

Table 3A – Cross-sectional area of a copper bonding conductor

Rated operational current I_e A	Minimum cross-sectional area of a bonding conductor mm ²
$I_e \leq 20$	S*
$20 < I_e \leq 25$	2,5
$25 < I_e \leq 32$	4
$32 < I_e \leq 63$	6
$63 < I_e$	10

* S = cross-sectional area of the phase conductor (mm²).

7.4.3.2 Protection by measures other than using protective circuits

ASSEMBLIES can provide protection against indirect contact by means of the following measures which do not require a protective circuit:

- electrical separation of circuits;
- total insulation.

7.4.3.2.1 Electrical separation of circuits

(See clause 413.5 of IEC 60364-4-41.)

7.4.3.2.2 Protection by total insulation*

For protection, by total insulation, against indirect contact, the following requirements shall be met.

- a) The apparatus shall be completely enclosed in insulating material. The enclosure shall carry the symbol which shall be visible from the outside.
- b) The enclosure shall be made of an insulating material which is capable of withstanding the mechanical, electrical and thermal stresses to which it is liable to be subjected under normal or special service conditions (see 6.1 and 6.2) and it shall be resistant to ageing and flame-resistant.
- c) The enclosure shall at no point be pierced by conducting parts in such a manner that there is the possibility of a fault voltage being brought out of the enclosure.

This means that metal parts, such as actuator shafts which for constructional reasons have to be brought through the enclosure, shall be insulated on the inside or the outside of the enclosure from the live parts for the maximum rated insulation voltage and, if applicable, the maximum rated impulse withstand voltage of all circuits in the ASSEMBLY.

If an actuator is made of metal (whether covered by insulating material or not), it shall be provided with insulation rated for the maximum rated insulation voltage and, if applicable, the maximum impulse withstand voltage of all circuits in the ASSEMBLY.

If an actuator is principally made of insulating material, any of its metal parts which may become accessible in the event of insulation failure shall also be insulated from live parts for the maximum rated insulation voltage and, if applicable, the maximum rated impulse withstand voltage of all circuits in the ASSEMBLY.

- d) The enclosure, when the ASSEMBLY is ready for operation and connected to the supply, shall enclose all live parts, exposed conductive parts and parts belonging to a protective circuit in such a manner that they cannot be touched. The enclosure shall give at least the degree of protection IP2XC*.

If a protective conductor, which is extended to electrical equipment connected to the load side of the ASSEMBLY, is to be passed through an ASSEMBLY whose exposed conductive parts are insulated, the necessary terminals for connecting the external protective conductors shall be provided and identified by suitable marking.

Inside the enclosure, the protective conductor and its terminal shall be insulated from the live parts and the exposed conductive parts in the same way as the live parts are insulated.

* According to 413.2.1.1 of IEC 60364-4-41, this is equivalent to Class II equipment.

* See IEC 60529.

- e) Exposed conductive parts within the ASSEMBLY shall not be connected to the protective circuit, i.e. they shall not be included in a protective measure involving the use of a protective circuit. This applies also to built-in apparatus, even if they have a connecting terminal for a protective conductor.
- f) If doors or covers of the enclosure can be opened without the use of a key or tool, an obstacle of insulating material shall be provided which will afford protection against unintentional contact not only with the accessible live parts, but also with the exposed conductive parts which are only accessible after the cover has been opened; this obstacle, however, shall not be removable except with the use of a tool.

7.4.4 Discharging of electrical charges

If the ASSEMBLY contains items of equipment which may retain dangerous electrical charges after they have been switched off (capacitors, etc.), a warning plate is required.

Small capacitors such as those used for arc extinction, for delaying the response of relays, etc., shall not be considered dangerous.

NOTE Unintentional contact is not considered dangerous if the voltages resulting from static charges fall below 120 V d.c. in less than 5 s after disconnection from the power supply.

7.4.5 Operating and maintenance gangways within ASSEMBLIES (see 2.7.1 and 2.7.2)

Operating and maintenance gangways within an ASSEMBLY have to comply with the requirements of IEC 60364-4-481.

NOTE Recesses within ASSEMBLIES of limited depth of the order of 1 m are not considered to be gangways.

7.4.6 Requirements related to accessibility in service by authorized personnel

For accessibility in service by authorized personnel, as agreed between manufacturer and user, one or more of the following requirements shall be fulfilled subject to agreement between manufacturer and user. These requirements shall be complementary to the protective measures specified in 7.4.

NOTE This implies that the agreed requirements are valid when an authorized person can obtain access to the ASSEMBLY, for example by the use of tools or by overriding an interlock (see 7.4.2.2.3), when the ASSEMBLY or part of it is under voltage.

7.4.6.1 Requirements related to accessibility for inspection and similar operations

The ASSEMBLY shall be designed and arranged in such a way that certain operations, according to agreement between manufacturer and user, can be performed when the ASSEMBLY is in service and under voltage.

Such operations may be:

- visual inspection of
 - switching devices and other apparatus,
 - settings and indicators of relays and releases,
 - conductor connections and marking;

- adjusting and resetting of relays, releases and electronic devices;
- replacement of fuse-links;
- replacement of indicating lamps;
- certain fault location operations, for example voltage and current measuring with suitably designed and insulated devices.

7.4.6.2 Requirements related to accessibility for maintenance

To enable maintenance agreed upon between manufacturer and user on an isolated functional unit or group of the ASSEMBLY, with adjacent functional units or groups still under voltage, necessary measures shall be taken. The choice, which is subject to agreement between manufacturer and user, depends on such factors as service conditions, frequency of maintenance, competence of the authorized personnel, local installation rules, etc. Such measures include the selection of an appropriate form of separation (see 7.7) and may also be:

- sufficient space between the actual functional unit or group and adjacent functional units or groups. It is recommended that parts likely to be removed for maintenance have, as far as possible, retainable fastening means;
- use of barriers designed and arranged to protect against direct contact with equipment in adjacent functional units or groups;
- use of compartments for each functional unit or group;
- insertion of additional protective means provided or specified by the manufacturer.

7.4.6.3 Requirements related to accessibility for extension under voltage

When it is required to enable future extension of the ASSEMBLY with additional functional units or groups, with the rest of the ASSEMBLY still under voltage, the requirements specified in 7.4.6.2 apply, subject to agreement between manufacturer and user. These requirements also apply for the insertion and connection of additional outgoing cables when the existing cables are under voltage.

The extension of busbars and connection of additional units to their incoming supply shall not be made under voltage, unless the design of the ASSEMBLY permits such connections.

7.5 Short-circuit protection and short-circuit withstand strength

NOTE For the time being, this subclause applies primarily to a.c. equipment. Requirements concerning d.c. equipment are under consideration.

7.5.1 General

ASSEMBLIES shall be so constructed as to be capable of withstanding the thermal and dynamic stresses resulting from short-circuit currents up to the rated values.

NOTE The short-circuit stresses may be reduced by the use of current-limiting devices (inductances, current-limiting fuses or other current-limiting switching devices).

ASSEMBLIES shall be protected against short-circuit currents by means of, for example, circuit-breakers, fuses or combinations of both, which may either be incorporated in the ASSEMBLY or arranged outside it.

NOTE For ASSEMBLIES intended for use in IT systems*, the short-circuit protective device should have a sufficient breaking capacity on each single pole at line-to-line voltage to clear a double earth fault.

When ordering an ASSEMBLY, the user shall specify the short-circuit conditions at the point of installation.

NOTE It is desirable that the highest possible degree of protection to personnel should be provided in case of a fault leading to arcing inside an ASSEMBLY, although the prime object should be to avoid such arcs by suitable design or to limit their duration.

For PTTA, it is recommended to use type-tested arrangements, for example busbars, unless the exemptions given in 8.2.3.1.1 to 8.2.3.1.3 apply. In exceptional cases, where the use of type-tested arrangements is not possible, the short-circuit withstand strength of such parts (see 8.2.3.2.6) shall be verified by extrapolation from similar type-tested arrangements (see IEC 60865 and IEC 61117).

7.5.2 Information concerning short-circuit withstand strength

7.5.2.1 For an ASSEMBLY having only one incoming unit, the manufacturer shall state the short-circuit withstand strength as follows.

7.5.2.1.1 For ASSEMBLIES with a short-circuit protective device (SCPD) incorporated in the incoming unit, the manufacturer shall indicate the maximum allowable value of prospective short-circuit current at the terminals of the incoming unit. This value shall not exceed the appropriate rating(s) (see 4.3, 4.4, 4.5 and 4.6). The corresponding power factor and peak values shall be those shown in 7.5.3.

If the short-circuit protective device is a fuse or a current-limiting circuit-breaker, the manufacturer shall state the characteristics of the SCPD (current rating, breaking capacity, cut-off current, I^2t , etc.).

If a circuit breaker with time-delay release is used, the manufacturer shall state the maximum time-delay and the current setting corresponding to the indicated prospective short-circuit current.

7.5.2.1.2 For ASSEMBLIES where the short-circuit protective device is not incorporated in the incoming unit, the manufacturer shall indicate the short-circuit withstand strength in one or more of the following ways:

- a) rated short-time withstand current together with the associated time if different from 1 s (see 4.3) and rated peak withstand current (see 4.4);

NOTE For times up to a maximum of 3 s, the relationship between the rated short-time withstand current and the associated time is given by the formula $I^2t = \text{constant}$, provided that the peak value does not exceed the rated peak withstand current.

- b) rated conditional short-circuit current (see 4.5);

For item b), the manufacturer shall indicate the characteristics (current rating, breaking capacity, cut-off current, I^2t , etc.) of the short-circuit protective devices necessary for the protection of the ASSEMBLY.

NOTE When replacement of fuse-links is necessary, it is assumed that fuse-links with the same characteristics are used.

* See IEC 60364-3.

7.5.2.2 For an ASSEMBLY having several incoming units which are unlikely to be in operation simultaneously, the short-circuit withstand strength can be indicated for each of the incoming units in accordance with 7.5.2.1.

7.5.2.3 For an ASSEMBLY having several incoming units which are likely to be in operation simultaneously, and for an ASSEMBLY having one incoming unit and one or more outgoing units for high-power rotating machines likely to contribute to the short-circuit current, a special agreement shall be made to determine the values of the prospective short-circuit current in each incoming unit, in each outgoing unit and in the busbars.

7.5.3 Relationship between peak current and short-circuit current

For determining the electrodynamic stresses, the value of peak current shall be obtained by multiplying the short-circuit current by the factor n . Standard values for the factor n and the corresponding power factor are given in table 4.

Table 4 – Standard values for the factor n

RMS value of short-circuit current kA	$\cos \varphi$	n
$I \leq 5$	0,7	1,5
$5 < I \leq 10$	0,5	1,7
$10 < I \leq 20$	0,3	2
$20 < I \leq 50$	0,25	2,1
$50 < I$	0,2	2,2

NOTE Values of this table represent the majority of applications. In special locations, for example in the vicinity of transformers or generators, lower values of power factor may be found, whereby the maximum prospective peak current may become the limiting value instead of the r.m.s. value of the short-circuit current.

7.5.4 Co-ordination of short-circuit protective devices

7.5.4.1 The co-ordination of protective devices shall be the subject of an agreement between manufacturer and user. Information given in the manufacturer's catalogue may take the place of such an agreement.

7.5.4.2 If the operating conditions require maximum continuity of supply, the settings or selection of the short-circuit protective devices within the ASSEMBLY should, where possible, be so graded that a short circuit occurring in any outgoing branch circuit is cleared by the switching device installed in the faulted branch circuit without affecting the other outgoing branch circuits, thus ensuring selectivity of the protective system.

7.5.5 Circuits within an ASSEMBLY

7.5.5.1 Main circuits

7.5.5.1.1 The busbars (bare or insulated) shall be arranged in such a manner that an internal short circuit is not to be expected under normal operating conditions. Unless otherwise specified, they shall be rated in accordance with the information concerning the short-circuit withstand strength (see 7.5.2) and designed to withstand at least the short-circuit stresses limited by the protective device(s) on the supply side of the busbars.

7.5.5.1.2 Within a section, the conductors (including distribution busbars) between the main busbars and the supply side of functional units as well as the components included in these units may be rated on the basis of the reduced short-circuit stresses occurring on the load side of the respective short-circuit protective device within each unit, provided that these conductors are arranged so that under normal operating conditions, an internal short-circuit between phases and/or between phases and earth is only a remote possibility (see 7.5.5.3). Such conductors are preferably of solid rigid manufacture.

7.5.5.2 Auxiliary circuits

The design of the auxiliary circuits shall take into account the supply earthing system and ensure that an earth-fault or a fault between a live part and an exposed conductive part shall not cause unintentional dangerous operation.

In general, auxiliary circuits shall be protected against the effects of short circuits. However, a short-circuit protective device shall not be provided if its operation is liable to cause a danger. In such a case, the conductors of auxiliary circuits shall be arranged in such a manner that short circuits would not be expected under normal operating conditions (see 7.5.5.3).

7.5.5.3 Selection and installation of non-protected active conductors to reduce the possibility of short circuits

Active conductors in an ASSEMBLY that are not protected by short-circuit protective devices (see 7.5.5.1.2 and 7.5.5.2) shall be so selected and installed throughout the entire ASSEMBLY that, under normal operating conditions, an internal short circuit between phases or between phase and earth is only a remote possibility. Examples of conductor types and installation requirements are given in table 5.

Table 5 – Conductor selection and installation requirements

Type of conductor	Requirements
Bare conductors or single-core conductors with basic insulation, for example cables according to IEC 60227-3	Mutual contact or contact with conductive parts shall be avoided, for example by use of spacers.
Single-core conductors with basic insulation and a maximum permissible conductor-operating temperature of at least 90 °C, for example cables according to IEC 60245-3, or heat-resistant PVC insulated cables according to IEC 60227-3	Mutual contact or contact with conductive parts is permitted where there is no applied external pressure. Contact with sharp edges must be avoided. There must be no risk of mechanical damage. These conductors may only be loaded such that an operating temperature of 80 % of the maximum permissible conductor operating temperature is not exceeded.
Conductors with basic insulation, for example cables according to IEC 60227-3, having additional secondary insulation, for example individually covered cables with shrink sleeving or individually run cables in plastic conduits	No additional requirements if there is no risk of mechanical damage.
Conductors insulated with a very high mechanical strength material, for example ethylene tetrafluoro ethylene (ETFE) insulation, or double-insulated conductors with an enhanced outer sheath rated for use up to 3 kV, for example cables according to IEC 60502	
Single or multi-core sheathed cables, for example cables according to IEC 60245-4 or IEC 60227-4	
NOTE Bare or insulated conductors installed as in the table above and having a short-circuit protective device connected on the load side may be up to 3 m long.	

7.6 Switching devices and components installed in ASSEMBLIES

7.6.1 Selection of switching devices and components

Switching devices and components incorporated in ASSEMBLIES shall comply with the relevant IEC standards.

The switching devices and components shall be suitable for the particular application with respect to the external design of the ASSEMBLY (e.g. open type or enclosed), their rated voltages (rated insulation voltage, rated impulse withstand voltage, etc.), rated currents, rated frequency, service life, making and breaking capacities, short-circuit withstand strength, etc.

The switching devices and components having a short-circuit withstand strength and/or a breaking capacity which is insufficient to withstand the stresses likely to occur at the place of installation, shall be protected by means of current-limiting protective devices, for example fuses or circuit-breakers. When selecting current-limiting protective devices for built-in switching devices, account shall be taken of the maximum permissible values specified by the manufacturer of the device, having due regard to co-ordination (see 7.5.4).

Co-ordination of switching devices and components, for example co-ordination of motor starters with short-circuit protective devices, shall comply with the relevant IEC standards.

Switching devices and components in a circuit for which a rated impulse withstand voltage is declared by the manufacturer shall not generate switching overvoltages higher than the rated impulse withstand voltage of the circuit and shall not be subjected to switching overvoltages higher than the rated impulse withstand voltage of the circuit. The latter point should be taken into account when selecting switching devices and components for use in a given circuit.

Example:

Switching devices and components having a rated impulse voltage $U_{imp} = 4\ 000\ V$, a rated insulation voltage $U_i = 250\ V$ and a maximum switching overvoltage of $1\ 200\ V$ (at a rated operational voltage of $230\ V$) may be used in circuits of overvoltage categories I, II, III or even IV where appropriate overvoltage protective means are used.

NOTE For overvoltage category, see 2.9.12 and annex G.

7.6.2 Installation

Switching devices and components shall be installed in accordance with the instructions of their manufacturer (position of use, clearances to be observed for electric arcs or for the removal of the arc chute, etc.).

7.6.2.1 Accessibility

The apparatus, functional units mounted on the same support (mounting plate, mounting frame) and the terminals for external conductors shall be so arranged as to be accessible for mounting, wiring, maintenance and replacement. In particular, it is recommended that the terminals be situated at least $0,2\ m$ above the base of floor-mounted ASSEMBLIES and, moreover, be so placed that the cables can be easily connected to them.

Adjusting and resetting devices which have to be operated inside the ASSEMBLY shall be easily accessible.

In general, for floor-mounted ASSEMBLIES, indicating instruments which need to be read by the operator should not be located higher than 2 m above the base of the ASSEMBLY. Operating devices, such as handles, push buttons, etc., should be located at such a height that they can easily be operated; this means that in general their centreline should not be higher than 2 m above the base of the ASSEMBLY.

NOTE 1 Actuators for emergency switching devices (see IEC 60364-5-537, clause 537.4) should be accessible within a zone between 0,8 m and 1,6 m above servicing level.

NOTE 2 It is recommended that wall-mounted and floor-mounted ASSEMBLIES should be installed at such a height with respect to the operating level that the above requirements for accessibility and operating heights are met.

7.6.2.2 Interaction

The switching devices and components shall be installed and wired in the ASSEMBLY in such a manner that its proper functioning is not impaired by interaction, such as heat, arcs, vibrations, fields of energy, which are present in normal operation. In the case of electronic ASSEMBLIES, this may necessitate the separation or screening of monitoring circuits from power circuits.

In the case of enclosures designed to accommodate fuses, special consideration shall be given to thermal effects (see 7.3). The manufacturer shall state the type and rating of the fuse-links to be used.

7.6.2.3 Barriers

Barriers for manual switching devices shall be so designed that the switching arcs do not present a danger to the operator.

To minimize danger when replacing fuse-links, interphase barriers shall be applied, unless the design and location of the fuses makes this unnecessary.

7.6.2.4 Conditions existing at site of installation

The switching devices and components for ASSEMBLIES are selected on the basis of the normal service conditions of the ASSEMBLY specified in 6.1 (see also 7.6.2.2).

Where necessary, suitable precautions (heating, ventilation) shall be taken to ensure that the service conditions essential for proper functioning are maintained, for example the minimum temperature for correct operation of relays, meters, electronic components, etc., according to the relevant specifications.

7.6.2.5 Cooling

For ASSEMBLIES both natural and forced cooling may be provided. If special precautions are required at the place of installation to ensure proper cooling, the manufacturer shall furnish the necessary information (for instance indication of the need for clearances with respect to parts that are liable to impede the dissipation of heat or produce heat themselves).

7.6.3 Fixed parts

In the case of fixed parts (see 2.2.5), the connections of main circuits (see 2.1.2) can only be established or broken when the ASSEMBLY is dead. In general, removal and installation of fixed parts requires the use of a tool.

The disconnection of a fixed part may require the disconnection of the complete ASSEMBLY or part of it.

In order to prevent unauthorized operation, the switching device may be provided with means to secure it in one or more of its positions.

NOTE If under certain conditions working on the live circuits is allowed, the relevant safety precautions must be respected.

7.6.4 Removable parts and withdrawable parts

7.6.4.1 Design

The removable parts and withdrawable parts shall be so designed that their electrical equipment can be safely isolated from or connected to the main circuit whilst this circuit is live. The removable and withdrawable parts may be provided with an insertion interlock (see 2.4.17). Minimum clearances and creepage distances (see 7.1.2.1) shall be complied with in the different positions as well as during transfer from one position to another.

NOTE 1 It may be necessary to ensure that these operations are not performed under load.

Removable parts shall have a connected position (see 2.2.8) and a removed position (see 2.2.11).

Withdrawable parts shall have in addition an isolated position (see 2.2.10) and may have a test position (see 2.2.9), or a test situation (see 2.1.9). They shall be distinctly located in these positions. These positions shall be clearly discernible.

For the electrical conditions for the different positions of withdrawable parts, see table 6.

7.6.4.2 Interlocking and padlocking of withdrawable parts

Unless otherwise specified, withdrawable parts shall be fitted with a device which ensures that the apparatus can only be withdrawn and/or re-inserted after its main circuit has been interrupted.

In order to prevent unauthorized operation, withdrawable parts may be provided with means for a padlock or lock to secure them in one or more of their positions (see 7.1.1).

7.6.4.3 Degree of protection

The degree of protection (see 7.2.1) indicated for ASSEMBLIES normally applies to the connected position (see 2.2.8) of the removable and/or withdrawable parts. The manufacturer shall indicate the degree of protection obtained in the other positions and during the transfer between positions.

ASSEMBLIES with withdrawable parts may be so designed that the degree of protection applying to the connected position is also maintained in the test and isolated positions and during transfer from one position to another.

If, after the removal of a removable and/or withdrawable part, the original degree of protection is not maintained, an agreement shall be reached as to what measures shall be taken to ensure adequate protection. Information given in the manufacturer's catalogue may take the place of such an agreement.

7.6.4.4 Mode of connection of auxiliary circuits

Auxiliary circuits may be so designed that they can be opened with or without the use of a tool.













In the case of withdrawable parts, the connection of the auxiliary circuits shall preferably be possible without the use of tools.

7.6.5 Identification

7.6.5.1 Identification of the conductors of main and auxiliary circuits

With the exception of the cases mentioned in 7.6.5.2, the method and the extent of identification of conductors, for example by arrangement, colours or symbols, on the terminals to which they are connected or on the end(s) of the conductors themselves, is the responsibility of the manufacturer and shall be in agreement with the indications on the wiring diagrams and drawings. Where appropriate, the identification according to IEC 60445 and IEC 60446 shall be applied.

Table 6 – Electrical conditions for the different positions of withdrawable parts

Circuit	Method of connection	Position			
		Connected position (see 2.2.8)	Test situation/position (see 2.1.9/2.2.9)	Isolated position (see 2.2.10)	Removed position (see 2.2.11)
Incoming main circuit	Incoming line plug and socket or other connection facilities				
Outgoing main circuit	Outgoing line plug and socket or other connection facilities		 or ¹⁾	 or ¹⁾	
Auxiliary circuit	Plug and socket or similar connection facilities				
Condition of circuits within withdrawable parts		Live	Live Auxiliary circuits ready for operational testing	Dead if no backfeed is present	
Condition of outgoing ASSEMBLY terminals of main circuits		Live	Live or not disconnected ²⁾	Dead if no backfeed is present	Dead if no backfeed is present
The requirements of 7.4.4 shall be complied with.					
Earth continuity shall be in accordance with item b) of 7.4.3.1.5 and maintained until the isolating distance is established.					
1) Depending on design.					
2) Depending on the terminals being fed from alternative sources of supply such as a standby supply.					
 = connected  = isolated (occurs twice)  = open, but not necessarily disconnected (isolated)					

7.6.5.2 Identification of the protective conductor (PE, PEN) and of the neutral conductor (N) of the main circuits

The protective conductor shall be readily distinguishable by shape, location, marking or colour. If identification by colour is used, it must be green and yellow (twin-coloured). When the protective conductor is an insulated single-core cable, this colour identification shall be used, preferably throughout the whole length.

NOTE The green/yellow colour identification is strictly reserved for the protective conductor.

Any neutral conductor of the main circuit should be readily distinguishable by shape, location, marking or colour. If identification by colour is used, it is recommended to select a light blue colour.

The terminals for external protective conductors shall be marked according to IEC 60445. As an example see graphical symbol  No. 5019 of IEC 60417. This symbol is not required where the external protective conductor is intended to be connected to an internal protective conductor which is clearly identified with the colours green/yellow.

7.6.5.3 Direction of operation and indication of operational positions

The operational positions of components and devices shall be clearly identified. If the direction of operation is not in accordance with IEC 60447, then this direction shall be clearly identified.

7.6.5.4 Indicator lights and push-buttons

The colours of indicator lights and push-buttons are given in IEC 60073.

7.7 Internal separation of ASSEMBLIES by barriers or partitions

One or more of the following conditions can be attained by dividing ASSEMBLIES by means of partitions or barriers (metallic or non-metallic) into separate compartments or enclosed protected spaces:

- protection against contact with hazardous parts belonging to the adjacent functional units. The degree of protection shall be at least IPXXB;
- protection against the passage of solid foreign bodies from one unit of an ASSEMBLY to an adjacent unit. The degree of protection shall be at least IP2X.

NOTE The degree of protection IP2X covers the degree of protection IPXXB.

The following are typical forms of separation by barriers or partitions (for examples, see annex D).

Table 6A – Forms of internal separation

Main criteria	Subcriteria	Form
No internal separation		Form 1
Separation of busbars from the functional units	Terminals for external conductors not separated from busbars	Form 2a
	Terminals for external conductors separated from busbars	Form 2b
Separation of busbars from the functional units and separation of all functional units from one another. Separation of terminals for external conductors from the functional units, but not from those of other functional units	Terminals for external conductors not separated from busbars	Form 3a
	Terminals for external conductors separated from busbars	Form 3b
Separation of busbars from all functional units and separation of all functional units from one another. Separation of terminals for external conductors associated with a functional unit from those of any other functional unit and the busbars	Terminals for external conductors in the same compartment as the associated functional unit	Form 4a
	Terminals for external conductors not in the same compartment as the associated functional unit, but in individual, separate, enclosed protected spaces or compartments	Form 4b

The form of separation and higher degrees of protection shall be the subject of an agreement between manufacturer and user.

See 7.4.2.2.2 with regard to stability and durability of barriers and partitions.

See 7.4.6.2 with regard to accessibility for maintenance on isolated functional units.

See 7.4.6.3 with regard to accessibility for extension under voltage.

7.8 Electrical connections inside an ASSEMBLY: bars and insulated conductors

7.8.1 General

The connections of current-carrying parts shall not suffer undue alteration as a result of normal temperature rise, ageing of the insulating materials and vibrations occurring in normal operation. In particular, the effects of thermal expansion and of the electrolytic action in the case of dissimilar metals, and the effects of the endurance of the materials to the temperatures attained, shall be taken into consideration.

Connections between current-carrying parts shall be established by means which ensure a sufficient and durable contact pressure.

7.8.2 Dimensions and rating of busbars and insulated conductors

The choice of the cross-sections of conductors inside the ASSEMBLY is the responsibility of the manufacturer. In addition to the current which must be carried, the choice is governed by the mechanical stresses to which the ASSEMBLY is subjected, by the way these conductors are laid, by the type of insulation and, if applicable, by the kind of elements connected (e.g. electronics).

7.8.3 Wiring (see also 7.8.2)

7.8.3.1 The insulated conductors shall be rated for at least the rated insulation voltage (see 4.1.2) of the circuit concerned.

7.8.3.2 Cables between two connecting devices shall have no intermediate splices or soldered joints.

7.8.3.3 Insulated conductors shall not rest against bare live parts at different potentials or sharp edges and shall be adequately supported.

7.8.3.4 Supply leads to apparatus and measuring instruments in covers or doors shall be so installed that no mechanical damage can occur to the conductors as a result of movement of these covers or doors.

7.8.3.5 Soldered connections to apparatus shall be permitted in ASSEMBLIES only in cases where provision is made for this type of connection on the apparatus.

Where the equipment is subject to heavy vibration during normal operation, soldered cables or wire connections shall be mechanically secured by supplementary means at a short distance from the soldered joint.

7.8.3.6 In locations where heavy vibrations exist during normal operation, for example in the case of dredger and crane operation, operation on board of ships, lifting equipment and locomotives, attention should be given to the support of the conductors. For apparatus other than those mentioned in 7.8.3.5, soldering cable lugs or soldered ends of stranded conductors are not acceptable under conditions of heavy vibration.

7.8.3.7 Generally only one conductor should be connected to a terminal; the connection of two or more conductors to one terminal is permissible only in those cases where the terminals are designed for this purpose.

7.9 Requirements for electronic equipment supply circuits

Unless otherwise specified in the relevant IEC specifications for electronic equipment, the following requirements apply.

7.9.1 Input voltage variations*

- 1) The supply voltage range for battery sources is equal to the rated supply voltage $\pm 15\%$.
NOTE This range does not include the additional voltage range required for charging batteries.
- 2) The range of the input direct voltages is that which is obtained by rectification of the alternating supply voltage (see item 3).
- 3) The supply voltage range for a.c. sources is equal to the rated input voltage $\pm 10\%$.
- 4) If a wider tolerance is necessary, this is subject to agreement between manufacturer and user.

* In compliance with IEC 60146-2.

7.9.2 Overvoltages*

Supply overvoltages are specified in figure 1. This figure applies to the non-periodic overvoltages as a deviation from the rated peak value within the short-time range. The ASSEMBLIES shall be so designed that their service ability in the case of overvoltages below the values represented by curve 1 is ensured.

If overvoltages occur within the range between curves 1 and 2, the operation may be interrupted by the response of protective devices safeguarding the ASSEMBLY, no damage to the ASSEMBLY being allowed to occur up to a peak value of the voltage equal to $2 U_i + 1\,000\text{ V}$.

NOTE 1 Transient durations less than 1 ms are under consideration.

NOTE 2 Higher overvoltages than those given above are assumed to be limited by appropriate measures.

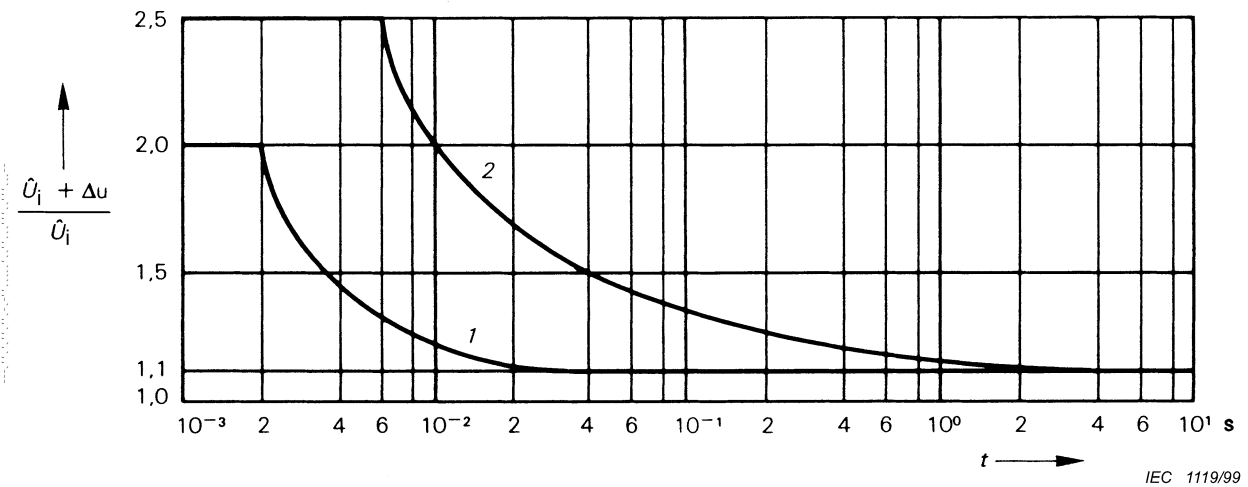

\hat{U}_i = sinusoidal peak value of rated insulation voltage

Δu = superimposed non-periodic peak voltage

t = time

Figure 1 – Ratio $\frac{\hat{U}_i + \Delta u}{\hat{U}_i}$ as a function of time

7.9.3 Waveform*

Harmonics of the input alternating voltage supplying ASSEMBLIES incorporating electronic equipment are restricted in the following limits.

- 1) The relative harmonic content shall not exceed 10 %, i.e. a relative fundamental content higher than or equal to 99,5 %.
- 2) Harmonic components shall not exceed the values given in figure 2.

NOTE 1 The sub-assembly is assumed to be disconnected and the internal impedance of the supply source should be specified in an agreement between manufacturer and user, if this impedance is of significant value.

NOTE 2 The same values are indicated for electronic control and monitoring.

- 3) The highest periodic momentary value of the a.c. supply voltage shall not be more than 20 % above the peak value of the fundamental.

* In accordance with IEC 60146-2.

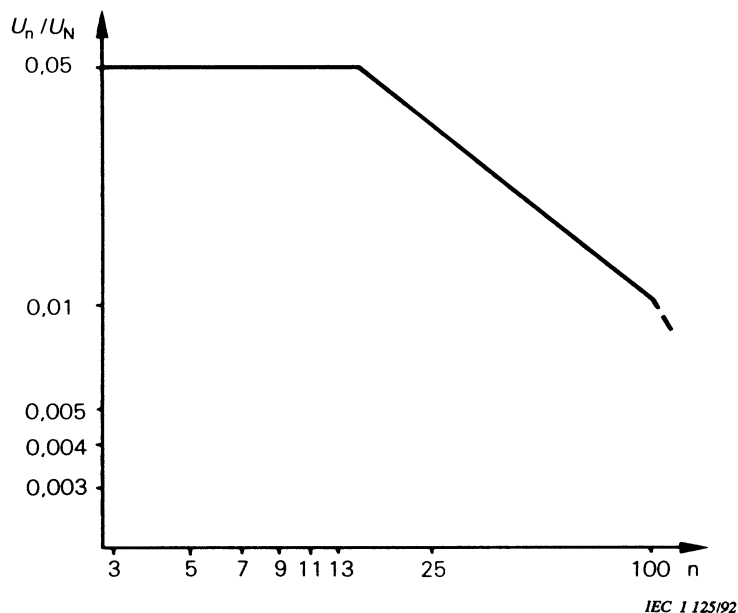

n = order of harmonic component

U_n = r.m.s. value of harmonic order n

U_N = r.m.s. value of nominal system voltage

Figure 2 – Maximum permitted harmonic component of the nominal system voltage

7.9.4 Temporary variations in voltage and frequency

The equipment shall operate without damage when there are temporary variations in the following conditions.

- a) Voltage drops not exceeding 15 % of rated voltage for periods not longer than 0,5 s.
- b) Supply frequency deviation of up to ± 1 % of rated frequency. If a wider tolerance is necessary, this is subject to agreement between manufacturer and user.
- c) The maximum admissible duration of an interruption of the supply voltage for equipment shall be indicated by the manufacturer.

7.10 Electromagnetic compatibility (EMC)

7.10.1 General

For the majority of ASSEMBY applications falling within the scope of this standard, two sets of environmental conditions are considered:

- a) Environment A;
- b) Environment B.

Environment A: relates to low-voltage non-public or industrial networks/locations/installations including highly disturbing sources.

NOTE 1 Environment A corresponds to Equipment Class A in CISPR 11 and in IEC 61000-6-4.

NOTE 2 Industrial locations are characterized by one or more of the following conditions:

- industrial, scientific and medical apparatus, e.g. working machines are present;
- heavy inductive or capacitive loads are frequently switched;
- currents and associated magnetic fields are high.

Environment B: relates to low-voltage public networks such as domestic, commercial and light industrial locations/installations. Highly disturbing sources such as arc welders are not covered by this environment.

NOTE 3 Environment B corresponds to Equipment Class B in CISPR 11 and in IEC 61000-6-3.

NOTE 4 The following list, although not comprehensive, gives an indication of locations which are included:

- residential properties, e.g. houses, apartments;
- retail outlets, e.g. shops, supermarkets;
- business premises, e.g. offices, banks;
- areas of public entertainment, e.g. cinemas, public bars, dance halls;
- outdoor locations, e.g. petrol stations, car parks, sport centres;
- light-industrial locations, e.g. workshops, laboratories, service centres.

The environmental condition A and/or B for which the ASSEMBLY is suitable shall be stated by the ASSEMBLY manufacturer.

7.10.2 Requirement for testing

ASSEMBLIES are in most cases manufactured or assembled on a one-off basis, incorporating a more-or-less random combination of devices and components.

No EMC immunity or emission tests are required on final ASSEMBLIES if the following conditions are fulfilled:

- a) The incorporated devices and components are in compliance with the requirements for EMC for the stated environment (see 7.10.1) as required by the relevant product or generic EMC standard.
- b) The internal installation and wiring is carried out in accordance with the devices and component manufacturers' instructions (arrangement with regard to mutual influences, cable, screening, earthing etc.).

In all other cases the EMC requirements shall be verified by tests as mentioned in H.8.2.8.

7.10.3 Immunity

7.10.3.1 ASSEMBLIES not incorporating electronic circuits

Under normal service conditions, ASSEMBLIES not incorporating electronic circuits are not sensitive to electromagnetic disturbances and therefore no immunity tests are required.

7.10.3.2 ASSEMBLIES incorporating electronic circuits

Electronic equipment incorporated in ASSEMBLIES shall comply with the immunity requirements of the relevant product or generic EMC standard and shall be suitable for the EMC environment stated by the ASSEMBLY manufacturer.

In all other cases, the EMC requirements shall be verified by tests as mentioned in H.8.2.8.

NOTE Equipment utilizing electronic circuits in which all components are passive (for example diodes, resistors, varistors, capacitors, surge suppressors, inductors) are not required to be tested.

The device and/or component manufacturer shall specify the specific performance criteria of his products based on the acceptance criteria given in the relevant product standard.

7.10.4 Emission

7.10.4.1 ASSEMBLIES not incorporating electronic circuits

For ASSEMBLIES not incorporating electronic circuits, electromagnetic disturbances can only be generated by equipment during occasional switching operations. The duration of the disturbances is in the order of some milliseconds. The frequency, level and consequences of these emissions are considered as part of the normal electromagnetic environment of low-voltage installations. Therefore, the requirements for electromagnetic emission are deemed to be satisfied, and no verification is necessary.

7.10.4.2 ASSEMBLIES incorporating electronic circuits

Electronic equipment incorporated in the ASSEMBLY shall comply with the emission requirements of the relevant product or generic EMC standard and shall be suitable for the specific EMC environment stated by the ASSEMBLY manufacturer.

7.10.4.2.1 Frequencies of 9 kHz or higher

ASSEMBLIES incorporating electronic circuits (such as switched mode power supplies, circuits incorporating microprocessors with high-frequency clocks) may generate continuous electromagnetic disturbances.

Such emissions shall not exceed the limits specified in the relevant product standard, or shall be based on table H.1 for Environment A and/or table H.2 for Environment B. These tests are only required when the main and/or auxiliary circuits contain components which have not been tested to the relevant product standard and with fundamental switching frequencies equal or greater than 9 kHz.

Tests shall be carried out as detailed in the relevant product standard, if any, otherwise according to H.8.2.8.

7.10.4.2.2 Frequencies lower than 9kHz

ASSEMBLIES incorporating electronic circuits which generate low-frequency harmonics on the mains supply shall comply with the requirements of IEC 61000-3-2 where applicable.

7.11 Description of the types of electrical connections of functional units

The types of electrical connections of functional units within ASSEMBLIES or parts of ASSEMBLIES can be denoted by a three-letter code:

- the first letter denotes the type of electrical connection of the main incoming circuit;
- the second letter denotes the type of electrical connection of the main outgoing circuit;
- the third letter denotes the type of electrical connection of the auxiliary circuits.

The following letters shall be used:

- F for fixed connections (see 2.2.12.1);
- D for disconnectable connections (see 2.2.12.2);
- W for withdrawable connections (see 2.2.12.3).

8 Test specifications

8.1 Classification of tests

The tests to verify the characteristics of an ASSEMBLY include:

- type tests (see 8.1.1 and 8.2)
- routine tests (see 8.1.2 and 8.3).

The manufacturer shall, on request, specify the basis for the verifications.

NOTE Verifications and tests to be performed on TTA and PTTA are listed in table 7.

8.1.1 Type tests (see 8.2)

Type tests are intended to verify compliance with the requirements laid down in this standard for a given type of ASSEMBLY.

Type tests will be carried out on a sample of such an ASSEMBLY or on such parts of ASSEMBLIES manufactured to the same or a similar design.

They shall be carried out on the initiative of the manufacturer.

Type tests include the following:

- a) verification of temperature-rise limits (8.2.1);
- b) verification of the dielectric properties (8.2.2);
- c) verification of the short-circuit withstand strength (8.2.3);
- d) verification of the effectiveness of the protective circuit (8.2.4);
- e) verification of clearances and creepage distances (8.2.5);
- f) verification of mechanical operation (8.2.6);
- g) verification of the degree of protection (8.2.7);
- h) EMC tests (see 7.10 and, if applicable, annex H).

These tests may be carried out in any order and/or on different samples of the same type.

If modifications are made to the components of the ASSEMBLY, new type tests have to be carried out only in so far as such modifications are likely to adversely affect the results of these tests.

8.1.2 Routine tests (see 8.3)

Routine tests are intended to detect faults in materials and workmanship. They are carried out on every new ASSEMBLY after it has been assembled or on each transport unit. Another routine test at the place of installation is not required.

ASSEMBLIES which are assembled from standardized components outside the works of the manufacturer of these components, by the exclusive use of parts and accessories specified or supplied by the manufacturer for this purpose, shall be routine-tested by the firm which has assembled the ASSEMBLY.

Routine tests include the following:

- a) inspection of the ASSEMBLY including inspection of wiring and, if necessary, electrical operation test (8.3.1);
- b) a dielectric test (8.3.2);
- c) checking of protective measures and of the electrical continuity of the protective circuit (8.3.3).

These tests may be carried out in any order.

NOTE The performance of the routine tests at the manufacturer's works does not relieve the firm installing the ASSEMBLY of the duty of checking it after transport and installation.

8.1.3 Testing of devices and self-contained components incorporated in the ASSEMBLY

Type tests or routine tests are not required to be carried out on devices and self-contained components incorporated in the ASSEMBLY when they have been selected in accordance with 7.6.1 and installed in accordance with the instructions of the manufacturer.

8.2 Type tests

8.2.1 Verification of temperature-rise limits

8.2.1.1 General

The temperature-rise test is designed to verify that the temperature-rise limits specified in 7.3 for the different parts of the ASSEMBLY are not exceeded.

The test shall normally be carried out at the values of rated current in accordance with 8.2.1.3, with the apparatus of the ASSEMBLY installed.

The test may be carried out with the aid of heating resistors of an equivalent power loss in accordance with 8.2.1.4.

It is permissible to test individual parts (panels, boxes, enclosures, etc.) of the ASSEMBLY (see 8.2.1.2), provided proper precautions are taken to make the test representative.

Temperature-rise tests on the main circuit(s) rated above 800 A carried out at 50 Hz are valid if the rated current at 60 Hz is reduced to 95 %. For rated currents up to 800 A, tests carried out at 50 Hz are normally applicable for 60 Hz.

The temperature-rise test on the individual circuits shall be made with the type of current for which they are intended, and at the design frequency. The test voltages used shall be such that a current equal to the current determined according to 8.2.1.3 flows through the circuits. Coils of relays, contactors, releases, etc., shall be supplied with rated voltage.

Open-type ASSEMBLIES need not be subjected to the temperature-rise test if it is obvious from type tests on the individual parts, or from the size of the conductors and from the arrangement of the apparatus, that there will be no excessive temperature rise and that no damage will be caused to the equipment connected to the ASSEMBLY and to adjacent parts of insulating material.

Table 7 – List of verifications and tests to be performed on TTA and PTТА

No.	Characteristics to be checked	Sub-clauses	TTA	PTТА
1	Temperature-rise limits	8.2.1	Verification of temperature-rise limits by test (type test)	Verification of temperature-rise limits by test or extrapolation
2	Dielectric properties	8.2.2	Verification of dielectric properties by test (type test)	Verification of dielectric properties by test according to 8.2.2 or 8.3.2, or verification of insulation resistance according to 8.3.4 (see Nos. 9 and 11)
3	Short-circuit withstand strength	8.2.3	Verification of the short-circuit withstand strength by test (type test)	Verification of the short-circuit withstand strength by test or by extrapolation from similar type-tested arrangements
4	Effectiveness of the protective circuit	8.2.4		
	Effective connection between the exposed conductive parts of the ASSEMBLY and the protective circuit	8.2.4.1	Verification of the effective connection between the exposed conductive parts of the ASSEMBLY and the protective circuit	Verification of the effective connection between the exposed conductive parts of the ASSEMBLY and the protective circuit
	Short-circuit withstand strength of the protective circuit	8.2.4.2	Verification of the short-circuit withstand strength of the protective circuit by test (type test)	Verification of the short-circuit withstand strength of the protective circuit by test or appropriate design and arrangement of the protective conductor (see 7.4.3.1.1, last paragraph)
5	Clearances and creepage distances	8.2.5	Verification of the clearances and creepage distances (type test)	Verification of clearances and creepage distances
6	Mechanical operation	8.2.6	Verification of mechanical operation (type test)	Verification of mechanical operation
7	Degree of protection	8.2.7	Verification of the degree of protection (type test)	Verification of the degree of protection
8	Wiring, electrical operation	8.3.1	Inspection of the ASSEMBLY including inspection of wiring and, if necessary, electrical operation test (routine test)	Inspection of the ASSEMBLY including inspection of wiring and, if necessary, electrical operation test
9	Insulation	8.3.2	Dielectric test (routine test)	Dielectric test or verification of insulation resistance according to 8.3.4 (see Nos. 2 and 11)
10	Protective measures	8.3.3	Checking of protective measures and of the electrical continuity of the protective circuits (routine test)	Checking of protective measures
11	Insulation resistance	8.3.4		Verification of insulation resistance unless test according to 8.2.2 or 8.3.2 has been made (see Nos. 2 and 9)

The verification of temperature-rise limits for PTТА shall either be made

- by test in accordance with 8.2.1, or
- by extrapolation, for example in accordance with IEC 60890.

8.2.1.2 Arrangement of the ASSEMBLY

The ASSEMBLY shall be arranged as in normal use, with all covers, etc., in place.

When testing individual parts or constructional units, the adjoining parts or constructional units shall produce the same temperature conditions as in normal use. Heating resistors may be used.

8.2.1.3 Temperature-rise test using current on all apparatus

The test shall be made on one or more representative combinations of circuits for which the ASSEMBLY is designed so chosen as to obtain with reasonable accuracy the highest possible temperature rise.

For this test, the incoming circuit is loaded to its rated current (see 4.2) and each outgoing circuit is loaded with its rated current multiplied by the rated diversity factor (see 4.7). If the ASSEMBLY includes fuses, these shall be fitted for the test with fuse-links as specified by the manufacturer. The power losses of the fuse-links used for the test shall be stated in the test report.

The size and the disposition of external conductors used for the test shall be stated in the test report.

The test shall be made for a time sufficient for the temperature rise to reach a constant value (normally not exceeding 8 h). In practice, this condition is reached when the variation does not exceed 1 K/h.

NOTE 1 To shorten the test, if the devices allow it, the current may be increased during the first part of the test, it being reduced to the specified rated current afterwards.

NOTE 2 When a control electro-magnet is energized during the test, the temperature is measured when thermal equilibrium is reached in both the main circuit and the control electro-magnet.

NOTE 3 In all cases, the use of single-phase a.c. current for testing multi-phase ASSEMBLIES is only permissible if magnetic effects are small enough to be neglected. This requires careful consideration especially for currents above 400 A.

In the absence of detailed information concerning the external conductors and the service conditions, the cross-section of the external test conductors shall be chosen, considering the rated current of each circuit as follows:

8.2.1.3.1 For values of rated current up to and including 400 A:

- a) the conductors shall be single-core, copper cables or insulated wires with cross-sectional areas as given in table 8;
- b) as far as practicable, the conductors shall be in free air;
- c) the minimum length of each temporary connection from terminal to terminal shall be:
 - 1 m for cross-sections up to and including 35 mm²;
 - 2 m for cross-sections larger than 35 mm².

Table 8 – Test copper conductors for rated currents up to 400 A inclusive

Range of rated current ¹⁾		Conductor cross-sectional area ^{2), 3)}	
		mm ²	AWG/MCM
0	8	1,0	18
8	12	1,5	16
12	15	2,5	14
15	20	2,5	12
20	25	4,0	10
25	32	6,0	10
32	50	10	8
50	65	16	6
65	85	25	4
85	100	35	3
100	115	35	2
115	130	50	1
130	150	50	0
150	175	70	00
175	200	95	000
200	225	95	0000
225	250	120	250
250	275	150	300
275	300	185	350
300	350	185	400
350	400	240	500

¹⁾ The value of the rated current shall be greater than the first value in the first column and less than or equal to the second value in that column.

²⁾ For convenience of testing and with the manufacturer's consent, smaller conductors than those given for a stated rated current may be used.

³⁾ Either of the two conductors specified for a given rated current range may be used.

8.2.1.3.2 For values of rated current higher than 400 A but not exceeding 800 A:

- a) The conductors shall be single-core, PVC insulated, copper cables with cross-sectional areas as given in table 9, or the equivalent copper bars given in table 9 as specified by the manufacturer.
- b) Cables or copper bars shall be spaced at approximately the distance between terminals. Copper bars shall be finished matt black. Multiple parallel cables per terminal shall be bunched together and arranged with approximately 10 mm air space between each other. Multiple copper bars per terminal shall be spaced at a distance approximately equal to the bar thickness. If the sizes stated for the bars are not suitable for the terminals or are not available, it is allowed to use other bars having approximately the same cross-sections and approximately the same or smaller cooling surfaces. Cables or copper bars shall not be interleaved.
- c) For single-phase or multi-phase tests, the minimum length of any temporary connection to the test supply shall be 2 m. The minimum length to a star point may be reduced to 1,2 m.

8.2.1.3.3 For values of rated current higher than 800 A but not exceeding 3 150 A:

- a) The conductors shall be copper bars of the sizes stated in table 9 unless the ASSEMBLY is designed only for cable connection. In this case, the size and arrangement of the cables shall be as specified by the manufacturer.
- b) Copper bars shall be spaced at approximately the distance between terminals. Copper bars shall be finished matt black. Multiple copper bars per terminal shall be spaced at a distance approximately equal to the bar thickness. If the sizes stated for the bars are not suitable for the terminals or are not available, it is allowed to use other bars having approximately the same cross-sections and approximately the same or smaller cooling surfaces. Copper bars shall not be interleaved.
- c) For single-phase or multi-phase tests, the minimum length of any temporary connection to the test supply shall be 3 m, but this can be reduced to 2 m provided that the temperature rise at the supply end of the connection is not more than 5 K below the temperature rise in the middle of the connection length. The minimum length to a star point shall be 2 m.

Table 9 – Standard cross-sections of copper conductors corresponding to the rated current

Values of the rated current A	Range of rated current ¹⁾ A	Test conductors			
		Cables		Copper bars ²⁾	
		Quantity	Cross sectional area ³⁾ mm ²	Quantity	Dimensions ³⁾ mm
500	400 to 500	2	150(16)	2	30 × 5(15)
630	500 to 630	2	185(18)	2	40 × 5(15)
800	630 to 800	2	240(21)	2	50 × 5(17)
1 000	800 to 1 000			2	60 × 5(19)
1 250	1 000 to 1 250			2	80 × 5(20)
1 600	1 250 to 1 600			2	100 × 5(23)
2 000	1 600 to 2 000			3	100 × 5(20)
2 500	2 000 to 2 500			4	100 × 5(21)
3 150	2 500 to 3 150			3	100 × 10(23)

1) The value of the current shall be greater than the first value and less than or equal to the second value.

2) Bars are assumed to be arranged with their long faces vertical. Arrangements with long faces horizontal may be used if specified by the manufacturer.

3) Values in brackets are estimated temperature rises (in kelvins) of the test conductors given for reference.

8.2.1.3.4 For values of rated current higher than 3 150 A:

An agreement shall be reached between manufacturer and user on all relevant items of the test, such as type of supply, number of phases and frequency (where applicable), cross-sections of test conductors, etc. This information shall form part of the test report.

8.2.1.4 Temperature-rise test using heating resistors with an equivalent power loss

For certain types of enclosed ASSEMBLIES with main and auxiliary circuits having comparatively low-rated currents, the power loss may be simulated by means of heating resistors which produce the same amount of heat and are installed in suitable places inside the enclosure.

The cross-section of the leads to these resistors shall be such that no appreciable amount of heat is conducted away from the enclosure.

This test with heating resistors is considered to be reasonably representative of all ASSEMBLIES using the same enclosure, even if they are equipped with different apparatus, provided that the sum of the power losses of the built-in apparatus, taking into account the diversity factor, does not exceed the value applied in the test.

The temperature rise of the built-in apparatus shall not exceed the values given in table 2 (see 7.3). This temperature rise can be approximately calculated by taking the temperature rise of this apparatus, measured in the open air, increased by the difference between the temperature inside the enclosure and the temperature of the air surrounding the enclosure.

8.2.1.5 Measurement of temperatures

Thermocouples or thermometers shall be used for temperature measurements. For windings, the method of measuring the temperature by resistance variation shall generally be used. For measuring the temperature of the air inside an ASSEMBLY, several measuring devices shall be arranged in convenient places.

The thermometers or thermocouples shall be protected against air currents and heat radiation.

8.2.1.6 Ambient air temperature

The ambient air temperature shall be measured during the last quarter of the test period by means of at least two thermometers or thermocouples equally distributed around the ASSEMBLY at about half its height and at a distance of about 1 m from the ASSEMBLY. The thermometers or thermocouples shall be protected against air currents and heat radiations.

If the ambient temperature during the test is between +10 °C and +40 °C, the values of table 2 are the limiting values of the temperature rise.

If the ambient air temperature during the test exceeds +40 °C or is lower than +10 °C, this standard does not apply, and the manufacturer and the user shall make a special agreement.

8.2.1.7 Results to be obtained

At the end of the test, the temperature rise shall not exceed the values specified in table 2. The apparatus shall operate satisfactorily within the voltage limits specified for them at the temperature inside the ASSEMBLY.

8.2.2 Verification of dielectric properties

8.2.2.1 General

This type test need not be made on such parts of the ASSEMBLY which have already been type-tested according to their relevant specifications provided their dielectric strength is not impaired by their mounting.

Furthermore, this test need not be made on PTTA (see table 7).

When the ASSEMBLY includes a protective conductor insulated from the exposed conductive parts according to item d) of 7.4.3.2.2, this conductor shall be regarded as a separate circuit, i.e. it shall be tested with the same voltage as the main circuit to which it belongs.

Tests shall be made:

- in accordance with 8.2.2.6.1 to 8.2.2.6.4 if the manufacturer has declared a value of the rated impulse withstand voltage U_{imp} (see 4.1.3);
- in accordance with 8.2.2.2 to 8.2.2.5, in the other cases.

8.2.2.2 Testing of enclosures made of insulating material

For enclosures made of insulating material, an additional dielectric test shall be carried out by applying a test voltage between a metal foil laid on the outside of the enclosure over openings and joints, and the interconnected live and exposed conductive parts within the enclosure located next to the openings and joints. For this additional test, the test voltage shall be equal to 1,5 times the values indicated in table 10.

NOTE Test voltages for enclosures for ASSEMBLIES protected by total insulation are under consideration.

8.2.2.3 External operating handles of insulating material

In the case of handles made of or covered by insulating material for the purpose of complying with 7.4.3.1.3, a dielectric test shall be carried out by applying a test voltage equal to 1,5 times the test voltage indicated in table 10 between the live parts and a metal foil wrapped round the whole surface of the handle. During this test, the frame must not be earthed or connected to any other circuit.

8.2.2.4 Application and value of the test voltage

The test voltage shall be applied

- 1) between all live parts and the interconnected exposed conductive parts of the ASSEMBLY;
- 2) between each pole and all the other poles connected for this test to the interconnected exposed conductive parts of the ASSEMBLY.

The test voltage at the moment of application shall not exceed 50 % of the values given in this subclause. It shall then be increased steadily within a few seconds to its full value specified in this subclause and maintained for 5 s. The a.c. power sources shall have sufficient power to maintain the test voltage irrespective of any leakage currents. The test voltage shall have a practically sinusoidal waveform and a frequency between 45 Hz and 62 Hz.

The value of the test voltage shall be as follows.

8.2.2.4.1 For the main circuit and for the auxiliary circuits which are not covered by 8.2.2.4.2 below, the value shall be in accordance with table 10.

Table 10

Rated insulation voltage U_i (line to line) V	Dielectric test voltage a.c. r.m.s. V
$U_i \leq 60$	1 000
$60 < U_i \leq 300$	2 000
$300 < U_i \leq 690$	2 500
$690 < U_i \leq 800$	3 000
$800 < U_i \leq 1\,000$	3 500
$1\,000 < U_i \leq 1\,500$ *	3 500
* For d.c. only.	

8.2.2.4.2 For auxiliary circuits which are indicated by the manufacturer as unsuitable for being directly supplied from the main circuit, the value shall be in accordance with table 11.

Table 11

Rated insulation voltage U_i (line to line) V	Dielectric test voltage a.c. r.m.s. V
$U_i \leq 12$	250
$12 < U_i \leq 60$	500
$60 < U_i$	$2 U_i + 1\,000$ with a minimum of 1 500

8.2.2.5 Results to be obtained

The test is considered to have been passed if there is no puncture or flash-over.

8.2.2.6 Impulse voltage withstand test

8.2.2.6.1 General conditions

The ASSEMBLY to be tested shall be mounted complete on its own support or an equivalent support as in normal service in accordance with the manufacturer's instructions and the ambient conditions stated in 6.1.

Any actuator of insulating material and any integral non-metallic enclosure of equipment intended to be used without additional enclosure shall be covered by a metal foil connected to the frame or the mounting plate. The foil shall be applied to all surfaces where they can be touched with the standard test finger (test probe B of IEC 60529).

8.2.2.6.2 Test voltages

The test voltage shall be that specified in 7.1.2.3.2 and 7.1.2.3.3.

With the manufacturer's agreement, the test may be done using power frequency or d.c. voltage as given in table 13. Disconnection of surge arresters during this test is permitted, provided that the characteristics of the surge arresters are known. However, equipment incorporating overvoltage suppressing means shall preferably be tested with impulse voltage. The energy contents of the test current shall not exceed the energy rating of the overvoltage suppressing means.

NOTE The ratings of the suppressing means should be suitable for the application. Such ratings are under consideration.

- a) The 1,2/50 μ s impulse voltage shall be applied three times for each polarity at intervals of 1 s minimum.
- b) Power frequency and d.c. voltage shall be applied during three cycles in the case of a.c. or 10 ms for each polarity, in the case of d.c.

Clearances equal to or larger than the values of case A of table 14 may be verified by measurement, according to the method described in annex F.

8.2.2.6.3 Application of test voltages

The test voltage is applied as follows:

- a) between each live part (including the control and auxiliary circuits connected to the main circuit) and the interconnected exposed conductive parts of the ASSEMBLY;
- b) between each pole of the main circuit and the other poles;
- c) between each control and auxiliary circuit not normally connected to the main circuit(s) and
 - the main circuit,
 - the other circuits,
 - the exposed conductive parts,
 - the enclosure or mounting plate;
- d) for withdrawable parts in the isolated position: across the isolating gaps, between the supply side and the withdrawable part, and between the supply terminal and load terminal, as relevant.

8.2.2.6.4 Results to be obtained

There shall be no unintentional disruptive discharge during the tests.

NOTE 1 An exception is an intentional disruptive discharge designed for the purpose, for example transient overvoltage suppressing means.

NOTE 2 The term "disruptive discharge" relates to phenomena associated with the failure of insulation under electrical stress, in which the discharge completely bridges the insulation under test, reducing the voltage between the electrodes to zero or nearly zero.

NOTE 3 The term "sparkover" is used when a disruptive discharge occurs in a gaseous or liquid dielectric.

NOTE 4 The term "flashover" is used when a disruptive discharge occurs over the surface of a dielectric in a gaseous or liquid medium.

NOTE 5 The term "puncture" is used when a disruptive discharge occurs through a solid dielectric.

NOTE 6 A disruptive discharge in a solid dielectric produces permanent loss of dielectric strength; in a liquid or gaseous dielectric, the loss may be only temporary.

8.2.2.7 Verification of creepage distances

The shortest creepage distances between phases, between circuit conductors at different voltages, and between live and exposed conductive parts shall be measured. The measured creepage distance with respect to material group and pollution degree shall comply with the requirements of 7.1.2.3.5.

8.2.3 Verification of short-circuit withstand strength

8.2.3.1 Circuits of ASSEMBLIES which are exempted from the verification of the short-circuit withstand strength

A verification of the short-circuit withstand strength is not required in the following cases.

8.2.3.1.1 For ASSEMBLIES having a rated short-time current or rated conditional short-circuit current not exceeding 10 kA.

8.2.3.1.2 For ASSEMBLIES protected by current-limiting devices having a cut-off current not exceeding 17 kA at the maximum allowable prospective short-circuit current at the terminals of the incoming circuit of the ASSEMBLY.

8.2.3.1.3 For auxiliary circuits of ASSEMBLIES intended to be connected to transformers whose rated power does not exceed 10 kVA for a rated secondary voltage of not less than 110 V, or 1,6 kVA for a rated secondary voltage less than 110 V, and whose short-circuit impedance is not less than 4 %.

8.2.3.1.4 For all parts of ASSEMBLIES (busbars, busbar supports, connections to busbars, incoming and outgoing units, switching devices, etc.) which have already been subjected to type tests valid for conditions in the ASSEMBLY.

NOTE Examples of switching devices are devices with a rated conditional short-circuit current according to IEC 60947-3 or motor-starters co-ordinated with short-circuit protective devices according to IEC 60947-4-1.

8.2.3.2 Circuits of ASSEMBLIES the short-circuit withstand strength of which shall be verified

This subclause applies to all circuits not mentioned in 8.2.3.1.

8.2.3.2.1 Test arrangements

The ASSEMBLY or its parts shall be set up as in normal use. Except for tests on the busbars and depending on the type of construction of the ASSEMBLY, it will be sufficient to test a single functional unit if the remaining functional units are constructed in the same way and cannot affect the test result.

8.2.3.2.2 Performance of the test – General

If the test circuit incorporates fuses, fuse-links of the maximum current rating (corresponding to the rated current) and, if required, of the type indicated by the manufacturer as being acceptable, shall be used.

The supply conductors and the short-circuit connections required for testing the ASSEMBLY shall have sufficient strength to withstand short circuits and be so arranged that they do not introduce any additional stresses.

Unless otherwise agreed, the test circuit shall be connected to the input terminals of the ASSEMBLY. Three-phase ASSEMBLIES shall be connected on a three-phase basis.

For the verification of all the short-circuit withstand ratings (see 4.3, 4.4, 4.5 and 4.6), the value of the prospective short-circuit current at a supply voltage equal to 1,05 times the rated operational voltage shall be determined from a calibration oscillogram which is taken with the supply conductors to the ASSEMBLY short-circuited by a connection of negligible impedance placed as near as possible to the input supply of the ASSEMBLY. The oscillogram shall show that there is a constant flow of current such that it is measurable at a time equivalent to the operation of the protective device incorporated in the ASSEMBLY or for a specified period of time, this current approximating the value specified in 8.2.3.2.4.

For a.c. tests, the frequency of the test circuit during the short-circuit tests shall be that of the rated frequency subject to a tolerance of 25 %.

All parts of the equipment intended to be connected to the protective conductor in service, including the enclosure, shall be connected as follows:

- 1) for ASSEMBLIES suitable for use on three-phase four-wire systems (see also IEC 60038) with an earthed star point and marked accordingly, to the neutral point of supply or to a substantially inductive artificial neutral permitting a prospective fault current of at least 1 500 A;
- 2) for ASSEMBLIES also suitable for use in three-phase three-wire as well as on three-phase four-wire systems and marked accordingly, to the phase conductor least likely to arc to earth.

NOTE Marking and designation methods are under consideration.

Except for ASSEMBLIES according to 7.4.3.2.2, the test circuit shall include a reliable device (e.g. a fuse of copper wire of 0,8 mm diameter and not less than 50 mm in length) for the detection of the fault current. The prospective fault current in the fusible element circuit shall be 1 500 A \pm 10 %, except as stated in notes 2 and 3. If necessary, a resistor limiting the current to that value shall be used.

NOTE 1 A copper wire of 0,8 mm diameter will melt at 1 500 A, in approximately half a cycle, at a frequency between 45 Hz and 67 Hz (or 0,01 s for d.c.).

NOTE 2 The prospective fault current may be less than 1 500 A in the case of small equipment, according to the requirements of the relevant product standard, with a smaller diameter copper wire (see note 4) corresponding to the same melting time as in note 1.

NOTE 3 In the case of a supply having an artificial neutral, a lower prospective fault current may be accepted, subject to the agreement of the manufacturer, with a smaller diameter copper wire (see note 4) corresponding to the same melting time as in note 1.

NOTE 4 The relationship between the prospective fault current in the fusible element circuit and the diameter of the copper wire should be in accordance with table 12.

Table 12 – Relationship between prospective fault current and diameter of copper wire

Diameter of copper wire mm	Prospective fault current in the fusible element circuit A
0,1	50
0,2	150
0,3	300
0,4	500
0,5	800
0,8	1 500

8.2.3.2.3 Testing of the main circuits

For ASSEMBLIES with busbars, the tests according to items a), b) and d) below apply.

For ASSEMBLIES without busbars, the test according to item a) applies.

For ASSEMBLIES where the requirements of 7.5.5.1.2 are not fulfilled, the test according to item c) applies in addition.

- a) Where an outgoing circuit includes a component which has not previously been subjected to the appropriate test, the following test shall apply.

For testing an outgoing circuit, the associated outgoing terminals shall be provided with a bolted short-circuit connection. When the protective device in the outgoing circuit is a circuit-breaker, the test circuit may include a shunting resistor in accordance with 8.3.4.1.2 b) of IEC 60947-1 in parallel with the reactor used to adjust the short-circuit current.

For circuit-breakers having a rated current up to and including 630 A, a cable 0,75 m in length having a cross-sectional area corresponding to the conventional thermal current (see IEC 60947-1, tables 9 and 10) shall be included in the test circuit. The switching device shall be closed and held closed in the manner normally used in service. The test voltage shall then be applied once and for a time sufficiently long to enable the short-circuit protective device in the outgoing unit to operate to clear the fault and, in any case, for not less than 10 cycles (test voltage duration).

- b) ASSEMBLIES containing main busbars shall be subjected to one additional test to prove the short-circuit withstand strength of the main busbars and the incoming circuit including any joints. The point where the short-circuit is produced shall be $2 \text{ m} \pm 0,40 \text{ m}$ distant from the nearest point of supply. For the verification of rated short time current (see 4.3) and rated peak withstand current (see 4.4), this distance may be increased if the tests are conducted at lower voltage providing the test current is the rated value (see item b) of 8.2.3.2.4). Where the design of the ASSEMBLY is such that the length of the busbars to be tested is less than 1,6 m and the ASSEMBLY is not intended to be extended, then the complete length of busbar shall be tested, the short-circuit being established at the end of these busbars. If a set of busbars consists of different sections (as regards cross-sections, distance between adjacent busbars, type and number of supports per meter), each section shall be tested separately. The test may be conducted concurrently, provided that the above conditions are met.
- c) A short circuit is obtained by bolted connections on the conductors connecting the busbars to a single outgoing unit, as near as practicable to the terminals on the busbar side of the outgoing unit. The value of the short-circuit current shall be the same as that for the main bars.
- d) If a neutral bar exists, it shall be subjected to one test to prove its short-circuit withstand strength in relation to the nearest phase busbar including any joints. For the connection of the neutral bar to this phase busbar, the requirements of item b) of 8.2.3.2.3 apply. Unless otherwise agreed between manufacturer and user, the value of the test current in the neutral bar shall be 60 % of the phase current during the three-phase test.

8.2.3.2.4 Value and duration of the short-circuit current

- a) For ASSEMBLIES protected by short-circuit protective devices, whether these devices are in the incoming circuit or elsewhere, the test voltage shall be applied for a time sufficiently long to enable the short-circuit protective devices to operate to clear the fault and, in any case, for not less than 10 cycles.

- b) ASSEMBLIES which do not incorporate a short-circuit protective device in the incoming unit (see 7.5.2.1.2).

For all short-circuit withstand ratings, the dynamic and thermal stresses shall be verified with a prospective current, at the supply side of the specified protective device, if any, equal to the value of the rated short-time current, rated peak withstand current, rated conditional short-circuit current or rated fused short-circuit current assigned by the manufacturer.

In the case of test station difficulty of making the short-time or peak withstand tests at the maximum operational voltage, the tests according to items b), c) and d) of 8.2.3.2.3 may be made at any convenient lower voltage, the actual test current being, in this case, equal to the rated short-time current or peak withstand current. This shall be stated in the test report. If, however, momentary contact separation occurs in the protective device, if any, during the test, the test shall be repeated at the maximum operational voltage.

For the short-time and peak current withstand tests, any overcurrent release, if any, likely to operate during the test shall be rendered inoperative.

All tests shall be made at the rated frequency of the equipment with a tolerance of $\pm 25\%$, and at the power factor appropriate to the short-circuit current in accordance with table 4.

The value of current during the calibration is the average of the r.m.s. values of the a.c. component in all phases. When making the tests at maximum operational voltage, the calibration current is the actual test current. In each phase, the current shall be within the tolerance $+5\%$ and 0% , and the power factor within the tolerance between $+0,0$ and $-0,05$. The current shall be applied for the specified time during which the r.m.s. value of its a.c. component shall remain constant.

NOTE 1 However, if necessary, due to test limitations, a different test period is permissible; in such a case, the test current should be modified in accordance with the formula $I^2t = \text{constant}$, provided that the peak value does not exceed the rated peak withstand current without the manufacturer's consent and that the r.m.s. value of the short-time current is not less than the rated value in at least one phase for at least 0,1 s after current initiation.

NOTE 2 The peak current withstand test and the short-time current test may be separated. In this case, the time during which the short circuit is applied for the peak current withstand test should be such that the value I^2t is not larger than the equivalent value for the short-time current test, but it should be not less than three cycles.

NOTE 3 Where the required test current in each phase cannot be achieved, the positive test tolerance may be exceeded with the agreement of the manufacturer.

For the conditional and fused short-circuit current test, the test shall be conducted at 1,05 times the rated operational voltage (see 8.2.3.2.2) with prospective currents, at the supply side of the specified protective device, equal to the value of the rated conditional or fused short-circuit current. Tests at lower voltages are not permitted.

8.2.3.2.5 Results to be obtained

After the test, the conductors shall not show any undue deformation. A slight deformation of busbars is acceptable provided that the clearances and creepage distances specified in 7.1.2 are still complied with. Also, the insulation of the conductors and the supporting insulating parts shall not show any significant signs of deterioration, that is, the essential characteristics of the insulation shall remain such that the mechanical and dielectric properties of the equipment satisfy the requirements of this standard.

The detection device, if any, shall not indicate a fault current.

There shall be no loosening of parts used for the connection of conductors and the conductors shall not separate from the outgoing terminals.

Deformation of the enclosure is permissible to the extent that the degree of protection is not impaired and the clearances are not reduced to values which are less than those specified.

Any distortion of the busbar circuit or the frame of the ASSEMBLY which impairs normal insertion of withdrawable or removable units shall be deemed a failure.

In case of doubt, it shall be checked that the apparatus incorporated in the ASSEMBLY are in a condition as prescribed in the relevant specifications.

Additionally after the test of 8.2.3.2.3 a) and tests incorporating short-circuit protective devices, the tested equipment shall be capable of withstanding the dielectric test of 8.2.2, at a value of voltage for the after test condition prescribed in the relevant standard for the appropriate short-circuit test, as follows:

- a) between all live parts and the frame of the ASSEMBLY, and
- b) between each pole and all other poles connected to the frame of the ASSEMBLY.

If tests a) and b) above are conducted, they shall be carried out with any fuses replaced and with any switching device closed.

8.2.3.2.6 For PTTA, the verification of short-circuit withstand strength shall be made:

- either by test in accordance with 8.2.3.2.1 to 8.2.3.2.5;
- or by extrapolation from similar type-tested arrangements.

NOTE 1 An example of a method of extrapolation from type-tested arrangements is given in IEC 61117.

NOTE 2 Care should be taken to compare the conductor strength, distance between live parts and exposed conductive parts, distance between supports, height and strength of supports, and strength and type of support locating structure.

8.2.4 Verification of the effectiveness of the protective circuit

8.2.4.1 Verification of the effective connection between the exposed conductive parts of the ASSEMBLY and the protective circuit

It shall be verified that the different exposed conductive parts of the ASSEMBLY are effectively connected to the protective circuit and their resistance between the incoming protective conductor and the relevant exposed conductive part does not exceed 0,1 Ω .

Verification shall be made employing a resistance measuring instrument or arrangement which is capable of driving a current of at least 10 A a.c. or d.c. into an impedance of 0,1 Ω between the points of the resistance measurement.

NOTE It may be necessary to limit the duration of the test to 5 s where low-current equipment otherwise may be adversely affected by the test.

8.2.4.2 Verification of the short-circuit strength of the protective circuit by test (does not apply for circuits according to 8.2.3.1)

A single-phase test supply shall be connected to the incoming terminal of one phase and to the terminal for the incoming protective conductor. When the ASSEMBLY is provided with a separate protective conductor, the nearest phase conductor shall be used. For each

representative outgoing unit, a separate test shall be made with a bolted short-circuit connection between the corresponding outgoing phase terminal of the unit and the terminal for the relevant outgoing protective conductor.

Each outgoing unit on test shall be provided with that protective device among those intended for the unit which lets through the maximum values of peak current and I^2t . The test may be made with the protective device located outside the ASSEMBLY.

For this test, the frame of the ASSEMBLY shall be insulated from earth. The test voltage shall be equal to the single-phase value of the rated operational voltage. The value of the prospective short-circuit current used shall be 60 % of the value of the prospective short-circuit current of the three-phase short-circuit withstand test of the ASSEMBLY.

All other conditions of this test shall be analogous to 8.2.3.2.

8.2.4.3 Results to be obtained

The continuity and the short-circuit withstand strength of the protective circuit, whether it consists of a separate conductor or the frame, shall not be significantly impaired.

Besides visual inspection, this may be verified by measurements with a current in the order of the rated current of the relevant outgoing unit.

NOTE 1 Where the frame is used as a protective conductor, sparks and localized heating at joints are permitted, provided they do not impair the electrical continuity and provided that adjacent flammable parts are not ignited.

NOTE 2 A comparison of the resistances, measured before and after the test, between the terminal for the incoming protective conductor and the terminal for the relevant outgoing protective conductor gives an indication of conformity with this condition.

8.2.5 Verification of clearances and creepage distances

It shall be verified that the clearances and creepage distances comply with the values specified in 7.1.2.

If the ASSEMBLY contains withdrawable parts, it is necessary to verify that both in the test position (see 2.2.9), if any, and in the isolated position (see 2.2.10), the clearances and creepage distances are complied with.

8.2.6 Verification of mechanical operation

This type test shall not be made on such devices of the ASSEMBLY which have already been type tested according to their relevant specifications provided their mechanical operation is not impaired by their mounting.

For those parts which need a type test, satisfactory mechanical operation shall be verified after installation in the ASSEMBLY. The number of operating cycles shall be 50.

NOTE In the case of withdrawable functional units, the cycle covers any physical movements from the connected to the isolated position and back to the connected position.

At the same time, the operation of the mechanical interlocks associated with these movements shall be checked. The test is considered to have been passed if the operating conditions of the apparatus, interlocks, etc., have not been impaired and if the effort required for operation is practically the same as before the test.

8.2.7 Verification of degree of protection

The degree of protection provided in accordance with 7.2.1 and 7.7 shall be verified in accordance with IEC 60529, making, where necessary, adaptations to suit the particular type of the ASSEMBLY. If traces of water are readily observable within the enclosure immediately after the test for water ingress, then the dielectric properties shall be verified by test in accordance with 8.2.2. The test device for IP3X and IP4X as well as the type of support for the enclosure during the IP4X test shall be stated in the test report.

ASSEMBLIES having a degree of protection of IP5X shall be tested according to category 2 in 13.4 of IEC 60529.

ASSEMBLIES having a degree of protection of IP6X shall be tested according to category 1 in 13.4 of IEC 60529.

8.2.8 EMC tests

For EMC tests see H.8.2.8.

8.2.8.1 Immunity tests

The immunity has to be verified by the following tests:

Type of test	Test level required ¹⁾
1,2/50 μ s - 8/20 μ s surges IEC 61000-4-5	2 kV (line to earth) 1 kV (line to line)
Fast transient bursts IEC 61000-4-4	2 kV
Electromagnetic field IEC 61000-4-3	10 V/m
Electrostatic discharges IEC 61000-4-2	8 kV/air discharge

8.2.8.2 Emission tests

The emission limits shall be verified in accordance with the following standards:

- CISPR 11 class B for environment 1
- CISPR 11 class A for environment 2

8.2.9 Verification of the resistance of insulating materials to abnormal heat and fire (glow-wire test)

The glow-wire test shall be carried out according to IEC 60695-2-10 and IEC 60695-2-11, under the conditions specified in 7.1.4:

- a) on complete parts of the ASSEMBLY or,
- b) on parts taken from these parts, or
- c) on samples made of identical material and having a representative thickness.

¹⁾ This corresponds to level 3 in IEC 61000-4.

8.3 Routine tests

8.3.1 Inspection of the ASSEMBLY including inspection of wiring and, if necessary, electrical operation test

The effectiveness of mechanical actuating elements, interlocks, locks, etc., shall be checked. The conductors and cables shall be checked for proper laying and the devices for proper mounting. A visual inspection is also necessary to ensure that the prescribed degree of protection, creepage distances and clearances are maintained.

The connections, especially screwed and bolted connections, shall be checked for adequate contact, possibly by random tests.

Furthermore, it shall be verified that the information and markings specified in 5.1 and 5.2 are complete, and that the ASSEMBLY corresponds to these. In addition, the conformity of the ASSEMBLY to the circuit and wiring diagrams, technical data, etc., provided by the manufacturer shall be checked.

Depending on the complexity of the ASSEMBLY, it may be necessary to inspect the wiring and to carry out an electrical functioning test. The test procedure and the number of tests depend on whether or not the ASSEMBLY includes complicated interlocks, sequence control facilities, etc.

In some cases, it may be necessary to make or repeat this test on site when putting the installation for which the ASSEMBLY is intended into operation. In this case, a special agreement shall be made between manufacturer and user.

8.3.2 Dielectric test

Tests shall be made

- in accordance with 8.3.2.1 and item b) of 8.3.2.2, if the manufacturer has declared a value of the rated impulse withstand voltage U_{imp} (see 4.1.3);
- in accordance with 8.3.2.1 and item a) of 8.3.2.2, in the other cases.

These tests need not be made on PTTA whose insulation resistance has been verified in accordance with 8.2.2.1 or 8.3.4.

This test need not be made either on auxiliary circuits of TTA and PTTA which are protected by a short-circuit protective device with a rating not exceeding 16 A and if, previously, an electrical function test (see 8.3.1) has been made at the rated voltage for which the auxiliary circuits are designed.

8.3.2.1 General

All electrical equipment of the ASSEMBLY shall be connected for the test, except those apparatus which, according to the relevant specifications, are designed for a lower test voltage; current-consuming apparatus (e.g. windings, measuring instruments) in which the application of the test voltage would cause the flow of a current, shall be disconnected. These apparatus shall be disconnected at one of their terminals unless they are not designed to withstand the full test voltage, in which case all terminals may be disconnected.

Anti-interference capacitors installed between live and exposed conductive parts shall not be disconnected and shall be capable of withstanding the test voltage.

8.3.2.2 Application, duration and value of test voltage

- a) The test voltage according to 8.2.2.4 shall be applied for 1 s. The a.c. source shall have sufficient power to maintain the test voltage irrespective of all leakage currents. The test voltage shall have a practically sinusoidal waveform and a frequency between 45 Hz and 62 Hz.

If the equipment included in the main or auxiliary circuits to be tested has previously been subjected to a dielectric test, the test voltage shall be reduced to 85 % of the value indicated in 8.2.2.4.

For the test:

- either all switching devices shall be closed, or
- the test voltage shall be supplied successively to all parts of the circuit.

The test voltage shall be applied between the live parts and the conductive structural parts of the ASSEMBLY.

- b) The tests shall be made in accordance with 8.2.2.6.2 and 8.2.2.6.3. If, in a circuit, components are incorporated which, in accordance with their IEC standards are routine tested with lower test voltages, these lower voltages shall be used for the test. However, the test voltage shall be not less than 30 % of the rated impulse withstand voltage (without altitude correction factor) or twice the rated insulation voltage, whichever is the higher.

8.3.2.3 Results to be obtained

The test is considered to have been passed if there is no puncture or flashover.

8.3.3 Checking of protective measures and of the electrical continuity of the protective circuits

The protective measures with regard to protection against direct and indirect contact (see 7.4.2 and 7.4.3) shall be checked.

The protective circuits shall be checked by inspection to ascertain that the measures prescribed in 7.4.3.1.5 are complied with. In particular, screwed and bolted connections shall be checked for adequate contact, possibly by random tests.

8.3.4 Verification of insulation resistance

For PTTA which have not been subjected to a dielectric test according to 8.2.2 or 8.3.2, an insulation measurement using an insulation measuring device at a voltage of at least 500 V shall be carried out.

In this case, the test is deemed satisfactory if the insulation resistance between circuits and exposed conductive parts is at least 1 000 Ω/V per circuit referred to the nominal voltage to earth of these circuits.

By exception, items which, according to their specific requirements, are current-consuming apparatus (e.g. windings, measuring instruments) at the application of the test voltage or are not designed for the full test voltage shall be disconnected as appropriate.

Table 13 – Dielectric withstand voltages for impulse, power frequency and d.c. tests

Rated impulse withstand voltage U_{imp} kV	Test voltages and corresponding altitudes									
	$U_{1,2/50}$, a.c. peak and d.c. kV					AC r.m.s. kV				
	Sea level	200 m	500 m	1 000 m	2 000 m	Sea level	200 m	500 m	1 000 m	2 000 m
0,33	0,36	0,36	0,35	0,34	0,33	0,25	0,25	0,25	0,25	0,23
0,5	0,54	0,54	0,53	0,52	0,5	0,38	0,38	0,38	0,37	0,36
0,8	0,95	0,9	0,9	0,85	0,8	0,67	0,64	0,64	0,60	0,57
1,5	1,8	1,7	1,7	1,6	1,5	1,3	1,2	1,2	1,1	1,06
2,5	2,9	2,8	2,8	2,7	2,5	2,1	2,0	2,0	1,9	1,77
4	4,9	4,8	4,7	4,4	4	3,5	3,4	3,3	3,1	2,83
6	7,4	7,2	7	6,7	6	5,3	5,1	5,0	4,75	4,24
8	9,8	9,6	9,3	9	8	7,0	6,8	6,6	6,4	5,66
12	14,8	14,5	14	13,3	12	10,5	10,3	10,0	9,5	8,48

NOTE 1 This table uses the characteristics of a homogeneous field, case B (see 2.9.15), for which the impulse, d.c. and peak a.c. withstand voltage values are the same. The r.m.s. value is derived from the a.c. peak value.

NOTE 2 Where clearances are between case A and case B conditions, the a.c. and d.c. values of this table are more severe than the impulse voltage.

NOTE 3 Power frequency voltage testing is subject to the manufacturer's agreement (see 8.2.2.6.2).

Table 14 – Minimum clearances in air

Rated impulse withstand voltage U_{imp} kV	Minimum clearances mm							
	Case A Inhomogeneous field (see 2.9.16)				Case B Homogeneous field, ideal conditions (see 2.9.15)			
	Pollution degree				Pollution degree			
	1	2	3	4	1	2	3	4
0,33	0,01				0,01			
0,5	0,04	0,2			0,04	0,2		
0,8	0,1		0,8		0,1		0,8	1,6
1,5	0,5	0,5		1,6	0,3	0,3		
2,5	1,5	1,5	1,5		0,6	0,6		
4	3	3	3	3	1,2	1,2	1,2	
6	5,5	5,5	5,5	5,5	2	2	2	2
8	8	8	8	8	3	3	3	3
12	14	14	14	14	4,5	4,5	4,5	4,5

NOTE The values of minimum clearances in air are based on 1,2/50 μ s impulse voltages, for barometric pressure of 80 kPa equivalent to normal atmospheric pressure at 2 000 m above sea level.

Table 15 – Test voltages across the open contacts of equipment suitable for isolation

Rated impulse withstand voltage U_{imp} kV	Test voltages and corresponding altitudes									
	$U_{1,2/50}$, a.c. peak and d.c. kV					AC r.m.s. kV				
	Sea level	200 m	500 m	1 000 m	2 000 m	Sea level	200 m	500 m	1 000 m	2 000 m
0,33	1,8	1,7	1,7	1,6	1,5	1,3	1,2	1,2	1,1	1,06
0,5	1,8	1,7	1,7	1,6	1,5	1,3	1,2	1,2	1,1	1,06
0,8	1,8	1,7	1,7	1,6	1,5	1,3	1,2	1,2	1,1	1,06
1,5	2,3	2,3	2,2	2,2	2	1,6	1,6	1,55	1,55	1,42
2,5	3,5	3,5	3,4	3,2	3	2,47	2,47	2,4	2,26	2,12
4	6,2	6	5,8	5,6	5	4,38	4,24	4,10	3,96	3,54
6	9,8	9,6	9,3	9	8	7,0	6,8	6,60	6,40	5,66
8	12,3	12,1	11,7	11,1	10	8,7	8,55	8,27	7,85	7,07
12	18,5	18,1	17,5	16,7	15	13,1	12,80	12,37	11,80	10,6

NOTE 1 Where clearances are between case A and case B conditions (see table 14), the a.c. and d.c. values in this table are more severe than the impulse voltage.

NOTE 2 Power frequency voltage testing is subject to the manufacturer's agreement (see 8.2.2.6.2).

Table 16 – Minimum creepage distances

Rated insulation voltage of equipment or working voltage a.c. r.m.s. or d.c. V ⁵⁾	Creepage distances for equipment subject to long-term stress mm													
	Pollution degree 1 ⁶⁾			Pollution degree 2				Pollution degree 3				Pollution degree 4		
	2 ⁶⁾	1	Material group 2				Material group 3				Material group 4			
	2)	3)	2)	I ¹⁾	II	IIIa	IIIb	I	II	IIIa	IIIb	I	II	IIIa
10	0,025	0,04	0,08	0,4	0,4	0,4	1	1	1	1,6	1,6	1,6		
12,5	0,025	0,04	0,09	0,42	0,42	0,42	1,05	1,05	1,05	1,6	1,6	1,6		
16	0,025	0,04	0,1	0,45	0,45	0,45	1,1	1,1	1,1	1,6	1,6	1,6		
20	0,025	0,04	0,11	0,48	0,48	0,48	1,2	1,2	1,2	1,6	1,6	1,6		
25	0,025	0,04	0,125	0,5	0,5	0,5	1,25	1,25	1,25	1,7	1,7	1,7		
32	0,025	0,04	0,14	0,53	0,53	0,53	1,3	1,3	1,3	1,8	1,8	1,8		
40	0,025	0,04	0,16	0,56	0,8	1,1	1,4	1,6	1,8	1,9	2,4	3		
50	0,025	0,04	0,18	0,6	0,85	1,2	1,5	1,7	1,9	2	2,5	3,2		
63	0,04	0,063	0,2	0,63	0,9	1,25	1,6	1,8	2	2,1	2,6	3,4		
80	0,063	0,1	0,22	0,67	0,95	1,3	1,7	1,9	2,1	2,2	2,8	3,6		
100	0,1	0,16	0,25	0,71	1	1,4	1,8	2	2,2	2,4	3,0	3,8		
125	0,16	0,25	0,28	0,75	1,05	1,5	1,9	2,1	2,4	2,5	3,2	4		
160	0,25	0,4	0,32	0,8	1,1	1,6	2	2,2	2,5	3,2	4	5		
200	0,4	0,63	0,42	1	1,4	2	2,5	2,8	3,2	4	5	6,3		
250	0,56	1	0,56	1,25	1,8	2,5	3,2	3,6	4	5	6,3	8		
320	0,75	1,6	0,75	1,6	2,2	3,2	4	4,5	5	6,3	8	10	4)	
400	1	2	1	2	2,8	4	5	5,6	6,3	8	10	12,5		
500	1,3	2,5	1,3	2,5	3,6	5	6,3	7,1	8,0	10	12,5	16		
630	1,8	3,2	1,8	3,2	4,5	6,3	8	9	10	12,5	16	20		
800	2,4	4	2,4	4	5,6	8	10	11	12,5	16	20	25		
1 000	3,2	5	3,2	5	7,1	10	12,5	14	16	20	25	32		
1 250			4,2	6,3	9	12,5	16	18	20	25	32	40		
1 600			5,6	8	11	16	20	22	25	32	40	50		
2 000			7,5	10	14	20	25	28	32	40	50	63		
2 500			10	12,5	18	25	32	36	40	50	63	80		
3 200			12,5	16	22	32	40	45	50	63	80	100		
4 000			16	20	28	40	50	56	63	80	100	125		
5 000			20	25	36	50	63	71	80	100	125	160		
6 300			25	32	45	63	80	90	100	125	160	200		
8 000			32	40	56	80	100	110	125	160	200	250		
10 000			40	50	71	100	125	140	160	200	250	320		

1) Material group I or material groups II, IIIa, IIIb where likelihood of track is reduced due to the conditions of 2.4 of IEC 60664-1.

2) Material groups I, II, IIIa and IIIb.

3) Material groups I, II, IIIa.

4) Values of creepage distances in this area have not been established. Material group IIIb is in general not recommended for application in pollution degree 3 above 630 V and in pollution degree 4.

5) As an exception, for rated insulation voltages 127, 208, 415, 440, 660/690 and 830 V, creepage distances corresponding to the lower values 125, 200, 400, 630 and 800 V may be used.

6) The values given in these two columns apply to creepage distances of printed wiring materials.

NOTE 1 It is appreciated that tracking or erosion will not occur on insulation subjected to working voltages of 32 V and below. However, the possibility of electrolytic corrosion has to be considered and, for this reason, minimum creepage distances have been specified.

NOTE 2 Voltage values are selected in accordance with the R10 series.

Annex A (normative)

Minimum and maximum cross-sections of copper conductors suitable for connection (see 7.1.3.2)

The following table applies for the connection of one copper cable per terminal.

Table A.1

Rated current	Solid or stranded conductors		Flexible conductors	
	Cross-sections		Cross-sections	
	min.	max.	min.	max.
A	mm ²		mm ²	
6	0,75	1,5	0,5	1,5
8	1	2,5	0,75	2,5
10	1	2,5	0,75	2,5
12	1	2,5	0,75	2,5
16	1,5	4	1	4
20	1,5	6	1	4
25	2,5	6	1,5	4
32	2,5	10	1,5	6
40	4	16	2,5	10
63	6	25	6	16
80	10	35	10	25
100	16	50	16	35
125	25	70	25	50
160	35	95	35	70
200	50	120	50	95
250	70	150	70	120
315	95	240	95	185

NOTE 1 If the external conductors are connected directly to built-in apparatus, the cross-sections indicated in the relevant specifications are valid.

NOTE 2 In cases where it is necessary to provide for conductors other than those specified in the table, special agreement shall be reached between manufacturer and user.

Annex B (normative)

Method of calculating the cross-sectional area of protective conductors with regard to thermal stresses due to currents of short duration (more detailed information is to be found in IEC 60364-5-54)

The following formula shall be used to calculate the cross-section of the protective conductors necessary to withstand the thermal stresses due to currents with a duration of the order of 0,2 s to 5 s.

$$S_p = \frac{\sqrt{I^2 t}}{k}$$

where

S_p is the cross-sectional area, in square millimetres;

I is the value (r.m.s.) of a.c. fault current for a fault of negligible impedance which can flow through the protective device, in amperes;

t is the operating time of the disconnecting device, in seconds;

NOTE Account should be taken of the current-limiting effect of the circuit impedances and the limiting capability (Joule integral) of the protective device.

k is the factor dependent on the material of the protective conductor, the insulation and other parts and the initial and final temperatures.

Table B.1 – Values of k for insulated protective conductors not incorporated in cables, or bare protective conductors in contact with cable covering

	Insulation of protective conductor or cable covering		
	PVC	XLPE EPR Bare conductors	Butyl rubber
Final temperature	160 °C	250 °C	220 °C
	Factor k		
Material of conductor:			
Copper	143	176	166
Aluminium	95	116	110
Steel	52	64	60
NOTE The initial temperature of the conductor is assumed to be 30 °C.			

Annex C

(deleted)

Annex D
(informative)

Forms of internal separations
(see 7.7)

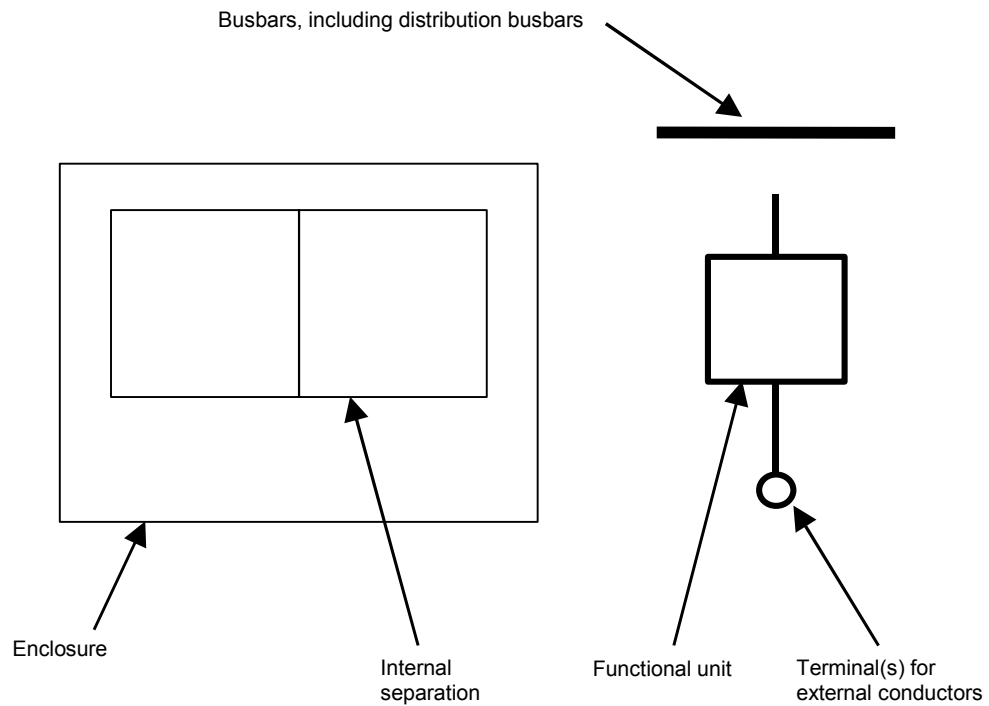

IEC 057/04

Figure D.1 – Symbols used in figures D.2

Form 1

No internal separation

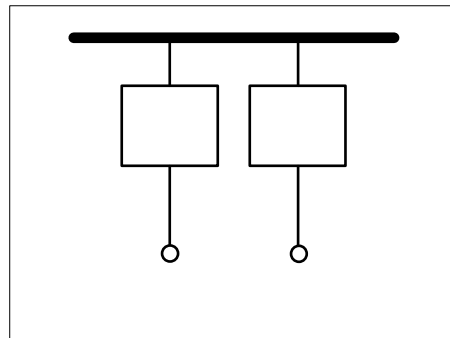

Form 2

Separation of busbars from the functional units

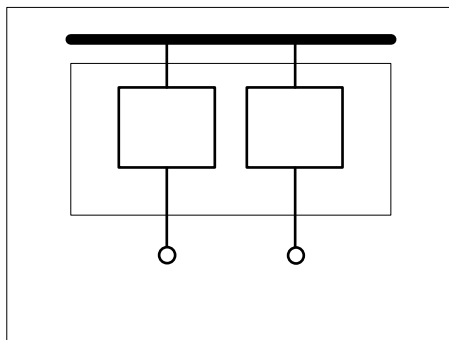

Form 2a:
Terminals not separated from busbars

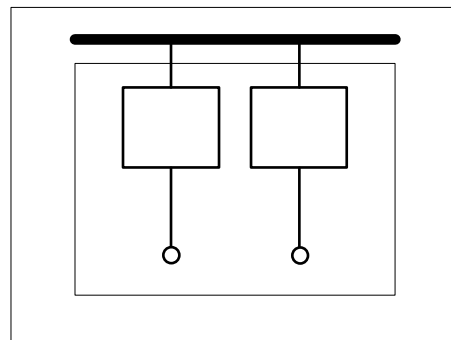

Form 2b:
Terminals separated from busbars

IEC 1121/99

Figure D.2 – Forms 1 and 2

Form 3

Separation of busbars from all functional units
 +
Separation of all functional units from one another
 +
Separation of terminals for external conductors from the functional units, but not from those of other functional units

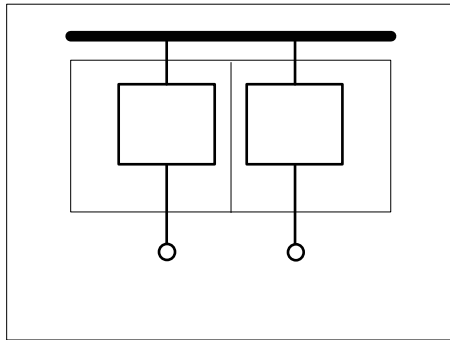

Form 3a:
Terminals not separated from busbars

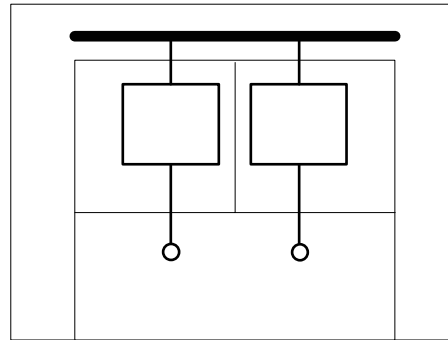

Form 3b:
Terminals separated from busbars

Form 4

Separation of busbars from all functional units
 +
Separation of all functional units from one another
 +
Separation of terminals for external conductors associated with a functional unit from those of any other functional unit and the busbars

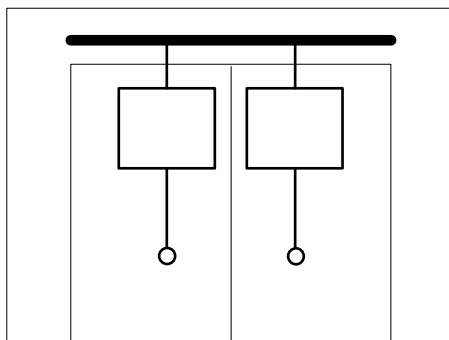

Form 4a:
Terminals in same compartment
as associated functional unit

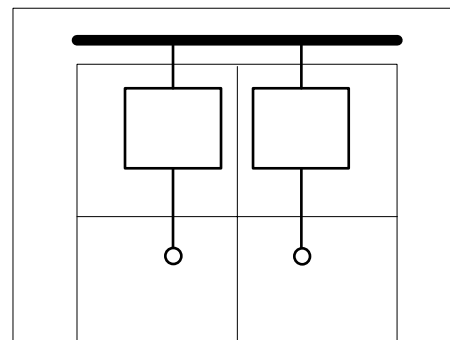

Form 4b:
Terminals not in same compartment
as associated functional unit

IEC 1123/99

Figure D.2 – Forms 3 and 4

Annex E (informative)

Items subject to agreement between manufacturer and user

Subclause of
this standard

4.7	Rated diversity factor
6.1.1.2	(Note) Use of ASSEMBLIES in an arctic climate
6.1.3	(Note) Use of electronic equipment at altitudes above 1 000 m
6.2	Special service conditions
6.2.10	Electrical and radiated interferences
6.3.1	Conditions during transport, storage and erection
7.1.3	Terminals for external conductors
7.2.1.1	Degree of protection required for the intended installation. For floor-mounted ASSEMBLIES, degree of protection of the bottom to be indicated also
7.4.2	Choice of protective measure against direct contact
7.4.3	Choice of protective measure against indirect contact
7.4.6	Accessibility in service by authorized personnel
7.4.6.1	Accessibility for inspection and similar operations
7.4.6.2	Accessibility for maintenance
7.4.6.3	Accessibility for extension under voltage
7.5.2.3	Values of prospective short-circuit current in case of several incoming units or outgoing units for high-power rotating machines
7.5.4	Co-ordination of short-circuit protective devices
7.6.4.1	Insertion interlock
7.6.4.3	Degree of protection after removal of a removable or withdrawable part
7.7	Form of separation
7.9.1	Input voltage variations for electronic equipment supply
7.9.4, item b)	Supply frequency deviation
8.2.1.3.4	Temperature-rise test for values of test current higher than 3 150 A
8.2.1.6	Ambient air temperature for temperature-rise test
8.2.3.2.3, item d)	Value of neutral bar current for short-circuit test
8.3.1	Repetition of electrical operation test on site

Annex F (normative)

Measurement of creepage distances and clearances *

F.1 Basic principles

The widths X of the grooves specified in the following examples 1 to 11 basically apply to all examples as a function of pollution as follows:

Pollution degree	Minimum values of widths X of grooves mm
1	0,25
2	1,0
3	1,5
4	2,5

If the associated clearance is less than 3 mm, the minimum groove width may be reduced to one-third of this clearance.

The methods of measuring creepage distances and clearances are indicated in examples 1 to 11. These examples do not differentiate between gaps and grooves or between types of insulation.

Furthermore:

- any corner is assumed to be bridged with an insulating link of X mm width moved into the most unfavourable position (see example 3);
- where the distance across the top of a groove is X mm or more, a creepage distance is measured along the contours of the grooves (see example 2);
- creepage distances and clearances measured between parts moving in relation to each other are measured when these parts are in their most unfavourable positions.

F.2 Use of ribs

Because of their influence on contamination and their better drying-out effect, ribs considerably decrease the formation of leakage current. Creepage distances can therefore be reduced to 0,8 of the required value, provided the minimum height of the ribs is 2 mm.

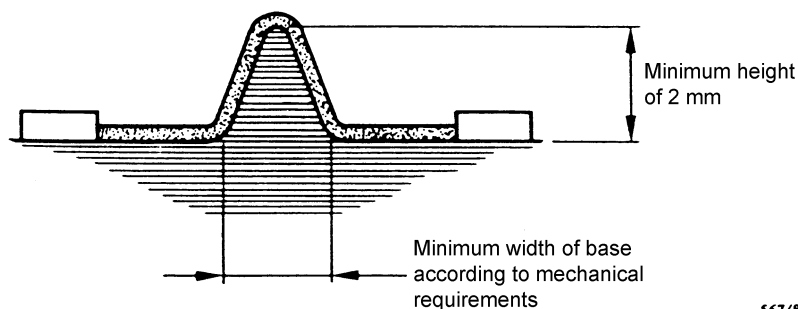
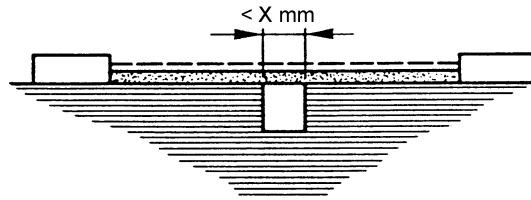

Figure F.1 – Measurement of ribs

567/88

* This annex F is identical with appendix G of IEC 60947-1.

Example 1



127/81

Condition: This creepage distance path includes a parallel- or converging-sided groove of any depth with a width less than X mm.

Rule: Creepage distance and clearance are measured directly across the groove as shown.

Example 2

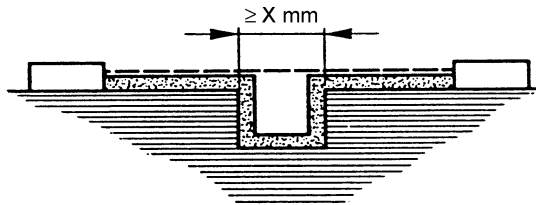

128/81

Condition: This creepage distance path includes a parallel-sided groove of any depth and equal to or more than X mm.

Rule: Clearance is the "line-of-sight" distance. Creepage distance path follows the contour of the groove.

Example 3

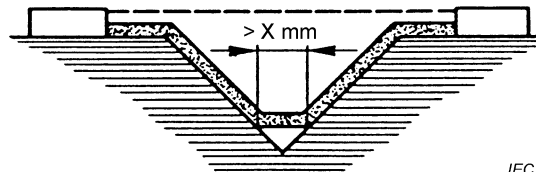

IEC 1124/99

Condition: This creepage distance path includes a V-shaped groove with a width greater than X mm

Rule: Clearance is the "line-of-sight" distance. Creepage distance path follows the contour of the groove but "short-circuits" the bottom of the groove by X mm link.

----- Clearance

██████████ Creepage distance

Example 4

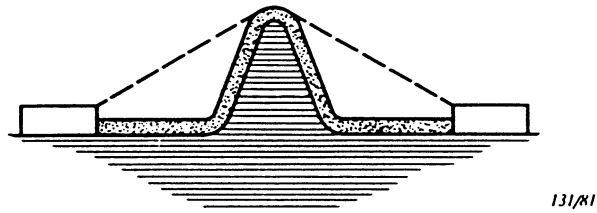

Condition: This creepage distance path includes a rib. Rule: Clearance is the shortest air path over the top of the rib. Creepage path follows the contour of the rib.

Example 5

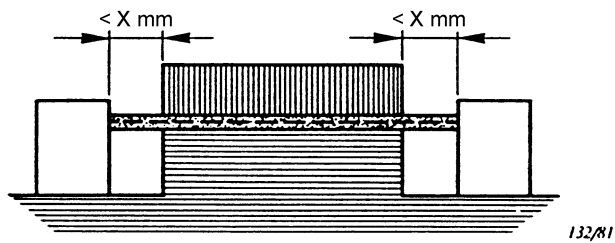

Condition: This creepage distance path includes an uncemented joint with grooves less than X mm wide on each side. Rule: Creepage distance and clearance paths are the "line-of-sight" distance shown.

Example 6

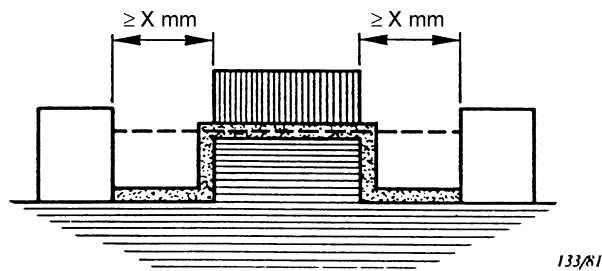

Condition: This creepage distance path includes an uncemented joint with grooves equal to or more than X mm wide on each side. Rule: Clearance is the "line-of-sight" distance. Creepage distance path follows the contour of the grooves.

----- Clearance

██████████ Creepage distance

Example 10

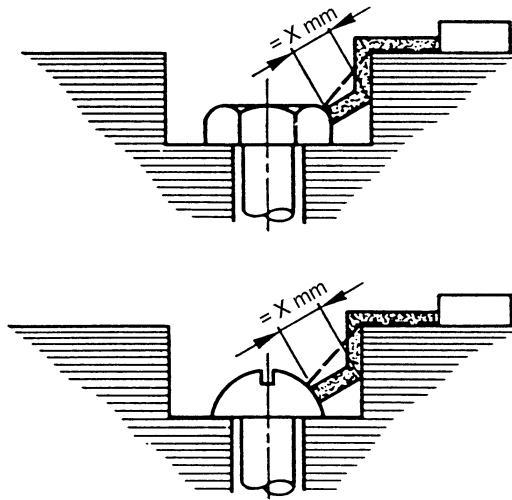

137/81

Condition: Gap between head of screw and wall of recess too narrow to be taken into account.

Rule: Measurement of creepage distance is from screw to wall when the distance is equal to X mm.

Example 11

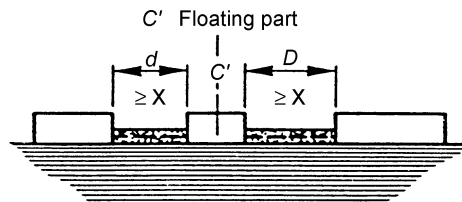

IEC 1126/99

Clearance is the distance $d + D$

Creepage distance is also $d + D$

----- Clearance

██████████ Creepage distance

Annex G (normative)

Correlation between the nominal voltage of the supply system and the rated impulse withstand voltage of the equipment*

INTRODUCTION

This annex is intended to give the necessary information concerning the choice of equipment for use in a circuit within an electrical system or part thereof.

Table G.1 provides examples of the correlation between nominal supply system voltages and the corresponding rated impulse withstand voltage of the equipment.



The values of rated impulse withstand voltage given in table G.1 are based on the performance characteristics of surge arresters. They are based on characteristics in accordance with IEC 60099-1.

It should be recognized that control of overvoltages with respect to the values in table G.1 can also be achieved by conditions in the supply system such as the existence of a suitable impedance or cable feed.

In such cases when the control of overvoltages is achieved by means other than surge arresters, guidance for the correlation between the nominal supply system voltage and the equipment rated impulse withstand voltage is given in IEC 60364-4-443.

* This annex is identical with appendix H of IEC 60947-1.

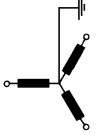
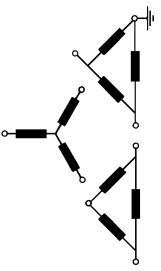
Table G.1 – Correspondence between the nominal voltage of the supply system and the equipment rated impulse withstand voltage, in the case of overvoltage protection by surge-arresters according to IEC 60099-1

Maximum value of rated operational voltage to earth, a.c. r.m.s. or d.c. V	Nominal voltage of the supply system (\leq rated insulation voltage of the equipment) V			Preferred values of rated impulse withstand voltage (1,2/50 μ s) at 2 000 m kV				
	 AC r.m.s.	 AC r.m.s.	 AC r.m.s. or d.c.	 AC r.m.s. or d.c.	IV Origin of installation (service entrance) level	III Distribution circuit level	II Load (appliance, equipment) level	I Specially protected level
50	–	–	12,5, 24, 25, 30, 42, 48	–	1,5	0,8	0,5	0,33
100	66/115	66	60	–	2,5	1,5	0,8	0,5
150	120/208 127/220	115, 120 127	110, 120	220-110, 240-120	4	2,5	1,5	0,8
300	220/380, 230/400 240/415, 260/440 277/480	220, 230 240, 260 277	220	440-220	6	4	2,5	1,5
600	347/600, 380/660 400/690, 415/720 480/830	347, 380, 400 415, 440, 480 500, 577, 600	480	960-480	8	6	4	2,5
1 000	–	660 690, 720 830, 1 000	1 000	–	12	8	6	4

Annex H (normative)

Electromagnetic compatibility (EMC)

H.1 General

This annex applies to electromagnetic compatibility for ASSEMBLIES incorporating electronic circuits, which are not in compliance with 7.10.2.

The subclause numbering within this annex aligns with that of the body of the standard.

H.2 Definitions

H.2.11.1

port

particular interface of the specified apparatus with external electromagnetic environment (see figure H.1)

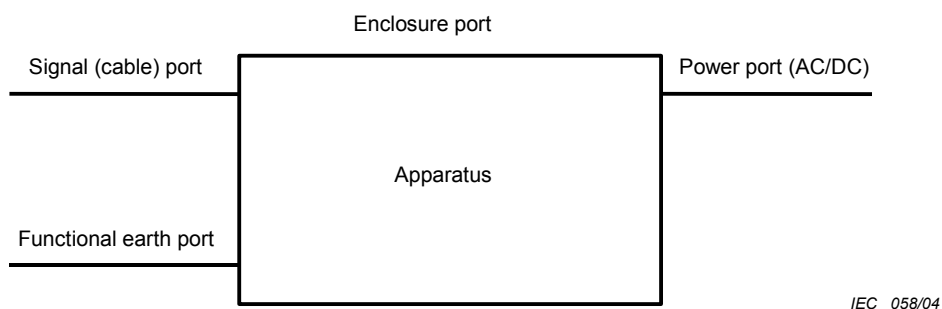

Figure H.1 — Examples of ports

H.2.11.2

enclosure port

physical boundary of the apparatus through which electromagnetic fields may radiate or on which they may impinge

H.2.11.3

cable port

port at which a conductor or a cable is connected to the apparatus

NOTE Examples are signal ports used for the transfer of data.

H.2.11.4

functional earth port

port other than signal, control or power port, intended for connection to earth for purposes other than electrical safety

**H.2.11.5
signal port**

port at which a conductor or cable carrying information for transferring data is connected to the apparatus

NOTE Examples are data buses, communication networks, control networks.

**H.2.11.6
power port**

port at which a conductor or cable carrying the primary electrical power needed for the operation (functioning) of an apparatus or associated apparatus is connected to the apparatus

H.8.2.8 Tests for EMC

Functional units within ASSEMBLIES which do not fulfil the requirements of 7.10.2 a) and b) shall be subjected to the following tests, as applicable.

The emission and immunity tests shall be carried out in accordance with the relevant EMC standard (see tables H.1, H.2, H.3 and H.4); however, the manufacturer shall specify any additional measures necessary to verify the criteria of performance for the ASSEMBLIES if necessary (e.g. application of dwell times).

H.8.2.8.1 Immunity tests

H.8.2.8.1.1 ASSEMBLIES not incorporating electronic circuits

No tests are necessary; see 7.10.3.1.

H.8.2.8.1.2 ASSEMBLIES incorporating electronic circuits

Tests shall be made according to the relevant Environment A or B. The values are given in tables H.3 and/or H.4, except where a different test level is given and justified by the electronic components manufacturer.

Performance criteria shall be stated by the ASSEMBLIES manufacturer based on the acceptance criteria in table H.5.

H.8.2.8.2 Emission tests

H.8.2.8.2.1 ASSEMBLIES not incorporating electronic circuits

No tests are necessary; see 7.10.4.1.

H.8.2.8.2.2 ASSEMBLIES incorporating electronic circuits

The ASSEMBLIES manufacturer shall specify the test methods used; see 7.10.4.2.

Table H.1 – Emission limits for Environment A

Item	Frequency range MHz ^{a)}	Limits	Reference standard
Radiated emissions	30 – 230	30 dB ($\mu\text{V}/\text{m}$) quasi peak at 30 m ^{b)}	IEC 61000-6-4 or CISPR 11, Class A, Group 1
	230 – 1 000	37 dB ($\mu\text{V}/\text{m}$) quasi peak at 30 m ^{b)}	
Conducted emissions	0,15 – 0,5	79 dB (μV) quasi peak 66 dB (μV) average	
	0,5 – 5	73 dB (μV) quasi peak 60 dB (μV) average	
	5 – 30	73 dB (μV) quasi peak 60 dB (μV) average	
NOTE The limits given in this table have been copied from CISPR 11 without alteration.			
^{a)} The lower limit shall apply at the transition frequency.			
^{b)} May be measured at a distance of 10 m with the limits increased by 10 dB or at a distance of 3 m with the limits increased by 20 dB.			

Table H.2 – Emission limits for Environment B

Item	Frequency range MHz ^{a)}	Limits	Reference standard
Radiated emissions	30 – 230	30 dB ($\mu\text{V}/\text{m}$) quasi peak at 10 m ^{b)}	
	230 – 1 000	37 dB ($\mu\text{V}/\text{m}$) quasi peak at 10 m ^{b)}	
Conducted emissions	0,15 – 0,5 The limits decrease linearly with the log of the frequency	66 dB (μV) – 56 dB (μV) quasi peak 56 dB (μV) – 46 dB (μV) average	IEC 61000-6-3 or CISPR 11 Class B, Group 1
	0,5 – 5	56 dB (μV) quasi peak 46 dB (μV) average	
	5 – 30	60 dB (μV) quasi peak 50 dB (μV) average	
NOTE The limits given in this table have been copied from CISPR 11 without alteration.			
^{a)} The lower limit shall apply at the transition frequency.			
^{b)} May be measured at a distance of 3 m with limits increased by 10 dB.			

**Table H.3 – Tests for EMC immunity for Environment A
(see H.8.2.8.1)**

Type of test	Test level required	Performance criterion ^{c)}
Electrostatic discharge immunity test IEC 61000-4-2	± 8 kV / air discharge or ± 4 kV / contact discharge	B
Radiated radio-frequency electromagnetic field immunity test IEC 61000-4-3 at 80 MHz to 1 GHz and 1,4 GHz to 2 GHz	10 V/m	A
Electrical fast transient/burst immunity test IEC 61000-4-4	± 2 kV on supply ports ± 1 kV on signal ports including auxiliary circuits	B
1,2/50 µs and 8/20 µs surge immunity test IEC 61000-4-5 ^{a)}	± 2 kV (line to earth) ± 1 kV (line to line)	B
Conducted radio-frequency immunity test IEC 61000-4-6 at 150 kHz to 80 MHz	10 V	A
Immunity to power-frequency magnetic fields IEC 61000-4-8	30 A/m ^{b)}	A
Immunity to voltage dips and interruptions IEC 61000-4-11	30 % reduction for 0,5 cycles	B
	60 % reduction for 5 and 50 cycles	C
	>95 % reduction for 250 cycles	C
Immunity to harmonics in the supply IEC 61000-4-13	No requirements	
^{a)} For equipment and/or input/output ports with a rated d.c. voltage of 24 V or less, tests are not required. ^{b)} Applicable only to apparatus containing devices susceptible to magnetic fields. ^{c)} Performance criteria are independent of the environment. See table H.5.		

**Table H.4 – Tests for EMC immunity for Environment B
(see H.8.2.8.1)**

Type of test	Test level required	Performance criterion ^{c)}
Electrostatic discharge immunity test IEC 61000-4-2	± 8 kV / air discharge or ± 4 kV / contact discharge	B
Radiated radio-frequency electromagnetic field immunity test IEC 61000-4-3 at 80 MHz to 1 GHz and 1,4 GHz to 2 GHz	3 V/m	A
Electrical fast transient/burst immunity test IEC 61000-4-4	± 1 kV on supply ports ± 0,5 kV on signal ports including auxiliary circuits	B
1,2/50 µs and 8/20 µs surge immunity test IEC 61000-4-5 ^{a)}	± 0,5 kV (line to earth) except for mains supply input port where ± 1 kV applies (line to earth) ± 0,5 kV (line to line)	B
Conducted radio-frequency immunity test IEC 61000-4-6 at 150 kHz to 80 MHz	3 V	A
Immunity to power-frequency magnetic fields IEC 61000-4-8	3 A/m ^{b)}	A
Immunity to voltage dips and interruptions IEC 61000-4-11 ^{d)}	30 % reduction for 0,5 cycles 60 % reduction for 5 cycles >95 % reduction for 250 cycles	B C C
Immunity to harmonics in the supply IEC 61000-4-13	No requirements	
<p>^{a)} For equipment and/or input/output ports with a rated d.c. voltage of 24 V or less, tests are not required.</p> <p>^{b)} Applicable only to apparatus containing devices susceptible to magnetic fields.</p> <p>^{c)} Performance criteria are independent of the environment. See table H.5.</p> <p>^{d)} Applicable only to mains input power ports.</p>		

Table H.5 – Acceptance criteria when electromagnetic disturbances are present

Item	Acceptance criteria (performance criteria during tests)		
	A	B	C
Overall performance	No noticeable changes of the operating characteristic. Operating as intended	Temporary degradation or loss of performance which is self-recoverable	Temporary degradation or loss of performance which requires operator intervention or system reset ^{a)}
Operation of power and auxiliary circuits	No maloperation	Temporary degradation or loss of performance which is self-recoverable ^{a)}	Temporary degradation or loss of performance which requires operator intervention or system reset ^{a)}
Operation of displays and control panels	No changes to visible display information. Only slight light intensity fluctuation of LEDs, or slight movement of characters	Temporary visible changes, or loss of information. Undesired LED illumination	Shut down. Permanent loss of display or wrong information. Unpermitted operating mode. Not self-recoverable
Information processing and sensing functions	Undisturbed communication and data interchange to external devices	Temporarily disturbed communication, with possible error reports of the internal and external devices	Erroneous processing of information. Loss of data and/or information. Errors in communication. Not self-recoverable

^{a)} Specific requirements shall be detailed in the product standard.

Bibliography

IEC 60050-195, *International Electrotechnical Vocabulary (IEV) – Part 195: Earthing and protection against electric shock*

IEC 60050(601), *International Electrotechnical Vocabulary (IEV) – Chapter 601: Generation, transmission and distribution of electricity – General*

IEC 60050(826), *International Electrotechnical Vocabulary (IEV) – Chapter 826: Electrical installations of buildings*

IEC 60364-5-537:1981, *Electrical installations of buildings – Part 5: Selection and erection of electrical equipment – Chapter 53: Switchgear and controlgear – Section 537: Devices for isolation and switching*

IEC 61000-6-1:1997, *Electromagnetic compatibility (EMC) – Part 6-1: Generic standards – Immunity for residential, commercial and light-industrial environments*

IEC 61000-6-2:1999, *Electromagnetic compatibility (EMC) – Part 6-2: Generic standards – Immunity for industrial environments*

Annex ZA (normative)

Normative references to international publications with their corresponding European publications

This European Standard incorporates by dated or undated reference, provisions from other publications. These normative references are cited at the appropriate places in the text and the publications are listed hereafter. For dated references, subsequent amendments to or revisions of any of these publications apply to this European Standard only when incorporated in it by amendment or revision. For undated references the latest edition of the publication referred to applies (including amendments).

NOTE When an international publication has been modified by CENELEC common modifications, indicated by (mod), the relevant EN/HD applies.

Publication	Year	Title	EN/HD	Year
IEC 60038 (mod)	1983	<i>IEC standard voltages</i> ¹⁾	HD 472 S1	1989
IEC 60050-441	1984	<i>International Electrotechnical Vocabulary (IEV) — Chapter 441: Switchgear, controlgear and fuses</i>	—	—
IEC 60050-471	1984	<i>Chapter 471: Insulators</i>	—	—
IEC 60050-604	1987	<i>Chapter 604: Generation, transmission and distribution of electricity — Operation</i>	—	—
IEC 60060	series	<i>High-voltage test techniques</i>	HD 588.1 S1 EN 60060-2 + A11	1991 1994 1998
IEC 60071-1	1976 ²⁾	<i>Insulation co-ordination — Part 1: Terms, definitions, principles and rules</i>	—	—
IEC 60073	1996	<i>Basic and safety principles for man-machine interface, marking and identification — Coding principles for indication devices and actuators</i>	EN 60073	1996
IEC 60099-1	1991	<i>Surge arresters — Part 1: Non-linear resistor type gapped surge arresters for a.c. systems</i>	EN 60099-1	1994
IEC 60112	1979	<i>Method for determining the comparative and the proof tracking indices of solid insulating materials under moist conditions</i>	HD 214 S2	1980
IEC 60146-2	1974	<i>Semiconductors converters — Part 2: Semiconductor self-commutated converters</i>	—	—
IEC 60158-2 (mod)	1982	<i>Low-voltage controlgear — Part 2: Semiconductor contactors (solid state contactors)</i>	HD 419.2 S1	1987
IEC 60204-1	1997	<i>Safety of machinery — Electrical equipment of machines — Part 1: General requirements</i>	EN 60204-1 + corr. September 1998	1997 1998
IEC 60227-3 (mod)	1993	<i>Polyvinyl chloride insulated cables of rated voltages up to and including 450/750 V — Part 3: Non-sheathed cables for fixed wiring</i>	HD 21.3 S3	1995

¹⁾ The title of HD 472 S1 is: Nominal voltages for low-voltage public electricity supply systems.

²⁾ IEC 60071-1:1993 is harmonized as EN 60071-1:1995.

<u>Publication</u>	<u>Year</u>	<u>Title</u>	<u>EN/HD</u>	<u>Year</u>
IEC 60227-4	1992 ³⁾	<i>Part 4: Sheathed cables for fixed wiring</i>	—	—
IEC 60245-3	1994 ⁴⁾	<i>Rubber insulated cables of rated voltages up to and including 450/750 V — Part 3: Heat resistant silicone insulated cables</i>	—	—
IEC 60245-4 (mod)	1994	<i>Part 4: Cords and flexible cables</i>	HD 22.4 S3	1995
IEC 60269	series	<i>Low-voltage fuses</i>	EN 60269 HD 630	series series
IEC 60364-3 (mod)	1993	<i>Electrical installations of buildings — Part 3: Assessment of general characteristics</i>	HD 384.3 S2	1995
IEC 60364-4-41 (mod)	1992	<i>Part 4: Protection for safety — Chapter 41: Protection against electric shock</i>	HD 384.4.41 S2	1996
IEC 60364-4-443 (mod)	1995	<i>Chapter 44: Protection against overvoltages — Section 443: Protection against overvoltages of atmospheric origin or due to switching</i>	HD 384.4.443 S1	1999
IEC 60364-4-46 (mod)	1981	<i>Chapter 46: Isolation and switching</i>	HD 384.4.46 S1	1987
IEC 60364-5-54 (mod)	1980	<i>Part 5: Selection and erection of electrical equipment — Chapter 54: Earthing arrangements and protective conductors</i>	HD 384.5.54 S1	1988
IEC 60417	1973	<i>Graphical symbols for use on equipment Index, survey and compilation of the single sheets</i>	HD 243 S12 ⁵⁾	1995
IEC 60445	1988	<i>Identification of equipment terminals and of terminations of certain designated conductors, including general rules for an alphanumeric system</i>	EN 60445	1990
IEC 60446	1989 ⁶⁾	<i>Identification of conductors by colours or numerals</i>	—	—
IEC 60447	1993	<i>Man-machine interface (MMI) — Actuating principles</i>	EN 60447	1993
IEC 60502	1994	<i>Extruded solid dielectric insulated power cables for rated voltages from 1 kV up to 30 kV</i>	—	—
IEC 60529	1989	<i>Degrees of protection provided by enclosures (IP Code)</i>	EN 60529 + corr. May	1991 1993
IEC 60664-1 (mod)	1992	<i>Insulation coordination for equipment within low-voltage systems — Part 1: Principles, requirements and tests</i>	HD 625.1 S1 + corr. November	1996 1996
IEC 60695-2-10	2000	<i>Fire hazard testing — Part 2-10: Glowing/hot-wire based test methods — Glow-wire apparatus and common test procedure</i>	EN 60695-2-10	2001
IEC 60695-2-11	2000	<i>Part 2-11: Glowing/hot-wire based test methods — Glow-wire flammability test method for end-products</i>	EN 60695-2-11	2001

³⁾ IEC 60227-4:1979, mod., is harmonized as HD 21.4 S2:1990.

⁴⁾ IEC 60245-3:1980, mod., is harmonized as HD 22.3 S3:1995.

⁵⁾ HD 243 S12 includes supplements A:1974 to M:1994 to IEC 60417.

⁶⁾ IEC 60446:1999 is harmonized as EN 60446:1999.

Publication	Year	Title	EN/HD	Year
IEC 60865	series	<i>Short-circuit currents — Calculation of effects</i>	EN 60865	series
IEC 60890	1987	<i>A method of temperature-rise assessment by extrapolation for partially type-tested assemblies (PTTA) of low-voltage switchgear and controlgear</i>	HD 528 S2	1997
+ corr. March + A1	1988 1995			
IEC 60947-1 (mod)	1988	<i>Low-voltage switchgear and controlgear — Part 1: General rules</i>	EN 60947-1 ⁷⁾ + corr. June	1991 1997
IEC 60947-3	1999	<i>Part 3: Switches, disconnectors, switch-disconnectors and fuse-combination units</i>	EN 60947-3	1999
IEC 60947-4-1	1990	<i>Part 4: Contactors and motor-starters — Section 1: Electromechanical contactors and motor-starters</i>	EN 60947-4-1 + corr. June	1992 1997
IEC 61000-3-2 (mod)	2000	<i>Electromagnetic compatibility (EMC) — Part 3-2: Limits — Limits for harmonic current emissions (equipment input current up to and including 16 A per phase)</i>	EN 61000-3-2	2000
IEC 61000-4-2	1995	<i>Part 4-2: Testing and measurement techniques — Electrostatic discharge immunity test — Basic EMC publication</i>	EN 61000-4-2	1995
IEC 61000-4-3	2002	<i>Part 4-3: Testing and measurement techniques — Radiated, radio-frequency, electromagnetic field immunity test</i>	EN 61000-4-3	2002
IEC 61000-4-4	1995	<i>Part 4-4: Testing and measurement techniques — Electrical fast transient/burst immunity test — Basic EMC publication</i>	EN 61000-4-4	1995
IEC 61000-4-5	1995	<i>Part 4-5: Testing and measurement techniques — Surge immunity test</i>	EN 61000-4-5	1995
IEC 61000-4-6	2003	<i>Part 4-6: Testing and measurement techniques — Immunity to conducted disturbances, induced by radio-frequency fields</i>	—	—
IEC 61000-4-8	1993	<i>Part 4-8: Testing and measurement techniques — Power frequency magnetic field immunity test</i>	EN 61000-4-8	1993
IEC 61000-4-11	1994	<i>Part 4-11: Testing and measurement techniques — Voltage dips, short interruptions and voltage variations immunity tests</i>	EN 61000-4-11	1994
IEC 61000-4-13	2002	<i>Part 4-13: Testing and measurement techniques — Harmonics and interharmonics including mains signalling at a.c. power port, low frequency immunity tests</i>	EN 61000-4-13	2002
IEC 61000-6-3 (mod)	1996	<i>Part 6-3: Generic standards — Emission standard for residential, commercial and light-industrial environments</i>	EN 61000-6-3	2001
IEC 61000-6-4 (mod)	1997	<i>Part 6-4: Generic standards — Emission standard for industrial environments</i>	EN 61000-6-4	2001
IEC 61082	series	<i>Preparation of documents used in electrotechnology</i>	EN 61082	series

⁷⁾ EN 60947-1 is superseded by EN 60947-1:1999, which is based on IEC 60947-1:1999.

<u>Publication</u>	<u>Year</u>	<u>Title</u>	<u>EN/HD</u>	<u>Year</u>
IEC 61117	1992	<i>A method for assessing the short-circuit withstand strength of partially type-tested assemblies (PPTA)</i>	—	—
IEC 61346-1	1996	<i>Industrial systems, installations and equipment and industrial products — Structuring principles and reference designations — Part 1: Basic rules</i>	EN 61346-1	1996
CISPR 11 (mod)	1997	<i>Industrial, scientific and medical (ISM) radio-frequency equipment — Radio disturbance characteristics — Limits and methods of measurement</i>	EN 55011	1998
A1	1999		A1	1999

National annex NA (informative)

Guide to the internal separation of ASSEMBLIES

The internal separation of ASSEMBLIES by barriers or partitions is specified in 7.7 and is subject to agreement between the manufacturer and the user.

Table NA.1 gives additional information regarding different types of construction, based on typical practice in the United Kingdom. Other types of construction are not precluded, and it is not essential to adopt any of the listed types in order to comply with the requirements of this British Standard. However, in order to achieve agreement between manufacturers and users, it is recommended to adopt one of the listed types of construction.

Table NA.1 Forms of			
Mains criteria	Sub-criteria	Form	Type of construction
No separation.		Form 1	
Separation of busbars from the functional units	Terminals for external conductors not separated from busbars	Form 2a	
	Terminals for external conductors separated from busbars	Form 2b	Type 1 Busbar separation is achieved by insulated covering, e.g. sleeving, wrapping or coatings ¹⁾ Type 2 Busbar separation is by metallic or non-metallic rigid barriers or partitions
Separation of busbars from the functional units and separation of all functional units from one another	Terminals for external conductors not separated from busbars	Form 3a	
	Terminals for external conductors separated from busbars	Form 3b	Type 1 Busbar separation is achieved by insulated covering, e.g. sleeving, wrapping or coatings ¹⁾ Type 2 Busbar separation is by metallic or non-metallic rigid barriers or partitions
Separation of the terminals for external conductors from the functional units, but not from each other			
Separation of busbars from the functional units and separation of all functional units from one another, including the terminals for external conductors which are an integral part of the functional unit	Terminals for external conductors in same compartment as the associated functional unit	Form 4a	Type 1 Busbar separation is achieved by insulated covering, e.g. sleeving, wrapping or coatings ¹⁾ Cables may be glanded elsewhere
			Type 2 Busbar separation is by metallic or non-metallic rigid barriers or partitions Cables may be glanded elsewhere
			Type 3 Busbar separation is by metallic or non-metallic rigid barriers or partitions The termination for each functional unit has its own integral glanding facility
	Terminals for external conductors not in the same compartment as the associated functional unit, but in individual, separate, enclosed protected spaces or compartments	Form 4b	Type 4 Busbar separation is achieved by insulated coverings, e.g. sleeving, wrapping or coatings ¹⁾ Cables may be glanded elsewhere Type 5 Busbar separation is by metallic or non-metallic rigid barriers or partitions Terminals may be separated by insulated coverings ¹⁾ and glanded in common cabling chamber(s) Type 6 All separation requirements are by metallic or non-metallic rigid barriers or partitions Cables are glanded in common cabling chamber(s) Type 7 All separation requirements are by metallic or non-metallic rigid barriers or partitions The termination for each functional unit has its own integral glanding facility

¹⁾ See 7.4.2.1 in relation to protection against contact with live parts.

NOTE. Conductors which are connected to a functional unit but where they are external to its compartment or enclosed protected space (e.g. control cables connected to a common marshalling compartment) are not considered to form part of the functional unit.

BSI — British Standards Institution

BSI is the independent national body responsible for preparing British Standards. It presents the UK view on standards in Europe and at the international level. It is incorporated by Royal Charter.

Revisions

British Standards are updated by amendment or revision. Users of British Standards should make sure that they possess the latest amendments or editions.

It is the constant aim of BSI to improve the quality of our products and services. We would be grateful if anyone finding an inaccuracy or ambiguity while using this British Standard would inform the Secretary of the technical committee responsible, the identity of which can be found on the inside front cover.
Tel: +44 (0)20 8996 9000. Fax: +44 (0)20 8996 7400.

BSI offers members an individual updating service called PLUS which ensures that subscribers automatically receive the latest editions of standards.

Buying standards

Orders for all BSI, international and foreign standards publications should be addressed to Customer Services. Tel: +44 (0)20 8996 9001.
Fax: +44 (0)20 8996 7001. Email: orders@bsi-global.com. Standards are also available from the BSI website at <http://www.bsi-global.com>.

In response to orders for international standards, it is BSI policy to supply the BSI implementation of those that have been published as British Standards, unless otherwise requested.

Information on standards

BSI provides a wide range of information on national, European and international standards through its Library and its Technical Help to Exporters Service. Various BSI electronic information services are also available which give details on all its products and services. Contact the Information Centre.
Tel: +44 (0)20 8996 7111. Fax: +44 (0)20 8996 7048. Email: info@bsi-global.com.

Subscribing members of BSI are kept up to date with standards developments and receive substantial discounts on the purchase price of standards. For details of these and other benefits contact Membership Administration.
Tel: +44 (0)20 8996 7002. Fax: +44 (0)20 8996 7001.
Email: membership@bsi-global.com.

Information regarding online access to British Standards via British Standards Online can be found at <http://www.bsi-global.com/bsonline>.

Further information about BSI is available on the BSI website at <http://www.bsi-global.com>.

Copyright

Copyright subsists in all BSI publications. BSI also holds the copyright, in the UK, of the publications of the international standardization bodies. Except as permitted under the Copyright, Designs and Patents Act 1988 no extract may be reproduced, stored in a retrieval system or transmitted in any form or by any means – electronic, photocopying, recording or otherwise – without prior written permission from BSI.

This does not preclude the free use, in the course of implementing the standard, of necessary details such as symbols, and size, type or grade designations. If these details are to be used for any other purpose than implementation then the prior written permission of BSI must be obtained.

Details and advice can be obtained from the Copyright & Licensing Manager.
Tel: +44 (0)20 8996 7070. Fax: +44 (0)20 8996 7553.
Email: copyright@bsi-global.com.