

Electrical insulating materials — Determination of electrolytic corrosion caused by insulating materials — Test methods

The European Standard EN 60426:2007 has the status of a
British Standard

ICS 17.220.99; 29.035.01

National foreword

This British Standard was published by BSI. It is the UK implementation of EN 60426:2007. It is identical with IEC 60426:2007. It supersedes BS 5735:1979, which is withdrawn.

The UK participation in its preparation was entrusted to Technical Committee GEL/112, Evaluation and qualification of electrical insulating materials and systems.

A list of organizations represented on GEL/112 can be obtained on request to its secretary.

This publication does not purport to include all the necessary provisions of a contract. Users are responsible for its correct application.

Compliance with a British Standard cannot confer immunity from legal obligations.

This British Standard was published under the authority of the Standards Policy and Strategy Committee on 30 March 2007

© BSI 2007

ISBN 978 0 580 50417 4

Amendments issued since publication

Amd. No.	Date	Comments

EUROPEAN STANDARD

EN 60426

NORME EUROPÉENNE

EUROPÄISCHE NORM

February 2007

ICS 17.220.99; 29.035.01

English version

**Electrical insulating materials -
Determination of electrolytic corrosion caused by insulating materials -
Test methods
(IEC 60426:2007)**

Matériaux isolants électriques -
Détermination de la corrosion
électrolytique en présence
de matériaux isolants -
Méthodes d'essais
(CEI 60426:2007)

Elektroisolierstoffe -
Prüfungen zur Bestimmung
der elektrolytischen Korrosionswirkung
von Isoliermaterialien
(IEC 60426:2007)

This European Standard was approved by CENELEC on 2007-02-01. CENELEC members are bound to comply with the CEN/CENELEC Internal Regulations which stipulate the conditions for giving this European Standard the status of a national standard without any alteration.

Up-to-date lists and bibliographical references concerning such national standards may be obtained on application to the Central Secretariat or to any CENELEC member.

This European Standard exists in three official versions (English, French, German). A version in any other language made by translation under the responsibility of a CENELEC member into its own language and notified to the Central Secretariat has the same status as the official versions.

CENELEC members are the national electrotechnical committees of Austria, Belgium, Bulgaria, Cyprus, the Czech Republic, Denmark, Estonia, Finland, France, Germany, Greece, Hungary, Iceland, Ireland, Italy, Latvia, Lithuania, Luxembourg, Malta, the Netherlands, Norway, Poland, Portugal, Romania, Slovakia, Slovenia, Spain, Sweden, Switzerland and the United Kingdom.

CENELEC

European Committee for Electrotechnical Standardization
Comité Européen de Normalisation Electrotechnique
Europäisches Komitee für Elektrotechnische Normung

Central Secretariat: rue de Stassart 35, B - 1050 Brussels

© 2007 CENELEC - All rights of exploitation in any form and by any means reserved worldwide for CENELEC members.

Ref. No. EN 60426:2007 E

Foreword

The text of document 112/45/FDIS, future edition 2 of IEC 60426, prepared by IEC TC 112, Evaluation and qualification of electrical insulating materials and systems, was submitted to the IEC-CENELEC parallel vote and was approved by CENELEC as EN 60426 on 2007-02-01.

The following dates were fixed:

- latest date by which the EN has to be implemented
at national level by publication of an identical
national standard or by endorsement (dop) 2007-11-01
- latest date by which the national standards conflicting
with the EN have to be withdrawn (dow) 2010-02-01

Annex ZA has been added by CENELEC.

Endorsement notice

The text of the International Standard IEC 60426:2007 was approved by CENELEC as a European Standard without any modification.

CONTENTS

INTRODUCTION.....	5
1 Scope	6
2 Normative references	6
3 Terms and definitions	6
4 General description of the test method	7
5 Test specimens	7
5.1 General	7
5.2 Cut surfaces of rigid materials (blocks, plates, sheets or semi-finished materials)	8
5.3 Cast, moulding, injection and pressed materials	8
5.4 Cut surfaces of flexible films, foils and thin sheets	8
5.5 Adhesive tapes	9
5.6 Flexible sleeving and tubing	9
5.7 Lacquers and insulating varnishes	9
5.8 Cleanliness of contact surfaces	9
5.9 Number of test specimens	10
6 Test strips	10
6.1 General	10
6.2 Preparation of the test strips	10
6.3 Cleanliness of test strips	11
7 Test device	11
8 Test conditions	13
9 Test procedure	13
10 Evaluation	13
10.1 General evaluation	13
10.2 Visual inspection of the test strips	14
10.3 Tensile strength of test strips	14
11 Evaluation of corrosion on copper strips	15
12 Test report	16
Annex A (normative) Tables for the evaluation of corrosion on brass and aluminium strips	17
Annex B (informative) Notes on visual evaluation	19
Annex C (informative) Copper wire tensile strength method	20
Annex ZA (normative) Normative references to international publications with their corresponding European publications	26
Figure 1 – Test specimen of rigid material, for example textile laminate	7
Figure 2 – Test specimen of flexible material, for example flexible films, foils etc.	9
Figure 3 – Test strip	11
Figure 4 – Test device for determining electrolytic corrosion	12
Figure C.1 – Apparatus for determining electrolytic corrosion of rigid insulating material	22
Figure C.2 – Apparatus for determining electrolytic corrosion of flexible insulating material ..	22

Table 1 – Degrees of corrosion of copper strips..... 15
Table A.1 – Degrees of corrosion of brass strips..... 17
Table A.2 – Degrees of corrosion of aluminium strips 18

INTRODUCTION

Electrical insulating materials at high atmospheric humidity and under influence of electric stress may cause corrosion of metal parts being in contact with them. Such electrolytic corrosion is dependent upon the composition of the insulating material and the character of the metal; it is influenced by temperature, relative humidity, nature of the voltage and the time of exposure. Direct voltage produces much more rapid and extensive corrosion than alternating voltage. Corrosion is more pronounced at the positive electrode.

Not only copper but also most other metals, except the noble metals such as platinum or gold, are subject to electrolytic corrosion. Electrolytic corrosion, however, is usually determined with insulating materials in contact with copper, brass or aluminium. Copper, however, is a basic metal and most frequently used in electrotechnical, teletechnical and electronic equipment, especially for current conducting parts and therefore it was chosen as a basic test metal. Other metals may be used when needed for special purposes, but the results may differ from those described in this method.

Electrolytic corrosion may cause open-circuit failure in electrical conductors and devices. It may promote low resistance leakage path across or through electrical insulation and the products of corrosion may otherwise interfere with the operation of electrical devices, i.e. may prevent operation of contacts, etc.

Electronic equipment operating under conditions of high humidity and elevated temperature may be particularly subjected to failure from electrolytic corrosion. Therefore, the selection of insulating materials, which do not produce electrolytic corrosion, is important for such applications.

The test method described in this second edition replaces two separate methods of the first edition – visual and tensile strength method. The former tensile strength method of the first edition, using copper wires, has been maintained in an informative annex. It must be emphasized that the advantage of this new method is that the same strip used for visual inspection is next used for the tensile strength test in opposite to the method described in the first edition. Therefore the correlation between tensile strength and visual examination is more obvious.

ELECTRICAL INSULATING MATERIALS –

DETERMINATION OF ELECTROLYTIC CORROSION CAUSED BY INSULATING MATERIALS – TEST METHODS

1 Scope

This standard determines the ability of insulating materials to produce electrolytic corrosion on metals being in contact with them under the influence of electric stress, high humidity and elevated temperature.

The effect of electrolytic corrosion is assessed in one test by using consecutively two methods:

- visual semi-quantitative method consisting in comparing visually the corrosion appearing on the anode and cathode metal strips, with those given in the reference figures.

This method consists of the direct visual assessment of the degree of corrosion of two copper strips, acting as anode and cathode respectively, placed in contact with the tested insulating material under a d.c. potential difference at specified environmental conditions. The degree of corrosion is assessed by visually comparing the corrosion marks on the anode and cathode metal strips with those shown in the reference figures;

- quantitative method, which involves the tensile strength measurement, carried out on the same anode and cathode metal strips after visual inspection.

An additional quantitative test method for determining electrolytic corrosion, which involves tensile strength measurement of copper wire, is described in the informative Annex C.

2 Normative references

The following referenced documents are indispensable for the application of this document. For dated references, only the edition cited applies. For undated references, the latest edition of the referenced document (including any amendments) applies.

IEC 60068-3-4:2001, *Environmental testing – Part 3-4: Supporting documentation and guidance – Damp heat tests*

IEC 60454-2:—, *Pressure-sensitive adhesive tapes for electrical purposes – Part 2: Methods of test*¹

3 Terms and definitions

For the purposes of this document the following terms and definitions apply:

3.1 electrolytic corrosion

kind of galvanic corrosion caused by joint action of external source of d.c. potential and some substances included in some organic materials in presence of high humidity and elevated temperature

¹ To be published

3.2

test strip

a) positive

a metal strip connected with positive pole of direct current source which forms the anode in the contact system: metal – insulating material

b) negative

a metal strip connected with negative pole of direct current source which forms the cathode in the contact system: metal – insulating material

3.3

surface of contact

a) of tested material

part of insulating material specimen which is in direct contact with metal strips

b) of metal strip

part of metal strip (positive or negative) which is in direct contact with insulating material specimen

4 General description of the test method

The test consists of applying specified environmental conditions and a d.c. potential difference to two parallel copper strips 3 mm apart, acting as the anode and the cathode respectively. The insulating material under test (test specimen) is placed across these two strips. In order to obtain a good and uniform contact between the metal strips and the material under test, the test specimen is pressed to the strips by a cylindrical loading tube.

5 Test specimens

5.1 General

The preparation of the specimens depends on the type of material and the form in which it is supplied. The shape and dimensions of the test specimen are shown in Figure 1. Procedures for the preparation of the test specimen are reported beneath (5.2 to 5.7).

Dimensions in millimetres

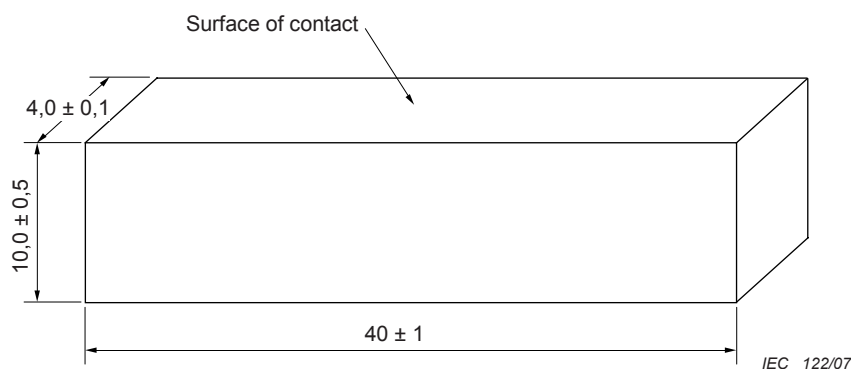

Figure 1 – Test specimen of rigid material, for example textile laminate

5.2 Cut surfaces of rigid materials (blocks, plates, sheets or semi-finished materials)

The test specimens shall be cut out or machined from the tested material to a thickness of 4 mm, by means of a dry method without the use of cutting oils or lubricants and without overheating or damaging them. It is recommended to take several test specimens from various layers of the product.

It is permissible to use the test specimens of thickness smaller than 4 mm, but not smaller than 2 mm.

The contact surface of the test specimen shall be smoothed using abrasive paper. Care should be taken to keep parallelism of the opposite surfaces of the test specimen, in order to assure a good contact of the test specimen to the metal strips. The surface of contact should not show any flaws, cracks, inclusions or bubbles.

The abrasive paper shall not contain any contaminations causing a bad corrosion index, for example halogen components.

5.3 Cast, moulding, injection and pressed materials

From insulating materials delivered in the form of liquid resin, moulding powder or granules, the test specimens shall be made in shapes and dimensions as shown in Figure 1. The specimens shall be made by casting or pressing in a special mould, following exactly the technological instruction recommended by the manufacturer of the tested material.

The test specimen and surface of contact shall be prepared as given in 5.2.

5.4 Cut surfaces of flexible films, foils and thin sheets

Test specimens of these products shall be made up in layers to form small packs placed between suitable holding plates of insulating material not causing electrolytic corrosion itself, for example polymethylmethacrylate (Plexiglas®²). The preferred thickness of holding plates is 1 mm ± 0,2 mm.

The thickness of a pack should be approximately of 4 mm or 2 mm, depending on the thickness of the tested foils. The value of 4 mm is recommended in the case of the single foil thickness being less than 2 mm and more than 0,5 mm, whereas that one of 2 mm is recommended if the single foil thickness is less than 0,5 mm.

These test blocks shall be compressed with screws made of the same material as holding plates and then machined to the appropriate shape as shown in Figure 2. The material to be tested should protrude 0,2 mm to 0,5 mm beyond the holding plates.

² Plexiglas® is an example of a suitable product available commercially. This information is given for the convenience of users of this document and does not constitute an endorsement by IEC of this product.

Dimensions in millimetres

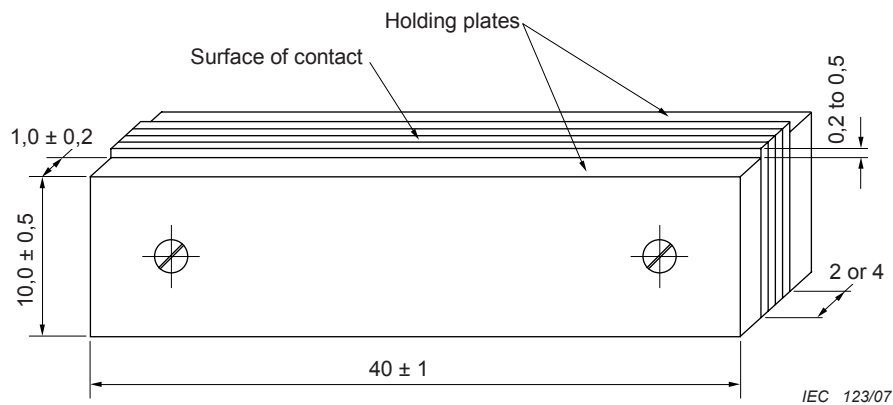

Figure 2 – Test specimen of flexible material, for example flexible films, foils etc.

Apart from this, the particulars given in 5.2 apply.

5.5 Adhesive tapes

For adhesive tapes the method of Clause 7 of IEC 60454-2 is recommended.

5.6 Flexible sleeving and tubing

Sleeving and tubing (both varnished fabric and extruded) are slit open, so as to make flat sheets, which can then be prepared as for films (see 5.4).

5.7 Lacquers and insulating varnishes

The lacquer or insulating varnish to be tested shall be applied in the manner recommended by the manufacturer to the surface of a test specimen of shape as shown in Figure 1 and described in 5.2. The base material of the test specimen shall be a corrosion free plastic such as polymethylmethacrylate.

In case of solvent incompatibility or a baking temperature being too high for the base material, another suitable base material such as cast, hot cured corrosion free epoxy resin or glass shall be used. If the lacquer or insulating varnish is designed to contribute freedom from corrosion to another material, a test specimen of that material shall be used.

The tested lacquer or varnish shall be sprayed, dipped or otherwise coated to the desired thickness and baked, if necessary, as specified or according to the directions of the manufacturer.

If the thickness of coating is not determined by specification or direction of the manufacturer, it shall be of $(30 \pm 10) \mu\text{m}$.

5.8 Cleanliness of contact surfaces

When preparing and handling the test specimens, any soiling of the test surfaces, for example by perspiration from the hands, shall be avoided. The specimens shall be touched only with a pair of tweezers or with protecting gloves made of materials free from corrosion (e.g. polyethylene). After the test specimens have been machined or cut, their surfaces shall be cleaned with a soft brush. Before cleaning, the brush shall be rinsed in ethanol (96 %) and then dried.

After the cleaning procedure, the surface of contact shall not show any foreign particles, residues of oil or grease, no mould residues, etc.

5.9 Number of test specimens

At least five test specimens made from the same material shall be tested at the same time.

A specific sampling procedure may be desired. If necessary, such a sampling procedure should be specified and used.

6 Test strips

6.1 General

The test strips shall be made of 0,1 mm thick, semi-hard copper of purity 99,9 Cu. Their dimensions are 10 mm wide and 200 mm long. The test strips shall be flat, without bends and burrs at the edges as well as any other mechanical defects or impurities on the test surface, which may have influence on the test results.

NOTE Test strips of brass or aluminium can be made in the same way.

6.2 Preparation of the test strips

From each new reel of strip (sold as a semi-finished product) the first several decimetres of the strip shall be rejected and then the suitable number of strip segments, each 200 mm long, shall be cut-off.

Copper strips shall be degreased with a low boiling point organic solvent (e.g. acetone or hexane) and then etched. Etching shall be carried out at laboratory temperature, with a solution of the following composition: sulphuric acid (1,82) with a mass fraction of 73 %, nitric acid (1,33) with a mass fraction of 26 %, sodium chloride with a mass fraction of 0,5 % and hard carbon black with a mass fraction of 0,5 %. The time of etching shall be between 20 s to 60 s. All strips, which are destined for one set of testing, shall be etched at the same time. The coarseness of the strip surface can be controlled by adjustment of the etching time until the copper strip has an even dull sheen. The strips shall then be washed in distilled water, then dipped in ethanol and dried with blotting paper.

NOTE Unevenness of the surface of the strip may influence the discolouration and may lead to a wrong evaluation. A surface, which is evenly dull, shows a discolouration of greater intensity than a surface, which is slightly corroded, semi-dull or brilliant.

After degreasing and etching, both ends of the strip shall be reeled loose to the shape as shown in Figure 3.

So prepared test strips shall be immediately (within 20 min) mounted in the test device, ready for the test procedure, as shown in Figure 4.

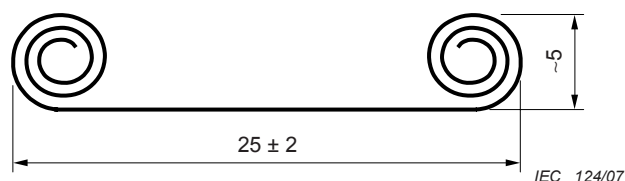

Figure 3 – Test strip

6.3 Cleanliness of test strips

After degreasing and etching, the strips should not be touched with bare hands. When handling the strips, a pair of tweezers should be used and the reeling of the ends of the test strip should be done using protective gloves.

7 Test device

The test device shall be made of materials not causing corrosion, for example of polymethylmethacrylate (Plexiglas®³). The test device shall enable simultaneous testing of all test specimens processed from one batch of insulating material (no less than five specimens).

The pressure of the test specimen onto the test strips shall be 10 N/cm². The pressure is achieved by setting a cylindrical tube (made from materials not causing corrosion) on the test specimen and filled with the appropriate amount of lead shot, to assure the desired pressure.

The recommended test device is shown in Figure 4.

³ Plexiglas® is an example of a suitable product available commercially. This information is given for the convenience of users of this document and does not constitute an endorsement by IEC of this product.

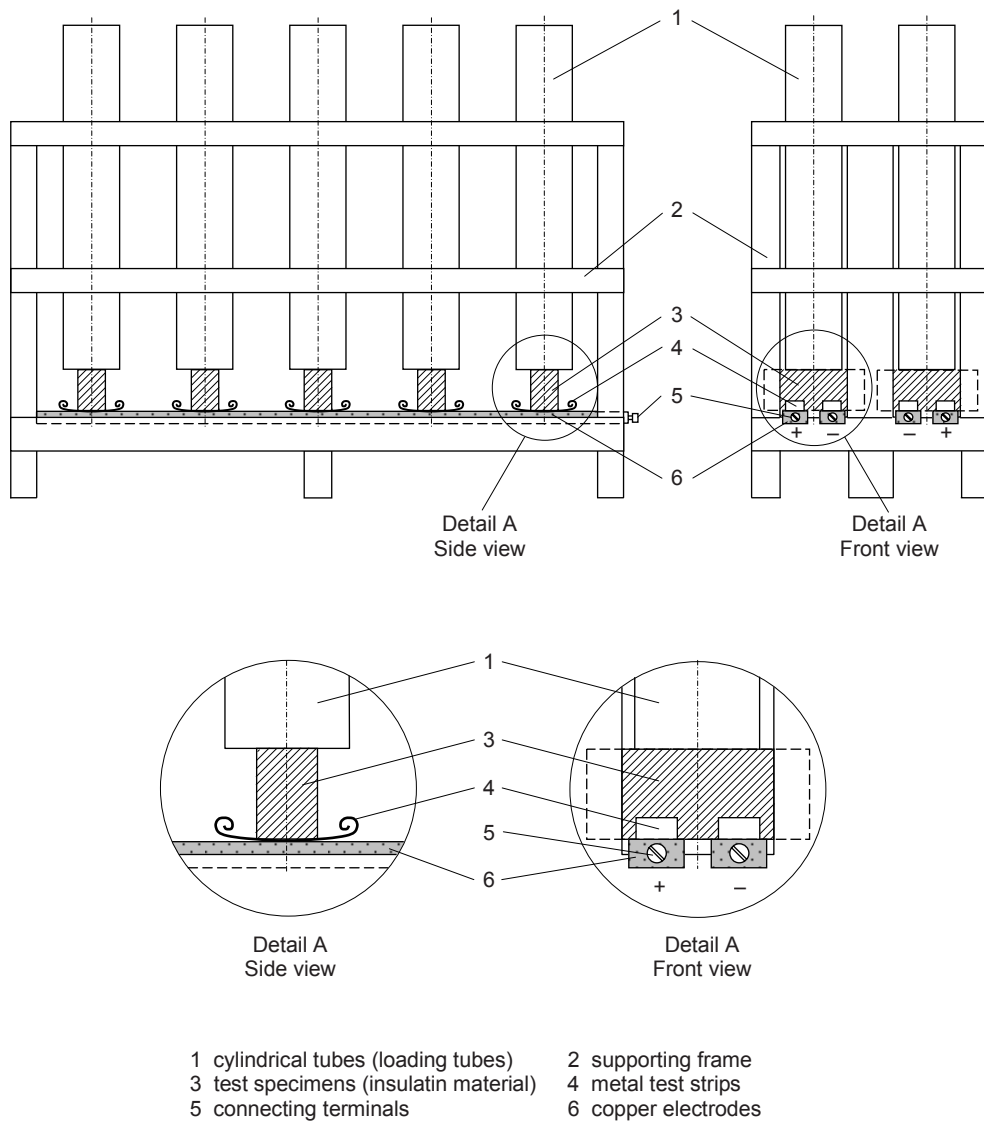

IEC 125/07

Figure 4 – Test device for determining electrolytic corrosion

Before beginning each test and mounting test specimens, the test device shall be cleaned in order to remove any corrosive residues from the previous test. Metal contacting parts shall be carefully degreased and cleaned. Other parts of the test apparatus shall be carefully wiped with a cloth dampened with ethanol.

In the test device, a cylindrical tube presses a test specimen against two adjacent copper electrodes 10 mm in width, arranged 4 mm apart. The two test strips are placed between the test surface of the specimen and along two copper electrodes, as shown in Figure 4 (Detail A).

8 Test conditions

The tests shall be carried out in a conditioning chamber under the following severities:

- temperature: $(55 \pm 1) ^\circ\text{C}$;
- relative humidity: $(93 \pm 2) \%$;
- duration of the test: $(240 \pm 2) \text{ h}$.

A direct voltage source of $(120 \pm 5) \text{ V}$, for example a dry battery, shall be used. If a rectifier is used, the permissible superimposed alternating voltage ripple may not amount to more than 1 % of the total voltage.

The methods enabling accurate temperature and humidity control have been described in IEC 60068-3-4.

9 Test procedure

The test specimens shall be placed in the test device together with the copper test strips as described in Clause 7. The copper electrodes of the device (see Figure 4) shall not be contaminated at the surfaces being in contact with the copper strips (e.g. by corrosion residues).

At least five test specimens of the same insulating material shall be mounted in the test device.

The test device with the test specimens and test strips shall be placed in the conditioning chamber. A direct voltage of $(120 \pm 5) \text{ V}$ shall be applied to the terminals of the test device for $(240 \pm 2) \text{ h}$, provided that no other time is specified in relevant specifications.

Before inserting in the conditioning chamber, the test device with the test specimens and test strips shall be heated to a temperature about $(5 \pm 1,0) \text{ K}$ higher than that of the chamber temperature, in order to prevent condensation on the surface.

During the test and at the end of the test, the applied voltage shall be measured at the terminals located on the test device (see Figure 4, Detail A, front view) to ensure that the voltage value has been maintained within the specified limits.

At the end of the test period, the voltage shall be disconnected and the test device shall be removed from the conditioning chamber and cooled to room temperature.

The test strips shall be carefully removed from the test device and examined visually and then the tensile strength shall be measured.

NOTE It is not permitted to store the test strips after the test procedure. Both visual inspection and tensile strength measurement shall be performed immediately (within 30 min) after removing test strips from the test chamber.

10 Evaluation

10.1 General evaluation

The general evaluation of the electrolytic corrosion consists of two combined estimations:

- a) visual inspection – qualitative evaluation,
- b) tensile strength measurement – quantitative evaluation.

As a first evaluation a visual inspection is carried out and then a tensile strength measurement is made on the same strip. The results of both inspections give a general evaluation of the test.

NOTE Instead of copper strips, other test metals may be used, such as brass and aluminium. The corrosion indices of evaluation for brass and aluminium strips are given in Annex A (Tables A.1 and A.2).

10.2 Visual inspection of the test strips

The strips (negative and positive) shall be examined on the side that was in direct contact with the test surface of the specimen.

The inspection of the test metal surfaces should be done (with a bare eyes or) using a magnifying glass with 5 magnifications.

The appearance of the positive and negative pole strips shall be compared to Table 1 and described in corrosion indexes given in this table. For each polarity, the symbol representing the most unfavourable corrosion index of the five strips is taken as the characteristic corrosion index of the material.

NOTE In the event of marked variations in the results obtained, the test should be repeated to discover whether preparation or execution of the test was inadequate or whether the differing results are due to inhomogeneities in the material under test.

10.3 Tensile strength of test strips

At least five samples of unexposed strips shall be tested for tensile strength to determine the comparative factor F_0 . None of the individual values obtained shall vary from the mean value by more than 2 %. If the unexposed strip fails to meet this requirement, then five additional specimens shall be tested. None of the second five tests shall vary from the mean value by more than 2 %. In case the variation is more than 2 %, the strips used for testing shall be rejected and a new reel of strip shall be used.

After exposure and visual inspection, the test strips shall be carefully unreeled. Then the tensile strength F_1 of the positive polarity test strips shall be determined in the same way as for the unexposed strips.

NOTE The measurement of tensile strength of the negative strips is a useful, but not necessary check. The decrease of tensile strength of the negative strips usually differs by not more than 1 % from the mean value of the unexposed strips.

The corrosion liability of the specimen under test is calculated as follows:

$$\text{Corrosion liability factor: } K = \frac{F_0 - F_1}{F_0} \times 100$$

where







F_0 is the tensile strength mean value of the unexposed strips;

F_1 is the tensile strength mean value of the strips with positive polarity determined after moisture and voltage exposure in the conditioning chamber.

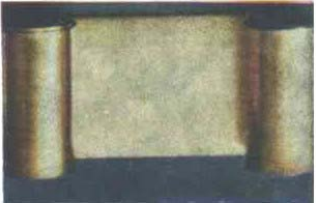
The central value of the corrosion liability factor K of the specimen tested is determined as a mean value of the tensile strength decrease by at least five positive strips, expressed in percentage. The calculated factor K is compared with the corresponding range of corrosion liability factors given in Table 1 (if needed, with the factors given in evaluation Tables A.1 and A.2, for brass and aluminium strips respectively).

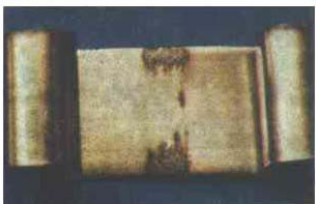
11 Evaluation of corrosion on copper strips

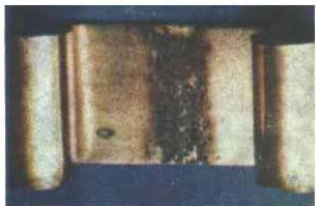
Table 1 – Degrees of corrosion of copper strips

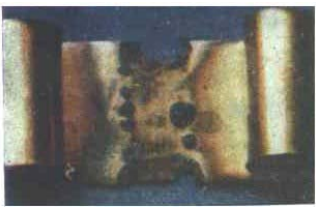
Negative pole strip			Positive pole strip			Tensile strength corrosion liability factor K %	General evaluation
Description of visual appearance	Illustration	Visual corrosion index	Description of visual appearance	Illustration	Visual corrosion index		
No change or appearance of slight ground colour on the contact surface with specimen		K 1	No change or appearance of slight ground colour on the contact surface with specimen		A 1	$K \leq 3$	Not corrosive
Dark-brown or black spots cover up to 50 % of contact surface; on the remaining no change or slight discolouration		K 2	Brown tarnish or single rose-coloured etching spots cover to 50 % of contact surface		A 2	$3 < K < 15$	Slightly corrosive
Black spots cover the whole or a prevailing part of the contact surface, as well on the other side of the strip		K 3	50 % to 100 % of contact surface covered by brown (brick-red) deposit or rosy etching spots; possible appearance of green spots		A 3	$15 < K \leq 30$	Corrosive
Intense black spots spread wide over the contact surface and on the other side of the strip; the black or brown spots may not appear on the contact surface		K 4	Total contact surface covered by thick brown deposit or deep etched (rose-coloured) or great amount of green corrosion products; possibility of cross-etching of the strip		A 4	$K > 30$	Strongly corrosive

12 Test report

The test report should include at least the following information:

- designation of the material tested (name, type and form);
- thickness and dimension of the material from which the specimens were made;
- type of the metal strip (if other than copper);
- position of test specimen in material
- test device (if other than described in Clause 7);
- the severities of the test, as described in Clause 8;
- duration of the test, as described in Clauses 8 and 9;
- number of the test specimens;
- the individual corrosion indexes (visual and tensile strength) obtained for each specimen;
- special or additional observations;
- any deviation from the conditions specified in this method;
- date of the test.

Annex A
(normative)

Tables for the evaluation of corrosion on brass and aluminium strips

Table A.1 – Degrees of corrosion of brass strips











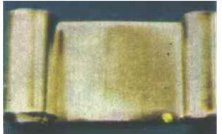

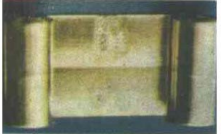

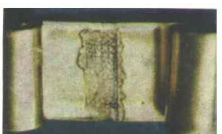
Negative pole strip			Positive pole strip			Tensile strength corrosion liability factor K %	General evaluation
Description of visual appearance	Illustration	Visual corrosion index	Description of visual appearance	Illustration	Visual corrosion index		
No change or slight discolouration		K 1	No change or appearance of slight discolouration		A 1	$K \leq 3$	Not corrosive
Dark-brown spots cover up to 50 % of contact surface		K 2	Slight red colouring (incipient dezincification) and/or brown spots cover up to 50 % of contact surface		A 2	$3 < K < 15$	Slightly corrosive
Black spots cover up to 100 % of the contact surface and possible also on the reverse side of the strip		K 3	Red colouring and possible occurrence of white deposit on 50 % to 100 % of contact surface		A 3	$15 < K \leq 30$	Corrosive
Continuous black colouring extending beyond the area of the contact surface and also on the reverse side of the strip		K 4	Strong red colouring (advanced dezincification) on total contact surface and possible occurrence of white or black deposit		A 4	$K > 30$	Strongly corrosive

Table A.2 – Degrees of corrosion of aluminium strips

Negative pole strip			Positive pole strip			Tensile strength corrosion liability factor K %	General evaluation
Description of visual appearance	Illustration	Visual corrosion index	Description of visual appearance	Illustration	Visual corrosion index		
No change		K 1	No change		A 1	$K \leq 3$	Not corrosive
White spots cover predominating part of contact area		K 2	Slight etching in form of white spots or white deposit cover up to 50 % of the contact surface		A 2	$3 < K < 15$	Slightly corrosive
Thin white deposit on whole contact area, which may extend beyond this area and also on the reverse side of the strip		K 3	Predominating part of contact surface area covered by white deposit of corrosion products of aluminium and single pitting holes		A 3	$15 < K \leq 30$	Corrosive
Thick white deposit of corrosion products of aluminium covers the whole area of contact surface extending far beyond this area. On the reverse side great white spots and thick white deposit		K 4	The whole area of the contact surface is covered by thick white deposit of corrosion products of aluminium also extending beyond the contact area and a great number of deep pitting, some penetrating the strip		A 4	$K > 30$	Strongly corrosive

Annex B (informative)

Notes on visual evaluation

If slight electrolytic corrosion occurs with non-ferrous metals, discolourations appear; on brass for example, brown, black or red (dezincification). In the case of heavy electrolytic corrosion, green discolourations appear at the positive pole. These green discolourations are more dangerous because they indicate electrolytic erosion of the metal at the positive pole which, in the case of wires in coils for instance, initiates destruction as a result of reduction in diameter.

The cut edges of laminates and other insulating materials usually produce more corrosion than the moulded surface of such materials with its high resin content or the surface obtained by varnishing or coating with better insulating materials. This indicates that embedded paper or fabrics, glass mats, wood flour and other fillers can also be responsible for the process of electrolysis. The test method thus makes primary provision that the cut edge of the insulating materials be used as the test surface. To ensure that, as far as possible, all embedded materials are included in the test of the cut surfaces, the test face should be made smooth and flat, by milling for example. If cut by scissors, the test variability caused by the resultant rough edges of the test specimens would be too great.

As impurities such as chlorine ions produced by perspiration assist electrolytic processes, the testing surfaces should not be touched with the fingers after preparing the specimens.

Further treatment can also reduce the surface quality of insulating materials in respect to the process of electrolysis. To permit a description of the quality of the surface, if necessary, particulars relating to the test of the surface have also been included in the method.

In the test, electrolysis occurs on strips placed between test specimen and electrodes. These test strips must have an absolutely plane, clean, semi-gloss surface free from any burrs. Strips, which are crumpled or have burrs (from cutting) will produce a false impression of corrosion. After cleaning, the strips, like the test specimens, should not be touched with the bare hands. It is therefore advisable to use tweezers when placing the strips in position. The method of cleaning the strips is also important. To avoid faulty evaluations and misunderstandings, as far as possible, a special procedure is described for cleaning the strips, after these have first been degreased thoroughly. It is always advisable to clean a large number of strips and then to store them in a desiccator. Any condensation on the test specimens should be avoided since otherwise the action of a dripping liquid could result in much heavier electrolysis, leading to a poor evaluation of the material.

Annex C (informative)

Copper wire tensile strength method

C.1 Principle of the method

The test consists of applying, under specified conditions, a direct current potential difference to two parallel copper wires 6 mm apart, serving as the anode and the cathode respectively and placed on the surface of the material under test. In order to obtain a good contact between the wires and the material under test, and to ensure parallelism of the wires, the test surfaces are cylindrical.

The effect of electrolytic corrosion is assessed by measurement of tensile strength of the copper wires.

C.2 Test specimens

The following clauses give an overview on different test specimen.

C.2.1 Shape

C.2.1.1 General

The shapes of the specimens are a function of the type of material and the form in which it is supplied.

C.2.1.2 Semi-finished materials (blocks, sheets) or moulded parts (compression mouldings, injection mouldings, castings, etc.)

The specimens shall be tested in the form of disks or rods, preferably 50 mm in diameter and 12 mm to 75 mm thick. Products thinner than 12 mm (e.g. thin laminates) may be laminated and held together under pressure. Very thin, flexible laminates (usually 0,25 mm or less) shall be tested in the same way as films (see C.2.1.3).

The edge of the disk constitutes the active test area. It may be tested as moulded, or cast or the surface may be machined dry without the use of any lubricant or cutting oil unless the effect of such lubricant is to be investigated. When thin materials are to be laminated together, care shall be taken to prevent burring of individual edges. Such thin materials may often be machined to final form while held together under bolting pressure.

C.2.1.3 Films and thin sheets, including varnished papers and adhesive tapes

The test specimens shall be in the form of strips 150 mm long and 12 mm to 75 mm wide. Materials wider than 75 mm should be cut to a width of 75 mm. For materials supplied in roll form, the three outer layers of the roll should be discarded. Great care shall be taken to avoid contamination during cutting, using a clean blade or scissors. When testing film materials, it is permissible to build up the required diameter of test specimen in the form of a tightly-wound roll.

C.2.1.4 Sleeving and tubing

Sleeving and tubing (both varnished fabric and extruded) are cut into specimens 150 mm long. When flattened, the sleeving shall be at least 12 mm wide. If specified, the sleeving or

tubing shall be slit along its length and opened up to form a tape, which shall also be at least 12 mm wide.

Alternatively, sleeving may be tested in its tubular form by threading the copper wire through the sleeving and applying voltage between the wire and a copper foil fitted to the cylindrical surface of either the large or small test apparatus.

C.2.1.5 Lacquers and insulating varnishes

Lacquers and varnishes, which dry at room or at low temperatures, shall be applied to the circular surface of borosilicate glass tubes or polymethylmethacrylate rods 50 mm in diameter and 75 mm long or longer if the corrosive effect of the base material is to be avoided. Machined disks 50 mm in diameter and 12 mm thick or thicker may also be used. Varnishes, which cure at relatively high temperatures shall be applied to the curved surface of a borosilicate glass tube 50 mm in diameter and 75 mm long or to rods cast from an unfilled epoxy resin known to induce little or no electrolytic corrosion in themselves as determined by this test. The epoxy rod may also be more suitable for coating materials which contain solvents which attack polymethylmethacrylate.

Lacquers and varnishes may also be evaluated when applied to other substrates as specified. For example, varnishes may be evaluated after application to woven tape. In such cases, the test sample shall conform to C.2.1.3.

C.2.2 Cleanliness of the testing surfaces

When preparing and handling the test specimens, any soiling of the testing surfaces shall be avoided, for example by perspiration from the hands. The specimens shall be touched only with a pair of tweezers or with protecting gloves made of materials free from corrosion (e.g. polyethylene).

C.2.3 Number of test specimens

At least five specimens shall be tested and used for the determination of the control value. If considerable variability is encountered, ten or more test specimens are recommended.

C.3 Test apparatus

C.3.1 General

Two types of apparatus exist:

- small apparatus for testing the specimens described in C.2.1.2, C.2.1.4 and C.2.1.5;
- large apparatus for testing the specimens described in C.2.1.3 and C.2.1.4.

C.3.2 Small apparatus

The 50 mm diameter disks of the material to be tested are assembled by means of a stainless steel (or brass) bolt through the centre of the disks and stainless steel (or brass) end washers as shown in Figure C.1. The through-bolt is held in a horizontal position by a stainless steel (or nickel-plated brass) framework which also carries two rows of ceramic stand-off insulators parallel to the bolt. The insulators of each row are spaced 6 mm apart. Phosphor bronze leaf springs are soldered horizontally to the insulators of one row so that the two test wires (see C.3.3) for each test specimen will make contact with half the circumference of the disks and will be 6 mm apart. Phosphor bronze leaf springs are attached to the opposite insulator in positions, which correspond to the soldering tags on the other insulator. The leaf springs should deflect at least 3 mm for a 0,5 N load.

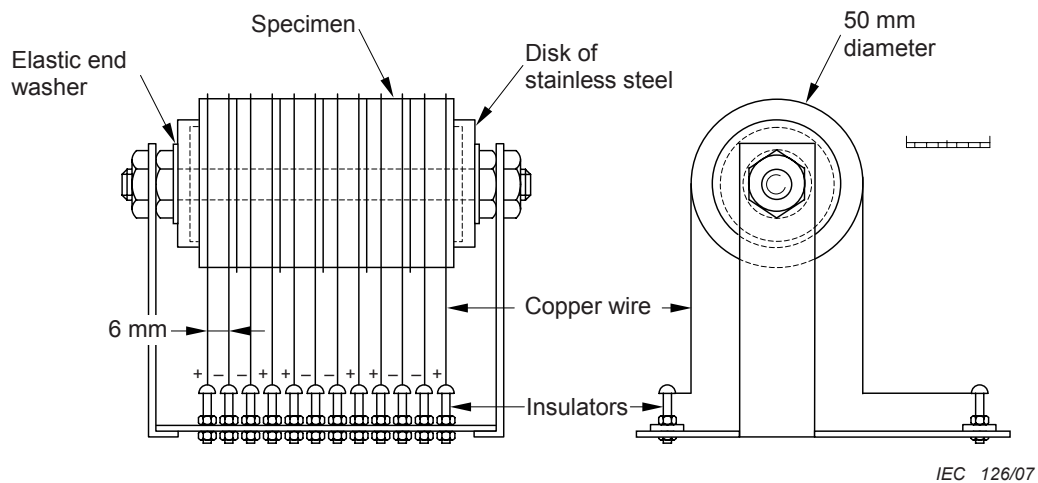

Figure C.1 – Apparatus for determining electrolytic corrosion of rigid insulating material

C.3.3 Large apparatus

The apparatus (see Figure C.2) which carries the flexible test specimens consists of a borosilicate glass tube approximately 330 mm long and approximately 90 mm in diameter suitably secured at both ends to a stainless steel (or nickel-plated brass) frame. The frame supports the glass tube in a horizontal position and also holds two electrical quality porcelain insulating strips parallel to, below and on both sides, of the axis of the glass tube. Soldering tags (tabs) and leaf springs are attached to the insulating strips as described in C.3.2 above.

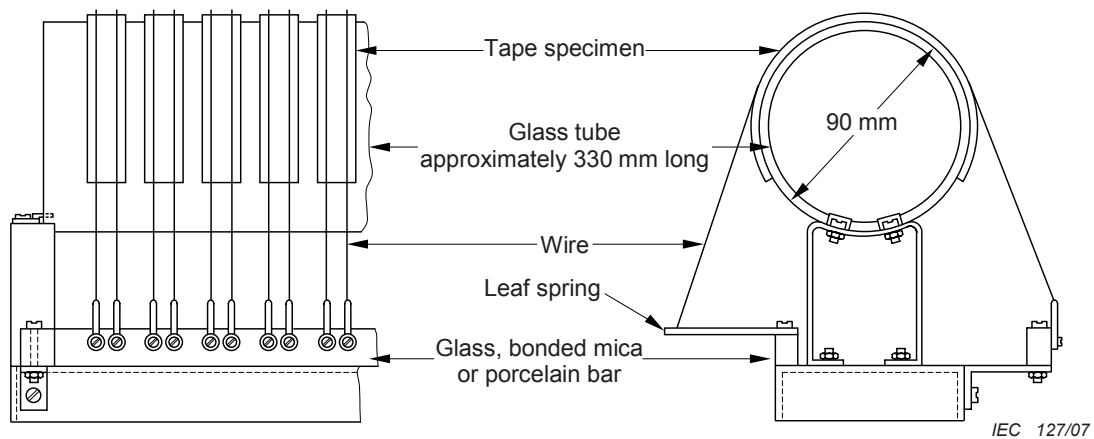

Figure C.2 – Apparatus for determining electrolytic corrosion of flexible insulating material

C.3.4 Test wires

Lengths of bare electrolytically refined copper wire in the annealed state 0,2 mm in diameter shall be cut about 380 mm long to serve as anodes and cathodes in the test and to provide specimens for determining the strength of untested wire. The wire shall be smooth, straight and free from kinks or other defects. For tests on one material, all of the wire shall be cut from the same spool.

C.3.5 Cleaning of apparatus and test wires

Before each test, the test apparatus shall be cleaned so as to remove any corrosive residues from previous tests before the test specimens are mounted. Metal parts shall be carefully degreased and thoroughly cleaned by rinsing in hot tap water and then distilled water. Finally they shall be carefully wiped with a polyamide fabric cloth dampened with pure, clean methanol. The glass tube shall be cleaned by thorough rinsing in hot tap water and finally in distilled water and wiped with a clean cloth.

The test wires shall be carefully wiped with a polyamide fabric dampened with a low boiling, pure hydrocarbon solvent (such as hexane) to remove winding oil, if present. The test wires shall finally be cleaned with clean polyamide fabric dampened with pure methanol.

C.3.6 Tensile test equipment

To determine the tensile strength of the test wires, a standard tensile strength testing machine for wire shall be used, preferably with a constant rate of traverse and a total load capability of about 10 N with a readable accuracy of at least 0,05 N. The rate of traverse shall be maintained constant from test to test at approximately 125 mm per minute.

C.3.7 Test conditions

The tests shall be carried out in a conditioning chamber. Three conditioning treatments are recommended for electrolytic corrosion tests and the specifications for individual materials shall state which of the following three conditions is to be employed and for how long the specimen shall be exposed:

- (23 ± 2) °C; (93 ± 2) % relative humidity
- (40 ± 2) °C; (93 ± 2) % relative humidity
- (55 ± 0,5) °C; (93 ± 1) % relative humidity

When it is inserted, the specimen shall be at a higher temperature than the chamber so as to prevent surface condensation; about 5 °C above the chamber temperature will normally be found suitable.

C.3.8 Power supply

A direct voltage source, for example a dry battery, of (240 ± 5) V is used. A resistor of 4 700 Ω is inserted in series with each test specimen to limit the short-circuit current.

C.4 Test procedure

C.4.1 Assembly of test specimen

Rigid test specimens shall be bolted together and supported in the test frame with a through-bolt and end-washers, so as to make a rod about 75 mm long.

Flexible test specimens shall be assembled circumferentially on the upper surface of the glass tube. The ends of the test material should be anchored to the glass tube with small pieces of pressure-sensitive adhesive tape, which is known not to induce electrolytic corrosion. If the test specimen has a different character on either side, then separate tests shall be made on either side.

C.4.2 Assembly of test wires

Each length of test wire shall be soldered to the appropriate tag using only resin soldering flux (excess soldering flux shall be removed with methanol). A tension of approximately 0,5 N shall be applied to the test wire using a suitable tension gauge, as it is positioned over the surface of the test specimen. The other end of the test wire shall then be soldered to a spring which has been deflected so as to maintain the 0,5 N tension in the wire. After the first wire is attached, a second wire is fastened in a similar fashion and positioned over the test specimen so that it is parallel to and uniformly spaced 6 mm from the first wire along the entire length with which it is in contact with the test specimen. A suitable spacer may be used for making small adjustments in the positioning of the wires, but great care shall be taken to avoid contamination or mechanical injury to the wire.

C.4.3 Voltage and humidity exposure

The test device shall be heated to a temperature about 5 °C higher than the chamber temperature (see C.3.7) and then placed in the conditioning chamber. The test voltage (240 ± 5) V shall then be applied to the terminals in such a manner that adjacent wires of adjacent specimens are at the same potential. If not otherwise specified, the exposure period shall be 4 or 15 days.

At the end of the test, the applied voltage shall be measured at the terminal remote from the terminal to which it is applied to ensure that the voltage has been maintained within the specified limits.

C.4.4 Tensile strength of test wires

At least ten samples of unexposed wires shall be tested for tensile strength. None of the individual values shall vary from the mean by more than ±1 %. If the unexposed wire fails to meet this requirement, then ten additional specimens shall be tested. None of the second ten tests shall vary from the mean by more than +1 %. The mean value of the breaking load for unexposed wire shall be in the range of 8 N to 9 N.

After exposure, the wire shall be first examined for changes in colour and appearance, then cut off at the soldering tags and carefully removed from the test assembly. The wire with positive polarity shall be examined carefully for pitting or other evidence of corrosion and then the tensile strength shall be determined in the same way as for the unexposed wires.

The specimen itself shall also be examined for discolouration, note being taken of whether this is in a continuous line or only in spots.

NOTE The measurement of the tensile strength of the negative wires is a useful check. The decrease of tensile strength of the negative wires usually differs by not more than 0,5 % from the mean value of the unexposed wires.

C.5 Evaluation

The corrosion liability of the specimen under test is calculated as follows:

$$\text{Corrosion liability factor: } K = \frac{F_0 - F_1}{F_0} \times 100$$

where

F_0 is the tensile strength mean value of the unexposed wire;

F_1 is the tensile strength mean value of the wire with positive polarity determined after moisture and voltage exposure.

The central value of the corrosion liability factor should be determined.

C.6 Test report

The test report should include at least the following information:

- designation of the product;
 - type of the product;
 - shape of the test specimen: cylindrical disk or flexible sheet;
 - initial thickness of product and number of laminations (if any) used in the test specimen;
 - any deviations from the conditions or procedures described herein;
 - visual appearance of specimens and test wires at the conclusion of test;
 - degree of pitting in the test wire with positive polarity;
 - individual values and central value of the tensile strength for unexposed test wires;
 - speed of jaw separation in the tensile test;
 - individual values and central value of the calculated corrosion liability factor;
 - special or additional observations;
 - date of the test.
-

Annex ZA
(normative)**Normative references to international publications
with their corresponding European publications**

The following referenced documents are indispensable for the application of this document. For dated references, only the edition cited applies. For undated references, the latest edition of the referenced document (including any amendments) applies.

NOTE When an international publication has been modified by common modifications, indicated by (mod), the relevant EN/HD applies.

<u>Publication</u>	<u>Year</u>	<u>Title</u>	<u>EN/HD</u>	<u>Year</u>
IEC 60068-3-4	2001	Environmental testing – Part 3-4: Supporting documentation and guidance - Damp heat tests	EN 60068-3-4	2002
IEC 60454-2	- ¹⁾	Specifications for pressure-sensitive adhesive - tapes for electrical purposes – Part 2: Methods of test		-

¹⁾ At draft stage.

BSI — British Standards Institution

BSI is the independent national body responsible for preparing British Standards. It presents the UK view on standards in Europe and at the international level. It is incorporated by Royal Charter.

Revisions

British Standards are updated by amendment or revision. Users of British Standards should make sure that they possess the latest amendments or editions.

It is the constant aim of BSI to improve the quality of our products and services. We would be grateful if anyone finding an inaccuracy or ambiguity while using this British Standard would inform the Secretary of the technical committee responsible, the identity of which can be found on the inside front cover.
Tel: +44 (0)20 8996 9000. Fax: +44 (0)20 8996 7400.

BSI offers members an individual updating service called PLUS which ensures that subscribers automatically receive the latest editions of standards.

Buying standards

Orders for all BSI, international and foreign standards publications should be addressed to Customer Services. Tel: +44 (0)20 8996 9001.
Fax: +44 (0)20 8996 7001. Email: orders@bsi-global.com. Standards are also available from the BSI website at <http://www.bsi-global.com>.

In response to orders for international standards, it is BSI policy to supply the BSI implementation of those that have been published as British Standards, unless otherwise requested.

Information on standards

BSI provides a wide range of information on national, European and international standards through its Library and its Technical Help to Exporters Service. Various BSI electronic information services are also available which give details on all its products and services. Contact the Information Centre.
Tel: +44 (0)20 8996 7111. Fax: +44 (0)20 8996 7048. Email: info@bsi-global.com.

Subscribing members of BSI are kept up to date with standards developments and receive substantial discounts on the purchase price of standards. For details of these and other benefits contact Membership Administration.
Tel: +44 (0)20 8996 7002. Fax: +44 (0)20 8996 7001.
Email: membership@bsi-global.com.

Information regarding online access to British Standards via British Standards Online can be found at <http://www.bsi-global.com/bsonline>.

Further information about BSI is available on the BSI website at <http://www.bsi-global.com>.

Copyright

Copyright subsists in all BSI publications. BSI also holds the copyright, in the UK, of the publications of the international standardization bodies. Except as permitted under the Copyright, Designs and Patents Act 1988 no extract may be reproduced, stored in a retrieval system or transmitted in any form or by any means – electronic, photocopying, recording or otherwise – without prior written permission from BSI.

This does not preclude the free use, in the course of implementing the standard, of necessary details such as symbols, and size, type or grade designations. If these details are to be used for any other purpose than implementation then the prior written permission of BSI must be obtained.

Details and advice can be obtained from the Copyright & Licensing Manager.
Tel: +44 (0)20 8996 7070. Fax: +44 (0)20 8996 7553.
Email: copyright@bsi-global.com.