

Household and similar electrical appliances — Safety —

**Part 2-75: Particular requirements for
commercial dispensing appliances and
vending machines**

ICS 55.230; 97.030

National foreword

This British Standard is the UK implementation of EN 60335-2-75:2004+A1:2005, incorporating A11:2006 and A12:2010. It is identical with IEC 60335-2-75:2002, Edition 2.1:2005, which comprises Edition 2:2002 consolidated by the incorporation of amendment 1:2004. It supersedes BS EN 60335-2-63:1993, BS EN 60335-2-75:2002 and BS EN 60335-2-75:2004 which are withdrawn.

The start and finish of text introduced or altered by amendment is indicated in the text by tags **A1** **A1**. Tags indicating changes to IEC text carry the number of the IEC amendment. For example, text altered by IEC amendment A1 is indicated by **A1** **A1**.

The CENELEC common modifications have been implemented at the appropriate places in the text. The start and finish of each common modification is indicated in the text by tags **C** **C**. Where a common modification has been introduced by amendment, the tags carry the number of the amendment. For example, the common modifications introduced by CENELEC amendment A11 are indicated by **C11** **C11**.

The UK participation in its preparation was entrusted by Technical Committee CPL/61, Safety of household and similar electrical appliances, to Subcommittee CPL/61/5, Commercial catering equipment.

A list of organizations represented on this Subcommittee can be obtained on request to its secretary.

This publication does not purport to include all the necessary provisions of a contract. Users are responsible for its correct application.

Compliance with a British Standard cannot confer immunity from legal obligations.

This British Standard was published under the authority of the Standards Policy and Strategy Committee on 24 September 2004

© BSI 2010

Amendments/corrigenda issued since publication

Amd. No.	Date	Comments
15629	25 May 2005	Implementation of IEC amendment 1:2004 with CENELEC endorsement A1:2005
16913	28 February 2007	Implementation of CENELEC amendment A11:2006
	31 July 2010	Implementation of CENELEC amendment A12:2010

EUROPEAN STANDARD

NORME EUROPÉENNE

EUROPÄISCHE NORM

EN 60335-2-75:2004+A1

February 2005

+ A11

August 2006

+ A12

January 2010

ICS 55.230

Supersedes EN 60335-2-63:1993 and EN 60335-2-75:2002

English version

**Household and similar electrical appliances –
Safety
Part 2-75: Particular requirements for commercial
dispensing appliances and vending machines**

Appareils électrodomestiques et analogues –
Sécurité
Partie 2-75: Règles particulières
pour les distributeurs commerciaux
avec ou sans moyen de paiement

Sicherheit elektrischer Geräte für den
Hausgebrauch und ähnliche Zwecke
Teil 2-75: Besondere Anforderungen
für Ausgabegeräte und Warenautomaten für
den gewerblichen Gebrauch

This European Standard was approved by CENELEC on 2004-03-01. CENELEC members are bound to comply with the CEN/CENELEC Internal Regulations which stipulate the conditions for giving this European Standard the status of a national standard without any alteration.

Up-to-date lists and bibliographical references concerning such national standards may be obtained on application to the Central Secretariat or to any CENELEC member.

This European Standard exists in three official versions (English, French, German). A version in any other language made by translation under the responsibility of a CENELEC member into its own language and notified to the Central Secretariat has the same status as the official versions.

CENELEC members are the national electrotechnical committees of Austria, Belgium, Cyprus, Czech Republic, Denmark, Estonia, Finland, France, Germany, Greece, Hungary, Iceland, Ireland, Italy, Latvia, Lithuania, Luxembourg, Malta, Netherlands, Norway, Poland, Portugal, Slovakia, Slovenia, Spain, Sweden, Switzerland and United Kingdom.

CENELEC

European Committee for Electrotechnical Standardization
Comité Européen de Normalisation Electrotechnique
Europäisches Komitee für Elektrotechnische Normung

Central Secretariat: rue de Stassart 35, B - 1050 Brussels

Foreword

The text of the International Standard IEC 60335-2-75:2002, prepared by the IEC Technical Committee 61, together with the common modifications prepared by CENELEC TC 61, was submitted to the Unique Acceptance Procedure and was approved by CENELEC as EN 60335-2-75 on 2004-03-01.

This European Standard replaces EN 60335-2-63:1993 and EN 60335-2-75:2002.

The following dates are applicable:

- latest date by which the EN has to be implemented
at national level by publication of an identical
national standard or by endorsement (dop) 2005-03-01
- date on which the national standards conflicting
with the EN have to be withdrawn (dow) 2007-03-01

This part 2 has to be used in conjunction with EN 60335-1, Household and similar electrical appliances – Safety – Part 1: General requirements. It was established on the basis of the 2002 edition of that standard. Amendments and revisions of Part 1 have also to be taken into account and the dates when such changes become applicable will be stated in the relevant amendment or revision of Part 1.

This part 2 supplements or modifies the corresponding clauses of EN 60335-1, so as to convert it into the European Standard: Safety requirements for commercial electric dispensing appliances and vending machines.

When a particular subclause of Part 1 is not mentioned in this part 2, that subclause applies as far as is reasonable. When this standard states "addition", "modification" or "replacement", the relevant text of Part 1 is to be adapted accordingly.

NOTE 1 The following numbering system is used:

- subclauses, tables and figures that are numbered starting from 101 are additional to those in Part 1;
- unless notes are in a new subclause or involve notes in Part 1, they are numbered starting from 101, including those in a replaced clause or subclause;
- additional annexes are lettered AA, BB, etc.;
- subclauses, notes and annexes that are additional to those in the IEC standard are prefixed with the letter Z.

NOTE 2 The following print types are used:

- requirements: in roman type;
- *test specifications: in italic type;*
- notes: in small roman type.

Words in **bold** in the text are defined in Clause 3. When a definition concerns an adjective, the adjective and the associated noun are also in bold.

There are no special national conditions causing a deviation from this European Standard, other than those listed in Annex ZA to EN 60335-1.

There are no national deviations from this European Standard, other than those listed in Annex ZB to EN 60335-1.

Introduction

An investigation by CENELEC TC 61 has shown that all risks from products within the scope of this standard are fully covered by the Low Voltage Directive, 73/23/EEC. For products having mechanical moving parts, a risk assessment in accordance with the Machinery Directive, 98/37/EC, has shown that the risks are mainly of electrical origin and consequently this directive is not applicable. However, the relevant essential safety requirements of the Machinery Directive are covered by this standard together with the principal objectives of the Low Voltage Directive.

Endorsement notice

The text of the international Standard IEC 60335-2-75:2002 was approved by CENELEC as a European Standard with agreed common modifications.

Foreword to amendment A1

The text of document 61/2743/FDIS, future amendment 1 to IEC 60335-2-75:2002, prepared by the IEC Technical Committee 61, Safety of household and similar electrical appliances, was submitted to the IEC-CENELEC parallel vote and was approved by CENELEC as amendment A1 to EN 60335-2-75:2004 on 2004-12-01.

The following dates are applicable:

- latest date by which the amendment has to be implemented at national level by publication of an identical national standard or by endorsement (dop) 2005-09-01
- date on which national standards conflicting with the amendment have to be withdrawn (dow) 2007-12-01

This amendment supplements or modifies the corresponding clauses of EN 60335-2-75:2004.

There are no special national conditions causing a deviation from this amendment.

There are no national deviations from this amendment.

Endorsement notice

The text of amendment 1:2004 to the International Standard IEC 60335-2-75:2002 was approved by CENELEC as an amendment to the European Standard without any modification.

Foreword to amendment A11

When discussing the comments received during the voting procedure for prEN 60335-2-75 at the Balsthal meeting of CENELEC TC 61 in June 2004, the Italian national committee was asked to prepare a firm proposal for an amendment to be submitted to the Unique Acceptance Procedure. This proposal, document CENELEC/TC 61/IT0264/NP, was discussed during the Milan meeting of CENELEC TC 61 in November 2004 and was accepted for circulation as a draft amendment.

The draft was circulated in April 2005 and was approved by CENELEC as amendment A11 to EN 60335-2-75:2004 on 2005-12-06.

The following dates are applicable:

- latest date by which the amendment has to be implemented at national level by publication of an identical national standard or by endorsement (dop) 2006-12-01
- date on which national standards conflicting with the amendment have to be withdrawn (dow) 2006-12-01

This amendment supplements or modifies the corresponding clauses of EN 60335-2-75:2004.

There are no special national conditions causing a deviation from this amendment.

There are no national deviations from this amendment.

Foreword to amendment A12

This amendment to the European Standard EN 60335-2-75:2004 was prepared by the Technical Committee CENELEC TC 61, Safety of household and similar electrical appliances.

A proposal for this amendment was discussed during the Kista meeting of CENELEC TC 61 in June 2008, when it was decided to submit a draft for an amendment to the Unique Acceptance Procedure.

The draft was circulated in November 2008 and was approved by CENELEC as amendment A12 to EN 60335-2-75:2004 on 2009-11-01.

Attention is drawn to the possibility that some of the elements of this document may be the subject of patent rights. CEN and CENELEC shall not be held responsible for identifying any or all such patent rights.

The following dates were fixed:

- latest date by which the amendment has to be implemented
at national level by publication of an identical
national standard or by endorsement (dop) 2010-11-01

 - latest date by which the national standards conflicting
with the amendment have to be withdrawn (dow) 2010-11-01
-

CONTENTS

INTRODUCTION.....	6
1 Scope	7
2 Normative references	8
3 Definitions	8
4 General requirement.....	10
5 General conditions for the tests	10
6 Classification.....	11
7 Marking and instructions	11
8 Protection against access to live parts	14
9 Starting of motor-operated appliances.....	14
10 Power input and current.....	14
11 Heating	14
12 Void	15
13 Leakage current and electric strength at operating temperature	15
14 Transient overvoltages	16
15 Moisture resistance	16
16 Leakage current and electric strength	19
17 Overload protection of transformers and associated circuits	19
18 Endurance.....	19
19 Abnormal operation	19
20 Stability and mechanical hazards	21
21 Mechanical strength	21
22 Construction.....	21
23 Internal wiring.....	24
24 Components.....	25
25 Supply connection and external flexible cords	26
26 Terminals for external conductors	26
27 Provision for earthing.....	26
28 Screws and connections	26
29 Clearances, creepage distances and solid insulation	27
30 Resistance to heat and fire	27
31 Resistance to rusting	27
32 Radiation, toxicity and similar hazards	27
 Annexes	 29
Annex AA (normative) Aging test for elastomeric parts.....	29
Bibliography	31
 Figure 101 – Splash apparatus.....	 28

INTRODUCTION

It has been assumed in the drafting of this International Standard that the execution of its provisions is entrusted to appropriately qualified and experienced persons.

This standard recognizes the internationally accepted level of protection against hazards such as electrical, mechanical, thermal, fire and radiation of appliances when operated as in normal use taking into account the manufacturer's instructions. It also covers abnormal situations that can be expected in practice and takes into account the way in which electromagnetic phenomena can affect the safe operation of appliances.

This standard takes into account the requirements of IEC 60364 as far as possible so that there is compatibility with the wiring rules when the appliance is connected to the supply mains. However, national wiring rules may differ.

If an appliance within the scope of this standard also incorporates functions that are covered by another part 2 of IEC 60335, the relevant part 2 is applied to each function separately, as far as is reasonable. If applicable, the influence of one function on the other is taken into account.

This standard is a product family standard dealing with the safety of appliances and takes precedence over horizontal and generic standards covering the same subject.

An appliance that complies with the text of this standard will not necessarily be considered to comply with the safety principles of the standard if, when examined and tested, it is found to have other features that impair the level of safety covered by these requirements.

An appliance employing materials or having forms of construction differing from those detailed in the requirements of this standard may be examined and tested according to the intent of the requirements and, if found to be substantially equivalent, may be considered to comply with the standard.

HOUSEHOLD AND SIMILAR ELECTRICAL APPLIANCES – SAFETY –

Part 2-75: Particular requirements for commercial dispensing appliances and vending machines

1 Scope

This clause of Part 1 is replaced by the following.

This International Standard deals with the safety of electric commercial **dispensing appliances** and **vending machines** for preparation or delivery of food, drinks and consumer products, their **rated voltage** being not more than 250 V for single-phase appliances and 480 V for other appliances.

NOTE 101 Examples of appliances that are within the scope of this standard are

- bulk tea or coffee brewing machines;
- cigarette **vending machines**;
- coffee grinders **(A1)**;
- commercial liquid heaters;
- espresso coffee appliances;
- hot and cold beverage **vending machines**;
- hot water **dispensers**;
- ice cream and whipped cream **dispensers**;
- ice **dispensers**;
- newspaper, audio or video tape or disc **vending machines**;
- packaged food and drink **vending machines**;
- refrigerated merchandisers

Appliances may have more than one function.

NOTE 102 Other standards may be applicable for some functions such as

- refrigeration (IEC 60335-2-24);
- heating by microwaves (IEC 60335-2-25);
- coffee grinding (IEC 60335-2-64).

(A1) This standard also deals with the hygiene aspects of appliances. **(A1)**

As far as is practicable, this standard deals with the common hazards presented by appliances that are encountered by users and **maintenance persons**. However, in general, it does not take into account young children playing with the appliance.

NOTE 103 Attention is drawn to the fact that

- for appliances intended to be used in vehicles or on board ships or aircraft, additional requirements may be necessary;
- in many countries, additional requirements for appliances incorporating pressure vessels are specified;
- in many countries, additional requirements are specified by the national health authorities, the national authorities responsible for the protection of labour, the national water supply authorities and similar authorities.

NOTE 104 This standard does not apply to

- appliances intended to be used exclusively for household purposes;
- appliances intended to be used exclusively for industrial purposes;
- appliances intended to be used in locations where special conditions prevail, such as the presence of a corrosive or explosive atmosphere (dust, vapour or gas);
- commercial electric boiling pans (IEC 60335-2-47);

- commercial electric bains-marie (IEC 60335-2-50);
- amusement machines and personal service machines (IEC 60335-2-82);
- appliances solely used for dispensing money;
- display cabinets;
- appliances incorporating electrode-type water heaters.

2 Normative references

This clause of Part 1 is applicable except as follows.

Addition:

IEC 60335-2-34, *Safety of household and similar electrical appliances – Part 2-34: Particular requirements for motor-compressors*

ISO 1817:1999, *Rubber, vulcanized – Determination of the effect of liquids*

3 Definitions

This clause of Part 1 is applicable except as follows.

3.1.9 Replacement:

normal operation

operation of the appliance under the following conditions

The appliance is operated in the **standby mode** until steady conditions are established and then under the most unfavourable dispensing procedure. The appliance is refilled when necessary in accordance with the instructions for use, or the **instructions for maintenance**, and the next operating period started as soon as possible.

Lids and covers of **appliances of the professional type** and of **appliances of the supervised type** are placed in their intended positions.

3.6.2 Replacement:

detachable part

part that can be removed without the aid of a **tool**, a part that is removed in accordance with the instructions for use or the **instructions for maintenance**, even if a **tool** or **access key** is needed for removal, or a part that does not fulfill the test of 22.11

NOTE 101 If a part has to be removed for installation purposes, this part is not considered to be detachable even if the instructions state that it is to be removed.

NOTE 102 A part that can be opened is considered to be a part that can be removed.

3.7.3 Replacement:

thermal cut-out

device that during abnormal operation limits the temperature of the controlled part by automatically opening the circuit, or reducing the current, and is constructed so that its setting cannot be altered by the user or the **maintenance person**

3.8.5 Replacement:

Ⓐ maintenance operation

operation performed in the **maintenance area** or **user area**, such as preparing the appliance for new products or new operating methods, cleaning, price changing, replenishing, coin collecting and setting of controls or similar operations

NOTE 101 **Maintenance operation** does not include operations performed in the **service area**. Ⓐ

3.101**rated pressure**

pressure assigned to the pressurized parts of the appliance by the manufacturer

3.102**standby mode**

appliance filled as intended with ingredients or products, energized and ready for use, cash boxes and overflow containers being empty

3.103**access key**

key or other means that gives access to the **maintenance area** but does not give access to the **service area**

NOTE "Other means" includes a **tool** or operation by codes or signals produced by optical or electromagnetic sources.

3.104**override key**

key or other means that is used to render an interlock inoperative

3.105**dispensing appliance**

appliance intended to deliver or make available food, drinks or other consumer products

NOTE 1 The appliance may also prepare the products.

NOTE 2 The dispensing operation may be initiated manually or by means such as coins or credit cards.

3.106**vending machine**

dispensing appliance that is operated by coins, credit cards or other means of payment

3.107**instructions for maintenance**

instructions explaining how to carry out cleaning, replenishing, coin collecting, setting of controls and similar operations

3.108**maintenance person**

person who maintains the appliance in accordance with the **instructions for maintenance**

3.109**user area**

area where access is gained without the use of an **access key** or a **tool**

NOTE 1 The **user area** of **appliances of the supervised type** is determined with **detachable parts** and other movable parts, such as doors and lids, in position as in normal use.

NOTE 2 **Appliances of the professional type** have no **user area**.

3.110**maintenance area**

area where access can only be gained by the use of an **access key**

3.111**service area**

area where access cannot be gained by the use of an **access key** alone

3.112

appliance of the professional type

dispensing appliance that is only intended to be used by trained personnel such as kitchen or bar staff

3.113

appliance of the supervised type

dispensing appliance that is intended to be maintained by trained personnel but may be used by other persons in a location where its use is overseen

NOTE Dining rooms in restaurants are examples of such locations.

A1 3.114

potentially hazardous food

food which includes natural or synthetic ingredients that are capable of supporting rapid and progressive growth of pathogenic or toxin producing micro-organisms

NOTE 1 Examples of **potentially hazardous food** are milk, eggs, meat, poultry, shellfish, crustacean, and their products, either raw or heat treated, as well as food of plant origin that is ready for consumption without the need for any further preparation or processing.

NOTE 2 Food may become **potentially hazardous food** during processing, for example when powdered ingredients are mixed with water or when food is stored at incorrect temperature.

NOTE 3 **Potentially hazardous food** does not include:

- candy, nuts, gum and similar confectionery;
- cookies, crackers and similar bakery products;
- instant-coffee, chocolate, cocoa and sugar;
- food having a pH level of not greater than 4,6 or a water activity (A_w) value not greater than 0,85 at 25 °C;
- food maintained at a temperature not exceeding 5 °C for periods specified by the producer, but for not more than 5 days;
- food maintained at a temperatures above 65 °C or below -18 °C;
- food in hermetically sealed containers;
- food that has been processed to prevent spoilage. **A1**

4 General requirement

This clause of Part 1 is applicable.

5 General conditions for the tests

This clause of Part 1 is applicable except as follows.

5.2 Addition:

NOTE 101 If the test of 15.102 has to be carried out, three additional samples are required.

5.6 Replacement:

*Controls or switching devices in the **user area** are adjusted to the most unfavourable setting.*

*Controls, switching devices or other parts in the **maintenance area** are adjusted to the most unfavourable setting within limits stated in the **instructions for maintenance**.*

NOTE 101 Controls or switching devices in the **service area** are not adjusted.

5.9 Addition:

When alternative software is made available by the appliance manufacturer, the appliance is tested with the software that gives the most unfavourable results.

5.10 Addition:

NOTE 101 **Access keys** and **override keys** may be supplied separately from the appliance.

Appliances are installed in accordance with the instructions provided with the appliance before testing.

If the instructions state that the appliance may be installed together with other appliances, the effect of this combination is taken into account.

5.101 *Appliances intended to be connected to the water mains are supplied with water having a temperature of $15\text{ °C} \pm 5\text{ °C}$ and the most unfavourable pressure specified in the instructions. For appliances that are manually filled with water, the temperature of the water is $15\text{ °C} \pm 5\text{ °C}$.*

For appliances intended to cool water, the temperature of the water is $25\text{ °C} \pm 5\text{ °C}$.

5.102 *The requirements of this standard for the **maintenance area** are applicable when the **instructions for maintenance** are being followed. If an **override key** is provided for access to the **maintenance area**, it is used before a test is carried out if this is more unfavourable.*

5.103 *When reference is made to the application of test probe B, test probe 18 of IEC 61032 is also applied in the **user area**.*

5.104 *Appliances of the **professional type** and appliances of the **supervised type** are tested as **heating appliances** even if they incorporate a motor.*

NOTE If these appliances do not contain heating elements, they are tested as **motor-operated appliances**.

6 Classification

This clause of Part 1 is applicable except as follows.

6.1 Modification:

Appliances shall be **class I**, **class II** or **class III**.

6.2 Addition:

Appliances intended for outdoor use shall be at least IPX4.

Appliances that may be cleaned by water jets, or installed where water jets are liable to be used, shall be at least IPX5.

7 Marking and instructions

This clause of Part 1 is applicable except as follows.

7.1 Addition:

Appliance shall be marked with

- their **rated pressure**, in megapascals, if applicable;
- the maximum permissible water pressure, in megapascals, for appliances intended to be connected to the water mains.

Appliances intended to be filled by hand shall have means that indicate when the required level for correct operation has been reached.

NOTE 101 A level mark or an audible or visual signal are suitable means.

For appliances incorporating a socket outlet, the voltage, nature of the supply and current or power output shall be marked in the vicinity of the socket outlet.

Appliances intended to be partially immersed in water for cleaning shall be marked with the maximum level of immersion and with the substance of the following:

Do not immerse beyond this level.

7.3 Addition:

The requirement also applies when the adjustment has to be made by the **maintenance person**.

7.6 Addition:



[symbol 5021 of IEC 60417-1] equipotentiality

7.8 Addition:

Terminals for equipotential bonding shall be indicated by symbol 5021 of IEC 60417-1.

This symbol shall not be placed on screws, removable washers or other parts that can be removed when conductors are being connected.

7.12.1 Addition:

The installation instructions for appliances intended to be connected to the water mains shall specify the means of connection and draw attention to any national rules that may be applicable.

The installation instructions shall state if the appliance is suitable for outdoor use.

A1 The installation instructions shall state the maximum and minimum ambient temperatures for correct operation. **A1**

For appliances that are not at least IPX5, the instructions shall state that the appliance is not suitable for installation in an area where a water jet could be used.

The installation instructions shall state the maximum tilt of the appliance for safe operation.

NOTE 101 A tilt of less than 2° need not be stated. An instruction such as "the appliance has to be placed in a horizontal position" is sufficient.

The installation instructions for **appliances of the professional type** shall state that the appliance is only to be installed in locations where its use and maintenance is restricted to trained personnel.

The installation instructions for **appliances of the supervised type** shall state that the appliance is only to be installed in locations where it can be overseen by trained personnel.

The installation instructions for **class I appliances of the professional type** that are intended to be permanently connected to fixed wiring, and have a leakage current that may exceed 10 mA, shall state that the installation of a residual current device (RCD) having a rated residual operating current not exceeding 30 mA is advisable.

7.12.101 If it is necessary to take special precautions during **maintenance operations**, details of these shall be supplied. The **instructions for maintenance** shall state how to gain access to the **maintenance area** **A₁** including how to use the **access key** and the **override key**. **A₁** They shall not include instructions on how to gain access to a **service area**.

Compliance is checked by inspection.

7.12.101.1 **A₁** The **instructions for maintenance** shall specify the method and frequency of cleaning. They shall include details for descaling, disinfecting, flushing and removal of any residual cleaners, sterilizers or descalers from the appliance, if applicable. Recommended cleaning or disinfecting agents shall be specified.

NOTE 101 The agents may be identified by their chemical denomination. **A₁**

If the appliance is not at least IPX5, the **instructions for maintenance** shall state that the appliance must not be cleaned by a water jet.

The **instructions for maintenance** for appliances incorporating an appliance inlet, and intended to be partially or completely immersed in water for cleaning, shall state that the connector must be removed before the appliance is cleaned and that the appliance inlet must be dried before the appliance is used again.

Compliance is checked by inspection.

7.12.101.2 If the use of an **override key** allows access to moving parts, a suitable warning shall be given in the **instructions for maintenance**.

Compliance is checked by inspection.

7.12.101.3 The **instructions for maintenance** shall list any accessories that may be used with the appliance.

Compliance is checked by inspection.

7.12.101.4 The **instructions for maintenance** shall state the maximum and minimum ambient temperatures for correct operation.

For appliances using water, the **instructions for maintenance** shall give details concerning the prevention of freezing or how to ensure safe operation if freezing occurs.

Compliance is checked by inspection.

7.12.101.5 The **instructions for maintenance** for appliances containing pressurized gas shall give details on the safe handling of the pressurized containers and of the gas.

Compliance is checked by inspection.

A1 **7.12.101.6** The **instructions for maintenance** shall specify the types of food for which the appliance is suitable, and give details on how to ensure hygienic operation.

Compliance is checked by inspection.

7.12.101.7 The **instructions for maintenance** for appliances intended for dispensing **potentially hazardous food**, when the safety of the food depends upon the temperature and duration of storage, shall include details for the safe handling of the food.

Compliance is checked by inspection.

7.12.102 The instructions shall state that access to the **service area** is restricted to persons having knowledge and practical experience of the appliance, in particular as far as safety and hygiene are concerned.

Compliance is checked by inspection. **A1**

8 Protection against access to live parts

This clause of Part 1 is applicable.

9 Starting of motor-operated appliances

This clause of Part 1 is not applicable.

10 Power input and current

This clause of Part 1 is applicable.

11 Heating

This clause of Part 1 is applicable except as follows.

11.2 Modification:

Appliances normally fixed to the floor, and those having a mass greater than 40 kg and not provided with casters or rollers, are installed in accordance with the instructions.

NOTE 101 If no instructions are provided, the appliance is placed on the floor as close to the walls as possible.

*Other appliances, except **fixed appliances**, are placed on the floor as near to the walls as possible.*

11.4 Addition:

*If the temperature rise limits are exceeded in appliances incorporating motors, transformers or **electronic circuits**, and if the power input is lower than the **rated power input**, the test is repeated with the appliance supplied at 1,06 times the **rated voltage**.*

11.7 Replacement:

The appliance is operated under **normal operation** until steady conditions are established, the appliance being refilled when necessary.

NOTE 101 Refilling may require the use of an **access key**.

11.8 Addition:

The temperature rise of the surfaces in the **user area** shall not exceed the limits specified for handles, knobs, grips and similar parts that are held for short periods only.

NOTE 101 This does not apply to the surface of parts that need to be hot in order for the appliance to fulfil its function.

The temperature rise limits of motors, transformers and components of **electronic circuits**, including parts directly influenced by them, may be exceeded when the appliance is operated at 1,15 times the **rated power input**.

11.101 Appliances incorporating refrigerating equipment, and having motor-compressors that do not comply with IEC 60335-2-34, are also tested at an ambient temperature of

- 32° C, for appliances for temperate countries;
- 43° C, for appliances for tropical countries.

Other parts of the appliance are operated to produce the most unfavourable conditions in the refrigerating system.

Temperature rises of parts of the appliance, other than the motor-compressor, are not determined.

The temperature of windings and the enclosure of motor-compressors shall not exceed the following values:

- 140 °C, for windings of motor-compressors with synthetic insulation;
- 130 °C, for windings of motor-compressors with cellulosic insulation;
- 150 °C, for external enclosures of motor-compressors.

12 Void

13 Leakage current and electric strength at operating temperature

This clause of Part 1 is applicable except as follows.

13.2 Modification:

For **stationary class I heating appliances**, the leakage current shall not exceed the following values:

- | | |
|---|---|
| – for appliances of the professional type intended to be permanently connected to fixed wiring | 1 mA per kW rated power input of the appliance, with no maximum; |
| – for other appliances of the professional type | 1 mA per kW rated power input of the appliance, with a maximum of 10 mA; |
| – for other heating appliances | 0,75 mA or 0,75 mA per kW rated power input of the appliance, whichever is higher, with a maximum of 5 mA. |

14 Transient overvoltages

This clause of Part 1 is applicable.

15 Moisture resistance

This clause of Part 1 is applicable except as follows.

15.1.1 Addition:

Appliances of the professional type classified IPX3 or lower, and intended to be placed on a kitchen floor, are subjected to a test in which water under pressure is indirectly splashed onto the appliance. The splash apparatus is shown in Figure 101. The bowl is placed on the floor and the water pressure adjusted so that the water splashes to a height of 150 mm above the bottom of the bowl. The apparatus is moved around the appliance in order to splash it from all directions for a total of 5 min.

15.2 Replacement

Appliances subject to spillage of liquids or solids in normal use shall be constructed so that spillage does not affect their electrical insulation. The electrical insulation shall not be affected by cleaning, disinfecting, descaling and similar operations.

Compliance is checked by the tests of 15.2.101 to 15.2.113.

Water used for the tests shall contain approximately 1 % NaCl.

*Appliances with **type X attachment**, except those having a specially prepared cord, are fitted with the lightest permissible type of flexible cord of the smallest cross-sectional area specified in Table 11.*

Appliances incorporating an appliance inlet are tested with or without an appropriate connector in position, whichever is more unfavourable.

*Before each test, the appliance is operated in the **standby mode**. Containers that are connected to the water mains are prefilled with saline solution.*

*After each overfilling or application of liquid, the appliance shall withstand the electric strength test of 16.3 and inspection shall show that there is no trace of liquid or solids on insulation that could result in a reduction of **clearances** and **creepage distances** below the values specified in Clause 29. All residues are then removed and the appliance is dried.*

***Detachable parts** in the **user area** are removed or placed in the most unfavourable position.*

***Detachable parts** in the **maintenance area** are placed in their normal position following a **maintenance operation**.*

15.2.101 *Containers for ingredients or products in powdered or granulated form are filled with dry granulated sugar, ignoring any level indication. A further quantity equal to 15 % of the total capacity of the container is then poured in steadily over a period of 1 min.*

Containers that are intended to be filled outside the appliance are replaced without removing any excess sugar from the outside of the container. Lids are replaced after overfilling.

15.2.102 *Liquid containers that are filled manually are filled with saline solution and a further quantity equal to 15 % of the total capacity of each container or 0,25 l, whichever is the greater, is poured in steadily over a period of 1 min.*

15.2.103 *The outlets of liquid mixing containers are blocked and the containers are filled with saline solution. A further quantity equal to 15 % of the total capacity of each container or 0,25 l, whichever is the greater, is poured in steadily over a period of 15 s.*

NOTE If the container has more than one independent outlet, they are blocked in turn.

15.2.104 *Drains for liquid waste containers are blocked and the containers are filled with saline solution. A further quantity equal to 15 % of the total capacity of each container or 0,25 l, whichever is the greater, is poured in steadily over a period of 15 s.*

NOTE 1 If the container has more than one independent drain, they are blocked in turn.

NOTE 2 If there is more than one container, they are tested in turn.

15.2.105 *Drain taps of containers used during **maintenance operations** are adjusted in turn to the most unfavourable position. The appliance is supplied at **rated voltage** and operated under **normal operation** until the flow of saline solution stabilizes.*

15.2.106 *Failure of the inlet valve of appliances connected to the water mains is simulated. Water is allowed to flow for 1 min after the first evidence of overflow unless the inflow stops automatically.*

NOTE The failure of only one device is tested at a time.

15.2.107 *Appliances dispensing liquid into a serving container, such as a cup or jug, are tested by rapidly pouring 0,5 l of saline solution over the surface where the container is filled, transported and removed by the user.*

15.2.108 *Appliances with accessible openings, other than **appliances of the professional type** and **appliances of the supervised type**, are tested by slowly pouring 0,25 l of saline solution into each opening. If the opening is in a vertical surface, the solution is projected towards the opening.*

NOTE Accessible openings include slots for coins or cards.

15.2.109 *Appliances having external surfaces on which it is possible to place a vessel, such as a cup or jug, are tested by rapidly pouring 0,5 l of saline solution over the surface. The quantity of saline solution is increased to 5 l for **appliances of the professional type** if their highest surface is lower than 1,5 m.*

☞ *For espresso coffee machines **of the professional type** the amount of water is increased to 5 l only if the highest surface after installation is lower than 1,2 m. ☞*

NOTE 1 The test is carried out even if the appliance does not dispense liquid.

NOTE 2 If there is more than one surface, they are tested in turn.

15.2.110 *Appliances delivering prepacked products are tested to simulate leakage from the package over any area where the package is stored or transported.*

Leakage from liquid products is simulated by rapidly pouring a quantity of saline solution, equal in volume to the largest prepacked product that can be delivered from the appliance, over the area.

Leakage from dry products is simulated by rapidly pouring a quantity of dry granulated sugar, equal in volume to the largest prepacked product that can be delivered from the appliance, over the area.

NOTE This test is not applicable to appliances intended to deliver only solid products such as newspapers, films or cigarettes.

15.2.111 *Maintenance operations involving the use of liquids are carried out three times.*

15.2.112 *Parts liable to be cleaned are wiped with a sponge, having dimensions approximately 150 mm × 75 mm × 50 mm, saturated with saline solution. The sponge is applied without appreciable force for approximately 10 s to each surface.*

NOTE This test is not applied to surfaces in the **maintenance area** for which cleaning instructions are given.

15.2.113 *Appliances subject to descaling are descaled 10 times in accordance with the instructions for maintenance. The appliance is then operated in the **standby mode**.*

15.3 *Addition:*

NOTE 101 If it is not possible to place the appliance in the humidity cabinet, electrical parts are tested separately.

15.101 Appliances having a tap that provides water for filling or cleaning shall be constructed so that the water cannot come into contact with **live parts** or affect electrical insulation.

Compliance is checked by the following test.

The appliance is connected to the water mains, the pressure being adjusted to the maximum water pressure marked on the appliance. Tiltable and movable parts, including lids, are placed in the most unfavourable position. The tap is fully opened for 1 min, swivel outlets being adjusted to direct the water in the most unfavourable direction. The appliance shall then withstand the electric strength test of 16.3.

15.102 Appliances intended to be partially or completely immersed in water for cleaning shall have adequate protection against the effects of immersion.

Compliance is checked by the following tests, which are carried out on three additional appliances.

*The appliances are operated under **normal operation** at 1,15 times **rated power input**, until the **thermostat** operates for the first time. Appliances without a **thermostat** are operated until steady conditions are established. The appliances are disconnected from the supply, any appliance connector being withdrawn. They are then completely immersed in water containing approximately 1 % NaCl and having a temperature between 10 °C and 25 °C, unless they are marked with the maximum level of immersion, in which case they are immersed 50 mm deeper than this level.*

After 1 h, the appliances are removed from the saline solution, dried and subjected to the leakage current test of 16.2.

NOTE Care is taken to ensure that all moisture is removed from the insulation around the pins of appliance inlets.

This test is carried out four more times, after which the appliances shall withstand the electric strength test of 16.3, the voltage being as specified in Table 4.

*The appliance having the highest leakage current after the fifth immersion is dismantled and inspection shall show that there is no trace of liquid on insulation that could result in a reduction of **clearances** and **creepage distances** below the values specified in Clause 29.*

*The remaining two appliances are operated under **normal operation** at 1,15 times **rated power input** for 240 h. After this period, the appliances are disconnected from the supply and immersed again for 1 h. They are then dried and subjected to the electric strength test of 16.3, the voltage being as specified in Table 4.*

Inspection shall show that there is no trace of liquid on insulation that could result in a reduction of **clearances** and **creepage distances** below the values specified in Clause 29.

16 Leakage current and electric strength

This clause of Part 1 is applicable except as follows.

16.2 Modification:

For **stationary class I heating appliances**, the leakage current shall not exceed the following values:

- for **appliances of the professional type** intended to be permanently connected to fixed wiring 2 mA per kW **rated power input** of the appliance, with no maximum;
- for other **appliances of the professional type** 2 mA per kW **rated power input** of the appliance, with a maximum of 10 mA;
- for other heating appliances 0,75 mA or 0,75 mA per kW **rated power input** of the appliance, whichever is higher, with a maximum of 5 mA.

17 Overload protection of transformers and associated circuits

This clause of Part 1 is applicable.

18 Endurance

This clause of Part 1 is not applicable.

19 Abnormal operation

This clause of Part 1 is applicable except as follows.

19.1 Addition:

Appliances are also subjected to the tests of 19.101 and 19.102, if applicable.

Detachable parts in the **user area** are removed or placed in the most unfavourable position.

Detachable parts in the **maintenance area** are placed in their normal position following a **maintenance operation**.

Containers are filled to the most unfavourable level.

Appliances having a control that limits the pressure during the tests of Clause 11 are subjected to the tests of 19.4 with this control rendered inoperative.

19.2 Addition:

NOTE 101 Examples of achieving restricted heat dissipation are

- operating without water;
- switching off the fan;
- covering ventilation openings.

19.4 Addition:

NOTE 101 If a control also performs other functions, only the part controlling the temperature or pressure is rendered inoperative.

19.6 Addition:

NOTE 101 Care has to be taken to ensure that other parts of the appliance are not damaged by the voltage applied during this test. The voltage applied to the **PTC heating element** may be from a separate supply.

19.7 Addition:

The appliance is operated with the most unfavourable dispensing cycle for the motor under test.

19.11.2 Modification:

The fault conditions are simulated until steady conditions are established.

19.13 Addition:

During the tests, molten plastic shall not be emitted.

Liquid having a temperature above 80 °C, steam or solid objects shall not be emitted from unexpected places in a way likely to cause injury to persons.

After the tests, compliance with 15.1 and 15.2 shall not be impaired.

NOTE 101 The electric strength test may be carried out after each test if it is expected that the electrical insulation could be affected.

19.101 *The appliance is supplied at **rated voltage** and operated under **normal operation**. Any fault condition or unexpected operation likely to occur during use of the appliance is introduced.*

NOTE 1 Damaged components or parts may be replaced after each test.

NOTE 2 Examples of fault conditions or unexpected operation are

- defects in the appliance:
 - a programmer stopping in any position;
 - disconnection and reconnection of one or more phases of the supply mains during any part of the programme;
 - open-circuiting or short-circuiting of components;
 - locking the main contacts of a contactor in the “on” position if they are used for energizing heating elements. However, this defect is not introduced if at least two independent sets of contacts are provided. This may be achieved by two contactors operating independently of each other or by one contactor having two independent armatures operating two independent sets of main contacts;
 - failure of a magnetic valve;
 - failure of a pneumatic or hydraulic control;
 - blocking the coin or product channels. If blockage can be noticed from the outside of the appliance, further delivery is not attempted, otherwise the appliance is operated until no further delivery is possible. The wrapping of products in conductive materials has to be taken into account;
- faulty operation by users or **maintenance persons**:
 - incorrect actuation of knobs, handles, switches or push-buttons;
 - interrupting the dispensing operation by available facilities;
 - incorrect opening or closing of doors or lids;
 - improper application of the instructions for maintenance;

- incorrect routine cleaning. The sponge test of 15.2.112 is applied to all surfaces in the **user area**. It is also applied to all surfaces in the **maintenance area**, except those for which cleaning instructions are given;
 - setting controls, switches or programmers in the most unfavourable position;
 - incorrect loading;
 - incorrect coin collection;
- abuse by users:
- obstructing dispensing openings;
 - blocking moving parts.

NOTE 3 If operation without water in the appliance is considered to be a more unfavourable condition, the tests are carried out with the water supply valve closed. The water supply valve is not closed during the dispensing operation.

NOTE 4 In general, tests are limited to the fault conditions that may be expected to give the most unfavourable results.

19.102 *Appliances incorporating a **thermal cut-out** of the capillary type are tested as specified in 19.4 but with the capillary tube ruptured.*

20 Stability and mechanical hazards

This clause of Part 1 is applicable except as follows.

20.1 Modification:

*The appliance is tested with doors, lids and similar parts in the **maintenance area** placed in the normal position of use.*

The test with the appliance tilted to 15° is not carried out.

Addition:

*The test is repeated with doors, lids and similar parts in the **maintenance area** placed in the most unfavourable position, however, the appliance is only tilted to an angle of 5°.*

20.2 Addition:

Covers over moving parts having a kinetic energy exceeding 4 J shall be interlocked so that it is only possible to remove them when the parts are stationary unless they are only removable with the aid of a **tool**.

21 Mechanical strength

This clause of Part 1 is applicable except as follows.

A1 21.1 Addition:

*The impact energy of 0,5 J is applied in the **maintenance area**. In the **user area**, the value of the impact energy is 1,0 J. **A1***

22 Construction

This clause of Part 1 is applicable except as follows.

22.6 Addition:

NOTE 101 Parts that withstand the aging test of Annex AA are not considered to be parts where leakage could occur.

22.7 Addition:

Pressure relief devices shall be constructed so that they cannot be rendered inoperative or set to a higher pressure without the aid of a **tool** that is normally only available to the manufacturer.

Appliances incorporating pressurized systems are subjected to the following test.

All pressure regulating devices are rendered inoperative and the system is filled with water. The pressure is then raised hydraulically until the pressure relief device operates.

*The pressure shall not exceed 1,2 times the **rated pressure** and the appliance shall be fit for further use. The pressure relief device is then rendered inoperative and the pressure again raised until twice the **rated pressure** is attained. The pressure is maintained at this value for 5 min.*

*The system shall not rupture and there shall be no permanent deformation. However, an intentionally weak part may rupture after the pressure has attained 1,5 times the **rated pressure** as long as it does not give rise to a hazard. In this case, the weak part is replaced and the test repeated. Rupture shall occur in the same way.*

The appliance shall then withstand the electric strength test of 16.3.

NOTE 101 If fluid cannot circulate freely throughout the pressurized system, separate tests may be carried out on individual parts of the system.

NOTE 102 If more than one pressure relief device operates on the same part of the system, they are rendered inoperative together.

NOTE 103 This test is not made on refrigerating systems.

22.14 Addition:

The requirement also applies in the **maintenance area** to parts liable to be touched during **maintenance operations**.

22.33 Addition:

Ingredients and products shall not be in direct contact with **live parts** or, for **class II construction**, with **basic insulation**.

22.101 Appliances shall be constructed so that interlocks cannot be rendered inoperative without using an **override key** if they are necessary for compliance with the standard.

Compliance is checked by inspection, by manual test and by applying test probe B of IEC 61032.

22.102 It shall not be possible to gain access to the **service area** by only using the **access key** for the **maintenance area**.

Compliance is checked by inspection and by manual test.

22.103 Appliances shall be constructed so that scalding by steam is prevented when a lid is opened.

Compliance is checked by inspection and by the tests of Clause 19.

22.104 Appliances shall be constructed so that dispensed products cannot be contaminated by substances such as lubricants and debris.

Compliance is checked by inspection.

A1 Note deleted **A1**

22.105 Appliances shall be constructed so that it is not possible to inadvertently open draw-off taps and drain valves or withdraw drain plugs.

Compliance is checked by inspection and by manual test.

NOTE Valves that return automatically to the closed position when released, those of the wheel type or those placed in a recess are considered to comply with this requirement.

22.106 Coin boxes and containers for other payment means shall be positioned or protected so that overfilling cannot cause a hazard.

Compliance is checked by inspection.

22.107 Appliances intended to be connected to the water mains shall be constructed for a water pressure not less than 0,6 MPa.

Compliance is checked by inspection.

22.108 Appliances shall be protected in such a manner that moisture, grease and products used in the appliance will not accumulate so that **clearance** and **creepage distances** are affected.

Compliance is checked by inspection.

22.109 Lights indicating a warning against a hazard shall only be coloured red.

Compliance is checked by inspection.

22.110 Appliances having pressurized containers shall be constructed so that the lid cannot be removed while the pressure within the container is excessive. They shall incorporate a means to release the pressure to a value such that the lid can be removed without risk.

Compliance is checked by the following test.

The appliance is operated as specified in Clause 11 until the pressure regulator operates for the first time.

The appliance is then disconnected from the supply and the pressure allowed to decrease until the pressure is 4 kPa. A force of 100 N is applied to the most unfavourable point where the lid or its handle can be gripped. It shall not be possible to remove the lid.

The internal pressure is then gradually reduced, the force of 100 N being maintained. There shall be no hazardous displacement of the lid when it is released.

This test is not carried out on appliances when the lid is secured by screw clamps or other devices that ensure that the pressure is automatically reduced in a controlled manner before the lid can be removed.

A1 **22.111** Appliances for dispensing **potentially hazardous food** shall incorporate means to prevent the dispensing of the food if it has been adversely affected by storage or process temperatures.

Compliance is checked by inspection.

22.112 Surfaces of food areas and splash areas shall be cleanable so that all unwanted matter can be removed. If necessary, food areas shall be capable of being disinfected.

NOTE The food area comprises surfaces in contact with the food and surfaces that the food may contact during preparation of the product. The splash area comprises surfaces on which part of the food may splash or flow during normal use but this food does not become part of the product.

*Compliance is checked by inspection after having operated the appliance as in normal use and then cleaning and disinfecting it in accordance with the **instructions for maintenance**.*

22.113 Non-food areas that are not adequately separated from food areas of appliances that dispense food shall be constructed so that the retention of moisture or unwanted matter, and the ingress of vermin, is prevented. When this is unavoidable, the surfaces of the non-food areas shall be cleanable in accordance with 22.112.

NOTE 1 Non-food areas do not include splash areas.

NOTE 2 This requirement does not apply to appliances that dispense food in sealed containers such as cans and bottles.

Compliance is checked by inspection. **A1**

23 Internal wiring

This clause of Part 1 is applicable except as follows.

23.3 Modification:

The requirement also applies to **maintenance operations**.

The number of flexings is

- 200 000, for conductors flexed during normal use;
- 10 000, for conductors flexed during **maintenance operations**.

23.101 Anchorages for internal wiring that can easily be replaced shall be constructed and located so that

- the wiring cannot touch the clamping screws of the anchorage if these screws are accessible, unless they are separated from **accessible metal parts** by **supplementary insulation**;
- the wiring is not clamped by a metal screw that bears directly on the wiring;
- for **class I appliances**, the anchorages are of insulating material or are provided with an insulating lining, unless failure of the insulation of the wiring does not make **accessible metal parts** live;

- for **class II appliances**, the anchorages are of insulating material, or if of metal, they are insulated from **accessible metal parts** by **supplementary insulation**.

Compliance is checked by inspection.

23.102 Internal wiring that is accessible in the **maintenance area** and is moved during **normal operation** shall comply with 25.13, 25.14, 25.15 and 25.21.

Compliance is checked by the relevant tests.

24 Components

This clause of Part 1 is applicable except as follows.

24.1.5 Addition:

*For appliance couplers incorporating **thermostats**, **thermal cut-outs** or fuses in the connector, IEC 60320-1 is applicable except that*

- *the earthing contact of the connector is allowed to be accessible, provided that this contact is not likely to be gripped during insertion or withdrawal of the connector;*
- *the temperature required for the test of Clause 18 is that measured on the pins of the appliance inlet during the heating test of Clause 11 of this standard;*
- *the breaking-capacity test of Clause 19 is carried out using the inlet of the appliance;*
- *the temperature rise of current-carrying parts specified in Clause 21 is not determined.*

NOTE 101 Thermal controls are not allowed in connectors complying with the standard sheets of IEC 60320-1.

24.2 Modification:

Switches and automatic controls operating at **safety extra-low voltage** may be fitted in **interconnection cords** in the **maintenance area**.

C12 24.7 Modification:

Hose-sets do not need to be supplied with the appliance. C12

24.101 Connecting devices of **interconnection cords** shall be identified if they are interchangeable with other connecting means in the appliance, if this could result in a hazard.

NOTE Colour coding may be used for identification.

Compliance is checked by inspection.

24.102 Interlock switches shall comply with IEC 61058-1 as far as is reasonable and shall ensure **all-pole disconnection**. However, single-pole disconnection is allowed for protection against mechanical hazards.

Compliance is checked by testing the switch in accordance with the relevant clauses of IEC 61058-1, the number of cycles of operation for the test of Clause 17 being 10 000. However, if the switch is operated once per delivery, the number of cycles of operation is 100 000.

NOTE This requirement only applies to interlock switches necessary for compliance with this standard.

24.103 Thermal cut-outs incorporated for compliance with Clause 19 shall not be self-resetting. They shall have a trip-free mechanism if they disconnect heating elements and if they disconnect motors, the unexpected starting of which may cause a hazard to the user or **maintenance person**.

Compliance is checked by inspection and by manual test.

25 Supply connection and external flexible cords

This clause of Part 1 is applicable as follows.

25.7 Addition:

Supply cords of appliances intended for outdoor use shall be polychloroprene sheathed and not be lighter than ordinary polychloroprene sheathed cord (code designation 60245 IEC 57).

25.15 Addition:

When the test is carried out on internal wiring, the pull force is 30 N and the torque 0,1 Nm, irrespective of the mass of the appliance.

For internal wiring, a push force of 30 N is applied when pushing the wiring into the appliance.

26 Terminals for external conductors

This clause of Part 1 is applicable.

27 Provision for earthing

This clause of Part 1 is applicable except as follows.

27.2 Addition:

Stationary class I appliances of the professional type intended to be installed in kitchens shall incorporate a terminal for the connection of an external equipotential bonding conductor. This terminal shall be connected to all **accessible metal parts** of the appliance and shall allow the connection of a conductor having a nominal cross-sectional area of 2,5 mm² to 10 mm². It shall be located so that the conductor can be connected after installation of the appliance.

NOTE 101 This requirement does not apply to small parts such as nameplates.

28 Screws and connections

This clause of Part 1 is applicable except as follows.

28.1 Addition:

The requirement also applies to screws that may be removed during **maintenance operations**.

*The test also applies to screws likely to be tightened during **maintenance operations**.*

28.3 Addition:

The requirement also applies to screws operated by the **maintenance person**.

29 Clearances, creepage distances and solid insulation

This clause of Part 1 is applicable except as follows.

29.2 Addition:

The microenvironment is pollution degree 3 unless the insulation is enclosed or located so that it is unlikely to be exposed to pollution during normal use of the appliance due to

- condensation produced by the appliance;
- the use of liquids and solids, such as ingredients, products or cleaning agents.

30 Resistance to heat and fire

This clause of Part 1 is applicable except as follows.

30.2.2 Not applicable

31 Resistance to rusting

This clause of Part 1 is applicable.

32 Radiation, toxicity and similar hazards

This clause of Part 1 is applicable.

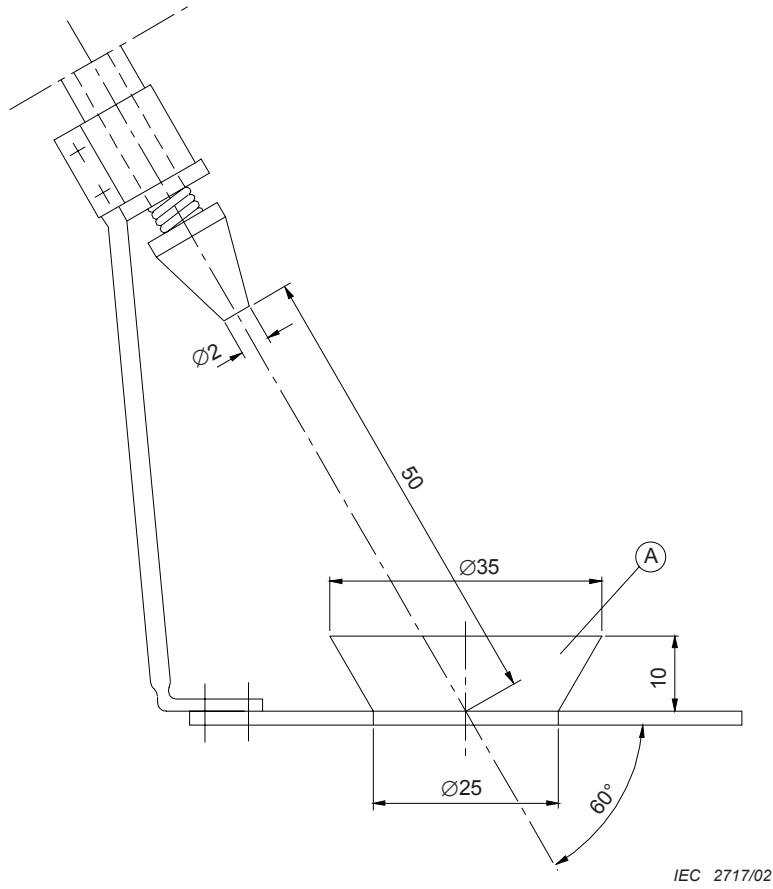

IEC 2717/02

Dimensions in millimetres

Key

A Bowl

Figure 101 – Splash apparatus

Annexes

The annexes of Part 1 are applicable except as follows.

Annex AA (normative)

Aging test for elastomeric parts

The aging test on elastomeric parts is carried out by measuring their hardness and mass before and after immersion in water at elevated temperature.

The test is carried out on at least three samples of each part. The samples and test procedure are as specified in ISO 1817 with the following modifications.

4 Test liquids

The test is carried out with water.

NOTE Care is to be taken to ensure that the total mass of the test pieces immersed does not exceed 100 g for each litre of water, that the test pieces are completely immersed and that their entire surface is freely exposed to the water. During the tests, the test pieces are not to be exposed to direct light. Test pieces of different compounds are not to be immersed at the same time in the same solution.

5 Test pieces

5.4 Conditioning of test pieces

The temperature is $23\text{ °C} \pm 2\text{ °C}$ and the relative humidity is $(50 \pm 5)\%$.

6 Immersion in the test liquid

6.1 Temperature

The water is heated within 1 h with the test pieces immersed, to a temperature of 75 °C^{+5}_0 and maintained at this value. Water at the same temperature is added to compensate for evaporation.

6.2 Duration

The test pieces are immersed for a total period of 48 h^{+1}_0 .

The test pieces are then immediately immersed in fresh water that is maintained at ambient temperature. The pieces are immersed for $45\text{ min} \pm 15\text{ min}$.

After removal from the water, the test pieces are dried with blotting paper.

7 Procedure

7.2 Change in mass

The increase in mass of the test pieces shall not exceed 10 % of the value determined before immersion.

7.6 Change in hardness

The micro-test for hardness applies.

The hardness of the test pieces shall not have changed by more than 8 IRHD. Their surface shall not have become sticky and shall show no crack visible to the naked eye or any other deterioration.

Bibliography

The bibliography of Part 1 is applicable except as follows.

Addition:

IEC 60335-2-24, *Household and similar electrical appliances – Safety – Part 2-24: Particular requirements for refrigerating appliances, ice cream appliances and ice-makers*

IEC 60335-2-25, *Household and similar electrical appliances – Safety – Part 2-25: Particular requirements for microwave ovens, including combination microwave ovens*

IEC 60335-2-47, *Household and similar electrical appliances – Safety – Part 2-47: Particular requirements for commercial electric boiling pans*

IEC 60335-2-50, *Household and similar electrical appliances – Safety – Part 2-50: Particular requirements for commercial electric bains-marie*

IEC 60335-2-64, *Household and similar electrical appliances – Safety – Part 2-64: Particular requirements for commercial electric kitchen machines*

IEC 60335-2-82, *Household and similar electrical appliances – Safety – Part 2-82: Particular requirements for amusement machines and personal service machines*

BSI - British Standards Institution

BSI is the independent national body responsible for preparing British Standards. It presents the UK view on standards in Europe and at the international level. It is incorporated by Royal Charter.

Revisions

British Standards are updated by amendment or revision. Users of British Standards should make sure that they possess the latest amendments or editions.

It is the constant aim of BSI to improve the quality of our products and services. We would be grateful if anyone finding an inaccuracy or ambiguity while using this British Standard would inform the Secretary of the technical committee responsible, the identity of which can be found on the inside front cover. Tel: +44 (0)20 8996 9000. Fax: +44 (0)20 8996 7400.

BSI offers members an individual updating service called PLUS which ensures that subscribers automatically receive the latest editions of standards.

Buying standards

Orders for all BSI, international and foreign standards publications should be addressed to Customer Services. Tel: +44 (0)20 8996 9001. Fax: +44 (0)20 8996 7001 Email: orders@bsigroup.com You may also buy directly using a debit/credit card from the BSI Shop on the Website <http://www.bsigroup.com/shop>

In response to orders for international standards, it is BSI policy to supply the BSI implementation of those that have been published as British Standards, unless otherwise requested.

Information on standards

BSI provides a wide range of information on national, European and international standards through its Library and its Technical Help to Exporters Service. Various BSI electronic information services are also available which give details on all its products and services. Contact Information Centre. Tel: +44 (0)20 8996 7111 Fax: +44 (0)20 8996 7048 Email: info@bsigroup.com

Subscribing members of BSI are kept up to date with standards developments and receive substantial discounts on the purchase price of standards. For details of these and other benefits contact Membership Administration. Tel: +44 (0)20 8996 7002 Fax: +44 (0)20 8996 7001 Email: membership@bsigroup.com

Information regarding online access to British Standards via British Standards Online can be found at <http://www.bsigroup.com/BSOL>

Further information about BSI is available on the BSI website at <http://www.bsigroup.com>

Copyright

Copyright subsists in all BSI publications. BSI also holds the copyright, in the UK, of the publications of the international standardization bodies. Except as permitted under the Copyright, Designs and Patents Act 1988 no extract may be reproduced, stored in a retrieval system or transmitted in any form or by any means – electronic, photocopying, recording or otherwise – without prior written permission from BSI.

This does not preclude the free use, in the course of implementing the standard, of necessary details such as symbols, and size, type or grade designations. If these details are to be used for any other purpose than implementation then the prior written permission of BSI must be obtained.

Details and advice can be obtained from the Copyright and Licensing Manager. Tel: +44 (0)20 8996 7070 Email: copyright@bsigroup.com