



BSI Standards Publication

Tests on electric and optical fibre cables under fire conditions —

Part 3-23: Test for vertical flame spread of vertically-mounted bunched wires or cables — Category B

NO COPYING WITHOUT BSI PERMISSION EXCEPT AS PERMITTED BY COPYRIGHT LAW

National foreword

This British Standard is the UK implementation of EN 60332-3-23:2009. It is identical to IEC 60332-3-23:2000, incorporating amendment 1:2008. It supersedes BS EN 50266-2-3:2001 which is withdrawn.

The start and finish of text introduced or altered by amendment is indicated in the text by tags. Tags indicating changes to IEC text carry the number of the IEC amendment. For example, text altered by IEC amendment 1 is indicated by $\boxed{A_1}$ $\boxed{A_1}$.

The UK participation in its preparation was entrusted by Technical Committee GEL/20, Electric cables, to Subcommittee GEL/20/18, Fire testing.

A list of organizations represented on this committee can be obtained on request to its secretary.

This publication does not purport to include all the necessary provisions of a contract. Users are responsible for its correct application.

© BSI 2010

ISBN 978 0 580 66770 1

ICS 29.060.20; 13.220.40; 29.020; 33.180.10

Compliance with a British Standard cannot confer immunity from legal obligations.

This British Standard was published under the authority of the Standards Policy and Strategy Committee on 31 January 2010

Amendments/corrigenda issued since publication

Amd. No.	Date	Text affected
----------	------	---------------

English version

**Tests on electric and optical fibre cables under fire conditions -
 Part 3-23: Test for vertical flame spread
 of vertically-mounted bunched wires or cables -
 Category B
 (IEC 60332-3-23:2000 + A1:2008)**

Essais des câbles électriques
 et des câbles à fibres optiques
 soumis au feu -
 Partie 3-23: Essai de propagation verticale
 de la flamme des fils ou câbles
 montés en nappes en position verticale -
 Catégorie B
 (CEI 60332-3-23:2000 + A1:2008)

Prüfungen an Kabeln, isolierten Leitungen
 und Glasfaserkabeln im Brandfall -
 Teil 3-23: Prüfung der vertikalen
 Flammenausbreitung von vertikal
 angeordneten Bündeln von Kabeln
 und isolierten Leitungen -
 Prüfkategorie B
 (IEC 60332-3-23:2000 + A1:2008)

This European Standard was approved by CENELEC on 2009-08-01. CENELEC members are bound to comply with the CEN/CENELEC Internal Regulations which stipulate the conditions for giving this European Standard the status of a national standard without any alteration.

Up-to-date lists and bibliographical references concerning such national standards may be obtained on application to the Central Secretariat or to any CENELEC member.

This European Standard exists in three official versions (English, French, German). A version in any other language made by translation under the responsibility of a CENELEC member into its own language and notified to the Central Secretariat has the same status as the official versions.

CENELEC members are the national electrotechnical committees of Austria, Belgium, Bulgaria, Cyprus, the Czech Republic, Denmark, Estonia, Finland, France, Germany, Greece, Hungary, Iceland, Ireland, Italy, Latvia, Lithuania, Luxembourg, Malta, the Netherlands, Norway, Poland, Portugal, Romania, Slovakia, Slovenia, Spain, Sweden, Switzerland and the United Kingdom.

CENELEC

European Committee for Electrotechnical Standardization
 Comité Européen de Normalisation Electrotechnique
 Europäisches Komitee für Elektrotechnische Normung

Central Secretariat: Avenue Marnix 17, B - 1000 Brussels

Foreword

The text of the International Standard IEC 60332-3-23:2000 and its amendment A1:2008, prepared by IEC TC 20, Electric cables, was submitted to the CENELEC Unique Acceptance Procedure and was accepted as EN 60332-3-23 on 2009-08-01.

This European Standard supersedes EN 50266-2-3:2001 + corrigendum March 2002.

The following dates were fixed:

- latest date by which the EN has to be implemented
at national level by publication of an identical
national standard or by endorsement (dop) 2010-08-01
- latest date by which the national standards conflicting
with the EN have to be withdrawn (dow) 2012-08-01

Annex ZA has been added by CENELEC.

Endorsement notice

The text of the International Standard IEC 60332-3-23:2000 and its amendment A1:2008 was approved by CENELEC as a European Standard without any modification.

Annex ZA (normative)

Normative references to international publications with their corresponding European publications

The following referenced documents are indispensable for the application of this document. For dated references, only the edition cited applies. For undated references, the latest edition of the referenced document (including any amendments) applies.

NOTE Where an International Publication has been modified by common modifications, indicated by (mod), the relevant EN/HD applies.

<u>Publication</u>	<u>Year</u>	<u>Title</u>	<u>EN/HD</u>	<u>Year</u>
IEC 60332-3-10	- ¹⁾	Tests on electric and optical fibre cables under fire conditions - Part 3-10: Test for vertical flame spread of vertically-mounted bunched wires or cables - Apparatus	EN 60332-3-10	2009 ²⁾
IEC 60695-4	- ¹⁾	Fire hazard testing - Part 4: Terminology concerning fire tests	EN 60695-4	2006 ²⁾
IEC 60811-1-3	- ¹⁾	Insulating and sheathing materials of electric and optical cables - Common test methods - Part 1-3: General application - Methods for determining the density - Water absorption tests - Shrinkage test	EN 60811-1-3	1995 ²⁾
IEC Guide 104	- ¹⁾	The preparation of safety publications and the use of basic safety publications and group safety publications	-	-

¹⁾ Undated reference.

²⁾ Valid edition at date of issue.

CONTENTS

INTRODUCTION.....	5
1 Scope.....	6
2 Normative references.....	6
3 Definitions	7
4 Test apparatus	7
4.1 General	7
4.2 Ignition source.....	7
5 Test procedure	7
5.1 Test sample.....	7
5.2 Determination of the number of test pieces	7
5.3 Mounting of the test sample	8
5.4 Flame application time.....	9
6 Evaluation of test results.....	9
7 Performance requirements.....	10
8 Retest procedure	10
9 Test report.....	10
 Annex A (normative) Guidance on cable selection for type approval testing.....	12
Annex B (informative) Recommended performance requirements	13
 Figure 1 – Spaced cables mounted on the front side of the standard ladder	11
Figure 2 – Touching cables mounted on the front side of the standard ladder (arrays of cables in contact)	11
 Table A.1 – Summary of test conditions.....	12

INTRODUCTION

Parts 1 and 2 of IEC 60332 specify methods of test for flame spread characteristics for a single vertical insulated wire or cable. It cannot be assumed that, because a cable or wire meets the requirements of parts 1 and 2, a vertical bunch of similar cables or wires will behave in a similar manner. This is because flame spread along a vertical bunch of cables depends on a number of features, such as

- a) the volume of combustible material exposed to the fire and to any flame which may be produced by the combustion of the cables;
- b) the geometrical configuration of the cables and their relationship to an enclosure;
- c) the temperature at which it is possible to ignite the gases emitted from the cables;
- d) the quantity of combustible gas released from the cables for a given temperature rise;
- e) the volume of air passing through the cable installation;
- f) the construction of the cable, for example armoured or unarmoured, multi- or single-core.

All of the foregoing assume that the cables are able to be ignited when involved in an external fire.

Part 3 of IEC 60332 gives details of a test where a number of cables are bunched together to form various test sample installations. For easier use and differentiation of the various test categories, the parts are designated as follows:

Part 3-10: Apparatus

Part 3-21: Category A F/R

Part 3-22: Category A

Part 3-23: Category B

Part 3-24: Category C

Part 3-25: Category D

Parts from 3-21 onwards define the various categories and the relevant procedures. The categories are distinguished by test duration, the volume of non-metallic material of the test sample and the method of mounting the sample for the test. In all categories, cables having at least one conductor of cross-sectional area greater than 35 mm² are tested in a spaced configuration, A_1 whereas cables of conductor cross-sectional area of 35 mm² or smaller and optical cables are tested in a touching configuration. A_1

The categories are not necessarily related to different safety levels in actual cable installations. The actual installed configuration of the cables may be a major determinant in the level of flame spread occurring in an actual fire.

The method of mounting described as category A F/R (part 3-21) is intended for special cable designs used in particular installations.

Categories A, B, C and D (parts 3-22 to 3-25 respectively) are for general use where different non-metallic volumes are applicable.

A_1 Text deleted A_1

Ⓐ₁ TESTS ON ELECTRIC AND OPTICAL FIBRE CABLES UNDER FIRE CONDITIONS –

Part 3-23: Test for vertical flame spread of vertically-mounted bunched wires or cables – Category B Ⓐ₁

1 Scope

The series of International standards covered by Parts 3-10, 3-21, 3-22, 3-23, 3-24 and 3-25 of IEC 60332 specifies methods of test for the assessment of vertical flame spread of vertically-mounted bunched wires or cables, electrical or optical, under defined conditions.

NOTE For the purpose of this standard, the term "electric wire or cable" covers all insulated metallic conductor cables used for the conveyance of energy or signals.

The test is intended for type approval testing. The requirements for the selection of cables for testing are given in annex A. The flame spread is measured as the extent of damage of the cable sample. This procedure may be used to demonstrate the cable's ability to limit flame spread.

This part of IEC 60332 covers category B and relates to cables installed on the test ladder to achieve a nominal total volume of non-metallic material of 3,5 l/m of test sample. The flame application time is 40 min. The method of mounting uses the front of the standard ladder. The category is intended for general use where medium volumes of non-metallic material are required to be evaluated.

A recommended performance requirement is given in annex B.

2 Normative references

The following referenced documents are indispensable for the application of this document. For dated references, only the edition cited applies. For undated references, the latest edition of the referenced document (including any amendments) applies.

IEC 60332-3-10: *Tests on electric cables under fire conditions – Part 3-10: Test for vertical flame spread of vertically-mounted bunched wires or cables – Apparatus*

IEC 60695-4: *Fire hazard testing – Part 4: Terminology concerning fire tests*

IEC 60811-1-3: *Insulating and sheathing materials of electric cables – Common test methods – Part 1: General application – Section 3: Methods for determining the density – Water absorption tests – Shrinkage test*

IEC Guide 104: *The preparation of safety publications and the use of basic safety publications and group safety publications*

3 Definitions

For the purpose of this part of IEC 60332 the following definitions apply. The definitions are taken from IEC 60695-4.

3.1

ignition source

source of energy that initiates combustion

3.2

char

carbonaceous residue resulting from pyrolysis or incomplete combustion

3.3

flame spread

propagation of a flame front

4 Test apparatus

4.1 General

The apparatus specified in IEC 60332-3-10 shall be used.

4.2 Ignition source

The ignition source shall be one ribbon-type propane gas burner as specified in IEC 60332-3-10.

5 Test procedure

5.1 Test sample

The test sample shall comprise a number of test pieces of cable from the same production length, each having a minimum length of 3,5 m.

The total number of test pieces in the test sample shall be that number required to provide a nominal total volume of non-metallic material of 3,5 l/m of test sample.

The test sample shall be chosen within the limitations given in annex A.

The test pieces forming the test sample shall be conditioned at a temperature of (20 ± 10) °C for at least 16 h before commencing the test. The test pieces shall be dry.

5.2 Determination of the number of test pieces

In order to calculate the appropriate number of test pieces, it is necessary to determine the volume per metre of non-metallic material of one test piece.

A length of cable which shall be not less than 0,3 m long is carefully cut to ensure that the surfaces are at right angles to the cable axis, thus enabling precise measurements of its length.

The density of each non-metallic component (including cellular material) shall be measured in an appropriate way, for example clause 8 of IEC 60811-1-3, in order to obtain values expressed to the second decimal place.

Each non-metallic material C_i shall be removed from the test piece and weighed. Any non-metallic material making up less than 5 % of the total non-metallic mass of the test piece shall be assumed to have a density of 1,0 kg/dm³.

Where semi-conducting screens cannot be removed from the insulating material, the components may be considered as one for the purpose of measuring their mass and density.

The volume V_i (litres per metre of cable) of each non-metallic material C_i is calculated as follows:

$$V_i = \frac{M_i}{\rho_i \times l}$$

where

M_i is the mass of the component C_i (kg);

ρ_i is the density of the component C_i (kg/dm³);

l is the length of the test piece of cable (m).

The total volume, V , of the non-metallic materials contained in 1 m of cable is equal to the sum of the individual volumes V_1 , V_2 , etc.

The closest integer (0,5 and above corresponding to 1) of the number of test pieces to be mounted is obtained by dividing the volume per metre specified in 5.1 by the total volume, V , of non-metallic material per metre of cable.

5.3 Mounting of the test sample

5.3.1 Cables having at least one conductor above 35 mm²

For cables having at least one conductor with a cross-section exceeding 35 mm², each test piece shall be attached individually to each rung of the ladder by means of metal wire (steel or copper). For cables up to and including 50 mm diameter, use wire between 0,5 mm and 1,0 mm diameter. For cables above 50 mm diameter, use wire between 1,0 mm and 1,5 mm in diameter.

Test pieces shall be attached to the front of the standard ladder in a single layer up to a total maximum width of 300 mm with a space between each test piece of 0,5 times the cable diameter but not exceeding 20 mm (see figure 1). There shall be a minimum distance of 50 mm between the edge of the test sample and the inside of the ladder uprights.

When mounting the test pieces, the first test piece shall be positioned approximately in the centre of the ladder and further test pieces added on either side so that the whole array of test pieces is approximately centred on the ladder.

5.3.2 **A1** Cables having conductors 35 mm² and below and optical cables

For cables having all conductors with cross-sections of 35 mm² or smaller, and optical cables, each test piece shall be attached, either individually or as part of an array, to each rung of the ladder by means of metal wire (steel or copper) between 0,5 mm and 1,0 mm in diameter. **A1**

Test pieces shall be attached to the front of the standard ladder in touching formation in one or more layers up to a maximum total width of 300 mm. There shall be a minimum distance of 50 mm between the edge of the test sample and the inside of the ladder uprights.

When mounting the test pieces, the first test piece or array of test pieces shall be positioned approximately in the centre of the ladder and further test pieces or arrays added on either side so that the test sample is approximately centred on the ladder.

If a second (or more) layer of test pieces is required after the full width of the ladder has been utilized for the first (or following) layer, then the first test piece or array of test pieces in the second (or following) layer shall be positioned approximately in the centre of the ladder and further test pieces or arrays added on either side so that the second (or following) layer is approximately centred on the ladder.

If a large number of test pieces are required to make up a test sample, the test pieces may be attached to each rung of the ladder in flat arrays of cables of a maximum width of five test pieces using the specified metal wire. For consistency, it is recommended that adjacent arrays of cables are secured together at every rung to ensure that they are in touching formation (see figure 2).

5.4 Flame application time

The test flame shall be applied for 40 min, after which it shall be extinguished. The air flow rate through the test chamber shall be maintained until cable burning or glowing has ceased, or until a maximum duration of 1 h, after which any remaining cable burning or glowing shall be extinguished.

6 Evaluation of test results

After all cable burning or glowing has ceased or been extinguished, the test sample shall be wiped clean.

All soot is to be ignored if, when wiped off, the original surface is undamaged. Softening or any deformation of the non-metallic material is also to be ignored. The flame spread shall be measured as the extent of the damage. It shall be measured in metres to two decimal places from the bottom edge of the burner to the onset of char. The onset of char is determined as follows:

press against the cable surface with a sharp object, for example a knife blade. Where the surface changes from a resilient to a brittle (crumbling) surface, this indicates the onset of char.

7 Performance requirements

The performance requirements for a particular type or class of wire or cable should preferably be given in the individual cable standard. In the absence of any given requirements, the recommended performance requirements given in annex B should be used.

8 Retest procedure

A1 In case of a disputed failure, two further tests **A1** shall be undertaken as detailed in clause 5. The test shall be deemed as satisfactory if both tests meet the stated requirement.

9 Test report

The test report shall include the following information:

- a) full description of the cable tested;
- b) manufacturer of the cable tested;
- c) the part of the standard against which the test was carried out;
- d) the number of test pieces;
- e) the total volume of non-metallic material, per metre of test sample, of the test pieces;
- f) the method of mounting, (i.e. spaced or touching);
- g) the number of layers and number of test pieces in each layer;
- h) flame application time (i.e. 40 min);
- i) the number of burners (i.e. one);
- j) the extent of damage;
- k) the time to extinction of all burning or glowing.

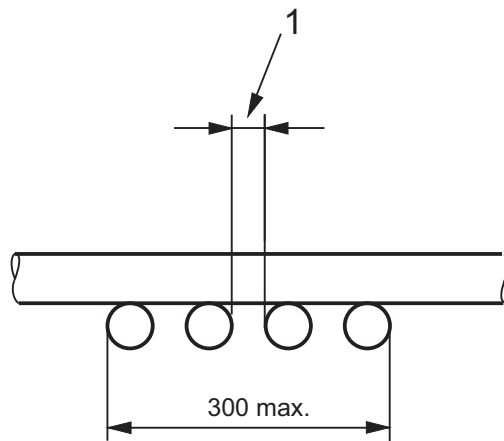

IEC 1860/2000

Key

- 1 Spacing distance

Dimensions in millimetres

Figure 1 – Spaced cables mounted on the front side of the standard ladder

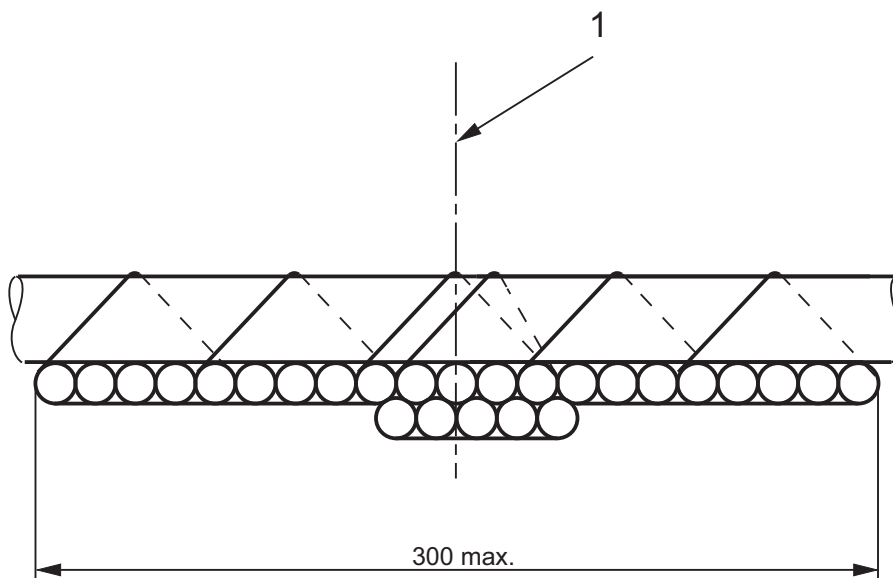

IEC 1862/2000

Key

- 1 Centre line of the ladder

Dimensions in millimetres

**Figure 2 – Touching cables mounted on the front side of the standard ladder
(arrays of cables in contact)**

Annex A
(normative)

Guidance on cable selection for type approval testing

The choice of cable type and conductor cross-section for type approval testing shall be as given in the cable specification, or as agreed between purchaser and manufacturer.

The limited capacity of the ladders requires consideration of the conductor cross-section selected for testing to ensure that the volume of non-metallic material can be accommodated within the prescribed method of mounting. Therefore the selection of cables for this part of IEC 60332 shall comply with the following:

- only the front face of the ladder shall be used;
- for cables having a conductor cross-section greater than 35 mm², there shall not be more cables than the number necessary to form a single layer of 300 mm width, allowing for a space between each cable equal to half the cable diameter but not exceeding 20 mm;
- $\square A_1$ for cables having a conductor cross-section of 35 mm² or smaller and optical cables, there is no restriction on cable selection; $\square A_1$
- the minimum number of test pieces shall be two.

A summary of all conditions for type approval testing to this part of IEC 60332 is given in table A.1.

Table A.1 – Summary of test conditions

Category and designation	B	
	>35 ^a	≤35 ^b
Range of conductor cross-sections (mm ²)	>35 ^a	≤35 ^b
Non-metallic volume per metre of test sample (l)	3,5	3,5
Use of standard ladder, maximum width of test sample: 300 mm		
– number of layers:	1	≥1
– number of burners:	1	1
Positioning of test pieces	Spaced	Touching
Flame application time (min)	40	40
^a At least one conductor greater than 35 mm ² . $\square A_1$ ^b No conductor cross-section exceeding 35 mm ² or optical cable. $\square A_1$		

Annex B
(informative)

Recommended performance requirements

The maximum extent of the charred portion measured on the sample shall not have reached a height exceeding 2,5 m above the bottom edge of the burner.

This recommended performance requirement confirms, on the basis of experience gained, the value previously given in 2.8.1 of technical report IEC 60332-3, *Tests on electric cables under fire conditions – Part 3: Tests on bunched wires or cables*, published in 1992.

British Standards Institution (BSI)

BSI is the independent national body responsible for preparing British Standards and other standards-related publications, information and services.

It presents the UK view on standards in Europe and at the international level.

It is incorporated by Royal Charter.

Revisions

British Standards are updated by amendment or revision. Users of British Standards should make sure that they possess the latest amendments or editions.

It is the constant aim of BSI to improve the quality of our products and services. We would be grateful if anyone finding an inaccuracy or ambiguity while using this British Standard would inform the Secretary of the technical committee responsible, the identity of which can be found on the inside front cover.

Tel: +44 (0)20 8996 9001 Fax: +44 (0)20 8996 7001

BSI offers Members an individual updating service called PLUS which ensures that subscribers automatically receive the latest editions of standards.

Tel: +44 (0)20 8996 7669 Fax: +44 (0)20 8996 7001

Email: plus@bsigroup.com

Buying standards

You may buy PDF and hard copy versions of standards directly using a credit card from the BSI Shop on the website www.bsigroup.com/shop. In addition all orders for BSI, international and foreign standards publications can be addressed to BSI Customer Services.

Tel: +44 (0)20 8996 9001 Fax: +44 (0)20 8996 7001

Email: orders@bsigroup.com

In response to orders for international standards, it is BSI policy to supply the BSI implementation of those that have been published as British Standards, unless otherwise requested.

Information on standards

BSI provides a wide range of information on national, European and international standards through its Knowledge Centre.

Tel: +44 (0)20 8996 7004 Fax: +44 (0)20 8996 7005

Email: knowledgecentre@bsigroup.com

Various BSI electronic information services are also available which give details on all its products and services.

Tel: +44 (0)20 8996 7111 Fax: +44 (0)20 8996 7048

Email: info@bsigroup.com

BSI Subscribing Members are kept up to date with standards developments and receive substantial discounts on the purchase price of standards. For details of these and other benefits contact Membership Administration.

Tel: +44 (0)20 8996 7002 Fax: +44 (0)20 8996 7001

Email: membership@bsigroup.com

Information regarding online access to British Standards via British Standards Online can be found at www.bsigroup.com/BSOL

Further information about BSI is available on the BSI website at www.bsigroup.com/standards

Copyright

Copyright subsists in all BSI publications. BSI also holds the copyright, in the UK, of the publications of the international standardization bodies. Except as permitted under the Copyright, Designs and Patents Act 1988 no extract may be reproduced, stored in a retrieval system or transmitted in any form or by any means – electronic, photocopying, recording or otherwise – without prior written permission from BSI. This does not preclude the free use, in the course of implementing the standard of necessary details such as symbols, and size, type or grade designations. If these details are to be used for any other purpose than implementation then the prior written permission of BSI must be obtained. Details and advice can be obtained from the Copyright & Licensing Manager.

Tel: +44 (0)20 8996 7070

Email: copyright@bsigroup.com

BSI Group Headquarters

389 Chiswick High Road London W4 4AL UK

Tel +44 (0)20 8996 9001

Fax +44 (0)20 8996 7001

www.bsigroup.com/standards