

Appliance coupler for household and similar general purposes —

Part 2-3: Appliance coupler with a degree of protection higher than IPX0

The European Standard EN 60320-2-3:1998, with the incorporation of amendment A1:2005, has the status of a British Standard

ICS 29.120.30

National foreword

This British Standard is the English language version of EN 60320-2-3:1998, including amendment A1:2005. It is identical with IEC 60320-2-3:1998, including amendment 1:2004.

The start and finish of text introduced or altered by IEC amendment is indicated in the text by tags $\boxed{A1}$ $\langle A1 \rangle$. Tags indicating changes to IEC text carry the number of the IEC amendment. For example, text altered by IEC amendment 1 is indicated in the text by $\boxed{A1}$ $\langle A1 \rangle$.

The UK participation in its preparation was entrusted by Technical Committee PEL/23, Electrical accessories, to Subcommittee PEL/23/3, Appliance couplers, which has the responsibility to:

- aid enquirers to understand the text;
- present to the responsible international/European committee any enquiries on the interpretation, or proposals for change, and keep the UK interests informed;
- monitor related international and European developments and promulgate them in the UK.

A list of organizations represented on this subcommittee can be obtained on request to its secretary.

Cross-references

The British Standards which implement international or European publications referred to in this document may be found in the *BSI Catalogue* under the section entitled “International Standards Correspondence Index”, or by using the “Search” facility of the *BSI Electronic Catalogue* or of British Standards Online.

This publication does not purport to include all the necessary provisions of a contract. Users are responsible for its correct application.

Compliance with a British Standard does not of itself confer immunity from legal obligations.

Summary of pages

This document comprises a front cover, an inside front cover, pages i and ii, the EN title page, pages 2 to 21 and a back cover.

This standard has been updated (see copyright date) and may have had amendments incorporated. This will be indicated in the amendment table on the inside front cover.

Amendments issued since publication

Amd. No.	Date	Comments
15808	31 May 2006	See National foreword

This British Standard, having been prepared under the direction of the Electrotechnical Sector Committee, was published under the authority of the Standards Committee and comes into effect on 15 January 1999

© BSI 2006

ISBN 0 580 30895 2

Contents

	Page
National foreword	Inside front cover
Foreword	2
Text of EN 60320-2-3	4

ICS 29.120.30

Descriptors: Appliance couplers, household appliances, connectors, reinforced protection, requirements, dimension, construction, test

English version

Appliance coupler for household and similar general purposes Part 2-3: Appliance coupler with a degree of protection higher than IPX0

(includes amendment A1:2005)
(IEC 60320-2-3:1998 + A1:2004)

Connecteurs pour usages domestiques
et usages généraux analogues
Partie 2-3: Connecteurs avec degré de
protection supérieur à IPX0
(inclut l'amendement A1:2005)
(CEI 60320-2-3:1998 + A1:2004)

Gerätesteckvorrichtungen für den
Hausgebrauch und ähnliche allgemeine Zwecke
Teil 2-3: Gerätesteckvorrichtungen mit einem
Schutzgrad höher als IPX0
(enthält Änderung A1:2005)
(IEC 60320-2-3:1998 + A1:2004)

This European Standard was approved by CENELEC on 1998-10-01; amendment A1:2005 was approved by CENELEC on 2005-02-01. CENELEC members are bound to comply with the CEN/CENELEC Internal Regulations which stipulate the conditions for giving this European Standard the status of a national standard without any alteration.

Up-to-date lists and bibliographical references concerning such national standards may be obtained on application to the Central Secretariat or to any CENELEC member.

This European Standard exists in three official versions (English, French, German). A version in any other language made by translation under the responsibility of a CENELEC member into its own language and notified to the Central Secretariat has the same status as the official versions.

CENELEC members are the national electrotechnical committees of Austria, Belgium, Cyprus, Czech Republic, Denmark, Estonia, Finland, France, Germany, Greece, Hungary, Iceland, Ireland, Italy, Latvia, Lithuania, Luxembourg, Malta, Netherlands, Norway, Poland, Portugal, Slovakia, Slovenia, Spain, Sweden, Switzerland and United Kingdom.

CENELEC

European Committee for Electrotechnical Standardization
Comité Européen de Normalisation Electrotechnique
Europäisches Komitee für Elektrotechnische Normung

Central Secretariat: rue de Stassart 35, B-1050 Brussels

Foreword

The text of document 23G/185/FDIS, future edition 1 of IEC 60320-2-3, prepared by SC 23G, Appliance couplers, of IEC TC 23, Electrical accessories, was submitted to the IEC-CENELEC parallel vote and was approved by CENELEC as EN 60320-2-3 on 1998-10-01.

The following dates were fixed:

- latest date by which the EN has to be implemented at national level by publication of an identical national standard or by endorsement (dop) 1999-07-01
- latest date by which the national standards conflicting with the EN have to be withdrawn (dow) 2001-07-01

This part 2 is to be used in conjunction with EN 60320-1. It was established on the basis of the 1996 edition of that part 1 and its amendments 1 (1996) and 2 (1998).

This part 2 supplements or modifies the corresponding clauses of EN 60320-1.

Where a particular subclause of part 1 is not mentioned in this part 2, that subclause applies as far as is reasonable. Where this part 2 states “addition”, “amendment” or “replacement”, the relevant text of part 1 is to be adapted accordingly.

Subclauses which are additional to those in part 1 are numbered starting from 101.

Annexes designated “normative” are part of the body of the standard.

Annexes designated “informative” are given for information only.

In this standard, Annex ZA is normative and Annex A is informative.

Annex ZA has been added by CENELEC.

Endorsement notice

The text of the International Standard IEC 60320-2-3:1998 was approved by CENELEC as a European Standard without any modification.

Foreword to amendment A1

The text of document 23G/243/FDIS, future amendment 1 to IEC 60320-2-3:1998, prepared by SC 23G, Appliance couplers, of IEC TC 23, Electrical accessories, was submitted to the IEC-CENELEC parallel vote and was approved by CENELEC as amendment A1 to EN 60320-2-3 on 2005-02-01.

The following dates were fixed:

- latest date by which the amendment has to be implemented at national level by publication of an identical national standard or by endorsement (dop) 2005-11-01
- latest date by which the national standards conflicting with the amendment have to be withdrawn (dow) 2008-02-01

Endorsement notice

The text of amendment 1:2004 to the International Standard IEC 60320-2-3:1998 was approved by CENELEC as an amendment to the European Standard without any modification.

Contents

	Page		Page
Foreword	2	22 Cords and their connection	11
1 Scope	4	23 Mechanical strength	12
2 Normative references	4	24 Resistance to heat and ageing	13
3 Definitions	4	25 Screws, current-carrying parts and connections	13
4 General requirements	4	26 Creepage distances, clearances and distances through insulation	13
5 General notes on tests	4	27 Resistance of insulating material to heat, fire and tracking	13
6 Standard ratings	5	28 Resistance to rusting	13
7 Classification	5	29 Electromagnetic compatibility (EMC) requirements	13
8 Marking	5	Annex A (informative) Routine tests for factory wired appliance couplers related to safety (protection against electric shock and correct polarity)	14
9 Dimensions and compatibility	6	Annex ZA (normative) Normative references to international publications with their corresponding European publications	21
10 Protection against electric shock	7	Standard sheets	
11 Provision for earthing	7	Figure 1 — “GO” gauge for connectors according to standard sheet A (see 9.1)	17
12 Terminals and terminations	7	Figure 2 — Primary and supplementary “GO” gauge for appliance inlets according to standard sheet B (see 9.1)	18
13 Construction	7	Figure 3 — Example of apparatus for inadvertent disengagement (see 16.101)	19
14 Moisture resistance	8	Figure 4 — Withdrawal pull gauge (see 13.5)	20
15 Insulation resistance and electric strength	9		
16 Forces necessary to insert and to withdraw the connector	9		
17 Operation of contacts	10		
18 Resistance to heating of appliance couplers for hot conditions or very hot conditions	10		
19 Breaking capacity	10		
20 Normal operation	10		
21 Temperature rise	10		

1 Scope

This clause of IEC 60320-1 applies amended as follows:

This standard applies to two-pole non-reversible appliance couplers for cold conditions for a.c. only, with a degree of protection against ingress of water higher than IPX0, with a rated voltage not exceeding 250 V and a rated current not exceeding 10 A for a 50 Hz or 60 Hz supply.

Ⓐ) They are intended for the connection of the circular supply cord to electrical appliances of class II for household, commercial and light industrial use. Ⓐ1

NOTE 1 This note of IEC 60320-1 applies.

NOTE 2 This note of IEC 60320-1 applies.

NOTE 3 This note of IEC 60320-1 applies.

NOTE 4 This note of IEC 60320-1 does not apply.

NOTE 5 This note of IEC 60320-1 applies.

Additional notes:

NOTE 6 IEC 60529 specifies the degree of protection against the ingress of water (IP code).

NOTE 7 IEC 60536 specifies the class of equipment.

2 Normative references

This clause of IEC 60320-1 applies with the following additions:

IEC 60320-1:1994, *Appliance couplers for household and similar general purposes — Part 1: General requirements*.

IEC 60529:1989, *Degrees of protection provided by enclosures (IP code)*.

3 Definitions

This clause of IEC 60320-1 applies with the following additions:

3.101 plug connector

appliance inlet intended to be attached by a cord to equipment

3.102 accessible surface of an accessory

surface of an accessory that can be touched by means of the test finger shown in Figure 10 of IEC 60320-1, when the accessory is assembled as in normal use and in the following conditions:

- a) for connectors: without the complementary accessory in engagement but with the cover in the open position;
- b) for plug connectors and appliance inlets: with the complementary accessory in the most unfavourable degree of engagement but such that electrical contact is made between the contacts (pins and tubes).

3.103 cover

part that is accessible when the accessory is in normal use and removable only with the use of a tool, but which does not require the use of a tool to open it

3.104 type test sample

sample consisting of one or more similar specimens submitted for the purpose of a type test

4 General requirements

This clause of IEC 60320-1 applies.

5 General notes on tests

This clause of IEC 60320-1 applies amended as follows:

5.1 This subclause of IEC 60320-1 applies.

5.2 Replacement:

Unless otherwise specified, the specimens are tested as delivered and under normal conditions of use, at an ambient temperature of $20\text{ °C} \pm 5\text{ °C}$; they are tested with a.c. at 50 Hz or 60 Hz.

The specimens used for the tests shall be substantially identical to normal production items in respect of all details which may affect the test results.

Non-rewirable accessories shall be submitted with a cord at least 1 m long. The cord used for testing rewirable accessories shall be a sheathed circular flexible cord complying with 60227 IEC 53 unless otherwise specified in a particular clause.

5.3 This subclause of IEC 60320-1 does not apply.

5.4 This subclause of IEC 60320-1 does not apply.

5.5 Replacement:

A total sample comprising 18 specimens, of any one type, shall be submitted to inspection and tests as given in the following table:

Test	Number of specimens	Order of tests (clause and subclause references)
1 Visual inspection and manual examination	3	7, 8, 9, 10, 12, 13, 24.1, 25, 26, 28
2 General tests	3	14 (except 14.101), 15
3 General tests	3	22 (except 22.4), 16, 17, 19, 20, 21
4 Flexing test	3	22.4
5 Material test	3	23, 24.2, 14.101, 15.3
6 Material test	3	24.2, 27

NOTE 1 If any particular test is repeated, as part of the normal sequence, this requirement is specified in the appropriate clause.

NOTE 2 With the agreement of the manufacturer the same specimen may be used for more than one test sequence.

5.6 This subclause of IEC 60320-1 applies.

5.7 Replacement:

If no accessory fails in the complete series of tests specified in 5.5, then the accessories of that type are considered to comply with this standard.

If one accessory in any group fails in the complete series of tests specified in 5.5, then the accessories of that type are considered to have failed to comply with this standard, unless that accessory can be shown not to be of normal production or design, in which case a further set of accessories shall be submitted to the test or tests in that group. If there is no failure in this retest then the accessories of that type shall be deemed to comply with this standard.

If more than one accessory fails in the complete series of tests specified in 5.5, the accessories of that type shall be deemed to have failed to comply with this standard.

6 Standard ratings

This clause of IEC 60320-1 applies amended as follows:

6.1 This subclause of IEC 60320-1 applies.

6.2 Replacement:

A₁ The rated current is 6 A or 10 A. **A₁**

7 Classification

This clause of IEC 60320-1 applies amended as follows:

7.1.1 Amendment:

Only the reference to cold conditions applies.

7.1.2 Amendment:

Only the reference to class II equipment applies.

7.2 Replacement:

Accessories are classified, according to the method of connecting the cord, as:

- rewirable accessories;
- non-rewirable accessories.

Additional subclause:

7.101 Add a new classification:

Accessories are classified, according to the ambient temperature for their use, as:

- appliance couplers for use in normal temperature;
- appliance couplers for use in low temperature (– 15 °C).

NOTE Additional tests are under consideration for appliance couplers for use in low temperature.

8 Marking

This clause of IEC 60320-1 applies amended as follows:

8.1 Replacement:

Couplers, except for appliance inlets supplied with the equipment, shall be marked with:

- a) name, trade mark or identification mark of the maker or responsible vendor;
- b) number of this standard;
- c) rated current;
- d) rated voltage;
- e) symbol for nature of supply;
- f) IP rating;
- g) type reference, which may be a catalogue number, code number, etc.

8.2 Replacement:

Appliance inlets shall be marked with the information given in 8.1 a) and 8.1 g) which need not be visible when installed for use outdoors.

NOTE The marking on connectors and appliance inlets need not be visible when these are connected together.

8.3 This subclause of IEC 60320-1 applies.

8.4 This subclause of IEC 60320-1 applies with the following additional symbols:

Line	L
Neutral	N
Protected against splashing water	IPX4

NOTE In the IP code the letter X, concerning protection against ingress of solid objects, is replaced by the relevant number.

8.5 This subclause of IEC 60320-1 does not apply.

8.6 *Amendment:*

This subclause of IEC 60320-1 applies except for the reference to earthing contact and earthing terminal.

8.7 This subclause of IEC 60320-1 applies.

8.8 This subclause of IEC 60320-1 applies.

Additional subclauses:

8.101 Cords of non-rewirable accessories shall not be coloured black, green, white or brown.

8.102 For couplers intended for retail sale the supplier shall include an instruction leaflet, on or inside the sales package, with each coupler or accessory, clearly describing the extent of its suitability for use outdoors. Information regarding weather resistance shall be clearly visible to the purchaser and a recommendation shall be made that the cord to be fitted to the accessory should not be coloured black, green, white or brown. The instruction sheet shall include information stating that the plug connector shall be connected to the equipment and the connector to the mains supply side.

If the coupler or accessory is non-rewirable with a cord attached, each free end shall be marked for connection to the appliance or mains supply as appropriate, with guidance on the danger of an incorrect connection or of a connection to an appliance requiring the protection of an earth continuity conductor.

Except when a plug connector or appliance inlet fitted with a cord is supplied direct to a manufacturer for incorporation in other equipment, the free end of such an assembly shall have a label attached stating:

“The cord of this accessory must be properly connected to a piece of equipment before the appliance is energised.”

If the coupler or accessory is rewirable, instructions shall be provided on the following:

- stripping lengths for sheath and insulation;
- identity of accessories to be connected to appliance or mains cord, as appropriate;
- connection of brown wire to terminal marked L and blue wire to terminal marked N;

- importance of correct assembly of cord anchorage including need for at least 3 mm of sheath to protrude beyond the clamping device;
- suitable for use with circular type cords only.

Compliance with the requirements of 8.101 and 8.102 is checked by inspection.

9 Dimensions and compatibility

This clause of IEC 60320-1 applies amended as follows:

9.1 *Replacement:*

Ⓐ Couplers shall comply with the dimensions shown in the appropriate standard sheets given in the table below, except as permitted by 9.6.

Rating	Connector Standard sheet	Inlet Standard sheet
6 A	C	D
10 A	A	B

Compliance is checked by measurement and where relevant by use of the appropriate gauge.

When the appropriate gauge of Figure 1 or Figure 1A is used, it shall be possible to insert the connector fully with a force not exceeding 60 N. To verify correct and full insertion the gauge insert shall be provided with an aperture.

When the appropriate primary and supplementary gauges of Figures 2 and 2A are used it shall be possible to insert the primary gauge fully into the appliance inlet with a force not exceeding 60 N. The supplementary gauges shall be pushed over the bar. Planes shall be provided with the primary gauge to check pin and shroud lengths; successful engagement of the supplementary gauge checks the appliance inlet outer recess. Ⓐ

9.2 *Replacement:*

Provision for retaining the connector in the plug connector or appliance inlet shall comply with standard sheets A and B.

Compliance is checked by the tests of clause 16.

9.3 This subclause of IEC 60320-1 applies.

Ⓐ 9.4 *Replacement:*

It shall not be possible to engage:

- connectors for class II equipment with appliance inlets for other equipment;
- 6 A connectors into 10 A inlets.

Compliance is checked by inspection, by manual test and by means of the appropriate gauge.

The test is carried out at an ambient temperature of $35\text{ °C} \pm 2\text{ °C}$, both the accessories and the gauges being at this temperature. Ⓐ

9.5 This subclause of IEC 60320-1 applies.

9.6 This subclause of IEC 60320-1 applies.

10 Protection against electric shock

This clause of IEC 60320-1 applies amended as follows:

10.1 Replacement:

Appliance couplers shall be so designed that live parts of appliance inlets are not accessible when the connector is in partial or complete engagement.

Connectors shall be so designed that live parts are not accessible when the connector is properly assembled and wired as in normal use, but with the cover open.

Compliance is checked by inspection and, if necessary, by a test with the test finger shown in Figure 10 of IEC 60320-1. This finger is applied in every possible position, an electrical indicator being used to show contact with the relevant parts. For connectors with shrouds, enclosures or bodies of elastomeric or thermoplastic material, the test finger is applied for $30\text{ s} \pm 5\text{ s}$ with a force of $20\text{ N} \pm 3\text{ N}$ at all points where yielding of the insulating material could impair the safety of the connector; this test is made at an ambient temperature of $35\text{ °C} \pm 2\text{ °C}$.

NOTE 1 An electrical indicator with a voltage between 40 V and 50 V is used to show contact with the relevant part.

NOTE 2 Conformity to the standard sheets ensures compliance with the requirements so far as the inaccessibility of contact members during insertion of a connector into an appliance inlet is concerned.

10.2 This subclause of IEC 60320-1 applies.

10.3 This subclause of IEC 60320-1 applies.

10.4 This subclause of IEC 60320-1 applies.

11 Provision for earthing

This clause of IEC 60320-1 does not apply.

12 Terminals and terminations

This clause of IEC 60320-1 applies amended as follows:

12.1 General

The requirements of this subclause apply only to connectors and plug connectors.

For appliance inlets submitted as individual accessories not integrated or incorporated in an electrical appliance or equipment, particular requirements may be needed.

For appliance inlets integrated or incorporated in an electrical appliance or equipment, the requirements in the appropriate IEC standard for that equipment shall apply.

12.1.1 Replacement of first paragraph:

Rewirable accessories shall be provided with terminals with screw clamping.

Replacement of third paragraph:

Non-rewirable accessories shall be provided with soldered, welded, crimped or equally effective screwless connections, which shall not allow disconnection of the conductor: screwed connections shall not be used.

12.1.2 This subclause of IEC 60320-1 applies.

12.1.3 Replacement:

A₁ Rewirable connectors shall have terminals of size 1, which can accept conductors having a nominal cross-sectional area of $0,75\text{ mm}^2$ and 1 mm^2 .

NOTE The terminal size number relates to the terminal dimensions in IEC 60320-1 standard sheets C26 and C27.

Compliance is checked by inspection, by measurement and by fitting conductors having cross-sectional areas of $0,75\text{ mm}^2$ and 1 mm^2 . **A₁**

12.2 Screw-type terminals

12.2.1 This subclause of IEC 60320-1 applies.

12.2.2 This subclause of IEC 60320-1 applies.

12.2.3 This subclause of IEC 60320-1 applies.

12.2.4 Replacement of fourth paragraph:

A₁ This subclause of IEC 60320-1 applies. **A₁**

12.2.5 This subclause of IEC 60320-1 applies.

12.2.6 Replacement of third paragraph:

Terminals are fitted with a 1 mm^2 conductor.

12.2.7 This subclause of IEC 60320-1 applies.

12.2.8 Replacement of third paragraph:

A solid rigid copper conductor of 1 mm^2 nominal cross-sectional area is placed in the terminal.

12.2.9 This subclause of IEC 60320-1 does not apply.

12.2.10 This subclause of IEC 60320-1 does not apply.

12.2.11 This subclause of IEC 60320-1 does not apply.

12.2.12 This subclause of IEC 60320-1 applies.

The test conductor shall have a nominal cross-sectional area of 1 mm^2 .

13 Construction

This clause of IEC 60320-1 applies amended as follows:

13.1 This subclause of IEC 60320-1 does not apply.

13.2 This subclause of IEC 60320-1 applies.

13.3 This subclause of IEC 60320-1 applies.

13.4 This subclause of IEO 60320-1 applies.

13.5 Replacement:

Contacts of connectors shall be self-adjusting so as to provide adequate contact pressure.

The self-adjustment of the contacts shall not depend upon the resiliency of the insulating material.

Compliance is checked by inspection and by using the withdrawal pull gauge shown in Figure 4 to check each individual line and neutral contact, ensuring that the hinged cover of the enclosure does not have any effect on the results of the test. During the test the connector contact shall retain the gauge for not less than 30 s when the connector is held vertically and the gauge is hanging downwards.

13.6 This subclause of IEC 60320-1 applies to all rewirable accessories.

The enclosure of rewirable accessories shall consist of more than one part and shall completely enclose the terminals and the end of the cord.

NOTE Parts of the enclosure linked together by flexible means are considered to be separate parts.

The construction shall be such that, from the point of separation of the cores, the conductors can be properly connected and that, when the accessory is assembled and wired as in normal use, there is no risk of:

- the cores being pressed against each other;
- a core coming into contact with accessible metal parts;
- a core coming into contact with other live parts.

13.7 This subclause of IEC 60320-1 applies.

13.8 This subclause of IEC 60320-1 applies to connectors and to plug connectors.

13.9 This subclause of IEC 60320-1 does not apply.

13.10 This subclause of IEC 60320-1 applies to connectors and to plug connectors.

13.11 This subclause of IEC 60320-1 does not apply.

13.12 This subclause of IEC 60320-1 applies.

Additional subclauses:

13.101 A coupler shall incorporate means for ensuring the required degree of protection against ingress of water when the inlet, plug connector and connector are in complete engagement with the complementary accessory.

Compliance is checked by inspection and by the test of 14.101.

13.102 A connector or plug connector, when fitted with a cord for normal use and when not in engagement with the complementary accessory, shall comply with clause 10 and 14.101.

13.103 Connectors shall be provided with a cover to achieve the required degree of protection against moisture when the complementary accessory is not in position. The cover shall be self-closing and shall be securely fixed to the connector.

Compliance with the requirements of 13.102 and 13.103 is checked by the tests of clauses 10, 20, 23, 28 and subclause 14.101.

13.104 Appliance inlets integrated or incorporated in the electrical appliance or equipment shall incorporate means of ensuring the required degree of protection against ingress of water, from the open interface to the terminals or terminations.

Non-rewirable plug connectors for incorporation in equipment shall be fitted with a cord of 500 mm or less (measured from the point of entry of the cord into the plug connector to the point of entry of the cord into the equipment).

Compliance is checked by inspection and the test of 14.101.

13.105 The cover spring(s), if any, of a connector when fitted with a flexible cord as in normal use, shall be sufficiently strong to rapidly close the cover when the complementary accessory is not engaged, and to withstand opening and closing in normal operation to an angle of not less than 90° and not more than 100°. The cover and associated spring(s), if any, shall withstand damage when opened to the fullest extent and shall be of corrosion-resistant materials.

Compliance is checked by inspection and by the test of 13.105.1. At the end of the test the cover shall close as required by this standard.

Compliance with the requirements for corrosion-resistant materials is checked by the test of 28.1

13.105.1 The cover shall be opened to its fullest extent and allowed to close under the influence of the associated spring(s), in sequence, 4 000 times at a rate of 15 ± 2 times per minute.

14 Moisture resistance

This clause of IEC 60320-1 applies amended as follows:

Replacement of the sixth paragraph:

The specimens are kept in the cabinet for 168 h (7 days).

Additional subclause

14.101 Accessories shall have a degree of protection higher than IPX0 according to IEC 60529.

Compliance is checked by the appropriate test of IEC 60529 and with the treatment specified below, followed immediately by wiping the surplus surface water from the accessory and carrying out the electric strength test of clause 15.

Accessories shall withstand the electric strength test and inspection shall show that water has not entered the samples to any appreciable extent and has not reached current-carrying parts.

Accessories designed for attachment by cord are tested as follows:

- a) for non-rewirable accessories, with the cord supplied;
- $\overline{A_1}$ b) for 6 A rewirable accessories with 0,75 mm² cord;
- c) for 10 A rewirable accessories with 0,75 mm² and 1 mm² cord. $\overline{A_1}$

Appliance inlets are tested when mounted in or on a suitable watertight enclosure, in accordance with the manufacturer's instructions for mounting.

Fixing screws of enclosures and covers are tightened with a torque equal to two-thirds of the appropriate torque given in clause 25. The accessories are placed in the most unfavourable position.

Connectors are tested with and also without the complementary accessory in engagement, the means for ensuring the required degree of protection against moisture (as specified in 13.102) being positioned as in normal use.

15 Insulation resistance and electric strength

This clause of IEC 60320-1 is amended as follows:

15.1 This subclause of IEC 60320-1 applies.

15.2 Replacement:

The insulation resistance is measured with a d.c. voltage of approximately 500 V applied, each measurement being made 60 s \pm 5 s after the application of the voltage.

The insulation resistance is measured:

- a) for appliance inlets with a connector in engagement, between the current-carrying pins connected together and the body;
- b) for appliance inlets with a connector in engagement, between each current-carrying pin in turn and the other, the latter being connected to the body;
- c) for connectors and plug connectors, between the current-carrying pins or contacts connected together and the body;
- d) for connectors and plug connectors, between each current-carrying pin or contact in turn and the other, the latter being connected to the body;

e) for rewirable connectors and plug connectors, between any metal part of the cord anchorage, excluding clamping screws, and a metal rod, of the maximum diameter of the cord, inserted in its place.

$\overline{A_1}$ NOTE The maximum diameters of the cords are:

Type of cord	No. of cores and nominal cross-section mm ²	Max diameter mm
60227 IEC 53	2 \times 0,75	7,2
	2 \times 1,0	7,5
60245 IEC 53	2 \times 0,75	7,4
	2 \times 1,0	8,0

$\overline{A_1}$

The insulation resistance shall be not less than 5 M Ω .

The term "body" used in items a), b), c) and d) above includes all accessible metal parts, fixing screws, external assembly screws or the like and metal foil in contact with the outer surface of external parts of insulating material, including the engagement face of connectors [items c) and d)].

The metal foil is wrapped round the outer surface of external parts of insulating material; however, it is not pressed into openings.

15.3 Replacement:

A voltage of substantially sine-wave form with a frequency of 50 Hz to 60 Hz is applied for a period of not less than 1 min between the parts as indicated in 15.2.

The value of the test voltage is:

- a) 4 000 V \pm 60 V between current-carrying parts and the body;
- b) 2 000 V \pm 60 V between all other parts.

Initially, not more than half the prescribed voltage is applied, then it is raised rapidly to the full value. No flashover or breakdown shall occur during the test.

NOTE 1 The high-voltage transformer used for the test must be so designed that, when the output terminals are short-circuited after the output voltage has been adjusted to the appropriate test voltage, the output current is at least 200 mA. The overcurrent relay must not trip when the output current is less than 100 mA.

NOTE 2 Care is taken that the r.m.s. value of the test voltage applied is measured within \pm 3 %.

NOTE 3 Glow discharges without drop in voltage are neglected.

16 Forces necessary to insert and to withdraw the connector

This clause of IEC 60320-1 applies amended as follows:

16.1 This subclause of IEC 60320-1 applies.

16.2 This subclause of IEC 60320-1 applies.

Additional subclause:

16.101 A retaining catch shall be provided to prevent inadvertent disconnection of the accessories when engaged. The retaining catch shall operate correctly. It shall be possible to insert or withdraw the connector and operate the retaining catch with two hands without difficulty.

Compliance is checked by manual operation and by the following test. During this test the connection between the accessories shall be maintained during the application of the principal weight and shall disconnect when the supplementary weight is applied.

The maximum and minimum forces necessary to separate the coupler are determined by means of an apparatus as shown in Figure 3. This apparatus comprises a mounting plate (A) and an appliance coupler wired as in normal use (B), mounted so that the coupler hangs vertically with the plug connector or appliance inlet downwards.

For rewirable appliance couplers using cord anchorages with clamping screws, these screws are tightened with a torque as given in **25.1**.

The maximum and minimum separation forces provided by the retaining device are measured by inserting the connector into the plug connector or appliance inlet to the full depth. A carrier (C), with a principal weight (D) and a supplementary weight (E), is attached to the cord (F). The forces exerted by these components are given in the table below. The principal weight is hung on without jolting the connector and the supplementary weight is allowed to fall from a height of $50 \text{ mm} \pm 2,5 \text{ mm}$ onto the principal weight.

Component	Force N
Carrier (C) and principal weight (D)	60 ± 1
Supplementary weight (E)	30 ± 1

17 Operation of contacts

This clause of IEC 60320-1 applies.

18 Resistance to heating of appliance couplers for hot conditions or very hot conditions

This clause of IEC 60320-1 does not apply.

19 Breaking capacity

This clause of IEC 60320-1 applies amended as follows:

Replacement of fourth paragraph:

The appliance inlet or plug connector is positioned so that the plane through the axes of the pins is horizontal and the cover removed or held open.

20 Normal operation

This clause of IEC 60320-1 applies amended as follows:

Addition:

The connector is tested with the cover removed or held open.

21 Temperature rise

This clause of IEC 60320-1 is replaced as follows:

Contacts and other current-carrying parts shall be so designed as to prevent excessive temperature rise due to the passage of current.

Compliance is checked by the following test.

A1) *Rewirable connectors and plug connectors are fitted with thermoplastic-insulated cords with a minimum length of 500 mm and a nominal cross-sectional area as follows:*

- for 6 A accessories – $0,75 \text{ mm}^2$,
- for 10 A accessories – 1 mm^2 ,

*the terminal screws being tightened with two-thirds of the torque specified in the appropriate column of the table of 25.1. Non-rewirable connectors and plug connectors are tested with the cord as delivered having a minimum length of 500 mm. **A1***

The connector is inserted into a plug connector complying with standard sheet B, except that pins shall have minimum dimensions with a tolerance of ${}^{+0,02}_0 \text{ mm}$, the distance between pin centres having the value specified in the standard sheet.

NOTE Minimum dimensions implies the dimensions as given in standard sheet B with the stated negative tolerance applied.

Plug connectors are tested with a connector complying with this standard.

An alternating current of 1,25 times rated current, ${}^{0}_{-0,5} \text{ A}$ is passed through the current-carrying contacts for 1 h, or until steady conditions are attained, whichever is the longer.

The temperature is determined by means of thermocouples, which are so chosen and positioned that they have a negligible effect on the temperature being determined.

The temperature rise of terminals or terminations shall not exceed 45 K.

22 Cords and their connection

This clause of IEC 60320-1 applies amended as follows:

22.1 Replacement:

Non-rewirable accessories shall be provided with a cord complying either with type 60227 IEC 53 or with type 60245 IEC 53 in accordance with the following table.

A1)

Type of coupler	Nominal cross-section mm ²
Plug connector	0,75 – 1, as per appliance manufacturer's instructions
6 A connector	0,75
10 A connector with 2 m or less of attached cord	0,75 or 1
10 A connector with more than 2 m of attached cord	1

Compliance is checked by inspection. **A1)**

22.2 Amendment:

This clause of IEC 60320-1 applies to connectors and to plug connectors.

22.3 Replacement:

For rewirable accessories:

- it shall be clear how the relief from strain and the prevention of twisting is intended to be effected;
- the cord anchorage, or at least part of it, shall be integral with or fixed to one of the other component parts of the accessory;
- makeshift methods, such as tying the cord into a knot or tying the ends with string, shall not be used;
- cord anchorages shall be suitable for the different types of cord which may be connected, and their effectiveness shall not depend upon the assembly of the parts of the body;
- cord anchorages shall be of insulating material or be provided with an insulating lining fixed to the metal parts;
- it shall not be possible for the cord to touch the clamping screws of the cord anchorage if these screws are accessible with the standard test finger shown in Figure 10 of IEC 60320-1 or are electrically connected to accessible metal parts.

Compliance with the requirements of **22.2** and **22.3** is checked by inspection and by a pull test in an apparatus similar to that shown in Figure 16 of IEC 60320-1, followed by a torque test.

Non-rewirable accessories are tested with the cord as delivered. Rewirable accessories are tested with a cord type 60227 IEC 53 or type 60245 IEC 53 with nominal cross-sectional area of 0,75 mm² and 1 mm².

Conductors of the cord of rewirable accessories are introduced into the terminals, and the terminal screws are tightened just sufficiently to prevent the conductors from easily changing their position.

*The cord anchorage is used in the normal way, clamping screws being tightened with a torque equal to two-thirds of the appropriate torque specified in the appropriate column of the table of **25.1**. After reassembly of the specimen, the component parts shall fit snugly and it shall not be possible to push the cord into the accessory to any appreciable extent.*

The specimen is fixed in the test apparatus so that the axis of the cord is vertical where it enters the accessory.

The cord is then subjected 25 times to a pull of 150 N ± 3 N. The pulls are applied without jerks, each time for a minimum of 1 s.

Immediately afterwards, the cord is subjected for 60 s ± 5 s to a minimum torque of 0,15 Nm applied adjacent to the entry of the flexible cord.

During the tests, the cord shall not be damaged.

After the tests, the cord shall not have been displaced by more than 2 mm. For rewirable accessories, the ends of the conductors shall not have moved noticeably in the terminals; for non-rewirable accessories, there shall be no break in the electrical connections.

For the measurement of the longitudinal displacement, a mark is made on the cord before starting the test while subjecting it to a preliminary pull of the value specified; the mark is made at a distance of approximately 20 mm from the end of the accessory or the cord guard. If for non-rewirable accessories, there is no definite end to the accessory or the cord guard, an additional mark is made on the body, from which the distance to the other mark is measured.

After the tests, the displacement of the mark on the cord in relation to the accessory or the cord guard is measured while the cord is subjected to a pull of the value specified.

22.4 Replacement:

Accessories shall be so designed that the cord cannot be subjected to excessive bending where it enters the accessory.

Compliance is checked by inspection and the following test.

Accessories are subjected to a flexing test in an apparatus which has an oscillating member similar to that shown in Figure 17 of IEC 60320-1.

Rewirable connectors and plug connectors are fitted with a 1 mm^2 cord, which has an appropriate length. The cord guard, if any, is put in place.

Non-rewirable connectors are tested with the cord as delivered.

The specimen is fixed to the oscillating member of the apparatus so that, when it is at the middle of its travel, the axis of the cord, where it enters the accessory, is vertical and passes through the axis of oscillation.

The oscillating member is, by variation of distance d shown in Figure 17 of IEC 60320-1, so positioned that the cord makes the minimum lateral movement when the oscillating member of the test apparatus is moved over its full travel.

The cord is loaded so that the force applied is $20 \text{ }_{-2}^0 \text{ N}$.

A current of $10 \text{ A} \pm 0,1 \text{ A}$ is passed through the conductors, the voltage between them being equal to the rated voltage.

The oscillating member is moved backwards and forwards through an angle of 90° ($45^\circ \pm 3^\circ$ on either side of the vertical), the number of flexings being 20 000 for rewirable and non-rewirable accessories and the rate of flexing being 60 ± 1 per minute.

NOTE A flexing is one movement, either backwards or forwards. Accessories are rotated about the axis of the cord, through 90° in the oscillating member after half the required number of flexings.

The test shall be carried out on accessories not subjected to any other test.

During the test there shall be no interruption of the test current, and no short-circuit between conductors. A short-circuit between the conductors of the cord is considered to occur if the current attains a value equal to twice the rated current of the accessory.

After the test, the specimen shall show no damage within the meaning of this standard, the guard, if any, shall not have separated from the body and the insulation of the cord shall show no sign of abrasion or wear; moreover, for non-rewirable accessories, broken strands of the conductors shall not have pierced the insulation so as to become accessible.

23 Mechanical strength

This clause of IEC 60320-1 applies amended as follows:

23.1 Replacement:

Accessories shall have adequate mechanical strength.

Compliance is checked:

- for connectors, by the tests of **23.2**, **23.3** and **23.7**;
- for plug connectors, by the test of **23.2**;
- for appliance inlets, by the test of **23.5**.

NOTE Shrouds of appliance inlets designed for flush-mounting in an appliance or other equipment are not subjected to the test of **23.5**.

Amended 23.2 This subclause of IEC 60320-1 applies, amended as follows:

The number of falls shall be 500 with the connector and plug connector connected together. Rewirable accessories shall be fitted with a cord type 60227 IEC 53 having a nominal cross-sectional area as follows:

- for 6 A accessories – $0,75 \text{ mm}^2$;
- for 10 A accessories – 1 mm^2 . **Amended**

23.3 This subclause of IEC 60320-1 applies.

23.4 This subclause of IEC 60320-1 does not apply.

23.5 Replacement of first paragraph:

Appliance inlets designed for surface-mounting and having a shroud of insulating material, other than elastomeric, thermoplastic or other resilient material are tested by means of the spring-operated impact test apparatus shown in Figure 21 of IEC 60320-1. Before commencing the test, appliance inlets with enclosures of resilient or thermoplastic material, with their bases or cords, are placed in a refrigerator at a temperature of $-5 \text{ }^\circ\text{C} \pm 2 \text{ }^\circ\text{C}$ for at least 16 h. When removed from the refrigerator, the appliance inlets are immediately subjected to the following test. Blows are applied to the specimen by means of the spring-operated impact test apparatus shown in Figure 21 of IEC 60320-1.

Replacement of fifth paragraph:

The hammer head has a hemispherical face of polyamide having a Rockwell hardness of HR 100 and a radius of $10 \text{ }_{-0,01}^0 \text{ mm}$. It is fixed to the hammer shaft in such a way that the distance from its tip to the plane of the front of the cone when the striking element is on the point of release is 28 mm.

Replacement of seventh paragraph:

The hammer spring is adjusted so that the product of the compression, in millimetres, and the force exerted, in newtons, equals 2 000, the compression being approximately 28 mm. With this adjustment, the impact energy is $1 J \pm 0,05 J$.

Replacement of twelfth paragraph:

The specimen is rigidly supported and three blows are applied to every point that is likely to be weak.

Replacement of twelfth paragraph:

After the test, the specimens shall show no damage within the meaning of this standard. In particular, live parts shall not have become accessible and the enclosure shall show no cracks visible to the naked eye. Appliance inlets shall comply with 14.101.

23.6 This subclause of IEC 60320-1 does not apply.

23.7 This subclause of IEC 60320-1 applies.

24 Resistance to heat and ageing

This clause of IEC 60320-1 applies amended as follows:

24.1.1 This subclause of IEC 60320-1 applies.

24.1.2 This subclause of IEC 60320-1 applies.

24.1.3 Amendment:

This subclause of IEC 60320-1 applies to connectors and plug connectors.

24.2 This subclause of IEC 60320-1 applies.

25 Screws, current-carrying parts and connections

This clause of IEC 60320-1 applies amended as follows:

25.1 This subclause of IEC 60320-1 applies.

25.2 This subclause of IEC 60320-1 applies.

25.3 This subclause of IEC 60320-1 applies.

25.4 This subclause of IEC 60320-1 applies.

25.5 This subclause of IEC 60320-1 applies.

25.6 This subclause of IEC 60320-1 applies.

25.7 This subclause of IEC 60320-1 applies.

25.8 This subclause of IEC 60320-1 does not apply.

26 Creepage distances, clearances and distances through insulation

This clause of IEC 60320-1 applies amended as follows:

Addition:

A₁ Accessories shall be tested with a flexible conductor having a nominal cross-sectional area as follows:

— 6 A accessories – 0,75 mm² cord ;

— 10 A accessories – 1 mm² cord . **A₁**

27 Resistance of insulating material to heat, fire and tracking

This clause of IEC 60320-1 applies amended as follows:

27.1 This subclause of IEC 60320-1 applies.

27.2 Replacement:

Insulating parts supporting or in contact with live parts of appliance couplers shall be of a material resistant to tracking.

Compliance is checked, for materials other than ceramic, by the test described in IEC 60112. The test need not be made if the creepage distances have at least twice the values specified in clause 26.

27.2.1 Replacement:

Clause 3 of IEC 60112 is applicable.

NOTE If it is not possible to carry out the test on a sample 3 mm thick, it is permitted to stack specimens to reach the 3 mm thickness value or else to use a plaque of the identical material 3 mm thick.

27.2.2 This subclause of IEC 60320-1 applies.

27.2.3 This subclause of IEC 60320-1 applies.

27.2.4 This subclause of IEC 60320-1 applies.

28 Resistance to rusting

This clause of IEC 60320-1 applies.

29 Electromagnetic compatibility (EMC) requirements

This clause of IEC 60320-1 applies.

Annex A (informative)

**Routine tests for factory wired appliance couplers related to safety
(protection against electric shock and correct polarity)**

This annex of IEC 60320-1 applies.

FEUILLE DE NORME A
 PRISE MOBILE 10 A 250 V
 POUR CONDITIONS FROIDES
 POUR MATÉRIELS DE LA CLASSE II, IPX4

STANDARD SHEET A
 10 A 250 V CONNECTOR
 FOR COLD CONDITIONS
 FOR CLASS II EQUIPMENT IPX4

Dimensions en millimètres

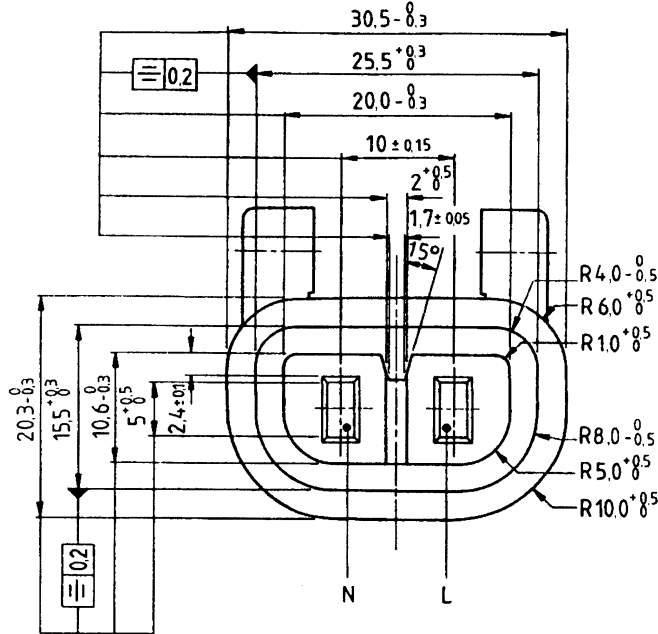

Dimensions in millimetres

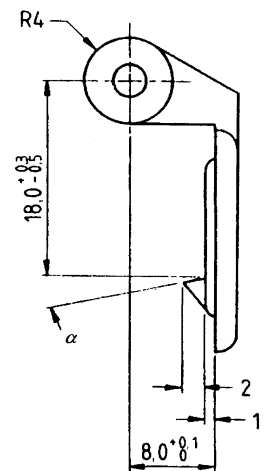
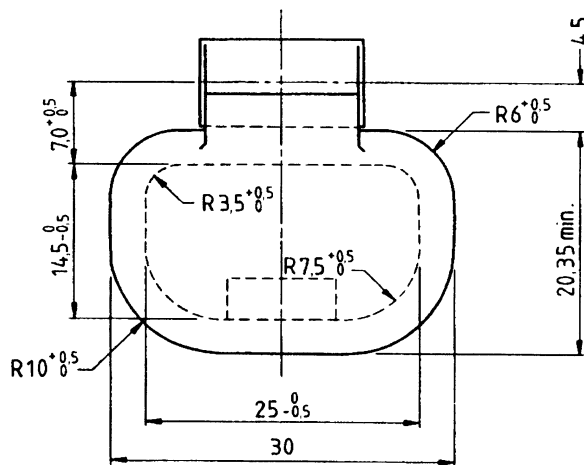
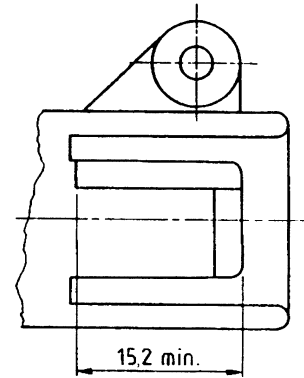
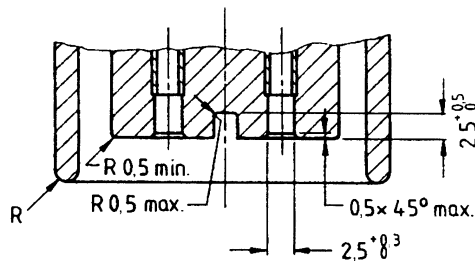
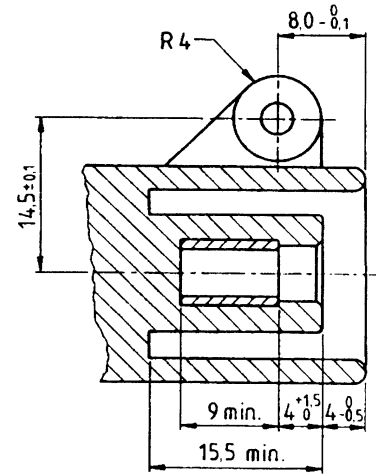

IEC 1350/98

Les dessins ne préjugent pas des détails non cotés. Les dimensions sans tolérances sont seulement des recommandations.

The sketches are not intended to govern design, except as regards the dimensions shown. Dimensions without tolerances are only recommended.

L'angle α est ajusté de façon à être conforme aux prescriptions données en 13.105.

Angle α is adjusted to suit the requirements of 13.105.

FEUILLE DE NORME B
 SOCLE DE CONNECTEUR 10 A 250 V
 POUR CONDITIONS FROIDES
 POUR MATÉRIELS DE LA CLASSE II, IPX4

STANDARD SHEET B
 10 A 250 V APPLIANCE INLET
 FOR COLD CONDITIONS
 FOR CLASS II EQUIPMENT IPX4

Dimensions en millimètres

Dimensions in millimetres

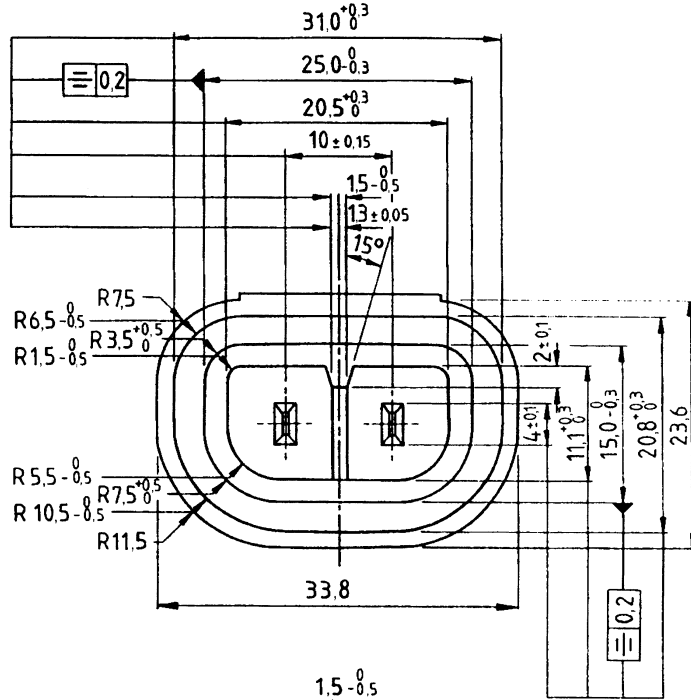
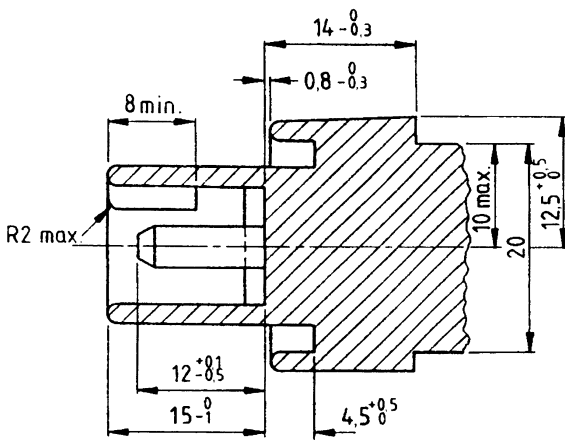

Variantes pour la forme des broches
 Alternatives for the shape of pins

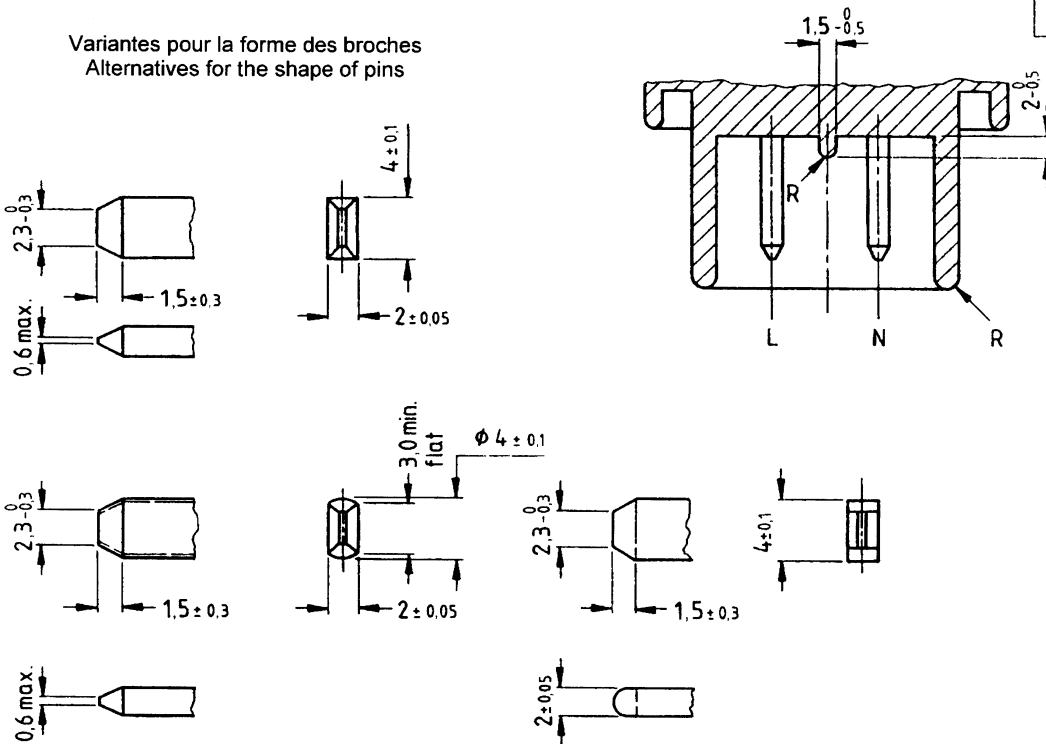

IEC 1 351/98

Les dessins ne préjugent pas des détails non cotés. Les dimensions sans tolérances sont seulement des recommandations.

The sketches are not intended to govern design, except as regards the dimensions shown. Dimensions without tolerances are only recommended.

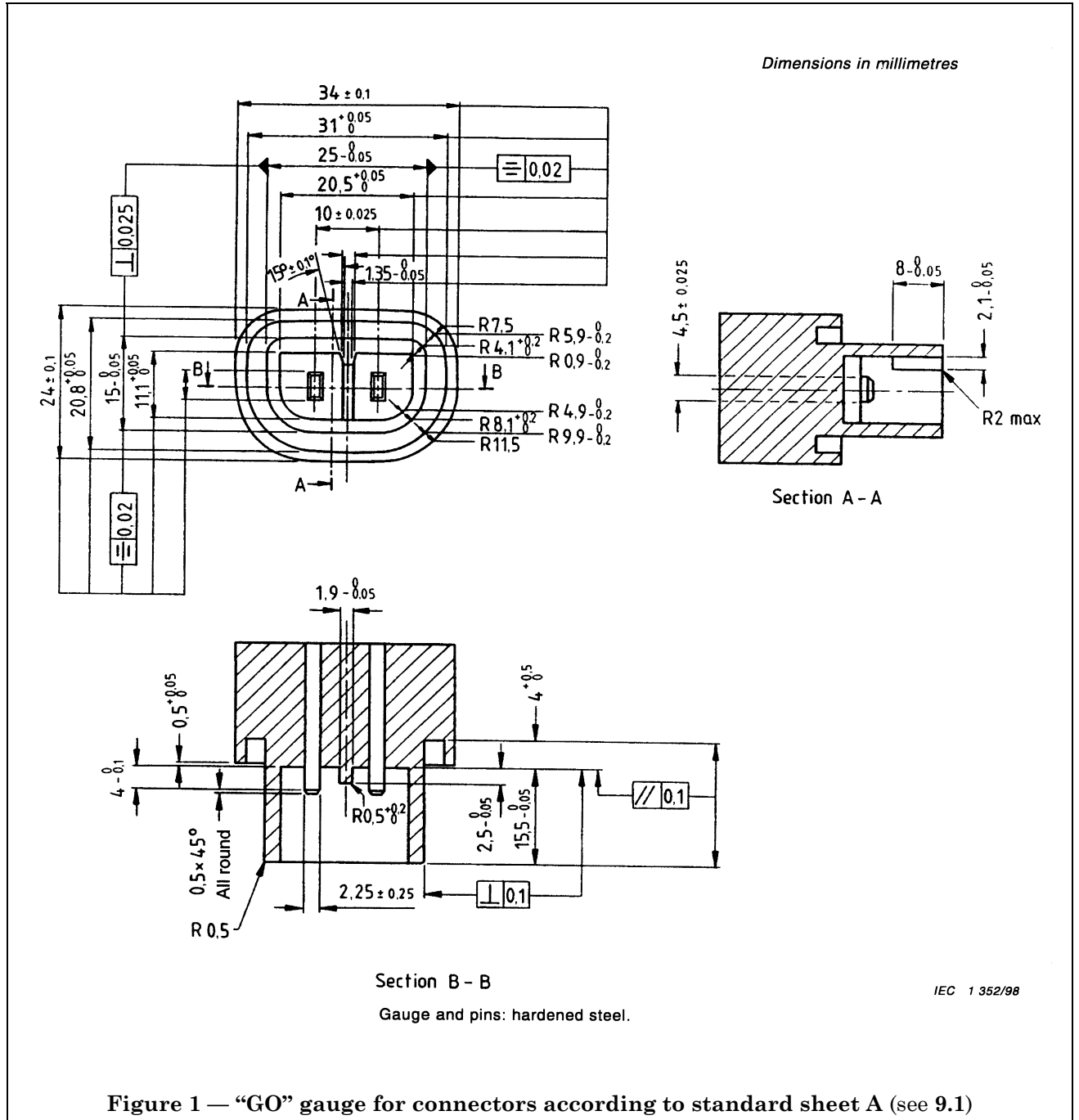

Dimensions in millimetres

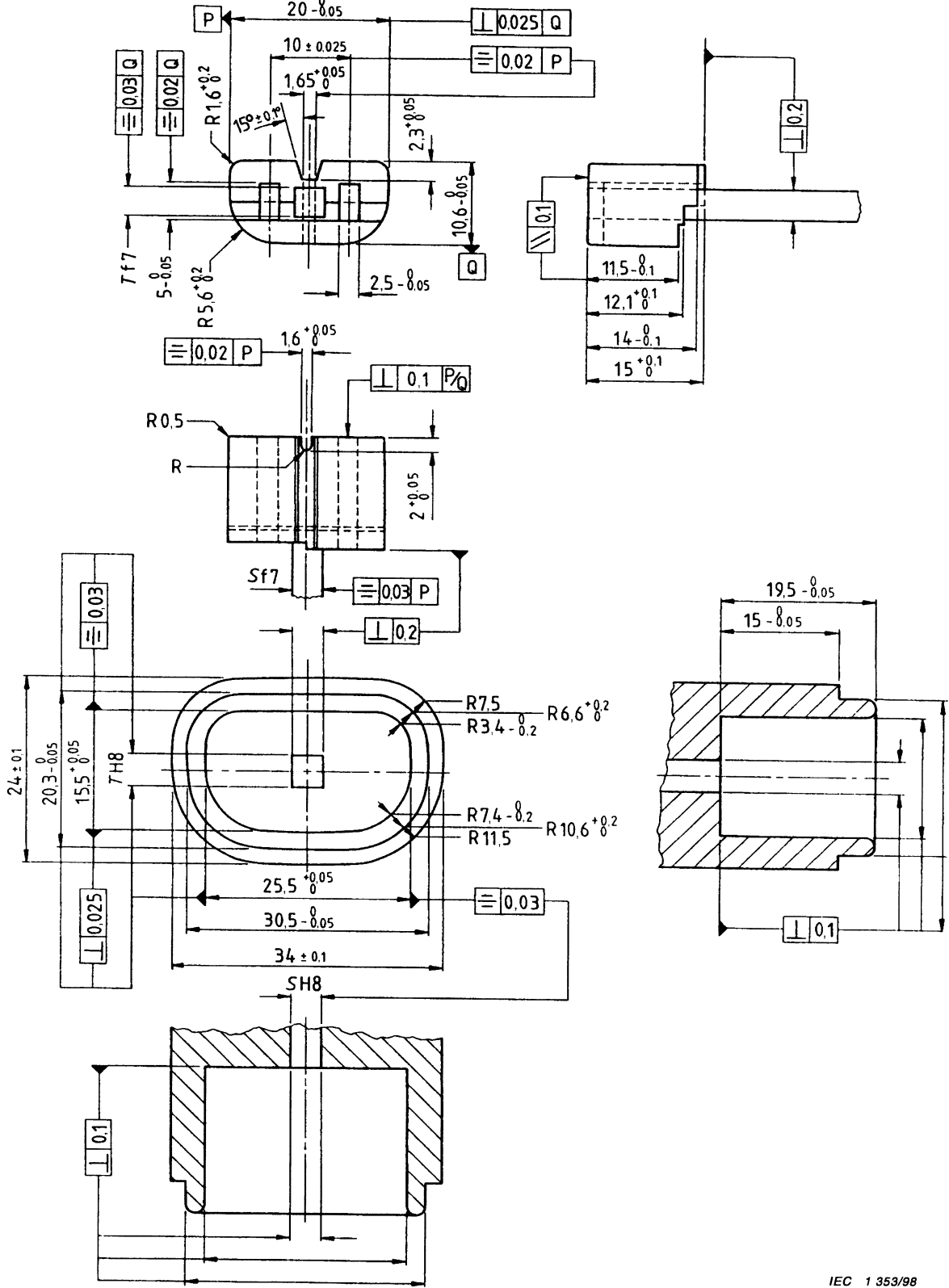

Gauge and bar: hardened steel.

Nominal values of *S* and *T* of the bar and hole are left free but tolerances are to be respected.

Figure 2 — Primary and supplementary “GO” gauge for appliance inlets according to standard sheet B (see 9.1)

IEC 1 353/98

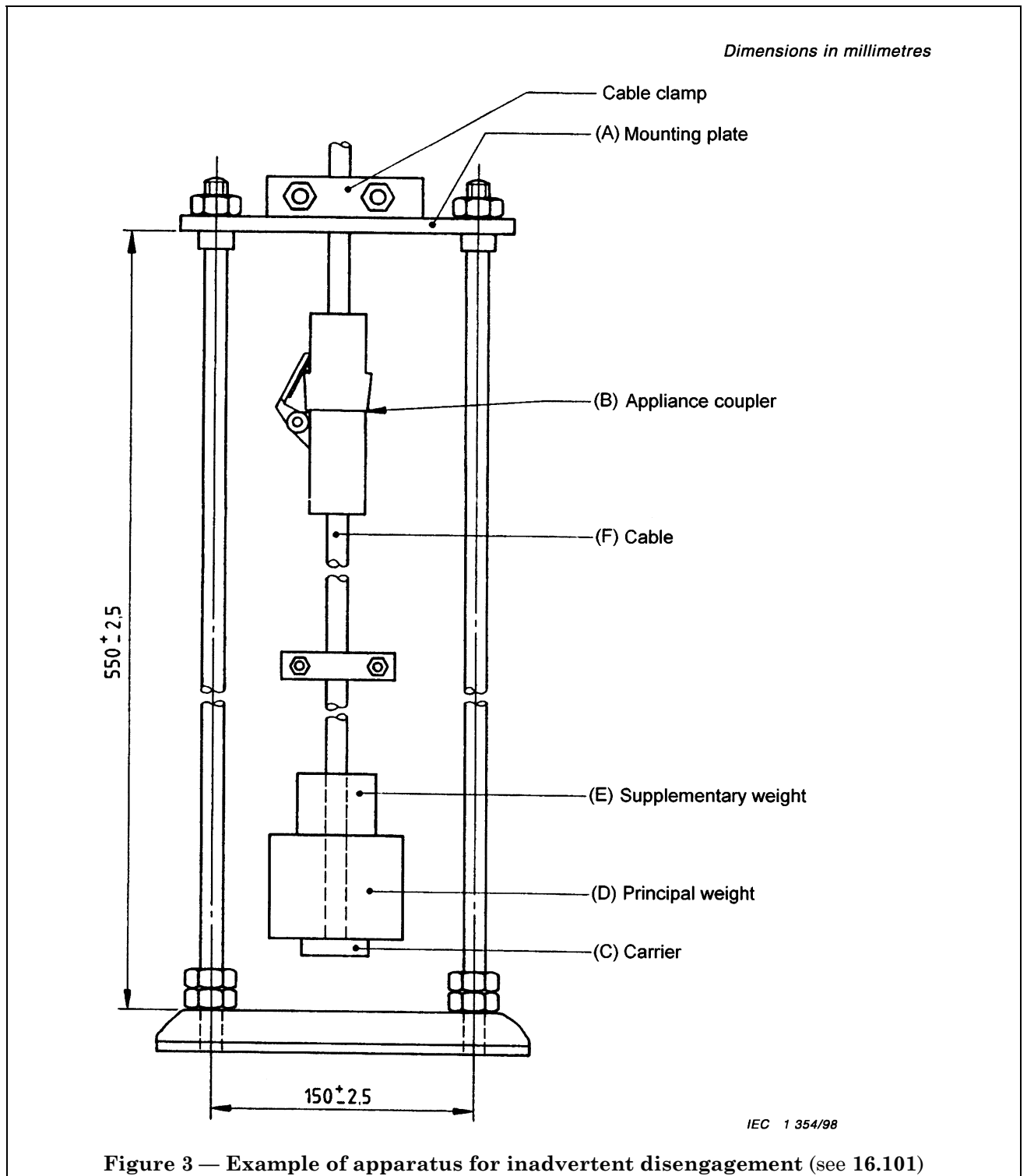

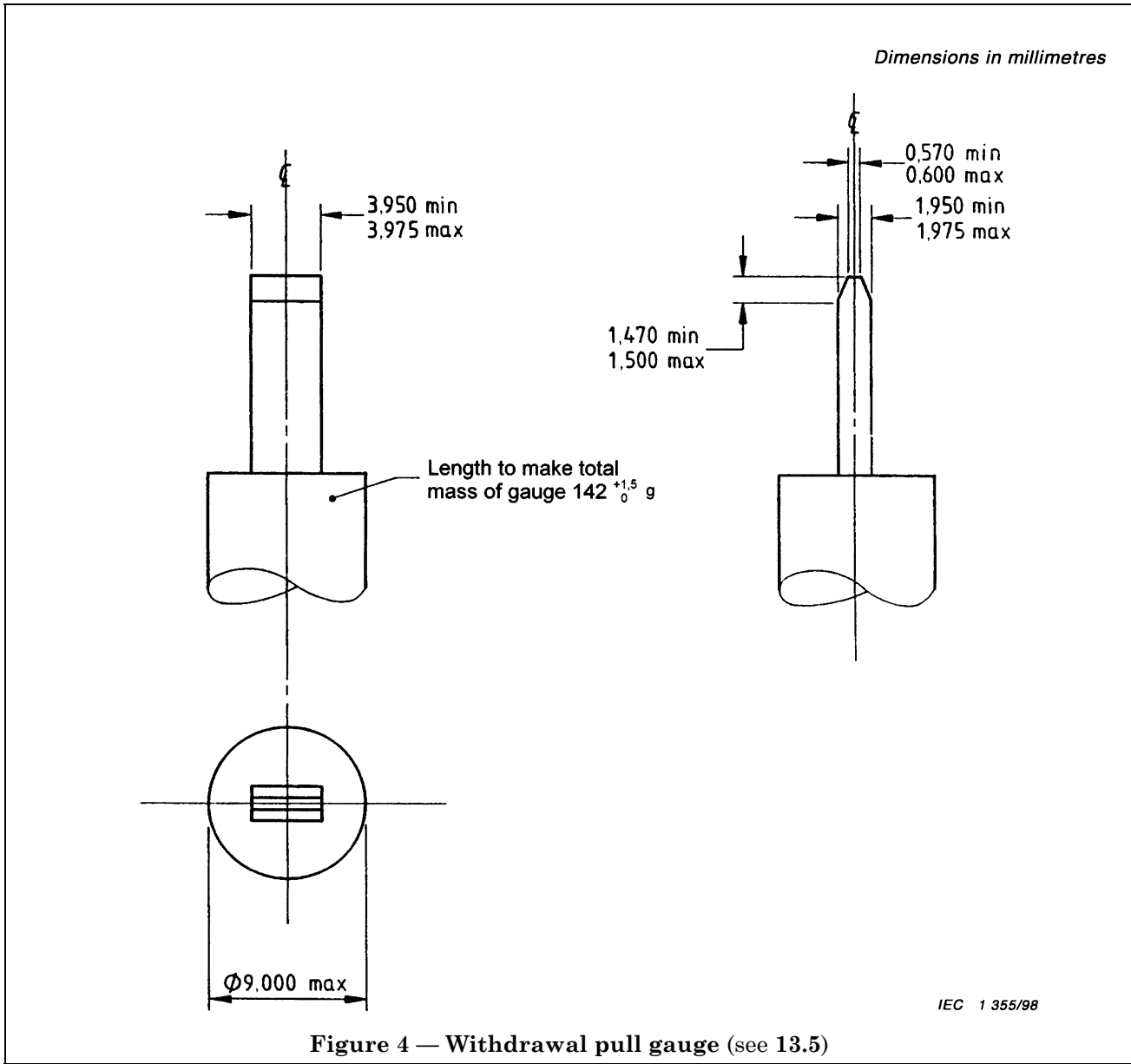

Annex ZA (normative)**Normative references to international publications with their corresponding European publications**

Addition:

Publication	Year	Title	EN/HD	Year
IEC 60320-1 (mod)	1994	Appliance couplers for household and similar general purposes Part 1: General requirements	EN 60320-1	1996
IEC 60529	1989	Degrees of protection provided by enclosures (IP Code)	EN 60529 + corr. May	1991 1993

BSI — British Standards Institution

BSI is the independent national body responsible for preparing British Standards. It presents the UK view on standards in Europe and at the international level. It is incorporated by Royal Charter.

Revisions

British Standards are updated by amendment or revision. Users of British Standards should make sure that they possess the latest amendments or editions.

It is the constant aim of BSI to improve the quality of our products and services. We would be grateful if anyone finding an inaccuracy or ambiguity while using this British Standard would inform the Secretary of the technical committee responsible, the identity of which can be found on the inside front cover.
Tel: +44 (0)20 8996 9000. Fax: +44 (0)20 8996 7400.

BSI offers members an individual updating service called PLUS which ensures that subscribers automatically receive the latest editions of standards.

Buying standards

Orders for all BSI, international and foreign standards publications should be addressed to Customer Services. Tel: +44 (0)20 8996 9001.
Fax: +44 (0)20 8996 7001. Email: orders@bsi-global.com. Standards are also available from the BSI website at <http://www.bsi-global.com>.

In response to orders for international standards, it is BSI policy to supply the BSI implementation of those that have been published as British Standards, unless otherwise requested.

Information on standards

BSI provides a wide range of information on national, European and international standards through its Library and its Technical Help to Exporters Service. Various BSI electronic information services are also available which give details on all its products and services. Contact the Information Centre.
Tel: +44 (0)20 8996 7111. Fax: +44 (0)20 8996 7048. Email: info@bsi-global.com.

Subscribing members of BSI are kept up to date with standards developments and receive substantial discounts on the purchase price of standards. For details of these and other benefits contact Membership Administration.
Tel: +44 (0)20 8996 7002. Fax: +44 (0)20 8996 7001.
Email: membership@bsi-global.com.

Information regarding online access to British Standards via British Standards Online can be found at <http://www.bsi-global.com/bsonline>.

Further information about BSI is available on the BSI website at <http://www.bsi-global.com>.

Copyright

Copyright subsists in all BSI publications. BSI also holds the copyright, in the UK, of the publications of the international standardization bodies. Except as permitted under the Copyright, Designs and Patents Act 1988 no extract may be reproduced, stored in a retrieval system or transmitted in any form or by any means – electronic, photocopying, recording or otherwise – without prior written permission from BSI.

This does not preclude the free use, in the course of implementing the standard, of necessary details such as symbols, and size, type or grade designations. If these details are to be used for any other purpose than implementation then the prior written permission of BSI must be obtained.

Details and advice can be obtained from the Copyright & Licensing Manager.
Tel: +44 (0)20 8996 7070. Fax: +44 (0)20 8996 7553.
Email: copyright@bsi-global.com.