



BSI Standards Publication

# Vacuum cleaners for household use

Part 1: Dry vacuum cleaners — Methods for measuring the performance (IEC 60312-1:2010, modified + A1:2011, modified)

### National foreword

This British Standard is the UK implementation of EN 60312-1:2017. It is derived from IEC 60312-1:2010, incorporating amendment 1:2011. It supersedes BS EN 60312-1:2013 which will be withdrawn on 2 January 2020.

The start and finish of text introduced or altered by amendment is indicated in the text by tags. Tags indicating changes to IEC text carry the number of the IEC amendment. For example, text altered by IEC amendment 1 is indicated by  $\boxed{A_1}$   $\boxed{A_1}$ .

The CENELEC common modifications have been implemented at the appropriate places in the text. The start and finish of each common modification is indicated in the text by tags  $\boxed{C}$   $\boxed{C}$ .

The UK participation in its preparation was entrusted by Technical Committee CPL/59, Performance of household electrical appliances, to Subcommittee CPL/59/6, Floor treatment appliances.

A list of organizations represented on this subcommittee can be obtained on request to its secretary.

This publication does not purport to include all the necessary provisions of a contract. Users are responsible for its correct application.

© The British Standards Institution 2017.

Published by BSI Standards Limited 2017

ISBN 978 0 580 94744 5

ICS 97.080

### Compliance with a British Standard cannot confer immunity from legal obligations.

This British Standard was published under the authority of the Standards Policy and Strategy Committee on 30 April 2017.

### Amendments/corrigenda issued since publication

Date	Text affected
------	---------------

---

EUROPEAN STANDARD

**EN 60312-1**

NORME EUROPÉENNE

EUROPÄISCHE NORM

February 2017

ICS 97.080

Supersedes EN 60312-1:2013

English Version

**Vacuum cleaners for household use - Part 1: Dry vacuum  
cleaners - Methods for measuring the performance  
(IEC 60312-1:2010 , modified + A1:2011 , modified)**

Aspirateurs de poussière à usage domestique - Partie 1:  
Aspirateurs a sec - Méthodes de mesure de l'aptitude à la  
fonction  
(IEC 60312-1:2010 , modifiée + A1:2011 , modifiée)

Staubsauger für den Hausgebrauch - Teil 1: Trockensauger  
- Prüfverfahren zur Bestimmung der  
Gebrauchseigenschaften  
(IEC 60312-1:2010 , modifiziert + A1:2011 , modifiziert)

This European Standard was approved by CENELEC on 2017-01-02. CENELEC members are bound to comply with the CEN/CENELEC Internal Regulations which stipulate the conditions for giving this European Standard the status of a national standard without any alteration.

Up-to-date lists and bibliographical references concerning such national standards may be obtained on application to the CEN-CENELEC Management Centre or to any CENELEC member.

This European Standard exists in three official versions (English, French, German). A version in any other language made by translation under the responsibility of a CENELEC member into its own language and notified to the CEN-CENELEC Management Centre has the same status as the official versions.

CENELEC members are the national electrotechnical committees of Austria, Belgium, Bulgaria, Croatia, Cyprus, the Czech Republic, Denmark, Estonia, Finland, Former Yugoslav Republic of Macedonia, France, Germany, Greece, Hungary, Iceland, Ireland, Italy, Latvia, Lithuania, Luxembourg, Malta, the Netherlands, Norway, Poland, Portugal, Romania, Serbia, Slovakia, Slovenia, Spain, Sweden, Switzerland, Turkey and the United Kingdom.



European Committee for Electrotechnical Standardization  
Comité Européen de Normalisation Electrotechnique  
Europäisches Komitee für Elektrotechnische Normung

**CEN-CENELEC Management Centre: Avenue Marnix 17, B-1000 Brussels**

## European foreword

This document (EN 60312-1:2017) consists of the text of IEC 60312-1:2010+A1:2011 prepared by SC 59F, "Surface cleaning appliances", of IEC/TC 59, "Performance of household and similar electrical appliances", together with the common modifications prepared by CLC/TC 59X, "Performance of household and similar electrical appliances".

The following dates are fixed:

- latest date by which this document has to be implemented at national level by publication of an identical national standard or by endorsement (dop) 2018-01-02
- latest date by which the national standards conflicting with this document have to be withdrawn (dow) 2020-01-02

The common modifications of EN 60312-1:2013 still apply. They are partly modified.

Clauses, subclauses, notes, tables and figures which are additional to those in IEC 60312-1:2010 are prefixed "Z".

This European Standard also specifies, as far as necessary, the test methods which shall be applied in accordance with the standardisation mandate M540 related to Council Directive 92/75 of the European Commission.

This document has been prepared under a mandate given to CENELEC by the European Commission and the European Free Trade Association, and supports essential requirements of EU Directive(s).

For the relationship with EU Directive(s) see informative Annex ZZA and ZZB, which are integral parts of this document.

### Endorsement notice

The text of the International Standard IEC 60312-1:2010+A1:2011 was approved by CENELEC as a European Standard with agreed common modifications.

**Annex ZZA**  
(informative)

**Relationship between this European Standard and the energy labelling requirements of Commission Delegated Regulation (EU) No 665/2013 aimed to be covered**

This European standard has been prepared under a Commission’s standardisation request ‘M/540’ / ‘C(2015) 8753 final’ to provide one voluntary means of conforming to the energy labelling requirements of Commission Delegated Regulation (EU) No 665/2013 of 3 May 2013 supplementing Directive 2010/30/EU of the European Parliament and of the Council with regard to energy labelling of energy labelling of vacuum cleaners [OJEU L192 of 13 July 2013].

Once this standard is cited in the Official Journal of the European Union under that Regulation, compliance with the normative clauses of this standard given in Table ZZA.1 confers, within the limits of the scope of this standard, a presumption of conformity with the corresponding energy labelling requirements of that Regulation and associated EFTA Regulations.

**Table ZZA.1 – Correspondence between this European Standard and Commission Delegated Regulation (EU) No 665/2013 of [3 May 2013] supplementing Directive 2010/30/EU of the European Parliament and of the Council with regard to energy labelling of k vacuum cleaners [OJEU L192 of 13 July 2013] and Commission’s standardisation request ‘M/540’ / ‘C(2015) 8753 final’**

Energy labelling requirements of Regulation No 665/2013 [OJEU L192]	Clause(s) / sub-clause(s) of this EN	Remarks / Notes
annual energy consumption	6.16	
rated input power		see list of harmonised standards (OJEU 2014/C 272/06) EN 60335-2-2:2010/A11:2012 EN 60335-2-2:2010/A1:2013 IEC 60335-2-2:2009/A1:2012
dust pick up on carpet (dpu <sub>c</sub> )	5.3 in conjunction with 6.Z1.2	
dust pick up on hard floor (dpu <sub>hf</sub> )	5.2	
dust re-emission	5.11	
sound power level	6.15	The reference to verification given in Annex ZZ of EN 60704-2-1:2015 shall not apply.

WARNING 1: Presumption of conformity stays valid only as long as a reference to this European Standard is maintained in the list published in the Official Journal of the European Union. Users of this standard should consult frequently the latest list published in the Official Journal of the European Union.

WARNING 2: Other Union legislation may be applicable to the products falling within the scope of this standard.

**Annex ZZB**  
(informative)

**Relationship between this European Standard and the ecodesign requirements of Commission Regulation (EU) No 666/2013 aimed to be covered**

This European standard has been prepared under a Commission's standardisation request 'M/540' / 'C(2015) 8753 final' to provide one voluntary means of conforming to the ecodesign requirements of Commission Regulation (EU) No 666/2013 of 8 July 2013 implementing Directive 2009/125/EC of the European Parliament and of the Council with regard to ecodesign requirements for vacuum cleaners [OJEU L 192 of 13 July 2013].

Once this standard is cited in the Official Journal of the European Union under that Regulation, compliance with the normative clauses of this standard given in Table ZZB.1 confers, within the limits of the scope of this standard, a presumption of conformity with the corresponding ecodesign requirements of that Regulation and associated EFTA Regulations.

**Table ZZB.1 – Correspondence between this European Standard and Commission Regulation (EU) No 666/2013 of 8 July 2013 implementing Directive 2009/125/EC of the European Parliament and of the Council with regard to ecodesign requirements for vacuum cleaners [OJEU L 192 of 13 July 2013] and Commission's standardisation request 'M/540' / 'C(2015) 8753 final'**

Ecodesign requirements of Regulation No 666/2013 [OJEU L 192]	Clause(s) / sub-clause(s) of this EN	Remarks / Notes
annual energy consumption	6.16	
rated input power		see list of harmonised standards (OJEU 2014/C 272/06) EN 60335-2-2:2010/A11:2012 EN 60335-2-2:2010/A1:2013 IEC 60335-2-2:2009/A1:2012
dust pick up on carpet (dpu <sub>c</sub> )	5.3 in conjunction with 6.Z1.2	
dust pick up on hard floor (dpu <sub>hf</sub> )	5.2	
dust re-emission	5.11	
sound power level	6.15	The reference to verification given in Annex ZZ of EN 60704-2-1:2015 shall not apply.
durability of hose	6.9	
operational motor lifetime	6.Z17	

WARNING 1: Presumption of conformity stays valid only as long as a reference to this European Standard is maintained in the list published in the Official Journal of the European Union. Users of this standard should consult frequently the latest list published in the Official Journal of the European Union.

WARNING 2: Other Union legislation may be applicable to the products falling within the scope of this standard.

## CONTENTS

FOREWORD .....	7
<b>A1</b> INTRODUCTION (to amendment 1) <b>A1</b> .....	9
1 Scope .....	10
2 Normative references .....	10
3 Terms and definitions .....	11
4 General conditions for testing .....	13
4.1 Atmospheric conditions .....	13
4.2 Test equipment and materials .....	13
4.3 Voltage and frequency .....	13
4.4 Running-in of vacuum cleaner .....	13
4.5 Equipment of the vacuum cleaner .....	14
4.6 Operation of the vacuum cleaner .....	14
4.7 Conditioning prior to each tests .....	16
4.8 Mechanical operator .....	16
4.9 Number of samples.....	16
4.10 In-house reference cleaner system(s) .....	16
5 Dry vacuum cleaning tests .....	17
5.1 Dust removal from hard flat floors .....	17
5.2 Dust removal from hard floors with crevices .....	19
5.3 Dust removal from carpets .....	20
5.4 Dust removal along walls .....	23
5.5 Fibre removal from carpets and upholstery .....	24
5.6 Thread removal from carpets .....	28
5.7 Maximum usable volume of the dust receptacle .....	29
5.8 Air data .....	30
5.9 Performance with loaded dust receptacle .....	32
5.10 Total emission while vacuum cleaning .....	34
5.11 Filtration efficiency and dust re-emission of the vacuum cleaner .....	35
6 Miscellaneous tests .....	42
6.1 General .....	42
6.2 Motion resistance .....	42
6.3 Cleaning under furniture .....	42
6.4 Radius of operation .....	43
6.5 Impact resistance for detachable cleaning heads .....	44
6.6 Deformation of hose and connecting tubes .....	44
6.7 Bump test .....	45
6.8 Flexibility of the hose .....	47
6.9 Repeated bending of the hose .....	48
6.10 Life test .....	51
6.11 Mass .....	52
6.12 Weight in hand .....	52
6.13 Specific cleaning time .....	52
6.14 Dimensions .....	53
6.15 Noise level .....	53
6.16 Energy consumption .....	53
7 Test material and equipment .....	56
7.1 General .....	56

7.2	Material for measurements .....	56
7.3	Equipment for measurements .....	61
8	Instructions for use .....	77
Annex A (informative)	Information on materials .....	78
Annex B (informative)	Information at the point of sale .....	79
Annex C (normative)	Guidance specification on verified carpets .....	80
Bibliography .....		82
Figure 1	– Right-angled T .....	23
Figure 2	– Determination of cleaning area .....	24
Figure 3	– Stencil for distribution of fibres on test carpets .....	25
Figure 4	– Zig Zag stroke pattern .....	26
Figure 5	– Frame for test cushion .....	27
Figure 6	– Stencil for distribution of fibres on upholstery .....	27
Figure 7	– Arrangement of threads in the thread removal test .....	28
Figure 8	– Stroke length in measurements .....	29
Figure 9	– Air data curves .....	31
Figure 10	– Connecting tube opening .....	32
Figure 11	– Test dust for loading dust receptacle .....	33
Figure 12	– Insertion depth .....	43
Figure 13	– Position of test object and cross-section for measurement of deformation .....	45
Figure 14	– Profile of threshold .....	46
Figure 15	– Arrangements for bump test .....	46
Figure 16	– Preparation of hoses for testing flexibility .....	48
Figure Z.1	– Typical cylinder vacuum cleaner with primary hose .....	49
Figure Z.2	– Typical upright vacuum cleaner with secondary hose (contour front and back)....	49
Figure Z.3	– Typical upright vacuum cleaner with secondary hose used for cleaning curtains (left) and stairs (right) .....	50
Figure Z.4	– Example of a hose joining two or more components .....	51
Figure 17	– Equipment for repeated bending of hoses .....	50
Figure 18	– Test plate with crevice .....	62
Figure 19	– Carpet-beating machine .....	63
Figure 20	– Carpet hold-downs and guides .....	64
Figure 21	– Dust spreader and roller for embedding dust into carpets .....	64
Figure 22	– Alternative A equipment for air data measurements .....	65
Figure 23	– Measuring box for alternative A .....	66
Figure 24	– Alternative B equipment for air data measurements .....	68
Figure 25	– Test hood .....	72
Figure 26	– Aerosol channel with sampling probe .....	73
Figure 27	– Exhaust channel with sampling probe .....	73
Figure 28	– Drum for impact test .....	75
Figure 29	– Device for testing deformation of hoses and connecting tubes .....	76
Figure 30	– Mechanical operator for the measurement of dust removal from carpets and of motion resistance .....	77
Table 1	– Confidence limits of a Poisson distribution for 95 % - confidence range .....	41
Table 2	– Graduation of 8 size classes for particle sizes 0,3 µm – 10 µm .....	74



# INTERNATIONAL ELECTROTECHNICAL COMMISSION

---

## VACUUM CLEANERS FOR HOUSEHOLD USE –

### Part 1: Dry vacuum cleaners – Methods for measuring the performance

#### FOREWORD

- 1) The International Electrotechnical Commission (IEC) is a worldwide organization for standardization comprising all national electrotechnical committees (IEC National Committees). The object of IEC is to promote international co-operation on all questions concerning standardization in the electrical and electronic fields. To this end and in addition to other activities, IEC publishes International Standards, Technical Specifications, Technical Reports, Publicly Available Specifications (PAS) and Guides (hereafter referred to as "IEC Publication(s)"). Their preparation is entrusted to technical committees; any IEC National Committee interested in the subject dealt with may participate in this preparatory work. International, governmental and non-governmental organizations liaising with the IEC also participate in this preparation. IEC collaborates closely with the International Organization for Standardization (ISO) in accordance with conditions determined by agreement between the two organizations.
- 2) The formal decisions or agreements of IEC on technical matters express, as nearly as possible, an international consensus of opinion on the relevant subjects since each technical committee has representation from all interested IEC National Committees.
- 3) IEC Publications have the form of recommendations for international use and are accepted by IEC National Committees in that sense. While all reasonable efforts are made to ensure that the technical content of IEC Publications is accurate, IEC cannot be held responsible for the way in which they are used or for any misinterpretation by any end user.
- 4) In order to promote international uniformity, IEC National Committees undertake to apply IEC Publications transparently to the maximum extent possible in their national and regional publications. Any divergence between any IEC Publication and the corresponding national or regional publication shall be clearly indicated in the latter.
- 5) IEC itself does not provide any attestation of conformity. Independent certification bodies provide conformity assessment services and, in some areas, access to IEC marks of conformity. IEC is not responsible for any services carried out by independent certification bodies.
- 6) All users should ensure that they have the latest edition of this publication.
- 7) No liability shall attach to IEC or its directors, employees, servants or agents including individual experts and members of its technical committees and IEC National Committees for any personal injury, property damage or other damage of any nature whatsoever, whether direct or indirect, or for costs (including legal fees) and expenses arising out of the publication, use of, or reliance upon, this IEC Publication or any other IEC Publications.
- 8) Attention is drawn to the Normative references cited in this publication. Use of the referenced publications is indispensable for the correct application of this publication.
- 9) Attention is drawn to the possibility that some of the elements of this IEC Publication may be the subject of patent rights. IEC shall not be held responsible for identifying any or all such patent rights.

**This consolidated version of IEC 60312-1 consists of the first edition (2010) [documents 59F/195/FDIS and 59F/199/RVD] and its amendment 1 (2011) [documents 59F/206/CDV and 59F/207/RVC]. It bears the edition number 1.1.**

**The technical content is therefore identical to the base edition and its amendment and has been prepared for user convenience. A vertical line in the margin shows where the base publication has been modified by amendment 1. Additions and deletions are displayed in red, with deletions being struck through.**

International Standard IEC 60312-1 has been prepared by subcommittee 59F: Floor treatment appliances, of IEC technical committee 59: Performance of household and similar electrical appliances.

This publication has been drafted in accordance with the ISO/IEC Directives, Part 2.

A list of all the parts in the IEC 60312 series, under the general title *Vacuum cleaners for household use*, can be found on the IEC website.

The committee has decided that the contents of the base publication and its amendments will remain unchanged until the stability date indicated on the IEC web site under "<http://webstore.iec.ch>" in the data related to the specific publication. At this date, the publication will be

- reconfirmed,
- withdrawn,
- replaced by a revised edition, or
- amended.

A bilingual version of this publication may be issued at a later date.

**IMPORTANT – The “colour inside” logo on the cover page of this publication indicates that it contains colours which are considered to be useful for the correct understanding of its contents. Users should therefore print this publication using a colour printer.**

## **A1** INTRODUCTION (to amendment 1)

The following changes to IEC 60312-1 concern Subclauses 5.5 and 5.9 and the related specifications in Subclauses 7.2.2 and 7.2.6.

The reason for this is due to the tightening of the specification to the cotton linters used in the test dust. In order to reproduce the airflow restricting conditions expected during the development of this test it is necessary to use more test dust when Condition 3 is used as a stopping point. Further, it provides a specification for the cellulose dust.

In addition to this an updated specification of the cushion slip material is available. **A1**

## VACUUM CLEANERS FOR HOUSEHOLD USE –

### Part 1: Dry vacuum cleaners – Methods for measuring the performance

#### 1 Scope

This International Standard is applicable for measurements of the performance of dry vacuum cleaners for household use in or under conditions similar to those in households.

The purpose of this standard is to specify essential performance characteristics of dry vacuum cleaners being of interest to the users and to describe methods for measuring these characteristics.

NOTE 1 Due to influence of environmental conditions, variations in time, origin of test materials and proficiency of the operator, most of the described test methods will give more reliable results when applied for comparative testing of a number of appliances at the same time, in the same laboratory and by the same operator.

NOTE 2 This standard is not intended for battery-operated vacuum cleaners.

For safety requirements, reference is made to IEC 60335-1 and IEC 60335-2-2.

#### 2 Normative references

The following referenced documents are indispensable for the application of this document. For dated references, only the edition cited applies. For undated references, the latest edition of the referenced document (including any amendments) applies.

IEC 60688, *Electrical measuring transducers for converting a.c. electrical quantities to analogue or digital signals*

IEC 60704-1, *Household and similar electrical appliances – Test code for the determination of airborne acoustical noise – Part 1: General requirements*

IEC 60704-2-1, *Household and similar electrical appliances – Test code for the determination of airborne acoustical noise – Part 2-1: Particular requirements for vacuum cleaners*

ISO 554, *Standard atmospheres for conditioning and/or testing – Specifications*

ISO 679, *Methods of testing cements – Determination of strength*

ISO 1763, *Carpets – Determination of number of tufts and/or loops per unit length and per unit area*

ISO 1765, *Machine-made textile floor coverings – Determination of thickness*

ISO 1766, *Textile floor coverings – Determination of thickness of pile above the substrate*

ISO 2424, *Textile floor coverings – Vocabulary*

ISO 2439, *Flexible cellular polymeric materials – Determination of hardness (indentation technique)*

ISO 3386-1, *Polymeric materials, cellular flexible – Determination of stress-strain characteristics in compression – Part 1: Low-density materials*

ISO 5167-1, *Measurement of fluid flow by means of pressure differential devices inserted in circular cross-section conduits running full – Part 1: General principles and requirements*

ISO 8543, *Textile floor coverings – Methods for determination of mass*

ISO 12103-1, *Road vehicles – Test dust for filter evaluation – Part 1: Arizona test dust*

### 3 Terms and definitions

For the purpose of this document, the following definitions apply:

#### 3.1

##### **dry vacuum cleaner**

electrically operated appliance that removes dry material (e. g. dust, fibre, threads) from the surface to be cleaned by an airflow created by a vacuum developed within the unit, the removed material being separated in the appliance and the cleaned suction air being returned to the ambient

#### 3.2

##### **upright cleaner**

self-standing and floor-supported vacuum cleaner with the cleaning head forming an integral part of or permanently connected to the cleaner housing, the cleaning head normally being provided with an agitation device to assist dirt removal and the complete cleaner housing being moved over the surface to be cleaned by means of an attached handle

#### 3.3

##### **cleaning head**

plain nozzle or a brush attached to a connecting tube, or a power nozzle, separate or part of the cleaner housing, and that part of a vacuum cleaner which is applied to a surface to be cleaned

#### 3.4

##### **active nozzle**

cleaning head provided with a driven agitation device to assist dirt removal

NOTE The agitation device may be driven by an incorporated electric motor (motorized nozzle), an incorporated turbine powered by the air flow (air-turbine nozzle) or an incorporated friction or gear mechanism actuated by moving the cleaning head over the surface to be cleaned (mechanical nozzle)

#### 3.5

##### **passive nozzle**

cleaning head without any driven agitation devices

#### 3.6

##### **self-propelled cleaning head**

cleaning head provided with a propulsion mechanism

#### 3.7

##### **cleaning head width**

###### **B**

the external maximum width of the cleaning head in metres

#### 3.8

##### **active depth of the cleaning head**

distance from the front edge of the cleaning head to its rear edge or a line 10 mm behind the rear edge of the suction opening on the underside of the cleaning head, whichever is the shortest

**3.9**  
**cleaning cycle**

the sequence of five double strokes to be carried out at a specified stroke speed over the test area according to the appropriate stroke pattern

**3.10**  
**stroke pattern**

arrangement of the forward and return strokes on the surface to be cleaned

**3.11**  
**parallel pattern**

stroke pattern where the forward and the return strokes are congruent and are carried out in the direction of the carpet pile (direction of manufacture) unless otherwise specified

**3.12**  
**stroke speed**

speed of the cleaning head, moved as uniformly as possible, during a forward or a return stroke

**3.13**  
**stroke length**

distance between the two parallel lines defining the limits of a stroke pattern

**3.14**  
**double stroke**

one forward and one backward movement of the cleaning head performed in a parallel pattern

**3.15**  
**forward stroke**

forward movement of a stroke pattern

NOTE On test carpets, forward strokes are carried out in the direction of the carpet pile (direction of manufacturing).

**3.16**  
**return stroke**

backward movement of a stroke pattern

**3.24**  
**cylinder vacuum cleaner**

portable dry vacuum cleaner having a nozzle separated from the cleaner housing by a hose so that, in use, only the nozzle is guided over the surface area to be cleaned

Note 1 to entry: Cylinder vacuum cleaners are generally floor-supported.

Note 2 to entry: The cylinder vacuum cleaner may have detachable nozzles, attachments, and tubes for both floor and above the floor cleaning.

Note 3 to entry: The nozzle may employ a driven rotating brush to assist in cleaning.

**3.Z5**  
**water filter vacuum cleaner**

dry vacuum cleaner that uses water as the main filter medium, whereby the suction air is forced through the water entrapping the removed dry material as it passes through

**3.Z6**  
**water filter system**

removable water filter components which are in contact with the water 

## 4 General conditions for testing

### 4.1 Atmospheric conditions

Unless otherwise specified, the test procedures and measurements shall be carried out under the following conditions (in accordance with ISO 554):

#### *Standard atmosphere 23/50*

Temperature:	(23 ± 2) °C
Relative humidity:	(50 ± 5) %
Air pressure:	86 kPa to 106 kPa

NOTE Temperature and humidity conditions within the specified ranges are required for good repeatability and reproducibility. Care should be taken to avoid changes during a test.

For test procedures and measurements which may be carried out at other than standard atmospheric conditions, the ambient temperature shall be maintained at (23 ± 5) °C.

### 4.2 Test equipment and materials

To minimize the influence of electrostatic phenomena, measurements on carpets shall be carried out on a flat floor consisting of a smooth untreated pine plywood or equivalent panel, at least 15 mm thick and of a size appropriate for the test.

Equipment and materials for measurements (devices, test carpets, test dust etc.) to be used in a test shall, prior to the test, be kept hanging free or laying flat for at least 16 h at standard atmospheric conditions according to 4.1.

NOTE It is recommended that carpets that are already being used should be stored unbeaten at standard atmospheric conditions according to 4.1. When not in use they should be preferably hanging free, or may be lying flat, pile upwards and uncovered but not rolled.

### 4.3 Voltage and frequency

Unless otherwise stated, measurements shall be carried out at rated voltage with a tolerance of ±1 % and, if applicable, at rated frequency.

Vacuum cleaners designed for d.c. only shall be operated at d.c.. Vacuum cleaners designed for both a.c. and d.c. shall be operated at a.c.. Vacuum cleaners not marked with rated frequency shall be operated at either 50 Hz or 60 Hz, as is common in the country of use.

For vacuum cleaners with a rated voltage range, measurements shall be carried out at the mean value of the voltage range if the difference between the limits of the range does not exceed 10 % of the mean value. If the difference exceeds 10 % of the mean value, measurements shall be carried out both at the upper and lower limits of the voltage range.

If the rated voltage differs from the nominal system voltage of the country concerned, measurements carried out at rated voltage may give test results misleading for the consumer, and additional measurements may be required. If the test voltage differs from the rated voltage, this shall be reported.

### 4.4 Running-in of vacuum cleaner

Prior to the first test on a new vacuum cleaner it shall be kept running with unrestricted air flow for at least 2 h to ensure adequate running-in. For active nozzles, the agitation device shall be running but not in contact with the floor.

Prior to conducting any series of tests, the age, condition, and history of the product shall be recorded.

#### 4.5 Equipment of the vacuum cleaner

If the vacuum cleaner is designed to be used with disposable dust receptacles, it shall, prior to each measurement, be equipped with a new dust receptacle of the type recommended or supplied by the manufacturer of the vacuum cleaner.

If the vacuum cleaner is provided with a reusable dust receptacle (as the sole original dust receptacle or as an enclosure for disposable dust receptacles), the dust receptacle and any additional filters removable without the aid of tools shall, prior to each measurement, be cleaned according to manufacturer's instructions until its weight is within 1 % or 2 g of its original weight whichever is the lower.

Some reusable receptacles consist of a rigid container and an integral filter. In this case the container and the filter are considered to be the receptacle and should be treated as if they were a single component.

Vacuum cleaners equipped with separation devices, being part of the appliance, used to separate the dust from the airflow and/or having additional filters to be changed or cleaned by the user, without the use of tools, the weight of such specific devices shall be taken into account for dust removal ability.

Vacuum cleaners with disposable or reusable dust receptacles may have secondary filtration stage devices which do not collect meaningful dust in removal ability tests but which do impact on filtration and life tests. Replacement and/or maintenance of such devices shall be in accordance with relevant sections and carried out according to manufacturer's instructions.

#### 4.6 Operation of the vacuum cleaner

##### Ⓒ 4.6.1 General

The tube grip of cleaners with suction hose or the handle of other cleaners shall be held as for normal operation at a height of  $(800 \pm 50)$  mm above the test floor.

During measurements where the agitation device of an active nozzle is not used as in normal operation, the agitation device shall be running but not in contact with any surface.

The following wording regarding declaration and compliance shall also apply to EN 60704-2-1, and EN 60335-2-2. For declaration and compliance purposes, related tests for a given cleaning task shall be conducted with the same dry vacuum cleaner setting configurations such as cleaning head and cleaning head setting.

NOTE 1: Related tests are all tests related to a given cleaning task. They include tests relevant to the Energy Labelling and Ecodesign requirements for cordless dry vacuum cleaners.

NOTE 2: Related tests are:

- tests measuring the dust removal from carpet, the energy consumption for cleaning a carpet and the noise level on carpet;
- tests measuring the dust removal from hard floor with crevices and the energy consumption for cleaning a hard floor with crevices and the noise level on hard floors (for noise measurement regarding Energy Label / Ecodesign refer to Regulations 665/2013 and 666/2013).

The dry vacuum cleaner setting configurations, such as cleaning head and cleaning head setting, shall be used and adjusted in accordance with the manufacturer's instructions for the surface to be cleaned (e.g. carpet or hard floor) for the test to be carried out. Any separate electrical specific vacuum motor settings shall be set for maximum continuous airflow and, unless the manufacturer's instructions states otherwise, any manually operated air by-pass opening for reduction of the suction power shall be closed.

In the absence of unambiguous instructions within the user manual the product shall be tested with settings that are in accordance with any explicitly clear text, symbol or pictogram that is identifiable on the product. Ⓒ



- Ⓒ If, after following the above order of checks, the tester believes the device under test to be in a configuration that is ambiguous, or that multiple configurations are possible with no way to clearly determine which is the most suitable for a given task, then the manufacturer shall be contacted for additional guidance.

Complete details of the settings used for each cleaning task are to be recorded in the test documentation.

Where a manufacturer publishes/declares values for the performance of its product, e.g. in the Technical Documentation, it shall provide accurate and unambiguous details of the settings that were used during the test procedure.

NOTE 3: Performance in other settings/combinations may differ from the results in the declaration settings, however the standard does not address those results.

#### **4.6.2 Operation of water filter vacuum cleaner, additional requirements**

##### **4.6.2.1 Determining the water loss**

Prior to the preconditioning the water loss of the water filter vacuum cleaner shall be determined.

The water filter vacuum cleaner has to run according to manufacturer's instructions for a period of 10 min with the suction nozzle lifted 20 mm off the floor at standard temperature and standard relative humidity. Before and after this running time of 10 min the weight of the water filter system shall be measured with an accuracy of at least 0,1 g. This test shall be repeated three times and an average of these 3 tests shall be noted.

The ambient condition has a big influence on the water loss. Temperature and air humidity will have impact on the results. Therefore the temperature and air humidity should be controlled carefully.

##### **4.6.2.2 Filter conditions**

###### **4.6.2.2.1 For dust removal from hard flat floor (see 5.1) and from carpet (see 5.3)**

If the value measured according to 4.6.1.1 is lower than 0,1 g/min the water filter vacuum cleaner shall be used according to manufacturer's instructions for the dust removal from hard flat floors and carpet.

NOTE: The mass of water which is lost during the measuring time is low and has no relevant influence on the test result.

Water Filter vacuum cleaners should not be moved to minimize the loss of water.

If the value measured according to 4.6.1.1 is equal or higher than 0,1 g/min and the water filter vacuum cleaner is equipped with a dust collection system which doesn't use water, this collecting system will be included to determine the dust removal from hard flat floors according to 5.1.6 and dust removal from carpets according to 5.3.

The air data according to 5.8 shall be measured with the water filter system used according to the manufacturer's instructions. Then, the vacuum cleaner shall be equipped with the dust collecting system without water and the maximum airflow shall be adjusted to  $\pm 3\%$  of the measured values with the water filter system.

In all other cases the dust removal from hard flat floors and from carpet shall be performed using the dust collecting box (see 7.3.Z2 Dust collecting box) as a pre filter system. The vacuum cleaner shall be used according to manufacturer's instructions.

The dust collecting box is equipped with a filter bag. The filter bag from the reference vacuum cleaner system could be used. For measuring dust pick up the filter bag shall be handled in the same way as it is handled in the reference vacuum cleaner system Ⓒ

#### **Ⓒ 4.6.2.2.2 For all other tests with a water filter vacuum cleaner**

The vacuum cleaner and its attachments shall be used and adjusted in accordance with the manufacturer's instructions for normal operation for the test to be carried out. Ⓒ

#### **4.7 Conditioning prior to each tests**

If the vacuum cleaner is unused and de-energized for more than 1 h, then the vacuum cleaner and attachments to be used shall be kept running for at least 10 min under the provisions given in 4.4 to allow them to stabilise.

#### **4.8 Mechanical operator**

In order to achieve reliable results, certain measurements require the cleaning head to be moved at uniform speed over the test area and without exerting an additional force pressing the cleaning head against the test surface.

It is recommended to simulate the handling of the vacuum cleaner by using a mechanical operator such as described in 7.3.12. The tube grip of cleaners with suction hose or the handle of other cleaners shall then be attached to the linear drive so that its centre pivots at a height of  $(800 \pm 50)$  mm above the test surface. For nozzles without pivoting connectors, it shall be ensured that the bottom of the cleaning head be made parallel with the test surface by adjusting the handle height within the tolerances. If this is not possible, the length of a telescopic tube may be adjusted. Any adjustment shall be reported.

The linear drive may be motorized or operated by hand. The method of operation shall be reported.

#### **4.9 Number of samples**

All measurements of performance shall be carried out on the same sample(s) of the vacuum cleaner with its attachments, if any.

NOTE For increased confidence in the test results, it is recommended that a minimum of three samples of a vacuum cleaner should be tested.

Tests carried out to simulate stresses a vacuum cleaner may be exposed to during normal use, possibly causing impairment of the cleaner's performance, may require additional samples of replaceable parts. Such tests shall be carried out at the end of the test programme.

#### **4.10 In-house reference cleaner system(s)**

NOTE 1 The reference cleaner referred to in this standard is a product designated within a laboratory for internal comparison and should not be used for inter-laboratory comparisons

Test carpets used in a laboratory for the determination of dust removal ability will, over time, change from their original conditions, for instance due to wearing or gradual filling with dust. It is therefore required that in-house reference cleaner system(s) be used to regularly check the carpet conditions as a verification of the test results obtained and being recorded.

NOTE 2 Due to the fact that pick-up ability may differ between carpets used for active or passive nozzles, the result from tests between active and passive nozzles may not be compared.

Test carpets designated for testing of passive nozzles shall only be cleaned with a passive nozzle on the face. Test carpets designated for testing active nozzles shall only be cleaned with an active nozzle on the face.

## 5 Dry vacuum cleaning tests

### 5.1 Dust removal from hard flat floors<sup>1</sup>

#### 5.1.1 Test equipment

A floor test plate in accordance with 7.3.1 shall be used.

#### 5.1.2 Test area and stroke length

The length of the test area is  $(700 \pm 5)$  mm. The width of the test area is equal to the cleaning head width (see 3.7).

A length of at least 200 mm shall be added before the beginning of the test area and at least 300 mm after the end of the test area in order to allow acceleration and deceleration of the cleaning head.

Thus, the stroke length is at least 1200 mm for the given test length of 700 mm. The centreline of the front edge of the cleaning head is aligned to the centre line of the beginning of the acceleration area at the commencement of the stroke allowing the distance of 200 mm to be used for acceleration. The cleaning head shall reach the end of the stroke when the rear edge of the active depth of the cleaning head is at least 200 mm past the end of the test area, thus allowing a suitable distance for deceleration. The reverse stroke is carried out in the same manner until the front edge of the cleaning head is once again lined up with the beginning of the acceleration length in front of the test area.

The active depth of the cleaning head shall move at uniform stroke speed  $0,50 \text{ m/s} \pm 0,02 \text{ m/s}$  and in a straight line over the test area.

For optimum control of the double stroke movement it is recommended that an electromechanical operator (see 4.8) be used.

Two hold-downs in accordance with 7.3.4 serve the purpose of acting as guides to keep the cleaning head in a straight line as it is moved over the test area and to ensure an undisturbed flow.

Vacuum cleaners equipped with a self drive device shall be operated at the prescribed stroke speed of  $0,5 \text{ m/s} \pm 0,02 \text{ m/s}$  if possible. Otherwise, the stroke speed will be determined by the vacuum cleaner.

#### 5.1.3 Removal of remaining dust

The hard surface shall be dry cleaned so that no dust remains prior to any subsequent test.

#### 5.1.4 Distribution of test dust

Test dust, Type 1 in accordance with 7.2.2.1, shall be distributed with a mean coverage of  $50 \text{ g/m}^2$  per square metre as uniformly as possible over the test area.

The amount of test dust to be used is calculated from the formula  $B \times 0,7 \text{ m} \times 50 \text{ g/m}^2$ , where  $B$  is the cleaning head width in meters and the length of the test area is 0,7 m.

---

<sup>1</sup> This test is under review and may be substituted by a debris pick-up test from hard floor.

### 5.1.5 Preconditioning of dust receptacle

In order to minimize the effects of humidity, the dust receptacle shall be preconditioned as follows.

The vacuum cleaner under test is equipped with a clean dust receptacle and allowed to run with an unimpeded air flow with the nozzle clear of the surface for 2 min or until input power has stabilised.

After the preconditioning, the dust receptacle and any filters removable without tools are removed from the cleaner to be weighed. The weight shall be noted and the items are replaced.

NOTE 1 Since the cleaner air flow can have an effect on the weight of the dust receptacle during the 2 min preconditioning, caution should be taken so that the weight of the dust receptacle has stabilised before weighing.

NOTE 2 For water filter vacuum cleaners consider 4.6.1.

### 5.1.6 Determination of dust removal ability

Three separate measurements, each comprising one double stroke, shall be carried out. After the double stroke, the cleaning head shall be lifted at least 50 mm clear of the surface before the vacuum cleaner is switched off. The dust receptacle shall not be removed before the motor has completely stopped.

Once the cleaner has completely stopped, the receptacle is carefully removed and reweighed. Due to effects of possible static charge build-up during the time the vacuum cleaner is picking up dust, it is necessary to ensure that the receptacle has completely stabilised prior to recording the weight.

The dust removal ability is calculated as the ratio of the weight increase of the dust receptacle during the double stroke to the weight of the test dust distributed on the test area. The mean value for 3 measurements is calculated as follows:

$$K_B(3) = (K_{B1} + K_{B2} + K_{B3})/3$$

where  $K_{Bi} = 100 \times (m_{DRf} - m_{DRe})/m_D$

and

$K_B(i)$  is the mean dust removal for  $i$  measurements in per cent;

$K_{Bi}$  is the dust removal for measurement  $i$  in per cent;

$m_D$  is the weight of the dust distributed on the test area in grams;

$m_{DRe}(i)$  is the weight of the preconditioned dust receptacle in grams;

$m_{DRf}(i)$  is the weight of the dust receptacle after cleaning in grams.

When the mean value is lower than 90 %: should the range of measurements be greater than 3 percentage units, two additional measurements are carried out and the mean value of all the measurements should be given as the result.

When the mean value is equal or higher than 90 %: should the range of the measurements be greater than  $0,3 \times (100 \% - \text{mean value})$ , two additional measurements are carried out and the mean value of all the measurements should be given as the result.

In both cases, consideration should be given to the control of repeatability within the laboratory and the design or manufacture of the cleaner or cleaning head in order to ascertain whether any factors not previously observed may affect the repeatability adversely.

NOTE For water filter vacuum cleaners consider 4.6.1.

## 5.2 Dust removal from hard floors with crevices

### 5.2.1 Test equipment

The surface, in accordance with 7.3.2, consists of a wooden test plate incorporating a removable aluminium insert with a crevice, the angle between the crevice and the direction of strokes being 45°.

The test plate may be fitted to the test rig according to 7.3.12 or, if being used for testing by hand, is placed upon the floor.

Two hold-downs in accordance with 7.3.4 serve the purpose of acting as guides to keep the cleaning head in a straight line as it is moved over the test area. The guides should have a distance of 10 mm from the surface to ensure an undisturbed flow.

### 5.2.2 Distribution of test dust

The insert is weighed and its crevice thereafter filled with mineral dust, in accordance with 7.2.2.1. After levelling the surface of the dust with a rubber scraper, the insert is again weighed and carefully replaced in the test plate, avoiding shaking.

### 5.2.3 Determination of dust removal ability

During a measurement, the cleaning head is passed over the crevice by performing double strokes in a parallel pattern at a stroke speed of  $(0,50 \pm 0,02)$  m/s, keeping the cleaning head to the centre of the test plate. The quantity of dust removed from the crevice after five double strokes is determined as the difference in weight of the insert before and after cleanings, both values being recorded.

The dust removal ability, in per cent, is calculated according to the following formula as the ratio of the quantity of dust removed to the quantity of dust in that part of the crevice which is determined by the cleaning head width (see 3.2.5) and accounting for the oblique angle of 45°:

$$k_{cr} = \frac{m_L - m_r}{m_L} \frac{L}{B} \cos 45^\circ \times 100$$

where

$k_{cr}$  is the dust removal ability, in per cent;

$m_L$  is the dust quantity in the crevice before cleaning, in grams;

$m_r$  is the dust quantity remaining in the crevice after cleaning, in grams;

$L$  is the length of the crevice, in metres;

$B$  is the cleaning head width, in metres.

Two separate measurements shall be carried out to establish a mean value of the dust removal ability for five double strokes,  $k_{cr5}$ , to be reported separately.

### 5.3 Dust removal from carpets

#### 5.3.1 Test carpet

A test carpet, in accordance with 7.2.1, shall be used; the type of carpet selected shall be recorded. It shall have been prepared in accordance with 7.2.1.4. Due to the significant influence of humidity on this test, the carpet shall be left in the test environment at standard atmospheric conditions for at least 16 h before the test is due to commence.

The preferred carpet for comparative testing purposes is the Wilton Carpet (see 7.2.1.3.2). If additional carpet(s) are desired for testing, the carpet(s) shall be selected from those specified in Subclause 7.2.1.3.

During measurements the carpet is kept in position on the test floor by the use of carpet hold-downs (see 7.3.4). The carpet is to be fixed on the test floor at the end where the forward stroke starts. A force of  $60_{-0}^{+10}$  N shall be applied at the other end of the test carpet to define the tension on the carpet during testing.

☐ NOTE There are known issues with the reproducibility of this test. An extensive round robin test is underway to define the uncertainties within the procedure for future versions of the standard. Changes may be necessary to the way it is recommended the test is performed and results are corrected. ☐

#### 5.3.2 Test area and stroke length

The direction of the stroke on the test area shall be in the direction of the carpet pile. The length of the test area is  $700 \text{ mm} \pm 5 \text{ mm}$ . The width of the test area is equal to the cleaning head width (see 3.7).

A length of at least 200 mm shall be added before the beginning of the test area and at least 300 mm added after the test area in order to allow for acceleration and deceleration of the cleaning head.

Thus, the stroke length is at least 1200 mm for the given test length of 700 mm. The centreline of the front edge of the cleaning head is aligned to the centre line of the beginning of the acceleration area at the commencement of the stroke, allowing the distance of 200 mm to be used for acceleration. The cleaning head shall reach the end of the stroke when the rear edge of the active depth of the cleaning head is at least 200 mm past the end of the test area, thus allowing a suitable distance for deceleration. The reverse stroke is carried out in the same manner until the front edge of the cleaning head is once again lined up with the beginning of the acceleration length in front of the test area.

The active depth of the cleaning head shall move at uniform stroke speed  $0,50 \text{ m/s} \pm 0,02 \text{ m/s}$  and in a straight line over the test area.

Vacuum cleaners equipped with a self drive device shall be operated at the prescribed stroke speed of  $0,5 \text{ m/s} \pm 0,02 \text{ m/s}$  if possible. Otherwise, the stroke speed will be determined by the vacuum cleaner.

NOTE 1 For optimum control of the double stroke movement it is recommended that an mechanical operator (see 4.8) be used.

NOTE 2 The two carpet hold-downs serve the purpose of holding the test carpet in position during measurement and of acting as guides to keep the cleaning head in a straight line as it is moved over the test area. The guides should have a distance of 10 mm from the carpet surface to ensure an undisturbed flow.

### 5.3.3 Conditioning of test carpet

#### 5.3.3.1 General

Prior to each measurement, the test carpet shall be cleaned to remove remaining dust and preconditioned as described below.

#### 5.3.3.2 Removal of remaining dust

For cleaning of the test carpet, it is recommended to use a suitable carpet-beating machine such as described in 7.3.3.

If a carpet-beating machine is not used, the carpet shall be placed upside down on a rigid mesh support and be beaten by hand or with an active nozzle. After the beating, one cleaning cycle with a vacuum cleaner having good dust removal ability should be carried out to remove remaining dust. Test carpets designated for testing of passive nozzles shall only be cleaned with a passive nozzle on the face (although an active nozzle may be used on the back).

#### 5.3.3.3 Verification and preconditioning

After cleaning of the test carpet, the vacuum cleaner under test shall be equipped with a clean dust receptacle (see 4.5) and be used to verify that the carpet has been cleaned to the point where no dust pick-up is discernible. This point is considered to be reached if the amount of dust removed from the carpet during five cleaning cycles is less than 0,2 g. If the amount is greater than 0,2 g, this step is repeated until the requirement is achieved.

NOTE 1 Even if the equipment for removing remaining dust from the carpet is known to be sufficiently reliable to leave the carpet in acceptable condition, it is still important to carry out this procedure of preconditioning to ensure that the effect of humidity on the carpet is minimized.

NOTE 2 To prevent a gradual filling of the carpet with dust, the weight of the test carpet should be maintained as close as possible to that of the initially clean carpet.

☐ NOTE 3 For water filter vacuum cleaners consider 4.6.1. ☐

#### 5.3.4 Distribution of test dust

Test dust, in accordance with 7.2.2.2, shall be distributed with a mean coverage of  $125 \text{ g/m}^2 \pm 0,1 \text{ g/m}^2$  as uniformly as possible over the test area.

The amount of test dust to be used is calculated from the formula  $B \times 0,7 \text{ m} \times 125 \text{ g/m}^2$ , where  $B$  is the cleaning head width in metres and the length of the test area is 0,7 m. For uniform distribution of the test dust over the test area, it is recommended that a dust spreader as described in 7.3.5 be used. The adjustment of the device is checked by visual examination of the test dust on the carpet.

#### 5.3.5 Embedding of dust into carpet

The dust shall be embedded into the test carpet by carrying out 10 double strokes over the carpet parallel with the direction of the pile with a roller, in accordance with 7.3.6.1. The speed of the roller over the test area shall be a uniform  $0,5 \text{ m/s} \pm 0,02 \text{ m/s}$  with the forward stroke being in the direction of the pile. It is important to ensure that the test area is completely and evenly rolled. The carpet is then left for a period of 10 min to recover from rolling.

#### 5.3.6 Preconditioning of dust receptacle

In order to minimize the effects of humidity, the dust receptacle shall be preconditioned as follows.

Since the cleaner air flow may cause an electrostatic build-up and can have an effect on the scales weighing the dust receptacle during the 2 min preconditioning, caution shall be taken that the weight of the dust receptacle has stabilised before recording the weight. Grounding the receptacle may help the electrostatic build-up to discharge and thus allow a more accurate weight to be taken.

The vacuum cleaner under test is equipped with a clean or reconditioned dust receptacle and/or filters shall be run with an unimpeded air flow for 2 min, for instance during the 10 min period the carpet recovers from rolling.

After the preconditioning, all dust receptacle(s) and removable filters are removed from the cleaner to be weighed. The weights are noted and the items are replaced.

### 5.3.7 Determination of dust removal ability

Prior to each cleaning cycle, the sequence of preparations outlined in 5.3.4 to 5.3.6 shall be performed in total.

Three separate cleaning cycles, each comprising five double strokes, shall be carried out. After the fifth double stroke, the cleaning head shall be lifted at least 50 mm clear of the carpet. At the end of each cleaning cycle all hoses and tubes of the vacuum cleaner shall be agitated before the vacuum cleaner is switched off. The dust receptacle shall not be removed before the motor has completely stopped.

Once the cleaner has completely stopped, the receptacle(s) and removable filters are carefully removed and reweighed. Due to effects of possible static charge build up during the time the vacuum cleaner is picking up dust, it is necessary to ensure that the receptacle has completely stabilised prior to recording the weight.

The dust removal ability is calculated as the ratio of the weight increase of the dust receptacle and removable filters as defined in 4.5 during the 5 double strokes to the weight of the test dust distributed on the test area. The mean value for 3 cleaning cycles is calculated as follows:

$$K_T(3) = (K_{T1} + K_{T2} + K_{T3})/3$$

where

$$K_{Ti} = 100 \times (m_{DRf} - m_{DRe})/m_D$$

and

$K_T(i)$  is the mean dust removal for  $i$  cleaning cycles in per cent;

$K_{Ti}$  is the dust removal for a single cleaning cycle  $i$  in per cent;

$m_D$  is the weight of the dust distributed on the test area in grams;

$m_{DRe}(i)$  is the total weight of the preconditioned dust receptacle(s) and removable filter(s) in grams;

$m_{DRf}(i)$  is the total weight of the dust receptacle(s) and removable filter(s) after 5 double strokes in grams.

If the range of values for  $K_{Ti}$  is greater than three percentage units, two additional cleaning cycles shall be performed. In this case, the mean dust removal ability shall be calculated as follows:

$$K_T(5) = (K_{T1} + K_{T2} + K_{T3} + K_{T4} + K_{T5})/5$$

NOTE 1 As an example, the values for  $K_{Ti}$  of 45 %, 47 % and 49 % give a range of 4 percentage units. Thus, two additional cleaning cycles shall be carried out.



NOTE 2 If a problem with the repeatability continues and a downward trend is observed with the results, refer to Subclause 4.5 and consider the equipment being weighed during the test.

NOTE 3 If the results of the first cleaning cycle differ by more than 3% from the following two tests, it is permissible to repeat that test before applying the 2 additional tests rules.

For the dust removal ability the mean value, the value range and the number of cleaning cycles shall be recorded as well as the type of carpet used.

NOTE 4 For water filter vacuum cleaners consider 4.6.1.

## 5.4 Dust removal along walls

### 5.4.1 Test equipment and materials

A right-angled T in accordance with Figure 1, formed by two pieces of wood or other suitable material, shall be used for this test. It shall be sufficiently heavy to remain in position during the measurements or be kept in position by the use of clamps or weights.

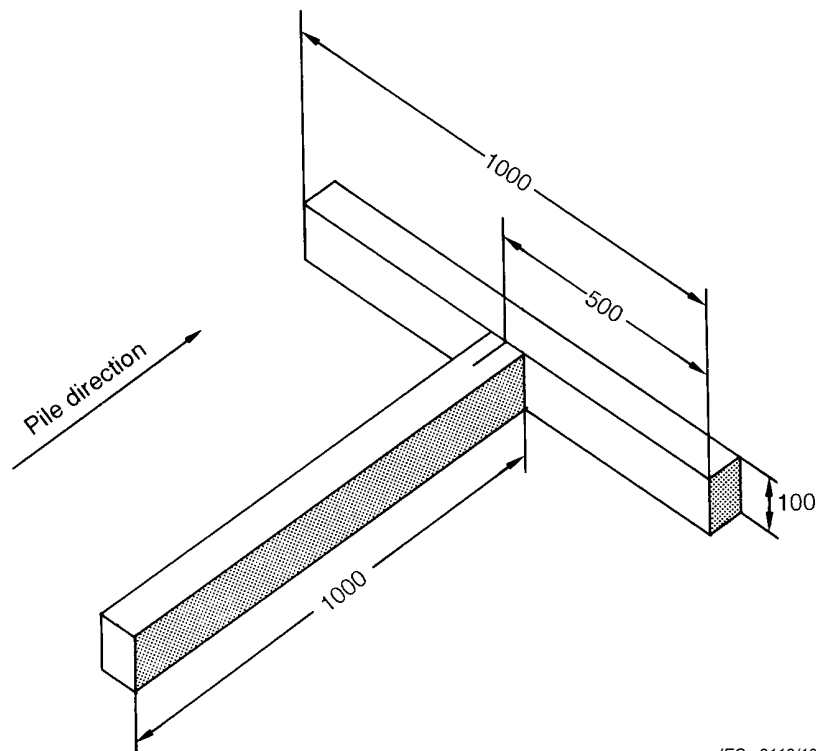

*Dimensions in millimetres*

**Figure 1 – Right-angled T**

For measurements on carpets, a Wilton test carpet in accordance with 7.2.1.3.2 shall be used. For measurements on hard flat floors, a floor test plate in accordance with 7.3.1 shall be used.

### 5.4.2 Distribution of test dust

A sufficient amount of mineral dust, in accordance with 7.2.2.1, shall be distributed over an area of the test surface corresponding to the extremities of the T to ensure good visible coverage.

### 5.4.3 Determination of dust removal ability along walls

The T is placed over the dust-covered area of the test surface and, if necessary, secured by clamps or weights. When placed on a test carpet, the leg of the T shall be located parallel with the direction of the carpet pile (see Figure 1).

One double stroke is carried out at a speed of  $(0,25 \pm 0,05)$  m/s with the cleaning head guided along one side of the leg of the T, pausing for 2 s to 3 s at the end of the forward stroke to define the limit of the front edge cleaning.

The width of the visible uncleaned area is measured at three equally spaced points along the leg and along the cross-bar of the T to establish, to the nearest millimetre, two mean values representing the dust removal ability along walls, at the side and in the front of the cleaning head, both values being reported. See Figure 2 for guidance.

If the cleaning head is not symmetrically constructed, the test is repeated along the other side of the leg of the T.

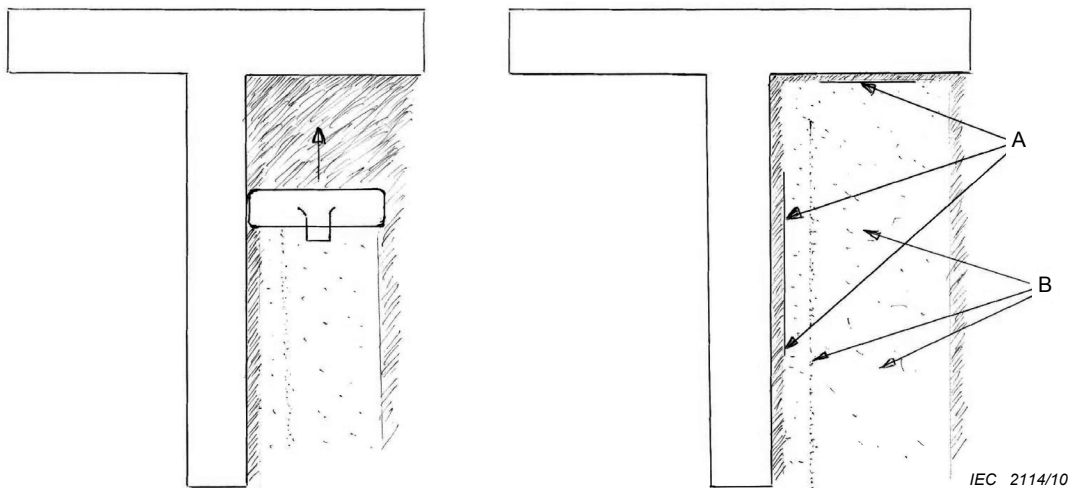

Shows cleaning head being moved forward through applied dust until the cross of the "T" is reached.

After cleaning head is removed measurements are made to where the dust is most undisturbed "A". Random remaining dust particles or where possibly a belt guard is situated, are ignored "B".

**Figure 2 – Determination of cleaning area**

## 5.5 Fibre removal from carpets and upholstery

### 5.5.1 General

The vacuum cleaner shall be equipped with the cleaning head designed for the surface to be cleaned.

### 5.5.2 Fibre removal from carpets

#### 5.5.2.1 Test carpet

A Wilton test carpet, in accordance with 7.2.1.3.2, shall be used. Test carpets designated for fibre removal tests shall not be used for other tests.

Prior to each measurement, the surface of the test carpet shall be cleaned thoroughly until the carpet surface is visually free of remaining fibres.

### 5.5.2.2 Distribution of fibres

For the distribution of fibres, a stencil, in accordance with Figure 3, shall be used. The stencil shall be 3 mm in thickness, have 95 holes, 30 mm in diameter, and be free from burrs. The stencil shall be placed on the test carpet with its 1000 mm long sides parallel to the warp. The stencil shall be placed on the test carpet with its 1000 mm long sides parallel to the warp.

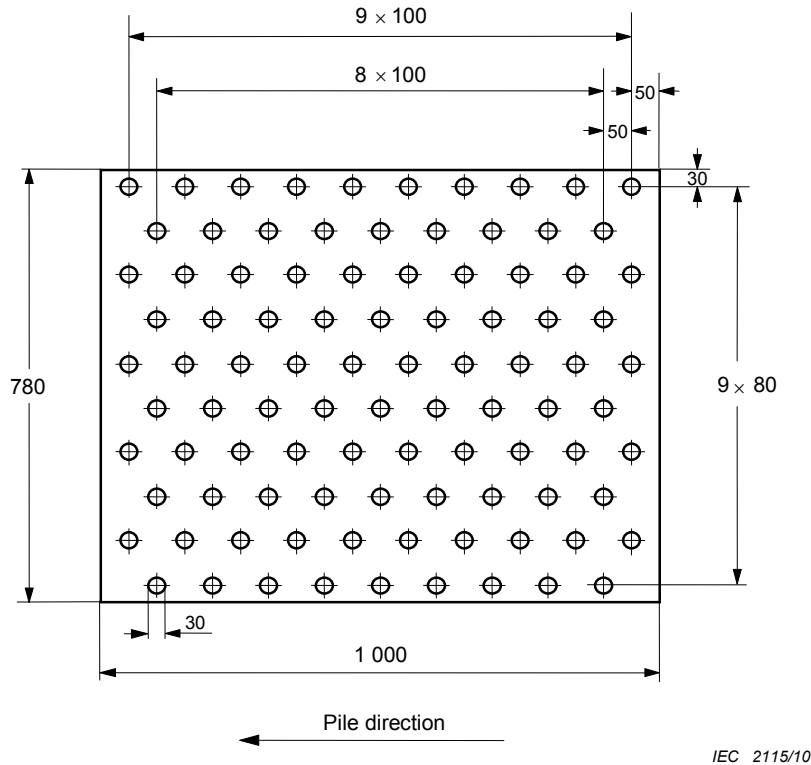

*Dimensions in millimetres*

**Figure 3 – Stencil for distribution of fibres on test carpets**

150 mg ± 5 mg of fibre material, in accordance with 7.2.3, shall be plucked by hand into 95 approximately equal portions, which are then pressed lightly by the thumb, without rubbing or twisting, in the centres of the holes of the stencil.

After removing the stencil, the fibres are embedded into the carpet by carrying out five double strokes with a roller, in accordance with 7.3.6.2. The direction of the strokes shall be at right angles to the warp of the carpet, and the stroke speed shall be about 0,5 m/s. If the roller is less than 1 m in length, the rolling schedule is repeated until the entire test area has been covered.

### 5.5.2.3 Determination of fibre removal ability from carpets

Prior to each measurement, fibres sticking to the cleaning head shall be removed.

The cleaning head is passed once over the fibre-covered area in a zigzag pattern as shown in Figure 4 with the forward strokes at right angles to the warp. If cleaning head width is not an exact multiple of the test area width, make sure the final stroke ensures that the test area has been completely covered.

Remaining fibres may then be removed by carrying out strokes in the direction of the pile not following a specific pattern. The stroke speed shall be 0,5 m/s ± 0,05 m/s and care shall be taken that the cleaning head is in full contact with the test carpet during the cleaning.

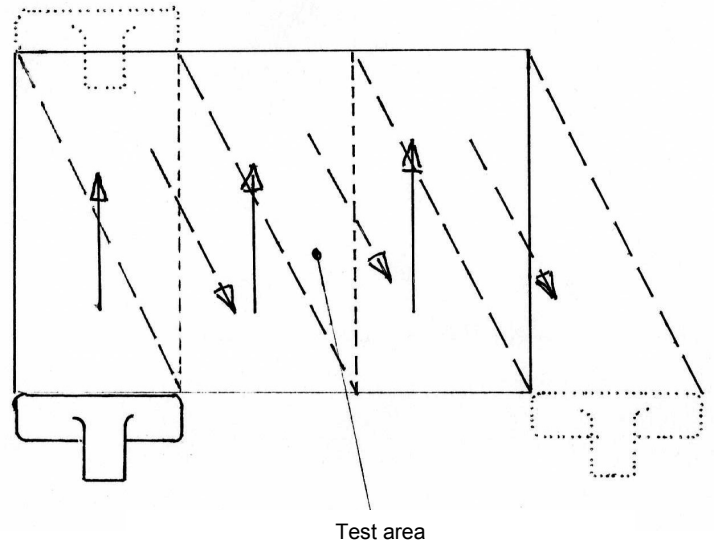

**Figure 4 – Zig Zag stroke pattern**

The time to remove all fibres (judged visually by the operator from a standing position) shall be recorded. If the cleaning time exceeds 180 s, the cleaning is discontinued.

Three separate measurements shall be carried out to establish a mean value of the fibre removal ability. The time to remove fibres sticking to the cleaning head shall not be taken into account.

### **A1 5.5.3 Fibre removal from upholstery A1**

#### **5.5.3.1 Test cushion**

A test cushion, in accordance with 7.2.6, shall be used. Prior to each measurement, the surface of the test cushion shall be cleaned thoroughly until the cushion surface is visually free of remaining fibres.

The test cushion shall be placed in a wooden frame, in accordance with Figure 5, to give a working height of about 480 mm above the floor. The frame shall be provided with an adjustable stop strip, which shall rest on the test cushion and be immovable during the measurements.

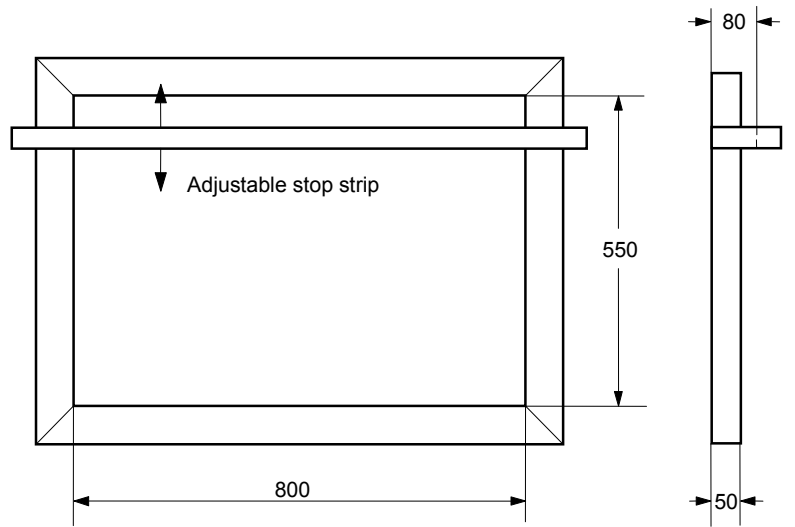

IEC 2117/10

Dimensions in millimetres

**Figure 5 – Frame for test cushion**

**5.5.3.2 Distribution of fibres**

For the distribution of fibres, a stencil, in accordance with Figure 6, shall be used. The stencil shall be 2 mm in thickness, have 23 holes, 30 mm in diameter, and be free from burrs.

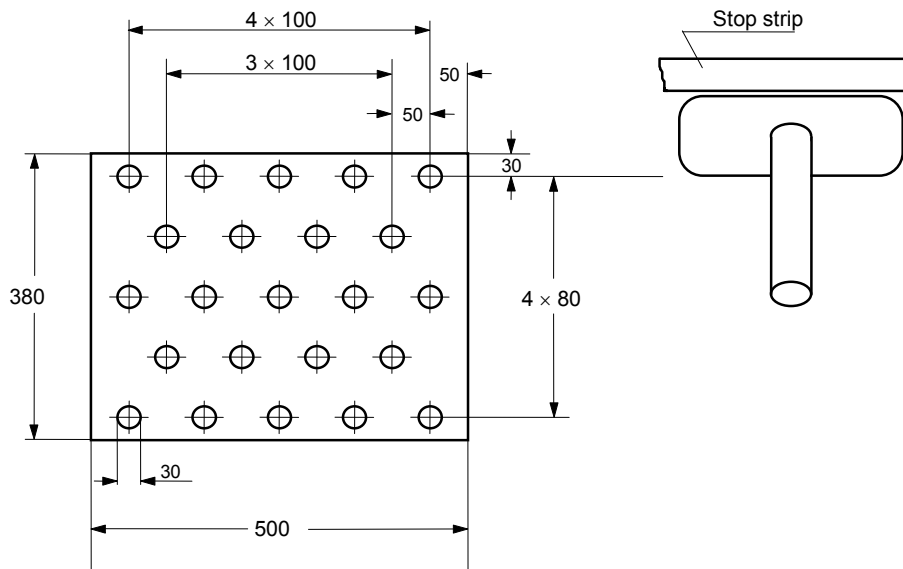

IEC 2118/10

Dimensions millimetres

**Figure 6 – Stencil for distribution of fibres on upholstery**

The stencil shall be placed on the test cushion with its 500 mm long sides parallel to the 800 mm long sides of the cushion in such a way that the distance between the stop strip and the centre line of the nearest row of holes is equal to the active depth of the cleaning head.

45 mg ± 1 mg of fibre material, in accordance with 7.2.3, shall be plucked by hand into 23 approximately equal portions, which are then pressed lightly by the thumb, without rubbing or twisting, in the centres of the holes of the stencil.

### 5.5.3.3 Determination of fibre removal ability from upholstery

Prior to each measurement, fibres sticking to the cleaning head shall be removed.

After removing the stencil, the cleaning head is passed once over the fibre-covered area in a zigzag pattern with the forward strokes at right angles to the stop strip. Remaining fibres may then be removed by carrying out strokes parallel to the stop strip not following a specific pattern. Fibres, which have been pushed against the stop strip, may be removed by strokes along the strip. The stroke speed shall be 0,5 m/s ± 0,05 m/s and care should be taken that the cleaning head is in full contact with the test cushion during the cleaning.

The time to remove all fibres (judged visually by the operator from a standing position) shall be recorded. If the cleaning time exceeds 300 s the cleaning is discontinued.

Three separate measurements shall be carried out to establish a mean value of the fibre removal ability. The time to remove fibres sticking to the cleaning head shall not be taken into account.

## 5.6 Thread removal from carpets

### 5.6.1 Test carpet

A Wilton test carpet in accordance with 7.2.1.3.2 shall be used.

### 5.6.2 Distribution of threads

Forty pieces of threads, in accordance with 7.2.4, shall be arranged on the test carpet in four rows parallel with the pile direction according to the pattern shown in Figure 7. Each row shall have a length of 0,7 m and the distance between rows is adapted to the cleaning head width.

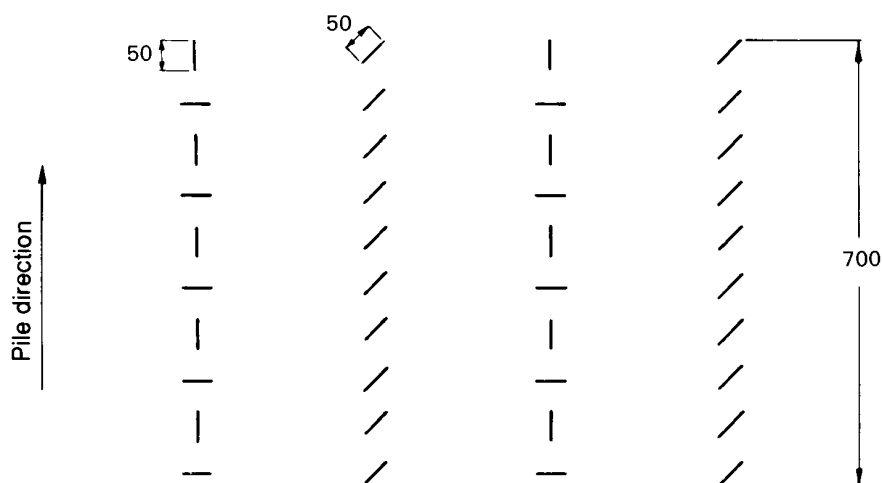

IEC 2119/10

Dimensions in millimetres

**Figure 7 – Arrangement of threads in the thread removal test**

The threads are embedded into the carpet by carrying out five double strokes with a roller, in accordance with 7.3.6.2, over each row and at a stroke speed of 0,50 m/s ± 0,05 m/s.

### 5.6.3 Determination of thread removal ability

The cleaning head shall be adjusted for carpet cleaning and, if applicable, utilize such special arrangements that are provided to assist thread removal.

Prior to each measurement, threads sticking to the cleaning head shall be removed.

During a measurement, each row of threads is cleaned with one double stroke at a stroke speed of  $0,50 \text{ m/s} \pm 0,05 \text{ m/s}$ , unless the cleaning head is self-propelled, the stroke length being in accordance with 5.1.2 (see Figure 8). The ratio of the number of threads removed from the carpet to the number of distributed threads is calculated and recorded.

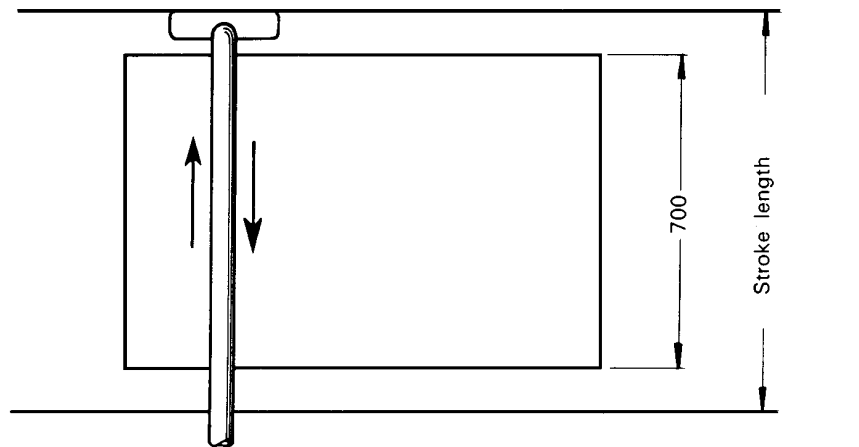

IEC 2120/10

*Dimensions in millimetres*

**Figure 8 – Stroke length in measurements**

Three separate measurements shall be carried out to establish a mean value of the thread removal ability, in per cent.

NOTE Threads sticking to the cleaning head are considered to be removed from the carpet. It is recommended that a suitable observation be made in the test report.

## 5.7 Maximum usable volume of the dust receptacle

The maximum usable volume of the dust receptacle is determined as follows.

### 5.7.1 Conditions for measurement

The vacuum cleaner shall be equipped with a clean dust receptacle (see 4.6) and placed in its normal position of operation. Upright vacuum cleaners shall be tested in their vertical position. If a paper bag and similar material as fleece is used,  $10 \text{ mg/cm}^2$  of the bag filter area of fine powdered chalk shall be introduced slowly into the cleaner to inflate the bag completely.

NOTE 1 Usable alternative to chalk powder is under consideration.

NOTE 2 Some bag materials such as fleece may require larger quantities of chalk dust. It is permissible to use alternative methods of inflation in this case as long as they do not artificially inflate the bag more than would be the case with normal use.

Moulding granules, in accordance with 7.2.5, shall be used for the test.

NOTE 3 Standard atmospheric condition according to 4.1 not required.

NOTE 4 The granules may be reused provided they are relieved of excessive chalk and have not been damaged.

### 5.7.2 Introduction of moulding granules

The moulding granules are gradually introduced into the cleaner in 1 l increments to a visible maximum level mark, if present, or until the cleaner will not accept any more.

☐ For water filter vacuum cleaner the visible maximum level mark has to be checked with vacuum cleaner off. ☐

NOTE For upright cleaners without provision for optional use of a hose, the granules are fed through a nozzle adaptor with the handle of the cleaner in normal position of use. For other cleaners, the granules are fed through the hose provided.

### 5.7.3 Determination of maximum usable volume of dust receptacle

Measure the mass of 1 l of granules 10 times to determine its density prior to feeding into the vacuum cleaner. Weigh the dust receptacle before feeding and then again after feeding. The difference divided by the density determines the volume.

☐ For water filter vacuum cleaner the water loss during the feeding time shall be taken into consideration. The ON duration during the feeding time has to be measured and multiplied with the water loss measured according to 4.6.1.1. This lost weight shall be added to the calculated usable volume.

NOTE 1 For water filter vacuum cleaners take into consideration that the density of the moulding granules could change due to the contact with water. ☐

Three measurements shall be carried out to establish a mean value, which represents the maximum usable volume of the dust receptacle being tested.

## 5.8 Air data

### 5.8.1 Purpose

The purpose of the determination of air data is to compare the specified parameters between vacuum cleaners and also to determine certain parameter values for other tests. The following parameters, referred to standard air density  $\rho = 1,20 \text{ kg/ m}^3$  (at 20 °C, 101,3 kPa and 50 % relative humidity), are considered:

$q$  is the air flow, in litres per second (l/s);

$h$  is the vacuum, in kilopascals;

$P_1$  is the input power, in watts;

$P_2$  is the suction power, in watts;

$\eta$  is the efficiency, in per cent.

NOTE 1 Standard atmospheric condition according to 4.1 not required.

NOTE 2 Measured air data should be corrected to standard air density (see 7.3.7.5).

### 5.8.2 Conditions for measurement

Vacuum cleaners, which in normal operation are equipped with hose, and/or connecting tube, shall have such components attached but without nozzle or brush and shall be connected to the measuring chamber at the end of the tube with the hose fully collapsed and if the connecting tube is telescopic it shall be fully extended.

Upright cleaners without a hose connection to the cleaner head shall be adapted to the measuring chamber with their suction opening sealed to the measuring chamber. For upright cleaners with option to be operated with or without a hose, air data shall be obtained for both options and be reported separately.

The vacuum cleaner shall be prepared and operated as stated in 4.3 to 4.7.



### 5.8.3 Test equipment

Either of the alternative test equipment described in 7.3.7 may be used. For both alternatives a plenum chamber of  $(500 \times 500 \times 500)$  mm<sup>3</sup> or  $(460 \times 460 \times 250)$  mm<sup>3</sup> shall be used.

NOTE If the airflow is greater than 40 l/s, the use of the larger plenum chamber is recommended for both alternative A and B.

### 5.8.4 Determination of air data

Air flow, vacuum and input power are determined for a number of throttlings sufficient for plotting curves of vacuum and input power against the air flow (see Figure 9).

Prior to the sequence of measurements, the vacuum cleaner shall be operated unthrottled in accordance with 4.7 to establish a reference value of the exhaust air temperature for further measuring points.

For each measuring point, the air flow, vacuum and input power are recorded 1 min after the throttling. The cleaner is then again operated unthrottled to attain the reference conditions, which is checked by measuring the exhaust air temperature. This procedure is continued until all the entire curves have been plotted with the measuring point for maximum vacuum being the last one.

For each measuring point, the suction power  $P_2$  is obtained as the product of the air flow  $q$  and the vacuum  $h$ . The efficiency  $\eta$  is calculated as the ratio of corresponding values of the suction power and input power. Curves of suction power and of efficiency are also plotted against the air flow (see Figure 9).

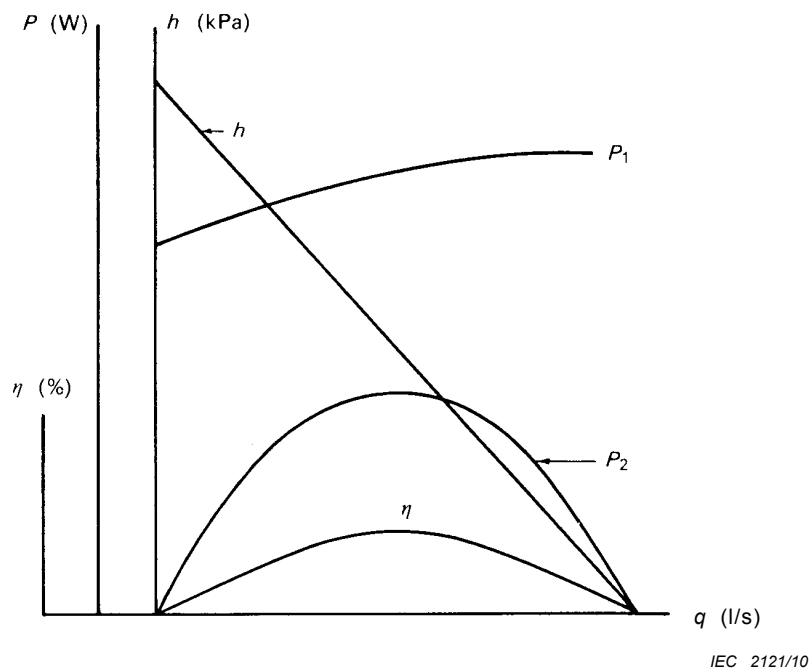

- $h$  vacuum in the measuring box, in kilopascals
- $q$  air flow, in litre per seconds (l/s)
- $P_1$  input power, in watts
- $P_2$  suction power, in watts
- $\eta$  efficiency, in percent

Figure 9 – Air data curves

The maximum value of the suction power  $P_{2max}$  and the theoretic maximum value of the airflow  $q_{max}$  shall be estimated according to the procedure given in 7.3.7.6.

## 5.9 Performance with loaded dust receptacle

### 5.9.1 Purpose

NOTE This method is used to determine the effects, if any, of dust loading during a single filling of the receptacle. It is not a long term sustained performance test, which is being developed separately for a future edition, and is not intended to represent a specific point of filling of the receptacle. It may be considered “full” if the stopping point reached is determined by the operation of the receptacle full indicator, otherwise the point reached should be considered to be somewhere between empty and full and performance tests undertaken at this point will give an indication as to how well the vacuum cleaner can perform as the receptacle fills and/or the filters fill with dust.

The purpose of this procedure is to provide the means to measure the performance of a vacuum cleaner with a loaded dust receptacle. The test vacuum cleaner shall be evaluated in both the unloaded and simulated loaded condition using Subclauses 5.1 to 5.6.

The test is not intended to measure the capacity of receptacle or filter.

### 5.9.2 Determination of suction pressure change with loaded dust receptacle

#### 5.9.2.1 Test conditions

The vacuum cleaner shall be operated under the same conditions as for the determination of performance characteristics. The change of the suction pressure in the adaptor when vacuuming specified test material shall be measured.

- For this purpose the hose, for canister cleaners and uprights with hose, is connected to the plenum chamber, as described in 5.8.3, via an adaptor, as shown in Figure 10. The adaptor, which shall not alter the original airflow of the vacuum cleaner, by being restrictive or by creating turbulence, has an opening for a feed tube for test dust with a diameter  $14 \text{ mm} \pm 2 \text{ mm}$  at a distance of at least 150 mm from the pressure tapping. This opening shall be capable of being sealed closed during the measurements of suction.

**A1** NOTE It is permissible to use the pressure tapping on the plenum chamber to measure pressure. **A1**

The openings in the adaptor shall not impair the air flow.

The feed tube shall be connected to a flexible tube and a probe with which the test material is picked up evenly as described in 5.9.2.3. The feed set up shall not impair the properties of the test material according to 7.2.2.3.

- The plenum chamber shall be fitted with a 30 mm orifice plate.

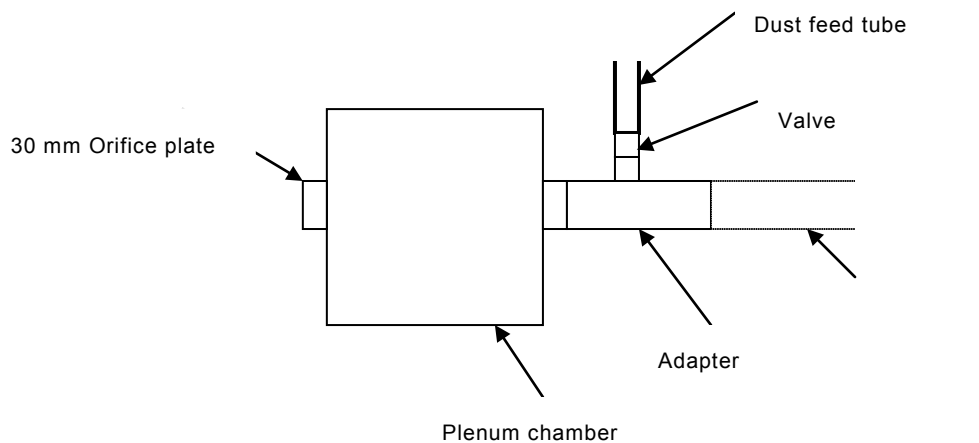
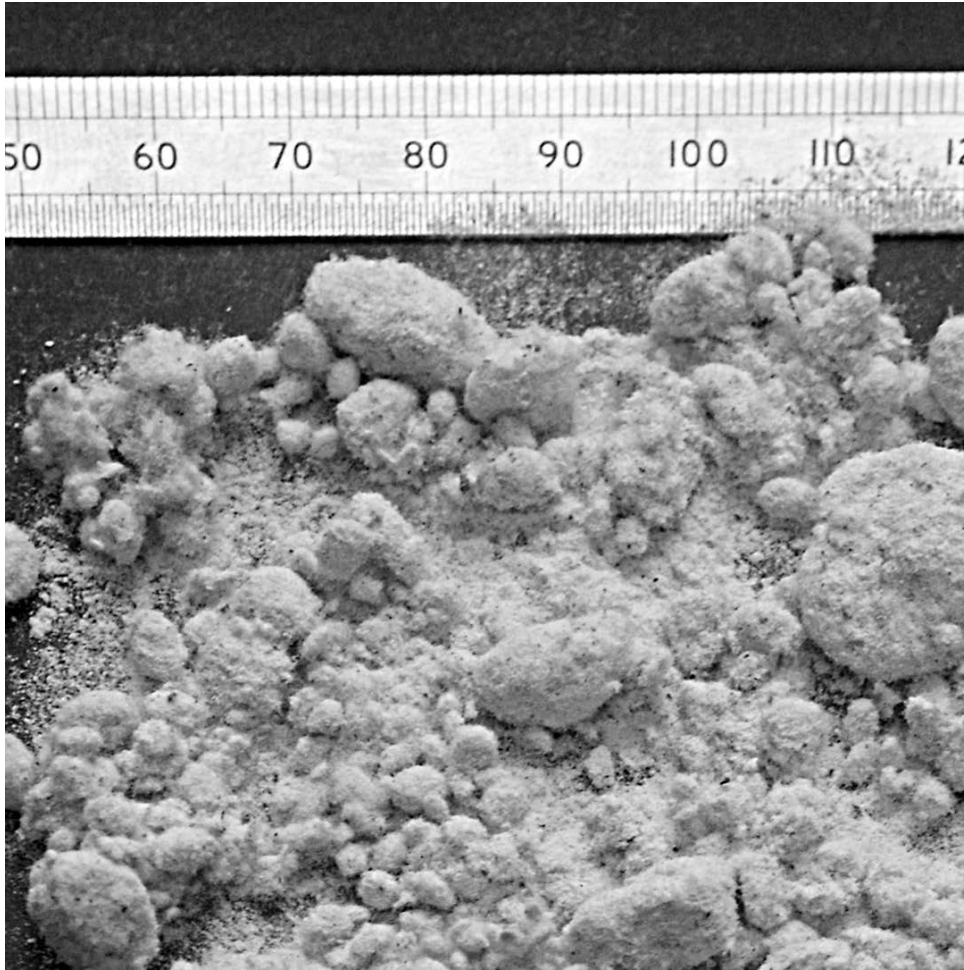

Figure 10 – Connecting tube opening

For an upright vacuum cleaner where it is not possible to fit a hose, it is permissible to mount the vacuum cleaner on to the plenum chamber as shown in Figure 24. The pressure may be measured using the pressure tapping on the plenum chamber. A suitable position in the ducting from the nozzle to the dirt receptacle shall be found to fit a dust feed tube as described for the adaptor above. In this case the mounting method shall be reported.

### 5.9.2.2 Test dust

Test dust, see Figure 11, in accordance with 7.2.2.3, shall be used for loading the dust receptacle.



IEC 2123/10

Figure 11 – Test dust for loading dust receptacle

### 5.9.2.3 Test method

The vacuum cleaner shall be prepared in accordance with 5.9.2.1.

With the feed tube closed, the vacuum cleaner is run for at least 10 min. Subsequently, the initial vacuum,  $h_0$ , shall be determined.

The test material shall be fed in 50 g batches which are representative for the overall mixture over a time period of 60 s each.

For vacuum cleaners with self cleaning filters or dust compressor functions, the cleaner shall be operated in accordance with the manufacturer's instructions after each batch of dust.

After each batch the feed tube shall be closed. The pressure measurement,  $h_f$ , shall be determined no less than 2 min or when the pressure reading has stabilised, after the feed tube has been closed. Then, the feed tube is reopened and the feeding of the next batch continued.

If the volume of receptacle is less than 1 l or the maximum airflow of the vacuum cleaner is less than 15 l/s, then the feeding rate is reduced to 25 g/min.

The injection of test dust is terminated when one of the following conditions is first reached:

Condition 1: An indicator on the vacuum cleaner signals that the dust receptacle should be emptied or replaced. Where a product has a full bin indicator on the front of its bin, the full bin indication as described in the manufacturer's instruction shall determine the stopping point.

Condition 2: The observed value of the vacuum  $h_f$  has dropped to  $40 \begin{smallmatrix} +0,5 \\ -0 \end{smallmatrix} \%$  of  $h_0$ .

Condition 3: The amount of injected test dust has reached a total of  $\boxed{A_1}$  100  $\boxed{A_1}$  g/l of the maximum usable volume of the dust receptacle (see 5.7).

The values for  $h_0$ ,  $h_f$  in relation to the total amount of test material taken up and the condition for termination shall be recorded.

NOTE 1 If  $h_f < 40\%$  of  $h_0$ , the restriction will be created to provide a suction value equal to 40 % of the initial reading.

$\boxed{A_1}$  Text deleted  $\boxed{A_1}$

### 5.9.3 Throttling to simulate loaded dust receptacle

The vacuum cleaner shall be equipped with a clean dust receptacle and filters in accordance with 4.5.

It shall be operated according to 5.9.2 with the feed tube closed.

The volume flow of the vacuum cleaner whilst connected to the plenum chamber shall be suitably throttled until the value  $h_f$  of 5.9.2 is obtained.

The throttling is undertaken by inserting a suitable device between dust receptacle and motor/fan chamber. However, it is essential that the throttling shall not alter the characteristics of the effects of loading with the dust and shall not restrict the manner in which the dirt is transported from the surface being cleaned to the receptacle.

### 5.9.4 Determination of performance with loaded dust receptacle

Any of the tests described in 5.1 to 5.6 shall be performed with the throttling described in 5.9.3.

The throttled vacuum cleaner may be submitted to air data measurement in order to complement data obtained in the cleaning performance tests.

## 5.10 Total emission while vacuum cleaning

*Under consideration*<sup>3</sup>

---

<sup>3</sup> The ASTM F2608 test method is being considered

## 5.11 Filtration efficiency and dust re-emission of the vacuum cleaner

### 5.11.1 Purpose

The aim of this test is to determine the ability of a vacuum cleaner to retain dust, depending on particle size, from the intake aerosol containing a predefined concentration of test dust.

This test is not suitable for determining permeability of filters or filter materials.

### 5.11.2 Test conditions

NOTE A relative humidity of 45 % RH to 55 % RH is recommended for control of static.

Measuring equipment required for the test is specified in 7.3.8.

In preparation of the test, the vacuum cleaner should be equipped with a new or thoroughly cleaned dust receptacle and new filters according to specifications. It is to be set to operate at maximum airflow.

The vacuum cleaner is placed centrally under the test hood in its normal operation condition.

Dust will be fed

- to vacuum cleaners with a suction hose, through this hose,
- to vacuum cleaners without a suction hose (for instance Uprights) through a suitable auxiliary hose which is connected and sealed tightly to the suction nozzle by use of a nozzle adaptor.

For water filter vacuum cleaner distilled water shall be used for measuring the filtration efficiency. The amount of water shall be taken from the manufacturer's instructions. In order not to measure water droplets a diffusion dryer shall be added to the inlet of the particle counter.

### 5.11.3 Determining the test dust quantity

For the entire duration of dust, according to 7.2.2.5 being fed, the dust concentration  $c$  shall be  $0,1 \text{ g/m}^3$  in the intake aerosol channel. Therefore, the maximum airflow  $q$  for the vacuum cleaner with the given filter equipment shall be determined.

The quantity  $m$  of dust to be fed for duration  $t_{\text{DUST}}$  is calculated consequently as

$$m = c \times t_{\text{DUST}} \times q$$

### 5.11.4 void

### 5.11.5 void

### 5.11.6 Test procedure

#### 5.11.6.1 General

A test run can be conducted either by using two particle counters which read intake and exhaust values simultaneously or by using a single particle counter which is switched for reading intake and exhaust values, respectively.

Particle registration is by particle analysing system (see 7.3.8.5) which can be operated with a suitable aerosol dilution system to adapt count rate capacity and the particle concentration of aerosol intake and of exhaust channel, respectively. The results of any single trial shall be recorded as follows:

- counter events / class; i.e. the number of events recorded by the particle counter, separately for each range of particle size as well as for aerosol intake channel and exhaust channel;
- sample air volumes,  $VA_{\text{Ex}}$  (exhaust) and  $VA_{\text{In}}$  (intake); i.e. the volumes of the aerosol samples analysed by the particle counter combined in the course of the trial;
- applicable dilution factors  $k_{\text{VA}}$  (intake or exhaust) of the particle analysis system; i.e. the ratio between the volume of the air sample extracted from the channel and the sample air volume analysed by the particle counter.  $\text{C}$

Ⓒ The following test procedure for a single trial may be repeated with several dry vacuum cleaners of identical type. Then the final result of the test run has to be averaged arithmetically.

NOTE 1 Proper dilution ratio needs to be verified. Prove not over-concentrated by serial dilution and prove not over-diluted on the exhaust by lessening the dilution serially, see 7.3.8.5.

NOTE 2 There are known issues with the particle transport within this test. Measures are under development to ensure and verify a proper particle transport. Changes may be necessary to the measuring equipment or to the way the test is performed.

#### 5.11.6.2 Single particle counter procedure

A single trial proceeds as follows:

- the dry vacuum cleaner is operated without dust being fed until acceptable and stable conditions are achieved (minimum 10 min, maximum 30 min). This method stability is  $\pm 10\%$  for particle counts over 100 for 30 s or less than 100 particle counts per 30 s over at least 10 min.
- conditioning: dust is fed for 10 min while the particle concentration in the aerosol intake channel is monitored (quantity of test dust according to 5.11.3),
- sampling: feeding of dust is continued for approximately 10 min during which 5 test cycles are carried out, each consisting of:
  - particle registration from aerosol intake channel for 30 s (intake measurement),
  - flushing of particle analysing system with the applicable sample stream for  $\geq 10$  s,
  - particle registration from exhaust channel for 30 s (exhaust measurement),
  - flushing of particle analysing system with the applicable sample stream for  $\geq 10$  s.

#### 5.11.6.3 Dual particle counter procedure

If two particle counters are used, they need to be verified to match in calibration and count rate. Their particle counts have to be within 10 % in each range of particle size for particle counts over 100 for 30 s.

A single trial proceeds as follows:

- the dry vacuum cleaner is operated without dust being fed until acceptable and stable conditions are achieved (minimum 10 min, maximum 30 min). This method stability is  $\pm 10\%$  for particle counts over 100 for 30 s or less than 100 particle counts per 30 s over at least 10 min.
- conditioning: dust is fed for 10 min while the particle concentration in the aerosol intake channel is monitored (quantity of test dust according to 5.11.3),
- sampling: feeding of dust is continued for 150 s during which 5 test cycles are carried out, each consisting of continuous particle registration from both aerosol intake channel (intake measurement) and exhaust channel (exhaust measurement) for 30 s.

### 5.11.7 Evaluation

#### 5.11.7.1 General

Based on the particle counts obtained in the 5 measurement cycles, for aerosol intake channel and exhaust channel, the evaluation can be done either for

- fractional filtration efficiency (for each class of particle size) or
- filtration efficiency for the entire range of particle size (i.e. from 0,3  $\mu\text{m}$  to 10  $\mu\text{m}$ ).

Filtration efficiency E for the entire range of particle size is 1 minus the ratio of number of particles exhaust and number of particles intake.

Dust re-emission R for the respective range of particle size is defined as 1 minus E which is the ratio of number of particles exhaust and number of particles intake.

The basic formulae are:

$$E = 1 - R$$

$$R = 1 - E \quad \text{Ⓒ}$$

Ⓒ The detailed determination of E and R for a range of particle size including consideration of the 95 % confidence level is shown below.

**5.11.7.2 Evaluation of fractional filtration efficiency**

Based on the particle counts obtained in the 5 measurement cycles, for aerosol intake channel and exhaust channel, the fractional filtration efficiency is derived for each particle class.

The individual measurements are considered to be samples of a full distribution, and a statistical analysis is performed accordingly.

Given the particle counts  $z(k,l)_U$  of the aerosol intake channel for particle class  $k$  obtained from each individual measurement cycle  $l$ , the corresponding lower limits of the 95 % - confidence range,  $Z(k)_U$ , are obtained as follows:

- summation of particle counts obtained for particle class  $k$  in 5 individual measurements intake

$$Z(k)_U = \sum_{l=1}^5 z(k,l)_U$$

where

$k$  is the index of particle class;

$l$  is the running index of individual measurement cycles;

$(k,l)_U$  is the particle count intake in class  $k$  from individual measurement cycle  $l$ ;

$Z(k)_U$  is the particle sum intake in class  $k$  from all measurement cycles;

- determination of the 95 % lower - confidence limits  $Z(k)_{U,0.95}$  for the particle sums  $Z(k)_U$ :

If  $Z(k)_U > 50$  : 
$$\underline{Z(k)}_{U,0.95} = Z(k)_U - 1.96 \times (Z(k)_U)^{\frac{1}{2}}$$

If  $Z(k)_U \leq 50$  : 
$$\underline{Z(k)}_{U,0.95}$$
 from Table 1.

Given the particle counts  $z(k,l)_D$  of the exhaust channel for particle class  $k$  obtained from each individual measurement cycle  $l$ , the corresponding upper limits of the 95 % - confidence range,  $\overline{Z(k)}_{D,0.95}$  are similarly derived by

- summation of particle counts obtained for particle class  $l$  in 5 individual measurements exhaust:

$$Z(k)_D = \sum_{l=1}^5 z(k,l)_D$$

where

$k$  is the index of particle class;

$l$  is the running index of individual measurement cycles;

$z(k,l)_D$  is the particle count exhaust in class  $k$  from individual measurement cycle  $l$ ;

$Z(k)_D$  is the particle sum exhaust in class  $k$  from all 5 measurement cycles;

- determination of corresponding upper limits of the 95 % - confidence range  $\overline{Z(k)}_{D,0.95}$  from particle sums  $Z(k)_D$ : Ⓒ



$$\begin{aligned} \text{C)} \text{ If } Z(k)_D > 50: & \quad \overline{Z(k)}_{D,0,95} = Z(k)_D + 1,96 \times (Z(k)_D)^{\frac{1}{2}} \\ \text{If } Z(k)_D \leq 50: & \quad \overline{Z(k)}_{D,0,95} \text{ from Table 1.} \end{aligned}$$

From the statistical limits calculated above, the lower limit of the 95 % - confidence range of the fractional filtration efficiency,  $\underline{E(k)}_{-0,95}$ , is obtained for each particle class  $k$  :

$$\underline{E(k)}_{-0,95} = 1 - \left( \frac{\overline{Z(k)}_{D,0,95} \times k_{VA\_D} \times \left( \frac{VA_U}{VA_D} \right)}{\overline{Z(k)}_{U,0,95} \times k_{VA\_U}} \right)$$

where

- $k$  is the index of particle class;
- $E(k)_{0,95}$  is the lower limit of confidence for filtration efficiency of particle class  $k$ ;
- $k_{VA\_D}$  is the exhaust dilution factor of particle analysis system;
- $k_{VA\_U}$  is the intake dilution factor of particle analysis system;
- $VA_D$  is the exhaust sample air volume analysed;
- $VA_U$  is the intake sample air volume analysed;
- $Z(k)_{D,0,95}$  is the upper limit of confidence for partial sum class  $k$  from exhaust measurements;
- $Z(k)_{U,0,95}$  is the lower limit of confidence for particle sum class  $k$  from intake measurements.

This evaluation shall be carried out in every test.

### 5.11.7.3 Evaluation of filtration efficiency and dust re-emission for the entire range of particle size

The individual measurements are considered to be samples of a full distribution, and a statistical analysis is performed accordingly.

Given the particle counts  $z(k,l)_U$  of the aerosol intake channel for particle class  $k$  obtained from each individual measurement cycle  $l$ , the corresponding lower limits of the 95 % - confidence range,  $\underline{Z(k)}_U$ , are obtained as follows:

- summation of particle counts obtained for the entire range of particle size between 0,3  $\mu\text{m}$  and 10  $\mu\text{m}$  in 5 individual measurements intake

$$\underline{Z(k)}_U = \sum_{l=1}^5 z(k,l)_U$$

where

- $k$  is the index of particle class;
- $l$  is the running index of individual measurement cycles;
- $(k,l)_U$  is the particle count intake in class  $k$  from individual measurement cycle  $l$ ; C



Ⓒ  $Z_{0,3-10U}(l)$  is the intake sum of particles between 0,3 µm and 10 µm from individual measurement cycle  $l$ .

- summation of particle counts for 5 measurement cycles

$$Z_{0,3-10U} = \sum_{l=1}^5 Z_{0,3-10U}(l)$$

Where

$l$  is the running index of individual measurement cycles;

$k_{0,3}$  is the particle class with the lower limit of 0,3 µm;

$k_{10}$  is the particle class with the upper limit of 10 µm;

$Z_{0,3-10U}$  is the intake sum of particles between 0,3 µm and 10 µm.

- determination of the 95 % lower - confidence limits  $Z_{0,3-10U,0,95}$  for the particle sums

$Z_{0,3-10U}$ :

If  $Z_{0,3-10U} > 50$ :  $Z_{0,3-10U,0,95} = Z_{0,3-10U} - 1,96 \times (Z_{0,3-10U})^{\frac{1}{2}}$

If  $Z_{0,3-10U} \leq 50$ :  $Z_{0,3-10U,0,95}$  from Table 1.

Given the particle counts  $z(k,l)_D$  of the exhaust channel for particle class  $k$  obtained from each individual measurement cycle  $l$ , the corresponding upper limits of the 95 % - confidence range,  $Z(k)_{D,0,95}$  are similarly derived by

- summation of particle counts obtained for the entire range of particle size between 0,3 µm and 10 µm in 5 individual measurements exhaust:

$$Z_{0,3-10D}(l) = \sum_{k=k_{0,3}}^{k_{10}} Z(k,l)_D$$

where

$k$  is the index of particle class;

$l$  is the running index of individual measurement cycles;

$z(k,l)_D$  is the particle count exhaust in class  $k$  from individual measurement cycle  $l$ ;

$Z_{0,3-10D}(l)$  is the exhaust sum of particles between 0,3 µm and 10 µm from individual measurement cycle  $l$ ;

- summation of particle counts for 5 measurement cycles:

$$Z_{0,3-10D} = \sum_{l=1}^5 Z_{0,3-10D}(l)$$

Where

$l$  is the running index of individual measurement cycles;

$k_{0,3}$  is the class with the lower limit of 0,3 µm

$k_{10}$  is the particle class with the upper limit of 10 µm

$Z(k)_D$  is the particle sum exhaust in class  $k$  from all 5 measurement cycles;

$Z_{0,3-10D}$  is the exhaust sum of particles between 0,3 µm and 10 µm Ⓒ

Ⓒ – determination of corresponding upper limits of the 95 % - confidence range  $\overline{Z}_{0,3-10_{D,0,95}}$  from particle sums  $Z_{0,3-10D}$ :

$$\text{If } Z_{0,3-10D} > 50: \quad \overline{Z}_{0,3-10_{D,0,95}} = Z_{0,3-10D} + 1,96 \times (Z_{0,3-10D})^{\frac{1}{2}}$$

$$\text{If } Z_{0,3-10D} \leq 50: \quad \overline{Z}_{0,3-10_{D,0,95}} \text{ from Table 1.}$$

From the statistical limits calculated above, the lower limit of the 95 % - confidence range of the filtration efficiency,  $\underline{E}_{0,3-10,0,95}$ , is obtained :

$$\underline{E}_{0,3-10,0,95} = 1 - \left( \frac{\overline{Z}_{0,3-10_{D,0,95}} \times k_{VA\_D} \times \left( \frac{VA_U}{VA_D} \right)}{Z_{0,3-10_{U,0,95}} \times k_{VA\_U}} \right)$$

$$\overline{R}_{0,3-10,0,95} = 1 - \underline{E}_{0,3-10,0,95}$$

where

$\underline{E}_{0,3-10,0,95}$  is the lower limit of confidence for filtration efficiency of particles between 0,3 µm and 10 µm;

$\overline{R}_{0,3-10,0,95}$  is the upper limit of confidence for dust re-emission of particles between 0,3 µm and 10 µm;

$k_{VA\_D}$  is the exhaust dilution factor of particle analysis system;

$k_{VA\_U}$  is the intake dilution factor of particle analysis system;

$VA_D$  is the exhaust sample air volume analysed;

$VA_U$  is the intake sample air volume analysed;

$\overline{Z}_{0,3-10_{D,0,95}}$  is the upper limit of confidence for particle sum of particles between 0,3 µm and 10 µm from exhaust measurements;

$Z_{0,3-10_{U,0,95}}$  is the lower limit of confidence for particle sum of particles between 0,3 µm and 10 µm from intake measurements.

This evaluation shall be carried out in every test. Ⓒ

**Table 1 – Confidence limits of a Poisson distribution for 95 % - confidence range**

<b>z</b>	$\underline{z}_{0,95}$	$\bar{z}_{0,95}$	<b>z</b>	$\underline{z}_{0,95}$	$\bar{z}_{0,95}$	<b>z</b>	$\underline{z}_{0,95}$	$\bar{z}_{0,95}$	<b>z</b>	$\underline{z}_{0,95}$	$\bar{z}_{0,95}$	<b>z</b>	$\underline{z}_{0,95}$	$\bar{z}_{0,95}$
0	0,0	3,7	10	4,7	18,4	20	12,2	30,8	30	20,2	42,8	40	28,6	54,5
1	0,1	5,6	11	5,4	19,7	21	13,0	32,0	31	21,0	44,0	41	29,4	55,6
2	0,2	7,2	12	6,2	21,0	22	13,8	33,2	32	21,8	45,1	42	30,3	56,8
3	0,6	8,8	13	6,9	22,3	23	14,6	34,4	33	22,7	46,3	43	31,1	57,9
4	1,0	10,2	14	7,7	23,5	24	15,4	35,6	34	23,5	47,5	44	32,0	59,0
5	1,6	11,7	15	8,4	24,8	25	16,2	36,8	35	24,3	48,7	45	32,8	60,2
6	2,2	13,1	16	9,2	26,0	26	17,0	38,0	36	25,1	49,8	46	33,6	61,3
7	2,8	14,4	17	9,9	27,2	27	17,8	39,2	37	26,0	51,0	47	34,5	62,5
8	3,4	15,8	18	10,7	28,4	28	18,6	40,4	38	26,8	52,2	48	35,3	63,6
9	4,0	17,1	19	11,5	29,6	29	19,4	41,6	39	27,7	53,3	49	36,1	64,8
10	4,7	18,4	20	12,2	30,8	30	20,2	42,8	40	28,6	54,5	50	37,0	65,9

### 5.11.8 Particle concentration and dilution

For flawless particle registration and analysis it has to be monitored and maintained that the particle concentration at the counter is within its specified range of proper operation and that each individual particle count  $z_{\text{SAMPLE}}$  is well below the maximum count  $z_{\text{COUNTER\_MAX}}$ , such that

$$z_{\text{SAMPLE}} < 0,2 z_{\text{COUNTER\_MAX}}$$

To verify not over-concentrated, increase the dilution a known amount, and verify that the counts are decreased by the same ratio.

To verify not over-diluted, decrease the dilution and verify that the counts increase by this same change in dilution ratio.

### 5.11.9 Record keeping

A record with the following information shall be kept for each test of filtration efficiency and filtration efficiency and dust re-emission for the entire range of particle size:

- electrical and air-technical data of the type of at least 3 devices being tested;
- information on its dust receptacle and filter system;
- quantity of test dust being fed in the procedure;
- information on the particle analysis system:
  - particle counter and size ranges of analysed particle classes
  - dilution factors intake and exhaust
- for each particle count:
  - dilution factor
  - sample air volume analysed in the particle counter
  - particle counts in each class registered by the particle counter
- filtration efficiency (lower limit of 95 % - confidence range) of each particle class;
- filtration efficiency (lower limit of 95 % - confidence range) for entire range of particle size;
- dust re-emission for entire range of particle size;
- sheath air if applicable;
- vacuum cleaner air flow rate. 

## **6 Miscellaneous tests**

### **6.1 General**

The tests described in this clause are intended for the determination of such characteristics of a vacuum cleaner which relate to ease of handling or to the performance of the cleaner when together with its accessories or attachments it has been subjected to stresses likely to appear during normal use. The ability of a cleaner to resist such stresses may be verified by submitting it to the appropriate tests of Clause 5 as applicable.

### **6.2 Motion resistance**

#### **6.2.1 Purpose**

The purpose of this test is to determine the motion resistance, both for forward and for backward strokes, caused by friction when the cleaning head is moved over a carpet under normal operation conditions.

#### **6.2.2 Test carpet and test equipment**

A test carpet, in accordance with 7.2.1, which is free from dust, shall be used.

Test carpets designated for measurement of motion resistance shall not be used for other tests and shall be stored permanently at standard atmospheric conditions, hanging or lying flat, but not rolled.

The test carpet shall be fastened to a testing device, capable of measuring motion resistance of at least 100 N with an accuracy of 0,5 N of the measured value.

The principle construction of a suitable testing device is described in 7.3.9.

NOTE It is recommended to use a mechanical operator to simulate the test so that no additional force is exerted pressing the cleaning head against the carpet during the measurements (see 7.3.12).

#### **6.2.3 Determination of motion resistance**

The cleaning head is moved in double strokes with a stroke speed of  $0,50 \text{ m/s} \pm 0,02 \text{ m/s}$  over the test carpet. The cleaning head shall only be moved in pile direction, i.e. no tilting moment shall occur at the handle. Self propelled vacuum cleaners shall be operated at the specified speed, if possible. Otherwise, the speed shall be determined by the vacuum cleaner.

The motion resistance for 10 double strokes is measured when the cleaning head is moved with stroke speed by recording the force exerted to the test area either continuously or with a time slot pattern of  $\leq 100 \text{ ms}$ .

On the basis of the measured values the mean value and the range for the motion resistance are determined separately for forward and backward direction.

NOTE For a connecting tube with adjustable length, the length should be the same as that used during measurement of dust removal from carpets.

### **6.3 Cleaning under furniture**

#### **6.3.1 Purpose**

The purpose of the test is to determine the free furniture height, measured from the floor, for which the cleaning head can pass to reach a given insertion depth. The insertion depth is the depth, measured from the front surface of the furniture, from which test dust distributed on the surface to be cleaned can be removed (see Figure 12).

NOTE Standard atmospheric conditions according to 4.1 not required.

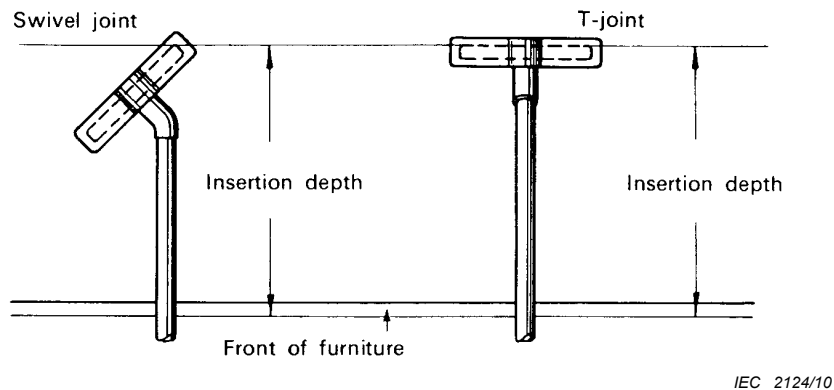

**Figure 12 – Insertion depth**

### 6.3.2 Distribution of test dust

Mineral dust, in accordance with 7.2.2.1, shall be distributed over a test carpet or a hard test floor. When distributed over a test carpet, the test dust shall not be embedded into the carpet.

### 6.3.3 Determination of free furniture height

The cleaning head is adjusted to the position intended for operation under furniture.

With the vacuum cleaner running at maximum continuous air flow, determine the free furniture height, in millimetres, necessary for the cleaning head to remove test dust up to the following insertion depths:

- 1,00 m: representing cleaning under a bed, a couch, etc.;
- 0,60 m: representing cleaning under a wardrobe, a cupboard, etc.

## 6.4 Radius of operation

### 6.4.1 Purpose

The purpose of the test is to determine the maximum distance between an electric socket-outlet and a spot on the surface to be cleaned with the handle in the normal operation position.

### 6.4.2 Conditions for measurement

The tube grip of cleaners with suction hose or the handle of other cleaners shall be held as for normal operation (see 4.6), the force applied in the direction of operation being 10 N maximum. The front edge of the cleaning head shall be at right angles to the direction of operation.

NOTE Standard atmospheric conditions according to 4.1 not required.

### 6.4.3 Determination of radius of operation

The radius of operation is determined as the maximum distance, to the nearest 0,05 m, between the front edge of the cleaning head and the face of the electric plug.

## **6.5 Impact resistance for detachable cleaning heads**

### **6.5.1 Purpose**

The purpose of this test is to determine the ability of a detachable cleaning head to resist impacts against walls, thresholds, etc., as in normal use, or other forms of careless handling, which otherwise might affect the performance of the vacuum cleaner.

NOTE Standard atmospheric conditions according to 4.1 not required.

### **6.5.2 Test equipment**

A drum for drop test, in accordance with 7.3.10, shall be used for this test.

### **6.5.3 Determination of impact resistance**

The cleaning head is placed in the drum, which then is set in operation. During the test, the cleaning head is taken out from the drum at suitable intervals to be inspected.

The test is continued until the cleaning head displays damage deemed to impair the performance of the cleaner, for example cracks causing leakage, joints no longer functioning, etc., or presence of sharp edges that could damage carpets, skirting boards, etc.

NOTE It is recommended that the test is discontinued after a maximum of 500 revolutions.

## **6.6 Deformation of hose and connecting tubes**

### **6.6.1 Purpose**

The purpose of this test is to determine the ability of the hose or connecting tubes to sustain a load, equivalent to a moderately heavy person, without being permanently deformed so as to impair the performance of the cleaner.

NOTE Standard atmospheric conditions according to 4.1 not required.

### **6.6.2 Test equipment**

The test equipment, as described in 7.3.11, consists of a screw press for applying a force on the test object; the force being read on a load indicator.

### **6.6.3 Determination of permanent deformation**

Prior to the test, the outside cross-sectional diameter of the test object is measured by a Vernier or digital calliper.

The test object is placed between the test plate and the carpet, according to Figure 18, and the screw is adjusted until the load indicator shows 0 on the scale. The force is increased to 700 N and kept at this level for 10 s, after which time the force is reduced to zero. In the case of a hose, it shall be left in free state (not stretched or compressed) during the test.

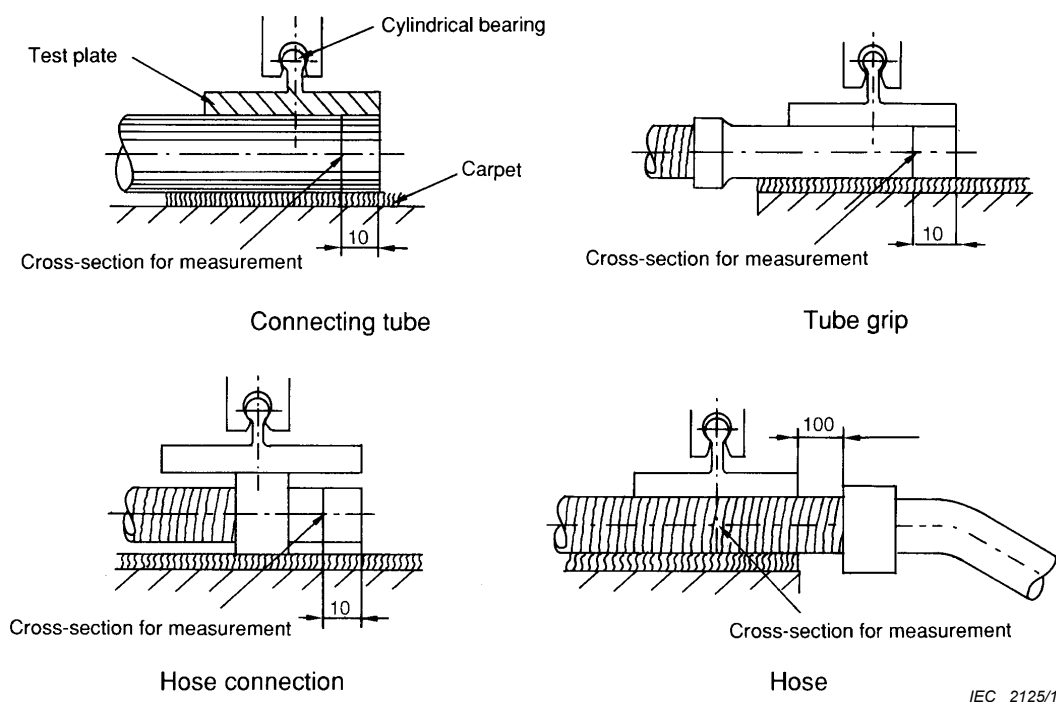

IEC 2125/10

*Dimensions in millimetres*

**Figure 13 – Position of test object and cross-section for measurement of deformation**

The reduced outside dimension is then measured after at least 1 min at the cross-section indicated in Figure 13 and the permanent deformation is expressed as the percentage reduction in the original outside diameter.

## 6.7 Bump test

### 6.7.1 Purpose

The purpose of this test is to determine the ability of vacuum cleaners to sustain stresses incurred when overrunning thresholds and bumping against doorposts. The test is only applicable to vacuum cleaners that in normal use are pulled by the user with the tube grip of the suction hose.

NOTE Standard atmospheric conditions according to 4.1 are not required.

### 6.7.2 Test equipment

The test shall be carried out on a flat hardwood floor allowing a running distance of  $2\text{ m} \pm 0,1\text{ m}$  and with provisions for fastening of the following test obstacles:

- a threshold made from polyamide 6 or of wood of equivalent hardness, with cross-sectional dimensions according to Figure 14, positioned at right angles to the centre line of the test surface at a distance of 1 m beyond the start position of the cleaner (see Figure 15);
- a doorpost made from sheet steel, with dimensions according to Figure 15, positioned at either side of the centre line at a distance of 2 m beyond the start position of the cleaner.

NOTE The wooden floor may be covered with a transport belt of rubber plastic for resetting the cleaner to its start position (see 6.7.4).

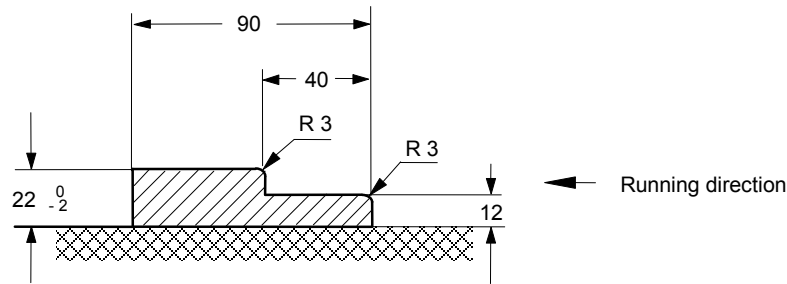

IEC 2126/10

**Figure 14 – Profile of threshold**

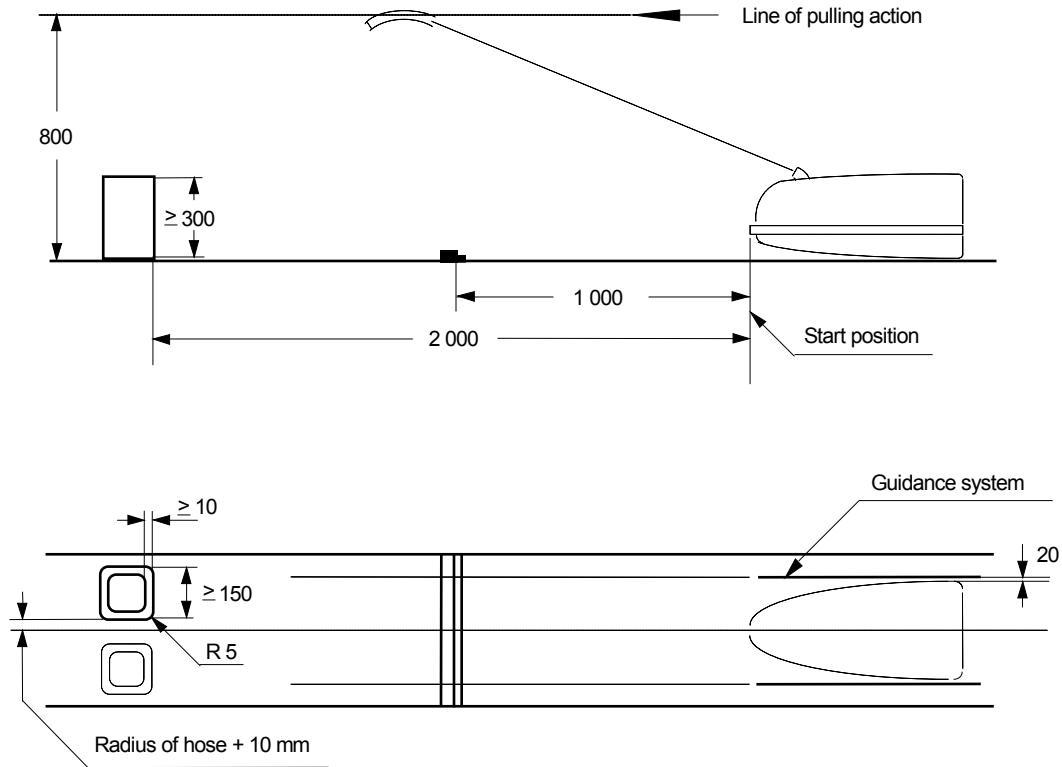

IEC 2127/10

*Dimensions in millimetres*

**Figure 15 – Arrangements for bump test**

The forward movement of the cleaner is brought about by applying a force to the tube grip, at a height of  $(800 \pm 50)$  mm above the test surface and along its centre line, so as to give the cleaner a velocity of  $1^{+0}_{-0,1}$  m/s at a distance of  $0,8^{+0,1}_{-0}$  m beyond its start position.

In order to keep the cleaner close to the centre line during the test, it is recommended to use either a guidance system with suitably low friction allowing a clearance of  $20^{+0}_{-5}$  mm on either side of the cleaner or a synchronous running trolley with adjustable side boards.



### 6.7.3 Test cycle

Each test cycle consists of a sequence of 22 forward runs comprising

- 10 overrunnings of the threshold;
- 1 bumping against a doorpost to the left (or right);
- 10 overrunnings of the threshold;
- 1 bumping against a doorpost to the right (or left).

### 6.7.4 Test procedure

Prior to the test, the cleaner shall be equipped with a clean dust receptacle and filters according to 4.5.

☐ Water filter vacuum cleaners are loaded with sand which has the equivalent weight of the nominal water according to the manufacturer's instructions. No water is used. ☐

In the case of overrunning of the threshold, the cleaner shall be allowed to come to rest softly at the end of the running distance by ceasing to apply the force to the tube grip when the cleaner has reached a distance of 1,5 m beyond its start position and by using an absorber made from foam rubber.

In the case of bumping against a doorpost, the force applied to the tube grip shall be such as to maintain the test velocity until the moment just before the bump.

After each run, the cleaner is reset to its start position avoiding the loading of its wheels or slide bars. Between each run, a pause of at least 5 s should be allowed.

During the test, the cleaner shall run intermittently with periods of 15 min on and 15 min off, which will not necessarily be synchronous with the test cycles.

After every 50th test cycle, the cleaner shall be examined for damages and for its proper function.

NOTE It is recommended that the test is discontinued after 500 test cycles.

## 6.8 Flexibility of the hose

### 6.8.1 Purpose

The purpose of this test is to determine the ability of the hose to avoid creasing that would restrict the air flow through the hose.

NOTE Standard atmospheric conditions according to 4.1 not required.

### 6.8.2 Preparation of test object

A length of 1,5 m of the hose is bent in shape of a U, in accordance with Figure 16, the free ends of the hose being clamped close together.

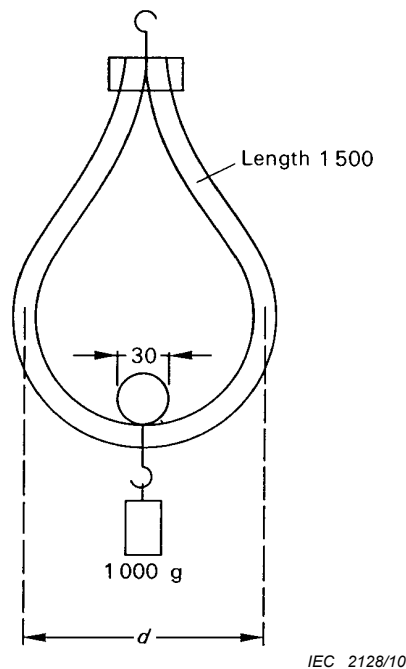

*Dimensions in millimetres*

**Figure 16 – Preparation of hoses for testing flexibility**

### 6.8.3 Determination of the flexibility of the hose

With the test object suspended by the clamp, the greatest distance  $d_0$  between the centre lines of the two legs of the U is measured 1 min after it has been hung up. The greatest distance  $d_{1\,000}$  between the centre lines of the two legs is measured again 1 min after the lowest point of the U has been loaded with a weight of 1 000 g.

The flexibility of the hose – higher values implies more flexibility – is calculated from the following formula:

$$\text{flexibility} = \frac{d_0 - d_{1\,000}}{d_0}$$

NOTE If the hose collapses, it should be stated in the test report.

## 6.9 Repeated bending of the hose

### 6.9.1 Purpose

The purpose of this test is to determine the ability of the hose to be repeatedly bent, as in normal use of the vacuum cleaner, before damage causes leakage affecting the performance of the cleaner.

- Ⓒ This test is only applicable to hoses that constitute the primary structural link between the floor-supported main body of a cylinder vacuum cleaner and a separate cleaning head or cleaning head/tube assembly that, in normal use, is used to clean a floor from an upright standing position (see Figure Z.1). Ⓒ

Ⓒ This test is not applicable to hoses that, in normal use, remain affixed at both ends to a vacuum cleaner with a cleaning head that, in normal use, forms an integral part of, or is permanently connected to, the vacuum cleaner housing. This configuration can often be found on upright vacuum cleaners. (see Figure Z.2). Such hoses may be released at one end to allow other cleaning tasks to be carried out (see Figure Z.3).

NOTE A test regarding durability of such hoses is under development.



**Figure Z.1 – Typical cylinder vacuum cleaner with primary hose**

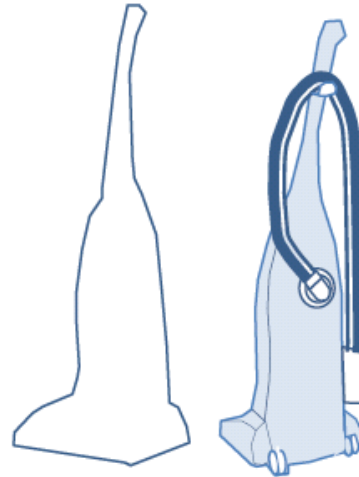

**Figure Z.2 – Typical upright vacuum cleaner with secondary hose (contour front and back)**

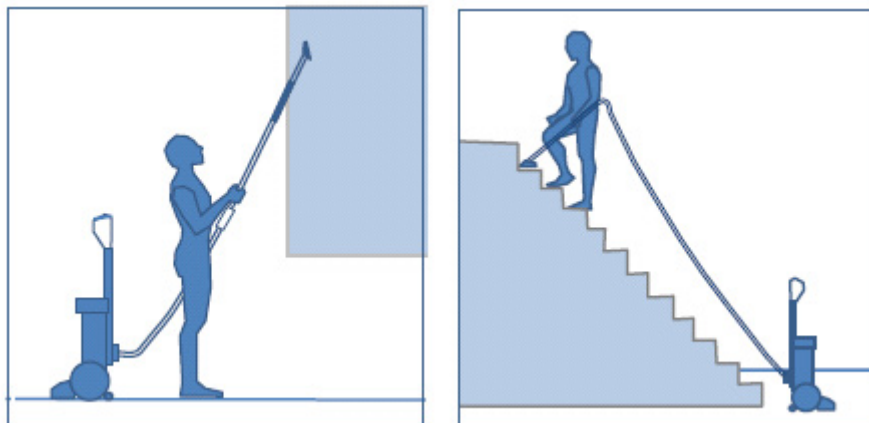

**Figure Z.3 – Typical upright vacuum cleaner with secondary hose used for cleaning curtains (left) and stairs (right).**

This test is not applicable for:

- Hoses that are permanently housed within other components of a vacuum cleaner, or that cannot be removed from a vacuum cleaner without the use of tools;
- Hoses that join two or more components, where, in all usage modes, the structural link between those components is provided by features other than the hose itself (an example is shown in Figure Z4);
- Hoses that are provided as additional accessories or where another primary hose is provided for general use. Ⓒ

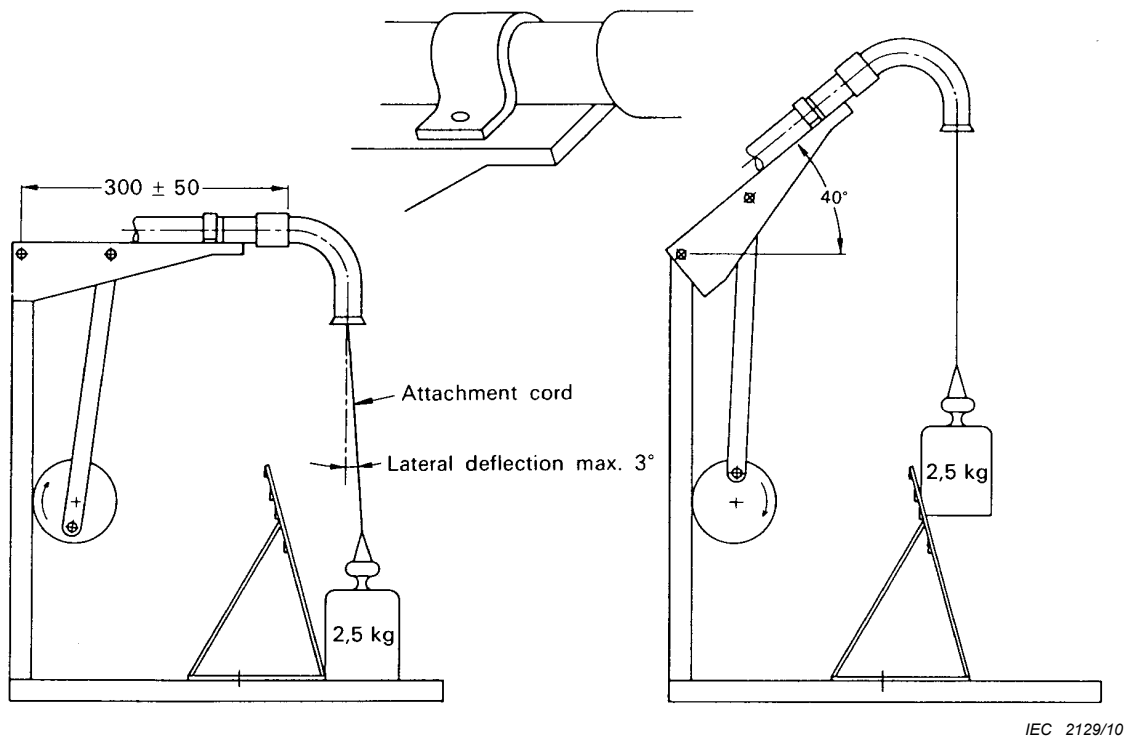

Figure Z.4 – Example of a hose joining two or more components. C

NOTE Standard atmospheric conditions according to 4.1 not required.

### 6.9.2 Test equipment

The test equipment, in accordance with Figure 17, consists of a pivoting lever with a clamping device for the attachment of the hose connector. The lever is operated by means of an oscillator, for instance the crank mechanism shown, to perform a raising and lowering movement with a frequency of  $(10 \pm 1)$  periods per minute. The initial position of the lever is its horizontal position from which it is raised to form an angle of  $40^\circ \pm 1^\circ$  with the horizontal plane.



*Dimensions in millimetres*

Figure 17 – Equipment for repeated bending of hoses

### 6.9.3 Test method

The hose connector is clamped to the lever so that the distance between the pivot point of the lever and the hose fitting end of the connector is  $300 \text{ mm} \pm 50 \text{ mm}$ .

A weight of 2,5 kg is attached to the pendent part of the hose in such a way that, during the oscillation period, it is lifted to a height of  $100 \text{ mm} \pm 10 \text{ mm}$  above the mounting plate and, during the remainder of the period, rests on the mounting plate to unload the hose completely. To accomplish this movement, the hose may need to be shortened to a length of about 300 mm.

NOTE 1 2,5 kg is the total of the weight, the attachment cord and its attachment to the hose.

In order to avoid pendulation of the weight loading the hose, it is given a lateral deflection of maximum  $3^\circ$  by means of an adjustable deflection plate.

The number of oscillations performed until the hose is damaged to the extent that it is deemed unusable is recorded. Additionally, breaking or damaging of the conductors, or an increase of more than 10 % of the conductor resistance, is considered to be a failure for current-carrying hoses.

NOTE 2 It is recommended that the test is discontinued after 40 000 oscillations.

## 6.10 Life test

### 6.10.1 Purpose

The purpose of this test is to determine the ability of the vacuum cleaner to maintain its air flow performance with a partly filled dust receptacle, representative of normal household use and household dust.

NOTE 1 Standard atmospheric conditions are not required.

NOTE 2 If the manufacturer's instruction provides for washing a filter, the filter should be replaced instead.

### 6.10.2 Test dust

Test dust in accordance with 7.2.2.3, see Figure 11, shall be used for loading the dust receptacle.

### 6.10.3 Test method

Prior to the test, the vacuum cleaner shall have been subjected to air data measurements (see 5.8) and dust emission / filtration measurement (see 5.11), then the dust receptacle shall be loaded with 50% of the amount of dust required according to 5.9.

The total mass of test dust, to be introduced into the vacuum cleaner, is prepared and fed into the vacuum cleaner in accordance with the description in 5.9.2.3.

With the loaded dust receptacle, the cleaner is allowed to run intermittently with periods of 14 min 30 s on and 30 s off. If the cleaner is provided with an agitation device, it shall be running but not in contact with the floor.

After  $50 \text{ h} \pm 5 \text{ h}$  of operation, the vacuum cleaner shall be equipped with a clean dust receptacle and new filters (see 4.5). Air data measurements shall be repeated and values recorded. Water filter vacuum cleaners are emptied and refilled with water according manufacturer's instructions every  $50 \text{ h} \pm 5 \text{ h}$ .

This procedure, with the receptacle loaded with the same amount of test dust as for the first cycle, shall be repeated in steps of  $50 \text{ h} \pm 5 \text{ h}$  to a recommended total time of 500 h.

Changing or maintenance of bags and filters shall be carried out in accordance to the manufacturer's instructions and this shall be recorded, see 4.5.

### 6.11 Mass

The mass of the vacuum cleaner, attachments and accessories, if any, shall be determined and reported. The mass of the vacuum cleaner includes the contribution of the power supply cord and the accessories placed inside the accessory compartment, if provided and shall be reported in grams.

NOTE Standard atmospheric conditions according to 4.1 not required.

### 6.12 Weight in hand

The purpose of this test is to determine the weight in the hand of the user when holding the tube grip or handle of the vacuum cleaner. The weight in hand is the static force in vertical direction.

To measure the force a vacuum cleaner according 4.6 is put on the floor in its normal operation conditions. Any telescopic suction wands or sticks shall be extended to maximum length.

A suitable force measuring device (e.g. a spring balance or similar) with an accuracy of 0,05 N is attached at the middle of the handle or grip. The tube grip or handle shall be held at a height of  $800 \text{ mm} \pm 50 \text{ mm}$ . The suction hose shall hang freely without any external force. If a cord is attached to the stick the cord shall be removed from the cord wrap/cord reel and extended to the rear of the cleaner such that the cord lies loosely on the ground.

The weight in hand shall then be recorded without moving the vacuum cleaner.

NOTE It is not necessary to operate the vacuum cleaner for this test.

### 6.13 Specific cleaning time

The time to clean an unobstructed area on a hard floor or a carpet may be calculated from the following formula:

$$t = \frac{2A}{v \times B}$$

where

$t$  is the cleaning time, in seconds;

$A$  is the area, in square metres;

$B$  is the cleaning head width, in metres;

$v$  is the stroke speed, in metres per second.

The specific cleaning time – the time to clean  $1 \text{ m}^2$  at a stroke speed of  $0,50 \text{ m/s} \pm 0,02 \text{ m/s}$  – is then given by

$$t_s = \frac{4}{B} \text{ s}$$

Although the obtained value does not account for lateral movement of the cleaning head, it may be considered as a good approximation both for parallel and zig-zag pattern (see Figure 4 for zigzag pattern).

#### **6.14 Dimensions**

Only those dimensions of importance for the storage of the vacuum cleaner shall be reported. All dimensions shall be reported in millimetres.

#### **6.15 Noise level**

See IEC 60704-1 and IEC 60704-2-1.

#### **6.16 Energy consumption**

The energy consumption figures for cleaning a carpeted test surface or hard floor surface with diagonal crevices are registered and in each case the equivalent figures for a 10 m<sup>2</sup> area covered by 5 double strokes (cleaned 10 times) are calculated.

The average energy consumption shall be calculated from the measurements for carpet and hard-floor and recorded separately for each surface.

When using an active cleaning head the energy consumption figures are in each case the sum of the values for the vacuum cleaner and the active cleaning head.

##### **6.16.1 Energy consumption when vacuuming of carpets**

###### **6.16.1.1 Test requirements**

This test is to be carried out with the mechanical test equipment described in 7.3.12.

The test carpet used shall be the Wilton carpet in accordance with 7.2.1.3.2. and pre-treated to remove loose pile in accordance with 7.2.1.4.

The vacuum cleaner is to be fitted with a new dust bag and filter equipment and is to be operated at maximum suction setting.

If a setting mechanism is available on the cleaning head, the operational mode "Carpet" is to be selected (the same as for testing dust removal from carpets).

###### **6.16.1.2 Test procedure**

A test surface with length 1 m and the width of the cleaning head is to be traversed with 5 double strokes at the given stroke speed of 0,5 m/s. With this the average effective power intake of the vacuum cleaner including the cleaning head is to be established.

NOTE When it is not possible to run the cleaner head at 0,5 m/s it is permitted to run it at its self-running speed on condition that this is specifically mentioned in the test report.

The areas to accelerate and decelerate the cleaning head are not taken into account. From the average effective power intake and the time taken for 5 double strokes, the average energy consumption for vacuuming of the traversed area is calculated. This figure, which is dependent on the cleaning head width (see 3.7), is then used to calculate a figure for a 10 m<sup>2</sup> area.

### 6.16.1.3 Establishing the average effective power intake

Measurement of the electrical effective power intake is carried out with an accuracy of 0,5% related to a measuring range of maximum 2500 W. The measuring equipment shall be controlled such that depending on the movement of the cleaning head at least 10 measurements are taken over each stroke length. The average effective power intake is then calculated as follows:

$$P_{\text{eff}} = \frac{1}{10} \times \frac{1}{n} \times \left[ \sum_{1}^{10} \left[ \sum_{i=1}^n P_{\text{eff}}(i) \right] \right]$$

where

$P_{\text{eff}}$  is the average effective power intake for 5 double strokes in Watts;

$P_{\text{eff}}(i)$  is the effective power intake in Watts per measurement;

$n$  is the number of effective power measurements/stroke ( $n \geq 10$ ).

### 6.16.1.4 Establishing energy consumption

The energy consumption per 10 m<sup>2</sup>,  $E(10 \text{ m}^2)$  with 5 double strokes, is calculated as follows,

with  $P_{\text{eff}}$  = average power intake;  
 $B$  = cleaning head width (m);  
 $v$  = stroke speed (0,5 m/s);  
 $E$  = energy consumption (W·s).

Covered area with the nozzle:

$$A_{\text{tot}} = N \times A$$

where

$A$  is the area to clean (10m<sup>2</sup>);

$N$  is number of cleaning processes (5 double strokes).

Total track length for cleaning  $A_{\text{tot}}$ :

$$s_{\text{tot}} = A_{\text{tot}}/B$$

Total cleaning time for 10 m<sup>2</sup> by 5 double strokes:

$$t_{\text{tot}} = s_{\text{tot}} / v$$

Input power:

$$E = P_{\text{eff}} \times t_{\text{tot}}$$

$$E = P_{\text{eff}} \times s_{\text{tot}}/v$$

$$E = P_{\text{eff}} \times A_{\text{tot}}/(B \times v)$$

$$E = P_{\text{eff}} \times N \times A/(B \times v)$$

And with 10 m<sup>2</sup>, 5 double strokes (10 strokes) and stroke speed of 0,5 m/s:

$$E = P_{\text{eff}} \times 10 \times 10/(B \times 0,5)$$

$$E = P_{\text{eff}} \times 200/B$$



## 6.16.2 Energy consumption with vacuuming of hard floors and hard floors with crevices

### 6.16.2.1 Test requirements

This test is to be carried out with the test equipment described in 7.3.12.

The test surface used shall be in accordance with 7.3.2. The crevice is to be prepared in accordance with Subclause 5.2. For hard floors only, the surface shall be as described in 5.1 or with a solid insert having no crevice cut into it.

NOTE No dust has to be filled into the crevice.

The vacuum cleaner is to be fitted with a new dust bag and filter equipment and is to be operated at maximum suction setting.

If a setting mechanism is available on the cleaning head, the operational type "Hard floor" is to be selected.

### 6.16.2.2 Test procedure

Similar as described in 6.16.1.2.

### 6.16.2.3 Establishing the average effective power intake

Similar as described in 6.16.1.3.

### 6.16.2.4 Establishing energy consumption

With  $P_{\text{eff}}$  measured in accordance with 6.16.1.3 and the energy consumption per 10 m<sup>2</sup>,  $E(10 \text{ m}^2)$  with 5 double stokes is calculated as follows:

$$E(10 \text{ m}^2) = P_{\text{eff}} \times 200/B$$

The results shall record whether the surface was solid, i.e. hard floor, or with crevice, i.e. hard floor with crevice.

## 6.23 Operational motor life-time test

### 6.23.1 Purpose

The purpose of this test is to determine the stationary operational life-time of a dry vacuum cleaner suction and agitation device motor.

### 6.23.2 Test method

The dry vacuum cleaner, equipped as in its normal operation with hose and tube (if applicable) and nozzle, shall be operated as stated in 4.6. It is allowed to run intermittently with periods of 14 min 30 s on and 30 s off in maximum power setting.

This test is operated with a half loaded receptacle; hence the dust receptacle shall be loaded with 50 % of the amount of test dust required according to 5.9.

Alternatively an empty dust receptacle can be used during the test. In this case the recommended testing time shall be increased by 10 % of the stated motor life value for testing with a half loaded dust receptacle. 

- Ⓒ The tube grip of dry vacuum cleaners with suction hose or the handle of other dry vacuum cleaners shall be held as for normal operation at a height of 800 mm ± 50 mm above the test floor.

The nozzle shall not be in contact with the floor, but lifted 1 cm off the floor.

If the dry vacuum cleaner is provided with an agitation device it shall be running. If manufacturer's instructions require different settings of the agitation device for use on carpets and use on hard floor, the agitation device shall be operated with the respective settings for 50% each of the total testing time.

Test with half loaded dust receptacle:

After 50 h ± 5 h of operation, the vacuum cleaner shall be equipped with a clean dust receptacle and new filters (see 4.5). This procedure, with the receptacle loaded with the same amount of test dust as for the first cycle, shall be repeated in steps of 50 h ± 5 h.

Test with empty dust receptacle:

After 100 h ± 5 h of operation, the vacuum cleaner shall be equipped with a clean dust receptacle and new filters (see 4.5).

Changing or maintenance of dust receptacles and filters shall be carried out in accordance to the manufacturer's instructions and this shall be recorded, see 4.5. End of life is reached when the suction motor and, if applicable, the agitation device stops operating or the recommended testing time has elapsed.

NOTE The 30 second off period is not included in the calculation of overall motor life. Ⓒ

## 7 Test material and equipment

### 7.1 General

This clause contains information on material and on the principal designs of suitable equipment to be used in various tests. It should be noted that only as far as possible the composition of a material (see Annex A) has been specified.

### 7.2 Material for measurements

#### 7.2.1 Test carpets

##### 7.2.1.1 General

The preferred test carpet for international testing and inter-laboratory comparative testing is the Wilton type carpet. There are three additional carpets of different quality related to cleaning performance that may be used. These carpets in verified versions are available from suppliers listed in Annex A. Specifications on this carpet types are given for guidance purpose in Annex C.

##### 7.2.1.2 Quantity and size of carpets

Separate test carpets are to be used for measurements with passive nozzles and with nozzles having rotating brushes, for measurements of fibre removal, thread removal or dust removal along walls, and for measurement of motion resistance. Each test carpet is duplicated, and preferably procured at the same time; one to be used as the actual test carpet and the other one as a reference carpet.

For measurements of thread removal, fibre removal and dust removal along walls, Wilton type carpet is to be used; a suitable size of the test carpet is 1,2 m weft and 2,0 m warp to provide a sufficient test area.

For measurement of dust removal from carpets and motion resistance, a suitable size of the carpet is 0,5 m weft and 2 m warp to provide a sufficient test area.

### **7.2.1.3 Type and quality of carpets**

#### **7.2.1.3.1 General**

Which ever carpet is selected for a test shall be declared in the results along with the reason for using that type.

NOTE Suppliers of verified carpets are listed in Annex A and guidance specification on carpets can be found in Annex C.

#### **7.2.1.3.2 Wilton Carpet**

This carpet is of Wilton type which is the preferred test carpet and shall be used for international comparative testing.

#### **7.2.1.3.3 Category A test carpet**

This carpet is a low looped polyamide carpet, normally relatively easy to clean and is an alternative for in-house laboratory testing and consumer tests as a complement to the Wilton type carpet.

#### **7.2.1.3.4 Category B test carpet**

This carpet is of tufted type (Plush) with medium high pile, normally moderate to clean and is an alternative for in-house laboratory testing and consumer tests as a complement to the Wilton type carpet.

#### **7.2.1.3.5 Category C test carpet**

This carpet is of tufted type (Shag) with high pile, often difficult to clean, and is an alternative for in-house laboratory testing and consumer tests as a complement to the Wilton type carpet.

### **7.2.1.4 Pre-treatment of carpets for dust removal testing**

A new carpet shall be pre-conditioned in the following manner before recordable testing is carried out.

Using a suitable vacuum cleaner all loose pile and fibre is removed over the entire surface of the carpet until an amount no greater than 0,5 g/m<sup>2</sup> is removed during the 5 min cleaning process. The weight of the carpet is recorded.

Using an in-house reference vacuum cleaner, a dust removal test according to 5.3 is carried out and the result recorded and plotted on a graph. This procedure is repeated until the resulting curve is flat and parallel with the horizontal axis and the difference between the average results of two consecutive tests is no greater than

- 1 percentage point for the Wilton carpet and the category C and
- 3 percentage points for the other carpets,

It is once more weighed and the result should be no more than 2 g higher than the weight recorded after the fibre removal. If so, then further cleaning runs should be made until this weight is within the 2 g tolerance allowed. This weight is the official carpet weight and is to be used between tests to minimize dust build up over the life of the carpet. The maximum allowable deviation from this weight is  $\pm 5$  g.

Separate carpets shall be used for active nozzles and passive nozzles. These separate carpets shall be clearly marked.

### 7.2.1.5 Verification of replacement carpets

The in-house reference vacuum cleaner shall be used to verify the suitability of replacement carpets when required. If the result is greater than 5 percentage points different to the original or first carpet used in the laboratory, then it may not be used.

### 7.2.2 Standard test dust

#### 7.2.2.1 Mineral dust – Type 1

The mineral dust shall consist of dolomite sand with the following grain size distribution and is used in the hard flat floor and hard floor with crevice tests.

Particle size range mm	Parts by weight %
< 0,020	20
0,020 < 0,040	10
0,040 < 0,075	10
0,075 < 0,125	10
0,125 < 0,25	20
0,25 < 0,5	16
0,5 < 1,0	11
1,0 < 2,0	3

#### 7.2.2.2 Mineral dust – Type 2

Measurements of dust removal ability from carpets is carried out with the following test dust:

- test dust: sieved from CEM 1 according to ISO 679;
- grain size: 0,09 mm / 0,20 mm.

#### 7.2.2.3 Simulated household dust

Test dust for establishment of the filled dust receptacle condition shall be a homogeneous mixture of

- 70 % by weight mineral dust, in accordance with the grain size distribution as stated in the table in 7.2.2.4;
- 20 % by weight cellulose dust (Arbocel);
- 10 % by weight second cut cotton linters.

<sup>A1</sup> The cotton linters shall be cut with an upper length of 4 mm with the following typical length range in a linters screening mill. The fibre length (*l*) may be checked using a Kajaani FiberLab<sup>4</sup> for example.

$l_m$  (mm): 2,05 (weight weighted length)  
Admissible scatter (mm):  $\pm 0,2$  <sup>A1</sup>

<sup>A1</sup> <sup>4</sup> Kajaani FiberLab is a trade mark and mentioning this does not constitute an endorsement by IEC. <sup>A1</sup>

<b>Fibre length range</b> mm	<b>Average relative fibre quantity</b> %	<b>Deviation</b> %
0 – 0,2	0,75	± 0,3
0,2 – 0,5	6,25	± 3
0,5 – 1,2	22	± 8
1,2 – 2,0	25	± 5
2,0 – 3,2	22	± 5
3,2 –	24	± 8

Before cutting, the linters shall have been pressed into a bale and stored at a temperature of (20 + 2) °C and a relative humidity of (40 + 5) %. The residual moisture of the cut linters shall not exceed 2,5 %.

Besides second cut linters, raw cotton which is cut to the appropriate length may also be used. <sup>A1</sup>

The test dust may be prepared by adding to a mixing vessel the separate components alternating in the following order: mineral dust, cellulose dust, cotton linters. The mixing vessel shall be part of the tumble mixer which can be operated at 28 r/min <sup>+3</sup><sub>-0</sub> r/min with a tilting angle of 150°/revolution. The test dust may also be obtained ready-mixed from the supplier, see Annex A.

NOTE 1 During transportation and storage of ready mixed test dust, a partial separation or compaction of the material in the container will occur. Therefore, it is recommended that the content of the container should be loosened gently. For such a homogenization the container may be slowly rotated in a laboratory tumbler mixer for a few minutes with 27 revolutions per minute and an angle of 150° or in a closed vessel by hand.

NOTE 2 <sup>A1</sup> The manufacturer of this test material shall ensure that the batch-wise inspection of the appropriate length and quality is carried out. A certificate shall be included to each linters supply with indication of life time and storage conditions. <sup>A1</sup>

#### 7.2.2.4 Mineral dust – Type 3

The mineral dust simulating household dust shall consist of dolomite sand with the following typical particle size distribution:

<b>Particle size range</b> mm	<b>Parts by weight</b> %
< 0,005	9
0,005 < 0,010	5
0,010 < 0,020	8
0,020 < 0,040	11
0,040 < 0,075	10
0,075 < 0,125	7
0,125 < 0,250	20
0,250 < 0,500	24
0,500 < 1,000	6
1,0000 < 2,000	0

#### 7.2.2.5 Mineral dust – Type 4

The mineral dust for measurement of dust emission is carried with test dust according to ISO 12103-1.

#### **A1** 7.2.2.6 Cellulose dust

Type	highly pure cellulose
Characteristic	microfibre, white
Cellulose content approximately	99,5 %
Average fibre length	30 µm
Average fibre thickness	18 µm
Bulk density	200 g/l – 260 g/l
Whiteness (absolute value at 461 nm)	85 % ± 5 %
Residue on ignition (850 °C, 4 h)	approximately 0,3 %
pH-value	6 ± 1
Screen residue (in accordance with DIN 53 734/ air jet sieve) with an interior mesh aperture of:	71 µm 32 µm (max. 0,1 % max. 3 %) <b>A1</b>

#### 7.2.3 Fibre material

For the determination of fibre removal ability, rayon tow according to the following specification is used:

natural carded viscose flock  
1,5 denier  
dry cut to 19 mm (0,75 in)  
no finish

#### 7.2.4 Thread material

For the determination of thread removal ability, pieces of mercerized cotton, thread 16 TEX (size 50) is used. The thread may be wound continuously around a suitable former and cut to length.

#### 7.2.5 Moulding granules

For the determination of the maximum usable volume of the dust receptacle, injection moulded granules of thermoplastic elastomer (Kraton G7705-Evoprene 961) are used.

#### 7.2.6 Test cushion

The test cushion consists of a core of foam material, with a layer of fleece material glued to both surfaces of the core, and a closely fitting cushion slip.

The core material shall be of polyurethane-polyether with open voids and to the following specification:

- density 35 kg/m<sup>3</sup>
- compression 40 % per 4,4 kPa according to ISO 3386-1
- indentation 40 % per 160 N according to ISO 2439
- dimensions 800 mm × 550 mm × 80 mm

The fleece material shall be of voluminous polyester by weight of 100 g/m<sup>2</sup>.

The cushion slip shall be made from upholstery material according to the following specification:

<b>A<sub>1</sub></b> type	MEDT001/Q63 Blue fabric
pile repeat	100 % V weave
basic fabric	Cotton 3/12's Ne, 2/12'sNe
pile yarn	2/16's worsted 83 % wool/17 % nylon
weight	820 g/m <sup>2</sup>
thickness	4,3 mm
pile weight	510 g/m <sup>2</sup>
pile height	3,3 mm
number of tufts	36,6 cm <sup>2</sup> <b>A<sub>1</sub></b>

The cushion slip is made with the weft of the upholstery material in parallel to the 800 mm long sides of the cushion and shall be provided with a zip fastener in the centre of one of its long sides. To achieve a sufficient compression of the foam core, the dimensions of the slip shall be 5 % less than the dimensions of the core.

### 7.3 Equipment for measurements

#### 7.3.1 Floor test plate

Tests relating to hard flat floors are carried out on a floor test plate of untreated laminated pine wood or equivalent panel, at least 15 mm thick. Recommended dimensions are 0,5 m × 2,0 m for mechanical operator and 1,2 m x 1,8 m for dust removal along walls.

#### 7.3.2 Test plate with crevice

**C** The equipment consists of a wood panel provided with a removable insert of aluminium having a 3 mm ± 0,05 mm wide and 10 mm ± 0,05 mm deep smooth crevice (see Figure 18). **C**

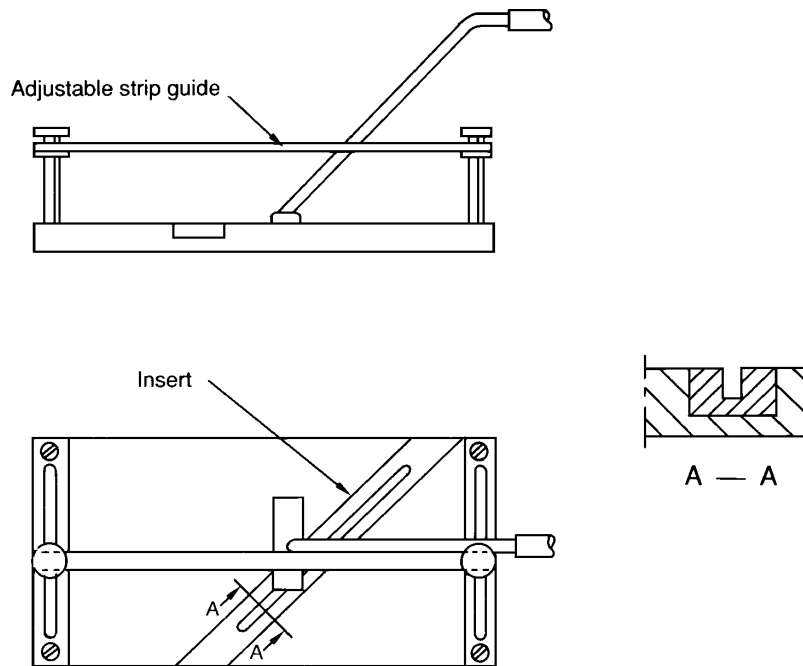

IEC 2130/10

The length of the crevice should be about twice the outside width of the cleaning head.

**Figure 18 – Test plate with crevice**

### 7.3.3 Carpet-beating machine

A machine suitable for removing all residual dust shall not damage the carpet. One suitable design consists of a horizontal cylinder provided with thongs to beat the backing of the carpet when it is fed back and forth under the rotating cylinder (see Figure 19).



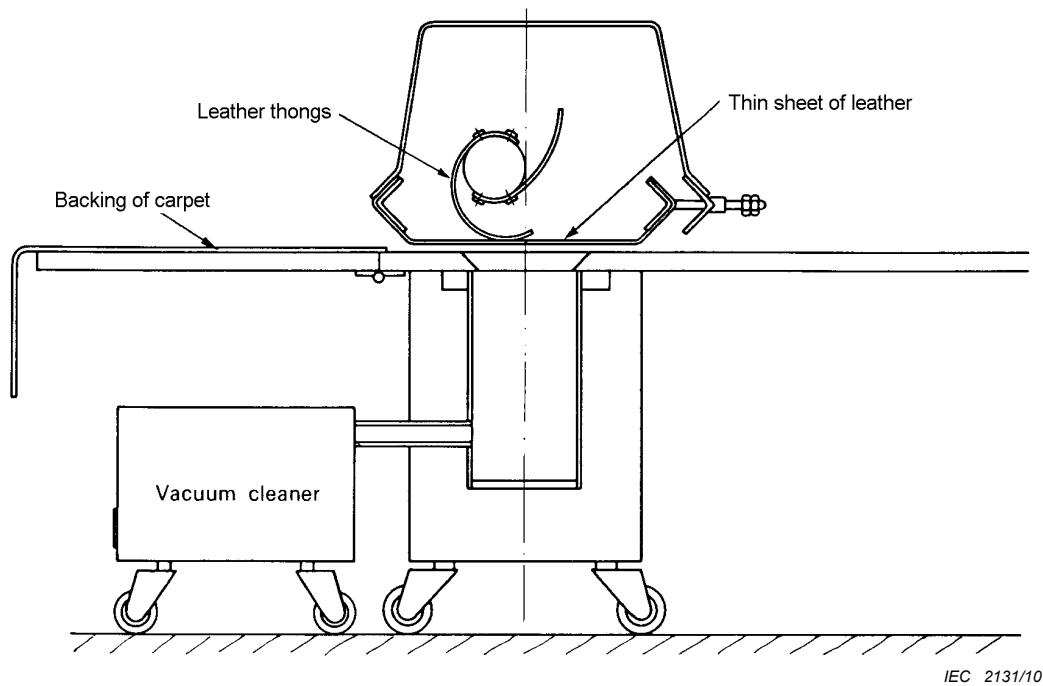

**Figure 19 – Carpet-beating machine**

#### 7.3.4 Hold-downs and guides

The two hold-downs shall be at least 1,4 m × 0,05 m × 0,05 m in dimension and weigh 10 kg each. They shall be designed in such a way so as not to obstruct the air flow at the sides of the cleaning head (see Figure 20). It is recommended that the edges of the hold-downs adjacent to the cleaning head are treated to reduce friction.

NOTE Low-friction adhesive tape may be used to reduce friction.

The hold-downs shall be placed on either side of the test area with a clearance of not more than 2 mm on both sides of the cleaning head.

#### 7.3.5 Dust spreader

The device consists of a tray extending across the width of the test area and mounted on a trolley, which can be moved along the length of the test area without impinging upon it. When the trolley is moved back and forth over the test area, a vibratory action causes the test dust, which has been placed evenly along the tray, to emerge from a line of suitably sized holes along the base of the tray, equally spaced and sufficient in number to cover the test area uniformly with test dust.

The vibratory action may be brought about by an incorporated vibrator or by the trolley running on spur racks as indicated in Figure 21.

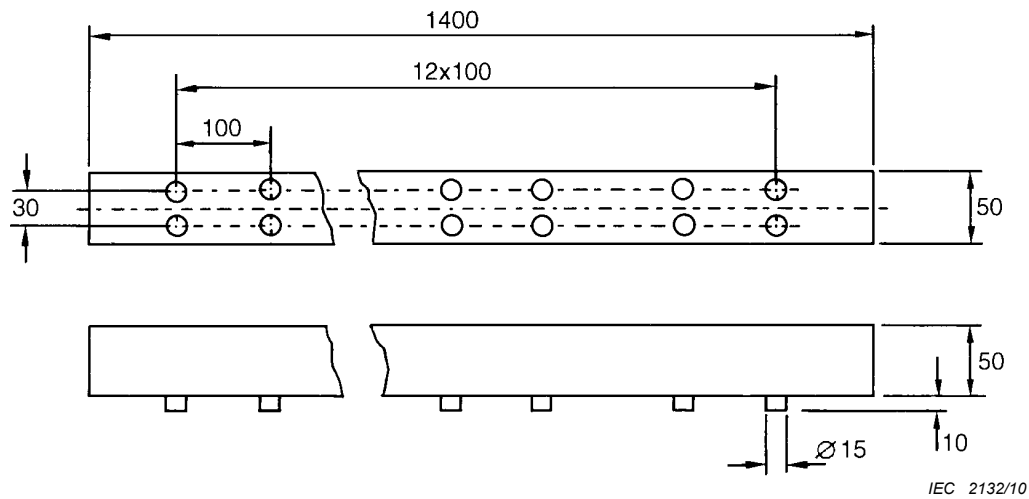

*Dimensions in millimetres*

**Figure 20 – Carpet hold-downs and guides**

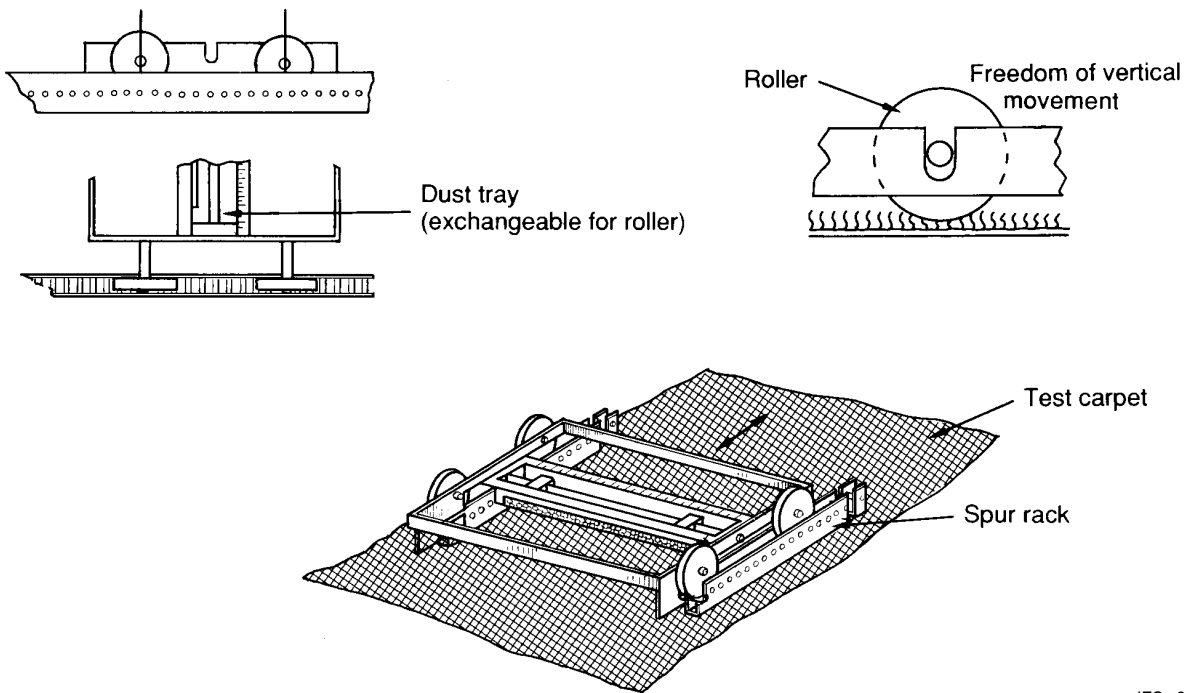

**Figure 21 – Dust spreader and roller for embedding dust into carpets**

### 7.3.6 Rollers for embedding

#### 7.3.6.1 Dust embedding roller

The roller shall have a diameter of 50 mm and a length of at least 380 mm such that it is at least 20 mm longer than the dust covered area width. The roller is preferably made of steel and polished. It can be provided with a handle for rolling by hand or be driven by a motorized unit.

The mass of the roller, if applicable, shall be 10 kg/m. The roller may be incorporated into the dust spreader as indicated in Figure 21.

### 7.3.6.2 Fibre and thread embedding roller

The roller shall have a diameter of 70 mm and a mass of 30 kg/m. The roller is preferably made of solid steel and polished. It can be provided with a handle for rolling by hand or be driven by a motorized unit. A convenient mass for rolling by hand is 15 kg.

### 7.3.7 Equipment for air data measurement

#### 7.3.7.1 General

The overall accuracy of the air data measurement shall be  $\pm 2\%$ .

Two alternatives of equipment are provided, each comprising a wattmeter and a measuring box, to which the vacuum cleaner, a vacuum-meter and means for setting the airflow are connected. The test report shall state which alternative has been used to obtain the air data.

The measuring box shall be made of sheet steel and shall allow the connection of all types of vacuum cleaners. The interior edges of adaptors for the connection of the suction duct, the hose or the connection tube of vacuum cleaners shall be well rounded with a radius of at least 20 mm to prevent interference from contraction and deflection of the air stream.

Measured air data shall be corrected to standard air density conditions and rated voltage (see 7.3.7.5).

#### 7.3.7.2 Alternative A

The test set-up and details of the measuring box are shown in Figures 22 and 23, respectively.

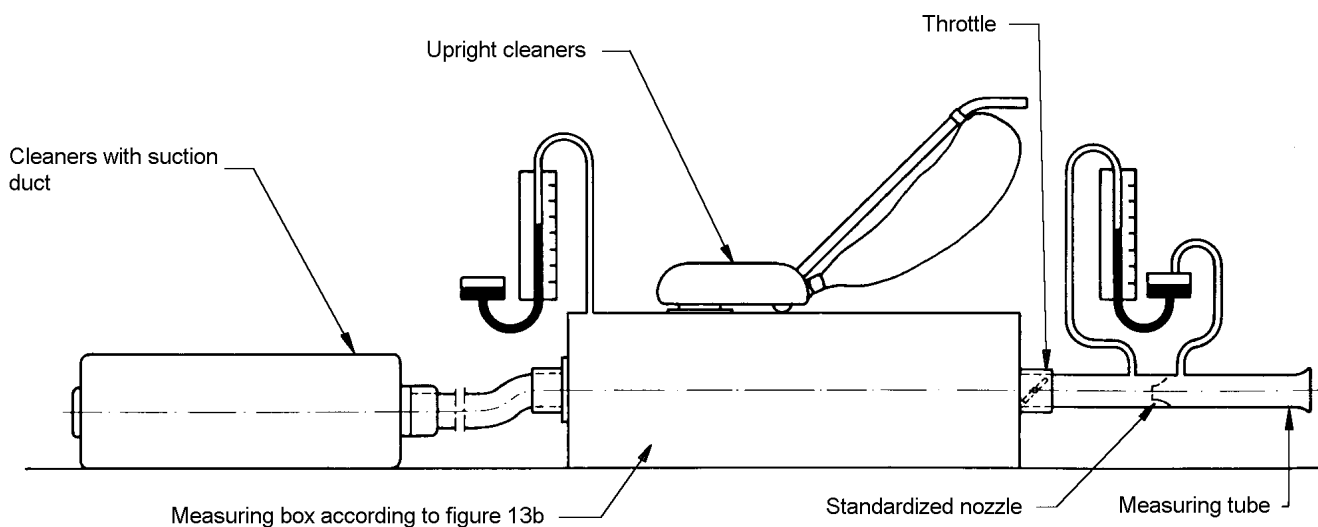

IEC 2134/10

Figure 22 – Alternative A equipment for air data measurements

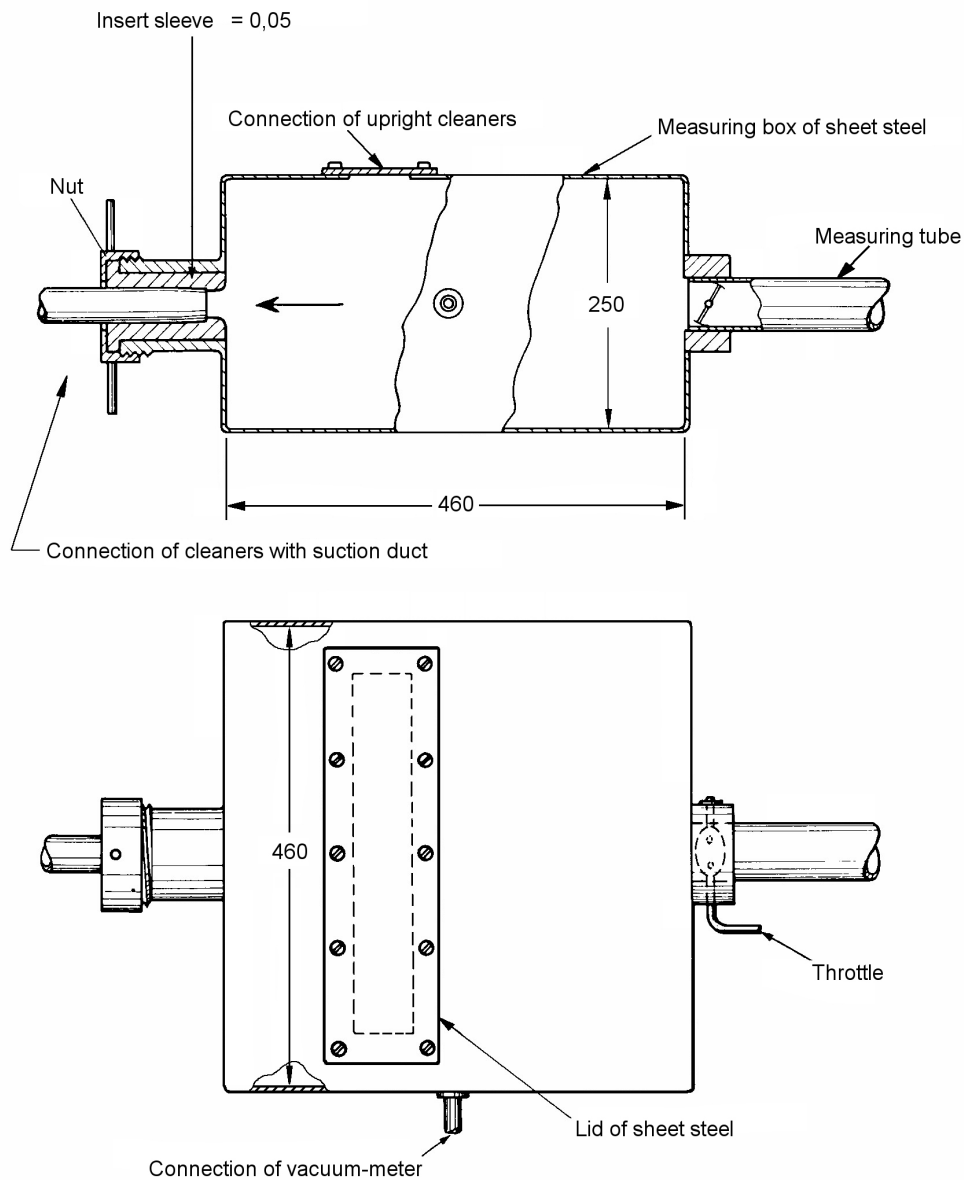

IEC 2135/10

Dimensions in millimetres

**Figure 23 – Measuring box for alternative A**

The air flow is established by means of a throttle and a measuring tube with a suitable nozzle or orifice plate in accordance with ISO 5167-1 (see Figure 22).

NOTE 1 A valve-gated air flow opening to realise the intermediate unthrottled operation according to 5.8.4 is applied having in open situation an air flow resistance equal or lower than orifice size 8 (see 7.3.7.3).

The air flow is controlled by at least 10 fixed, preselected positions of the throttle valve. The air flow resistance of these positions approach the air flow resistance of the various orifices of 7.3.7.3 alternative B.

At standard air conditions, the air flow  $q$  is given by the following equation:

$$q = K(h) \sqrt{h_d} \quad (\text{l/s})$$

where

$h_d$  is the differential pressure of the measuring tube standardized nozzle or orifice plate, in kilopascals;

$K(h)$  is the flow coefficient of the nozzle or orifice plate, based on the calibration data of the applied sample.

NOTE 2 An extra separate cooling aid as indicated in 5.8.4 can be part of the measuring box. For instance a valve gated air flow opening, having in open position an air flow resistance equal to or lower than the initial minimum flow resistance of the measuring equipment alternative A.

NOTE 3 The alternative A measuring box dimensions are not restricted to the 460 mm × 460 mm × 250 mm given in Figure 23; the 500 mm × 500 mm × 500 mm dimensions of the measuring box B in Figure 24 is a granted alternative and is recommended where maximum airflows are greater than 40 l/s.

NOTE 4 The measuring tube may be replaced by a tube containing any sort of air flow meter, for instance a gas flow meter, capable of giving the same measuring result as ISO 5167-1.

### 7.3.7.3 Alternative B

The measuring box (see Figure 24) shall be 500 mm × 500 mm × 500 mm in internal dimensions with provisions for fastening replaceable orifice plates to establish the air flow. The outlet for connection of the vacuum-meter shall be located in the vicinity of a corner within 15 mm from adjacent walls.

NOTE 1 Where maximum airflows are less than 40 l/s it is permissible to use the smaller plenum chamber identified in alternative A.

NOTE 2 An extra separate cooling aid as indicated in 5.8.4 can be part of the measuring box. For instance a valve gated air flow opening, having in open position an air flow resistance equal to or lower than the initial minimum flow resistance of orifice size 9 (see table below).

A valve-gated air flow opening to realise the intermediate unthrottled operation according to 5.8.4 is applied having in open situation an air flow resistance equal to or lower than orifice size 9 (see table below).

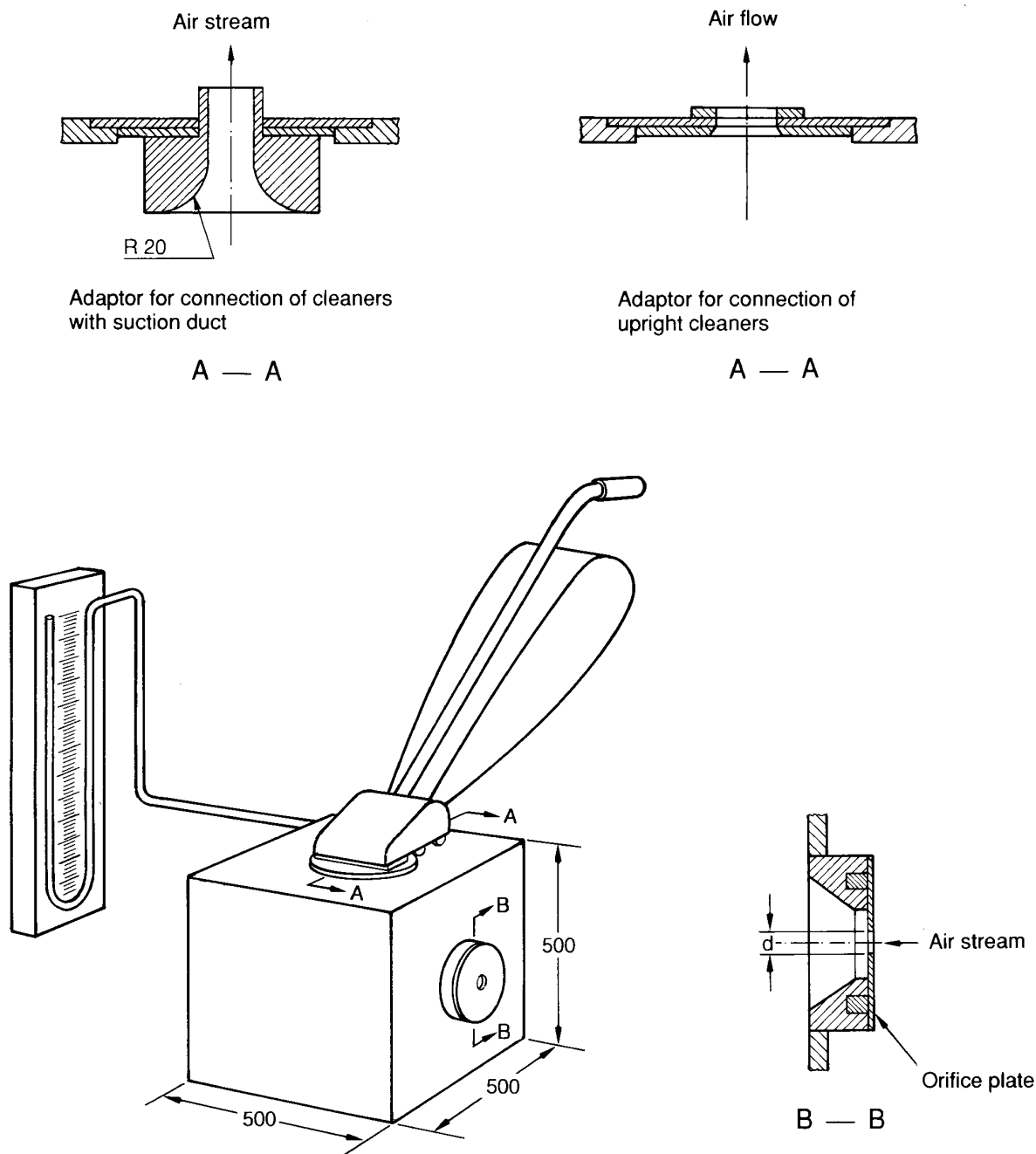

IEC 2136/10

Dimensions in millimetres

**Figure 24 – Alternative B equipment for air data measurements**

The air flow is controlled by means of a set of 10 orifice plates with varying orifice sizes and is determined from the observed values of the vacuum. The orifice plates shall be made of sheet steel,  $2 \text{ mm} \pm 0,1 \text{ mm}$  in thickness, and have sharp-edged circular openings with nominal diameters  $d_0$  as follows:

Size	0	1	2	3	4	5	6	7	8	9
$d_0$ (mm)	0	6,5	10	13	16	19	23	30	40	50

The orifice plates shall be air-tightly mounted, either in front of an opening in the measuring box or on a protrusion. The flow of air into the box shall be free of disturbance within a hemisphere with a radius of at least 0,5 m, and having passed the orifice, it shall be free of disturbance from built-in parts within a conical region with an angle of 90° relative to the largest orifice diameter.

At standard air conditions, the air flow  $q$  is given by the following:

$$q = \alpha \times 0,032 d^2 \sqrt{h} \quad \text{l/s}$$

$$\alpha = 0,595 + 0,0776 \frac{s}{d} - 0,0017 h$$

where

- $\alpha$  is the orifice coefficient;
- $d$  is the orifice diameter, in millimetres;
- $h$  is the vacuum, in kilopascals;
- $s$  is the thickness of the orifice plate, in millimetres.

Deviations of more than 0,01 mm from the nominal orifice diameter shall be taken into account when calculating the air flow.

If bevel-edged orifices are utilised, the flat surface shall face outwards from the measuring box.

#### 7.3.7.4 Instrumentation

The wattmeter for measuring input power shall have an accuracy according to IEC 60688 class 0,5.

The vacuum-meter shall have an accuracy of  $\pm 0,05$  kPa.

The vacuum-meter for measuring the differential pressure over the standardized nozzle in the measuring tube (7.3.7.2) of alternative A shall have an accuracy of 0,5 % full scale. The residual zero drift differential pressure signal measured with the throttle valve closed is used to correct the preceding differential pressure reading.

The barometer for measuring the ambient air pressure shall not be corrected for sea level and shall have an accuracy of  $\pm 0,2$  kPa.

The thermometer for measuring ambient air temperature shall have an accuracy of  $\pm 1$  °C. The ambient air temperature is measured at the air inlet of the measuring box.

The thermometer for measuring the exhaust air temperature shall have an accuracy of  $\pm 1$  °C.

The meter for measuring the relative humidity RH of the ambient air shall have an accuracy of  $\pm 3$  %.

A regulated electrical mechanical mains transformer system connected to the public power line, having the rated frequency with a maximum total harmonic distortion of 3 % combined with a voltmeter for measuring the applied regulated voltage.

The voltmeter for measuring the real time line voltage shall have an accuracy according to IEC 60688 class 0,2.

### 7.3.7.5 Correction to standard air density at the rated voltage value

Series-wound motors, commonly used in vacuum-cleaners, are to a certain extent sensitive to thermodynamic changes in air density as regards motor loading and speed of rotation. To account for the interaction between air density and common characteristics of series-wound motors, measured air data shall be corrected to standard air conditions.

The performance characteristics of vacuum cleaners with series-wound motors have a known relationship to small voltage deviations. To account for this relationship data measured at line voltage  $V_m$  outside the rated voltage value range  $\frac{V_{rv} - V_m}{V_{rv}} \pm 0,25 \%$  shall be corrected to the rated voltage value.

The corrected value of the vacuum  $h$  is given by

$$h = h_m D_m^{-0,67} \left( \frac{V_{rv}}{V_m} \right)^{+1,33} \quad (\text{kPa})$$

The corrected value of the differential pressure  $h_d$ , alternative A, is given by

$$h_d = h_{dm} D_m^{-0,67} \left( \frac{V_{rv}}{V_m} \right)^{+1,33} \quad (\text{kPa})$$

The corrected value of the air flow  $q$  is calculated from the corrected values of the differential pressure  $h_d$  (Alternative A) or vacuum  $h$  (Alternative B).

The corrected value of the input power  $P_1$  is given by

$$P_1 = P_{1m} D_m^{-0,5} \left( \frac{V_{rv}}{V_m} \right)^{+2,00} \quad (\text{W})$$

NOTE 1 For alternative types of air flow meters (7.3.7.2 NOTE 4) the corrected value of the airflow is given by

$$q = q_m D_m^{+0,17} \left( \frac{V_{rv}}{V_m} \right)^{+0,67} \quad (\text{l/s})$$

NOTE 2 The fan/motor speed is often relevant in a development environment. The corresponding correction formula is given by

$$n = n_m D_m^{+0,17} \left( \frac{V_{rv}}{V_m} \right)^{+0,67} \quad (\text{s}^{-1})$$

For alternative A,  $q_m$  is derived from the pressure difference measured by the measuring tube or from the (not air density corrected) air flow meter readings.

$$D_m = \frac{p_m + \Delta p_{RH}}{101,3} \times \frac{293}{t_m + 273}$$

and

$$\Delta p_{RH} = 0,001 \times [ 0,44 - RH \times (2,32 + 0,212 t_m + 0,00028 t_m^3) ]$$



where

- $V_m$  is the measured real time line voltage, in Volt (V);
- $V_{rv}$  is the rated voltage value, in Volt (V);
- $p_m$  is the measured ambient air pressure, in kilopascals (kPa);
- $t_m$  is the ambient temperature measured in the measuring box, in degrees Celsius (°C);
- $n$  is the measured motor speed (s<sup>-1</sup>);
- $h_m, q_m, P_{1m}$  are the values measured at the line voltage at ambient air conditions;
- $h, q, P_1$  are the values corrected to rated voltage and standard air conditions;
- $RH$  is the relative humidity, in %;
- $\Delta p_{RH}$  is the ambient pressure correction term, valid for ambient temperature  $t_m < 35$  (°C) and relative humidity  $RH < 80$  %.

### 7.3.7.6 Estimate the maximum value of suction power and the airflow

Linear regression analysis  $h = \alpha + \beta \times q$  on succeeding measuring points of the air flow curve  $h(q)$  shall be applied to estimate the maximum value of the suction power  $P_{2max}$  and the theoretic maximum value  $q_{max}$  of the airflow.

The influence of an operating safety valve or input power limiting regulations should be noted and measuring points affected by it omitted from the regression calculation.

The calculated airflow value  $q_1 = -\alpha_1 / (2 \times \beta_1)$  corresponding with the maximum suction power  $P_{2max} = -\alpha_1^2 / (4 \times \beta_1)$  shall be within the range of four succeeding measuring points on a linear regression curve  $h = \alpha_1 + \beta_1 \times q$ .

If not, the calculated  $P_{2max}$  is omitted and the maximum measured suction power value reported as maximum value.

The calculated theoretic maximum value  $q_{max} = -\alpha_2 / \beta_2$  of the airflow shall be based on three succeeding measuring points (including the maximum measured airflow value) on a linear regression curve  $h = \alpha_2 + \beta_2 \times q$ .

Both  $P_{2max}$  and  $q_{max}$  shall be reported separately from the measured values.

If the regression coefficient is less than 0,9, the maximum measured value shall be reported.

### 7.3.8 Test equipment for determining the fractional filtration efficiency of the vacuum cleaner

#### 7.3.8.1 General

The test equipment is comprised of a test hood, a dust feeder and a particle analysis system including equipment for sampling the aerosol [C] intake [C] and [C] exhaust [C]. All surfaces which may come in contact with the intake or exhaust aerosol are required to have low adhesion for the test dust, being preferably metallic and having a smooth finish.

### 7.3.8.2 Test hood

The test hood is shaped as shown in Figure 25. It contains a base plate with edge rails bent upright. For inserting the vacuum cleaner and for connecting the hose and electrical cables the test hood will have appropriate openings which can be closed airtight when the vacuum cleaner is in operation. The upper end of the test hood tapers to the form of a short pipe of  $d_i = 100$  mm inner diameter which connects to the exhaust chimney.

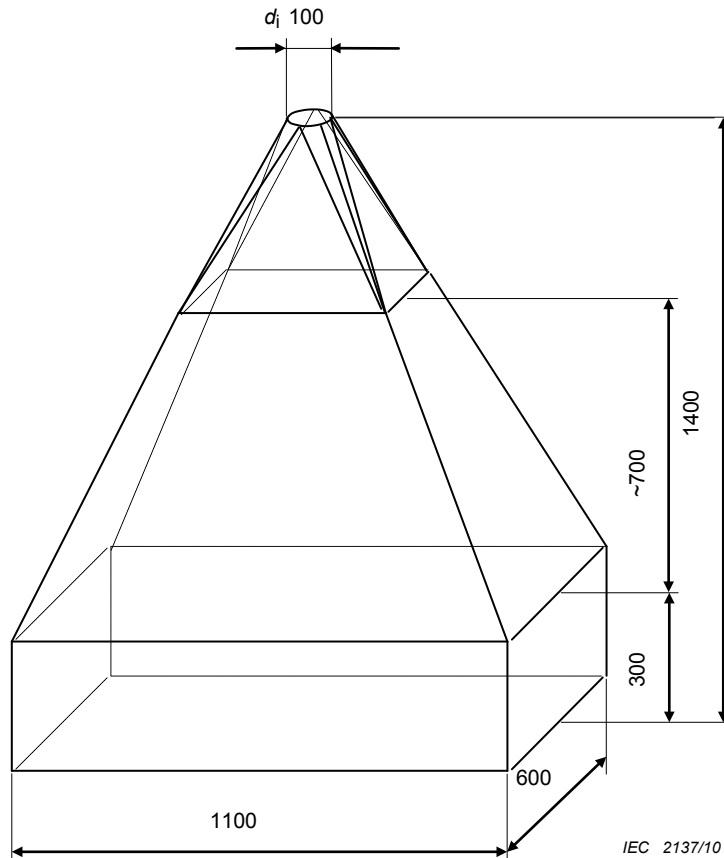

*Dimensions in millimetres*

**Figure 25 – Test hood**

### 7.3.8.3 Dust dispenser

The dust dispenser evenly supplies the provided quantity of test dust and disperses the dust into the aerosol channel (see Figure 26) in order to generate the required concentration,  $c = 0,1 \text{ g/m}^3$  of test dust in the air intake of the vacuum cleaner.

A suitable device consists of a dust reservoir with a portioning and feeding appliance, and a dispenser nozzle operating at air flow of  $5 \text{ m}^3/\text{h}$  to  $20 \text{ m}^3/\text{h}$  according to ISO 5011. The aerosol is blown from the dispenser nozzle into an aerosol channel of  $d_i = 100 \text{ mm}$ , the end of which provides a conical transition to the hose adapter of  $d_i = 30 \text{ mm}$ .

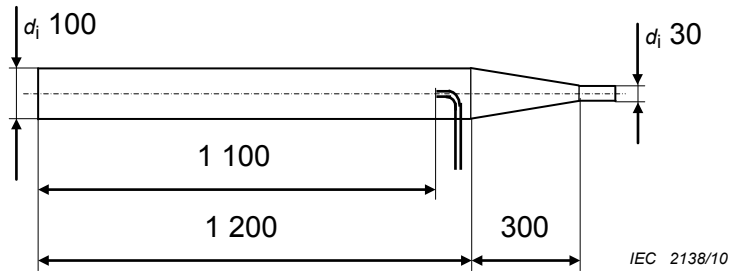

Dimensions in millimetres

Figure 26 – Aerosol channel with sampling probe

#### 7.3.8.4 Exhaust channel

The entire exhaust air of the vacuum cleaner under the closed test hood has to be conducted through an exhaust channel, as shown in Figure 27.

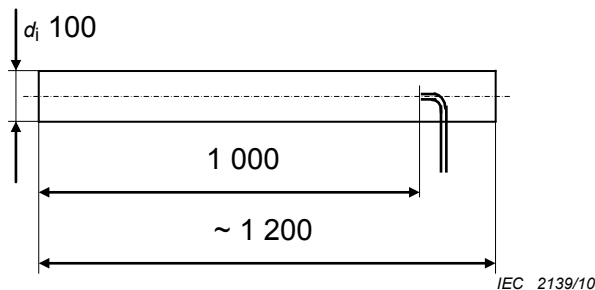

Dimensions in millimetres

Figure 27 – Exhaust channel with sampling probe

NOTE Equipment described in ASTM F1977 may also be used.

#### 7.3.8.5 Particle analyzer system

The test requires taking aerosol samples, under comparable conditions, of intake air entering, and of exhaust air leaving the vacuum cleaner. Air samples shall be taken isokinetically, i.e. the speeds of air flow in the channel,  $v_{channel}$ , and at the entry of the sampling system,  $v_{probe}$ , are required to satisfy the relation

$$0,8 < v_{probe} / v_{channel} < 1,2.$$

The inner diameter of the sampling tube has to conform to the inner diameter of the entry to the analysis system and should be designed as to minimize changes to the sample air.

In order to satisfy these conditions, an aerosol dilution system may be employed which reduces the particle concentration in the aerosol sample entering the particle counter, relative to the particle concentration in the aerosol sample being taken from the channel, by a definite and reproducible dilution factor, without altering the population ratios between particle size classes.

The analyzer should be an optical particle counter preferably with a volumetric flow of 28,3 l/min [1cfm] for particle sizes from [C] at least [C] 0,3  $\mu\text{m}$  to at least 10  $\mu\text{m}$ . [C] For the determination of fractional filtration efficiency these [C] particle sizes are divided into geometrically graded classes, where the size interval  $q$  is determined by

$$q = (D_{OK} / D_{UK})^{(1/k)}$$

where

$D_{UK}$  is the minimum recorded particle size;

$D_{OK}$  is the maximum recorded particle size;

$k$  is the number of particle classes.

To reduce the statistical interference, the size interval  $q$  should be  $< 2$ .

For particle counters with at least 8 configurable size classes the graduation given in Table 2 is prescribed.

**Table 2 – Graduation of 8 size classes for particle sizes 0,3  $\mu\text{m}$  – 10  $\mu\text{m}$**

Class (k)	1	2	3	4	5	6	7	8
$d_{uk}$ [ $\mu\text{m}$ ]	0,3	0,5	0,7	1,1	1,7	2,7	4,2	6,5
$d_{ok}$ [ $\mu\text{m}$ ]	0,5	0,7	1,1	1,7	2,7	4,2	6,5	10

Ⓒ For the determination of filtration efficiency and dust re-emission for the entire range of particle size this particle size range is divided into classes in such a way that one class has the lower limit of 0,3  $\mu\text{m}$  and one class has the upper limit of 10  $\mu\text{m}$ . Ⓒ

### 7.3.9 Device for motion resistance test

The device comprises a wooden plate on which the test carpet is fixed with two hold-downs.

The handle of the vacuum cleaner shall be moved over the test area according to the conditions described for dust removal from test carpets.

For the determination of motion resistance the test plate shall be designed such that the force exerted between cleaning head and carpet in pile direction can be measured in a range from 5 N to at least 100 N.

The test set-up shall be constructed in a stiff and low frictional way in order to prevent a distortion of the measurement results. The inherent frequency of the set-up shall be greater than 35 Hz. The measurement values shall be recorded analogue or with a time slot pattern smaller or equal to 100 ms.

One realisation comprises a solid base frame, on to which a stiff test plate is arranged connected to the base via flexible elements in pile direction. The exerted force can be deducted from the flexibility of the connecting elements directly or indirectly from the deflection of the test plate.

The described equipment can be incorporated in a mechanical operator as described in 4.8.

### 7.3.10 Device for impact test

The device consists of a drum of sheet steel provided with an inspection window and with floors made of sheet steel, 5 mm in thickness, covered with 20 mm thick plates of oak or material of equivalent density and stiffness (see Figure 28).

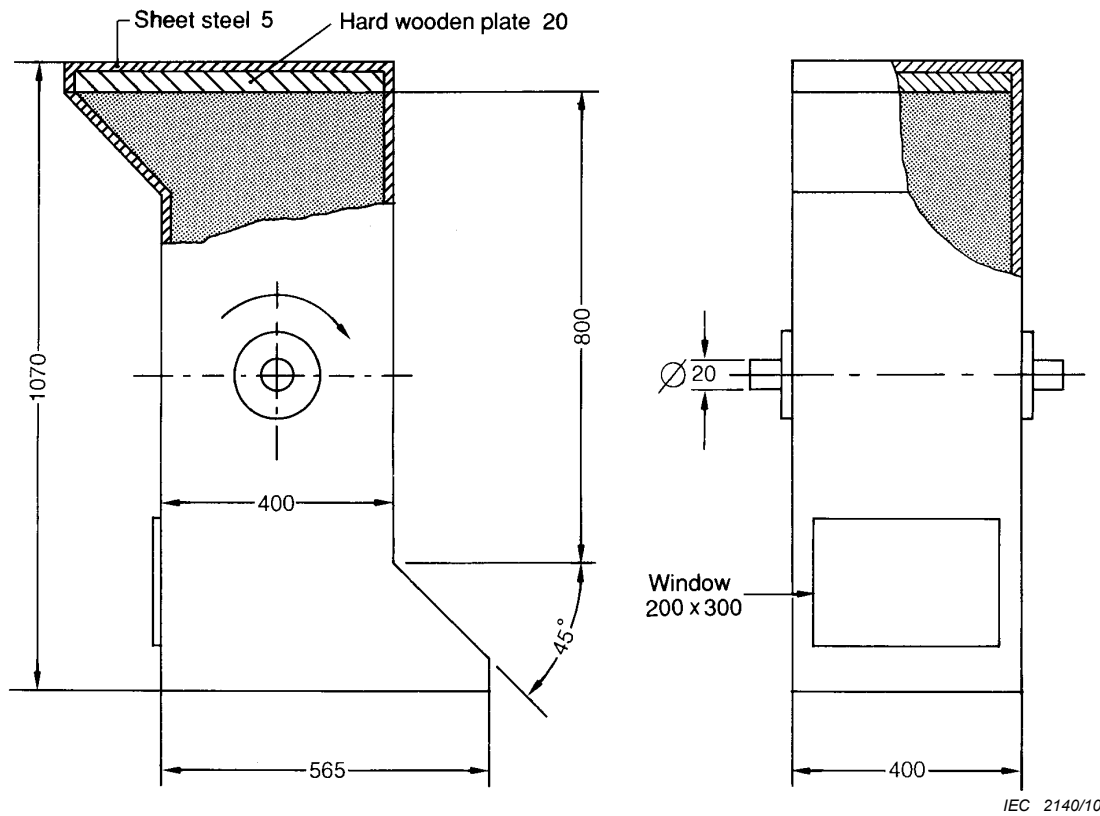

*Dimensions in millimetres*

Drive: geared motor and V-belt drive

Speed of rotation: approximately 5 r/min

A counter, connected to the shaft of the drum, registers the number of falls to which the nozzle has been subjected.

**Figure 28 – Drum for impact test**

When the drum is rotated with a speed of about 5 r/min, the test object drops alternately towards one or the other of the floors of the drum, the height of fall being 80 cm.

### 7.3.11 Device for determination of deformation of hoses and connecting tubes

The device, as shown in Figure 29, consists of a screw press with the support covered by a piece of test carpet, in accordance with 7.2.1.3.2. The force of the screw press is transmitted by a spring to a test plate of polished steel on a cylindrical bearing, the axis of which is perpendicular to that of the test object.

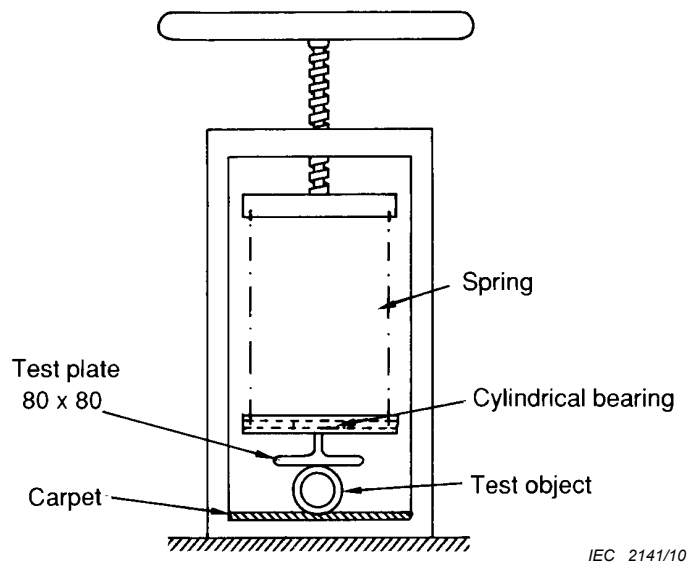

*Dimensions in millimetres*

**Figure 29 – Device for testing deformation of hoses and connecting tubes**

The force applied is indicated on a load indicator and the reduced cross-sectional dimension is measured by a vernier or digital calliper.

### **7.3.12 Mechanical operator**

The principle construction of a mechanical operator is indicated in Figure 30. It consists of a rigid support with a linear drive to carry out double strokes over the test carpet, which has been placed on an incorporated test floor (see 4.2) and is kept in position by hold-downs. As shown in the figure, the equipment may be adapted to measurements of motion resistance by replacing the test floor with the device described in 7.3.9 allowing its wooden plate a sufficient freedom of movement in the direction of the strokes.

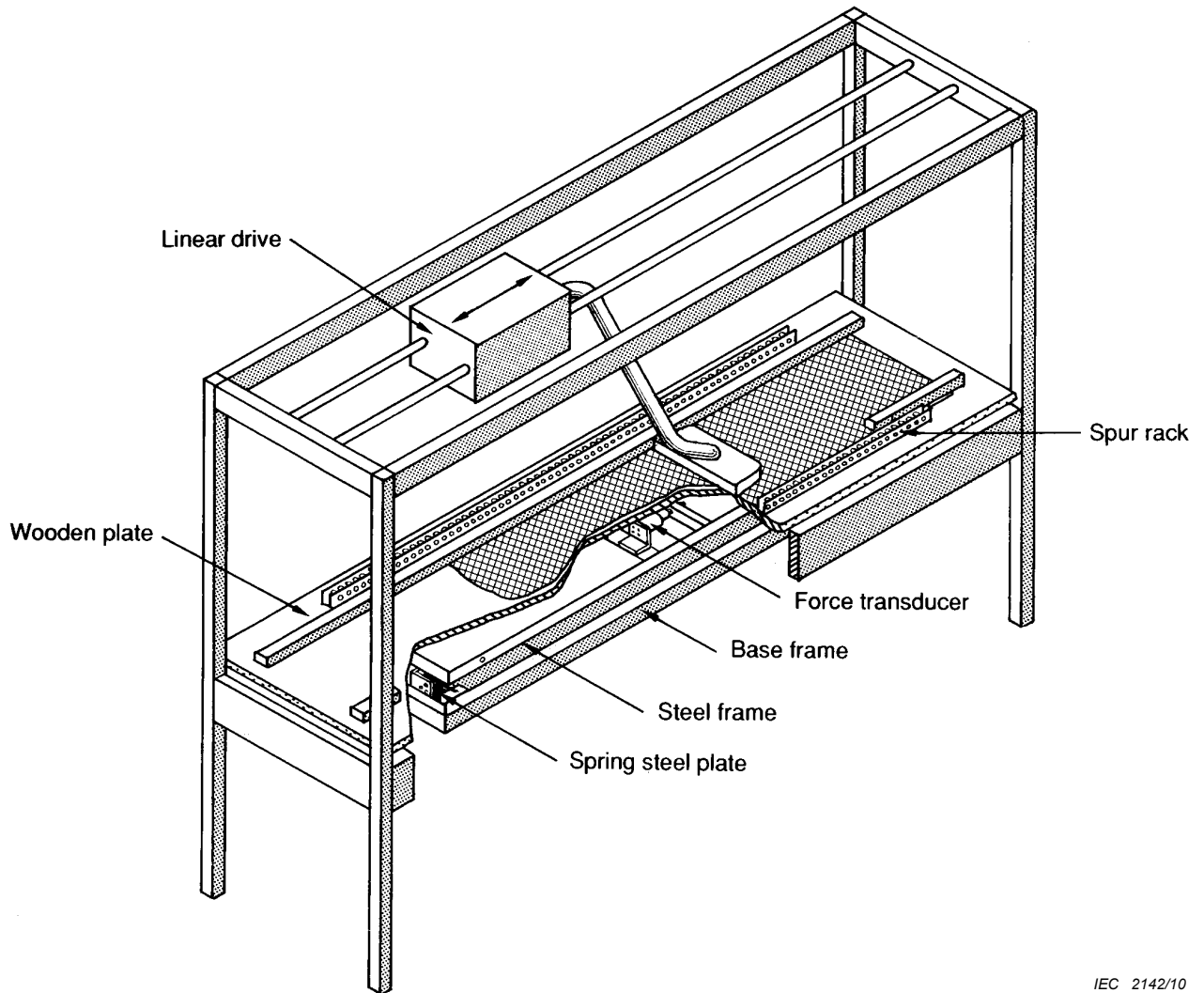

IEC 2142/10

**Figure 30 – Mechanical operator for the measurement of dust removal from carpets and of motion resistance**

The spur racks, which suggest a way to bring about the vibratory action to the dust spreader depicted in Figure 21, have no function in the motion resistance test.

### 7.3.13 Weighing machine

The weighing machine used in connection with tests on dust removal ability and for verification of the pre-cleaning of the test carpet shall have an accuracy of 0,01 g.

The weighing machine used in connection with fibre removal tests shall have an accuracy of 0,05 mg.

### ☐ 7.3.22 Dust collecting box

This box is placed in the suction hose of water filter vacuum cleaner to determine the dust pick up level from carpet and flat hard floor. See Figure Z.6. ☐

## 8 Instructions for use

The manufacturer's instructions for use shall contain information about the use of the appliance and its accessories, if any, and about the cleaning necessary to ensure the proper performance of the appliance.

## **Annex A** (informative)

### **Information on materials**

For the convenience of users of this International Standard, information on supplies of test materials and details of test equipment are available on the IEC website. This information can be accessed via a link that can be found in the abstract of IEC 60312-1 on the IEC web – [www.iec.ch](http://www.iec.ch). This information is given for the convenience of users of this International Standard and does not constitute an endorsement by IEC of the suppliers named.

This information will be continuously updated.



## **Annex B** (informative)

### **Information at the point of sale**

The following information for the consumer should be provided at the point of sale, if applicable:

- a) type of cleaner
- b) voltage/voltage range (V);
- c) frequency (Hz);
- d) power input (W);
- e) cord length (m);
- f) weight (g) (the weight of the vacuum cleaner, attachments and accessories);
- g) dimensions (dimensions concerning the storage of the vacuum cleaner);
- h) noise level;
- i) energy consumption (kWh);
- j) filtration specification.

## Annex C (normative)

### Guidance specification on verified carpets

For test results presented externally, the test carpet shall be one of the following verified carpet types.

#### C.1 Wilton Carpet (7.2.1.3.2)

The typical specification for the Wilton type carpet is as follows:

type	Wilton	
pile composition	wool 8,6/2*2	
method of manufacturing	Wilton fabric	
color	dark, one color	
backing	jute and cotton + latex	
type	cut -pile	
total height	7,5 mm	see also tolerances
pile height	6,4 mm	see also tolerances
total weight/m <sup>2</sup>	2100 g/m <sup>2</sup>	see also tolerances
pile weight/m <sup>2</sup>	1500 g/m <sup>2</sup>	see also tolerances
number of knots/m <sup>2</sup>	96 000 knots/m <sup>2</sup>	see also tolerances
reed	320 r/m	
shots	300 sh/m	
standard width	400 cm	
tolerances	± 5 %	

#### C.2 Category A (7.2.1.3.3)

The typical specification for the Category A carpet (Stratos duraAir) is as follows:

Manufacturing process:	tufting
Surface structure to ISO 2424:	1/10" loop
Composition of the face yarn 71/307/CEE modified:	100% PA, Aquafil-Aqualon
Pile weight:	approximately 645 g/m <sup>2</sup>
Primary cloth to ISO 2424:	100% PP-Non-Woven
Secondary backing to ISO 2424:	textile backing (TR)
Number of tufts/m <sup>2</sup> to ISO 1763:	approximately 230 000/ m <sup>2</sup>
Pile height above the primary cloth to ISO 1766:	approximately 3,5 mm
Surface pile density:	approximately 0,116 g/cm <sup>3</sup>
Total thickness to ISO 1765:	approximately 6,0 mm
Total weight to ISO 8543:	1 700 g/m <sup>2</sup>

### **C.3 Category B (7.2.1.3.4)**

#### **C.3.1 General**

The typical specification for the Category B carpet (cut pile) is as follows (measured at 21 °C ± 1 °C and 65 RH ± 2 % RH):

Construction	Cut pile
Backing	Woven synthetic
Average pile yarn weight	1638 g/m <sup>2</sup>
Total weight	3211 g/m <sup>2</sup>
Tuft length	11,8 mm
Pile density	3731
Stitch rate	3.7 per cm
gauge	1/8

#### **C.3.2 Category C (7.2.1.3.5)**

The typical specification for the Category C carpet (Shag) is as follows (measured at 21 °C ± 1 °C and 65 RH ± 2 % RH):

Construction	Shag
Backing	Woven synthetic
Average pile yarn weight	2339 g/m <sup>2</sup>
Total weight	
Pile hight	28,1 mm
Pile density	2246
Stitch rate	2,6 per cm
gauge	1/8

## Bibliography

IEC 60335-1, *Household and similar electrical appliances – Safety – Part 1: General requirements*

IEC 60335-2-2, *Household and similar electrical appliances – Safety – Part 2: Particular requirements for vacuum cleaners and water suction cleaning appliances*

ISO 5011, *Inlet air cleaning equipment for internal combustion engines and compressors – Performance testing*

ASTM F1977, *Standard Test Method for determining Initial, Fractional, Filtration Efficiency of a Vacuum Cleaner System*

ASTM F2608, *Standard Test Method for determining the change in Room Air Particulate Count as a result of the Vacuum Cleaning process*

---



# British Standards Institution (BSI)

BSI is the national body responsible for preparing British Standards and other standards-related publications, information and services.

BSI is incorporated by Royal Charter. British Standards and other standardization products are published by BSI Standards Limited.

## About us

We bring together business, industry, government, consumers, innovators and others to shape their combined experience and expertise into standards-based solutions.

The knowledge embodied in our standards has been carefully assembled in a dependable format and refined through our open consultation process. Organizations of all sizes and across all sectors choose standards to help them achieve their goals.

## Information on standards

We can provide you with the knowledge that your organization needs to succeed. Find out more about British Standards by visiting our website at [bsigroup.com/standards](http://bsigroup.com/standards) or contacting our Customer Services team or Knowledge Centre.

## Buying standards

You can buy and download PDF versions of BSI publications, including British and adopted European and international standards, through our website at [bsigroup.com/shop](http://bsigroup.com/shop), where hard copies can also be purchased.

If you need international and foreign standards from other Standards Development Organizations, hard copies can be ordered from our Customer Services team.

## Copyright in BSI publications

All the content in BSI publications, including British Standards, is the property of and copyrighted by BSI or some person or entity that owns copyright in the information used (such as the international standardization bodies) and has formally licensed such information to BSI for commercial publication and use.

Save for the provisions below, you may not transfer, share or disseminate any portion of the standard to any other person. You may not adapt, distribute, commercially exploit, or publicly display the standard or any portion thereof in any manner whatsoever without BSI's prior written consent.

## Storing and using standards

Standards purchased in soft copy format:

- A British Standard purchased in soft copy format is licensed to a sole named user for personal or internal company use only.
- The standard may be stored on more than 1 device provided that it is accessible by the sole named user only and that only 1 copy is accessed at any one time.
- A single paper copy may be printed for personal or internal company use only.

Standards purchased in hard copy format:

- A British Standard purchased in hard copy format is for personal or internal company use only.
- It may not be further reproduced – in any format – to create an additional copy. This includes scanning of the document.

If you need more than 1 copy of the document, or if you wish to share the document on an internal network, you can save money by choosing a subscription product (see 'Subscriptions').

## Reproducing extracts

For permission to reproduce content from BSI publications contact the BSI Copyright & Licensing team.

## Subscriptions

Our range of subscription services are designed to make using standards easier for you. For further information on our subscription products go to [bsigroup.com/subscriptions](http://bsigroup.com/subscriptions).

With **British Standards Online (BSOL)** you'll have instant access to over 55,000 British and adopted European and international standards from your desktop. It's available 24/7 and is refreshed daily so you'll always be up to date.

You can keep in touch with standards developments and receive substantial discounts on the purchase price of standards, both in single copy and subscription format, by becoming a **BSI Subscribing Member**.

**PLUS** is an updating service exclusive to BSI Subscribing Members. You will automatically receive the latest hard copy of your standards when they're revised or replaced.

To find out more about becoming a BSI Subscribing Member and the benefits of membership, please visit [bsigroup.com/shop](http://bsigroup.com/shop).

With a **Multi-User Network Licence (MUNL)** you are able to host standards publications on your intranet. Licences can cover as few or as many users as you wish. With updates supplied as soon as they're available, you can be sure your documentation is current. For further information, email [subscriptions@bsigroup.com](mailto:subscriptions@bsigroup.com).

## Revisions

Our British Standards and other publications are updated by amendment or revision.

We continually improve the quality of our products and services to benefit your business. If you find an inaccuracy or ambiguity within a British Standard or other BSI publication please inform the Knowledge Centre.

## Useful Contacts

### Customer Services

**Tel:** +44 345 086 9001

**Email (orders):** [orders@bsigroup.com](mailto:orders@bsigroup.com)

**Email (enquiries):** [cservices@bsigroup.com](mailto:cservices@bsigroup.com)

### Subscriptions

**Tel:** +44 345 086 9001

**Email:** [subscriptions@bsigroup.com](mailto:subscriptions@bsigroup.com)

### Knowledge Centre

**Tel:** +44 20 8996 7004

**Email:** [knowledgecentre@bsigroup.com](mailto:knowledgecentre@bsigroup.com)

### Copyright & Licensing

**Tel:** +44 20 8996 7070

**Email:** [copyright@bsigroup.com](mailto:copyright@bsigroup.com)

### BSI Group Headquarters

389 Chiswick High Road London W4 4AL UK