

Dependability management —

Part 3-3: Application guide — Life cycle costing

The European Standard EN 60300-3-3:2004 has the status of a
British Standard

ICS 21.020

National foreword

This British Standard is the official English language version of EN 60300-3-3:2004. It is identical with IEC 60300-3-3:2004. It supersedes BS 5760-23:1997 which is withdrawn.

The UK participation in its preparation was entrusted to Technical Committee DS/1, Dependability and terotechnology, which has the responsibility to:

- aid enquirers to understand the text;
- present to the responsible international/European committee any enquiries on the interpretation, or proposals for change, and keep the UK interests informed;
- monitor related international and European developments and promulgate them in the UK.

A list of organizations represented on this committee can be obtained on request to its secretary.

Cross-references

The British Standards which implement international or European publications referred to in this document may be found in the *BSI Catalogue* under the section entitled “International Standards Correspondence Index”, or by using the “Search” facility of the *BSI Electronic Catalogue* or of British Standards Online.

This publication does not purport to include all the necessary provisions of a contract. Users are responsible for its correct application.

Compliance with a British Standard does not of itself confer immunity from legal obligations.

Summary of pages

This document comprises a front cover, an inside front cover, the EN title page, pages 2 to 59 and a back cover.

The BSI copyright notice displayed in this document indicates when the document was last issued.

Amendments issued since publication

Amd. No.	Date	Comments

This British Standard was published under the authority of the Standards Policy and Strategy Committee on 3 November 2004

© BSI 3 November 2004

ISBN 0 580 44706 5

EUROPEAN STANDARD

EN 60300-3-3

NORME EUROPÉENNE

EUROPÄISCHE NORM

September 2004

ICS 21.020

English version

**Dependability management
Part 3-3: Application guide –
Life cycle costing
(IEC 60300-3-3:2004)**

Gestion de la sûreté de fonctionnement
Partie 3-3: Guide d'application -
Evaluation du coût de vie
(CEI 60300-3-3:2004)

Zuverlässigkeitsmanagement
Teil 3-3: Anwendungsleitfaden -
Lebenszykluskosten
(IEC 60300-3-3:2004)

This European Standard was approved by CENELEC on 2004-09-01. CENELEC members are bound to comply with the CEN/CENELEC Internal Regulations which stipulate the conditions for giving this European Standard the status of a national standard without any alteration.

Up-to-date lists and bibliographical references concerning such national standards may be obtained on application to the Central Secretariat or to any CENELEC member.

This European Standard exists in three official versions (English, French, German). A version in any other language made by translation under the responsibility of a CENELEC member into its own language and notified to the Central Secretariat has the same status as the official versions.

CENELEC members are the national electrotechnical committees of Austria, Belgium, Cyprus, Czech Republic, Denmark, Estonia, Finland, France, Germany, Greece, Hungary, Iceland, Ireland, Italy, Latvia, Lithuania, Luxembourg, Malta, Netherlands, Norway, Poland, Portugal, Slovakia, Slovenia, Spain, Sweden, Switzerland and United Kingdom.

CENELEC

European Committee for Electrotechnical Standardization
Comité Européen de Normalisation Electrotechnique
Europäisches Komitee für Elektrotechnische Normung

Central Secretariat: rue de Stassart 35, B - 1050 Brussels

Foreword

The text of document 56/942/FDIS, future edition 2 of IEC 60300-3-3, prepared by IEC TC 56, Dependability, was submitted to the IEC-CENELEC parallel vote and was approved by CENELEC as EN 60300-3-3 on 2004-09-01.

The following dates were fixed:

- latest date by which the EN has to be implemented at national level by publication of an identical national standard or by endorsement (dop) 2005-06-01
- latest date by which the national standards conflicting with the EN have to be withdrawn (dow) 2007-09-01

Annex ZA has been added by CENELEC.

Endorsement notice

The text of the International Standard IEC 60300-3-3:2004 was approved by CENELEC as a European Standard without any modification.

CONTENTS

INTRODUCTION.....	5
1 Scope.....	6
2 Normative references	6
3 Terms and definitions	6
4 Life cycle costing.....	7
4.1 Objectives of life cycle costing	7
4.2 Product life cycle phases and LCC	7
4.3 Timing of LCC analysis.....	9
4.4 Dependability and LCC relationship.....	9
4.4.1 General	9
4.4.2 Dependability related costs.....	9
4.4.3 Consequential costs	10
4.5 LCC concept	12
4.5.1 General	12
4.5.2 LCC breakdown into cost elements.....	13
4.5.3 Estimation of cost.....	14
4.5.4 Sensitivity analysis	17
4.5.5 Impact of discounting, inflation and taxation on LCC.....	17
4.6 Life cycle costing process	17
4.6.1 General	17
4.6.2 Life cycle costing plan	18
4.6.3 LCC model selection or development.....	18
4.6.4 LCC model application.....	19
4.6.5 Life cycle costing documentation	19
4.6.6 Review of life cycle costing results	20
4.6.7 Analysis update	20
4.7 Uncertainty and risks.....	20
5 LCC and environmental aspects	21
Annex A (informative) Typical cost-generating activities.....	22
Annex B (informative) LCC calculations and economic factors	25
Annex C (informative) Example of a life cycle cost analysis	28
Annex D (informative) Examples of LCC model development.....	48
Annex E (informative) Example of a product breakdown structure and LCC summary for a railway vehicle	56
Annex ZA (normative) Normative references to international publications with their corresponding European publications	59
Figure 1 – Sample applications of life cycle costing	8
Figure 2 – Typical relationship between dependability and LCC for the operation and maintenance phase.....	10
Figure 3 – Cost element concept	14
Figure 4 – Example of cost elements used in the parametric cost method	16
Figure C.1 – Structure of DCN	29

Figure C.2 – Cost breakdown structure used for the example in Figure C.1	30
Figure C.3 – Definition of cost elements.....	32
Figure C.4 – Comparison of the costs of investment, annual operation and maintenance	40
Figure C.5 – Net present value (10 % discount rate)	46
Figure C.6 – Net present value (5 % discount rate)	47
Figure C.7 – NPV with improved data store reliability (5 % discount rate)	47
Figure D.1 – Hierarchical structure	52
Figure E.1 – Vehicle system product breakdown structure	57
Table C.1 – First indenture level – Data communication network.....	31
Table C.2 – Second indenture level – Communication system.....	31
Table C.3 – Third indenture level – Power supply system	31
Table C.4 – Third indenture level – Main processor	31
Table C.5 – Third indenture level – Fan system	31
Table C.6 – Cost categories.....	32
Table C.7 – Investments in spare replaceable units	34
Table E.1 – Life cycle cost summary by product breakdown structure	58

INTRODUCTION

Products today are required to be reliable. They have to perform their functions safely with no undue impact on the environment and be easily maintainable throughout their useful lives. The decision to purchase is not only influenced by the product's initial cost (acquisition cost) but also by the product's expected operating and maintenance cost over its life (ownership cost) and disposal cost. In order to achieve customer satisfaction, the challenge for suppliers is to design products that meet requirements and are reliable and cost competitive by optimizing acquisition, ownership and disposal costs. This optimization process should ideally start at the product's inception and should be expanded to take into account all the costs that will be incurred throughout its lifetime. All decisions made concerning a product's design and manufacture may affect its performance, safety, reliability, maintainability, maintenance support requirements, etc., and ultimately determine its price and ownership and disposal costs.

Life cycle costing is the process of economic analysis to assess the total cost of acquisition, ownership and disposal of a product. This analysis provides important inputs in the decision-making process in the product design, development, use and disposal. Product suppliers can optimize their designs by evaluation of alternatives and by performing trade-off studies. They can evaluate various operating, maintenance and disposal strategies (to assist product users) to optimize life cycle cost (LCC). Life cycle costing can also be effectively applied to evaluate the costs associated with a specific activity, for example, the effects of different maintenance concepts/approaches, to cover a specific part of a product, or to cover only selected phase or phases of a product's life cycle.

Life cycle costing is most effectively applied in the product's early design phase to optimize the basic design approach. However, it should also be updated and used during the subsequent phases of the life cycle to identify areas of significant cost uncertainty and risk.

The necessity for formal application of the life cycle costing process to a product will normally depend on contractual requirements. However, life cycle costing provides a useful input to any design decision-making process. Therefore, it should be integrated with the design process, to the extent feasible, to optimize product characteristics and costs.

DEPENDABILITY MANAGEMENT –

Part 3-3: Application guide – Life cycle costing

1 Scope

This part of IEC 60300 provides a general introduction to the concept of life cycle costing and covers all applications. Although the life cycle costs consist of many contributing elements, this standard particularly highlights the costs associated with dependability of the product.

This standard is intended for general application by both customers (users) and suppliers of products. It explains the purpose and value of life cycle costing and outlines the general approaches involved. It also identifies typical life cycle cost elements to facilitate project and programme planning.

General guidance is provided for conducting a life cycle cost analysis, including life cycle cost model development. Illustrative examples are provided to explain the concepts.

2 Normative references

The following referenced documents are indispensable for the application of this document. For dated references, only the edition cited applies. For undated references, the latest edition of the referenced document (including any amendments) applies.

IEC 60050-191:1990, *International Electrotechnical Vocabulary (IEV) – Chapter 191: Dependability and quality of service*

IEC 60300-3-12, *Dependability management – Part 3-12: Application guide – Integrated logistic support*

IEC 61703, *Mathematical expressions for reliability, maintainability and maintenance support terms*

IEC 62198, *Project risk management – Application guidelines*

3 Terms and definitions

For the purposes of this document, the terms and definitions given in IEC 60050-191 and IEC 61703, together with the following definitions, apply.

3.1

life cycle

time interval between a product's conception and its disposal

3.2

life cycle costing

process of economic analysis to assess the life cycle cost of a product over its life cycle or a portion thereof

3.3**life cycle cost****LCC**

cumulative cost of a product over its life cycle

3.4**base date**

fixed point in time set as the common cost reference

4 Life cycle costing**4.1 Objectives of life cycle costing**

Life cycle costing is the process of economic analysis to assess the total cost of acquisition, ownership and disposal of a product. It can be applied to the whole life cycle of a product or to parts or combinations of different life cycle phases.

The primary objective of life cycle costing is to provide input to decision making in any or all phases of a product's life cycle.

An important objective in the preparation of LCC models is to identify costs that may have a major impact on the LCC or may be of special interest for that specific application. Equally important is to identify costs that may only influence the LCC to a very small extent.

The more common types of decisions to which the life cycle costing process provides input include, for example:

- evaluation and comparison of alternative design approaches and disposal options technologies;
- assessment of economic viability of projects/products;
- identification of cost contributors and cost effective improvements;
- evaluation and comparison of alternative strategies for product use, operation, test, inspection, maintenance, etc.;
- evaluation and comparison of different approaches for replacement, rehabilitation/life extension or retirement of ageing facilities;
- allocation of available funds among the competing priorities for product development/improvement;
- assessment of product assurance criteria through verification tests and its trade-off;
- long-term financial planning.

Life cycle costing can be used to provide input to integrated logistic support analysis. See IEC 60300-3-12 for detailed information on integrated logistic support analysis.

4.2 Product life cycle phases and LCC

Fundamental to the concept of life cycle costing is a basic understanding of a product life cycle and the activities that are performed during these phases. Also essential is an understanding of the relationship of these activities to the product performance, safety, reliability, maintainability and other characteristics contributing to life cycle costs.

There are six major life cycle phases of a product as follows:

- a) concept and definition;
- b) design and development;
- c) manufacturing;

- d) installation;
- e) operation and maintenance;
- f) disposal.

The appropriate life cycle phases, or parts or combinations of these phases, should be selected to suit the special needs of each specific analysis. In a general way, the total costs incurred during the above phases can also be divided into acquisition cost, ownership cost and disposal cost.

$$LCC = Cost_{\text{acquisition}} + Cost_{\text{ownership}} + Cost_{\text{disposal}}$$

Acquisition costs are generally visible, and can be readily evaluated before the acquisition decision is made and may or may not include installation cost.

The ownership costs, which are often a major component of LCC, in many cases, exceed acquisition costs and are not readily visible. These costs are difficult to predict and may also include the cost associated with installation.

Disposal costs may represent a significant proportion of total LCC. Legislation may require activities during the disposal phase that for major projects, e.g. nuclear power stations, involve a significant expenditure.

Figure 1 shows the life cycle phases of a product, together with some of the topics that should be addressed by a life cycle costing study.

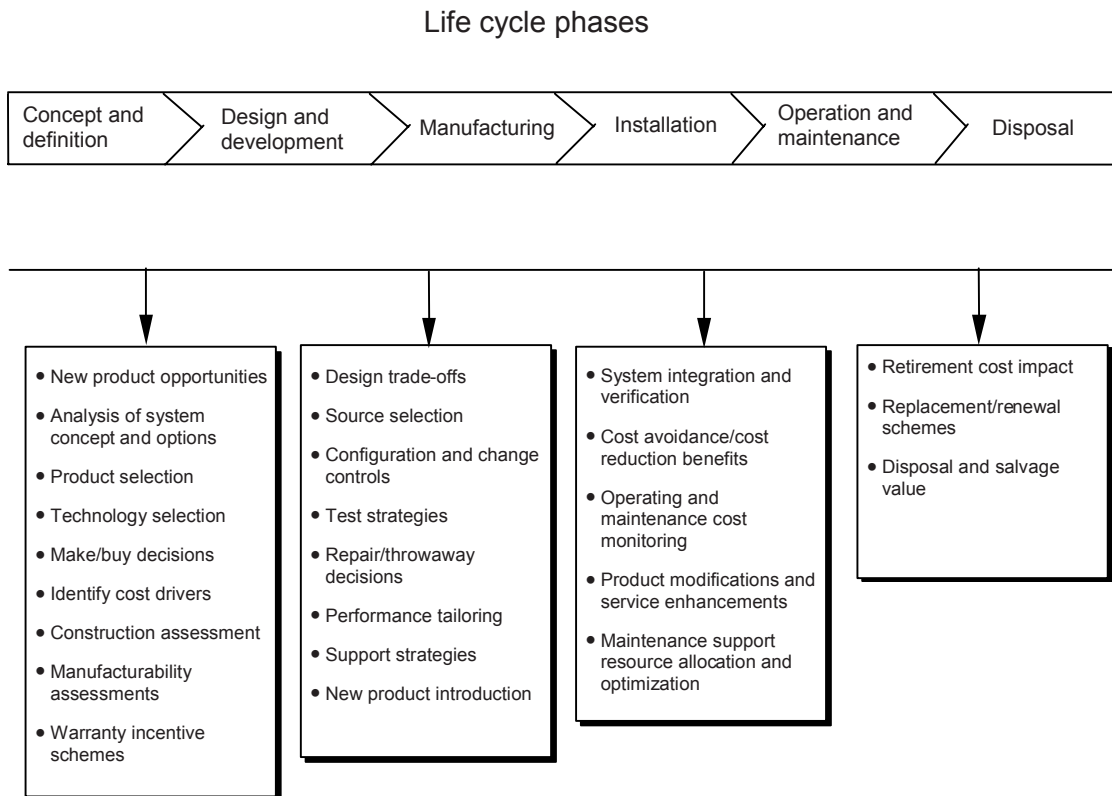

IEC 715/04

Figure 1 – Sample applications of life cycle costing

4.3 Timing of LCC analysis

Early identification of acquisition, ownership and disposal costs enables the decision-maker to balance dependability factors against life cycle costs. Decisions made early in a product's life cycle have a much greater influence on LCC than those made later in a product's life cycle. Experience has shown that by the end of the concept and definition phases, more than half of a product's LCC may be committed by decisions. The opportunity to perform trade-offs becomes increasingly limited as the product advances in its life cycle.

Life cycle costing may address the whole life cycle of a product or only part of it. The life cycle costing should be tailored to suit a particular product/project in order to obtain the maximum benefit from the analysis effort.

4.4 Dependability and LCC relationship

4.4.1 General

Dependability of a product is the collective term used to describe the product's availability performance and its influencing factors, i.e. reliability performance, maintainability performance and maintenance support performance. Performance in all these areas can have a significant impact on the LCC. Higher initial costs may result in improved reliability and/or maintainability, and thus improved availability with resultant lower operating and maintenance costs.

Dependability considerations should be an integral part of the design process and LCC evaluations. These considerations should be critically reviewed when preparing product specifications, and be continually evaluated throughout the design phases in order to optimize product design and the life cycle cost.

4.4.2 Dependability related costs

Costs associated with dependability elements may include the following, as appropriate:

- system recovery cost including corrective maintenance cost;
- preventive maintenance cost;
- consequential cost.

Figure 2 highlights some dependability elements translated into operation and maintenance costs.

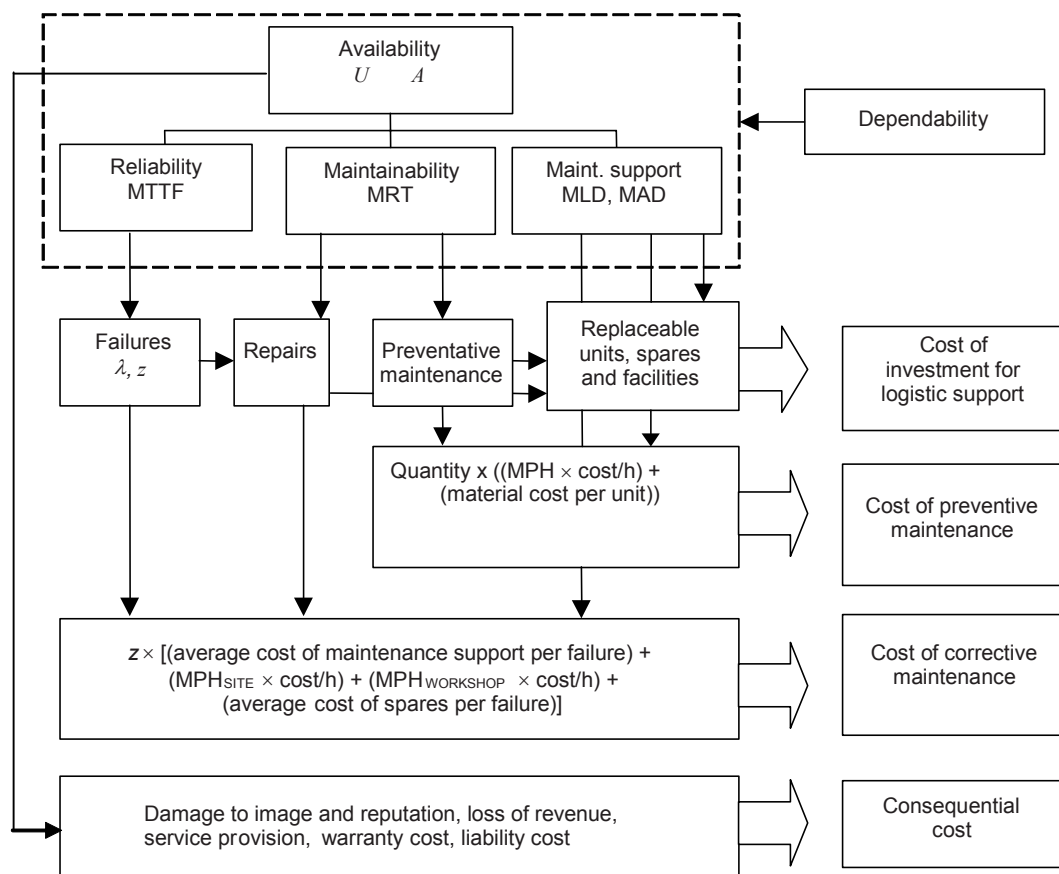

Symbols and abbreviations apply in accordance with IEC 60050(191).

Figure 2 – Typical relationship between dependability and LCC for the operation and maintenance phase

4.4.3 Consequential costs

4.4.3.1 General

When a product or service becomes unavailable, a series of consequential costs may be incurred. These costs may include:

- warranty cost;
- liability cost;
- cost due to loss of revenue;
- costs for providing an alternative service.

In addition, further consequential costs should be identified by applying risk analysis techniques to determine costs of adverse impacts on the company's:

- image,
- reputation,
- prestige,

which in turn may result in loss of clients.

Costs of recovering from, or mitigating against these risks should be included in consequential costs.

In most cases, these costs are difficult to assess, but sometimes it is possible to quantify them. For example, these costs may be estimated based on publicity campaign costs and costs of marketing efforts or compensations in order to retain the clients. Where applicable, these costs should be accounted for.

The unavailability of a product can significantly affect its LCC. Therefore, the availability performance of a product and associated life cycle cost needs to be optimized. With increasing reliability (all other factors held constant), the acquisition costs will generally increase but maintenance and support costs will decrease. The LCC is optimized when the incremental increase in acquisition costs due to reliability improvements equals the incremental savings in maintenance and support costs, and in consequential costs. At a certain point, an optimum product reliability, which corresponds to the lowest life cycle cost, is achieved.

It should be noted that the results of LCC calculations might not match the actual/observed costs. This is because there are many influencing random factors, such as environmental conditions and human errors during operation, which cannot be accurately modelled in the calculations.

Environmental issues, as well as traditional factors such as cost and time, have to be considered in LCC calculations. Therefore, methods have to be used to evaluate and rank environmental consequences of different activities. These evaluations can provide the bases for environmental planning and integrating environmental issues with decision making.

4.4.3.2 Warranty costs

Warranties provide protection to the customers, insulating them from the cost of correcting product failures, in particular during the early stages of product operations. The cost of warranties is usually borne by the suppliers, and may be affected by reliability, maintainability and maintenance support characteristics of the product. Suppliers can exercise significant control over these characteristics during design and development, and manufacturing phases thus influencing the warranty costs.

Warranties usually apply for a limited period of time, and a number of conditions generally apply. Warranties rarely include protection against consequential costs incurred by the customer due to product unavailability.

Warranties may be supplemented or replaced by service contracts whereby the supplier performs, in addition to any arrangements made by the customer, all preventive and corrective maintenance for a fixed period of time that can be renewed for any period up to the whole product lifetime. In the latter case, the suppliers are motivated to build an optimum level of reliability and maintainability into their product, usually at higher acquisition costs.

4.4.3.3 Liability costs

A liability will arise where, for example, a supplier fails to comply with his legal obligations. The cost of compensating for a breach of the law needs to be considered as part of the LCC. This is especially important in the case of products that have a high potential to cause human injury and/or environmental damage. Liability costs are also important for new products for which risks involved may not be fully apparent and/or well understood. Where required, a risk analysis, together with past experience and expert judgement, may be used to provide an estimate of these costs. For guidance on risk analysis, see IEC 62198.

4.5 LCC concept

4.5.1 General

An LCC model, like any other model, is a simplified representation of the real world. It extracts the salient features and aspects of the product and translates them into cost estimating relationships. In order for the model to be realistic, it should:

- a) represent the characteristics of the product being analysed, including its intended use environment, maintenance concept, operating and maintenance support scenarios as well as any constraints or limitations;
- b) be comprehensive in order to include and highlight all factors that are relevant to LCC;
- c) be simple enough to be easily understood and allow for its timely use in decision making, and future update and modification;
- d) be designed in such a way as to allow for the evaluation of specific elements of LCC independent from other elements.

A simple LCC model is basically an accounting structure that contains mathematical expressions for the estimation of cost associated with each of the cost elements constituting the LCC. Examples are given in Annex D.

In some cases, a model may need to be specifically developed for the problem under study, while for some other cases commercially available models may be used. Each LCC model has its own flexibility and application. Knowledge of the contents and the conditions under which they apply are important in order to assure adequacy of their use. Before selecting a model, the amount of information needed should be identified together with the results expected from using the model. Someone familiar with the details of the model is needed to review it so as to determine the applicability of all cost factors, empirical relationships, elements and other constants and variables in the model. Therefore, before using any existing LCC model, it should be suitably validated for the life cycle costing study under consideration. To do this, the cost factors and other parameters from a known example, along with the operational scenario, should be used to assess the extent to which the model provides realistic results.

Many products are designed to have a very long life, for example buildings or power stations. For such products, a number of costs, for instance for functional changes or product enhancement, will occur at intervals during the life of the product and techniques to deal with these should be incorporated in the model.

LCC modelling includes:

- cost breakdown structure,
- product/work breakdown structure,
- selection of cost categories,
- selection of cost elements,
- estimation of costs,
- presentation of results.

When applicable it may also include:

- environmental and safety aspects,
- uncertainties and risks,
- sensitivity analysis to identify cost drivers.

The cost breakdown structure presents a breakdown of costs incurred over the major phases (or phases of interest) of the life cycle of a product. Annex C includes examples of presentation of costs related to cost breakdown structure.

The product/work breakdown structure is composed of a detailed breakdown of hardware, services and data identifying all major tasks and supporting work packages. Annex E gives an example of a product breakdown structure and LCC summary for a railway vehicle.

Detailed expressions for costs for the different phases can be developed separately. The cost elements, factors, etc. should have unique identities. In a situation where analyses cover several phases, the identities of cost elements, factors, etc. should be unique in the total LCC model. It is normally an advantage to maintain the product/work breakdown structure unvaried for the particular study.

4.5.2 LCC breakdown into cost elements

In order to estimate the total life cycle cost, it is necessary to break down the total LCC into its constituent cost elements. These cost elements should be individually identified so that they can be distinctly defined and estimated. The identification of the elements and their corresponding scope should be based on the purpose and scope of the LCC study.

The cost element is the link between cost categories and the product/work breakdown structure. The selection of cost elements should be related to the complexity of the product, as well as to the cost categories of interest in accordance with the required cost breakdown structure. See the example in Annex C.

One approach often used to identify the required cost elements involves the breakdown of the product to lower indenture levels, cost categories and life cycle phases. This approach can best be illustrated by the use of a three-dimensional matrix shown in Figure 3. This matrix involves identification of the following aspects of the product:

- breakdown of the product to lower indenture levels (i.e. the product/work breakdown structure);
- the time in the life cycle when the work/activity is to be carried out (i.e. the life cycle phases);
- the cost category of applicable resources such as labour, materials, fuel/energy, overhead, transportation/travel (i.e. the cost categories).

This kind of approach has the advantage of being systematic and orderly, thus giving a high level of confidence that all cost elements have been included.

Annex A identifies typical activities for which the costs should be addressed.

An example of a product breakdown structure and LCC summary for a railway vehicle is presented in Annex E.

Costs associated with LCC elements may be further allocated between recurring and non-recurring costs so that the total of all recurring and non-recurring costs equals LCC. LCC elements may also be estimated in terms of fixed and variable costs. The latter costs, for example, will vary with the number of copies of the product to be produced and put into use.

To facilitate control and decision making, and to support the life cycle cost process, the costs information should be collected and reported to be consistent with the defined LCC breakdown structure. A database should be established and maintained to capture results of previous LCC studies in order to serve as a source of experience feedback.

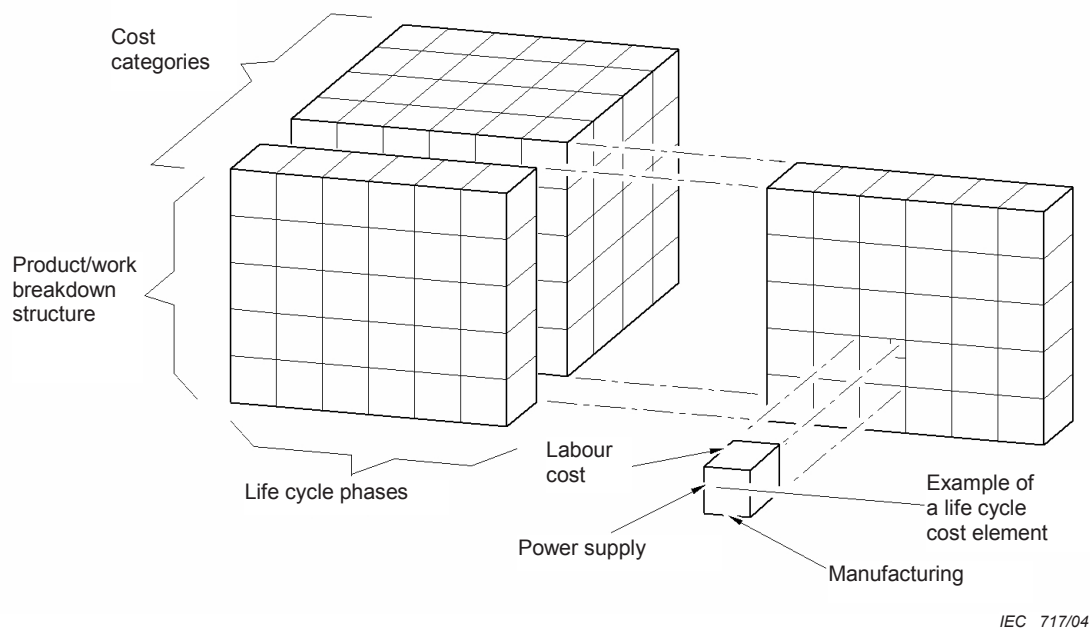

Figure 3 – Cost element concept

4.5.3 Estimation of cost

4.5.3.1 General

Examples of methods that may be used to estimate the parameters of a cost element include:

- engineering cost method;
- analogous cost method;
- parametric cost method.

Examples of application of each method are given below.

When carrying out life cycle costing analysis for a certain product, one or more of these methods, or other methods, may be used as appropriate.

In order to reduce different types of uncertainties involved in the analyses, it should be possible to perform sensitivity analyses, for example by introducing minimum and maximum values to the parameters of the model into the cost estimation equations.

4.5.3.2 Engineering cost method

When using the engineering cost method, the cost attributes for the particular cost elements are directly estimated by examining the product component by component or part by part. Often, standard established cost factors, e.g. the current engineering and manufacturing estimates, are used to develop the cost of each element and its relationship to other elements. Older estimates available may be updated to the present time by the use of appropriate factors, e.g. annual discounting and escalation factors.

The engineering cost method can be illustrated by the following example concerning the cost related to a recurring cost element:

The labour cost for the manufacture of a power supply is to be estimated. The following information is given:

Product: power supply
 Life cycle phase: manufacturing phase
 Cost category: labour cost.

According to detailed assessment of manufacturing steps provided by the manufacturing department, the time consumption for the production of one unit of the particular power supply is 38,80 person hours. Suppose the labour cost is currency unit (CU) 54,50/person hours. The total labour cost for the production of one unit is then $38,80 \times 54,50 = \text{CU } 2\,114,60$.

4.5.3.3 Analogous cost method

In this method, cost estimations based on experience from a similar product or technology are used. Historical data, updated to reflect cost escalation, effects of technology advances, etc. are utilized. This technique may be one of the least complex and least time-consuming methods. It is easily applied to components of the product for which there is some experience and actual data.

The analogous cost method can be illustrated by the following example where an estimate of the cost for parts and materials for a power supply, using experience from an older power unit, is used.

The following information is given:

Product: power supply
 Life cycle phase: manufacturing phase
 Cost category: parts and materials.

For a somewhat less complex power supply produced 4 years ago, the cost for parts and materials was CU 220. Overall cost escalation over 4 years is taken to be 5 %.

The cost for additional parts will be about CU 50.

Therefore, cost for parts and materials for the new power supply unit is estimated to be

$$\begin{aligned} &\text{Cost of parts and material for the old unit } (1+0,05) + \text{cost for additional parts} = \\ &= 220 \times 1,05 + 50 = \text{CU } 281. \end{aligned}$$

4.5.3.4 Parametric cost method

The parametric cost method uses parameters and variables to develop cost estimating relationships. The method might be used differently in other areas.

The relationships are usually in the form of equations where, for example, person hours are converted into costs.

An example of the parametric cost method used for a calculation of active corrective maintenance cost for a subsystem P_{14} , is given in Figure 4.

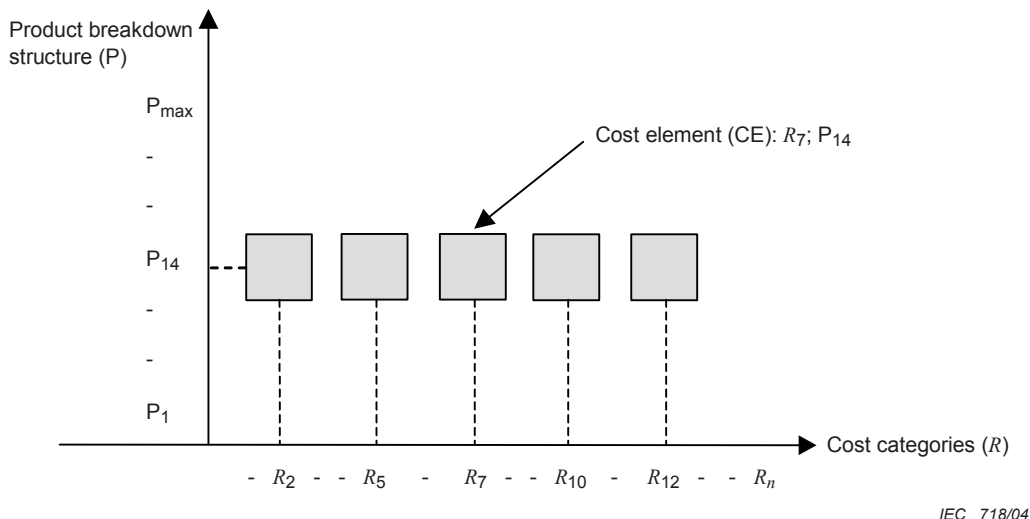

Figure 4 – Example of cost elements used in the parametric cost method

In Figure 4

R_2 is the investment cost in test equipment, workshop (non-recurring);

R_5 is the investment cost in spares, workshop (non-recurring);

R_7 is the labour cost, site (recurring);

R_{10} is the labour cost, workshop (recurring);

R_{12} is the spares consumption cost, workshop (recurring);

P_{14} is subsystem P_{14} .

Cost of active corrective maintenance for subsystem P_{14} for a 10 year period =

$$\text{Cost}(R_2; P_{14}) + \text{Cost}(R_5; P_{14}) + \{\text{Cost}(R_7; P_{14}) + \text{Cost}(R_{10}; P_{14}) + \text{Cost}(R_{12}; P_{14})\} \times 10$$

(ignoring the effects of inflation, etc.)

NOTE Active corrective maintenance time is defined in IEC 60050(191), see definition 191-08-07 and Figure 191-10.

where, for example, the cost related to element ($R_7; P_{14}$) is calculated as follows:

$\text{Cost}(R_7; P_{14})$ is the labour cost, active corrective maintenance at site for sub-system P_{14}

$$\text{Cost}(R_7; P_{14}) = QP_{14} \times ZP_{14} \times C_L \times n \times \text{MRT cost/year}$$

where

QP_{14} is the quantity or number of items, in this example $QP_{14} = 1$;

ZP_{14} is the expected number of failures/year for subsystem P_{14} ;

C_L is the labour cost/hour;

n is the number of persons required to carry out the repair;

MRT is the mean repair time in h/action.

Assume:

$$QP_{14} = \text{one item /system}$$

$$ZP_{14} = 0,3 \text{ failures/year}$$

$$C_L = \text{CU } 50/\text{hour}$$

$$n = \text{one person}$$

MRT = 2,4 h/action.

Then

$$\text{Cost}(R_7; P_{14}) = 1 \times 0,3 \times 50 \times 1 \times 2,4 = \text{CU } 36/\text{year}.$$

To calculate the labour cost over 10 years, the result should be multiplied by 10 (ignoring the effects of inflation, etc.).

If different factors, for instance inflation or discounting, have to be taken into account, this could be included in the estimation of cost related to each element or at a higher cost element level in the LCC model.

Cost(R_{10} ; P_{14}), etc. are calculated in a similar way.

4.5.4 Sensitivity analysis

In order to identify significant cost contributors, sensitivity analyses should be performed. Data may be varied to establish their impact on the total LCC or part of it.

To facilitate the sensitivity analysis, it is important that the LCC model is developed in such a manner that, when a common parameter, for instance person hour cost, is varied, this is automatically reflected wherever this parameter is used.

It may be desirable to use minimum or maximum values of certain data or even a distribution. The LCC model in that case should be developed to meet these needs.

4.5.5 Impact of discounting, inflation and taxation on LCC

Several factors complicate the life cycle costing process; for example, the real value of money changes constantly and factors such as opportunity costs, inflation and taxation may need to be taken into account.

Annex B introduces these concepts and briefly indicates the methods that may be used to take account of them.

4.6 Life cycle costing process

4.6.1 General

The life cycle costing process involves identification and evaluation of the costs associated with acquisition, ownership and disposal of a product during its life cycle. In order to produce results which can be usefully and correctly employed, any life cycle costing analysis should be conducted in a structured and well-documented manner using the following steps:

- a) life cycle costing plan (including definition of life cycle costing objectives);
- b) LCC model selection or development;
- c) LCC model application;
- d) life cycle costing documentation;
- e) review of life cycle costing results;
- f) analysis update.

The above steps may be carried out in an iterative fashion if efforts at any stage indicate a need to revisit and modify work accomplished at earlier stages. Assumptions made at each step should be rigorously documented to facilitate such iterations and to aid interpretation of the results of the analysis.

Life cycle costing is a multidisciplinary activity. The analysts should be familiar with the basic principles of life cycle costing (including typical cost elements, sources of cost data and financial principles), and should have a clear understanding of the methods of assessing the uncertainties associated with cost estimation. Depending upon the scope of the analysis, it will be important to obtain cost inputs from individuals who are familiar with all phases of the product life cycle. This may include representatives of both the supplier(s) and the customer(s).

4.6.2 Life cycle costing plan

Life cycle costing should begin with the development of a plan which addresses the purpose and scope of the analysis. The plan should address the following elements:

- a) Define the analysis objectives in terms of the outputs that should be provided by the analysis and the decisions as to which outputs will be used to support the analysis. Typical objectives include:
 - determination of the LCC for a product in order to support planning, contracting, budgeting or similar needs;
 - evaluation of the impact of alternative courses of action (such as design approaches, product acquisition or support policies or alternative technologies) on the LCC of a product; or
 - identification of cost elements which are major contributors to the LCC of a product in order to focus design, development, acquisition or product support efforts.
- b) Define the scope of the analysis in terms of the product(s) being studied, the time period (life cycle phases) to be considered, the operating environment and maintenance support scenario to be employed.
- c) Identify any underlying conditions, assumptions, limitations and constraints (such as minimum product performance or availability requirements, or maximum capital cost limitations) which might restrict the range of acceptable options to be evaluated.
- d) Identify alternative courses of action to be evaluated (if it is a part of the analysis objective). The list of proposed alternatives may be refined as new options are identified, or as existing options are found to violate the problem constraints.
- e) Provide an estimate of resources required and a reporting schedule for the analysis, to ensure that the analysis results will be available in a timely manner to support the decision-making processes for which they are required.

The analysis plan should be documented at the beginning of the LCC analysis process to provide a focus for the rest of the work. The plan should be reviewed by the intended users of the analysis results, both from a customer and a supplier perspective, to ensure that their needs have been correctly interpreted and clearly addressed.

4.6.3 LCC model selection or development

LCC models of sufficient detail to meet the objectives of the analysis should be selected or developed taking into account the availability of data and the following factors:

- a) degree of selectivity required to discriminate between options;
- b) degree of sensitivity required to provide the necessary output accuracy;
- c) time available for performing and reporting the life cycle costing analysis.

4.6.4 LCC model application

Life cycle costing should include the following steps:

- a) Obtain data for all of the basic cost elements in the LCC model for all product options, subsystems and support option combinations.
- b) Perform LCC analysis of product operating scenarios defined in the analysis plan.
- c) Report analyses with a view to identifying optimum support scenarios.
- d) Examine LCC model inputs and outputs to determine the cost elements that have the most significant impact on the analyses.
- e) Quantify any differences in product performance, availability or other relevant constraints between any options being studied, unless these differences are directly reflected in the LCC model outputs.
- f) Categorize and summarize LCC model outputs according to any logical groupings, for example, fixed or variable costs, recurring or non-recurring costs, acquisition, ownership or disposal costs, direct or indirect costs which may be relevant to users of the analysis results.
- g) Conduct sensitivity analyses to examine the impact of assumptions and cost element uncertainties on LCC model results. Particular attention should be focused on major cost contributors and assumptions related to product usage and assumption related to the time value of money.
- h) Review LCC outputs against the objectives defined in the analysis plan to ensure that all goals have been fulfilled and that sufficient information has been provided to support the required decision. If the objectives have not been met, additional evaluations and/or modifications to the LCC model may be required.

The analyses, including all assumptions, should be documented to ensure that the results can be verified and readily replicated by another evaluator.

4.6.5 Life cycle costing documentation

The results of the life cycle costing should be documented in a report that allows users to clearly understand both the outcomes and the implications of the analysis, including the limitations and uncertainties associated with the results. The report should contain the following:

- a) *Executive summary* – a brief synopsis of the objectives, results, conclusions and recommendations of the analysis. This summary is intended to provide an overview of the analysis to the decision-makers, users and other interested parties.
- b) *Purpose and scope* – a statement of the analysis objective, product description, including a definition of intended product use environment, operating and support scenarios; assumptions, constraints, and alternative courses of action considered in the analysis, as discussed in 4.6.2. Since this information is included in the analysis plan, the plan may be included in the documentation as a reference.
- c) *LCC model description* – a summary of the LCC model, including relevant assumptions, a depiction of the LCC breakdown structure, an explanation of the cost elements and the way in which they were estimated, and a description of the way in which cost elements were integrated.
- d) *LCC model application* – a presentation of the LCC model results, including the identification of significant cost contributors, the results of sensitivity analyses and the output from any other related analysis activities, as discussed in 4.6.4. Annex F illustrates the use of a spreadsheet for LCC analyses and for presentation of the results.
- e) *Discussion* – a thorough discussion on and interpretation of the analysis results, including any uncertainties associated with the results, and of any other issues that will assist the decision-makers and/or users in understanding and using the results.
- f) *Conclusions and recommendations* – a presentation of conclusions related to the objectives of the analysis, and a list of recommendations regarding the decisions which are to be based on the analysis results, as well as an identification of any need for further work or revision of the analysis.

4.6.6 Review of life cycle costing results

A formal, possibly independent, review of the analysis may be required to confirm the correctness and integrity of results. The following elements should be addressed:

- a) review of the objectives and scope of the analysis to ensure that they have been appropriately stated and interpreted;
- b) review of the model (including cost element definitions and assumptions) to ensure that it is adequate for the purpose of the analysis;
- c) review of the application to ensure that the inputs have been accurately established, that the model has been used correctly, that the results (including those of sensitivity analysis) have been adequately evaluated and discussed and that the objectives of the analysis have been achieved;
- d) review of all assumptions made during the analysis to ensure that they are reasonable, and that they have been adequately documented.

4.6.7 Analysis update

It is advantageous in many life cycle costing studies to keep the LCC model current so that it can be exercised throughout the life cycle of the product. For example, it may be desirable to update the analysis results initially based on preliminary or estimated data with more detailed data as they become available later in the product life cycle. Maintaining and updating the LCC model may involve modifications to the LCC breakdown structure and changes to cost estimating methods as additional information sources become available, and alterations in assumptions embodied in the model.

The updated analysis should be documented and reviewed to the same extent as the original.

4.7 Uncertainty and risks

LCC is an estimate of the cost of acquisition, ownership and disposal of a product over its life cycle. As emphasized throughout this standard, the confidence in the results of life cycle costing depends on the availability and use of the relevant information, the assumptions made in the LCC model and the input data used in the analysis.

Factors such as lack of information at the beginning of the project, introduction of new technology or a new product, use of optimistic estimates in order to justify the project, use of unattainable schedules, lengthy research and development projects with unpredictable results, undue optimism/pessimism, etc. all contribute to uncertainty and risk. Elements such as predicted inflation rates, labour, material and overhead costs to be incurred over a long period of time in the future can also cause considerable uncertainty in the results of life cycle cost analysis. Therefore, erroneous conclusions may be drawn and wrong decisions made due to the use of incorrect models, incorrect data and/or the omission of some cost significant items.

The uncertainty and risk are further compounded by the fact that many important factors relevant to a decision may not be quantifiable in terms of costs. Value judgements based on experience should be used to account for such factors. Such value judgements are generally qualitative. In practice, decision-making based on life cycle cost of a product often involves a combination of quantitative and qualitative considerations. The quantitative results provide a baseline reference, whereas qualitative assessments provide reinforcement for further support of the recommendations and decisions.

In order to reduce the risks involved in quantitative assessment, sensitivity analyses should be performed, with a range of potential values considered primarily for parameters of significant cost contributors and other important variables. The results of these sensitivity analyses should be assessed in detail and the possible range of variation in resultant life cycle costs determined. The degree of verification of the analysis should be commensurate with the seriousness of the impact of analysis results and the value of the decision.

For example, for supporting decisions that require significant expenditures, the analysis may require verification by independent experienced personnel.

It is important that the specific risks involved and the possible range of variation of life cycle costing results are brought to the attention of the decision-maker for consideration.

Any decisions made about a product's design and manufacture can affect its performance, safety, reliability, maintainability, maintenance support and, ultimately, its acquisition, ownership and disposal costs. There are many factors beyond the designer's control that may introduce cost uncertainties with attendant economical consequences.

These may include uncertainties related to the following:

- a) commercial and legal relationship between the owner and other organizations;
- b) economic circumstances of the organization, country, e.g. exchange rates;
- c) political circumstances including legislative changes and factors;
- d) technology and technical issues such as safety and environmental impact;
- e) natural events, human behaviour, etc.;
- f) unavailability due to system failures;
- g) not using latest available data;
- h) inadequate data traceability.

Systematic methods should be used to identify and evaluate uncertainties and risks associated with any product, activity, function or process. This should be done in a way that will enable the organization to minimize losses (or maximize gains) and to quantify the probable consequences. As part of this, risk analyses should be carried out.

One objective of uncertainty and risk analyses is to separate the minor acceptable risks from the major risks and to estimate the consequences of each risk. The consequences may be expressed in terms of technical and other criteria including costs.

To get a better overview of the total costs involved, uncertainty and risk analyses may be performed as part of life cycle cost analyses. For example, the amount it will cost the customer in loss of receipts, in loss of production, in fines, etc. if the actual number of failures is twice as high as the specified value.

The uncertainty and risk cost elements should be included in the cost of acquisition, cost of ownership and cost of disposal. This may be accomplished either by including the costs in suitable cost elements or at a higher level in the LCC model.

5 LCC and environmental aspects

Society is becoming increasingly concerned about the environmental impact of products and services. All decisions made about a product's design, manufacture, use, etc., including the environmental impact, may affect the price, ownership and disposal costs.

If the costs of the actions that have to be taken to fulfil environmental regulations are included in the LCC studies, this will provide important inputs into the decision-making process for product design, development and use.

Suppliers and users of products and services should pay attention to environmental consequences of production, operation, maintenance and logistics activities. The cost advantages of cheap but harmful activities have to be carefully considered.

Annex A (informative)

Typical cost-generating activities

A.1 General

Each phase of the life cycle includes activities that contribute to the costs for that phase. This annex lists some typical activities for each phase for which the costs should be identified. Costs for additional activities should be identified, as appropriate.

Design, development, manufacturing, installation, operation, maintenance and disposal of hardware and software include activities that contribute to the LCC. The costs associated with the activities may be grouped, based on the type of resource used.

A.2 Typical costs in the product life cycle phases

A.2.1 Concept and definition

Concept and definition costs are attributed to various activities conducted to ensure the feasibility of the product under consideration. These typically include costs for

- a) market research,
- b) project management,
- c) product concept and design analysis,
- d) preparation of a requirement specification of the product.

A.2.2 Design and development

Design and development costs are attributed to meeting the product requirements specification and providing proof of compliance. These typically include costs for

- a) project management,
- b) design engineering, including reliability, maintainability and environmental protection activities,
- c) design documentation,
- d) prototype fabrication,
- e) software development,
- f) testing and evaluation,
- g) producibility engineering and planning,
- h) vendor selection,
- i) demonstration and validation,
- j) quality management.

A.2.3 Manufacturing and installation

Manufacturing and installation costs are quantified in terms of making the necessary number of copies of the product or providing the specified service on a continuous basis. The activities (costs) in this phase are subdivided between those that are non-recurring and those that recur with each product or service provided. These typically include costs for

- a) non-recurring activities/costs
 - 1) industrial engineering and operations analysis,
 - 2) construction of facilities,
 - 3) production tooling and test equipment,
 - 4) special support and test equipment,
 - 5) initial spares and repair kits,
 - 6) initial training,
 - 7) documentation,
 - 8) software,
 - 9) type-approval testing (qualification testing);
- b) recurring activities/costs
 - 1) production management and engineering,
 - 2) facility maintenance,
 - 3) fabrication (labour, materials, etc.),
 - 4) quality control and inspection,
 - 5) assembly, installation and checkout,
 - 6) packaging, storage, shipping and transportation,
 - 7) ongoing training.

A.2.4 Operation and maintenance

The costs of operation, maintenance and supply support of products and support equipment are incurred throughout the expected life of the system/product. These costs typically include the following:

- a) Costs associated with operation
 - non-recurring costs, e.g. costs for initial training of staff, documentation, initial spares, equipment, facilities and special tools;
 - recurring costs, e.g. costs for labour, consumables, power, on-going training and upgrading.
- b) Costs associated with preventive maintenance
 - non-recurring costs, e.g. costs for acquisition of test equipment and tools, initial spares and consumables, and initial training of staff and initial documentation and facilities;
 - recurring costs, e.g. costs for labour, spares, consumables, on-going training and documentation;
 - replacement of parts with limited lifetime (may be recurring or non-recurring).
- c) Costs associated with corrective maintenance
 - non-recurring costs, e.g. costs for test equipment, tools, initial spares, initial training of staff, initial documentation and facilities;
 - recurring costs, e.g. costs for labour, spares and consumables, on-going training and documentation;
 - consequential cost due to loss of production or capability including costs for compensation and loss of income.

Indirect costs that may be significant over long life cycles may also be included here.

A.2.5 Disposal

This phase includes the costs of decommissioning and disposal of older versions of the products. In some service industries, such as the chemical and nuclear industries, the disposal of products can become a significant cost factor. In some countries, environmental legislation is mandating re-cycling of automobiles and electrical equipment. The costs of a product's disposal typically include costs for

- a) system shutdown,
- b) decommissioning,
- c) disassembly and removal,
- d) recycling or safe disposal.

Annex B (informative)

LCC calculations and economic factors

B.1 Opportunity costs, discounting, inflation and taxation

B.1.1 General

The effects of discounting, escalating, opportunity costs, inflation, taxation and exchange rate are referred to in 4.5.3. In this annex, these and other factors and also methods that may be used to take them into account are discussed in more detail.

B.1.2 Opportunity costs

In order to improve a product, it is often necessary to provide additional resources early in the life cycle. Thus, to achieve improved dependability and its consequent benefits, it may be necessary to provide extra resources, such as prototypes and test facilities, in the early stages of the project life cycle. However, it is important to realize that these resources represent funds that could, at least in theory, have been invested to earn a return on capital. The "opportunity" to earn this return is lost by the investment made to improve dependability. The lost return is known as an opportunity cost. The life cycle cost analysis should take account of the lost opportunity cost when considering the benefits of improved dependability or other similar improvements.

B.1.3 Inflation

Due to the difficulties of accurately predicting inflation, it is usual for life cycle cost analysis to be prepared at "constant prices". Sometimes, however, for example in the case of a short life cycle project, it may be possible to predict or agree on a rate of inflation to be included in the analysis.

It is important to ensure that all cost elements and their dependencies that are affected by inflation are fully addressed, and that they are addressed only once (no "double counting").

B.1.4 Taxation

Taxes and subsidies (including grants and tax expenditures) can affect relative prices. Market prices that include them may, for this and other reasons, not accurately reflect opportunity cost or benefit. In life cycle cost analysis, the adjustment of market prices for taxation is appropriate only where the adjustment may make a material difference. This is a matter for case-by-case judgement, but it may be important to adjust for differences between options in the incidence of tax arising from different contractual arrangements, such as in-house supply versus buying-in, or lease versus purchase.

It is usually desirable to exclude most indirect taxes. "Value added" type taxes in particular should be examined to determine whether or not their inclusion is relevant to the analysis. Value added type taxes should be deducted from the market prices of inputs and outputs and thus excluded from the cost calculations. No such adjustment should be made for direct taxes, such as income and corporation taxes, nor for import tariffs or property taxes. Direct taxes, import tariffs and rates should normally be treated like any other costs and included in the normal way.

B.1.5 Exchange rate

The exchange rate is the price at which one currency is exchanged for another currency. This rate will change depending on supply and demand conditions for the relevant currencies in the market. The exchange rate should be considered when products or services are bought from, or sold to, different countries and in different currencies. The terms of the contract may define where the risk associated with exchange fluctuation lies.

B.2 Application of financial evaluation techniques

B.2.1 General

Certain financial evaluation techniques can usefully be applied to life cycle costing. It is, therefore, important that their concepts are fully understood before they are applied.

B.2.2 Discounted cash flow (DCF)

The discounting of cash flows is a fundamental principle that is applied to all modern methods of investment appraisal. The purpose of DCF analysis is to determine the net present value (NPV) of different future cost flow streams.

B.2.3 Internal rate of return (IRR)

Internal rate of return may be used in an investment appraisal to determine whether a prospective investment is viable. If the calculated IRR is greater than an investor's required rate of return, then the investment opportunity is deemed to be profitable.

The IRR is a special case of DCF analysis, where the percentage return of profit on the investment is calculated based upon a net present value of zero. This implies a "break-even" case, whereby the discounted future cash flows balance each other out, providing a minimum rate that has to be met or exceeded. If, for example, a company requires a return of 12 % for a new project to be worth investing in, then the calculated IRR has to be at least 12 %.

B.2.4 Depreciation and amortization

These are known as non-cash charges, as the company is not actually spending any money on them. It is usually sensible to ignore them for LCC purposes as they tend to mask the sensitivities of a company's operating cash flow analysis comparisons.

Depreciation is an accounting convention for tax purposes that allows companies to get a benefit on capital expenditures as assets, such as computers, plant, machinery, etc. to account for their wear-out. There are usually set periods over which an asset may be depreciated before it is "written off" or scrapped and replaced.

Amortization is a technique for writing off intangibles such as "goodwill" when taking over another company, being forced to amortize over a set period of time according to generally accepted accounting principles (GAAP).

B.2.5 Cost-benefit analysis

Given a series of LCC options, a method has to be used to identify the effectiveness of each option in meeting the specified requirements.

A common term used is the "bang-per-buck" factor. It expresses the result of a trade-off analysis which identifies the most cost-effective solution of those available.

There is a real risk in accepting the cheapest LCC option without considering how many of the requirements have been sacrificed in comparison with other, more expensive options.

Common factors used to trade-off for LCC are

- operational availability,
- intrinsic availability,
- spares cost,
- manpower cost,
- probability of mission success.

Comparison of options against similar evaluation criteria may significantly change the order of preference of the options.

Annex C (informative)

Example of a life cycle cost analysis

C.1 General

The following example describes the life cycle costing procedure and some methods for estimation of life cycle costs. The example refers to a product called “data communication network (DCN)”. The product breakdown structure, shown in clause C.3, lists the different elements included in the DCN.

The purpose of the analysis is to identify those cost elements whose contribution exceeds predefined levels (e.g. x % of total LCC). To simplify the example, a number of potential important costs have been excluded, e.g. costs for documentation, training, infrastructure, administration, installation and maintenance of test equipment.

The analysis is based on “constant prices” and long-term mean values of time, cost and technical parameters. A period of 15 years of operation of the product has been selected for the analysis.

The availability of this type of data communication network is typically about 99,994 %. This corresponds to approximately 30 min accumulated down time per year.

The following costs, related to the operation and maintenance phase, are considered relevant for this example:

Cost element	Abbreviation
Total costs for 15 years' operation and maintenance	COM
Investments	CI
Operation	CO
Maintenance	CM
Costs for investments for maintenance	CIM
Spare replaceable units	CIMSRU
Facilities for maintenance at site	CIMFS
Facilities for maintenance at workshop	CIMFW
Costs for annual operation	CYO
Leasing of the data transport network	CYOL
Software upgrading	CYOS
Penalty costs due to accumulated downtime of the DCN	CYOU
Costs for annual maintenance (labour and consumables)	CYM
Preventive maintenance	CYMP
Corrective maintenance	CYMC
Corrective maintenance at site	CYMCS
Corrective maintenance at workshop	CYMCW

The cost breakdown structure (CBS) for the product under consideration is shown in Figure C.2.

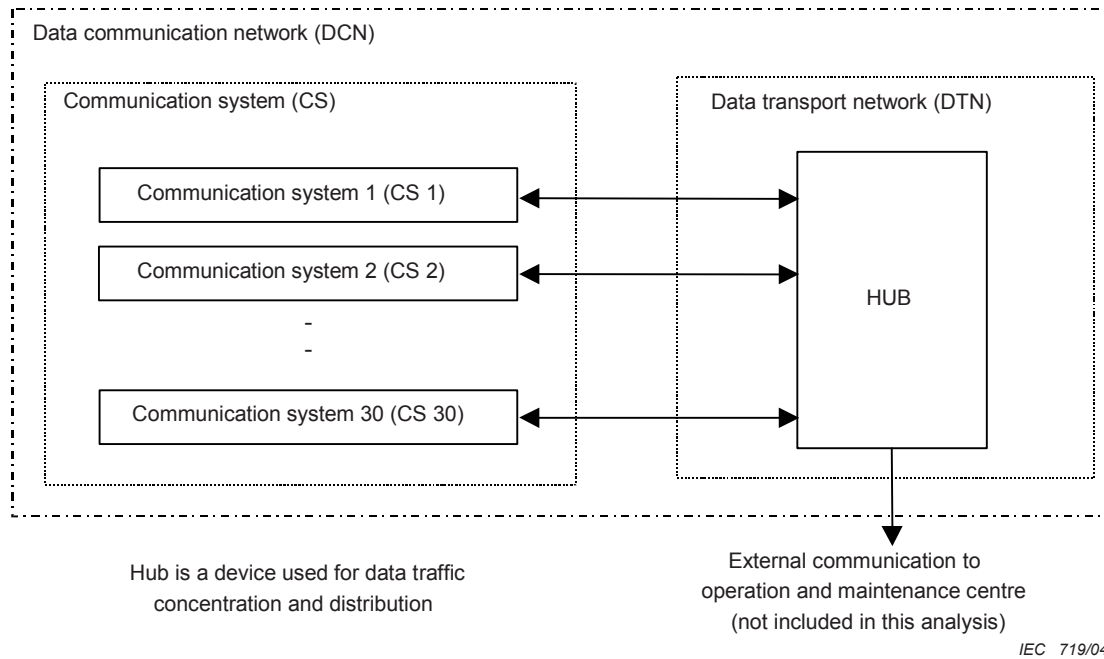

Figure C.1 – Structure of DCN

The analysis is performed using the following steps:

- definition of an appropriate cost breakdown structure (see Clause C.2);
- defining a detailed product breakdown structure including a compilation of technical and cost data for the product (see Clause C.3);
- definition of cost categories (see Clause C.4);
- establish relation between the product breakdown structure and the cost categories defined by means of cost elements (CE) (see Clause C.5);
- establish preconditions and assumptions for the analysis (see C.6.1);
- perform the cost calculations (see Clause C.6);
- presentation of costs in accordance with the cost breakdown structure.

C.2 Cost breakdown structure (CBS)

The cost breakdown structure (CBS) is a life cycle oriented way of classifying costs. The CBS links the different costs to meet the needs of the analysis.

The individual cost is defined by a corresponding cost element. See Clause C.1.

The CBS below describes the relationship between costs applicable to this example.

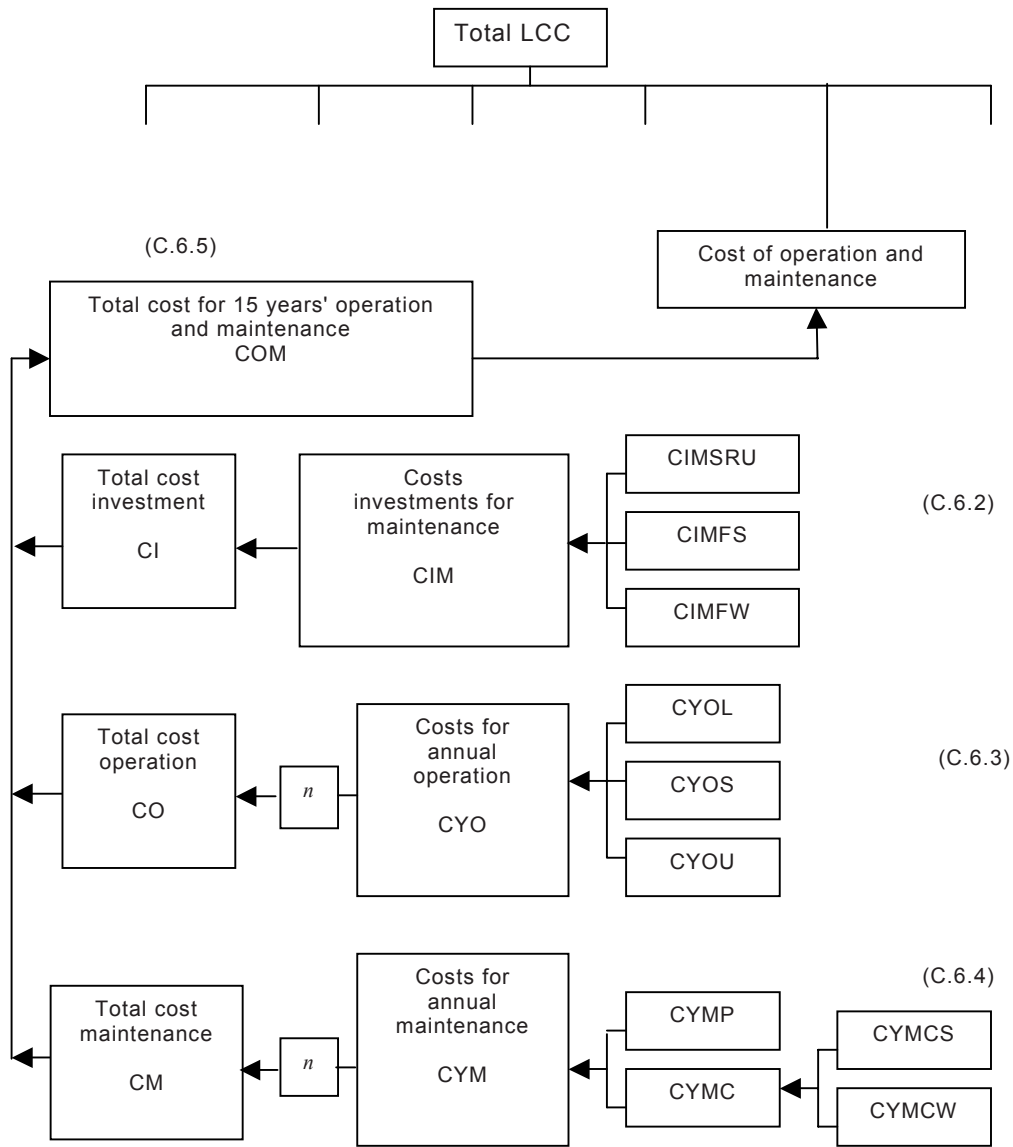

IEC 720/04

$n = 15$ (number of years of operation considered in the analysis)

Figure C.2 – Cost breakdown structure used for the example in Figure C.1

C.3 Product breakdown structure

To perform the required calculations in accordance with the cost breakdown structure given in Figure C.2, a detailed product breakdown structure should be worked out. The product breakdown structure gives the breakdown of the product to lower indenture levels.

Tables C.1 to C.5 present a product breakdown structure, in three indenture levels, together with some product dependability and cost data.

As shown in Figure C.1, the product “P” under consideration is a data communication network (DCN) consisting of N identical communication systems (CS) and a data transport network (DTN). The data transport network contains all data links within the DCN.

Table C.1 – First indenture level – Data communication network

Level 1	Item name	Abbreviation	Required availability performance	Quantity <i>N</i>
P ₁	Communication system	CS	All downtime results in penalty cost	30
P ₂	Data transport network	DTN	99,995 % per link	30 (1 per link)

Table C.2 – Second indenture level – Communication system

Level 2	Item name	Abbreviation	Failure intensity (<i>z</i>) failures/10 ⁶ /h	Cost per item CU	Quantity <i>N</i>
P _{1.1}	Power supply system	PSS	See Table C.3	See Table C.3	1
P _{1.2}	Main processor	MP	See Table C.4	See Table C.4	1
P _{1.3}	Display console	DC (RU)	5 per item	900	2
P _{1.4}	Input/ output unit	IOU (RU)	4 per item	300	1
P _{1.5}	Fan system	FS	See Table C.5	See Table C.5	1

NOTE Replaceable unit (RU) is to be repaired at the “workshop level” and to be replaced at the “site level”.

Tables C.2 to C.5 give the cost for the purchase of replaceable units and consumables for the operation and maintenance (O&M) phase.

The display console and the input/output unit are “replaceable units” and their further breakdown is not necessary. The breakdown structure of the other items is described in Tables C.3 to C.5.

Table C.3 – Third indenture level – Power supply system

Level 3	Item name	Abbreviation	Failure intensity (<i>z</i>) failures/10 ⁶ /h	Cost per item CU	Quantity <i>N</i>
P _{1.1.1}	Power supply unit	PSU (RU)	18 per item	350	2
P _{1.1.2}	Power control unit	PCU (RU)	4 per item	200	1
P _{1.1.3}	Battery ^a	BATT (C)	Negligible	100	8

Table C.4 – Third indenture level – Main processor

Level 3	Item name	Abbreviation	Failure intensity (<i>z</i>) failures/10 ⁶ /h	Cost per item CU	Quantity <i>N</i>
P _{1.2.1}	Central processor	CP (RU)	15 per item	4 000	2
P _{1.2.2}	Program store	PS (RU)	18 per item	1 000	2
P _{1.2.3}	Data store	DS (RU)	22 per item	800	4
P _{1.2.4}	Data bus system	DBS (RU)	3 per item	400	1

Table C.5 – Third indenture level – Fan system

Level 3	Item name	Abbreviation	Failure intensity (<i>z</i>) failures/10 ⁶ /h	Cost per item CU	Quantity <i>N</i>
P _{1.5.1}	Fan	FAN (C) ^a	Negligible	40	4
P _{1.5.2}	Alarm unit	AU (RU)	2 per item	80	1

^a Consumables. The battery and the fan require preventive replacement due to wear-out failures.

C.4 Cost categories

The costs represented in the cost breakdown structure are grouped into cost categories as shown in Table C.6. Investment costs are the total costs for the period under study, 15 years in this example. The remaining costs are on annual basis.

Table C.6 – Cost categories

Cost category	Cost for
R_1	Investment in facilities for maintenance at site
R_2	Investment in facilities for maintenance at workshop
R_3	Investment in spare replaceable units (SRU)
R_4	Cost of consumables for maintenance at site
R_5	Cost of consumables for maintenance at workshop
R_6	Cost of preventive maintenance
R_7	Cost of corrective maintenance at site
R_8	Cost of corrective maintenance at workshop
R_9	Cost of software upgrading
R_{10}	Cost of leasing of data transport network
R_{11}	Penalty cost due to accumulated downtime of DCN

C.5 Definition of cost elements

A cost element (CE) is the link between an individual item of the product/work breakdown structure and a cost category under consideration. Cost elements are defined item by item as applicable. The calculation of costs in Clause C.6 refers to the cost elements defined in Figure C.3. The cost elements are the reference for all calculations, as well as for the aggregation of costs, in accordance with cost breakdown structure.

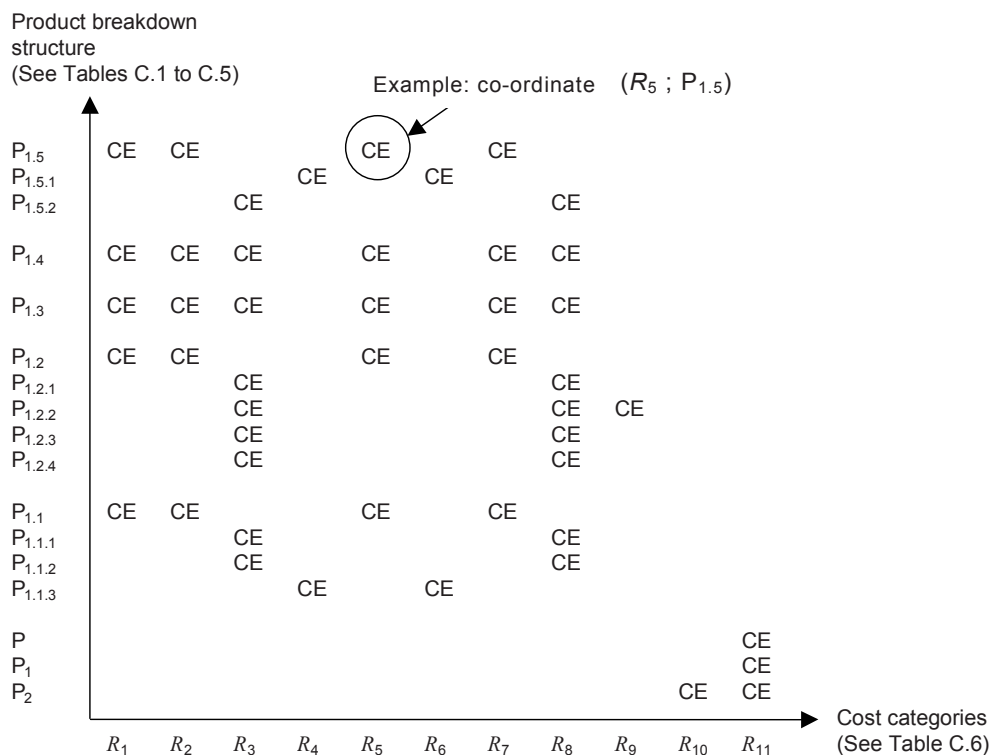

Figure C.3 – Definition of cost elements

C.6 Calculation of costs

C.6.1 Preconditions and assumptions

The calculations in this example are based on the following estimated performance parameters and costs, and on other conditions:

- Mean repair time (MRT) = 0,5 h;
- Mean technical delay (MTD) = 0,25 h;
- Mean administrative delay (MAD) = 4 h;
- Mean logistic delay (MLD) = to be calculated;
- Cost per person hour (CPH) = CU 15;
- Cost for DCN service downtime (CSD) = CU 25/min per communication system;
- Useful life of a battery = 4 years;
- Useful life of a fan = 9 years;
- No preventive maintenance except for batteries and fans;
- Cost for software upgrading including installation = CU 3 000 per communication system;
- Interval for software upgrading = 1,5 years;
- A central maintenance organization is used for maintenance at sites;
- All replaceable units are repaired at a central workshop;
- Turn-around-time (TAT) for replaceable units = 720 h (=30 days) ;
- Cost for a portable test equipment for site maintenance (CPTS) = CU 2 500;
- Cost for leasing of the data transport network = CU 50 000 per year.

To simplify calculations and to get a reasonable short average waiting time for spare replaceable units (SRUs), a shortage probability (SP) of 1 % is used in this example. In a more detailed calculation an optimization of the RUs investment, based on purchase costs and availability requirements, should be performed. The term $(1 - SP)$ is sometimes called "level of protection".

Failure intensities (λ) and purchase costs for replaceable units and consumables are given in Tables C.1 to C.5.

The scheduled service time for DCN is assumed to be 24 hours a day, 7 days a week.

The occurrence of failures in a given time interval is assumed to follow a homogeneous Poisson process. Thus the waiting time between consecutive failure occurrences is exponentially distributed (independent of time). It is also assumed that there are as many repairmen as faults.

The calculations below refer to the cost breakdown structure shown in Figure C.2 and to the cost elements shown in Figure C.3.

C.6.2 Costs investments for maintenance (CIM)

C.6.2.1 General

With the explanations given in Clause C.1, CIM is made up of the costs for spare replaceable units (CIMSru), the costs for facilities for maintenance at site (CIMFS) and the costs for facilities for maintenance at workshop (CIMFW). The calculations for these costs are given in C.6.2.2 to C.6.2.6.

C.6.2.2 Costs, spare replaceable units (CIMSRU)

According to Figure C.3, cost elements (R_3 ; $P_{1.1.1}$ to $P_{1.5.2}$) apply where

- R_3 is the investment in spare replaceable units (see Table C.6),
- $P_{1.1.1}$ is the power supply unit (PSU),
- $P_{1.1.2}$ is the power control unit (PCU),
etc. (see RUs in Tables C.1 to C.5).

For this example, an expression, derived from the Poisson distribution is used to calculate the required number of spare replaceable units (NSRU). This expression relates failure intensity λ to the required number of spares (NSRU) at some level of protection ($1 - SP$) given a specified turn-around-time (TAT) for the repair of replaceable units (RU). In accordance with C.6.1, $(1 - SP) = 0,99$.

The mean waiting time (MWT) for a spare replaceable unit (SRU) at store can be approximated as:

$$MWT_{RU} = SP \times TAT / (NSRU_{RU} + 1) \text{ h}$$

NOTE MWT will be used in C.6.2.3 for the calculation of the mean logistic delay.

Using the above equation, the required number of spare replaceable units (NSRU) per replaceable unit (RU) including investments and mean waiting times (MWT) is given in Table C.7.

Table C.7 – Investments in spare replaceable units

Replacement unit RU	Number of spare replaceable units NSRU	Purchase cost per item CU	Total investment per SRU type CU	Denomination	Mean waiting times MWT h
RU ₁ (PSU)	3	350	1 050	CIMSRU(PSU)	1,8
RU ₂ (PCU)	1	200	200	CIMSRU(PCU)	3,6
RU ₃ (CP)	3	4 000	12 000	CIMSRU(CP)	1,8
RU ₄ (PS)	3	1 000	3 000	CIMSRU(PS)	1,8
RU ₅ (DS)	6	800	4 800	CIMSRU(DS)	1,0
RU ₆ (DBS)	1	400	400	CIMSRU(DBS)	3,6
RU ₇ (DC)	2	900	1 800	CIMSRU(DC)	2,4
RU ₈ (IOU)	1	300	300	CIMSRU(IOU)	3,6
RU ₉ (AU)	1	80	80	CIMSRU(AU)	3,6
TOTAL	—	—	23 630	CIMSRU	—
NOTE CIMSRU = CU 23 630.					

C.6.2.3 Calculation of mean logistic delay (MLD)

To simplify calculations of “unavailability associated costs” (CYOU), a uniform value of MTTR, applicable to all parts of DCN, will be used for all availability calculations.

$$MTTR = MRT + MTD + MAD + MLD$$

NOTE For the meaning and values of MRT, MTD and MAD, see C.6.1.

The mean logistic delay (MLD) is calculated as the weighed average of the mean waiting times, i.e.

$$MLD = \frac{\sum_{RU_1}^{RU_9} (N_z)_{RU} MWT_{RU}}{\sum_{RU_1}^{RU_9} (N_z)_{RU}}$$

Using the values from Tables C.2 to C.7:

$$MLD = 1,6 \text{ h}$$

C.6.2.4 Costs, facilities for maintenance at site (CIMFS)

According to Figure C.3, cost elements (R_1 ; $P_{1.1}$ to $P_{1.5}$) apply, where

R_1 is the investment in facilities for maintenance at site (see Table C.6);

$P_{1.1}$ to $P_{1.5}$ (see Table C.2).

Facilities for maintenance at site consist of portable test equipment. It is assumed that the equipment is used in connection with all types of corrective maintenance at site. The required number of equipments depends on the demand rate, which is related to the number of corrective maintenance actions.

Using failure intensities and quantities from Tables C.2 to C.5, the expected total number of corrective maintenance actions (NCMA) per year, for 30 communication systems, can be calculated as:

$$\begin{aligned} NCMA &= 30 \times (5 \times 2 + 4 \times 1 + 18 \times 2 + 4 \times 1 + 15 \times 2 + 18 \times 2 + 22 \times 4 + 3 \times 1 + 2 \times 1) \times 10^{-6} \times 8\,760 \\ &= 56 \text{ actions per year.} \end{aligned}$$

The expected mean time between corrective actions will be $8\,760/56 = 156 \text{ h}$.

Using data from C.6.1 and MLD above, the MTTR can be calculated to be equal to 6,35 h. The average utilization time of the portable test equipment per corrective maintenance action is approximately $4 + 0,25 + 0,5 + 4 \approx 9 \text{ h}$. This is a short time in comparison with the period of 156 h.

Estimation gives that investment (CIMFS) in two portable test equipments should give an acceptable accessibility to the test equipment. The average waiting time for the portable test equipment is included in the mean administrative delay (MAD) above.

CPTS = CU 2 500 (cost for a portable test equipment);

CIMFS = 2 x CPTS = CU 5 000.

C.6.2.5 Costs, facilities for maintenance at workshop (CIMFW)

According to Figure C.3, cost elements (R_2 ; $P_{1.1}$ to $P_{1.5}$) apply, where

R_2 is the investment in facilities for maintenance at workshop (see Table C.6);

$P_{1.1}$ to $P_{1.5}$ (see Table C.2).

The estimated cost of test equipment for fault localization and function checkout of replaceable units is equal to CU 30 000. The value is based on experiences from similar products.

CIMFW = CU 30 000.

C.6.2.6 Summary of costs

The total investment for maintenance is

$$\begin{aligned} \text{CIM} &= \text{CIMSURU} + \text{CIMFS} + \text{CIMFW}, \\ \text{CIM} &= 23\,630 + 5\,000 + 30\,000 = \text{CU } 58\,630. \end{aligned}$$

C.6.3 Costs for annual operation (CYO)

C.6.3.1 Costs, leasing of the data transport network (CYOL)

According to Figure C.3, cost elements (R_{10} ; P_2) apply, where

R_{10} is the cost of leasing data transport network (see Table C.6);
 P_2 (see Table C.1).

According to C.6.1:

$$\text{CYOL} = \text{CU } 50\,000.$$

C.6.3.2 Costs, software upgrading (CYOS)

According to Figure C.3, cost elements (R_9 ; $P_{1.2.2}$) apply, where

R_9 is the cost of software upgrading (see Table C.6);
 $P_{1.2.2}$ (see Table C.4).

According to C.6.1, the interval for upgrading of software is 1,5 years and the cost of upgrading per communication system is CU 3 000. Ten upgrades during 15 years are required. The average yearly cost for 30 communication systems is:

$$\text{CYOS} = 30 \times 3\,000 \times 10/15 = \text{CU } 60\,000.$$

C.6.3.3 Costs, penalty due to downtime (CYOU)

According to Figure C.3, cost elements (R_{11} ; P , P_1 , P_2) apply where

R_{11} is the cost penalty due to product down time or unavailability (see Table C.6);
 P_1 , P_2 (see Table C.1).

Cost of product down time or unavailability is calculated as:

$$\text{CYOU} = 30 \times (\text{MADTCS} + \text{MADTD TN}) \times \text{CSD}$$

where

MADTCS is the mean accumulated down time of a communication system (minutes/year);
MADTD TN is the mean accumulated down time of the data transport network (minutes/year);
CSD is the cost for DCN service downtime per minute per communication system in accordance with C.6.1;

and

$$\begin{aligned} \text{MADTCS} &= 8760 \times 60 \times (1 - \text{ACS}); \\ \text{MADTD TN} &= 8760 \times 60 \times (1 - \text{ADTN}); \end{aligned}$$

where

ACS is the availability of the communication system;

ADTN is the availability of the data transport network;

ACS = APSS x AMP x ADC² x AIOU x AFS per communication system;

ADTN = 99,995 % per link in accordance with Table C.1;

where

APSS is the availability performance of the power supply system;

AMP is the availability performance of the main processor;

ADC is the availability performance of the display console;

AIOU is the availability performance of the input/output unit;

AFS is the availability performance of the fan system.

The individual availability values for each of the above systems are calculated using the formula:

$$A = \mu / (\mu + z)$$

where

$$\mu = 1/\text{MTTR} \quad \text{and} \quad \text{MTTR} = \text{MRT} + \text{MTD} + \text{MAD} + \text{MLD} = 0,5 + 0,25 + 4 + 1,6 = 6,35 \text{ h.}$$

Power supply system (PSS)

Due to redundant power supply units and the fact that not all failures in power control units affect the power supply system, the system failure intensity of the power supply system can be estimated to be 3 failures/10⁶ h and APSS = 99,998 %.

Main processor (MP)

The main part of the MP is duplicated. However, due to faults in the data bus system (DBS) and downtimes related to built-in software restoration processes, its availability using

$$A = \mu / (\mu + z)$$

is estimated to be AMP = 99,995 %.

Display console (DC)

$$\text{ADC} = \mu / (\mu + 5 \times 10^{-6})$$

$$\text{ADC} = 99,9968 \text{ \%}.$$

Input/output unit (IOU)

$$\text{AIOU} = \mu / (\mu + 4 \times 10^{-6})$$

$$\text{AIOU} = 99,9975 \text{ \%}.$$

Fan system (FS)

Due to redundancy, the availability of the fan system is assumed to be 100 %. Therefore, the availability of the communication system:

$$\text{ACS} = 99,984 \text{ \%}$$

and

MADTCS = 84,1 min per year,

MADDTN = 26,3 min per year.

The cost penalty due to product down time or unavailability:

$$\text{CYOU} = 30 \times (84,1 + 26,3) \times 25 = \text{CU } 82\,800.$$

C.6.3.4 Total costs for annual operation (CYO)

As now all the components of CYO are known, the total cost for annual operation is

$$\text{CYO} = 50\,000 + 60\,000 + 82\,800 = \text{CU}192\,800.$$

C.6.4 Costs for annual maintenance (CYM)

C.6.4.1 General

CYM includes cost for “labour” and “consumables”.

C.6.4.2 Costs, preventive maintenance (CYMP)

According to Figure C.3, cost elements (R_6 ; $P_{1.1.3}$, $P_{1.5.1}$) apply, where

R_6 is the cost of preventive maintenance (see Table C.6);

$P_{1.1.3}$, $P_{1.5.1}$ (see Tables C.3 and C.5).

Cost for change of batteries:

$$\text{CYMPBATT} = \text{cost of batteries (CBATT)} + \text{cost of maintenance (MPH} \times \text{CPH)}.$$

The required maintenance personnel hours (MPH) per preventive action is assumed to be:

$$10 \text{ h (2 person} \times 5 \text{ h)}.$$

In accordance with C.6.1, the interval for change of batteries is 4 years. Thus three battery changes occur over 15 years. Cost per person hour (CPH) = CU 15.

In accordance with Table C.3, the cost per battery is CU 100 and there are eight batteries in each communication system.

Thus the average yearly cost, including all communication systems, based on a total 15 years' operation is:

$$\text{CYMPBATT} = 30 \times 3/15 \times ((8 \times 100) + (10 \times 15)) = \text{CU } 5\,700.$$

Cost for change of fans:

$$\text{CYMPFAN} = \text{Cost of fans (CFAN)} + \text{cost of maintenance (MPH} \times \text{CPH)}.$$

The required maintenance person hours (MPH) per preventive action is assumed to be equal to 20 h (2 persons \times 10 h).

In accordance with C.6.1, the interval for change of fans is 9 years. Thus one replacement occurs over 15 years. Cost per person hour (CPH) = CU 15.

In accordance with Table C.5, the cost per fan is CU 40 and there are four fans in each communication system.

Thus the average yearly cost, including all communication systems, based on total 15 years' operation is:

$$\text{CYMPFAN} = 30 \times 1/15 \times ((4 \times 40) + (20 \times 15)) = \text{CU } 920.$$

As now both the components of CYMP are known, the total annual cost for preventive maintenance is:

$$\text{CYMP} = 5\,700 + 920 = \text{CU } 6\,620.$$

C.6.4.3 Costs, corrective maintenance (CYMC)

Costs, corrective maintenance at site (CYMCS)

According to Figure C.3, cost elements (R_7 ; $P_{1.1}$ to $P_{1.5}$) apply, where

R_7 is the cost of corrective maintenance at site (see Table C.6);

$P_{1.1}$ to $P_{1.5}$ (see Table C.2).

$\text{CYMCS} = \text{NCMA} \times \text{MPH} \times \text{CPH} + \text{NCMA} \times \text{average cost of consumables per maintenance action}.$

NCMA is the total number of corrective maintenance actions per year = 56 (see C.6.2.4.) One person is required per corrective maintenance action at site.

MPH per corrective maintenance action at site is assumed to be:

$$\text{MRT} + \text{MTD} + 2 \times \text{MAD} + 1 \text{ h} = 9,75 \text{ h}.$$

In accordance with C.6.1, the cost per personnel hour is equal to CU 15. The average cost of consumables per corrective maintenance action is assumed to be CU 14.

$$\text{CYMCS} = 56 \times 9,75 \times 15 + 56 \times 14 = \text{CU } 8\,974.$$

Costs, corrective maintenance at workshop (CYMCW)

According to Figure C.3, cost elements (R_8 ; $P_{1.1.2}$ to $P_{1.5.2}$) apply, where

R_8 is the cost of corrective maintenance at workshop (see Table C.6);

$P_{1.1.2}$ to $P_{1.5.2}$ (see Tables C.3 to C.5).

$\text{CYMCW} = \text{NCMA} \times \text{MPH} \times \text{CPH} + \text{NCMA} \times \text{average cost of consumables per repair}.$

The average MPH per repair is assumed to be 3 h.

MPH per corrective maintenance action at workshop is assumed to be 3 h.

The average cost for consumables, per repair, is assumed to be CU 18.

In accordance with C.6.1, the cost per person hour = CU 15.

$$\text{CYMCW} = 56 \times 3 \times 15 + 56 \times 18 = \text{CU } 3\,528.$$

As now all the components of CYMC are known, the total annual cost for corrective maintenance is:

$$\text{CYMC} = 8\,974 + 3\,528 = \text{CU } 12\,502.$$

C.6.4.4 Summary

As now all the components of CYM are known, the total cost for annual maintenance is:

$$\text{CYM} = \text{CYMP} + \text{CYMC} = 6\,620 + 12\,502 = \text{CU } 19\,122.$$

C.6.5 Total costs for 15 years' operation and maintenance (COM)

Total cost of investments (CI) = CIM = CU 58 630

Total cost of operation (CO) = 15 x CYO = 15 x 192 800 = CU 2 892 000

Total cost of maintenance (CM) = 15 x CYM = 15 x 19 122 = CU 286 830

Total cost for 15 years' operation and maintenance (COM)

$$= \text{CI} + \text{CO} + \text{CM} = \text{CU } 3\,237\,460.$$

C.6.6 Presentation of undiscounted costs related to the cost breakdown structure

A comparison of the costs of investment, annual operation and maintenance is shown in Figure C.4.

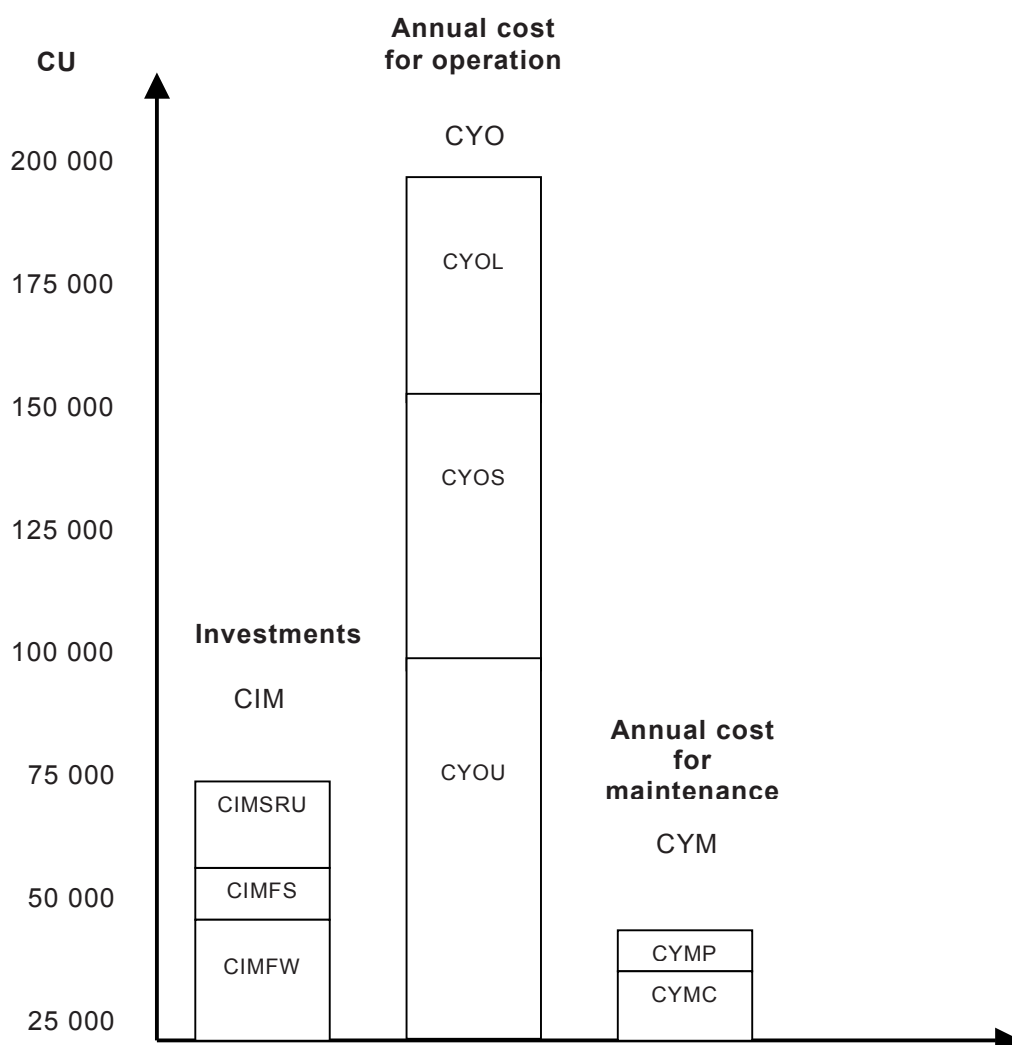

IEC 722/04

Figure C.4 – Comparison of the costs of investment, annual operation and maintenance

C.7 Examples of some possible improvement options to lower LCC

C.7.1 Data store reliability

Installation of a more reliable data store gives a 50 % lower failure intensity of the DS module. The purchase cost of the new DS is assumed to be CU 1 000 instead of CU 800. The improved reliability will reduce the required spare replaceable units (RU₅) to four items instead of six as shown in Table C.7.

Thus the initial investment will increase by $30 \times 4 \times 200 = \text{CU } 24\,000$.

$$\text{CIMS RU will be } 23\,630 - 4\,800 + 4 \times 1\,000 = \text{CU } 22\,830.$$

The effect on mean waiting time (MWT) is neglected.

The number of corrective maintenance action will be reduced from 56 to 44. This will reduce CYMCS to CU 7 7051 and CYMCW to CU 2 772.

The main saving for this investment however will be in the area of product unavailability cost (CYOU), as this should increase the availability of the main processor. The AMP is estimated to be 99,998 % instead of 99,995 %. This provides an overall system availability ACS of 99,987 % thus giving a communication system accumulated downtime of 68,3 min per year, and a cost penalty due to product down time or unavailability (CYOU) of CU 70 950 per year.

C.7.2 Display console

Investment in one extra display console per communication system, to get a two-out-of-three redundancy, gives $\text{ADC} = 0,999999997$ for this configuration.

The ACS will increase to $(0,99984 \times 0,999999997)/(0,999968)^2 = 0,9999$.

This will reduce MADTCS from 84,1 min per year to 52,6 min per year, and this gives a reduction of the product unavailability cost (CYOU) that equals:

$$30 \times (84,1 - 52,6) \times 25 = \text{CU } 23\,625 \text{ per year.}$$

The initial investment in display consoles will increase by $30 \times 900 = \text{CU } 27\,000$.

The required number of spares RU7 (DC) will still be 2.

The number of corrective maintenance actions per year will increase by

$$30 \times 5 \times 1 \times 10^{-6} \times 8760 = 1,3 \text{ actions per year, equal to } 2,3 \text{ \%}.$$

Thus, the CYMCS = $1,023 \times 8\,974 = \text{CU } 9\,180$ and CYMCW = $1,023 \times 3\,528 = \text{CU } 3\,609$.

C.7.3 Data transport network

Introduction of a redundancy in the data transport network will give improved link availability performance. However, the cost for leasing (CYOL) will increase by, say, 25 %. Thus, CYOL will be $1,25 \times 50\,000 = \text{CU } 62\,500$ per year.

ADTN is then assumed to be 99,9994 and the MADTDTN will be 3,15 min per year.

The unavailability cost (CYOU) will be *reduced* by

$$30 \times (26,3 - 3,15) \times 25 = \text{CU } 17\,363 \text{ per year.}$$

C.7.4 Software upgrading

A remote software upgrading will reduce the cost per upgrading per communication system from CU 3 000 to CU 300. Thus, the cost for software upgrading (CYOS) will be *reduced* by

$$30 \times (3000 - 300) \times 10 / 15 = \text{CU } 54\,000 \text{ per year.}$$

Investment in new facilities for the remote upgrading function is assumed to be CU 1 500 per communication system and 100 000 in central data equipment. Thus, the initial investment will *increase* by

$$(30 \times 1\,500) + 100\,000 = \text{CU } 145\,000.$$

C.8 Revenue generation to be used for discounted cash flow analyses

The revenue from the use of the data communication network is estimated to be:

- CU 600 000/year for year 5 to 11;
- CU 75 000 for year 1 and 15 each;
- CU 225 000 for year 2 and 14 each;
- CU 375 000 for year 3 and 13 each;
- CU 525 000 for year 4 and 12 each.

C.9 Example illustrating cash flow analysis

C.9.1 General

In order to analyse the cash flows associated with different LCC options, it is necessary to recalculate the costs in this example. This is required so that the “per-year” expenditures and revenues can be determined, and discounted cash flow techniques can be illustrated.

In this example, the first year of operation will be known as year 0. Other conventions may apply in different applications.

Residual value is assumed to be zero at the end of the operation and maintenance phase.

C.9.2 Cost of spare replaceable units

CIMSRU (See C.6.2.2)

As part of the investment cost for maintenance, CIMSRU is spent prior to the start of the operation and maintenance phase. It is therefore assumed that it is expended at the beginning of year 0.

Year	0	1	2	3	4	5	6	7	8	9	10	11	12	13	14	15
UC(000)	23,63															

C.9.3 Cost of facility for maintenance at site

CIMFS (See C.6.2.4)

Similarly to CIMSRU, it is assumed that CIMFS is spent at the beginning of the year.

Year	0	1	2	3	4	5	6	7	8	9	10	11	12	13	14	15
CU(000)	5,0															

C.9.4 Cost of facilities for maintenance at workshop

CIMFW (See C.6.2.5)

Similarly to CIMSRU, it is assumed that CIMFW is spent at the beginning of the year.

Year	0	1	2	3	4	5	6	7	8	9	10	11	12	13	14	15
CU(000)	30,0															

C.9.5 Cost of leasing of the data transport network

CYOL (See C.6.3.1)

In C.6.3.1, costs per annum are calculated to be CU 50,000.

Year	0	1	2	3	4	5	6	7	8	9	10	11	12	13	14	15
CU(000)	50,0	50,0	50,0	50,0	50,0	50,0	50,0	50,0	50,0	50,0	50,0	50,0	50,0	50,0	50,0	

C.9.6 Cost of software upgrading

CYOS (See C.6.3.2)

Software upgrading costs are CU 3 000 per system = CU 3 000 x 30 =CU 90 000.

Upgrades will be required in years 1, 3, 4, 6, 7, 9, 10, 12, 13, 15.

Year	0	1	2	3	4	5	6	7	8	9	10	11	12	13	14	15
CU(000)		90		90	90		90	90		90	90		90	90		90

C.9.7 Cost penalty due to product down time or unavailability

CYUO (See C.6.3.3)

The penalty cost of the system for being unavailable is CU 82 800 per year of operation.

Year	0	1	2	3	4	5	6	7	8	9	10	11	12	13	14	15
CU(000)	82,8	82,8	82,8	82,8	82,8	82,8	82,8	82,8	82,8	82,8	82,8	82,8	82,8	82,8	82,8	

C.9.8 Cost of batteries

CYMPBATT (See C.6.4.2)

Batteries require replacement for preventative maintenance purposes every 4 years. The cost of a battery is CU 100 and there are eight batteries per system, and 30 systems. Labour cost is CU 150 per system (10 h at CU 15/h).

Battery costs are therefore CU (100 x 8 x 30) per replacement = CU 24 000.

Labour costs are therefore CU (30 x 150) per replacement = CU 4 500.

Total replacement costs are therefore CU (24,000 + 4,500) = CU 28 500.

Replacements will be required in years 4, 8, 12.

Year	0	1	2	3	4	5	6	7	8	9	10	11	12	13	14	15
CU(000)					28,5				28,5				28,5			

C.9.9 Cost of fans

CYMPFAN (See C.6.4.2)

Fans require replacement every 9 years at a cost of CU 40 per fan, and there are four fans per system. Labour cost is CU 300 (20 h at CU 15/h).

Fan costs are therefore CU (30 x 40 x 4) per replacement = CU 4 800.

Labour costs are CU (30 x 300) per replacement = CU 9 000.

Total replacement costs are therefore CU (4 800 + 9 000) = CU 13 800.

Replacement will be required in year 9.

Year	0	1	2	3	4	5	6	7	8	9	10	11	12	13	14	15
CU(000)										13,8						

C.9.10 Cost of corrective maintenance at site

CYMCS (See C.6.4.3)

As the population and usage of the systems is constant throughout the O&M phase, the cost of corrective maintenance at site is assumed to be constant. Annual cost is therefore as follows:

Year	0	1	2	3	4	5	6	7	8	9	10	11	12	13	14	15
CU(000)	9,0	9,0	9,0	9,0	9,0	9,0	9,0	9,0	9,0	9,0	9,0	9,0	9,0	9,0	9,0	

C.9.11 Cost of corrective maintenance at workshop

CYMCW (See C.6.4.3)

As the population and usage of the systems is constant throughout the O&M phase, the cost of corrective maintenance at workshop is assumed to be constant. Annual cost is therefore as follows:

Year	0	1	2	3	4	5	6	7	8	9	10	11	12	13	14	15
CU(000)	3,5	3,5	3,5	3,5	3,5	3,5	3,5	3,5	3,5	3,5	3,5	3,5	3,5	3,5	3,5	

C.10 Life cycle cost outputs**C.10.1 Benefits of discounting**

The benefits of applying discounted cash flow (DCF) techniques in order to provide the net present value of the future cash flows can be seen from Figures C.5, C.6 and C.7.

The reduction in LCC budgets is achieved by attributing the revenue generated by investing the future cost flows until they are needed.

C.10.2 Design option trade-off

A further benefit of applying DCF is to determine the benefits (or penalties) during design options trade-offs. It will be observed that the data store in the main processor contributes about 41 % of all required maintenance actions in NCMA.

If this data store could be made more reliable – say from 22 failures per million hours (fpmh), down to 15 fpmh at an investment cost of, say, CU 20 000, then this investment cost could be spread over the population of systems ($30 \times 4 = 120$) plus the spares. The improved reliability will reduce the spares required to 4 bringing the unit population to 124. The cost per unit will therefore be

$$\text{CU } (20\,000/124 + 800) = \text{CU } 961.$$

This will, in fact reduce the cost to CU 3 844 for RU5(DS), and also reduce CIMSRU to CU 22 674.

The main saving for this investment however, will be in the area of product unavailability cost (CYOU), as this should increase the availability of the main processor from 99,995 % to 99,997 %. This provides an overall availability ACS of 99,9861 %, giving a communications system downtime of 73 min per year, and an unavailability cost (CYOU) of CU 77 475 per year.

These changes are summarized in Figure C.7. There is an "over life" cost saving in undiscounted terms of CU 000s ($3\,237,5 - 3\,156,7$) = CU 80 800 (2,49 %), and a discounted saving of CU 000s ($2\,332,8 - 2\,273,8$) = CU 59 000 (2,53 %).

These savings are achieved by an additional investment of 0,006 % in undiscounted cost.

Year	0	1	2	3	4	5	6	7	8	9	10	11	12	13	14	15
CIMSRU	23,63	0,00	0,00	0,00	0,00	0,00	0,00	0,00	0,00	0,00	0,00	0,00	0,00	0,00	0,00	0,00
CIMFS	5,00	0,00	0,00	0,00	0,00	0,00	0,00	0,00	0,00	0,00	0,00	0,00	0,00	0,00	0,00	0,00
CIMFW	30,00	0,00	0,00	0,00	0,00	0,00	0,00	0,00	0,00	0,00	0,00	0,00	0,00	0,00	0,00	0,00
CYOL	50,00	50,00	50,00	50,00	50,00	50,00	50,00	50,00	50,00	50,00	50,00	50,00	50,00	50,00	50,00	0,00
CYOS	0,00	90,00	0,00	90,00	90,00	0,00	90,00	90,00	0,00	90,00	90,00	0,00	90,00	90,00	0,00	90,00
CYUO	82,80	82,80	82,80	82,80	82,80	82,80	82,80	82,80	82,80	82,80	82,80	82,80	82,80	82,80	82,80	0,00
CYMPBAT	0,00	0,00	0,00	0,00	28,50	0,00	0,00	0,00	28,50	0,00	0,00	0,00	28,50	0,00	0,00	0,00
CYMPFAN	0,00	0,00	0,00	0,00	0,00	0,00	0,00	0,00	0,00	13,82	0,00	0,00	0,00	0,00	0,00	0,00
CYMCS	8,97	8,97	8,97	8,97	8,97	8,97	8,97	8,97	8,97	8,97	8,97	8,97	8,97	8,97	8,97	0,00
CYMCW	3,53	3,53	3,53	3,53	3,53	3,53	3,53	3,53	3,53	3,53	3,53	3,53	3,53	3,53	3,53	0,00
Total p.a.	203,93	235,30	145,30	235,30	263,80	145,30	235,30	235,30	173,80	249,12	235,30	145,30	263,80	235,30	145,30	90,00
NPV factor	1,00	0,91	0,83	0,75	0,68	0,62	0,56	0,51	0,47	0,42	0,39	0,35	0,32	0,29	0,26	0,24
NPV	203,93	213,91	120,08	176,79	180,18	90,22	132,82	120,75	81,08	105,65	90,72	50,93	84,06	68,16	38,26	21,55

Discount rate	10,00 %
----------------------	----------------

Sum of cash flow	3 237,5
-------------------------	----------------

Sum of NPV	1 779,1
-------------------	----------------

IEC 723/04

Figure C.5 – Net present value (10 % discount rate)

Figure C.5 shows that the net present value is a result of discounting the future cash flows by investing the "per year" sum until it is required and then reducing the sum by the return on the investment. By investing the capital until it is required, a saving of CU (3 237,5 – 1 779,1) = CU 1 458,4 over the O&M phase is achieved. If a return of only 5 % was possible, then the saving would only be CU (3 237,5 – 2 332,8) = CU 914,7 as shown in Figure C.6.

Year	0	1	2	3	4	5	6	7	8	9	10	11	12	13	14	15
CIMSRU	23,63	0,00	0,00	0,00	0,00	0,00	0,00	0,00	0,00	0,00	0,00	0,00	0,00	0,00	0,00	0,00
CIMFS	5,00	0,00	0,00	0,00	0,00	0,00	0,00	0,00	0,00	0,00	0,00	0,00	0,00	0,00	0,00	0,00
CIMFW	30,00	0,00	0,00	0,00	0,00	0,00	0,00	0,00	0,00	0,00	0,00	0,00	0,00	0,00	0,00	0,00
CYOL	50,00	50,00	50,00	50,00	50,00	50,00	50,00	50,00	50,00	50,00	50,00	50,00	50,00	50,00	50,00	0,00
CYOS	0,00	90,00	0,00	90,00	90,00	0,00	90,00	90,00	0,00	90,00	90,00	0,00	90,00	90,00	0,00	90,00
CYUO	82,80	82,80	82,80	82,80	82,80	82,80	82,80	82,80	82,80	82,80	82,80	82,80	82,80	82,80	82,80	0,00
CYMPBAT	0,00	0,00	0,00	0,00	28,50	0,00	0,00	0,00	28,50	0,00	0,00	0,00	28,50	0,00	0,00	0,00
CYMPFAN	0,00	0,00	0,00	0,00	0,00	0,00	0,00	0,00	0,00	13,82	0,00	0,00	0,00	0,00	0,00	0,00
CYMCS	8,97	8,97	8,97	8,97	8,97	8,97	8,97	8,97	8,97	8,97	8,97	8,97	8,97	8,97	8,97	0,00
CYMCW	3,53	3,53	3,53	3,53	3,53	3,53	3,53	3,53	3,53	3,53	3,53	3,53	3,53	3,53	3,53	0,00

Total	203,93	235,30	145,30	235,30	263,80	145,30	235,30	235,30	173,80	249,12	235,30	145,30	263,80	235,30	145,30	90,00
NPV factor	1,00	0,95	0,91	0,86	0,82	0,78	0,75	0,71	0,68	0,64	0,61	0,58	0,56	0,53	0,51	0,48
NPV	203,93	224,10	131,79	203,26	217,03	113,85	175,59	167,22	117,64	160,59	144,46	84,96	146,89	124,79	73,39	43,29

Discount rate	5,00 %
---------------	--------

Sum of cash flow	3 237,5
------------------	---------

Sum of NPV	2 332,8
------------	---------

Figure C.6 – Net present value (5 % discount rate)

IEC 724/04

Year	0	1	2	3	4	5	6	7	8	9	10	11	12	13	14	15
CIMSRU	22,67	0,00	0,00	0,00	0,00	0,00	0,00	0,00	0,00	0,00	0,00	0,00	0,00	0,00	0,00	0,00
CIMFS	5,00	0,00	0,00	0,00	0,00	0,00	0,00	0,00	0,00	0,00	0,00	0,00	0,00	0,00	0,00	0,00
CIMFW	30,00	0,00	0,00	0,00	0,00	0,00	0,00	0,00	0,00	0,00	0,00	0,00	0,00	0,00	0,00	0,00
CYOL	50,00	50,00	50,00	50,00	50,00	50,00	50,00	50,00	50,00	50,00	50,00	50,00	50,00	50,00	50,00	0,00
CYOS	0,00	90,00	0,00	90,00	90,00	0,00	90,00	90,00	0,00	90,00	90,00	0,00	90,00	90,00	0,00	90,00
CYUO	77,48	77,48	77,48	77,48	77,48	77,48	77,48	77,48	77,48	77,48	77,48	77,48	77,48	77,48	77,48	0,00
CYMPBAT	0,00	0,00	0,00	0,00	28,50	0,00	0,00	0,00	28,50	0,00	0,00	0,00	28,50	0,00	0,00	0,00
CYMPFAN	0,00	0,00	0,00	0,00	0,00	0,00	0,00	0,00	0,00	13,82	0,00	0,00	0,00	0,00	0,00	0,00
CYMCS	8,97	8,97	8,97	8,97	8,97	8,97	8,97	8,97	8,97	8,97	8,97	8,97	8,97	8,97	8,97	0,00
CYMCW	3,53	3,53	3,53	3,53	3,53	3,53	3,53	3,53	3,53	3,53	3,53	3,53	3,53	3,53	3,53	0,00

Total p.a.	197,65	229,98	139,98	229,98	258,48	139,98	229,98	229,98	168,48	243,80	229,98	139,98	258,48	229,98	139,98	90,00
NPV factor	1,00	0,95	0,91	0,86	0,82	0,78	0,75	0,71	0,68	0,64	0,61	0,58	0,56	0,53	0,51	0,48
NPV	197,65	219,03	126,97	198,67	212,65	109,68	171,62	163,44	114,04	157,16	141,19	81,84	143,93	121,96	70,70	43,29

Discount rate	5,00 %
---------------	--------

Sum of cash flow CU 000's	3 156,7
---------------------------	---------

Sum of NPV CU 000's	2 273,8
---------------------	---------

Figure C.7 – NPV with improved data store reliability (5 % discount rate)

IEC 725/04

Annex D (informative)

Examples of LCC model development

D.1 General

This annex presents simplified examples of life cycle cost model development and illustrates possible ways to identify cost elements. The examples are not complete and are intended to give only an idea regarding different modelling methods available.

In Clause D.2, an LCC model based on the six major life cycle phases is illustrated. LCC is then calculated by adding the different costs for each life cycle phase.

The example in Clause D.3 illustrates an LCC model where LCC at level one is divided into acquisition cost and cost of ownership.

D.2 LCC model based on costs for the life cycle phases

NOTE The model in this example is developed by adding the costs for the different life cycle phases of a new product.

D.2.1 First level breakdown

Life cycle cost is given by:

$$LCC = C_{CD} + C_{DD} + C_M + C_I + C_{OM} + C_D$$

where

LCC is the life cycle cost;

C_{CD} is the cost of concept and definition phase;

C_{DD} is the cost of design and development phase;

C_M is the cost of manufacturing phase;

C_I is the cost of installation phase;

C_{OM} is the cost of operation and maintenance phase;

C_D is the cost of disposal phase.

D.2.2 Second level breakdown

D.2.2.1 Concept and definition (C_{CD})

The cost of concept and definition phase, C_{CD} is given by:

$$C_{CD} = C_{CDR} + C_{CDM} + C_{CDA} + C_{CDS}$$

where

C_{CDR} is the cost for market research;

C_{CDM} is the cost for project management;

C_{CDA} is the cost for system concept and design analysis;

C_{CDS} is the cost for requirement specification.

D.2.2.2 Design and development phase (C_{DD})

The cost of the design and development phase C_{DD} is given by:

$$C_{DD} = C_{DDM} + C_{DDE} + C_{DDD} + C_{DDT} + C_{DDS} + C_{DDP} + C_{DDV} + C_{DDQ} + C_{DDR} + C_{DDI} + C_{DDL}$$

where

C_{DDM} is the cost for project management;

C_{DDE} is the cost for design engineering;

C_{DDD} is the cost for design documentation;

C_{DDT} is the cost for testing, evaluation and validation;

C_{DDS} is the cost for software development;

C_{DDP} is the cost for producibility engineering and planning;

C_{DDV} is the cost for vendor selection;

C_{DDQ} is the cost for quality management;

C_{DDR} is the cost for risk analysis;

C_{DDI} is the cost for environmental impact analysis;

C_{DDL} is the cost for logistics development.

D.2.2.3 Manufacturing phase (C_M)

The cost of the manufacturing phase C_M is given by:

$$C_M = C_{MN} + C_{MR}$$

where

C_{MN} is the cost for manufacturing, non-recurring;

C_{MR} is the total cost for manufacturing, recurring.

D.2.2.4 Installation phase (C_I)

The cost of the installation phase C_I is given by:

$$C_I = C_{IN} + C_{IR}$$

where

C_{IN} is the cost for installation, non-recurring;

C_{IR} is the cost for installation, recurring.

D.2.2.5 Operation and maintenance phase (C_{OM})

The cost of the operation and maintenance phase C_{OM} is given by:

$$C_{OM} = C_{OMO} + C_{OMC} + C_{OMP} + C_{OMV}$$

where

C_{OMO} is the cost for operation;

C_{OMC} is the cost for corrective maintenance;

C_{OMP} is the cost for preventive maintenance;

C_{OMV} is the cost for upgrading.

NOTE Significant investment costs can be incurred with upgrades.

For the calculation of C_{OMO} and C_{OMC} , see D.2.3.1.

D.2.2.6 Disposal phase (C_D)

The cost of the disposal phase C_D is given by:

$$C_D = C_{DS} + C_{DD} + C_{DR}$$

where

C_{DS} is the cost for system shutdown;

C_{DD} is the cost for disassembly and removal;

C_{DR} is the cost for recycling or safe disposal.

D.2.3 Third level breakdown

NOTE As an example of third level breakdown, the costs for the operation and maintenance phase are given below.

D.2.3.1 Operation and maintenance phase

D.2.3.1.1 Operation cost

The operation cost C_{OMO} is given by:

$$C_{OMO} = C_{OMOL} + C_{OMOM} + C_{OMOP} + \dots$$

where

C_{OMOL} is the cost for labour;

C_{OMOM} is the cost for material and consumables;

C_{OMOP} is the cost for power, etc.

D.2.3.1.2 Corrective maintenance cost

The corrective maintenance cost C_{OMC} is given by:

$$C_{OMC} = C_{OMCL} + C_{OMCF} + C_{OMCC} + C_{OMCS}$$

where

C_{OMCL} is the cost for labour;

C_{OMCF} is the cost for facilities;

C_{OMCC} is the cost for contractor services;

C_{OMCS} is the cost for software maintenance, etc.

Costs of replacement parts, shipping, and loss of function may be added here. Even elements for credit of returnables may be included.

D.3 LCC model based on acquisition cost and ownership cost

D.3.1 General

In this example, a subset of the life cycle cost elements is addressed.

It should be noted that the model is not complete, it is just an illustration of how an LCC model may be structured and how the costs associated with some of the different cost elements may be calculated. For some parts, the cost breakdown structure is presented down to the lowest desirable level and for other parts, just the intention is indicated.

If it is desirable to compare all costs at the same base date, the present value method may be used.

Please note that this is an example and that all cost elements may not be required and that others may have to be added.

D.3.2 Hierarchical structure

The hierarchical structure is shown in Figure D.1.

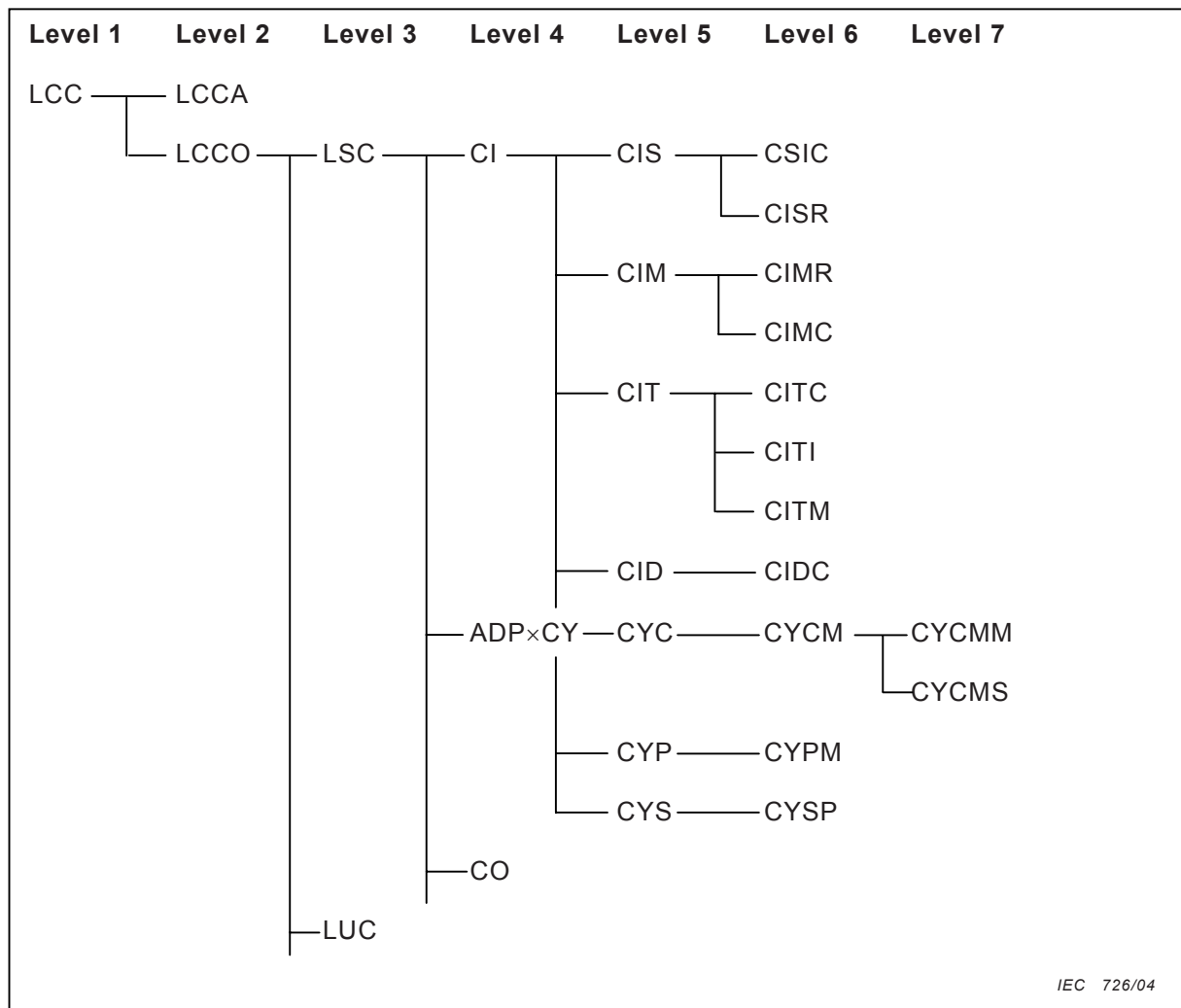

Figure D.1 – Hierarchical structure

D.3.3 Cost elements level 1 to 7

D.3.3.1 Level 1 costs

Life cycle cost, LCC, is given by

$$LCC = LCCA + LCCO$$

where

LCC is the life cycle cost as defined for this model;

LCCA is the acquisition cost (investment cost of resources for operation and maintenance support excluded);

LCCO is the ownership cost.

D.3.3.2 Level 2 costs**D.3.3.2.1 Life cycle cost, acquisition, LCCA**

LCCA is the acquisition cost where the investment cost of resources for operation and maintenance support is excluded.

D.3.3.2.2 Life cycle cost, ownership, LCCO

$$\text{LCCO} = \text{LSC} + \text{LCU}$$

where

LSC is the support cost over the product life;

LCU is the unavailability cost over the product life.

D.3.3.3 Level 3 costs**D.3.3.3.1 Life support cost, LSC**

$$\text{LSC} = \text{CI} + (\text{ADP} \times \text{CY}) + \text{CO}$$

where

LSC is the support cost over the product life;

CI is the cost for investment in maintenance support resources;

CY is the cost for maintenance, per annum;

ADP is the application factor to consider the number of years and interest to be used;

CO is the cost for operation.

D.3.3.4 Level 4 costs (examples)**D.3.3.4.1 Cost for investment**

Cost for investment in maintenance resources, CI, is given by:

$$\text{CI} = \text{CIS} + \text{CIM} + \text{CIT} + \text{CID}$$

where

CIS is the cost for investment in spares;

CIM is the cost for investment in maintenance equipment, instruments and tools;

CIT is the cost for investment in training;

CID is the cost for investment in documentation.

D.3.3.4.2 Cost for operation

Operating cost, CO, may be calculated by considering the following cost elements as appropriate:

- energy consumption cost;
- person hour cost;
- material consumption cost;
- etc.

For costs that will be constant through their lifetime, the annual cost may be multiplied with a discount factor f to obtain the cost over the lifetime.

$$f = \frac{1}{(1+r)^{t_1-t_0}} \sum_{t=1}^m \frac{1}{(1+r)^t}$$

where

- t_0 is the base year for the evaluation;
- t_1 is the time for start up of operations;
- m is the number of years in operation;
- r is the discount rate to be used for the evaluation.

D.3.3.5 Level 5 costs (examples)

Cost of investment in maintenance equipment, CIM, is given by:

$$\text{CIM} = (\text{NC} \times \text{CIMC}) + (\text{NR} \times \text{CIMR})$$

where

- CIMC is the cost for investment in maintenance equipment for a central workshop;
- CIMR is the cost for investment in maintenance equipment for a regional workshop;
- NC is the number of central workshops;
- NR is the number of regional workshops.

D.3.3.6 Level 6 costs (examples)

3.3.6.1 Cost elements level 6

- CISC is the cost for investment in repairable units at central level;
- CISR is the cost for investment in repairable units at regional level;
- CIMR is the cost for investment in maintenance equipment for all regional workshops;
- CIMC is the cost for investment in maintenance equipment, tools, lifting aids, etc. for the central workshop;
- CITC is the cost for investment in training at central level;
- CITI is the cost for investment in instructions;
- CITM is the cost for investment in training material;
- CIDC is the cost for investment in documentation;
- CYCM is the annual cost, corrective maintenance;
- CYPM is the annual cost, preventive maintenance;
- CYSP is the annual cost for the consumption of spare parts.

3.3.6.2 Cost for investment

Cost for investment in maintenance equipment for a central workshop, CIMC, is given by:

$$\text{CIMC} = \text{APV} \times \sum_{J1=1}^M \text{NMC}(J1) \times \text{CSMC}(J1)$$

where

APV is the application factor due to possible existence of price variation clauses related to contractor and investment;

M is the number of different types of maintenance aids needed at the central workshop;

NMC($J1$) is the number of maintenance aids of type $J1$ at central workshop;

CSMC($J1$) is the unit cost for maintenance aid of type $J1$.

3.3.6.3 Annual costs, corrective maintenance, CYCM

$$\text{CYCM} = \text{CYCMM} + \text{CYCMS}$$

where

CYCMM is the average annual corrective maintenance person hour cost;

CYCMS is the cost for spare parts consumption.

To calculate CYCMM, the following formula may be used:

$$\text{CYCMM} = \lambda_T \times 8\,760 \times \text{MRT} \times P \times M$$

where

OYCCM is the zero-setting constant for this equation;

CYCMM is the average annual person hour cost for corrective maintenance;

λ_T is the total failure rate as number of failures per hour. This includes all failures;

8 760 is the number of hours in a year;

MRT is the mean repair time, the time in hours it takes to restore a faulty item back to operating conditions;

P is the number of persons required to do the work;

M is the person hour rate.

The average annual costs may be discounted as shown below.

The base year for the analysis is established. All costs are then discounted back to this base year to take into account the time value of money. For this, the following formula is applied:

$$\sum_{t=0}^n \frac{S_t}{(1+k)^t}$$

where

S_t is the net cost in year t . This can be assumed equal for all the years, it can vary according to production, or it can have some other given variation throughout the lifetime;

n is the lifetime of the equipment/ function to be evaluated. When the required lifetime of the equipment exceeds the expected lifetime, the required life is used;

k is the discount rate/interest rate to be used for the evaluation.

$$\text{CYCMS} = \lambda_T \times 8\,760 \times \text{average spares cost:}$$

where

λ_T is the total failure rate as number of failures per hour. This includes all failures;

8 760 is the number of hours in a year.

Annex E (informative)

Example of a product breakdown structure and LCC summary for a railway vehicle

Railway operators around the world are increasingly applying life cycle costing to assist in the choice between tenders for the supply of rolling stock and fixed installation equipment. The example illustrates a product breakdown structure (PBS) for a rail vehicle that is used as the basis for an LCC model for the fleet of multiple units to be procured.

For each item of vehicle equipment specified within the generic PBS (see Figure E.1), LCC data (by cost category) are provided by suppliers for their respective equipment, in a spreadsheet format, for input to the LCC model. The LCC model contains details of the fleet, multiple unit and equipment used in each vehicle of the multiple unit. It also contains the labour and overhead rates and power consumption usage and costs specific to the territory where the vehicles will be operated and maintained.

The LCC model is designed to produce various reports for a variety of purposes. Table E.1 is a high-level summary that illustrates the distribution of the costs by PBS and the various cost categories.

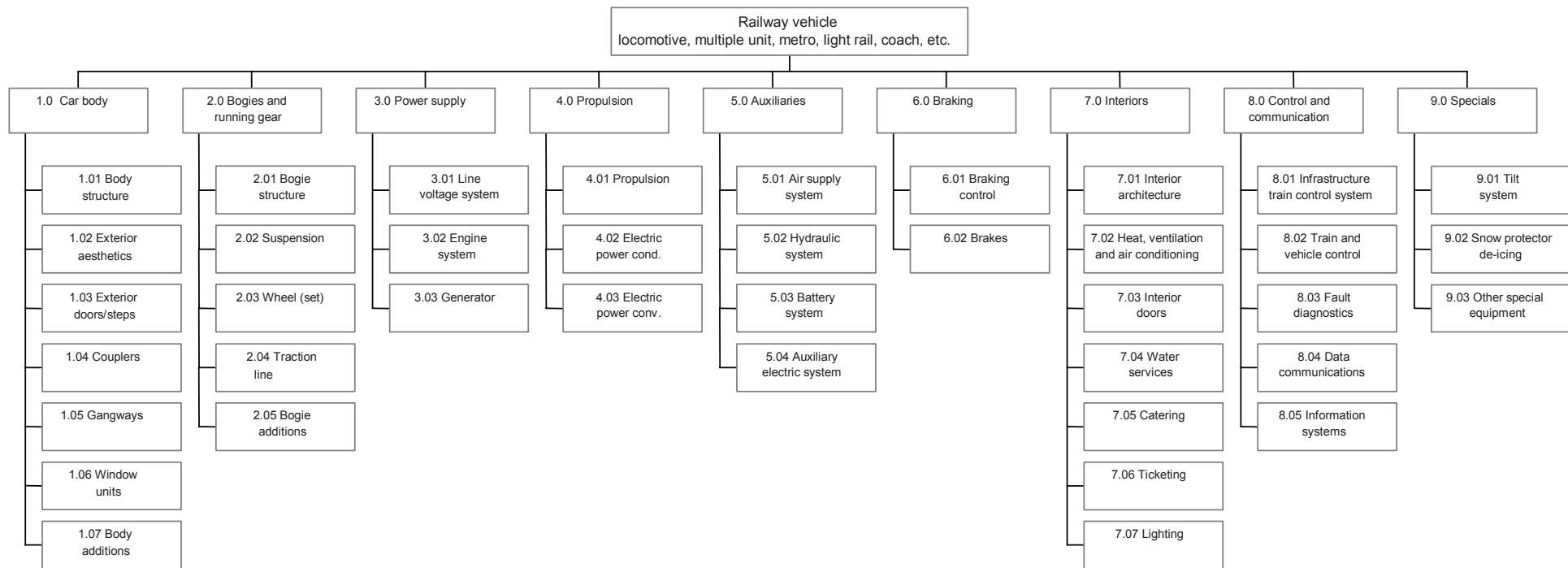

IEC 727/04

Figure E.1 – Vehicle system product breakdown structure

Table E.1 – Life cycle cost summary by product breakdown structure

WBS ref.	System description	Acquisition costs	Spares	Special tools	Scheduled maint. labour	Scheduled maint. material	Scheduled maint. total	Non-scheduled maint. labour	Non-scheduled maint. material	Non-scheduled maint. total	Total life cycle cost	Percentage life cycle cost %
1.0	Car body	51 781			5 471	24 716	30 187	208	4 587	4 795	86 763	73
2.0	Bogies and running gear	5 820			25	0	25	0	0	0	5 845	5
3.0	Power supply	5 811			3	0	3	0	0	0	5 814	5
4.0	Propulsion	3 399			2118	2 974	5 092	54	595	649	9 140	8
5.0	Auxiliaries	1 975			0	0	0	0	13	13	1988	2
6.0	Braking	487			56	438	494	0	0	0	981	1
7.0	Interiors	0			0	0	0	0	0	0	0	0
8.0	Control and communication	7 151			361	412	773	3	7	10	7 934	7
9.0	Specials											
	Totals	76 424	0	0	8034	28 540	36 574	265	5 202	5 467	118 465	100

NOTE: All costs are in CUs.

Annex ZA (normative)

Normative references to international publications with their corresponding European publications

The following referenced documents are indispensable for the application of this document. For dated references, only the edition cited applies. For undated references, the latest edition of the referenced document (including any amendments) applies.

NOTE Where an international publication has been modified by common modifications, indicated by (mod), the relevant EN/HD applies.

<u>Publication</u>	<u>Year</u>	<u>Title</u>	<u>EN/HD</u>	<u>Year</u>
IEC 60050-191	1990	International Electrotechnical Vocabulary (IEV) Chapter 191: Dependability and quality of service	-	-
IEC 60300-3-12	- ¹⁾	Dependability management Part 3-12: Application guide - Integrated logistic support	EN 60300-3-12	2004 ²⁾
IEC 61703	- ¹⁾	Mathematical expressions for reliability, availability, maintainability and maintenance support terms	EN 61703	2002 ²⁾
IEC 62198	- ¹⁾	Project risk management - Application guidelines	-	-

1) Undated reference.

2) Valid edition at date of issue.

BSI — British Standards Institution

BSI is the independent national body responsible for preparing British Standards. It presents the UK view on standards in Europe and at the international level. It is incorporated by Royal Charter.

Revisions

British Standards are updated by amendment or revision. Users of British Standards should make sure that they possess the latest amendments or editions.

It is the constant aim of BSI to improve the quality of our products and services. We would be grateful if anyone finding an inaccuracy or ambiguity while using this British Standard would inform the Secretary of the technical committee responsible, the identity of which can be found on the inside front cover.
Tel: +44 (0)20 8996 9000. Fax: +44 (0)20 8996 7400.

BSI offers members an individual updating service called PLUS which ensures that subscribers automatically receive the latest editions of standards.

Buying standards

Orders for all BSI, international and foreign standards publications should be addressed to Customer Services. Tel: +44 (0)20 8996 9001.
Fax: +44 (0)20 8996 7001. Email: orders@bsi-global.com. Standards are also available from the BSI website at <http://www.bsi-global.com>.

In response to orders for international standards, it is BSI policy to supply the BSI implementation of those that have been published as British Standards, unless otherwise requested.

Information on standards

BSI provides a wide range of information on national, European and international standards through its Library and its Technical Help to Exporters Service. Various BSI electronic information services are also available which give details on all its products and services. Contact the Information Centre.
Tel: +44 (0)20 8996 7111. Fax: +44 (0)20 8996 7048. Email: info@bsi-global.com.

Subscribing members of BSI are kept up to date with standards developments and receive substantial discounts on the purchase price of standards. For details of these and other benefits contact Membership Administration.
Tel: +44 (0)20 8996 7002. Fax: +44 (0)20 8996 7001.
Email: membership@bsi-global.com.

Information regarding online access to British Standards via British Standards Online can be found at <http://www.bsi-global.com/bsonline>.

Further information about BSI is available on the BSI website at <http://www.bsi-global.com>.

Copyright

Copyright subsists in all BSI publications. BSI also holds the copyright, in the UK, of the publications of the international standardization bodies. Except as permitted under the Copyright, Designs and Patents Act 1988 no extract may be reproduced, stored in a retrieval system or transmitted in any form or by any means – electronic, photocopying, recording or otherwise – without prior written permission from BSI.

This does not preclude the free use, in the course of implementing the standard, of necessary details such as symbols, and size, type or grade designations. If these details are to be used for any other purpose than implementation then the prior written permission of BSI must be obtained.

Details and advice can be obtained from the Copyright & Licensing Manager.
Tel: +44 (0)20 8996 7070. Fax: +44 (0)20 8996 7553.
Email: copyright@bsi-global.com.