

Electric cables — Tests on extruded oversheaths with a special protective function

ICS 29.060.20

National foreword

This British Standard is the UK implementation of EN 60229:2008. It is identical to IEC 60229:2007.

The UK participation in its preparation was entrusted by Technical Committee GEL/20, Electric cables, to Subcommittee GEL/20/16, Medium/high voltage cables.

A list of organizations represented on this committee can be obtained on request to its secretary.

This publication does not purport to include all the necessary provisions of a contract. Users are responsible for its correct application.

Compliance with a British Standard cannot confer immunity from legal obligations.

This British Standard was published under the authority of the Standards Policy and Strategy Committee on 31 July 2008

© BSI 2008

ISBN 978 0 580 58061 1

Amendments/corrigenda issued since publication

Date	Comments

English version

**Electric cables -
Tests on extruded oversheaths with a special protective function
(IEC 60229:2007)**

Câbles électriques -
Essais sur les gaines extérieures
extrudées avec fonction spéciale
de protection
(CEI 60229:2007)

Starkstromkabel -
Prüfungen an extrudierten Außenmänteln
mit besonderer Schutzfunktion
(IEC 60229:2007)

This European Standard was approved by CENELEC on 2008-05-01. CENELEC members are bound to comply with the CEN/CENELEC Internal Regulations which stipulate the conditions for giving this European Standard the status of a national standard without any alteration.

Up-to-date lists and bibliographical references concerning such national standards may be obtained on application to the Central Secretariat or to any CENELEC member.

This European Standard exists in three official versions (English, French, German). A version in any other language made by translation under the responsibility of a CENELEC member into its own language and notified to the Central Secretariat has the same status as the official versions.

CENELEC members are the national electrotechnical committees of Austria, Belgium, Bulgaria, Cyprus, the Czech Republic, Denmark, Estonia, Finland, France, Germany, Greece, Hungary, Iceland, Ireland, Italy, Latvia, Lithuania, Luxembourg, Malta, the Netherlands, Norway, Poland, Portugal, Romania, Slovakia, Slovenia, Spain, Sweden, Switzerland and the United Kingdom.

CENELEC

European Committee for Electrotechnical Standardization
Comité Européen de Normalisation Electrotechnique
Europäisches Komitee für Elektrotechnische Normung

Central Secretariat: rue de Stassart 35, B - 1050 Brussels

Foreword

The text of the International Standard IEC 60229:2007, prepared by IEC TC 20, Electric cables, was submitted to the Unique Acceptance Procedure and was approved by CENELEC as EN 60229 on 2008-05-01 without any modification.

The following dates were fixed:

- latest date by which the EN has to be implemented at national level by publication of an identical national standard or by endorsement (dop) 2009-05-01
- latest date by which the national standards conflicting with the EN have to be withdrawn (dow) 2011-05-01

Annex ZA has been added by CENELEC.

Endorsement notice

The text of the International Standard IEC 60229:2007 was approved by CENELEC as a European Standard without any modification.

CONTENTS

1	Scope	4
2	Normative references	4
3	Routine tests	4
3.1	D.C. voltage test	5
3.2	Spark test	5
4	Type tests	5
4.1	Abrasion test	5
4.1.1	Purpose	5
4.1.2	Test procedure	5
4.1.3	Inspection	7
4.1.4	Performance requirement	7
4.2	Corrosion spread (aluminium metallic screen only)	7
4.2.1	General	7
4.2.2	Test procedure	7
4.2.3	Inspection	8
4.2.4	Performance requirement	8
5	Electrical test after installation	8
	Annex A (normative) Application of the abrasion test	9
	Annex B (informative) Guidance on tests after installation	10
	Annex ZA (normative) Normative references to international publications with their corresponding European publications	11
	Figure 1 – Abrasion test	6
	Table 1 – Vertical force on steel angle	6
	Table 2 – Impulse test voltage	7

ELECTRIC CABLES – TESTS ON EXTRUDED OVERSHEATHS WITH A SPECIAL PROTECTIVE FUNCTION

1 Scope

This International Standard provides a range of tests which may be required for electric cables which have an extruded oversheath and where that oversheath performs a special protective function.

NOTE 1 The need for the special functions may be independent of the nature of the insulation type or independent of the rated voltage of the cable.

The standard covers cables for use in insulated systems and in uninsulated systems.

The tests are categorized for use as

- a) routine tests,
- b) type tests,
- c) tests after installation.

These tests comprise:

- electrical routine tests on cable oversheath used in insulated or uninsulated systems,
- abrasion and corrosion spread type tests,
- electrical test on cable oversheath after installation.

Routine tests and tests after installation, as specified in the relevant cable standards, are applicable for all situations.

Type tests depend upon the nature of the system and the construction of the cable and do not have to be carried out for normal conditions of use.

The application of the abrasion test is given in Annex A.

NOTE 2 Guidance on tests after installation is given in Annex B.

2 Normative references

The following referenced documents are indispensable for the application of this document. For dated references, only the edition cited applies. For undated references, the latest edition of the referenced document (including any amendments) applies.

IEC 60230, *Impulse tests on cables and their accessories*

IEC 62230, *Electric cables – Spark test method*

3 Routine tests

The electrical integrity of the oversheath shall be tested using either a d.c. voltage test (3.1) or a spark test (3.2).

NOTE The spark test method is not applicable when a conducting layer is already applied to the oversheath. In such cases only the test according to 3.1 may be used.

Testing is applicable in all cases.

3.1 D.C. voltage test

A d.c. voltage of 8 kV per millimetre of the specified nominal thickness of the extruded oversheath shall be applied for 1 min between the underlying metal layer at negative polarity and the outer conducting layer, subject to a maximum voltage of 25 kV.

No breakdown of the oversheath shall occur during the test.

NOTE The outer conducting layer may consist of a conductive layer applied to the extruded oversheath or obtained by immersion in water for the duration of the test.

3.2 Spark test

A spark test according to the method given in IEC 62230 shall be carried out by earthing the underlying metallic layer for an a.c. test or connecting it to the negative pole in the case of a d.c. supply. The voltages shall be 6 kV a.c. per millimetre or 9 kV d.c. per millimetre of the specified nominal thickness of the extruded oversheath, subject to maximum values of 15 kV a.c. and 25 kV d.c., respectively.

The dwell time of the cable in the region of test shall be of sufficient duration to detect any defect.

No faults shall be detected during the test.

4 Type tests

4.1 Abrasion test

4.1.1 Purpose

The purpose of this test is to demonstrate that the extruded oversheath will withstand abrasion during the laying operation.

The abrasion test shall be carried out if the oversheath material is not of type ST1, ST2, ST3 or ST7 compound and if the thickness does not comply with the particular IEC cable standard.

4.1.2 Test procedure

A sample of the cable, of sufficient length, shall be submitted to the bending operation given in the bending test, as specified in the particular IEC cable standard.

After bending, the procedure specified in 4.1.2.1 shall be carried out at a temperature of (20 ± 5) °C for cases a) and b), as described in Annex A. This shall be followed by the electrical test in 4.1.2.2 for case a) only.

4.1.2.1 Abrasion

The sample of cable shall be laid out straight and horizontal on a firm base, with the plane of the previous bending operation in the horizontal plane. In the middle of the sample and perpendicular to it, a length of mild steel angle shall be placed horizontally, at right angles to the cable, with its angle edge resting on the cable and with its arms symmetrical about the vertical plane through the longitudinal axis of the cable. The outer radius of curvature of the angle edge shall be not less than 1 mm and not greater than 2 mm (see Figure 1).

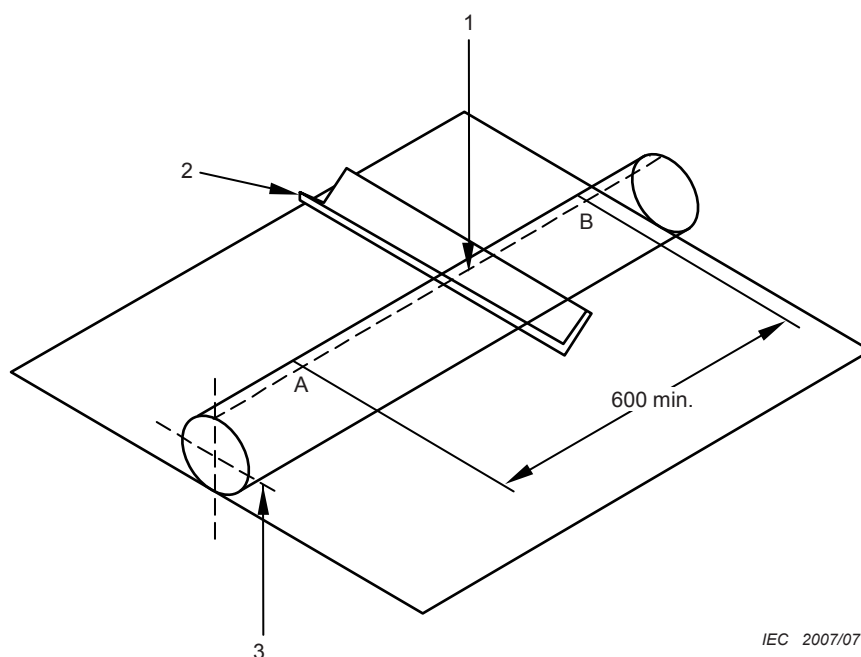

IEC 2007/07

Key

1	force (see Table 1)	A	start/finish position
2	mild steel angle	B	finish/start position
3	plane of bending	A-B	test path length (minimum)

Figure 1 – Abrasion test

The steel angle shall be vertically loaded, above the point of contact, with a force in accordance with Table 1.

The steel angle shall be dragged horizontally along the cable for a distance not less than 600 mm at a speed of between 150 mm/s and 300 mm/s. The direction of movement shall be reversed at the end of each pass to give 50 passes, 25 in each direction over the 600 mm test path.

Table 1 – Vertical force on steel angle

Overall measured diameter of cable mm		Force N
Above and including	Up to	
30	40	65
40	50	105
50	60	155
60	70	210
70	80	270
80	90	340
90	100	420
100	110	500
110 and above		550

4.1.2.2 Electrical test

The middle of the cable sample, conditioned as above, shall be submerged at ambient temperature in a 0,5 % by weight solution of sodium chloride in water containing approximately 0,1 % by weight of a suitable non-ionic surface active agent.

After at least 24 h of constant immersion, a d.c. voltage of 20 kV shall be applied for a period of 1 min between the saline solution and the underlying metal layer which shall be at negative polarity.

With the middle of the cable still submerged at ambient temperature in the sodium chloride solution, apply 10 positive, followed by 10 negative impulse voltages, in accordance with IEC 60230, and Table 2:

Table 2 – Impulse test voltage

Rated lightning impulse withstand voltage of main insulation voltage (peak) kV	Impulse test voltage (peak) kV
$V \leq 325$	30
$325 < V \leq 750$	37,5
$750 < V < 1\ 175$	47,5
$1\ 175 \leq V < 1\ 550$	62,5
$V \geq 1\ 550$	72,5

4.1.3 Inspection

The cable sample shall be taken (from the solution if test following 4.1.2.2 is performed) and a 1 m length, which includes the abraded area of the extruded oversheath, shall be removed, employing two longitudinal cuts which do not pass through the conditioned area. The test sample shall be cleaned of foreign material.

4.1.4 Performance requirement

The oversheaths shall be deemed satisfactory provided that

- a) the electrical test has been passed, where required, and
- b) an examination of the sample with normal or corrected vision without magnification reveals no cracks or splits in the internal and external surfaces.

4.2 Corrosion spread (aluminium metallic screen only)

4.2.1 General

The corrosion spread test is relevant in the case of aluminium wires, aluminium sheaths and aluminium foils when not bonded to the oversheath. It is not applicable in the case of aluminium sheaths or foils bonded to the oversheath.

The purpose is to demonstrate that, in the event of local damage to an oversheath, any consequential corrosion of the outer surface of the aluminium screen will remain virtually confined to the damaged area of covering.

4.2.2 Test procedure

- a) Bending operation

A sample of cable shall be submitted to the bending procedure of the bending test, as specified in the particular IEC cable standard.

b) Local damage

The oversheath shall be punctured down to the aluminium sheath or wires, in four places, by means of a core drill of 10 mm diameter. These four holes shall be arranged spirally about the mid-portion of the cable sample, at longitudinal intervals of about 100 mm and circumferential spacings of 90°. All material shall be removed from each hole to expose the 10 mm diameter of bare aluminium.

c) Corrosion procedure

The sample shall be formed into a U-shape with the curved portion having a radius of curvature not greater than specified in the bending operation above. The curved portion shall be submerged in a 1 % solution of sodium sulphate in water at ambient temperature, with the cable ends in the air. All four holes shall be submerged to a depth of at least 500 mm in the solution. With a d.c. voltage applied between the metallic screen and the solution and with metallic screen at negative polarity, a current of 10 mA shall flow for a total period of (100 ± 2) h. This value of current shall be maintained substantially constant. This may be achieved by the inclusion of a series resistor, resistance value of about 10 k Ω , in the electrical circuit. If two or more samples are electrically tested simultaneously, each sample shall be independently controlled (for example by being connected through its own series resistor).

4.2.3 Inspection

The cable sample shall be taken from the solution and the oversheath removed for a length of about 500 mm, extending to at least 100 mm beyond each of the outer holes. All other material in this region shall be removed from the metallic screen to expose bare aluminium.

4.2.4 Performance requirement

The oversheath shall be deemed satisfactory provided that, by examination with normal or corrected vision without magnification, there are no signs of corrosion extending more than 10 mm beyond the rim of any hole at any point.

5 Electrical test after installation

Where an 'after installation' test of the oversheath is performed, a d.c. voltage of 4 kV per millimetre of specified thickness of extruded oversheath shall be applied with a maximum of 10 kV d.c. between the underlying metallic layers and the outer electrode, for a period of 1 min. All metallic layers under the oversheath shall be connected together.

This test requires that the oversheath has an outer "electrode" which may be moist backfill or a conductive layer.

No breakdown of the oversheath shall occur during the test.

Annex A
(normative)

Application of the abrasion test

A.1 Case a) where the oversheath is to act as an insulation:

- i) where special metallic screen bonding is employed to reduce metallic sheath or screen losses, resulting in an applied voltage to the oversheath under load and fault conditions;
- ii) where the underlying metallic layer can be isolated from earth to permit a voltage to be applied to the oversheath to check its integrity.

A.2 Case b) where the oversheath is to act as an improved protection against corrosion:

- i) where protection of the metallic layer is of significant importance;
- ii) where the combination of the particular metal and the cable environment would give rise to a serious risk of corrosion;
- iii) where corrosion, plus the ingress of water, could result in degradation of the cable insulation system.

Annex B (informative)

Guidance on tests after installation

Both before and after installation, testing of cable sheaths which have a conductive coating is being performed more frequently. These tests are often performed on the drum of cable before installation, as well as after installation, as part of the commissioning tests.

In recognition of this, and to ensure that those conducting these tests do so in a safe and responsible manner, Annex B: Guidance on testing after installation, is included and the following points should be taken into consideration:

1. The conducting layer should be removed from the cable ends to prevent any tracking/flashover when the test is being conducted.
 2. It should be noted that the use of some solvents and cleaners to remove the conducting layer may have a detrimental effect on the physical properties of the oversheath material.
 3. The conducting layer must be adequately earthed when the test is being performed.
 4. Steps should be taken to avoid a charge build-up in other metallic components within the cable and surrounding metallic objects during the test (all metallic layers under the oversheath shall be connected together).
 5. Safety protocols should ensure restricted access to the test site when the test is being conducted.
 6. Upon completion of the test, the cable should be earthed for a suitable period following the test to ensure any residual charge is removed.
 7. The value of the test current may be taken for engineering information only.
-

Annex ZA
(normative)

**Normative references to international publications
with their corresponding European publications**

The following referenced documents are indispensable for the application of this document. For dated references, only the edition cited applies. For undated references, the latest edition of the referenced document (including any amendments) applies.

NOTE Where an International Publication has been modified by common modifications, indicated by (mod), the relevant EN/HD applies.

<u>Publication</u>	<u>Year</u>	<u>Title</u>	<u>EN/HD</u>	<u>Year</u>
IEC 60230	- ¹⁾	Impulse tests on cables and their accessories	EN 60230	2002 ²⁾
IEC 62230	- ¹⁾	Electric cables - Spark-test method	EN 62230	2007 ²⁾

1) Undated reference.

2) Valid edition at date of issue.

British Standards Institution (BSI)

BSI is the independent national body responsible for preparing British Standards. It presents the UK view on standards in Europe and at the international level. It is incorporated by Royal Charter.

Revisions

British Standards are updated by amendment or revision. Users of British Standards should make sure that they possess the latest amendments or editions.

It is the constant aim of BSI to improve the quality of our products and services. We would be grateful if anyone finding an inaccuracy or ambiguity while using this British Standard would inform the Secretary of the technical committee responsible, the identity of which can be found on the inside front cover.
Tel: +44 (0)20 8996 9000 Fax: +44 (0)20 8996 7400

BSI offers members an individual updating service called PLUS which ensures that subscribers automatically receive the latest editions of standards.

Buying standards

Orders for all BSI, international and foreign standards publications should be addressed to Customer Services.

Tel: +44 (0)20 8996 9001 Fax: +44 (0)20 8996 7001

Email: orders@bsigroup.com

You may also buy directly using a debit/credit card from the BSI Shop on the Website <http://www.bsigroup.com/shop>.

In response to orders for international standards, it is BSI policy to supply the BSI implementation of those that have been published as British Standards, unless otherwise requested.

Information on standards

BSI provides a wide range of information on national, European and international standards through its Library and its Technical Help to Exporters Service. Various BSI electronic information services are also available which give details on all its products and services. Contact the Information Centre.

Tel: +44 (0)20 8996 7111 Fax: +44 (0)20 8996 7048

Email: info@bsigroup.com

Subscribing members of BSI are kept up to date with standards developments and receive substantial discounts on the purchase price of standards. For details of these and other benefits contact Membership Administration.

Tel: +44 (0)20 8996 7002 Fax: +44 (0)20 8996 7001

Email: membership@bsigroup.com

Information regarding online access to British Standards via British Standards Online can be found at <http://www.bsigroup.com/BSOL>.

Further information about BSI is available on the BSI website at <http://www.bsigroup.com>.

Copyright

Copyright subsists in all BSI publications. BSI also holds the copyright, in the UK, of the publications of the international standardization bodies. Except as permitted under the Copyright, Designs and Patents Act 1988 no extract may be reproduced, stored in a retrieval system or transmitted in any form or by any means – electronic, photocopying, recording or otherwise – without prior written permission from BSI.

This does not preclude the free use, in the course of implementing the standard, of necessary details such as symbols, and size, type or grade designations. If these details are to be used for any other purpose than implementation then the prior written permission of BSI must be obtained.

Details and advice can be obtained from the Copyright & Licensing Manager.

Tel: +44 (0)20 8996 7070 Email: copyright@bsigroup.com