

BS EN 60214-1:2014



BSI Standards Publication

Tap-changers

Part 1: Performance requirements
and test methods

bsi.

...making excellence a habit.™

National foreword

This British Standard is the UK implementation of EN 60214-1:2014. It is identical to IEC 60214-1:2014. It supersedes BS EN 60214-1:2003 which is withdrawn.

The UK participation in its preparation was entrusted to Technical Committee PEL/14, Power transformers.

A list of organizations represented on this committee can be obtained on request to its secretary.

This publication does not purport to include all the necessary provisions of a contract. Users are responsible for its correct application.

© The British Standards Institution 2014.

Published by BSI Standards Limited 2014

ISBN 978 0 580 79303 5

ICS 29.180

Compliance with a British Standard cannot confer immunity from legal obligations.

This British Standard was published under the authority of the Standards Policy and Strategy Committee on 30 September 2014.

Amendments/corrigenda issued since publication

Date	Text affected
-------------	----------------------

English Version

**Tap-changers - Part 1: Performance requirements and test
methods
(IEC 60214-1:2014)**

Changeurs de prises - Partie 1: Prescriptions de
performances et méthodes d'essai
(CEI 60214-1:2014)

Stufenschalter - Teil 1: Leistungsanforderungen und
Prüfverfahren
(IEC 60214-1:2014)

This European Standard was approved by CENELEC on 2014-06-26. CENELEC members are bound to comply with the CEN/CENELEC Internal Regulations which stipulate the conditions for giving this European Standard the status of a national standard without any alteration.

Up-to-date lists and bibliographical references concerning such national standards may be obtained on application to the CEN-CENELEC Management Centre or to any CENELEC member.

This European Standard exists in three official versions (English, French, German). A version in any other language made by translation under the responsibility of a CENELEC member into its own language and notified to the CEN-CENELEC Management Centre has the same status as the official versions.

CENELEC members are the national electrotechnical committees of Austria, Belgium, Bulgaria, Croatia, Cyprus, the Czech Republic, Denmark, Estonia, Finland, Former Yugoslav Republic of Macedonia, France, Germany, Greece, Hungary, Iceland, Ireland, Italy, Latvia, Lithuania, Luxembourg, Malta, the Netherlands, Norway, Poland, Portugal, Romania, Slovakia, Slovenia, Spain, Sweden, Switzerland, Turkey and the United Kingdom.



European Committee for Electrotechnical Standardization
Comité Européen de Normalisation Electrotechnique
Europäisches Komitee für Elektrotechnische Normung

CEN-CENELEC Management Centre: Avenue Marnix 17, B-1000 Brussels

Foreword

The text of document 14/746/CDV, future edition 2 of IEC 60214-1, prepared by IEC/TC 14 "Power transformers" was submitted to the IEC-CENELEC parallel vote and approved by CENELEC as EN 60214-1:2014.

The following dates are fixed:

- latest date by which the document has to be implemented at national level by publication of an identical national standard or by endorsement (dop) 2015-03-26
- latest date by which the national standards conflicting with the document have to be withdrawn (dow) 2017-06-26

This document supersedes EN 60214-1:2003.

Attention is drawn to the possibility that some of the elements of this document may be the subject of patent rights. CENELEC [and/or CEN] shall not be held responsible for identifying any or all such patent rights.

Endorsement notice

The text of the International Standard IEC 60214-1:2014 was approved by CENELEC as a European Standard without any modification.

In the official version, for Bibliography, the following notes have to be added for the standards indicated:

IEC 60076-1:2011	NOTE	Harmonized in EN 60076-1:2011.
IEC 60076-11	NOTE	Harmonized as EN 60076-11.
IEC 60376	NOTE	Harmonized as EN 60376.
IEC 60599	NOTE	Harmonized as EN 60599.

Annex ZA (normative)

Normative references to international publications with their corresponding European publications

The following documents, in whole or in part, are normatively referenced in this document and are indispensable for its application. For dated references, only the edition cited applies. For undated references, the latest edition of the referenced document (including any amendments) applies.

NOTE 1 When an International Publication has been modified by common modifications, indicated by (mod), the relevant EN/HD applies.

NOTE 2 Up-to-date information on the latest versions of the European Standards listed in this annex is available here: www.cenelec.eu.

<u>Publication</u>	<u>Year series</u>	<u>Title</u>	<u>EN/HD</u>	<u>Year series</u>
IEC 60050		International Electrotechnical Vocabulary -- Electrical and electronic measurements and measuring		
IEC 60060-1	-	High-voltage test techniques -- Part 1:EN 60060-1 General definitions and test requirements		-
IEC 60076-3	2013	Power transformers -- Part 3: Insulation levels, dielectric tests and external clearances in air	EN 60076-3	2013
IEC 60076-7	2005	Power transformers -- Part 7: Loading- guide for oil-immersed power transformers		-
IEC 60076-21	2011		-	-
IEC 60137	2008	Insulated bushings for alternating voltages above 1 000 V	EN 60137	2008
IEC 60214-2	2004	Tap changers -- Part 2: Application guide	-	-
IEC 60270	-	High-voltage test techniques - Partial discharge measurements	EN 60270	-
IEC 60296	-	Fluids for electrotechnical applications - Unused mineral insulating oils for transformers and switchgear	EN 60296	-
IEC 60529	-	Degrees of protection provided by- enclosures (IP Code)		-

CONTENTS

1	Scope	8
2	Normative references	8
3	Terms and definitions	9
4	Service conditions	15
4.1	Temperature of tap-changer environment.....	15
4.2	Temperature of motor-drive mechanism environment.....	16
4.3	Overload conditions	16
5	Requirements for on-load tap-changers	16
5.1	General requirements	16
5.1.1	Rating.....	16
5.1.2	Compartments for diverter and selector switches	17
5.1.3	Liquid-level gauges and gas monitoring devices	17
5.1.4	Safety requirements for protection against internal failure.....	17
5.1.5	Limiting devices for the protection against transient overvoltages	18
5.1.6	Change-over selector recovery voltages	18
5.1.7	Leakage inductance in coarse fine regulation arrangements	18
5.2	Type tests	18
5.2.1	General	18
5.2.2	Temperature rise of contacts	19
5.2.3	Switching tests	20
5.2.4	Short-circuit current test	25
5.2.5	Transition impedance test.....	26
5.2.6	Mechanical tests.....	27
5.2.7	Tightness test.....	29
5.2.8	Dielectric tests.....	30
5.2.9	Type-test certificate	35
5.3	Routine tests	35
5.3.1	General	35
5.3.2	Mechanical test	35
5.3.3	Sequence test	35
5.3.4	Auxiliary circuits insulation test.....	35
5.3.5	Pressure and vacuum tests.....	35
6	Requirements for motor-drive mechanisms for on-load tap-changers	35
6.1	General requirements	35
6.1.1	Compliance of component parts.....	35
6.1.2	Permissible variation of auxiliary supply	36
6.1.3	Step-by-step control	36
6.1.4	Tap position indicator	36
6.1.5	Tap-change in progress indication	36
6.1.6	Limiting devices.....	36
6.1.7	Parallel control devices.....	36
6.1.8	Direction of rotation protection.....	36
6.1.9	Overcurrent blocking device	36
6.1.10	Restarting device.....	37
6.1.11	Operation counter.....	37

6.1.12	Manual operation of the motor-drive mechanism	37
6.1.13	Motor-drive cubicle	37
6.1.14	Protective device against running-through	37
6.1.15	Protection against access to hazardous parts	37
6.2	Type tests	37
6.2.1	Mechanical load test	37
6.2.2	Overrun test	38
6.2.3	Degree of protection of motor-drive cubicle.....	38
6.3	Routine tests	38
6.3.1	Mechanical tests.....	38
6.3.2	Auxiliary circuits insulation test.....	38
7	Requirements for de-energized tap-changers	38
7.1	General requirements	38
7.1.1	Rated characteristics	38
7.1.2	Types	39
7.1.3	Handles and drives	39
7.1.4	Glands.....	39
7.1.5	Interlocks.....	39
7.1.6	Mechanical end stops	39
7.2	Type tests	40
7.2.1	General	40
7.2.2	Temperature rise of contacts	40
7.2.3	Short-circuit current test	41
7.2.4	Mechanical tests.....	41
7.2.5	Dielectric tests.....	42
7.2.6	Type test certificate	47
7.3	Routine tests	47
7.3.1	Mechanical tests.....	47
7.3.2	Pressure and vacuum tests.....	47
8	Requirements for motor-drive mechanisms for de-energized tap-changers	47
8.1	General requirements	47
8.1.1	General	47
8.1.2	Compliance of component parts.....	47
8.1.3	Permissible variation of auxiliary supply	47
8.1.4	Tap position indicator	47
8.1.5	Limiting devices.....	48
8.1.6	Operation counter.....	48
8.1.7	Manual operation of the motor-drive mechanism	48
8.1.8	Motor-drive cubicle	48
8.1.9	Protection against access to hazardous parts	48
8.2	Type tests	48
8.2.1	Mechanical load test.....	48
8.2.2	Overrun test	49
8.2.3	Degree of protection of motor-drive cubicle.....	49
8.3	Routine tests	49
8.3.1	Mechanical tests.....	49
8.3.2	Auxiliary circuits insulation test.....	49
9	Nameplate	49
9.1	Tap-changers (on-load and de-energized).....	49

9.2	Motor-drive mechanisms	50
10	De-energized tap-changer warning label.....	50
11	Manufacturers operating instructions	51
Annex A (normative) Supplementary information on switching duty on main and transition contacts relating to resistor type tap-changers.....		52
Annex B (normative) Supplementary information on switching duty relating to reactor type tap-changers		58
B.1	Additional test parameters	58
B.1.1	Service duty test.....	58
B.1.2	Breaking capacity test	58
B.2	Duty of switching contacts	58
Annex C (normative) Method for determining the equivalent temperature of the transition resistor using power pulse current		69
Annex D (informative) Simulated a.c. circuits for service duty and breaking capacity tests		70
D.1	General.....	70
D.2	Transformer method.....	70
D.3	Resistance method	71
Annex E (informative) Example of a synthetic test circuit for service duty test of vacuum type tap-changers		73
E.1	Definitions with relevance to the synthetic test circuit.....	73
E.1.1	Synthetic test circuit	73
E.1.2	Simulated a.c. test circuit.....	73
E.1.3	Pre-arc	73
E.1.4	Making voltage	73
E.2	Example for the test setup of a synthetic test circuit.....	73
E.3	Example for the breaking/making condition during a switching operation.....	74
Bibliography.....		76
Figure 1 – Short-circuit test current (r.m.s. value) as a multiple of the maximum rated through-current (on-load tap-changer)		25
Figure 2 – Time sequence for the application of test voltage (on-load tap-changer).....		34
Figure 3 – Short-circuit test current (r.m.s. value) as a multiple of the maximum rated through-current (de-energized tap-changer).....		41
Figure 4 – Time sequence for the application of test voltage (de-energized tap-changer)		46
Figure 5 – Warning label (example)		50
Figure A.1 – Examples of current and voltage vectors for resistor type tap-changers		53
Figure B.1 – Operating sequence of reactor type tap-changers with selector switch.....		59
Figure B.2 – Current and voltage vectors for reactor type tap-changers with selector switch		60
Figure B.3 – Operating sequence of reactor type tap-changers with selector switch and equalizer windings		61
Figure B.4 – Current and voltage vectors for reactor type tap-changers with selector switch and equalizer windings.....		62
Figure B.5 – Operating sequence of a reactor type tap-changer with diverter switch and tap selector		64
Figure B.6 – Current and voltage vectors for reactor type tap-changers with diverter switch and tap selector		65

Figure B.7 – Operating sequence of a reactor type tap-changer with vacuum interrupter and tap selector	67
Figure B.8 – Current and voltage vectors for reactor type tap-changers with vacuum interrupter and tap selector	68
Figure D.1 – Simulated test circuit – Transformer method	70
Figure D.2 – Simulated test circuit – Resistance method	71
Figure E.1 – Synthetic test circuit for service duty test of vacuum type tap-changers	73
Figure E.2 – Currents of the synthetic test circuit	74
Figure E.3 – Example of the synthetic test for a switching operation with equal voltages for breaking and making duty	74
Table 1 – Temperature of tap-changer environment	16
Table 2 – Contact temperature-rise limits for on-load tap-changers	19
Table 3 – Test voltage levels for on-load tap-changers	30
Table 4 – Contact temperature-rise limits for de-energized tap-changers	40
Table 5 – Test voltage levels for de-energized tap-changers	43
Table A.1 – Duty of main and transition contacts for resistor type tap-changers (non-vacuum type)	54
Table A.2 – Effect of load power-factor on circuit-breaking duty for resistor type tap-changers (non-vacuum type)	55
Table A.3 – Duty of main and transition contacts for resistor type tap-changers (vacuum type) (1 of 2)	56
Table B.1 – Duty of switching contacts for reactor type tap-changers with selector switch – Switching direction from P1 to P5	59
Table B.2 – Duty of switching contacts for reactor type tap-changers with selector switch and equalizer windings – Switching direction from P1 to P5	61
Table B.3 – Duty of switching contacts for reactor type tap-changers with diverter switch and tap selector – Switching direction from P1 to P7	63
Table B.4 – Duty of switching contacts for reactor type tap-changers with vacuum interrupter and tap selector – Switching direction from P1 to P11	66

TAP-CHANGERS –

Part 1: Performance requirements and test methods

1 Scope

This part of IEC 60214 applies to on-load tap-changers of both resistor and reactor types, de-energized tap-changers, and their motor-drive mechanisms.

It applies mainly to tap-changers immersed in mineral insulating oil according to IEC 60296 but may also be used for tap-changers with air or gas insulation or immersed in other insulating liquids insofar as conditions are applicable.

It applies mainly to tap-changers with arcing contacts but may also be used for arcing-free on-load tap-changers (such as electronic switching) insofar as conditions are applicable.

This part of IEC 60214 applies to power and distribution transformers of all types and also to reactors.

It does not apply to transformers and reactors mounted on railway rolling stock.

2 Normative references

The following documents, in whole or in part, are normatively referenced in this document and are indispensable for its application. For dated references, only the edition cited applies. For undated references, the latest edition of the referenced document (including any amendments) applies.

IEC 60050 (all parts), *International Electrotechnical Vocabulary* (available at <http://www.electropedia.org>)

IEC 60050-421, *International Electrotechnical Vocabulary – Chapter 421: Power transformers and reactors*

IEC 60060-1, *High voltage test techniques – Part 1: General definitions and test requirements*

IEC 60076-3:2013, *Power transformers – Part 3: Insulation levels, dielectric tests and external clearances in air*

IEC 60076-7:2005, *Power transformers – Part 7: Loading guide for oil-immersed power transformers*

IEC 60076-21:2011, *Power transformers – Part 21: Standard requirements, terminology, and test code for step-voltage regulators*

IEC 60137:2008, *Insulated bushings for alternating voltages above 1 000 V*

IEC 60214-2:2004, *Tap-changers – Part 2: Application guide*

IEC 60270, *High-voltage test techniques – Partial discharge measurements*

IEC 60296, *Fluids for electrotechnical applications – Unused mineral insulating oils for transformers and switchgear*

IEC 60529, *Degrees of protection provided by enclosures (IP Code)*

3 Terms and definitions

For the purposes of this document, the terms and definitions given in IEC 60050-421 as well as the following apply.

3.1

on-load tap-changer

OLTC

device for changing the tap connections of a winding, suitable for operation while the transformer is energized or on load

Note 1 to entry: On-load tap-changers are sometimes called load tap-changers (LTC).

3.2

non-vacuum type on-load tap-changer

on-load tap-changer with contacts that break and make the load and circulating currents and where the arcing takes place in a liquid or gas, the tap-changer itself being placed in liquid or gas

Note 1 to entry: This definition does not apply to arcing-free on-load tap-changers.

3.3

vacuum type on-load tap-changer

on-load tap-changer where vacuum interrupters (VI) break and make the load and circulating currents, the tap-changer itself being placed in a different medium such as liquid or gas

3.4

tap selector

device designed to carry, but not to make or break, current, used in conjunction with a diverter switch to select tap connections

3.5

diverter switch

switching device used in conjunction with a tap selector to carry, make and break currents in circuits which have already been selected

Note 1 to entry: Diverter switches are sometimes called arcing switches.

3.6

selector switch

switching device capable of carrying, making and breaking current, combining the duties of a tap selector and a diverter switch

Note 1 to entry: Selector switches are sometimes called arcing tap switches.

Note 2 to entry: In non-vacuum type selector switches the selection of tap connections (tap selector duty) and the diversion of the through-current (diverter switch duty) are carried out by the same contacts.

Note 3 to entry: In vacuum type selector switches the selection of tap connections (tap selector duty) and the diversion of the through-current (diverter switch duty) are carried out by different contacts.

3.7**de-energized tap-changer****DETC**

device for changing the tap connections of a winding, suitable for operation only while the transformer is de-energized (isolated from the system)

Note 1 to entry: De-energized tap-changers are sometimes called off-circuit tap-changers.

Note 2 to entry: De-energized tap-changers are sometimes abbreviated as DTC.

3.8**change-over selector**

device designed to carry, but not to make or break, through-current, used in conjunction with the tap selector or selector switch to enable its contacts and the connected taps to be used more than once when moving from one extreme position to the other

3.9**coarse change-over selector**

change-over selector connecting the tap winding to either the main winding or the coarse winding or parts thereof

3.10**reversing change-over selector**

change-over selector connecting either end of the tap winding to the main winding

3.11**transition impedance**

resistor or reactor consisting of one or more units bridging the tap in use and the tap next to be used, for the purpose of transferring load from one tap to the other without interruption or appreciable change in the load current, at the same time limiting the circulating current for the period that both taps are used

Note 1 to entry: For reactor type tap-changers, the transition impedance (reactor) is commonly called a preventive auto transformer. Reactor type tap-changers normally use the bridging position as a service position (mid-point or centre tapped reactor tap-changers) and, therefore, the reactor is designed for continuous operation.

3.12**preventive auto transformer**

auto transformer (or centre tapped reactor) used in on-load tap-changing and regulating transformers, or step voltage regulators to limit the circulating current when operating on a position in which two adjacent taps are bridged, or during the change of tap between adjacent positions

3.13**equalizer winding**

winding on the same magnetic circuit (core) as the excitation and tap winding of a reactor type regulating transformer with approximately half the number of turns of each tap section

3.14**drive mechanism**

means by which the drive to the tap-changer is actuated

Note 1 to entry: The mechanism may include an independent means of storing energy to control the operation.

3.15**set of contacts**

pair of individual fixed and moving contacts or a combination of such pairs operating substantially simultaneously

3.16

diverter switch and selector switch main contacts <of a resistor type tap-changer>
set of through-current carrying contacts which usually by-passes the main switching contact and only commutates any current (sparking often occurs)

3.17

diverter switch and selector switch main switching contacts <of a resistor type tap-changer>
set of contacts which has no transition resistor between the transformer winding and the contacts and makes and breaks current (arcing will occur)

Note 1 to entry: In case of vacuum type tap-changers, these contact systems are replaced by vacuum interrupters.

3.18

diverter switch and selector switch transition contacts, <of a resistor type tap-changer>
set of contacts which is connected in series with a transition resistor and makes or breaks current (arcing will occur)

Note 1 to entry: In case of vacuum type tap-changers, these contact systems are replaced by vacuum interrupters.

3.19

transfer contacts <of a reactor type tap-changer>
set of contacts that makes or breaks current

Note 1 to entry: Where by-pass contacts are not provided, the transfer contact is a continuous current-carrying contact.

3.20

by-pass contacts <of a reactor type tap-changer>
set of through-current carrying contacts that commutates the current to the transfer contacts without any arc (sparking may occur)

3.21**bridging position**

position of a reactor type tap-changer with the selector and transfer contacts being on two adjacent taps and with the output terminal being electrically in the middle between two adjacent taps

3.22**non-bridging position**

position of a reactor type tap-changer with the selector and transfer contacts being on the same tap

3.23**circulating current**

that part of the current that flows through the transition impedance at the time when two taps are momentarily bridged during a tap-change operation for a resistor type tap-changer or when bridged in an operating position for a reactor type tap-changer

Note 1 to entry: The circulating current is due to the voltage difference between the taps.

3.24**switched current**

prospective current to be broken during switching operation by each set of main switching or transition contacts (resistor type tap-changer) or transfer contacts (reactor type tap-changer) incorporated in the diverter switch or the selector switch

3.25**recovery voltage**

power-frequency voltage which appears across each set of main switching or transition contacts (resistor type tap-changer) or transfer contacts (reactor type tap-changer) of the diverter switch or selector switch after these contacts have broken the switched current

3.26**tap-change operation**

complete sequence of events from the initiation to the completion of a tap-change from one service tap position to an adjacent position

3.27**cycle of operation**

movement of the tap-changer from one end of its range to the other end and the return to its original position

3.28**rated insulation level**

withstand values of the impulse and applied voltages to earth, and where appropriate between phases, and between those parts where insulation is required

3.29**rated through-current** I_r

current flowing through an on-load tap-changer towards the external circuit, which the apparatus is capable of transferring from one tap to the other at the relevant rated step voltage and which can be carried continuously while meeting the requirements of this standard

3.30**maximum rated through-current** I_{rm}

highest rated through-current for which the tap-changer is designed for and all the current related tests are based on

3.31**rated step voltage** U_{ir}

for each value of rated through-current, the highest permissible voltage between terminals which are intended to be connected to successive taps of the transformer

3.32**relevant rated step voltage**

highest step voltage permitted in connection with a given rated through-current

3.33**maximum rated step voltage** U_{irm}

highest value of the rated step voltage for which the tap-changer is designed

3.34**rated frequency**

frequency of the alternating current for which the tap-changer is designed

3.35**number of inherent tap positions**

highest number of tap positions for half a cycle of operation for which a tap-changer can be used according to its design

Note 1 to entry: The term “tap positions” is generally given as the \pm value of the relevant number, for example, ± 11 positions. They are in principle also valid for the motor-driven mechanism. When using a “number of tap positions” in connection with a transformer, this always refers to the number of service tap positions of the transformer.

3.36

number of service tap positions

number of tap positions for half a cycle of operation for which a tap-changer is used in the transformer

Note 1 to entry: The term “tap position” is generally given as the \pm values of the relevant number, for example, ± 11 positions. They are in principle also valid for the motor-driven mechanism. When using the term “number of tap positions” in connection with a transformer, this always refers to the number of service tap positions of the transformer.

3.37

type test

test made on a tap-changer which is representative of other tap-changers, to demonstrate that these tap-changers comply with the specified requirements not covered by the routine tests: a tap-changer is considered to be representative of others if it is built to the same drawings using the same techniques and same materials

Note 1 to entry: In general a type test can be carried out on a tap-changer or the components of a tap-changer or a family of tap-changers or components.

Note 2 to entry: A family of tap-changers is a number of tap-changers based on the same design and having the same characteristics, with the exception of the insulation levels to earth and possibly between phases, the number of steps and in the case of OLTCs the value of the transition impedance.

Note 3 to entry: Design variations that are clearly irrelevant to a particular type test would not require that type test to be repeated.

Note 4 to entry: Design variations that cause a reduction in values and stresses relevant to a particular type test do not require a new type test if accepted by the purchaser and the manufacturer.

3.38

routine test

test to which each individual tap-changer is subjected

Note 1 to entry: In general a routine test can be carried out on a tap-changer or the components of a tap-changer.

3.39

motor-drive mechanism

driving mechanism which incorporates an electric motor and a control circuit

3.40

step-by-step control <of a motor-drive mechanism>

device for stopping the motor-drive mechanism after completion of a tap-change, independently of the operating sequence of the control switch

3.41

tap position indicator

device for indicating the tap position of the tap-changer

3.42

tap-change in progress indicator

device for indicating that the motor-drive mechanism is running

3.43

limit switches

devices for preventing operation of the tap-changer beyond either end position, but allowing operation in the opposite direction

3.44**mechanical end stop**

device which physically prevents operation of the tap-changer beyond either end position, but allows operation in the opposite direction

3.45**parallel control device**

control device to move, in the case of parallel operation of several transformers with taps, all tap-changers to the required position and to avoid divergence of the respective motor-drive mechanisms

Note 1 to entry: Such devices would be necessary also in the case of single-phase transformers forming a three-phase bank when each single-phase tap-changer is fitted with its own motor-drive mechanisms.

3.46**emergency tripping device**

device for stopping the motor-drive mechanism at any time in such a way that a special action has to be performed before the next tap-change operation can be started

3.47**overcurrent blocking device**

device for preventing or interrupting operation of the motor-drive mechanism for the period in which an overcurrent exceeding a pre-set value is flowing in the transformer winding

Note 1 to entry: Where diverter or selector switches are actuated by spring energy systems, interruption of the operation of the motor-drive mechanism will not prevent operation of the diverter or selector switch if the spring release has been actuated.

3.48**restarting device**

device designed to restart the motor-drive mechanism after an interruption of the supply voltage to complete a tap-change operation already initiated

3.49**operation counter**

device for indicating the number of tap-changes accomplished

3.50**manual operation of a motor-drive mechanism**

operation of the tap-changer manually by a device, blocking at the same time operation by the electric motor

3.51**motor-drive cubicle**

cubicle that houses the motor-drive mechanism

3.52**protective device against running-through**

device that stops the motor-drive mechanism in case of a failure of the step-by-step control circuit which would cause the motor-drive mechanism to run through several tap positions

3.53**class I tap-changer**

tap-changer only suitable for use at the neutral point of windings

3.54**class II tap-changer**

tap-changer suitable for use at any position in the windings

3.55**in-tank tap-changer**

tap-changer mounted inside the main transformer tank and immersed in the insulating liquid of the transformer

Note 1 to entry: See IEC 60214-2 for further details.

3.56**compartment type tap-changer**

tap-changer with its own housing mounted outside the main transformer tank and immersed in its own insulating liquid

Note 1 to entry: See IEC 60214-2 for further details.

3.57**gas immersed tap-changer**

tap-changer mounted inside the main tank of the gas filled type transformer or in a container outside the main tank and immersed in the insulating gas

Note 1 to entry: Usually the insulating gas is SF₆.

3.58**air insulated tap-changer**

tap-changer where the insulation medium is the air at atmospheric pressure

Note 1 to entry: This kind of tap-changer is usually mounted to a dry-type transformer and does not need its own container.

3.59**maintenance**

measure on the tap-changer that needs the transformer to be taken out of service

Note 1 to entry: Inspection is a measure on the tap-changer that does not need the transformer to be taken out of service.

Note 2 to entry: Replacement of parts is dependent on the findings resulting from the maintenance.

3.60**highest voltage for equipment**

U_m

highest r.m.s. phase-to-phase voltage in a three-phase system for which a tap-changer is designed with respect to its insulation

4 Service conditions**4.1 Temperature of tap-changer environment**

Unless more onerous conditions are specified by the purchaser, liquid immersed tap-changers shall be regarded as suitable for operation over the ranges of temperature given in Table 1.

Table 1 – Temperature of tap-changer environment

Tap-changer	Temperature	
	Minimum	Maximum
Compartment type tap-changer	–25 °C	40 °C
In-tank tap-changer	–25 °C	105 °C
NOTE 1 For the definitions of the tap-changer, see 3.55 and 3.56.		
NOTE 2 The value of 105 °C quoted above is based on the maximum top oil temperature in case of normal cyclic loading as specified in IEC 60076-7.		
NOTE 3 Minimum and maximum liquid temperatures of step-voltage regulators established in IEC 60076-21 take precedence.		

4.2 Temperature of motor-drive mechanism environment

Unless more onerous conditions are specified by the purchaser, motor-drive mechanisms shall be regarded as suitable for operation in any ambient temperature between –25 °C and 40 °C.

For more onerous conditions for tap-changer or motor-drive mechanism environments, reference should be made to IEC 60214-2.

4.3 Overload conditions

Tap-changers which comply with this standard and are selected and installed in accordance with IEC 60214-2 shall not restrict emergency loading of the transformer according to IEC 60076-7, which could result in top oil temperatures as high as 115 °C.

See Note 3 in Table 1 in which maximum liquid temperature limit of step-voltage regulators relates to 200 % overload for half an hour.

5 Requirements for on-load tap-changers

5.1 General requirements

5.1.1 Rating

5.1.1.1 Rated characteristics

The rated characteristics of an on-load tap-changer are:

- rated through-current;
- maximum rated through-current;
- rated step voltage;
- maximum rated step voltage;
- rated frequency;
- rated insulation level.

5.1.1.2 Interrelation between rated through-current and rated step voltage

Up to the maximum rated through-current of the on-load tap-changer there may be different assigned combinations of values of rated through-current and corresponding rated step voltage. When a value of rated step voltage is referred to a specific value of rated through-current it is called the “relevant rated step voltage”.

5.1.2 Compartments for diverter and selector switches

The liquid filled compartments for diverter and selector switches shall be liquid-tight. The gas filled compartments for diverter and selector switches shall be gas-tight. Where appropriate, pressure and vacuum withstand values shall be declared by the manufacturer.

If the insulating liquid is to be supervised by dissolved and free gases analysis (DGA), the liquid filled compartment of the diverter or selector switch should be provided with a liquid conservator which has a liquid and gas-tight barrier. In case of vacuum type OLTCs this matter should be discussed between transformer manufacturer and customer

5.1.3 Liquid-level gauges and gas monitoring devices

Liquid compartments for diverter or selector switches with integral expansion volume or separate conservators for these compartments, when fitted, shall be provided with liquid-level gauges.

Gas compartments for diverter or selector switches shall be provided with gas monitoring devices.

5.1.4 Safety requirements for protection against internal failure

5.1.4.1 General

In order to reduce the consequences resulting from an internal failure within the diverter or selector switch compartment, a protective device shall be fitted. The protective device shall have a function to detect a failure arc or a failure mode that finally will lead to a failure arc.

It is up to the manufacturer to recommend a protection device for the selected OLTC. At least one protective device shall be fitted.

The most common types of protection devices for liquid immersed OLTC are described below.

The tap selector compartments of compartment type on-load tap-changers are usually piped to the main transformer buchholz relay. Consideration should also be given to fitting a separate buchholz relay between the tap selector compartment and the conservator.

NOTE For those types of on-load tap-changers that do not create an arc and are installed in sealed compartments, other protective devices can be used.

5.1.4.2 Liquid-flow controlled relay

The liquid-flow controlled relay, installed in the pipe between the top of the diverter or selector switch and the liquid conservator, shall respond at a predetermined liquid flow and enable the transformer to be tripped.

5.1.4.3 Overpressure relay

The overpressure relay shall respond in the event of the pressure in the diverter or selector switch compartment exceeding a predetermined value, and enable the transformer to be tripped.

5.1.4.4 Pressure relief device

The pressure relief device shall open when a predetermined pressure is exceeded and its opening shall protect the diverter or selector switch compartment.

Where a pressure relief device is the sole protection, it shall also be arranged with contacts to enable the transformer to be tripped.

If a pressure relief device is fitted, the use of a self-sealing diaphragm type is possible. Consideration should also be given to fitting an outlet such as ducting or trunking from the pressure relief device to protect personnel from the displaced liquid. The use of such devices should be subject to agreement between the manufacturer and the purchaser.

5.1.5 Limiting devices for the protection against transient overvoltages

For on-load tap-changers which incorporate limiting devices for transient overvoltages, the manufacturer of the on-load tap-changer shall give full details of the protective characteristics, together with any limitations which might be imposed during tests on the completed transformer.

When spark gaps are used, care shall be taken to ensure that, after spark-over, the discharge is quenched automatically.

5.1.6 Change-over selector recovery voltages

When coarse or reversing change-over selectors operate they momentarily disconnect the tap winding. This can cause high recovery voltages across the change-over selector contacts during contact separation due to capacitive coupling between the tap winding and adjacent winding(s). The on-load tap-changer manufacturer shall declare any limiting switching parameters for change-over selectors incorporated in an on-load tap-changer.

NOTE IEC 60214-2 gives further details of selection, control circuits and devices and transformer testing recommendations.

5.1.7 Leakage inductance in coarse fine regulation arrangements

When changing from the end of the tap winding to the end of the coarse winding or vice versa with resistor type tap-changers, a high leakage inductance can be set up with the two windings in series opposition. This can cause a phase shift between the switched current and recovery voltage of the diverter or selector switch. This may result in extended arcing of the switch.

The on-load tap-changer manufacturer shall declare any switching limitations.

NOTE IEC 60214-2 gives further details of selection and winding configurations regarding leakage inductance.

5.2 Type tests

5.2.1 General

The following type tests shall be performed on samples of the relevant on-load tap-changers after their final development or on equivalent components provided that the manufacturer can demonstrate that the relevant test conditions and results are not influenced by testing only components instead of the complete tap-changer:

NOTE No differentiation has to be made with respect to the test supplies with frequencies of 50 Hz or 60 Hz. The tests can be carried out with either frequency.

- temperature rise of contacts (5.2.2);
- switching tests (5.2.3);
- short-circuit current test (5.2.4);
- transition impedance test (5.2.5);
- mechanical tests (5.2.6);
- tightness test (5.2.7)
- dielectric tests (5.2.8).

5.2.2 Temperature rise of contacts

Tests shall be performed to verify that the temperature rise above the medium surrounding each type of contact which carries through-current continuously in service does not exceed the values given in Table 2 when the contacts have reached a steady temperature when carrying 1,2 times the maximum rated through-current. Contacts that should be tested are those which carry current continuously in service and are opened and closed or being moved at some instant during service life or maintenance, except bolted connections.

NOTE 1 If a current carrying contact carries at least 90 % of the through-current, it is not necessary to measure the temperature rise of the contacts being by-passed.

NOTE 2 Contacts operating in vacuum do not need to be measured.

For reactor type tap-changers without an equalizer winding the highest temperature rise is experienced in the bridging position which has the highest tap voltage impressed upon it.

For reactor type tap-changers with an equalizer winding the highest temperature rise will be experienced in either the bridging or non-bridging positions. The preventive autotransformer (reactor) is energized in all tap positions (non-bridging and bridging). Highest temperature rise will be experienced in the bridging or non-bridging position that has the highest total tap voltage impressed upon the reactor.

The current in these positions is determined by the through-current, as well as by the circulating current and the power factor of the through-current. The type test shall be performed in the position in which the highest total current flows through the tap-changer. The currents are calculated on the following basis:

- through-current equal to 1,2 times the maximum rated through-current;
- circulating current equal to 50 % of the maximum rated through-current (or otherwise specified by the manufacturer and stated in the type test report);
- power factor equal to 80 %.

Refer to Annex A and Annex B for the most onerous conditions for resistor and reactor type tap-changers, respectively, for the majority of contact arrangements.

Meeting these conditions proves the overload capacity as referred to in 4.3.

Table 2 – Contact temperature-rise limits for on-load tap-changers

Contact material	In air K	In SF ₆ K	In liquid K
Plain copper	35	40	20
Silver-faced copper/alloys	65	40	20
Other materials	By agreement	By agreement	20
In SF ₆ the maximum allowable contact temperature under overload conditions is 150 °C. When the temperature of SF ₆ is controlled by a specific method, the manufacturer shall specify an allowable contact temperature rise, which takes into consideration reduced SF ₆ temperature surrounding the OLTC. Subsequent tests by the manufacturer using that method shall verify that the maximum allowable contact temperature of 150 °C will not be exceeded.			

When the surrounding medium is liquid, the test shall be performed at a starting liquid temperature of not more than 40 °C and not less than 10 °C.

The temperature of the surrounding medium shall be measured at not less than 25 mm below the contacts.

The temperature shall be measured by thermocouples or other suitable means positioned in a manner to accurately reflect the actual contact temperature as near the point of contact as possible. The measuring device should be embedded into the contact or brazed or welded onto the contact so that it is measuring the bulk temperature of the contact and not the temperature of the interface between contact and cooling medium.

The temperature condition is considered to be steady when the difference of the temperature between the contact and the surrounding medium does not change more than 1 K over an hour.

The cross-section and insulation of the conductor carrying the current into the on-load tap-changer or components under test shall be stated.

5.2.3 Switching tests

5.2.3.1 General

Switching tests which include service duty tests and breaking capacity tests, shall simulate the most onerous conditions for which the on-load tap-changer is rated. Refer to Annex A and Annex B for the most onerous conditions for resistor and reactor type tap-changers, as well as for vacuum-type and non-vacuum type tap-changers, respectively, for the majority of contact arrangements.

For vacuum type on-load tap-changers the breaking capacity test shall be performed after the completion of the service duty test using the identical test sample.

The switching tests may be limited to the diverter or selector switch after proving that the contact operating conditions are not affected by such limitations.

If the diverter or selector switch has several sets of contacts which operate in a definite sequence, it is not permitted to test each set of contacts separately from the others unless it can be proved that the operating conditions of any one set of contacts are not affected by the operation of the other sets of contacts.

Where resistors are used as transition impedances, these may be placed outside the apparatus if necessitated by the construction of the on-load tap-changer or the test circuit, and they may have a higher thermal capacity than those which are employed in service, unless otherwise specified.

The value and type of transition impedance shall be stated.

Contacts and transformer liquid in the case of liquid-immersed tap-changers, shall not be renewed during the tests.

In the case of three-phase switches, it is normally sufficient to test the contacts of one phase.

If a particular on-load tap-changer has more than one combination of rated through-current and rated step voltage, at least two breaking capacity tests shall be performed, one at maximum rated through-current I_{rm} and its relevant step voltage U_{ir} and one at the maximum rated step voltage U_{irm} and its rated through-current I_r .

The switching curve can be drawn using the results of the two tests above and a value of voltage at mid-current calculated from the following formula:

$$\frac{I_{rm} + I_r}{2} (U_x) = \sqrt{U_{ir} I_{rm} \times U_{irm} I_r}$$

The arrangement for testing shall be such that, except where otherwise specified, the switched current, the recovery voltage, or the product of these shall not, in any case, be less than 95 % of the calculated values appropriate to the switching cycle, see Tables A.1 and A.3 and Tables B.1, B.2, B.3 and B.4 at the appropriate through-current and relevant rated step voltage.

5.2.3.2 Service duty test

5.2.3.2.1 General

This test shall be performed in accordance with one of the tests in 5.2.3.2.2 to 5.2.3.2.6, the appropriate method to be decided by the manufacturer. After the tests, inspections of contact wear shall take place, the results of these leaving no doubt as to the suitability of the on-load tap-changer for service. The number of tap-change operations N to be carried out depends on the type of on-load tap-changer. For non-vacuum type on-load tap-changers N shall be 50 000 tap-change operations. In case of vacuum type on-load tap-changers N shall be equal to 1,2 times the number of tap-change operations between maintenance according to the manufacturer's handbook but N shall not be less than 50 000 operations. This number of operations shall be declared by the tap-changer manufacturer.

NOTE The results of this test can be used by the manufacturer to demonstrate that the contacts used for making and breaking current are capable of performing, without replacement of the contacts, the number of tap-change operations declared by the manufacturer at the maximum rated through-current and at the relevant rated step voltage.

For non-vacuum type on-load tap-changers, this test can be combined with the tightness test, see 5.2.7.2.

5.2.3.2.2 Service duty test at rated step voltage

The contacts of the diverter and selector switches shall be subjected to a number of operations corresponding to N tap-change operations in normal service when carrying a current corresponding to not less than the maximum rated through-current and the relevant rated step voltage.

Comparison of oscillograms taken at regular intervals during the test shall show that there is no significant alteration in the characteristics of the on-load tap-changer in such a way as to endanger the operation of the apparatus. Twenty oscillograms shall be taken at the start of the test, and 20 after each succeeding quarter of the number of N ($N/4$) operations, making a total of 100 oscillograms.

NOTE Generally, it is sufficient to compare the series of oscillograms taken at the beginning and at the end of the test.

5.2.3.2.3 Service duty test at reduced step voltage (non-vacuum type on-load tap-changers)

A test at reduced step voltage may be performed under the following conditions:

- a) 100 operations at the maximum rated through-current and the relevant rated step voltage shall be performed with new contacts in clean transformer liquid. Each operation shall be oscillographically recorded;
- b) when the oscillograms taken at a) indicate that no arcing time exceeds $1,2/2f$ s, where f is the rated frequency in hertz, then the number of operations of the service duty test as in d) shall be N ;
- c) when the oscillograms taken at a) indicate that arcing times in excess of $1,2/2f$ s are occurring, then the number of operations of the service duty test as in d) shall be increased by $(2S/100) \times N$ where S is the total number of half cycles of arcing current, in the 100 operations from item a) above, which exceed $1,2/2f$ s;
- d) a service duty test of N operations, increased by the number of operations resulting from item c) if applicable, shall be performed with a current not less than the maximum rated

through-current and at reduced step voltage. This voltage shall be such that the switched current is not less than that occurring during operations at the relevant rated step voltage. Furthermore, current chopping shall not significantly affect the contact erosion. In order to obtain the specified test conditions, the value of the transition impedance shall be suitably modified;

- e) without change of contacts or liquid, 100 operations shall be performed at the maximum rated through-current and the relevant rated step voltage, each operation being oscillographically recorded. Comparison of these oscillograms with those taken in the series of operations under item a) shall show no alteration in the characteristics of the on-load tap-changer which might endanger the operation of the apparatus.

The test sequence specified above is designed to give substantially the same contact erosion as would occur during N operations at maximum rated through-current and the relevant rated step voltage.

5.2.3.2.4 Service duty test at reduced step voltage (vacuum type on-load tap-changers)

A test at reduced step voltage may be performed under the following conditions:

- a) 1 000 operations at the maximum rated through-current and the relevant rated step voltage shall be performed with new contacts in clean transformer liquid. Each operation shall be oscillographically recorded. Arcing times exceeding $1,2/2f$ s shall not occur;
- b) a service duty test of N operations shall be performed with a current not less than the maximum rated through-current and at reduced step voltage. This voltage shall be such that the switched current and the arcing times are not less than those occurring during operations. In order to obtain the specified test conditions, the value of the transition impedance shall be suitably modified;
- c) without change of contacts or liquid, 1 000 operations shall be performed at the maximum rated through-current and the relevant rated step voltage, each operation being oscillographically recorded. Arcing times exceeding $1,2/2f$ s shall not occur. Comparison of these oscillograms with those taken in the series of operations under item a) shall show no alteration in the characteristics of the on-load tap-changer which might endanger the operation of the apparatus.

The test sequence specified above is designed to give substantially the same contact erosion as would occur during N operations at maximum rated through-current and the relevant rated step voltage.

5.2.3.2.5 Service duty test in a synthetic test circuit (vacuum type on-load tap-changers)

5.2.3.2.5.1 General

The service duty test is allowed to be performed in a synthetic test circuit as long as the following requirements are fulfilled:

- the charges dissipated in the arcs shall be at least the same as those gained in an a.c. test circuit;
- the current through the breaking arcs shall be tuned to be substantially sinusoidal and the charge shall be at least that of the corresponding sine half wave and the peak value should be at least 95% of that of the corresponding sine half wave;
- the polarity of the breaking current in the arcs shall be changed regularly and ending up with almost the same amount of operations with each polarity;
- the arcing times when breaking shall be varied in substantially the same way as in an a.c. test circuit;
- a statistically correct number of operations shall start at a current range equal to the corresponding a.c. r.m.s.-value times $\sqrt{2}$;

- dissipated charges, oscillograms showing the current shapes and arcing time distributions shall be presented in the final report;
- the test can be performed with a recovery voltage or not, see the paragraphs below;
- for contacts closing with a voltage across the contacts before closing, a making voltage shall be applied across the contacts in due time before closing the contacts to gain the correct closing conditions;
- when the pre-arc starts, the current obtained shall correspond to that in real service both regarding value and derivative;
- the polarity of the making voltage shall be changed regularly and ending up with almost the same amount of operations with each polarity;
- the making voltage has to be varied in substantially the same way as in an a.c. test circuit;
- oscillograms and data showing the making conditions shall be presented in the final report;
- in case of having more than one set of contacts operating in a sequence, these contacts are allowed to be tested in this circuit separately after each other. However, all set of contacts have to be operated to achieve the correct mechanical properties (such as velocity, bouncing, etc.).

5.2.3.2.5.2 Synthetic test circuit without recovery voltage

After the $1,2 \times N$ operations have been carried out, and before the breaking capacity test, 1 000 operations at full step voltage in an a.c. test circuit shall be performed as in 5.2.3.2.4. No arcing times exceeding $1,2/2f$ s are allowed.

5.2.3.2.5.3 Synthetic test circuit with recovery voltage

The recovery voltage applied after the arc is extinguished is allowed to be a d.c. voltage or an a.c. voltage.

In case of an a.c. recovery voltage, this shall be substantially sinusoidal and having at least the same derivative during voltage rise as the corresponding sine half wave and reach at least 95 % of the peak value of the corresponding sine half wave.

In case of a d.c. recovery voltage, the voltage shall be applied not later than 0,1 ms after the arc is extinguished. The level of the applied d.c. voltage shall be the same as the peak value of the true a.c. recovery voltage.

The recovery voltage should be of opposite polarity to that of the previous arc.

In case of re-ignitions of the arc exceeding $1,2/2f$ s, the following applies:

- the charge dissipated in the arc following the re-ignition, shall be at least that in an a.c. test circuit or
- the number of such re-ignitions shall be counted and a number of additional operations equal to twice as many as having arcing times exceeding $1,2/2f$ s shall be carried out.

For example, see Annex E.

5.2.3.2.6 Service duty test for selector switches

The tests may be performed as specified in either 5.2.3.2.2 to 5.2.3.2.5, whichever is applicable.

In order to approximate to service conditions, non-vacuum type selector switches shall have the test performed at not more than eight tap-change operations, these being centrally disposed about the change-over selector if such is incorporated in the tap-changer design (mid-position plus/minus 4 positions, without dead positions).

In case of vacuum type selector switches, the breaking action will take place within the vacuum interrupters and does not depend on the tap-changer position. Therefore, the above-mentioned approximation to the service conditions is not required.

When non-vacuum type selector switches are designed for operating cycle number 2 switching and no restrictions are made regarding operation sequence or load direction, the most onerous sequence according to Annex A should be applied.

When non-vacuum type selector switches are designed for operating cycle number 2 switching, and restrictions for use are such that the operation sequence and load direction will result in operation in the least onerous direction only according to Annex A, the test shall be performed with $N/2$ operations at full load parameters and $N/2$ at no-load parameters.

5.2.3.3 Breaking capacity test

Forty operations under the most onerous conditions (see Annex A and Annex B) shall be performed at a current corresponding to twice the maximum rated through-current and at its relevant rated step voltage.

In order to approximate to service conditions, non-vacuum selector switches shall have the test performed at not more than eight tap-change operations, these being centrally disposed about the change-over selector if such is incorporated in the on-load tap-changer design (mid-position plus/minus 4 positions, without dead positions).

In case of vacuum type selector switches, the breaking action will take place within the vacuum interrupters and depends not on the tap-changer position. Therefore, the above mentioned approximation to the service conditions is not required.

The oscillograms taken for each operation shall indicate that in no case is the arcing time such as to endanger the operation of the apparatus.

For resistor type tap-changers, the breaking capacity test shall be performed, if possible, with a transition resistor of the same thermal and ohmic design as that to be employed in service. If this is not possible, the impedance as used in service shall be tested separately in accordance with 5.2.5.1, but with twice the maximum rated through-current for one operation only.

For vacuum type on-load tap-changers the breaking capacity test shall be performed after the completion of the service duty test using the identical test sample.

5.2.3.4 Requirements for special types of vacuum type on-load tap-changers

To cover the decrease of dielectric strength (only in cases where the VI is the only insulating distance between selected and preselected tap) the tests have to be carried out in the following order:

- a) service duty test;
- b) breaking capacity test;
- c) dielectric test between diverter switch contacts in their final open position with the full wave lightning impulse only at 80% of the rated values (see 5.2.8.2, e)).

5.2.3.5 Simulated a.c. test circuits

The tests in 5.2.3.2.2, 5.2.3.2.3, 5.2.3.2.4 and 5.2.3.3 may be performed with simulated test circuits provided it is proved that the test conditions are substantially equivalent. Two simulated test circuits that are relevant for resistor type tap-changers only are described in Annex D.

5.2.4 Short-circuit current test

All contacts of different design carrying current continuously shall be subject to short-circuit currents, each of 2 s ($\pm 10\%$) duration. In the case of liquid immersed on-load tap-changers, the test shall be performed in transformer liquid.

In the case of three-phase on-load tap-changers, it is sufficient to test the contacts of one phase only unless otherwise specified.

Three applications shall be made with an initial peak current of 2,5 ($\pm 5\%$) times the r.m.s. value of the rated short-circuit test current. The contacts shall not be moved between these applications.

When there are no facilities for point-on-wave switching and it is not possible to obtain three short-circuit applications with initial peak current 2,5 times the r.m.s. value, the following test may be used.

The r.m.s. value of the short-circuit test current may be increased so that the rated peak current is obtained for the three applications and the test duration reduced. When using this method, the product of the square of the increased r.m.s. current and the shorter test duration shall be not less than the product of the square of the rated short-circuit r.m.s. current and the two second duration.

The values of the short-circuit test current to be applied shall be as given in Figure 1.

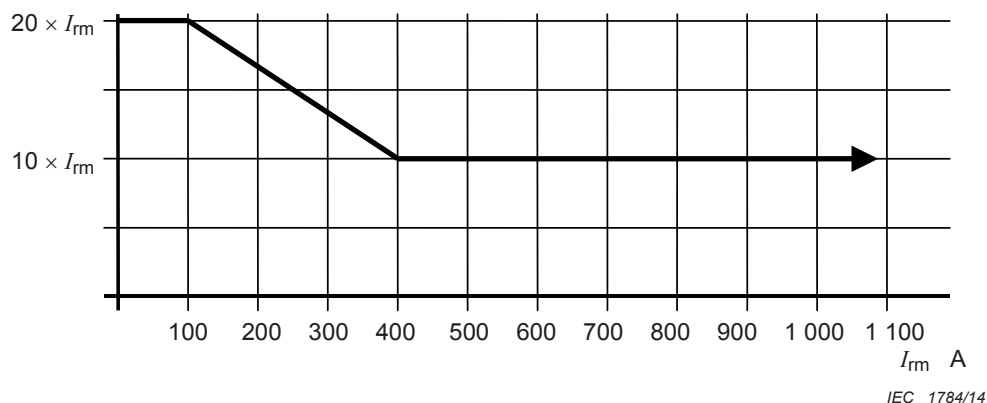

Figure 1 – Short-circuit test current (r.m.s. value) as a multiple of the maximum rated through-current (on-load tap-changer)

The open-circuit voltage for the test shall be at least 50 V.

At the conclusion of the test, the contacts shall not have been damaged so as to prevent continuing correct operation at maximum rated through-current. This has to be proven for a diverter switch or selector switch by a no load operation, oscillographically recorded, breaking any created weld. Comparison of this oscillogram with those obtained before the test shall show suitability for service. For a motor-driven sliding contact such as tap selector or change-over selector contacts, the initial operating torque shall be measured before and after the test and show suitability for service.

Other current-carrying parts shall not show signs of permanent mechanical distortion, which can influence the normal operation of the tap-changer.

For reactor type tap-changers, the short-circuit current is divided into two equal parts at the tap selector or selector switch contacts and the transfer or bypass contacts. Therefore, the current carried by each contact will be only 50 % of the full test current.

Short-circuit test parameters of step-voltage regulators in IEC 60076-21 take precedence.

5.2.5 Transition impedance test

5.2.5.1 Transition resistors

To meet the overload requirements of 4.3, the test shall be performed with 1,5 times the maximum rated through-current at the relevant rated step voltage.

The resistor shall be mounted in the on-load tap-changer as in service.

The resistor shall be loaded by operating the on-load tap-changer. The number of operations shall be equivalent to one-half of a cycle of operation. The operations shall be uninterrupted with the driving mechanism operating at its normal speed.

The temperature of the resistor at the final operation shall be recorded and determined.

The temperature rise above the surrounding liquid at 1,5 times maximum rated through-current shall not exceed 400 K for externally mounted on-load tap-changers (compartment type on-load tap-changers) or 350 K for internally mounted on-load tap-changers (in-tank on-load tap-changers).

In the case of gas immersed on-load tap-changers, the allowable temperature-rise limits depend on the nature of the gas insulation used and the materials which are in contact with or the surrounding area of the transition resistors. Gas immersed on-load tap-changers which are not encapsulated in a gas tight housing shall not be used in hazardous environments.

However, the temperature of resistors and of parts adjacent to them shall be limited to a value so that the characteristics of the assembly are not affected.

If it is not practicable to determine the temperature of the transition resistor according to the above, the method given in Annex C may then be employed.

The transition resistors shall also be tested with a current equal to at least the maximum value that would flow during the breaking capacity test at twice the maximum rated through-current and relevant rated step voltage. This test can be included in the breaking capacity test (5.2.3.3) or done as a separate test. This test is successful if the value of the resistors, measured before and after the test, should be within $\pm 10\%$ and the overall condition of the resistors shall be such that continuous service is permissible.

In cases where the rated through-current or the relevant rated step voltage is different from the maximum rated through-current and the relevant rated step voltage, it is permissible to calculate the thermal rating of the resistor from the results of the type test.

5.2.5.2 Transition reactors

Transition reactors are normally tested in accordance with the specification for the transformer with which the on-load tap-changer is intended for use.

Precautions should be taken in the design of the transition reactors to avoid high inrush currents during switching.

5.2.6 Mechanical tests

5.2.6.1 Simulation of the transformer drying procedure

To simulate a transformer drying process, the on-load tap-changer shall run through a drying procedure during type test prior to the mechanical tests listed in 5.2.6.2 to 5.2.6.5. The drying procedure and type of drying shall be declared by the manufacturer of the OLTC.

For example maximum temperatures, maximum temperature rate of rise, time sequence and vacuum level shall take into account conventional drying methods. Limitations to any of the variables shall be declared by the manufacturer of the OLTC to avoid stresses, which exceed the design characteristics of the OLTC and can result in abnormal deformation.

5.2.6.2 Mechanical endurance test

If the on-load tap-changer is of liquid-immersed design, it shall be assembled and filled with clean liquid or immersed in a test tank filled with clean liquid, and operated as for normal service conditions. The contacts shall not be energized and the full range of taps shall be utilized until a minimum of 500 000 tap-change operations have been performed. At least 50 000 tap-change operations shall be carried out on the change-over selector.

If the number of operations carried out during the service duty test is higher than or equal to the requested 500 000 operations during mechanical endurance test, it is allowed to use these operations for the verification of the 500 000 operations, provided that all test conditions fit.

For compartment type on-load tap-changers, this test may be performed at ambient temperature. For in-tank on-load tap-changers, half the number of operations shall be performed at a temperature of not less than 75 °C and half at a lower temperature, for example during the heating or cooling period, with daily temperature cycles being permitted.

Ten timing oscillograms for the diverter switch and tap selector or the selector switch, and if applicable for the change-over selector, shall be taken at the start and at the end of the mechanical endurance test. Comparison of these timing oscillograms shall show no significant difference.

For liquid immersed in-tank tap-changers, 100 operations shall be performed with the diverter switch at 115 °C and with the tap selector at 105 °C or with the selector switch at 115 °C to demonstrate the capability to withstand the mineral insulating oil temperatures during emergency loading as stated in 4.3. There are selector switch designs where the change-over selector is mounted beneath the selector switch compartment. In those cases it is allowed to test the change-over selector at 105 °C. The operation of the diverter switch or selector switch shall be oscillographically recorded. Comparison of these oscillograms with those obtained at the start and the end of the mechanical endurance test shall show suitability for service.

For both in-tank and compartment type on-load tap-changers, 100 operations shall be performed at –25 °C, with the diverter switch only or with a selector switch, and the operation of the diverter switch or selector switch oscillographically recorded. Comparison of these oscillograms with those obtained in accordance with the previous paragraph shall show suitability for service. The viscosity at –25 °C of the liquid used in this test shall be stated.

Because of the higher viscosity of currently available alternative liquids (such as ester fluids (natural or synthetic) or silicon fluids), the test at –25 °C is not applicable for those liquids. The tap-changer manufacturer has to be consulted on the minimum allowable temperature.

During the test, there shall be no failure or undue wear of the contacts or mechanical parts that would lead to mechanical failure if operation continued.

Normal maintenance according to the manufacturer's handbook is permitted during the test.

It is permitted to perform this mechanical endurance test separately on diverter switches, selector switches, tap selectors, or other components of the on-load tap-changer, provided that in each case the operation duplicates mechanically its normal service condition.

NOTE The surrounding mediums declared suitable for operation can typically be mineral insulating oil, alternative liquids (such as ester fluids (natural or synthetic) or silicon fluids), air and other gases.

5.2.6.3 Sequence test

With the on-load tap-changer assembled as in service and, if of liquid-immersed design, in clean transformer liquid, it shall be operated over one complete cycle of operations. With the contacts energized at the voltage of the recording equipment, the exact time sequence of operation of the tap selector, change-over selector, diverter switch or selector switch, as appropriate, shall be recorded.

5.2.6.4 Operation under maximum allowable static pressure

5.2.6.4.1 General

For both compartment and in-tank type on-load tap-changers of vacuum type only, 100 operations shall be performed at ambient temperature at the highest and lowest allowed pressure stated by the manufacturer. These tests can be performed on the diverter switch only or selector switch and the operation of the diverter switch or selector switch oscillographically recorded. Comparison of these oscillograms with those obtained in normal atmospheric pressure at ambient temperature shall show suitability for service.

5.2.6.4.2 Liquid immersed tap-changers

This test has to be carried out at a temperature of the surrounding liquid of not more than 40 °C. If there are no significant differences between the switching times gained without additional static pressure and maximum static pressure, the test is valid for the whole temperature range.

The manufacturer shall declare his values.

5.2.6.4.3 Gas immersed tap-changers

This test has to be carried out at a temperature of the surrounding gas of 80 °C. If there are no significant differences between the switching times gained without additional static pressure and maximum static pressure, the test is valid for the whole temperature range.

The manufacturer shall declare his values.

5.2.6.5 Pressure and vacuum tests

Appropriate tests shall be performed on the compartment and bushings of the on-load tap-changer to prove pressure and vacuum withstand values and the continued correct operation of the tap-changer. The manufacturer shall declare his pressure and vacuum values.

The external pressure test in addition to the internal pressure test shall be performed on the gas immersed tap-changer. This external pressure shall be at least 125 kPa higher than the pressure estimated at maximum temperature in the transformer main tank or container.

5.2.7 Tightness test

5.2.7.1 General

Appropriate tests shall be performed on compartments and bushings of the on-load tap-changer to prove the tightness. The manufacturer shall declare his values.

5.2.7.2 Tightness test during the service duty test

The tightness of the diverter or selector switch compartment shall be verified by a test. This test can be made at the same time as the service duty test or as a separate test as stated in 5.2.7.3.

The liquid immersed switching compartment tightness shall be verified by means of dissolved and free gases analysis (DGA).

The diverter switch or selector switch compartment shall be attached to a closed container in the same way as it is to the transformer. The volume of the container shall not exceed 10 times that of the switch compartment.

The mineral insulating oil in the diverter switch or selector switch compartment shall have a pressure of at least 20 kPa above the container pressure.

From the container, mineral insulating oil samples shall be taken at the beginning and at the end of the test. The results of the gas-in-oil analysis shall not show an increase greater than 10 ppm (by volume) of the gases usually developed during operations of on-load tap-changers, namely hydrogen (H_2), methane (CH_4), ethylene (C_2H_4), acetylene (C_2H_2) and ethane (C_2H_6).

The mineral insulating oil in the closed container should be degassed before the start of the test.

Diverter switches and selector switches employing vacuum interrupters or other devices preventing arcing to occur in the insulating liquid are not required to carry out the above tightness test providing the manufacturer can demonstrate that no other arcing takes place within the diverter/selector switch compartment.

5.2.7.3 Separate tightness test

The diverter or selector switch compartment may be tested separately as an alternative to the test described in 5.2.7.2.

The liquid immersed switching compartment tightness shall be verified by means of dissolved and free gases analysis (DGA).

The diverter switch or selector switch compartment shall be attached to a closed container in the same way as it is to the transformer. The volume of the container shall not exceed 10 times that of the switch compartment.

The mineral insulating oil in the diverter switch or selector switch compartment shall:

- have a pressure of at least 20 kPa above the container pressure;
- be doped by acetylene (C_2H_2) to a level of at least 100 000 ppm (by volume).

With the diverter switch or selector switch fully assembled, but without the contacts energized, the on-load tap-changer shall be manoeuvred for 50 000 operations. The test time shall be at least 2 weeks.

From the container, mineral insulating oil samples shall be taken at the beginning and at the end of the test. The results of the dissolved and free gases analysis (DGA) shall not show an increase greater than 10 ppm of acetylene (C_2H_2).

The mineral insulating oil in the closed container should be degassed before the start of the test.

Diverter switches and selector switches employing vacuum interrupters or other devices preventing arcing to occur in the insulating liquid are not required to carry out the above tightness test providing the manufacturer can demonstrate that no other arcing takes place within the diverter/selector switch compartment.

5.2.7.4 Tightness test for gas immersed on-load tap-changers

The switching operation of vacuum interrupters can be compromised by increase of pressure external to the interrupters. Therefore, the tightness test shall show that no gas penetration occurs from the main transformer tank into the diverter switch compartment. This shall be verified with an external pressure test at the beginning and end of the type test. The external pressure test shall be done under at least 125 kPa higher external pressure than that pressure estimated at 20 °C temperature in the transformer main tank or container. In addition, it shall be verified that the amount of penetrated gas has no influence on the long term switching operation.

5.2.8 Dielectric tests

5.2.8.1 General

The dielectric requirements of an on-load tap-changer depend on the transformer winding to which it is to be connected.

The transformer manufacturer shall be responsible not only for selecting an on-load tap-changer of the appropriate insulation level, but also for the insulation level of the connecting leads between the on-load tap-changer and the windings of the transformer.

On-load tap-changers for liquid-immersed designs shall be filled with clean transformer liquid or immersed in a test tank filled with clean transformer liquid before the tests detailed in 5.2.8.2 are performed.

Table 3 – Test voltage levels for on-load tap-changers

Highest voltage for equipment U_m kV	Full wave lightning impulse kV	Chopped wave lightning impulse kV	Switching impulse kV	Applied voltage kV
< 1,1	-	-	-	3
3,6	40	44	-	10
7,2	75 [*]	83 [*]	-	20
12	110 [*]	121 [*]	-	34 [*]
17,5	125 [*]	138 [*]	-	38
24	150 [*]	165 [*]	-	50
36	200 [*]	220 [*]	-	70
52	250	275	-	95
72,5	350 [*]	385 [*]	-	140
100	450	495	375 [*]	185

Highest voltage for equipment U_m kV	Full wave lightning impulse kV	Chopped wave lightning impulse kV	Switching impulse kV	Applied voltage kV
123	550	605	460*	230
145	650	715	540*	275
170	750	825	620*	325
245	1 050	1 155	850*	460
300	1 050	1 155	850	460
362	1 175	1 290	950	510
420	1 425	1 570	1 175*	630
550	1 675*	1 845*	1 390*	680
800	2 100	2 310	1 675*	-
1 100	2 250	2 475	1 800	-
1 200	2 250	2 475	1 800	-

NOTE Values marked with an asterisk (*) are not given in IEC 60076-1:2011 for the particular value of U_m but are included either because they represent common practice in some parts of the world or for some switching impulse levels, because they represent a co-ordinated value for a particular value of lightning impulse level (see IEC 60076-3:2013).

5.2.8.2 Nature of tests

The insulation level of the on-load tap-changer shall be proved by dielectric tests performed at the following distances:

- to earth;
- between phases (where applicable);
- between the first and last contacts of the tap selector or selector switch and, where fitted, of the change-over selector;

NOTE In case of designs, where the fixed contacts are arranged in a straight line, this test is not applicable.

- between any two adjacent contacts of the tap selector or selector switch or any other contacts relevant to the on-load tap-changer contact configuration;
- between diverter switch contacts in their final open position.

In case of vacuum type tap-changers, where any of the vacuum interrupters are open in their final open position and represent the only insulating distance between selected and pre-selected tap, item e) of the above listed dielectric tests has to be repeated after the service duty test with full wave lightning impulse only at 80 % of the rated values (see 5.2.3.4).

5.2.8.3 Test voltages

– Class I

For test a), the test voltages shall comply with appropriate values from Table 3. For tests b), c), d) and e), appropriate withstand values of full and chopped wave lightning impulse voltage, applied voltage and if applicable of switching impulse shall be declared by the manufacturer of the on-load tap-changer.

– Class II

For tests a) and b), test voltage shall comply with the appropriate values from Table 3. For tests c), d) and e), appropriate withstand values of full and chopped wave lightning impulse, applied voltage and, if applicable of switching impulse, shall be declared by the manufacturer of the on-load tap-changer.

The values in Table 3 are the highest selected test voltages for U_m and are based on Clause 7 of IEC 60076-3:2013. Table 3 should be used for selecting the test levels for 5.2.8.5 through 5.2.8.9.

5.2.8.4 Application of test voltages

For the dielectric tests, the on-load tap-changer shall be assembled, arranged and dried-out in a manner similar to that in service. It is not, however, necessary to include leads for connecting the on-load tap-changer to the windings of a transformer. If using leads they should be an approximation of that in service. Tests may be performed on separate components provided it can be shown that the same dielectric conditions apply.

For test a) of 5.2.8.2 when applied to class I and class II on-load tap-changers and test b) of 5.2.8.2 when applied to class II on-load tap-changer, the live parts of each phase shall be short-circuited and connected either to the voltage source or to the earth as appropriate.

Where the on-load tap-changer incorporates external air insulation to earth, this external insulation shall be proved in accordance with the relevant tests described in IEC 60137.

The preferred testing sequence is as follows:

- full wave lightning impulse test;
- chopped wave lightning impulse test;
- switching impulse test, when required;
- applied voltage test;
- measurement of partial discharges, when required.

5.2.8.5 Full wave lightning impulse test (LI)

The test impulse shall be a full standard lightning impulse ($1,2 \mu\text{s} \pm 30\%$ / $50 \mu\text{s} \pm 20\%$) with a maximum overshoot of 5%. The tolerance on the test voltage value is $\pm 3\%$. Each test shall comprise three voltage applications of positive polarity and three voltage applications of negative polarity, at the required value.

5.2.8.6 Chopped wave lightning impulse test (LIC)

The wave shape of the full wave impulses shall be as given in 5.2.8.5. The chopped wave lightning impulse shall have a time chopping between $3 \mu\text{s}$ and $6 \mu\text{s}$. The time to first voltage zero after the instant of chopping shall be as short as possible. Each test shall comprise three voltage applications of positive polarity and three voltage applications of negative polarity, at the required value.

NOTE As an alternative, this requirement can be fulfilled carrying out a full wave lightning impulse test with the test values of the chopped wave lightning test.

5.2.8.7 Switching impulse test (SI)

This test is applicable to on-load tap-changers of U_m 100 kV and above. The test shall be made between the live and earthed parts of the on-load tap-changer. The test configuration shall be stated by the on-load tap-changer manufacturer. The impulse shape shall be 250/2500 as specified in IEC 60060-1. Each test shall comprise three voltage applications of positive polarity and three voltage applications of negative polarity, at the required value.

5.2.8.8 Applied voltage test (AV)

The test shall be performed with a single-phase alternating voltage in accordance with IEC 60060-1, at the required value. The duration of each test application shall be 60 s.

5.2.8.9 Measurement of partial discharges

This test is not required on class I tap-changers.

For class II on-load tap-changers a test shall also be made between live parts and earthed parts of the tap-changer.

For class II on-load tap-changers combining more than one phase in one unit (see example in IEC 60214-2) a test shall be made between the phases, which are adjacent in the tap-changer. The test sequence described below can be used for measurement of partial discharges between phases as well, however, the reference value $U_m / \sqrt{3}$ shall be exchanged with U_m .

The test configuration shall be stated by the on-load tap-changer manufacturer. The screening of terminals to which tap leads will be connected is permissible.

The test shall be performed with a single-phase alternating voltage in accordance with IEC 60060-1.

The test sequence shall be as follows:

- the voltage shall be switched on at a level not higher than $0,4 U_m / \sqrt{3}$;
- the background PD measurement shall be measured and recorded;
- the voltage shall be raised to $1,2 U_m / \sqrt{3}$ and held there for a minimum duration of 1 min;
- the PD level shall be measured and recorded;
- the voltage shall be raised to $1,58 U_m / \sqrt{3}$ and held there for a minimum duration of 5 min;
- the PD level shall be measured and recorded;
- the voltage shall be raised to the enhancement voltage $1,8 U_m / \sqrt{3}$ and held there for a duration of 60 s in case $U_m \leq 800$ kV and 300 s in case $U_m > 800$ kV;
- immediately after the test time, the voltage shall be reduced without interruption to $1,58 U_m / \sqrt{3}$;
- the PD level shall be measured and recorded;
- the voltage shall be held at $1,58 U_m / \sqrt{3}$ for a duration of at least 60 min;
- the PD level shall be measured and recorded every 5 min during the 60 min period;
- after the last PD measurement in the 60 min period, the voltage shall be reduced to $1,2 U_m / \sqrt{3}$ and held there for a minimum duration of 1 min;
- the PD level shall be measured and recorded;
- the voltage shall be reduced to $0,4 U_m / \sqrt{3}$;
- the background PD measurement shall be measured and recorded;
- the voltage shall be reduced to a value below $0,4 U_m / \sqrt{3}$;
- the voltage shall be switched off.

The partial discharge level shall be continuously observed on at least one measuring channel for the entire duration of test.

The duration of the test shall be as shown in Figure 2.

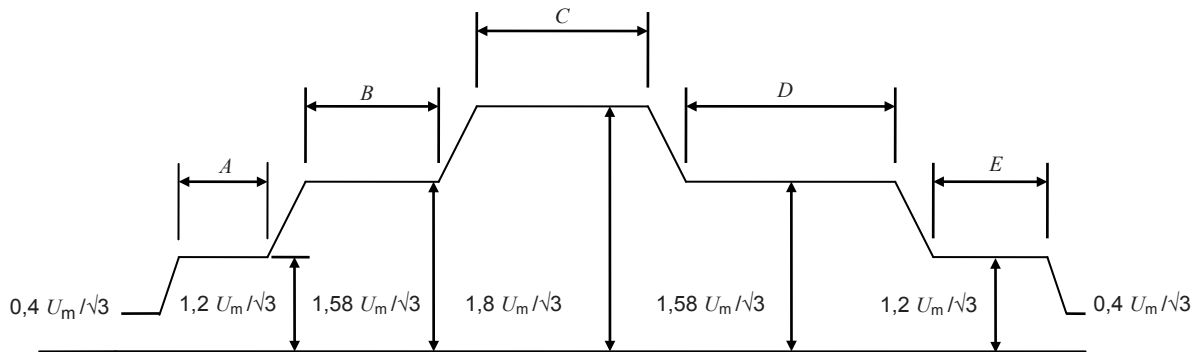

IEC 1785/14

Key $A = 1 \text{ min}$ $B = 5 \text{ min}$ $C = 60 \text{ s}$ in case $U_m \leq 800 \text{ kV}$ and 300 s in case $U_m > 800 \text{ kV}$ $D = 60 \text{ min}$ $E = 1 \text{ min}$ **Figure 2 – Time sequence for the application of test voltage (on-load tap-changer)**

Partial discharges shall be measured by a method according to IEC 60270.

Each PD measurement channel including the associated coupling capacitor shall be calibrated in terms of apparent charge (pC) according to the method given in IEC 60270.

The PD measurement shall be given in pC and shall refer to the highest steady-state repetitive impulses indicated by the measuring instrument.

Occasional bursts of high PD level may be disregarded.

The test can only be considered valid if the measured background PD level does not exceed 10 pC at both the beginning and the end of the test.

The test is successful if all the following criteria are fulfilled:

- no collapse of the test voltage occurs;
- the continuous level of partial discharges does not exceed 50 pC during the 60 min period (duration D);
- the PD behaviour shows no continuously rising tendency and no sudden sustained increase in the levels occur during the last 20 min of the 60 min period (duration D);
- the PD level at a voltage of $1,2 U_m/\sqrt{3}$ after the 60 min period does not exceed 30 pC.

If the criterion c) is not met, the 60 min period may be extended and this criterion will be considered to have been met if it is fulfilled for a continuous period of 60 min.

NOTE The above test procedure is equivalent to the partial discharge test specified in 11.3 of IEC 60076-3:2013.

5.2.9 Type-test certificate

The certificate shall include:

- full details of the test arrangements adopted (for example, assembly, arrangement and drying out) with explanatory sketches as necessary;
- full details of all tests applied in accordance with 5.2.2 to 5.2.8;
- full details of limiting devices for transient overvoltages, where appropriate, see 5.1.5;
- photographs of all contacts breaking and commutating currents.

The erosion of the contacts in the vacuum interrupters and any other current commutating contacts shall be presented and shall not exceed the limits according to the manufacturer's specifications. No signs of arcs on contacts not intended to have arcs are allowed.

5.3 Routine tests

5.3.1 General

The following routine tests shall be performed on each completed on-load tap-changer:

- mechanical test (5.3.2);
- sequence test (5.3.3);
- auxiliary circuits insulation test (5.3.4);
- pressure and vacuum tests (5.3.5).

NOTE Attention is drawn to tests to be carried out on on-load tap-changers after assembly on transformers, which are detailed in 11.7 of IEC 60076-1:2011.

5.3.2 Mechanical test

With the on-load tap-changer fully assembled but without the contacts energized, ten complete cycles of operation shall be performed without failure.

5.3.3 Sequence test

During the routine mechanical test in 5.3.2, a sequence of operations of the on-load tap-changer shall be recorded, the operation of the diverter or selector switch being recorded oscillographically. The results of this recording shall be substantially in agreement with those of the sequence type test from 5.2.6.3.

5.3.4 Auxiliary circuits insulation test

The tap-changer auxiliary circuits shall withstand without failure a separate source a.c. withstand voltage test of 2 kV applied for 1 min between all live terminals and the frame.

5.3.5 Pressure and vacuum tests

All liquid or gas containing compartments shall be tested at a pressure and vacuum declared by the manufacturer.

6 Requirements for motor-drive mechanisms for on-load tap-changers

6.1 General requirements

6.1.1 Compliance of component parts

Unless otherwise specified, component parts of motor-drive mechanisms shall comply with the relevant IEC standard.

6.1.2 Permissible variation of auxiliary supply

The driving motor and the control equipment of the motor-drive mechanism shall be designed to operate satisfactorily between 85 % and 110 % of the rated supply voltage (a.c. and d.c. voltage), the frequency, in the case of a.c. voltage, being the rated supply frequency.

The standard values of rated a.c. supply frequency are 50 Hz and 60 Hz.

6.1.3 Step-by-step control

The step-by-step circuit shall be designed in such a way as to operate the on-load tap-changer by one complete voltage step only in the case of signals which may be continuous or immediately repetitive as well as simultaneous from separate sources within one tap-change operation. This requirement applies also in the case of earth faults or interruption of a control wire.

6.1.4 Tap position indicator

Clear and reliable indication of the tap position of the on-load tap-changer shall be provided. It shall be possible to easily check the state of the tap position of the position-indicating device when operating locally.

If required, a remote position transmitter may be provided for indicating the tap position at a remote location.

6.1.5 Tap-change in progress indication

If required, a suitable device may be fitted to operate a means of indicating at a remote point that the motor-drive mechanism is performing a tap-change operation.

6.1.6 Limiting devices

The limiting device shall prevent the overrun of the permissible operation range of the on-load tap-changer.

The motor-drive mechanism shall be provided with a limiting device that prevents an effect of control impulses beyond the end position and stops the drive in case of initiation of a tap-change operation beyond the end position respectively.

Additionally, a mechanical limit device shall be incorporated in either the on-load tap-changer or the motor-drive mechanism. No damage shall be caused when reaching the mechanical end stop.

6.1.7 Parallel control devices

Provision of the necessary devices shall be agreed, the purchaser being responsible for ensuring that the correct requirements are specified.

6.1.8 Direction of rotation protection

If required, a device for the prevention of incorrect rotation of three-phase motors may be fitted by agreement between the manufacturer and purchaser.

6.1.9 Overcurrent blocking device

If required by the operational conditions of the transformer, an overcurrent blocking device may be fitted by agreement between manufacturer and purchaser.

6.1.10 Restarting device

If required, a device may be provided which, after a possible interruption of the supply voltage, will complete a tap-change operation once it has been initiated.

6.1.11 Operation counter

Operation counters shall be suitable for their intended duty in terms of environmental conditions and for the number of operations specified for the on-load tap-changer. The number of operations of the on-load tap-changer can be provided as an electrical information (stored in a memory) or with a six-figure or greater non-resettable counter.

If required, a device indicating the number of operations shall be provided (in case of electrical information).

6.1.12 Manual operation of the motor-drive mechanism

A device shall be provided which, in the event of power supply failure of the motor-drive mechanism, facilitates a tap-change operation of the on-load tap-changer. The device shall ensure a blocking of the motor-drive mechanism to prevent unintended operation (e.g. remote control, voltage recovery, etc.).

The direction of rotation and further instructions shall be indicated adjacent to the point of engagement.

The design of the device should permit the operation by one person without undue effort.

NOTE This subclause does not apply to step-voltage regulators as defined in IEC 60076-21.

6.1.13 Motor-drive cubicle

The motor-drive cubicle shall meet the protection requirements of IP44 according to IEC 60529 and shall be protected against condensation by suitable means.

If required, higher degrees of protection according to IEC 60529 may be agreed between manufacturer and purchaser.

6.1.14 Protective device against running-through

A device to prevent the motor-drive mechanism from running through in case of failure of the step-by-step control circuit shall be provided.

6.1.15 Protection against access to hazardous parts

Driving mechanism cubicles fitted with doors shall continue to provide protection to at least category IP1X (according to IEC 60529) with any door open.

NOTE This will provide protection against accidental "back of the hand" contact as a minimum.

External drive shafts shall be protected with guards.

6.2 Type tests

6.2.1 Mechanical load test

The motor-drive mechanism output shaft shall be loaded by the largest torque on-load tap-changer for which it is designed or by an equivalent simulated load torque cycle, based on service conditions. At such a load, 500 000 operations shall be performed across the whole tap range.

Additional cooling of the motor-drive is permissible during this test.

During this test, performed at rated frequency:

- 10 000 operations shall be performed at the minimum voltage as specified in 6.1.2;
- 10 000 operations at the maximum voltage as specified in 6.1.2;
- 100 operations shall be performed at a temperature of -25 °C . The temperature inside the motor-drive cabinet when the test starts shall be not higher than -25 °C . The motor-drive mechanism shall be tested at rated voltage and rated frequency. The temperature inside the cabinet shall be measured during the test and stated in the test report.

The correct functioning of the devices covered by 6.1.6, 6.1.10, 6.1.11, 6.1.12 and 6.1.14 shall be verified during this test. The test shall be completed without failure or any undue wear of the mechanical parts.

Normal maintenance according to the manufacturer's handbook is permitted during the test.

During the test, the heating system of the motor-drive mechanism shall be switched off.

6.2.2 Overrun test

It shall be demonstrated that in the event of a failure of the limiting device of the motor-drive mechanism, the additional mechanical limiting device of the motor-drive mechanism or the on-load tap-changer prevent operation beyond the end positions when a motorized tap-change operation is performed. No electrical or mechanical damage shall occur.

6.2.3 Degree of protection of motor-drive cubicle

When applicable, the motor-drive cubicle shall be tested in accordance with IEC 60529.

6.3 Routine tests

6.3.1 Mechanical tests

The motor-drive mechanism in the service condition or with an equivalent simulated load shall be operated electrically for ten cycles of operation without failure. During this test, correct functioning in accordance with any requirements of 6.1.6, 6.1.10, 6.1.11, 6.1.12 and 6.1.14 shall be checked.

After the above test, two further cycles of operation shall be performed, one at the minimum and one at the maximum level of the rated voltage of the auxiliary supply. These shall be performed without failure.

NOTE The mechanical tests can be performed on the motor-drive mechanism separately or as in 5.3.2.

6.3.2 Auxiliary circuits insulation test

Auxiliary circuits, except the motor and other elements which are to be tested with lower test voltages according to the appropriate IEC standards, shall be subjected to a separate source a.c. withstand test of 2 kV r.m.s applied for 1 min between all live terminals and the frame.

7 Requirements for de-energized tap-changers

7.1 General requirements

7.1.1 Rated characteristics

The rated characteristics are as follows:

- maximum rated through-current;
- maximum rated step voltage;
- rated frequency;
- rated insulation level.

7.1.2 Types

De-energized tap-changers may comprise of hand or motor-drive operated mechanical rotary or linear switches.

7.1.3 Handles and drives

Handles used as drive mechanisms are typically hand-wheels or hand cranks and are either directly fitted to the de-energized tap-changer for transformer lid mounting, fitted to the de-energized tap-changer head cover or fitted to a remote gland housing mounted on the outside of the transformer. In the latter case, they are connected to the de-energized tap-changer for example by means of drive shafts or cables.

The operating handle for hand operated de-energized tap-changers shall be mounted externally.

The tap position shall be clearly indicated when the de-energized tap-changer is fully on position. The direction of rotation for raising and lowering the tap position shall be clearly indicated. In addition, the number of rotations for one tap-change operation shall be given where applicable.

A system shall be provided to positively latch the DETC in service position to carry full operating current.

7.1.4 Glands

All sealing glands of the de-energized tap-changer between the liquid or gas filled transformer or tap-changer tank and the environment shall be liquid or gas tight.

7.1.5 Interlocks

A safety device shall be provided to prevent the equipment from being actuated unintentionally or by unauthorized personnel. Such a device may consist of a locking device at the manual drive mechanism which requires a deliberate act by the operator to remove it.

Solely when the de-energized tap-changer is in a proper position state, it shall be possible to operate, remove or reinstall the safety device.

If a motor-drive mechanism is used to operate the de-energized tap-changer, preference shall be given to automatic interlocks by means of electrical interlocking circuits.

7.1.6 Mechanical end stops

It shall not be possible to operate the de-energized tap-changer past the end of range to an unselected position. Where the number of selectable positions may vary, mechanical end stops or a mechanical means shall be incorporated into either the selector or the manual drive mechanism to prevent operation past the first and last positions.

7.2 Type tests

7.2.1 General

The following type tests shall be performed on samples of the relevant de-energized tap-changers after their final development or on equivalent components provided that the manufacturer can demonstrate that the relevant test conditions and results are not influenced by testing only components instead of the complete tap-changer.

NOTE No differentiation has to be made with respect to the test supplies with frequencies of 50 Hz or 60 Hz. The tests can be carried out with either frequency.

- temperature rise of contacts (7.2.2);
- short-circuit current test (7.2.3);
- mechanical tests (7.2.4);
- dielectric tests (7.2.5).

7.2.2 Temperature rise of contacts

Tests shall be performed to verify that the temperature rise above the medium surrounding each type of contact which carries current continuously in service does not exceed the values given in Table 4 when the contacts have reached a steady temperature when carrying 1,2 times the maximum rated through-current.

Meeting this condition proves the overload capacity as referred to in 4.3.

When the surrounding medium is liquid, the test shall be performed at a starting liquid temperature of not more than 40 °C and not less than 10 °C.

The temperature of the surrounding medium shall be measured at not less than 25 mm below the contacts.

The temperature shall be measured by thermocouples or other suitable means positioned in a manner to accurately reflect the actual contact temperature as near the point of contact as possible. The measuring device should be embedded into the contact or brazed or welded onto the contact so that it is measuring the bulk temperature of the contact and not the temperature of the interface between contact and cooling medium.

The temperature condition is considered to be steady when the difference of the temperature between the contact and the surrounding medium does not change by more than 1 K over an hour.

The cross-section and insulation of the conductor carrying the current into the de-energized tap-changer or components under test shall be stated.

Table 4 – Contact temperature-rise limits for de-energized tap-changers

Contact material	In air K	In SF ₆ K	In liquid K
Plain copper	25	35	15
Silver-faced copper/alloys	40	35	15
Other materials	By agreement	By agreement	15

In SF₆ the maximum allowable contact temperature under overload conditions is 150 °C. When the temperature of SF₆ is controlled by a specific method, the manufacturer shall specify an allowable contact temperature rise, which takes into consideration reduced SF₆ temperature surrounding the DETC. Subsequent tests by the manufacturer using that method shall verify that the maximum allowable contact temperature of 150 °C will not be exceeded.

7.2.3 Short-circuit current test

All contacts of different design carrying current continuously shall be subject to short-circuit currents, each of 2 s ($\pm 10\%$) duration. In the case of liquid immersed de-energized tap-changers, the test shall be performed in transformer liquid.

In the case of three-phase de-energized tap-changers, it is sufficient to test the contacts of one phase only unless otherwise specified.

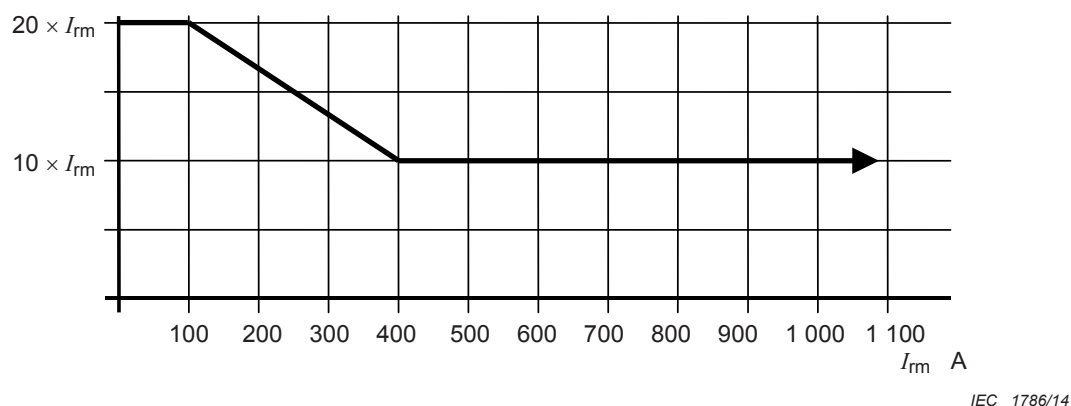

Figure 3 – Short-circuit test current (r.m.s. value) as a multiple of the maximum rated through-current (de-energized tap-changer)

Three applications shall be made with an initial peak current of 2,5 ($\pm 5\%$) times the r.m.s. value of the rated short-circuit test current. The contacts shall not be moved between these applications.

When there are no facilities for point-on-wave switching and it is not possible to obtain three short-circuit applications with initial peak current 2,5 times the r.m.s. value, the following test may be used.

The r.m.s. value of the short-circuit test current may be increased so that the rated peak current is obtained for the three applications and the test duration reduced. When using this method, the product of the square of the increased r.m.s. current and the shorter test duration shall be not less than the product of the square of the rated short-circuit r.m.s. current and the two second duration.

The values of the short-circuit test current to be applied shall be as given in Figure 3.

The open-circuit voltage for the test shall be at least 50 V.

At the conclusion of the test, the contacts shall not have been damaged so as to prevent continuing correct operation at maximum rated through-current. The initial operating torque shall be measured before and after the test and show suitability for service.

Other current-carrying parts shall not show signs of permanent mechanical distortion, which can influence the normal operation of the tap-changer.

7.2.4 Mechanical tests

7.2.4.1 Mechanical endurance test

If the de-energized tap-changer is of liquid-immersed design, it shall be assembled and filled with clean liquid or immersed in a test tank filled with clean liquid, and operated as for normal

service conditions. The contacts shall not be energized and the full range of taps shall be utilized until a minimum of 2 000 tap-change operations have been performed.

For de-energized tap-changers declared suitable for use with a motor-drive mechanism, then 20 000 operations shall be performed.

For compartment type de-energized tap-changers, this test may be performed at ambient temperature. For in-tank de-energized tap-changers, half the number of operations shall be performed at a temperature of not less than 75 °C and half at a lower temperature, for example during the heating or cooling period, with daily temperature cycles being permitted.

During the test, there shall be no failure or undue wear of the contacts or mechanical parts that would lead to mechanical failure if operation continued.

NOTE The surrounding mediums declared suitable for operation can typically be mineral insulating oil, alternative liquids (such as ester fluids (natural or synthetic) or silicon fluids), air and other gases.

7.2.4.2 Pressure and vacuum tests

Appropriate tests shall be performed on all glands and seals to prove pressure and vacuum values. The manufacturer shall declare his values.

7.2.5 Dielectric tests

7.2.5.1 General

The dielectric requirements of a de-energized tap-changer depend on the transformer winding to which it is to be connected.

The transformer manufacturer shall be responsible not only for selecting a de-energized tap-changer of the appropriate insulation level, but also for the insulation level of the connecting leads between the de-energized tap-changer and the windings of the transformer.

De-energized tap-changers for liquid-immersed design shall be filled with clean liquid or immersed in a test tank filled with clean liquid before the tests detailed in 7.2.5.2 are performed.

7.2.5.2 Nature of tests

The insulation level of the de-energized tap-changer shall be proved by dielectric tests performed at the following distances:

- a) to earth;
- b) between phases (where applicable);
- c) between the first and last contacts of the de-energized tap-changer;

NOTE In case of designs, where the fixed contacts are arranged in a straight line, this test is not applicable.

- d) between any two adjacent contacts of the de-energized tap-changer;
- e) any distance that, due to the contact configuration, will have a higher stress than the ones tested above.

7.2.5.3 Test voltages

– Class I

For test a), the test voltages shall comply with appropriate values from Table 5. For tests b), c), d) and e), appropriate withstand values of full and chopped wave lightning impulse voltage, applied voltage and if applicable of switching impulse shall be declared by the manufacturer of the de-energized tap-changer

– Class II

For tests a) and b), test voltage shall comply with the appropriate values from Table 5. For tests c), d) and e), appropriate withstand values of full and chopped wave lightning impulse, applied voltage and if applicable of switching impulse shall be declared by the manufacturer of the de-energized tap-changer.

The values in Table 5 are the highest selected test voltages for U_m and are based on Clause 7 of IEC 60076-3:2013. Table 5 should be used for selecting the test levels for 7.2.5.5 through 7.2.5.9.

Table 5 – Test voltage levels for de-energized tap-changers

Highest voltage for equipment U_m kV	Full wave lightning Impulse kV	Chopped wave lightning Impulse kV	Switching impulse kV	Applied voltage kV
< 1,1	-	-	-	3
3,6	40	44	-	10
7,2	75*	83*	-	20
12	110*	121*	-	34*
17,5	125*	138*	-	38
24	150*	165*	-	50
36	200*	220*	-	70
52	250	275		95
72,5	350*	385*	-	140
100	450	495	375*	185
123	550	605	460*	230
145	650	715	540*	275
170	750	825	620*	325
245	1 050	1 155	850*	460
300	1 050	1 155	850	460
362	1 175	1 290	950	510
420	1 425	1 570	1 175*	630
550	1 675*	1 845*	1 390*	680
800	2 100	2 310	1 675*	-
1 100	2 250	2 475	1 800	-
1 200	2 250	2 475	1 800	-

NOTE Values marked with an asterisk (*) are not given in IEC 60076-1:2011 for the particular value of U_m but are included either because they represent common practice in some parts of the world or for some switching impulse levels, because they represent a co-ordinated value for a particular value of lightning impulse level (see IEC 60076-3:2013).

7.2.5.4 Application of test voltages

For the dielectric tests, the de-energized tap-changer shall be assembled, arranged and dried-out in a manner similar to that in service. It is not, however, necessary to include leads for connecting the de-energized tap-changer to the windings of a transformer. If using leads they should be an approximation of that in service. Tests may be performed on separate components provided it can be shown that the same dielectric conditions apply.

For test a) of 7.2.5.2 when applied to class I and class II de-energized tap-changers and test b) of 7.2.5.2 when applied to class II de-energized tap-changer, the live parts of each phase shall be short-circuited and connected either to the voltage source or to the earth as appropriate.

Where the de-energized tap-changer incorporates external insulation to earth, this external insulation shall be proved in accordance with the relevant tests described in IEC 60137.

The preferred testing sequence is as follows:

- full wave lightning impulse test;
- chopped wave lightning impulse test
- switching impulse test, when required;
- applied voltage test;
- measurement of partial discharges, when required.

7.2.5.5 Full wave lightning impulse test (LI)

The test impulse shall be a full standard lightning impulse ($1,2 \mu\text{s} \pm 30\%$ / $50 \mu\text{s} \pm 20\%$) with a maximum overshoot of 5 %. The tolerance on the test voltage value is $\pm 3\%$. Each test shall comprise three voltage applications of positive polarity and three voltage applications of negative polarity, at the required value.

7.2.5.6 Chopped wave lightning impulse test (LIC)

The wave shape of the full wave impulses shall be as given in 7.2.5.5 The chopped wave lightning impulse shall have a time chopping between $3 \mu\text{s}$ and $6 \mu\text{s}$. The time to first voltage zero after the instant of chopping shall be as short as possible. Each test shall comprise three voltage applications of positive polarity and three voltage applications of negative polarity, at the required value.

NOTE As an alternative, this requirement can be fulfilled carrying out a full wave lightning impulse test with the test values of the chopped wave lightning test.

7.2.5.7 Switching impulse test (SI)

This test is applicable to de-energized tap-changers of U_m 100 kV and above. The test shall be made between the live and earthed parts of the de-energized tap-changer. The test configuration shall be stated by the de-energized tap-changer manufacturer. The impulse shape shall be 250/2500 μs as specified in IEC 60060-1. Each test shall comprise three voltage applications of positive polarity and three voltage applications of negative polarity, at the required value.

7.2.5.8 Applied voltage test (AV)

The test shall be performed with a single-phase alternating voltage in accordance with IEC 60060-1, at the required value. The duration of each test application shall be 60 s.

7.2.5.9 Measurement of partial discharges

This test is not required on class I tap-changers.

For class II de-energized tap-changers a test shall be made between live parts and earthed parts of the tap-changer.

For class II de-energized tap-changers combining more than one phase in one unit (see example in IEC 60214-2) a test shall also be made between the phases, which are adjacent in the tap-changer. The test sequence described below can be used for measurement of partial

discharges between phases as well, however, the reference value $U_m / \sqrt{3}$ shall be exchanged with U_m .

The test configuration shall be stated by the de-energized tap-changer manufacturer. The screening of terminals to which tap leads will be connected is permissible.

The test shall be performed with a single-phase alternating voltage in accordance with IEC 60060-1.

The test sequence shall be as follows:

- the voltage shall be switched on at a level not higher than $0,4 U_m / \sqrt{3}$;
- the background PD measurement shall be measured and recorded;
- the voltage shall be raised to $1,2 U_m / \sqrt{3}$ and held there for a minimum duration of 1 min;
- the PD level shall be measured and recorded;
- the voltage shall be raised to $1,58 U_m / \sqrt{3}$ and held there for a minimum duration of 5 min;
- the PD level shall be measured and recorded;
- the voltage shall be raised to the enhancement voltage $1,8 U_m / \sqrt{3}$ and held there for a duration of 60 s in case $U_m \leq 800$ kV and 300 s in case $U_m > 800$ kV;
- immediately after the test time, the voltage shall be reduced without interruption to $1,58 U_m / \sqrt{3}$;
- the PD level shall be measured and recorded;
- the voltage shall be held at $1,58 U_m / \sqrt{3}$ for a duration of at least 60 min;
- the PD level shall be measured and recorded every 5 min during the 60 min period;
- after the last PD measurement in the 60 min period the voltage shall be reduced to $1,2 U_m / \sqrt{3}$ and held there for a minimum duration of 1 min;
- the PD level shall be measured and recorded;
- the voltage shall be reduced to $0,4 U_m / \sqrt{3}$;
- the background PD measurement shall be measured and recorded;
- the voltage shall be reduced to a value below $0,4 U_m / \sqrt{3}$;
- the voltage shall be switched off.

The partial discharge level shall be continuously observed on at least one measuring channel for the entire duration of test.

The duration of the test shall be as shown in Figure 4.

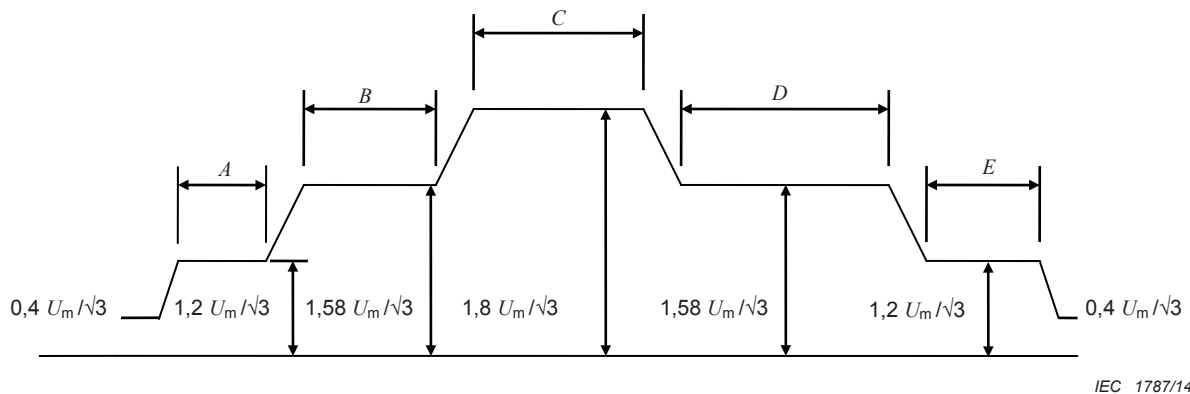

Key

$A = 1 \text{ min}$

$B = 5 \text{ min}$

$C = 60 \text{ s}$ in case $U_m \leq 800 \text{ kV}$ and 300 s in case $U_m > 800 \text{ kV}$

$D = 60 \text{ min}$

$E = 1 \text{ min}$

Figure 4 – Time sequence for the application of test voltage (de-energized tap-changer)

Partial discharges shall be measured by a method according to IEC 60270.

Each PD measurement channel including the associated coupling capacitor shall be calibrated in terms of apparent charge (pC) according to the method given in IEC 60270.

The PD measurement shall be given in pC and shall refer to the highest steady-state repetitive impulses indicated by the measuring instrument.

Occasional bursts of high PD level may be disregarded.

The test can only be considered valid if the measured background PD level does not exceed 10 pC at both the beginning and the end of the test.

The test is successful if all the following criteria are fulfilled:

- a) no collapse of the test voltage occurs;
- b) the continuous level of partial discharges does not exceed 50 pC during the 60 min period (duration D);
- c) the PD behaviour shows no continuously rising tendency and no sudden sustained increase in the levels occurs during the last 20 min of the 60 min period (duration D);
- d) the PD level at a voltage of $1,2 U_m / \sqrt{3}$ after the 60 min period does not exceed 30 pC.

If the criterion c) is not met, the 60 min period may be extended and this criterion will be considered to have been met if it is fulfilled for a continuous period of 60 min.

NOTE The above test procedure is equivalent to the partial discharge test specified in 11.3 of IEC 60076-3:2013.

7.2.6 Type test certificate

The test certificate shall include:

- full details of the test arrangements adopted (for example, assembly arrangements and drying out) with explanatory sketches as necessary;
- full details of all tests applied in accordance with 7.2.2 to 7.2.5.

7.3 Routine tests

7.3.1 Mechanical tests

With the de-energized tap-changer fully assembled but without the contacts energized, two complete cycles of operation shall be performed without failure. During this test any end stops described under 7.1.6 shall be checked for correct operation and setting.

7.3.2 Pressure and vacuum tests

Tests shall be performed on all liquid-tight glands and levels shall be declared by the manufacturer. A declared value of zero indicates this test has not been carried out.

NOTE Pressure and vacuum tests on small de-energized tap-changers are often not carried out.

8 Requirements for motor-drive mechanisms for de-energized tap-changers

8.1 General requirements

8.1.1 General

Motor-drive mechanisms for on-load tap-changers may be used for de-energized tap-changer applications. For de-energized tap-changers, the requirements in 8.1.2 to 8.1.9 as a minimum shall apply.

If a motor-drive mechanism is used to operate the de-energized tap-changer, preference shall be given to automatic interlocks by means of electrical interlocking circuits.

8.1.2 Compliance of component parts

Unless otherwise specified, component parts of motor-drive mechanisms shall comply with the relevant IEC standard.

8.1.3 Permissible variation of auxiliary supply

The driving motor and the control equipment of the motor-drive mechanism shall be designed to operate satisfactorily between 85 % and 110 % of the rated supply voltage (a.c. and d.c. voltage), the frequency, in the case of a.c. voltage, being the rated supply frequency.

The standard values of rated a.c. supply frequency are 50 Hz and 60 Hz.

8.1.4 Tap position indicator

Clear and reliable indication of the tap position of the de-energized tap-changer shall be provided. It shall be possible to easily check the state of the tap position of the position-indicating device when operating locally.

If required, a remote position transmitter may be provided for indicating the tap position at a remote location.

8.1.5 Limiting devices

A mechanical limit device shall be incorporated in either the de-energized tap-changer or the motor-drive mechanism.

8.1.6 Operation counter

Operation counters shall be suitable for their intended duty in terms of environmental conditions and for the number of operations specified for the de-energized tap-changer. The number of operations of the de-energized tap-changer can be provided as an electrical information (stored in a memory) or with a five-figure or greater non-resettable counter.

If required, a device indicating the number of operations shall be provided (in case of electrical information).

8.1.7 Manual operation of the motor-drive mechanism

A device shall be provided which, in the event of power supply failure of the motor-drive mechanism, facilitates a tap-change operation of the de-energized tap-changer. The device shall ensure a blocking of the motor-drive mechanism to prevent unintended operation (e.g. remote control, voltage recovery, etc.).

The direction of rotation and further instructions shall be indicated adjacent to the point of engagement.

The design of the device should permit the operation by one person without undue effort.

8.1.8 Motor-drive cubicle

The motor-drive cubicle shall meet the protection requirements of IP44 according to IEC 60529 and shall be protected against condensation by suitable means.

If required, a higher degree of protection according to IEC 60529 may be agreed between manufacturer and purchaser.

8.1.9 Protection against access to hazardous parts

Driving mechanism cubicles fitted with doors shall continue to provide protection to at least category IP1X according to IEC 60529 with any door open.

NOTE This will provide protection against accidental “back of the hand” contact as a minimum.

External drive shafts shall be protected with guards.

8.2 Type tests

8.2.1 Mechanical load test

The motor-drive mechanism output shaft shall be loaded by the greatest torque for the de-energized tap-changer for which it is designed or by an equivalent simulated load torque cycle, based on service conditions. At such a load, 20 000 operations shall be performed across the whole tap range.

Additional cooling of the motor-drive is permissible during this test.

During this test, performed at rated frequency:

- 1 000 operations shall be performed at the minimum voltage as specified in 8.1.3;
- 1 000 operations shall be performed at the maximum voltage as specified in 8.1.3;

- 50 operations shall be performed at a temperature of -25 °C . The temperature inside the motor-drive cabinet when the test starts shall be -25 °C . The motor-drive mechanism shall be tested at rated voltage and rated frequency. The temperature inside the cabinet shall be measured during the test and stated in the test report.

The correct functioning of the device covered by 8.1.5, 8.1.6, and 8.1.7 shall be verified during this test. The test shall be completed without failure or any undue wear of the mechanical parts.

Normal maintenance according to the manufacturer's handbook is permitted during the test.

During the test, the heating system of the motor-drive mechanism shall be switched off.

8.2.2 Overrun test

It shall be demonstrated that in the event of a failure of the electrical limit switches, the mechanical end stops prevent operation beyond the end positions when a motorized tap-change is performed and that the motor-drive mechanism will not suffer either electrical or mechanical damage.

8.2.3 Degree of protection of motor-drive cubicle

When applicable, the motor-drive cubicle shall be tested in accordance with IEC 60529.

8.3 Routine tests

8.3.1 Mechanical tests

The motor-drive mechanism in the service condition or with an equivalent simulated load shall be operated electrically for two cycles of operation without failure. During this test, correct functioning in accordance with requirements of 8.1.5, 8.1.6 and 8.1.7 shall be checked.

After the above test two further cycles of operation shall be performed, one at the minimum and one at the maximum level of the rated voltage of the auxiliary supply. These shall be performed without failure.

NOTE The mechanical tests can be performed on the motor-drive mechanism separately or as in 7.3.1.

8.3.2 Auxiliary circuits insulation test

Auxiliary circuits, except the motor and other elements which are to be tested with lower test voltages according to the appropriate IEC standards, shall be subjected to a separate source a.c. withstand test of 2 kV r.m.s. applied for 1 min between all live terminals and the frame.

9 Nameplate

9.1 Tap-changers (on-load and de-energized)

Each tap-changer shall be provided with a nameplate of weatherproof material fitted in a visible position showing at least the following items:

- number and year of the relevant national standard and/or this IEC standard;
- the manufacturer's name;
- the manufacturer's serial number;
- the manufacturer's type designation;
- the year of manufacture;
- the rated through-current;

- the rated step voltage (if applicable);
- the transition resistor value (if applicable);
- static vacuum and pressure capabilities of the tap-changer.

The entries shall be indelibly marked, for example by etching, engraving, stamping or by a photo-chemical process.

NOTE For small de-energized tap-changers where size makes it impracticable to fit all of the above information on a nameplate, either a separate loose nameplate can be supplied or the information can be provided in the manufacturers' instructions.

9.2 Motor-drive mechanisms

Each motor-drive mechanism shall be provided with a nameplate of weatherproof material fitted in a visible position showing the appropriate items listed in 9.1. In addition, if appropriate, the nameplate shall show the following information:

- the rated voltage and rated frequency of the electric motor;
- the rated voltage and rated frequency of the control equipment;

NOTE In the case of a d.c. supply, the symbol --- can be used instead of the indication of the rated frequency.

- the number of service tap positions.

The entries shall be indelibly marked, for example by etching, engraving, stamping or photo-chemical process.

10 De-energized tap-changer warning label

For de-energized tap-changers, a warning label or instruction shall either be attached to the tap-changer or supplied as a separate label which shall be fitted adjacent to the operating handle. Figure 5 shows an example of such a warning label. The minimum and necessary requirement for a warning label is that operating the DETC is only allowed if the transformer is de-energized.

The conformity of the warning label (e.g. drawing, symbols) with local or national law is in the responsibility of the transformer manufacturer.

The transformer manufacturer is responsible to fit an appropriate warning label that is clearly visible, near the operating mechanism of the DETC on the transformer.

A similar label shall be attached to motor-drive mechanisms.

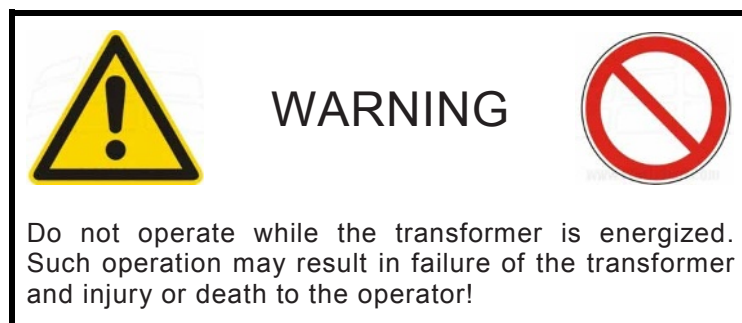

IEC 1788/14

Figure 5 – Warning label (example)

11 Manufacturers operating instructions

The manufacturer shall provide a handbook to facilitate the safe and proper operation of the tap-changer including maintenance criteria.

The handbook shall cover but not be limited to installation, operation, maintenance criteria and in addition identify any inherent dangers or risks (for example, electric shock, stored energy devices, unexpected starting of the mechanism following interruption of supply, etc.).

Annex A (normative)

Supplementary information on switching duty on main and transition contacts relating to resistor type tap-changers

Tables A.1 and A.3 show typical contact arrangements used for diverter and selector switches. Only one pair of contacts is shown for each function, although in practice this may represent a set of contacts.

Tables A.1 and A.3 also show the number of circuit-transfer operations performed together with the duty performed by each pair of contacts for each combination of switched current and recovery voltage during a number of cycles of operation corresponding to N tap-change operations.

In the expressions for current and voltage in Tables A.1 and A.3, the '+' and '-' signs indicate vectorial addition and subtraction, not algebraic. The duty on the contacts is consequently affected by the power-factor of the load on the transformer, which controls the phase angle between the through-current I and the step voltage E . The effect of the load power-factor on the duty of the various contacts is shown in Table A.2 for non-vacuum type on-load tap-changers and for vacuum type on-load tap-changers in Note 2 of Table A.3.

Additionally, Table A.3 shows not only the breaking stresses for the VIs of vacuum-type on-load tap-changers, but also the making stresses, which are of importance for this kind of tap-changers. The effect of the load power-factor on the duty of the various contacts of vacuum type tap-changers is mentioned in Note 2 of Table A.3.

If the transition impedance is divided into two units, these are assumed to be of equal value, each equal to R .

The arrangements shown in Figure A.1 are by no means exhaustive. Other possible arrangements exist and are used, such as the multiple resistor cycle, which may be an extension of the above-mentioned basic principles.

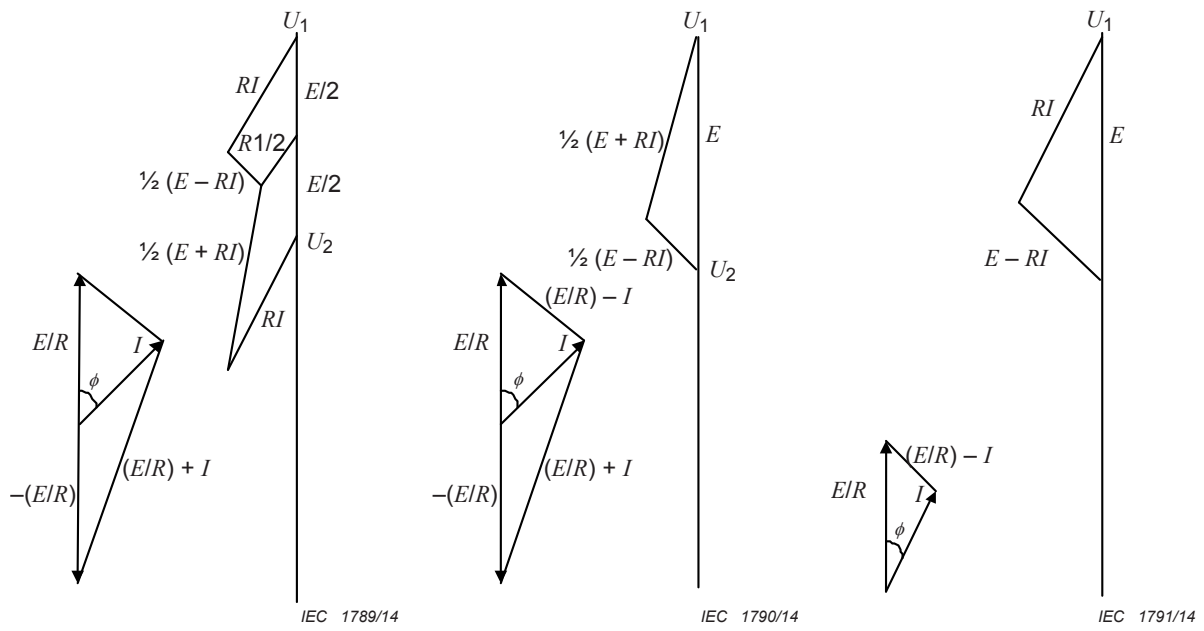

Figure A.1a – Diverter or selector switch with operating cycle number 1

Figure A.1b – Diverter switch with operating cycle number 2

Figure A.1c – Selector switch with operating cycle number 2

NOTE The numbering of the operating cycles only refers to Table A.1.

Figure A.1 – Examples of current and voltage vectors for resistor type tap-changers

Table A.1 – Duty of main and transition contacts for resistor type tap-changers (non-vacuum type)

Type of switch	Operating cycle number	Diagram of connections	Contact operating order	Duty of main contact				Duty of transition contact			
				Contact	Switching current	Recovery voltage	Number of operations	Contact	Switching current	Recovery voltage	Number of operations
Non-vacuum diverter switch	1		W breaks	I	RJ	$N/2$	X	$\frac{1}{2}(E/R + I)$	$E + RI$	$N/4$	
			Y makes								
			X breaks								
			Z makes								
	2		L makes	$E/R + I$	$\frac{1}{2}(E + RI)$	$N/4$	K	E/R	E	$N/2$	
			J breaks	$E/R - I$	$\frac{1}{2}(E - RI)$	$N/4$					
			M makes	$E/R + I$	$\frac{1}{2}(E + RI)$	$N/4$	L	E/R	E	$N/2$	
			K breaks	$E/R - I$	$\frac{1}{2}(E - RI)$	$N/4$					
Non-vacuum selector switch	1		C breaks	I	RJ	N	A	$\frac{1}{2}(E/R + I)$	$E + RI$	$N/2$	
			B breaks								
			C makes								
			A breaks								
	2		B makes	$E/R + I$ or $E/R - I$ (NOTE 3)	$E + RI$ or $E - RI$ (NOTE 3)	$N/2$ or $N/2$ (NOTE 4)	C	$\frac{1}{2}(E/R - I)$	$E - RI$	$N/2$	
			A makes								
			T breaks	I	RJ	$N/2$	S	E/R	E	$N/2$	
			T makes								

NOTE 1 Other circuits involving multiple resistors are not included as they are extensions of the above basic circuits.

NOTE 2 For the purpose of clarity, the diagram of connections and contact operating order are given for one direction of movement of the switch. The expressions for contact duty and number of operations, however, take into account the movement of the switch in both directions.

NOTE 3 Duties depend on the power flow direction and are given here for both directions.

NOTE 4 The number of operations is given under the condition that the power flow will not change.

**Table A.2 – Effect of load power-factor on circuit-breaking duty
for resistor type tap-changers (non-vacuum type)**

Type of switch	Operating cycle number	Main contacts		Transition contacts	
		Contact	Effect of load power-factor	Contact	Effect of load power-factor
Non-vacuum type diverter switch	1	W and Z	None	X and Y	Maximum duty at power-factor = 1,0
	2	J and M	Maximum duty at power-factor = 1,0	K and L	None
Non-vacuum type selector switch	1	B	None	A and C	Maximum duty at power-factor = 1,0
	2	T	None for $N/2$ operations Maximum duty at power-factor = 0 for $N/2$ operations	S	None

NOTE Non-vacuum type selector switches employing the operating cycle number 2 are normally used with load current flow in one direction only.

Table A.3 – Duty of main and transition contacts for resistor type tap-changers (vacuum type) (1 of 2)

Type of switch	Operating cycle number	Diagram of connections	Contact operating order				Duty of main contact V_m					Duty of transition contact $V_t, V_{to}, V_{te}, V_{t1}, V_{t2}$									
			Changing from S_0 to S_e or from r_i to r_{i+1}	Changing from S_e to S_0 or from r_{i+1} to r_i	Switching current	Recovery voltage	Closing current	Closing voltage	Number of operations	Contact	Switching current	Recovery voltage	Closing current	Closing voltage	Number of operations						
Diverter switch (with one transition resistor)	1		V_m breaks	V_m makes	I	RI	$E/R+I$	$E+RI$	$E/R+I$	E	0	0	E/R	$N/2$	V_t	E/R	E	0	E	0	N
			A_a transfers	V_m breaks	V_m makes	$E/R-I$	$E-RI$	$E/R-I$	$E-RI$	$E/R-I$	E	0	E/R	E							
Diverter switch (with one transition resistor)	2		V_m breaks	V_m makes	$E/R+I$	$E+RI$	I	RI	$E/R+I$	$E+RI$	I	RI	E/R	$N/2$	V_t	0	E/R	E	E	N	
			A_a transfers	V_m breaks	V_m makes	$E/R-I$	$E-RI$	$E/R-I$	$E-RI$	$E/R-I$	E	0	E/R	E							$N/2$
Selector switch (NOTE 3)	1		V_m breaks	V_m makes	I	RI	$E/R+I$	$E+RI$	$E/R+I$	E	$E/R+I$	$E+RI$	$E/R+I$	$N/2$	V_t	E/R	E	0	E	0	$N/2$
			S_1 transfers	V_m breaks	V_m makes	$E/R-I$	$E-RI$	$E/R-I$	$E-RI$	$E/R-I$	E	0	E/R	E							
Diverter switch (with two transition resistors)	1		V_m breaks	V_m makes	I	RI	$E/R+I$	$E+RI$	$E/R+I$	E	$E/R+I$	$E+RI$	$E/R+I$	N	V_{to}	E/R	E	$E/R+I$	E	0	$N/2$
			A_a transfers	V_m breaks	V_m makes	$E/R-I$	$E-RI$	$E/R-I$	$E-RI$	$E/R-I$	E	0	E/R	E							
Diverter switch (with two transition resistors)	2		V_m breaks	V_m makes	$E/R+I$	$E+RI$	I	RI	$E/R+I$	$E+RI$	I	RI	$E/R+I$	N	V_{te}	E/R	E	$E/R+I$	E	0	$N/2$
			A_a transfers	V_m breaks	V_m makes	$E/R-I$	$E-RI$	$E/R-I$	$E-RI$	$E/R-I$	E	0	E/R	E							
Selector switch (with two transition resistors)	1		V_m breaks	V_m makes	I	RI	$E/R+I$	$E+RI$	$E/R+I$	E	$E/R+I$	$E+RI$	$E/R+I$	N	V_{t1}	E/R	E	$E/R+I$	E	0	$N/2$
			S_1 transfers	V_m breaks	V_m makes	$E/R-I$	$E-RI$	$E/R-I$	$E-RI$	$E/R-I$	E	0	E/R	E							
Selector switch (with two transition resistors)	1		V_m breaks	V_m makes	$E/R+I$	$E+RI$	I	RI	$E/R+I$	$E+RI$	I	RI	$E/R+I$	N	V_{t2}	E/R	E	$E/R+I$	E	0	$N/2$
			S_1 transfers	V_m breaks	V_m makes	$E/R-I$	$E-RI$	$E/R-I$	$E-RI$	$E/R-I$	E	0	E/R	E							

Table A.3 (2 of 2)

<p>Key</p> <p>E is the step voltage</p> <p>I is the load current</p> <p>S_o, S_e are the tap selector contacts</p> <p>S_m, S_{t1}, S_{t2} are selector contacts of a selector switch</p> <p>V_m is the main contact (vacuum interrupter)</p> <p>$V_t, V_{to}, V_{te}, V_{t1}, V_{t2}$ are the transition contacts (vacuum interrupters)</p> <p>A_m, A_t are the auxiliary transfer switches</p>
<p>NOTE 1 The above circuits with 1 or 2 transition resistors and 2 or 3 vacuum interrupters are the most basic and typical circuits for vacuum type tap-changers. Other circuits involving multiple resistors and more number of vacuum interrupters are not included as they are extensions of the above basic circuits.</p> <p>NOTE 2 Duties including $(E/R+I)$ will be maximum at power-factor = 1,0, duties including $(E/R-I)$ will be maximum at power-factor = 0 and duties including neither $(E/R+I)$ or $(E/R-I)$ are not affected by the power-factor.</p> <p>NOTE 3 The given contact duties in the upper row are valid for one switching direction, the duties given in the lower row are valid for the opposite direction.</p> <p>NOTE 4 Duties depends on the power flow direction and are given here for both directions.</p> <p>NOTE 5 The number of operations is given under the condition that the power flow direction will not change.</p>

Annex B (normative)

Supplementary information on switching duty relating to reactor type tap-changers

B.1 Additional test parameters

B.1.1 Service duty test

The requirements in 5.2.3.2 apply with the following provisions:

- a) preventive auto-transformer: circulating current in bridging position equal to 50 % of the rated through-current or as otherwise specified by the manufacturer and stated in the design test report;
- b) power factor: 80 %.

B.1.2 Breaking capacity test

- a) The requirements in 5.2.3.3 apply with the following provisions:
- b) preventive auto transformer: circulating current in bridging position equal to 50 % of the rated through-current or as otherwise specified by the manufacturer and stated in the design test report;
- c) power factor: 0 %;
- d) number of operations: 40.

B.2 Duty of switching contacts

Tables B.1 to B.4 respectively, show the duty on switching contacts for reactor type tap-changers with the following types of switching:

- selector switch;
- selector switch and equalizing winding;
- diverter switch and tap selector;
- vacuum interrupter and tap selector.

Similarly, Figures B.1 to B.8 show the sequence and vector diagrams for the four types of reactor type tap-changers.

Table B.1 – Duty of switching contacts for reactor type tap-changers with selector switch – Switching direction from P1 to P5

Operating sequence (NOTE 1)	Contact operation	Contact	Switching current	Recovery voltage
P1 On tap 1	N/A	G	-	-
		H	-	-
P2 Transition to bridging (selector switch opens)	H breaks	G	-	-
		H	$\frac{1}{2}I$ (NOTE 2)	$\frac{1}{2}IZ$
P3 Bridging taps 1 and 2	H makes	G	-	-
		H	-	-
P4 Transition to on-tap 2	G breaks	G	$\frac{1}{2}I + E_T/Z$ (NOTE 3)	$E_T + \frac{1}{2}IZ$
		H	-	-
P5 On tap 2	G makes	G	-	-
		H	-	-

NOTE 1 P1, P3 and P5 are service tap positions.

NOTE 2 I is the load current.

NOTE 3 E_T/Z is equal to I_C , the circulating current, Z is the impedance of the preventive autotransformer and E_T is the tap voltage.

NOTE 4 When the transition to on-tap is in the reverse direction, that is, from P5 to P1, the switching current at the G contact is $\frac{1}{2}I$ and the corresponding recovery voltage is $\frac{1}{2}IZ$ (P4). The switched current at H contact is $E_T/Z - \frac{1}{2}I$ and the corresponding recovery voltage is $E_T - \frac{1}{2}IZ$ (P2).

NOTE 5 See Figure B.1 for the operating sequence diagrams and Figure B.2 for the vector diagrams.

NOTE 6 All additions shown in the table are vector additions.

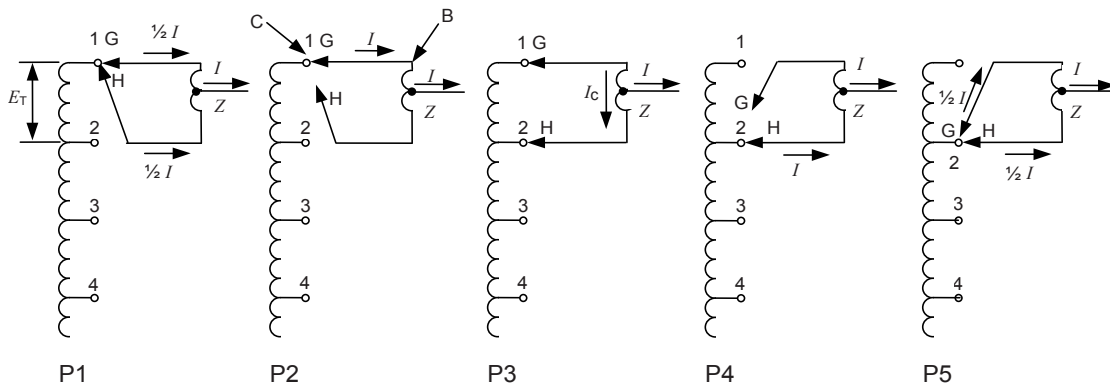

IEC 1792/14

Key

B is the reactor

C is the selector switch (2 in total)

Figure B.1 – Operating sequence of reactor type tap-changers with selector switch

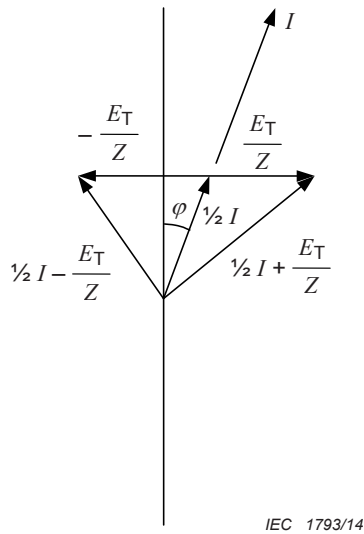

Figure B.2a – Current

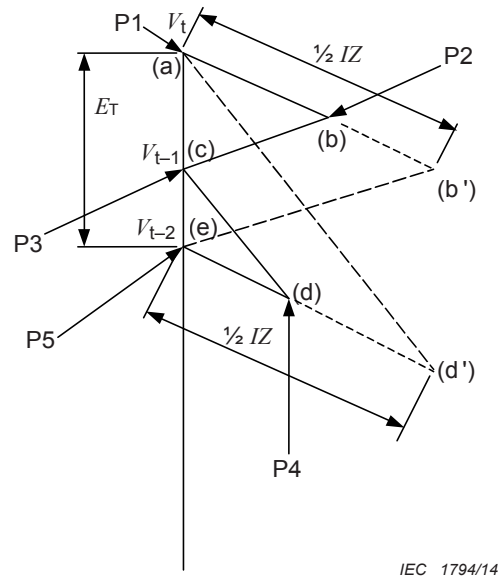

Figure B.2b – Voltage

NOTE 1 System voltage progression during transition steps for two tap position change operations are shown in brackets (a) to (e) in Figure B.2b. Points (a), (c) and (e) represent quiescent operation. Points (b) and (d) represent momentary operations due to reactance drop.

NOTE 2 Vectors (a-b') and (e-d') represent reactor voltage due to transformer action.

NOTE 3 Shown for $|E_T/Z| \cong 0,5|I|$.

Figure B.2 – Current and voltage vectors for reactor type tap-changers with selector switch

Table B.2 – Duty of switching contacts for reactor type tap-changers with selector switch and equalizer windings – Switching direction from P1 to P5

Operating sequence (NOTE 1)	Contact operation	Contact	Switching current	Recovery voltage
P1 On tap 1	N/A	G	-	-
		H	-	-
P2 Transition to bridging (selector switch opens)	H breaks	G	-	-
		H	$\frac{1}{2}I + \frac{1}{2}E_T/Z$ (NOTE 2)	$\frac{1}{2}IZ + \frac{1}{2}E_T$
P3 Bridging taps 1 and 2	H makes	G	-	-
		H	-	-
P4 Transition to on-tap 2	G breaks	G	$\frac{1}{2}I + \frac{1}{2}E_T/Z$ (NOTE 3)	$\frac{1}{2}E_T + \frac{1}{2}IZ$
		H	-	-
P5 On tap 2	G makes	G	-	-
		H	-	-

NOTE 1 P1, P3 and P5 are service tap positions.

NOTE 2 I is the load current.

NOTE 3 $\frac{1}{2} E_T/Z$ is equal to I_C , the circulating current, Z is the impedance of the preventive autotransformer and E_T is the tap voltage. $\frac{1}{2} E_T$ is the equalizer winding voltage.

NOTE 4 When the transition to on-tap is in the reverse direction, that is, from P5 to P1, the switching current at the G contact is $\frac{1}{2} E_T/Z - \frac{1}{2}I$ and the corresponding recovery voltage is $\frac{1}{2} E_T - \frac{1}{2}IZ$ (P4). The switched current at the H contact is $\frac{1}{2} E_T/Z - \frac{1}{2}I$ and the corresponding recovery voltage is $\frac{1}{2} E_T - \frac{1}{2}IZ$ (P2).

NOTE 5 See Figure B.3 for the operating sequence diagrams and Figure B.4 for the vector diagrams.

NOTE 6 All additions shown in the Table are vector additions.

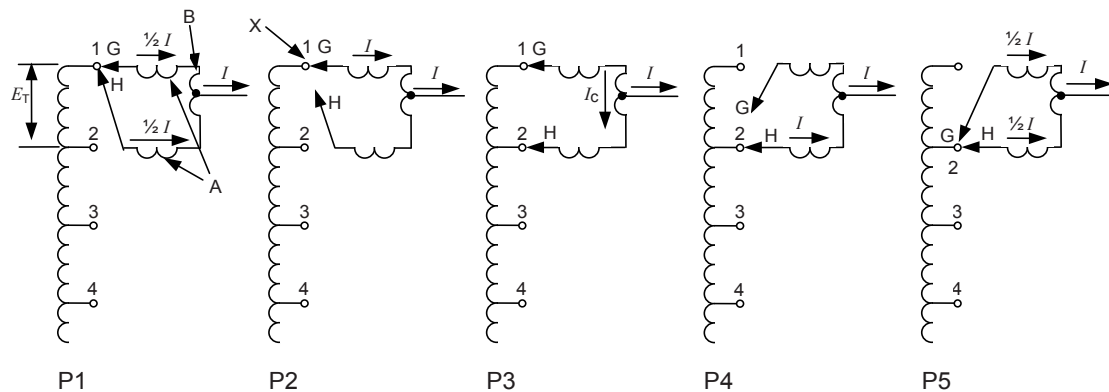

IEC 1795/14

Key

A is the reactor (2 in total)

B is the equalizing winding

X is the selector switch (2 in total)

Figure B.3 – Operating sequence of reactor type tap-changers with selector switch and equalizer windings

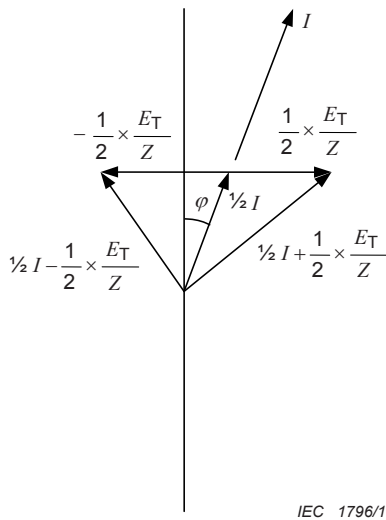

Figure B.4a – Current

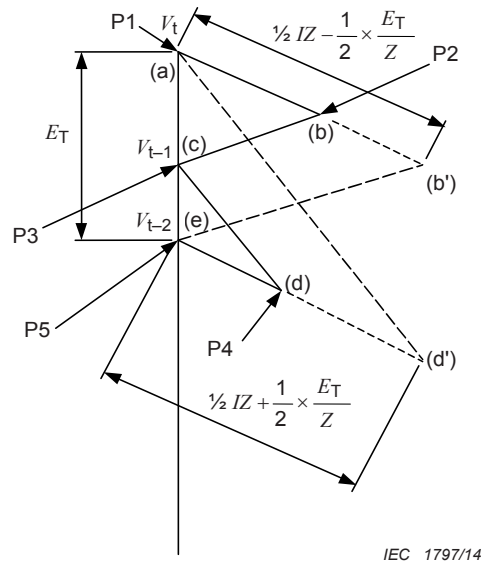

Figure B.4b – Voltage

NOTE 1 System voltage progression during transition steps for two tap position change operations are shown in brackets (a) to (e) in Figure B.4b. Points (a), (c) and (e) represent quiescent operation. Points (b) and (d) represent momentary operations due to reactance drop.

NOTE 2 Vectors (a-b') and (e-d') represent reactor voltage due to transformer action.

NOTE 3 Shown for $|E_T/2Z| \cong 0,5 |I|$.

Figure B.4 – Current and voltage vectors for reactor type tap-changers with selector switch and equalizer windings

Table B.3 – Duty of switching contacts for reactor type tap-changers with diverter switch and tap selector – Switching direction from P1 to P7

Operating sequence (NOTE 1)	Contact operation	Contact	Switching current	Recovery voltage
P1 On tap 1	N/A	G	-	-
		H	-	-
P2 Transition to bridging (diverter switch opens)	H breaks	G	-	-
		H	$\frac{1}{2}I$ (NOTE 2)	$\frac{1}{2}IZ$
P3 Transition to bridging (selector moves to bridging)	Selector moves to bridge taps 1 and 2	G	-	-
		H	-	-
P4 Bridging taps 1 and 2	H makes	G	-	-
		H	-	-
P5 Transition to on-tap 2 (diverter switch opens)	G breaks	G	$\frac{1}{2}I + E_T/Z$ (NOTE 3)	$E_T + \frac{1}{2}IZ$
		H	-	-
P6 Transition to on-tap 2	Selector moves to tap 2	G	-	-
		H	-	-
P7 On tap 2	G makes	G	-	-
		H	-	-

NOTE 1 P1, P4 and P7 are operating positions.

NOTE 2 I is the load current.

NOTE 3 E_T/Z is equal to I_C , the circulating current, Z is the impedance of the preventive auto-transformer and E_T is the tap voltage.

NOTE 4 When the transition to on-tap is in the reverse direction, that is, from P7 to P1, the switching current at the G contact is $\frac{1}{2}I$ and the corresponding recovery voltage is $\frac{1}{2}IZ$ (P6). The switched current at the H contact is $\frac{1}{2}I - E_T/Z$ and the corresponding recovery voltage is $E_T - \frac{1}{2}IZ$ (P3).

NOTE 5 See Figure B.5 for the operating sequence diagrams and Figure B.6 for the vector diagrams.

NOTE 6 All additions shown in the table are vector additions.

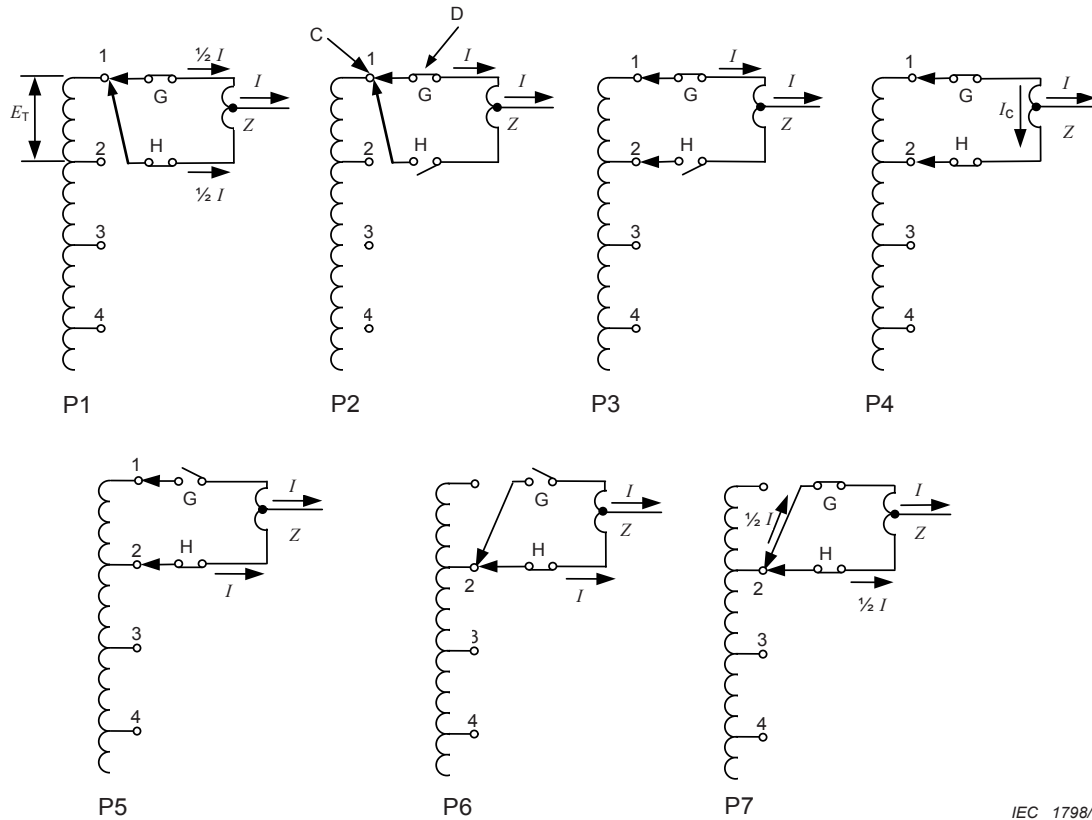

IEC 1798/14

Key

C is the tap selector (2 in total)

D is the diverter switch (2 in total)

G and H are the diverter switches

Position P1 shows operation on tap 1

Position P4 shows taps 1 and 2 being bridged

Position P7 shows operation on tap 2

Figure B.5 – Operating sequence of a reactor type tap-changer with diverter switch and tap selector

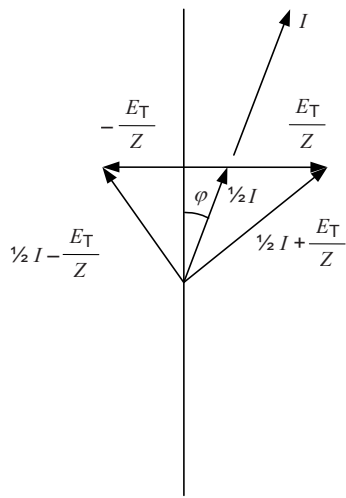

Figure B.6a – Current

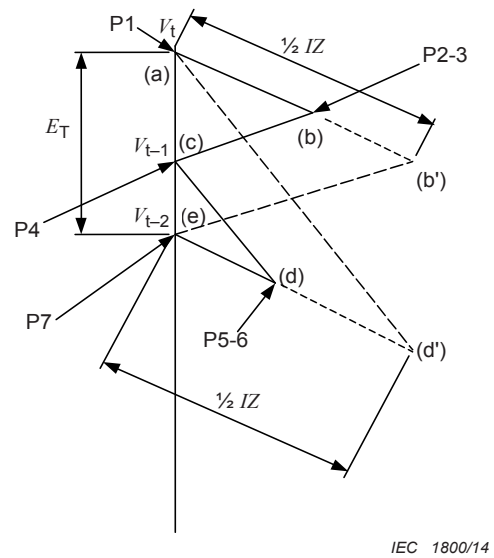

Figure B.6b – Voltage

NOTE 1 System voltage progression during transition steps for two tap position change operations are shown in brackets (a) to (e) in Figure B.6b. Points (a), (c) and (e) represent quiescent operation. Points (b) and (d) represent momentary operations due to reactance drop.

NOTE 2 Vectors (a-b') and (e-d') represent reactor voltage due to transformer action.

NOTE 3 Shown for $|E_T/Z| \cong 0,5 |I|$.

Figure B.6 – Current and voltage vectors for reactor type tap-changers with diverter switch and tap selector

Table B.4 – Duty of switching contacts for reactor type tap-changers with vacuum interrupter and tap selector – Switching direction from P1 to P11

Operating sequence (NOTE 1)	Contact	Contact operation	Switching current	Recovery voltage
P1 On tap 1	G	Closed	-	-
	V	Closed	-	-
	H	Closed	-	-
P2 Transition to bridging (by-pass switch opens)	G	Closed	-	-
	V	Closed	-	-
	H	Open	-	-
P3 Transition to bridging (vacuum switch opens)	G	Closed	-	-
	V	Breaks	$\frac{1}{2}I$ (NOTE 2)	$\frac{1}{2}IZ$
	H	Open	-	-
P4 Transition to bridging (selector moves to tap 2)	G	Closed	-	-
	V	Open	-	-
	H	Open	-	-
P5 Transition to bridging (vacuum switch closes)	G	Closed	-	-
	V	Makes	-	-
	H	Open	-	-
P6 Bridging taps 1 and 2 (by-pass switch closes)	G	Closed	-	-
	V	Closed	-	-
	H	Closed	-	-
P7 Transition to on-tap 2 (by-pass switch opens)	G	Open	-	-
	V	Closed	-	-
	H	Closed	-	-
P8 Transition to on-tap 2 (vacuum switch opens)	G	Open	-	-
	V	Breaks	$\frac{1}{2}I + E_T/Z$ (NOTE 3)	$E_T + \frac{1}{2}IZ$
	H	Closed	-	-
P9 Transition to on-tap 2 (selector moves to tap 2)	G	Open	-	-
	V	Open	-	-
	H	Closed	-	-
P10 Transition to on-tap 2 (vacuum switch closes)	G	Open	-	-
	V	Makes	-	-
	H	Closed	-	-
P11 On tap 2	G	Closed	-	-
	V	Closed	-	-
	H	Closed	-	-

NOTE 1 P1, P6 and P11 are operating positions.

NOTE 2 I is the load current.

NOTE 3 E_T/Z is equal to I_C , the circulating current, Z is the impedance of the preventive autotransformer and E_T is the tap voltage.

NOTE 4 When the transition to on-tap is in the reverse direction, that is, from P11 to P1, the switching current at the V contact is $\frac{1}{2}I$ and the corresponding recovery voltage is $\frac{1}{2}IZ$ (P9). The switched current at V contact is $E_T/Z - \frac{1}{2}I$ and the corresponding recovery voltage is $E_T - \frac{1}{2}IZ$ (P4).

NOTE 5 See Figure B.7 for the operating sequence diagrams and Figure B.8 for the vector diagrams.

NOTE 6 All additions shown in the table are vector additions.

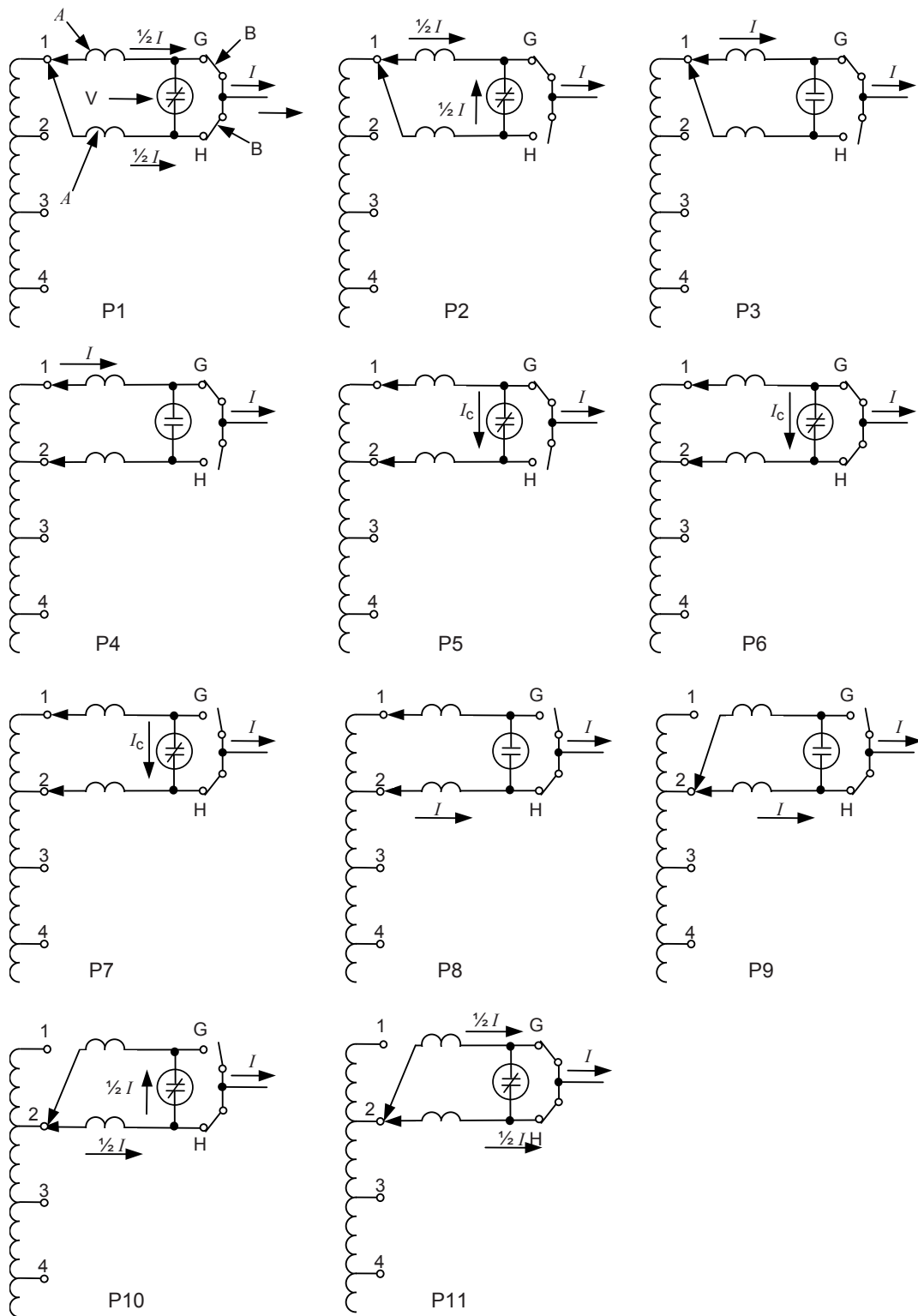

Key

A is the reactor (2 in total)

B is the by-pass switch (2 in total)

V is the vacuum interrupter

Figure B.7 – Operating sequence of a reactor type tap-changer with vacuum interrupter and tap selector

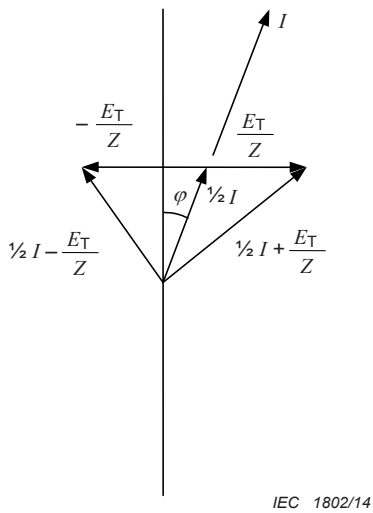

Figure B.8a – Current

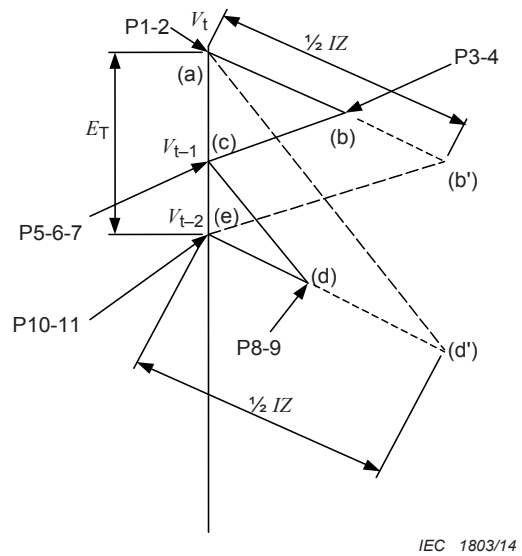

Figure B.8b – Voltage

NOTE 1 System voltage progression during transition steps for two tap position change operations are shown in brackets (a) to (e) in Figure B.8b. Points (a), (c) and (e) represent quiescent operation. Points (b) and (d) represent momentary operations due to reactance drop.

NOTE 2 Vectors (a-b') and (e-d') represent reactor voltage due to transformer action.

NOTE 3 Shown for $|E_T/Z| \cong 0,5 |I|$.

Figure B.8 – Current and voltage vectors for reactor type tap-changers with vacuum interrupter and tap selector

Annex C (normative)

Method for determining the equivalent temperature of the transition resistor using power pulse current

Set up the resistor in an on-load tap-changer or in a thermally equivalent situation, suitable arrangements being made to measure the temperature of the resistance material. The thermocouples or thermometers for measuring the temperature of the cooling medium should be positioned not less than 25 mm below the lowest point of the resistance material.

Measure and record the temperature of the resistance material and of the cooling medium at the start of the test.

The test shall be performed with current I_p , the r.m.s. value of which is obtained from

$$I_p = \frac{1}{\sqrt{k}} \times \sqrt{\frac{\sum_{i=1}^n (I_i^2 \times t_i)}{\sum_{i=1}^n t_i}}$$

where

I_i is the current value loading the transition resistor throughout different steps of the switching sequence. For the calculation of the particular currents, the through-current has to be set to 1,5 times the maximum through-current (see 5.2.5);

t_i is the time during which the particular currents I_i are flowing. These values have to be taken as a mean value from the service duty test according to 5.2.3.2;

k is the coefficient chosen to suit the testing requirements of the resistor; the value adopted should be below 5. Values between 5 and 10 shall only be used if the heating phenomenon remains to be adiabatic.

It has to be considered that the current I_i and the time t_i are depending on the operating cycle of the diverter/selecter switch.

The resistor shall be subjected to the above current for a number of times corresponding to one-half of one cycle of operations. The duration of the current application shall be determined from

$$t_p = k \sum_{i=1}^n t_i$$

The rest period during which current does not flow through the resistor shall be equal to the minimum time interval that can occur between two consecutive operations of the tap-changer.

To determine the peak temperature, extrapolation of recorded values may be necessary.

Annex D (informative)

Simulated a.c. circuits for service duty and breaking capacity tests

D.1 General

Two proven simulated test circuits are shown in Figures D.1 and D.2. Figure D.1 being a transformer method and Figure D.2 a resistance method, see 5.2.3.5. These figures are given for information only and the use of different circuits is not excluded.

D.2 Transformer method

In order to meet the requirements in 5.2.3.2 and 5.2.3.3 and to take into account the reactances of the circuit and supply, the current and voltage values occurring on the four contacts (see Figure D.1) should be controlled and when necessary suitably adjusted, for example, by means of variations of the U_{ED} , X_a and R values and/or of the mutual phase of the voltage vectors.

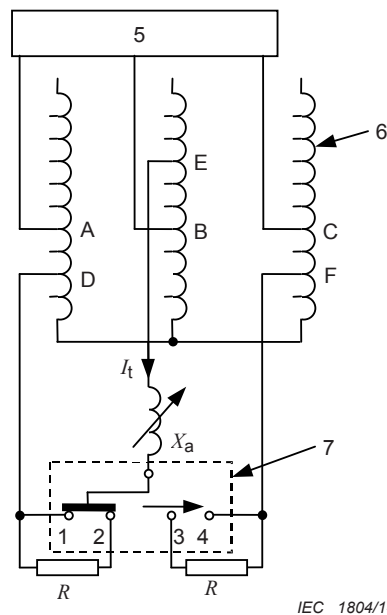

Key

1 and 4	are the main contacts	R	is the transition resistor
2 and 3	are the transition contacts	X_a	is an adjustable reactor
5	is the supply from a generator or network	$U_{AR} = U_{RC} = U_{CA}$	is the three-phase supply voltage
6	is the auto-transformer, or transformer, with step adjustable voltages	U_{DF}	is the step voltage relevant to I_t
7	is the diverter switch	I_t	is the test current to be adjusted by means of U_{ED} and X_a

Figure D.1 – Simulated test circuit – Transformer method

D.3 Resistance method

In order to meet the requirements in 5.2.3.2 and 5.2.3.3 and to take into account the impedance of the circuit and supply, the current and voltage values occurring on the four contacts (see Figure D.2) should be controlled and when necessary, adjusted, by means of small variations of the R_1 ohmic value.

The calculated current and voltage values occurring in the whole tap-change operation on the four contacts should be used to calculate the power divider (see Figure D.2).

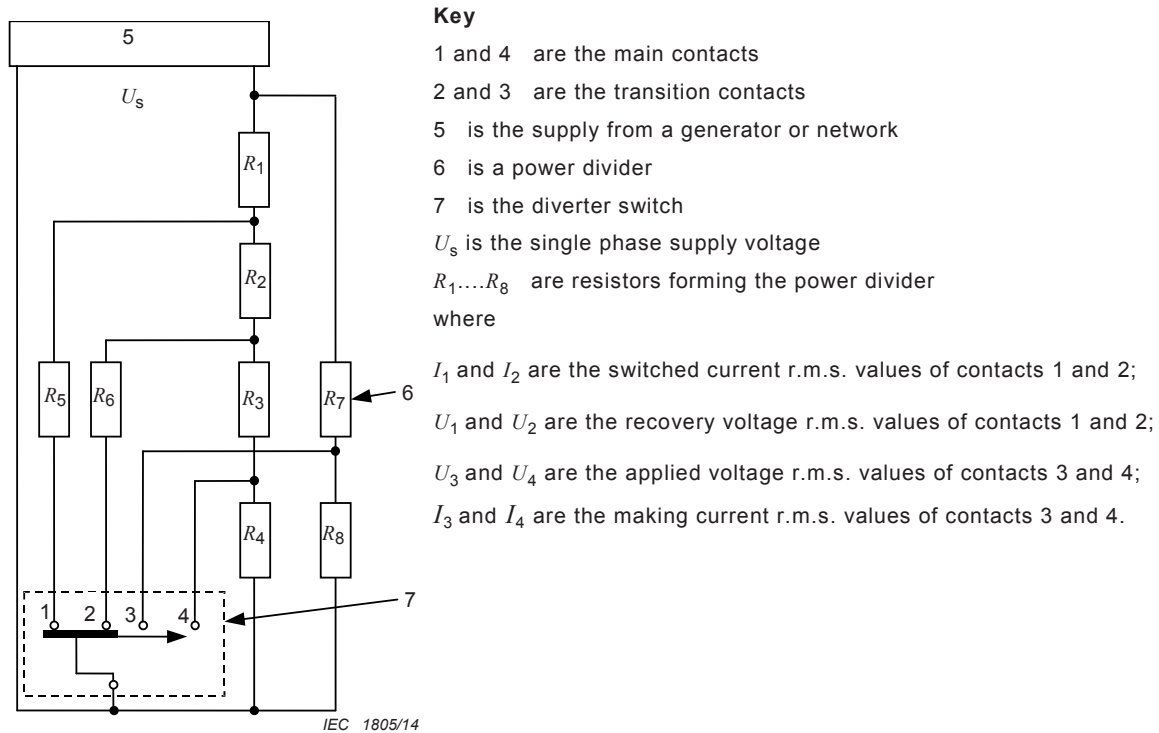

Figure D.2 – Simulated test circuit – Resistance method

In the case under consideration (four-contact diverter switch with operating cycle number 1 according to Table A.1), the equation for the most onerous conditions is given in the following equations:

$$R_1 = \frac{U_s(U_s - U_1)}{I_4(U_s - U_4) + U_2 I_2} \quad (\text{D.1})$$

$$R_2 = \frac{U_s(U_1 - U_2)}{I_4(U_s - U_4) + U_2 I_2} + \frac{U_s}{I_4(U_s - U_4)} \times \frac{U_2 I_2 (U_s - U_2)}{I_4(U_s - U_4) + U_2 I_2} \quad (\text{D.2})$$

$$R_3 = \frac{U_s}{I_4} \times \frac{U_2 - U_4}{U_s - U_4} \quad (\text{D.3})$$

$$R_4 = \frac{U_s}{I_4} \times \frac{U_4}{U_s - U_4} \quad (\text{D.4})$$

$$R_5 = \frac{U_1}{I_1} - \frac{U_1(U_s - U_1)}{I_4(U_s - U_4) + U_2 I_2} \quad (\text{D.5})$$

$$R_6 = \frac{U_2}{I_2} - \frac{U_2(U_s - U_2)}{I_4(U_s - U_4)} \quad (\text{D.6})$$

$$R_7 = \frac{U_s}{I_3} \quad (\text{D.7})$$

$$R_8 = \frac{U_3}{I_3} \times \frac{U_s}{U_s - U_3} \quad (\text{D.8})$$

Annex E (informative)

Example of a synthetic test circuit for service duty test of vacuum type tap-changers

E.1 Definitions with relevance to the synthetic test circuit

E.1.1 Synthetic test circuit

test circuit with a power supply other than an a.c. generator or a transformer

E.1.2 Simulated a.c. test circuit

test circuit according to Annex D

E.1.3 Pre-arc

arc that appears between closing contacts when the distance has become so small that a flashover occurs between the contacts

E.1.4 Making voltage

voltage applied across closing contacts

E.2 Example for the test setup of a synthetic test circuit

Figure E.1 shows an example of an appropriate synthetic test circuit.

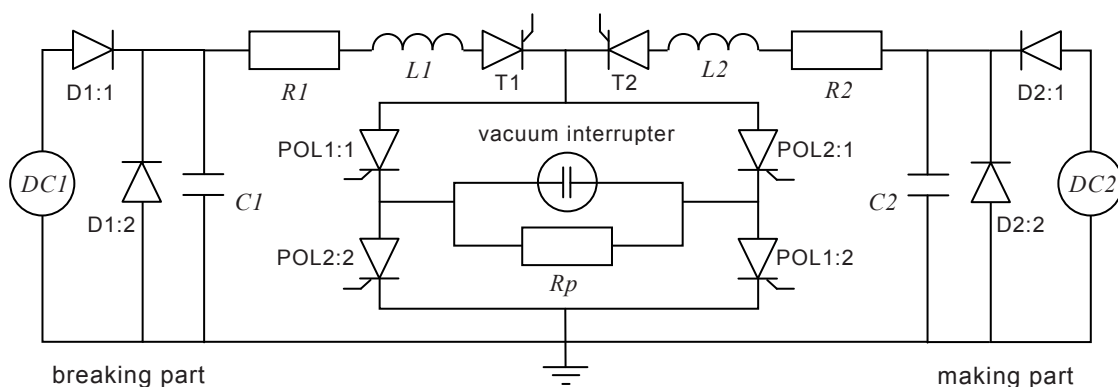

IEC 1806/14

Figure E.1 – Synthetic test circuit for service duty test of vacuum type tap-changers

The principle is to use d.c. currents and d.c. voltages from charged capacitors instead of a.c. current and voltage. The capacitors are charged for each operation and the discharge is controlled by inductances and resistors.

In the breaking part, *DC1* is a d.c. generator charging capacitor *C1*. Thyristor *T2* blocks or starts the discharge of *C1*. Inductance *L2* and resistor *R2* are tuned to give a substantially sine-wave shaped discharging current with a period time very close to that for 50 Hz or 60 Hz.

In the making part, $DC2$ is a d.c. generator charging capacitor $C2$. Thyristor T1 blocks or starts the discharge of $C2$. Inductance $L1$ and resistor $R1$ are tuned to give current derivative as close to that of a real transformer as possible.

The thyristors POL1:1, 1:2, 2:1 and 2:2 are for changing polarity on the test object. The resistor R_p keeps the making part thyristors conducting until a re-strike or the closing of the vacuum interrupter occurs.

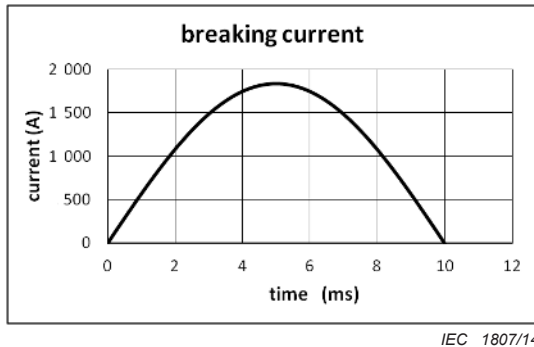

Figure E.2a – Breaking current

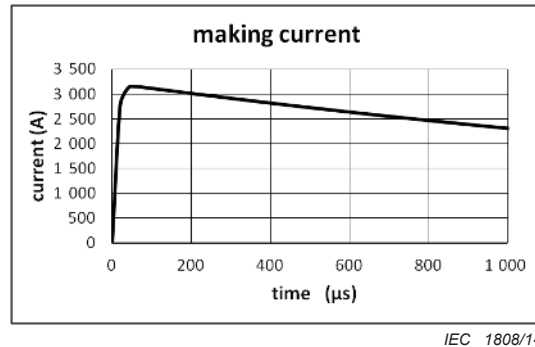

Figure E.2b – Making current

Figure E.2 – Currents of the synthetic test circuit

The breaking current is tuned to look as shown in Figure E.2a. In this case, it is approximately 1 300 A r.m.s at 50 Hz.

The making current is tuned to look as shown in Figure E.2b. In this example, it rises to 3 200 A in about 0,05 ms, giving a current derivative of about 70 kA/ms and a time constant of 10 μ s. This example simulates closing conditions for a vacuum type tap-changer with a current rating of 1 300 A (operating cycles, where the closing voltage is $E + RI$ and the closing current is $E/R + I$, see Table A.3.).

E.3 Example for the breaking/making condition during a switching operation

In the example below (Figure E.3), the recovery voltage and the making voltage are the same. These two voltages could be different and in such case two different circuits generating different recovery voltage and making voltage shall be applied.

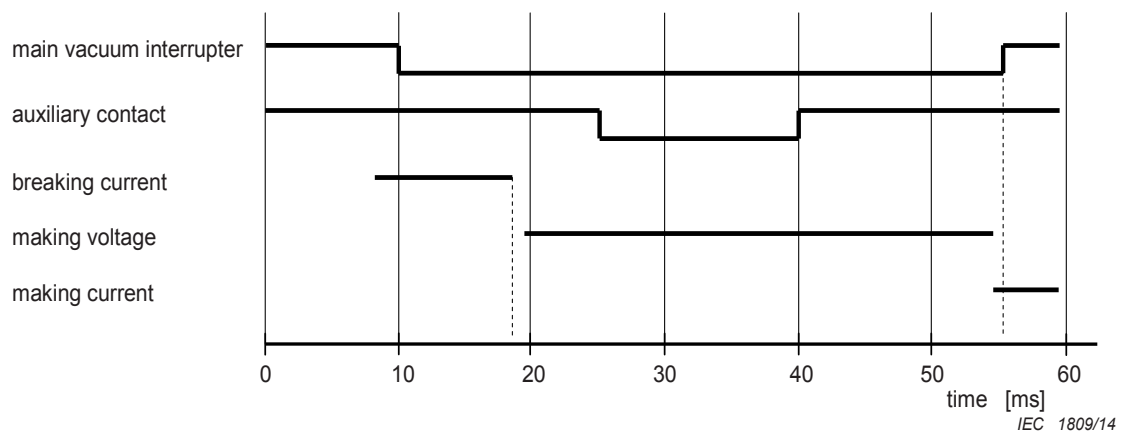

Figure E.3 – Example of the synthetic test for a switching operation with equal voltages for breaking and making duty

At time approximates 9 ms, the breaking current is switched on. At time 10 ms, the main vacuum interrupter opens. An arc of 9 ms (can be changed between 0 ms and 10 ms by varying the opening time of the vacuum interrupter) will be achieved. Just before 20 ms, the arc is extinguished and by measuring the arc voltage, a distinct and clear indication is given when the arc is extinguished.

Within less than or equal to 0,1 ms after extinguishing the arc, the recovery voltage is switched on. In case of no re-ignition the voltage will still be on before closing the contacts and acts as the making voltage. When the vacuum interrupter has started to close and the distance between the contacts has become small (approximately parts of millimetres), a pre-arc will occur and the making circuit will discharge generating the correct closing conditions.

Bibliography

IEC 60076-1:2011, *Power transformers – Part 1: General*

IEC 60076-11, *Power transformers – Part 11: Dry-type transformers*

IEC 60076-12, *Power transformers – Part 12: Loading guide for dry-type power transformers*

IEC 60076-15, *Power transformers – Part 15: Gas-filled power transformers*

IEC 60376, *Specification of technical grade sulfur hexafluoride (SF₆) for use in electrical equipment*

IEC 60599, *Mineral oil-impregnated electrical equipment in service – Guide to the interpretation of dissolved and free gases analysis*

British Standards Institution (BSI)

BSI is the national body responsible for preparing British Standards and other standards-related publications, information and services.

BSI is incorporated by Royal Charter. British Standards and other standardization products are published by BSI Standards Limited.

About us

We bring together business, industry, government, consumers, innovators and others to shape their combined experience and expertise into standards-based solutions.

The knowledge embodied in our standards has been carefully assembled in a dependable format and refined through our open consultation process. Organizations of all sizes and across all sectors choose standards to help them achieve their goals.

Information on standards

We can provide you with the knowledge that your organization needs to succeed. Find out more about British Standards by visiting our website at bsigroup.com/standards or contacting our Customer Services team or Knowledge Centre.

Buying standards

You can buy and download PDF versions of BSI publications, including British and adopted European and international standards, through our website at bsigroup.com/shop, where hard copies can also be purchased.

If you need international and foreign standards from other Standards Development Organizations, hard copies can be ordered from our Customer Services team.

Subscriptions

Our range of subscription services are designed to make using standards easier for you. For further information on our subscription products go to bsigroup.com/subscriptions.

With **British Standards Online (BSOL)** you'll have instant access to over 55,000 British and adopted European and international standards from your desktop. It's available 24/7 and is refreshed daily so you'll always be up to date.

You can keep in touch with standards developments and receive substantial discounts on the purchase price of standards, both in single copy and subscription format, by becoming a **BSI Subscribing Member**.

PLUS is an updating service exclusive to BSI Subscribing Members. You will automatically receive the latest hard copy of your standards when they're revised or replaced.

To find out more about becoming a BSI Subscribing Member and the benefits of membership, please visit bsigroup.com/shop.

With a **Multi-User Network Licence (MUNL)** you are able to host standards publications on your intranet. Licences can cover as few or as many users as you wish. With updates supplied as soon as they're available, you can be sure your documentation is current. For further information, email bsmusales@bsigroup.com.

BSI Group Headquarters

389 Chiswick High Road London W4 4AL UK

Revisions

Our British Standards and other publications are updated by amendment or revision.

We continually improve the quality of our products and services to benefit your business. If you find an inaccuracy or ambiguity within a British Standard or other BSI publication please inform the Knowledge Centre.

Copyright

All the data, software and documentation set out in all British Standards and other BSI publications are the property of and copyrighted by BSI, or some person or entity that owns copyright in the information used (such as the international standardization bodies) and has formally licensed such information to BSI for commercial publication and use. Except as permitted under the Copyright, Designs and Patents Act 1988 no extract may be reproduced, stored in a retrieval system or transmitted in any form or by any means – electronic, photocopying, recording or otherwise – without prior written permission from BSI. Details and advice can be obtained from the Copyright & Licensing Department.

Useful Contacts:

Customer Services

Tel: +44 845 086 9001

Email (orders): orders@bsigroup.com

Email (enquiries): cservices@bsigroup.com

Subscriptions

Tel: +44 845 086 9001

Email: subscriptions@bsigroup.com

Knowledge Centre

Tel: +44 20 8996 7004

Email: knowledgecentre@bsigroup.com

Copyright & Licensing

Tel: +44 20 8996 7070

Email: copyright@bsigroup.com



...making excellence a habit.™