

BS EN 60099-4:2014



BSI Standards Publication

Surge arresters

Part 4: Metal-oxide surge arresters
without gaps for a.c. systems

bsi.

...making excellence a habit.™

National foreword

This British Standard is the UK implementation of EN 60099-4:2014. It is identical to IEC 60099-4:2014. It supersedes BS EN 60099-4:2004+A2:2009 which is withdrawn.

The UK participation in its preparation was entrusted to Technical Committee PEL/37, Surge Arresters - High Voltage.

A list of organizations represented on this committee can be obtained on request to its secretary.

This publication does not purport to include all the necessary provisions of a contract. Users are responsible for its correct application.

© The British Standards Institution 2014.
Published by BSI Standards Limited 2014

ISBN 978 0 580 74612 3
ICS 29.120.50; 29.240.10

Compliance with a British Standard cannot confer immunity from legal obligations.

This British Standard was published under the authority of the Standards Policy and Strategy Committee on 30 September 2014.

Amendments/corrigenda issued since publication

Date	Text affected
------	---------------

EUROPEAN STANDARD
NORME EUROPÉENNE
EUROPÄISCHE NORM

EN 60099-4

September 2014

ICS 29.240.10; 29.120.50

Supersedes EN 60099-4:2004

English Version

**Surge arresters - Part 4: Metal-oxide surge arresters without
gaps for a.c. systems
(IEC 60099-4:2014)**

Parafoudres - Partie 4: Parafoudres à oxyde métallique
sans éclateur pour réseaux à courant alternatif
(CEI 60099-4:2014)

Überspannungsableiter - Teil 4: Metalloxidableiter ohne
Funkenstrecken für Wechselspannungsnetze
(IEC 60099-4:2014)

This European Standard was approved by CENELEC on 2014-08-04. CENELEC members are bound to comply with the CEN/CENELEC Internal Regulations which stipulate the conditions for giving this European Standard the status of a national standard without any alteration.

Up-to-date lists and bibliographical references concerning such national standards may be obtained on application to the CEN-CENELEC Management Centre or to any CENELEC member.

This European Standard exists in three official versions (English, French, German). A version in any other language made by translation under the responsibility of a CENELEC member into its own language and notified to the CEN-CENELEC Management Centre has the same status as the official versions.

CENELEC members are the national electrotechnical committees of Austria, Belgium, Bulgaria, Croatia, Cyprus, the Czech Republic, Denmark, Estonia, Finland, Former Yugoslav Republic of Macedonia, France, Germany, Greece, Hungary, Iceland, Ireland, Italy, Latvia, Lithuania, Luxembourg, Malta, the Netherlands, Norway, Poland, Portugal, Romania, Slovakia, Slovenia, Spain, Sweden, Switzerland, Turkey and the United Kingdom.



European Committee for Electrotechnical Standardization
Comité Européen de Normalisation Electrotechnique
Europäisches Komitee für Elektrotechnische Normung

CEN-CENELEC Management Centre: Avenue Marnix 17, B-1000 Brussels

Foreword

The text of document 37/416/FDIS, future edition 3 of IEC 60099-4, prepared by IEC/TC 37 "Surge arresters" was submitted to the IEC-CENELEC parallel vote and approved by CENELEC as EN 60099-4:2014.

The following dates are fixed:

- latest date by which the document has to be implemented at national level by publication of an identical national standard or by endorsement (dop) 2015-05-04
- latest date by which the national standards conflicting with the document have to be withdrawn (dow) 2017-08-04

This document supersedes EN 60099-4:2004.

Attention is drawn to the possibility that some of the elements of this document may be the subject of patent rights. CENELEC [and/or CEN] shall not be held responsible for identifying any or all such patent rights.

Endorsement notice

The text of the International Standard IEC 60099-4:2014 was approved by CENELEC as a European Standard without any modification.

In the official version, for Bibliography, the following notes have to be added for the standards indicated:

IEC 60068-2-17	NOTE	Harmonized as EN 60068-2-17.
IEC 60099-1	NOTE	Harmonized as EN 60099-1.
IEC 60099-5:2013	NOTE	Harmonized as EN 60099-5:2013 (not modified).
IEC 60721-3-2	NOTE	Harmonized as EN 60721-3-2.
IEC 62271-202:2006	NOTE	Harmonized as EN 62271-202:2007 (not modified).
ISO 3274	NOTE	Harmonized as EN ISO 3274.

Annex ZA (normative)

Normative references to international publications with their corresponding European publications

The following documents, in whole or in part, are normatively referenced in this document and are indispensable for its application. For dated references, only the edition cited applies. For undated references, the latest edition of the referenced document (including any amendments) applies.

NOTE 1 When an International Publication has been modified by common modifications, indicated by (mod), the relevant EN/HD applies.

NOTE 2 Up-to-date information on the latest versions of the European Standards listed in this annex is available here: www.cenelec.eu.

<u>Publication</u>	<u>Year</u>	<u>Title</u>	<u>EN/HD</u>	<u>Year</u>
IEC 60060-1	-	High-voltage test techniques - Part 1: General definitions and test requirements	EN 60060-1	-
IEC 60060-2	-	High-voltage test techniques - Part 2: Measuring systems	EN 60060-2	-
IEC 60068-2-11	1981	Environmental testing - Part 2: Tests - Test Ka: Salt mist	EN 60068-2-11	1999
IEC 60068-2-14	-	Environmental testing - Part 2-14: Tests - Test N: Change of temperature	EN 60068-2-14	-
IEC 60071-1	-	Insulation co-ordination - Part 1: Definitions, principles and rules	EN 60071-1	-
IEC 60071-2	1996	Insulation co-ordination - Part 2: Application guide	EN 60071-2	1997
IEC 60270	-	High-voltage test techniques - Partial discharge measurements	EN 60270	-
IEC 60507	2013	Artificial pollution tests on high-voltage ceramic and glass insulators to be used on a.c. systems	EN 60507	2014
IEC 62217	-	Polymeric HV insulators for indoor and outdoor use - General definitions, test methods and acceptance criteria	EN 62217	-
IEC 62271-1	2007	High-voltage switchgear and controlgear - Part 1: Common specifications	EN 62271-1	2008
IEC 62271-200	2011	High-voltage switchgear and controlgear - Part 200: AC metal-enclosed switchgear and controlgear for rated voltages above 1 kV and up to and including 52 kV	EN 62271-200	2012
IEC 62271-203	2011	High-voltage switchgear and controlgear - Part 203: Gas-insulated metal-enclosed switchgear for rated voltages above 52 kV	EN 62271-203	2012

<u>Publication</u>	<u>Year</u>	<u>Title</u>	<u>EN/HD</u>	<u>Year</u>
IEC/TS 60815-1	2008	Selection and dimensioning of high-voltage insulators intended for use in polluted conditions - Part 1: Definitions, information and general principles	-	-
IEC/TS 60815-2	2008	Selection and dimensioning of high-voltage insulators intended for use in polluted conditions - Part 2: Ceramic and glass insulators for a.c. systems	-	-
ISO 4287	-	Geometrical Product Specifications (GPS) - Surface texture: Profile method - Terms, definitions and surface texture parameters	EN ISO 4287	-
ISO 4892-1	-	Plastics - Methods of exposure to laboratory light sources - Part 1: General guidance	EN ISO 4892-1	-
ISO 4892-2	-	Plastics - Methods of exposure to laboratory light sources - Part 2: Xenon-arc lamps	EN ISO 4892-2	-
ISO 4892-3	-	Plastics - Methods of exposure to laboratory light sources - Part 3: Fluorescent UV lamps	EN ISO 4892-3	-
CISPR/TR 18-2	-	Radio interference characteristics of overhead power lines and high-voltage equipment - Part 2: Methods of measurement and procedure for determining limits	-	-

CONTENTS

INTRODUCTION.....	14
1 Scope.....	15
2 Normative references	15
3 Terms and definitions	16
4 Identification and classification	26
4.1 Arrester identification	26
4.2 Arrester classification	26
5 Standard ratings and service conditions	27
5.1 Standard rated voltages	27
5.2 Standard rated frequencies	27
5.3 Standard nominal discharge currents	27
5.4 Service conditions.....	27
5.4.1 Normal service conditions.....	27
5.4.2 Abnormal service conditions	27
6 Requirements	28
6.1 Insulation withstand	28
6.2 Reference voltage.....	28
6.3 Residual voltages	28
6.4 Internal partial discharges.....	29
6.5 Seal leak rate.....	29
6.6 Current distribution in a multi-column arrester.....	29
6.7 Thermal stability	29
6.8 Long term stability under continuous operating voltage	29
6.9 Heat dissipation behaviour of test sample	29
6.10 Repetitive charge transfer withstand	29
6.11 Operating duty	29
6.12 Power-frequency voltage versus time characteristics of an arrester	29
6.13 Short-circuit performance.....	30
6.14 Disconnecter.....	30
6.14.1 Disconnecter withstand.....	30
6.14.2 Disconnecter operation.....	30
6.15 Requirements on internal grading components.....	30
6.16 Mechanical loads	31
6.16.1 General	31
6.16.2 Bending moment.....	31
6.16.3 Resistance against environmental stresses	31
6.16.4 Insulating base and mounting bracket.....	31
6.16.5 Mean value of breaking load (MBL).....	31
6.16.6 Electromagnetic compatibility	31
6.17 End of life	31
6.18 Lightning impulse discharge capability	31
7 General testing procedure	32
7.1 Measuring equipment and accuracy.....	32
7.2 Reference voltage measurements	32

7.3	Test samples	32
7.3.1	General	32
7.3.2	Arrester section requirements	33
8	Type tests (design tests)	34
8.1	General.....	34
8.2	Insulation withstand tests	35
8.2.1	General	35
8.2.2	Tests on individual unit housings	36
8.2.3	Tests on complete arrester assemblies	36
8.2.4	Ambient air conditions during tests	36
8.2.5	Wet test procedure	36
8.2.6	Lightning impulse voltage test.....	37
8.2.7	Switching impulse voltage test.....	37
8.2.8	Power-frequency voltage test.....	37
8.3	Residual voltage tests.....	38
8.3.1	General	38
8.3.2	Steep current impulse residual voltage test.....	38
8.3.3	Lightning impulse residual voltage test	39
8.3.4	Switching impulse residual voltage test.....	39
8.4	Test to verify long term stability under continuous operating voltage	39
8.4.1	General	39
8.4.2	MO resistor elements stressed below U_{ref}	40
8.4.3	Test procedure for MO resistor elements stressed at or above U_{ref}	41
8.5	Test to verify the repetitive charge transfer rating, Q_{rs}	44
8.5.1	General	44
8.5.2	Test procedure	45
8.5.3	Test evaluation	46
8.5.4	Rated values of repetitive charge transfer rating, Q_{rs}	46
8.6	Heat dissipation behaviour of test sample	47
8.6.1	General	47
8.6.2	Arrester section requirements	47
8.6.3	Procedure to verify thermal equivalency between complete arrester and arrester section	47
8.7	Operating duty test	47
8.7.1	General	47
8.7.2	Test procedure	48
8.7.3	Rated thermal energy and charge values, W_{th} and Q_{th}	51
8.8	Power-frequency voltage-versus-time test.....	52
8.8.1	General	52
8.8.2	Test samples	53
8.8.3	Initial measurements	54
8.8.4	Test procedure	54
8.8.5	Test evaluation	55
8.9	Tests of arrester disconnecter.....	55
8.9.1	General	55
8.9.2	Operating withstand test.....	55
8.9.3	Disconnecter operation	56
8.9.4	Mechanical tests.....	57
8.9.5	Temperature cycling and seal pumping test	58

8.10	Short-circuit tests	58
8.10.1	General	58
8.10.2	Preparation of the test samples	59
8.10.3	Mounting of the test sample	63
8.10.4	High-current short-circuit tests	64
8.10.5	Low-current short-circuit test	67
8.10.6	Evaluation of test results	67
8.11	Test of the bending moment	67
8.11.1	General	67
8.11.2	Overview	67
8.11.3	Sample preparation	68
8.11.4	Test procedure	68
8.11.5	Test evaluation	68
8.11.6	Test on insulating base and mounting bracket	69
8.12	Environmental tests	69
8.12.1	General	69
8.12.2	Sample preparation	69
8.12.3	Test procedure	69
8.12.4	Test evaluation	70
8.13	Seal leak rate test	70
8.13.1	General	70
8.13.2	Sample preparation	70
8.13.3	Test procedure	70
8.13.4	Test evaluation	70
8.14	Radio interference voltage (RIV) test	70
8.15	Test to verify the dielectric withstand of internal components	72
8.15.1	General	72
8.15.2	Test procedure	72
8.15.3	Test evaluation	72
8.16	Test of internal grading components	72
8.16.1	Test to verify long term stability under continuous operating voltage	72
8.16.2	Thermal cyclic test	73
9	Routine tests and acceptance tests	74
9.1	Routine tests	74
9.2	Acceptance tests	75
9.2.1	Standard acceptance tests	75
9.2.2	Special thermal stability test	76
10	Test requirements on polymer-housed surge arresters	76
10.1	Scope	76
10.2	Normative references	76
10.3	Terms and definitions	76
10.4	Identification and classification	76
10.5	Standard ratings and service conditions	76
10.6	Requirements	76
10.7	General testing procedure	77
10.8	Type tests (design tests)	77
10.8.1	General	77
10.8.2	Insulation withstand tests	77

10.8.3	Residual voltage tests	77
10.8.4	Test to verify long term stability under continuous operating voltage	78
10.8.5	Test to verify the repetitive charge transfer rating, Q_{rs}	78
10.8.6	Heat dissipation behaviour of test sample	78
10.8.7	Operating duty tests	78
10.8.8	Power frequency voltage-versus-time test.....	78
10.8.9	Tests of arrester disconnector	79
10.8.10	Short-circuit tests	79
10.8.11	Test of the bending moment	85
10.8.12	Environmental tests	92
10.8.13	Seal leak rate test.....	92
10.8.14	Radio interference voltage (RIV) test	92
10.8.15	Test to verify the dielectric withstand of internal components	92
10.8.16	Test of internal grading components	92
10.8.17	Weather ageing test.....	92
10.9	Routine tests.....	94
11	Test requirements on gas-insulated metal enclosed arresters (GIS-arresters)	94
11.1	Scope	94
11.2	Normative references.....	94
11.3	Terms and definitions.....	94
11.4	Identification and classification	94
11.5	Standard ratings and service conditions	95
11.6	Requirements	95
11.6.1	Withstand voltages	95
11.7	General testing procedures	98
11.8	Type tests (design tests).....	98
11.8.1	General	98
11.8.2	Insulation withstand tests	98
11.8.3	Residual voltage tests	101
11.8.4	Test to verify long term stability under continuous operating voltage.....	101
11.8.5	Test to verify the repetitive charge transfer rating, Q_{rs}	101
11.8.6	Heat dissipation behaviour of test sample	101
11.8.7	Operating duty tests	101
11.8.8	Power frequency voltage-versus-time test.....	101
11.8.9	Tests of arrester disconnector	101
11.8.10	Short-circuit tests	101
11.8.11	Test of the bending moment	101
11.8.12	Environmental tests	102
11.8.13	Seal leak rate test.....	102
11.8.14	Radio interference voltage (RIV) test	102
11.8.15	Test to verify the dielectric withstand of internal components	102
11.8.16	Test of internal grading components	102
11.9	Routine tests.....	102
11.10	Test after erection on site	102
12	Separable and dead-front arresters	102
12.1	Scope	102
12.2	Normative references.....	103
12.3	Terms and definitions.....	103

12.4	Identification and classification	103
12.5	Standard ratings and service conditions	103
12.6	Requirements	103
12.7	General testing procedure.....	104
12.8	Type tests (design tests).....	104
12.8.1	General	104
12.8.2	Insulation withstand tests	104
12.8.3	Residual voltage tests	106
12.8.4	Test to verify long term stability under continuous operating voltage.....	106
12.8.5	Test to verify the repetitive charge transfer rating, Q_{RS}	107
12.8.6	Heat dissipation behaviour of test sample	107
12.8.7	Operating duty tests	107
12.8.8	Power-frequency voltage versus time test.....	108
12.8.9	Tests of disconnectors	108
12.8.10	Short-circuit test	108
12.8.11	Test of the bending moment	109
12.8.12	Environmental tests	109
12.8.13	Seal leak rate test.....	109
12.8.14	Radio interference voltage (RIV) test	109
12.8.15	Test to verify the dielectric withstand of internal components.....	110
12.8.16	Test of internal grading components	110
12.8.17	Internal partial discharge test.....	110
12.9	Routine tests and acceptance tests.....	110
13	Liquid-immersed arresters	110
13.1	Scope	110
13.2	Normative references.....	111
13.3	Terms and definitions.....	111
13.4	Identification and classification	111
13.5	Standard ratings and service conditions	111
13.6	Requirements	111
13.7	General testing procedure.....	112
13.8	Type tests (design tests).....	112
13.8.1	General	112
13.8.2	Insulation withstand tests	112
13.8.3	Residual voltage tests	112
13.8.4	Test to verify long term stability under continuous operating voltage.....	113
13.8.5	Test to verify the repetitive charge transfer rating, Q_{RS}	113
13.8.6	Heat dissipation behaviour of test sample	114
13.8.7	Operating duty tests	114
13.8.8	Power frequency voltage-versus-time test.....	114
13.8.9	Tests of arrester disconnectors	114
13.8.10	Short-circuit tests	114
13.8.11	Test of the bending moment	116
13.8.12	Environmental tests	116
13.8.13	Seal leak rate test.....	117
13.8.14	Radio interference voltage (RIV) test	117
13.8.15	Test to verify the dielectric withstand of internal components.....	117
13.8.16	Test of internal grading components	117

13.9	Routine tests and acceptance tests.....	117
Annex A (normative)	Abnormal service conditions.....	118
Annex B (normative)	Test to verify thermal equivalency between complete arrester and arrester section	119
Annex C (normative)	Artificial pollution test with respect to the thermal stress on porcelain housed multi-unit metal-oxide surge arresters.....	121
C.1	Glossary	121
C.1.1	Measured quantities	121
C.1.2	Calculated quantities	121
C.2	General.....	122
C.3	Classification of site severity.....	125
C.4	Preliminary heating test: measurement of the thermal time constant τ and calculation of β	125
C.5	Verification of the need to perform the pollution tests	126
C.6	General requirements for the pollution test.....	126
C.6.1	Test sample.....	126
C.6.2	Testing plant.....	127
C.6.3	Measuring devices and measuring procedures	127
C.6.4	Test preparation	129
C.7	Test procedures	129
C.7.1	Slurry method	129
C.7.2	Salt fog method	131
C.8	Evaluation of test results.....	132
C.8.1	Calculation of K_{ie}	132
C.8.2	Calculation of the expected temperature rise ΔT_Z in service	133
C.8.3	Preparation for the operating duty test.....	133
C.9	Example.....	133
C.9.1	Preliminary heating test	134
C.9.2	Verification of the need to perform the pollution test	134
C.9.3	Salt fog tests	134
C.9.4	Calculation performed after five test cycles.....	135
C.9.5	Calculation performed after 10 test cycles	136
Annex D (informative)	Typical information given with enquiries and tenders.....	137
D.1	Information given with enquiry	137
D.1.1	System data	137
D.1.2	Service conditions	137
D.1.3	Arrester duty.....	137
D.1.4	Characteristics of arrester	138
D.1.5	Additional equipment and fittings	138
D.1.6	Any special abnormal conditions.....	138
D.2	Information given with tender	138
Annex E (informative)	Ageing test procedure – Arrhenius law – Problems with higher temperatures	139
Annex F (informative)	Guide for the determination of the voltage distribution along metal-oxide surge arresters	141
F.1	General.....	141
F.2	Modelling of the surge arrester	141
F.3	Modelling of the boundary conditions	142
F.4	Calculation procedure	142

F.4.1	Capacitive representation of the MO resistor column	142
F.4.2	Capacitive and resistive representation of the MO resistor column	143
F.4.3	Determination of U_{ct}	143
F.5	Example calculations	143
F.5.1	Modelling of the arrester and the boundary conditions	144
F.5.2	Resistive effects of the metal-oxide MO resistors	144
F.5.3	Results and conclusions from electric field calculations	144
Annex G (normative)	Mechanical considerations	149
G.1	Test of bending moment	149
G.2	Seismic test	150
G.3	Definition of mechanical loads	150
G.4	Definition of seal leak rate	151
G.5	Calculation of wind-bending-moment	152
G.6	Procedures of tests of bending moment for porcelain/cast resin and polymer-housed arresters	153
Annex H (normative)	Test procedure to determine the lightning impulse discharge capability	155
H.1	General	155
H.2	Selection of test samples	155
H.3	Test procedure	156
H.4	Test parameters for the lightning impulse discharge capability test	156
H.5	Measurements during the lightning impulse discharge capability test	156
H.6	Rated lightning impulse discharge capability	156
H.7	List of rated energy values	157
H.8	List of rated charge values	157
Annex I (normative)	Determination of the start temperature in tests including verification of thermal stability	158
Annex J (normative)	Determination of the average temperature of a multi-unit high-voltage arrester	159
Annex K (informative)	Example calculation of test parameters for the operating duty test (8.7) according to the requirements of 7.3	161
Annex L (informative)	Comparison of the old energy classification system based on line discharge classes and the new classification system based on thermal energy ratings for operating duty tests and repetitive charge transfer ratings for repetitive single event energies	162
Bibliography	168
Figure 1	– Illustration of power losses versus time during long term stability test	41
Figure 2	– Test procedure to verify the repetitive charge transfer rating, Q_{rs}	45
Figure 3	– Test procedure to verify the thermal energy rating, W_{th} , and the thermal charge transfer rating, Q_{th} , respectively	49
Figure 4	– Test procedure to verify the power frequency versus time characteristic (TOV test)	53
Figure 5	– Examples of arrester units	62
Figure 6	– Examples of fuse wire locations for “Design A” arresters	62
Figure 7	– Examples of fuse wire locations for “Design B” arresters	63
Figure 8	– Short-circuit test setup for porcelain-housed arresters	63
Figure 9	– Short-circuit test setup for polymer-housed arresters	82

Figure 10 – Example of a test circuit for re-applying pre-failing circuit immediately before applying the short-circuit test current	84
Figure 11 – Thermomechanical test	88
Figure 12 – Example of the test arrangement for the thermomechanical test and direction of the cantilever load	89
Figure 13 – Water immersion	90
Figure 14 – Test set-up for insulation withstand test of unscreened separable arresters	105
Figure C.1 – Flow-chart showing the procedure for determining the preheating of a test sample	124
Figure F.1 – Typical three-phase arrester installation.....	145
Figure F.2 – Simplified multi-stage equivalent circuit of an arrester.....	146
Figure F.3 – Geometry of arrester model	147
Figure F.4 – Example of voltage-current characteristic of MO resistors at +20 °C in the leakage current region	148
Figure F.5 – Calculated voltage stress along the MO resistor column in case B	148
Figure G.1 – Bending moment – multi-unit surge arrester	149
Figure G.2 – Definition of mechanical loads	151
Figure G.3 – Surge arrester unit	152
Figure G.4 – Surge-arrester dimensions	153
Figure G.5 – Flow chart of bending moment test procedures.....	154
Figure J.1 – Determination of average temperature in case of arrester units of same rated voltages	160
Figure J.2 – Determination of average temperature in case of arrester units of different rated voltages	160
Figure L.1 – Specific energy in kJ per kV rating dependant on the ratio of switching impulse residual voltage (U_a) to the r.m.s. value of the rated voltage U_r of the arrester	163
Table 1 – Arrester classification	26
Table 2 – Preferred values of rated voltages	27
Table 3 – Arrester type tests	35
Table 4 – Requirements for high current impulses	50
Table 5 – Rated values of thermal charge transfer rating, Q_{th}	52
Table 6 – Test requirements for porcelain housed arresters	61
Table 7 – Required currents for short-circuit tests	65
Table 8 – Test requirements for polymer-housed arresters.....	81
Table 9 – 10 kA and 20 kA three-phase GIS-arresters – Required withstand voltages	96
Table 10 – 2,5 kA and 5 kA three – phase – GIS arresters – Required withstand voltages	97
Table 11 – Insulation withstand test voltages for unscreened separable arresters	105
Table 12 – Insulation withstand test voltages for dead-front arresters or separable arresters in a screened/shielded housing	106
Table 13 – Partial discharge test values for separable and dead-front arresters	110
Table C.1 – Mean external charge for different pollution severities	125
Table C.2 – Characteristic of the sample used for the pollution test	127
Table C.3 – Requirements for the device used for the measurement of the charge	127

Table C.4 – Requirements for the device used for the measurement of the temperature	128
Table C.5 – Calculated values of $\Delta T_{Z \max}$ for the selected example	134
Table C.6 – Results of the salt fog test for the selected example	135
Table C.7 – Calculated values of ΔT_Z and of T_{OD} after 5 cycles for the selected example	136
Table C.8 – Calculated values of ΔT_Z and of T_{OD} after 10 cycles for the selected example	136
Table E.1 – Minimum demonstrated lifetime prediction.....	139
Table E.2 – Relationship between test durations at 115 °C and equivalent time at upper limit of ambient temperature.....	139
Table F.1 – Results from example calculations	145
Table L.1 – Peak currents for switching impulse residual voltage test	162
Table L.2 – Parameters for the line discharge test on 20 000 A and 10 000 A arresters	163
Table L.3 – Comparison of the classification system according to IEC 60099-4:2009 (Ed.2.2) and to IEC 60099-4:2014 (Ed.3.0)	165

INTRODUCTION

This part of IEC 60099 presents the minimum criteria for the requirements and testing of gapless metal-oxide surge arresters that are applied to a.c. power systems with U_s above 1 kV.

SURGE ARRESTERS –

Part 4: Metal-oxide surge arresters without gaps for a.c. systems

1 Scope

This part of IEC 60099 applies to non-linear metal-oxide resistor type surge arresters without spark gaps designed to limit voltage surges on a.c. power circuits with U_s above 1 kV.

2 Normative references

The following documents, in whole or in part, are normatively referenced in this document and are indispensable for its application. For dated references, only the edition cited applies. For undated references, the latest edition of the referenced document (including any amendments) applies.

IEC 60060-1, *High-voltage test techniques – Part 1: General definitions and test requirements*

IEC 60060-2, *High-voltage test techniques – Part 2: Measuring systems*

IEC 60068-2-11:1981, *Environmental testing – Part 2-11: Tests – Test kA: Salt mist*

IEC 60068-2-14, *Environmental testing – Part 2-14: Tests – Test N: Change of temperature*

IEC 60071-1, *Insulation co-ordination – Part 1: Definitions, principles and rules*

IEC 60071-2:1996, *Insulation co-ordination – Part 2: Application guide*

IEC 60270, *High-voltage test techniques – Partial discharge measurements*

IEC 60507:2013, *Artificial pollution tests on high-voltage insulators to be used on a.c. systems*

IEC TS 60815-1:2008, *Selection and dimensioning of high voltage insulators intended for use in polluted conditions – Part 1: Definitions, information and general principles*

IEC TS 60815-2:2008, *Selection and dimensioning of high voltage insulators intended for use in polluted conditions – Part 2: Ceramic and glass insulators for a.c. systems*

IEC 62217, *Polymeric insulators for indoor and outdoor use – General definitions, test methods and acceptance criteria*

IEC 62271-1:2007, *High-voltage switchgear and controlgear – Part 1: Common specifications*

IEC 62271-200:2011, *High-voltage switchgear and controlgear – Part 200: A.C. metal-enclosed switchgear and controlgear for rated voltages above 1 kV and up to and including 52 kV*

IEC 62271-203:2011, *High-voltage switchgear and controlgear – Part 203: Gas-insulated metal-enclosed switchgear for rated voltages above 52 kV*

ISO 4287, *Geometrical Product Specifications (GPS) – Surface texture: Profile method – Terms, definitions and surface texture parameters*

ISO 4892-1, *Plastics – Methods of exposure to laboratory light sources - Part 1: General guidance*

ISO 4892-2, *Plastics – Methods of exposure to laboratory light sources – Part 2: Xenon-arc lamps*

ISO 4892-3, *Plastics – Methods of exposure to laboratory light sources – Part 3: Fluorescent UV lamps*

CISPR/TR 18-2, *Radio interference characteristics of overhead power lines and high-voltage equipment – Part 2: Methods of measurement and procedure for determining limits*

3 Terms and definitions

For the purposes of this document, the following definitions apply.

3.1

acceptance tests

tests made on arresters or representative samples after agreement between manufacturer and user

3.2

arrester – dead-front type

dead-front arrester

arrester assembled in a screened/shielded housing providing system insulation and conductive ground shield, intended to be installed in an enclosure for the protection of underground and pad-mounted distribution equipment and circuits

Note 1 to entry: The use of dead-front arresters is common in the USA. Most dead-front arresters are load-break arresters.

Note 2 to entry: The arresters are assembled in an insulated housing with varying levels of shielding and screening as determined by safety or contact requirements for the installation. The differences between the descriptions from one manufacturer to another in regard to shielding, screening and degrees of such can be very subtle, but the focus is on safety and conductivity of the exterior housing to either permit, or not, workers to handle the arresters energized and with or without live line tools.

3.3

arrester disconnecter

device for disconnecting an arrester from the system in the event of arrester failure, to prevent a persistent fault on the system and to give visible indication of the failed arrester

Note 1 to entry: Clearing of the fault current through the arrester during disconnection generally is not a function of the device.

3.4

arrester – liquid-immersed type

liquid-immersed arrester

arrester designed to be immersed in an insulating liquid

3.5

arrester – separable type

separable arrester

arrester assembled in an insulated or screened/shielded housing providing system insulation, intended to be installed in an enclosure for the protection of distribution equipment and systems

Note 1 to entry: The use of separable arresters is common in Europe. Electrical connection may be made by sliding contact or by bolted devices; however, all separable arresters are dead-break arresters.

Note 2 to entry: The arresters are assembled in an insulated housing with varying levels of shielding and screening as determined by safety or contact requirements for the installation. The differences between the descriptions from one manufacturer to another in regard to shielding, screening and degrees of such can be very subtle, but the focus is on safety and conductivity of the exterior housing to either permit, or not, workers to handle the arresters energized and with or without live line tools.

3.6 bending moment

force perpendicular to the longitudinal axis of an arrester multiplied by the vertical distance between the mounting base (lower level of the flange) of the arrester and the point of application of the force

3.7 breaking load

force perpendicular to the longitudinal axis of a porcelain-housed or cast resin arrester leading to mechanical failure of the arrester housing

3.8 cast resin housed arrester

arrester using a housing made from only one organic based material (e.g. cycloaliphatic epoxy) that fractures similarly to a porcelain housing under mechanical overstress

3.9 continuous current of an arrester

current flowing through the arrester when energized at the continuous operating voltage

Note 1 to entry: The continuous current, which consists of a resistive and a capacitive component, may vary with temperature, stray capacitance and external pollution effects. The continuous current of a test sample may, therefore, not be the same as the continuous current of a complete arrester.

Note 2 to entry: The continuous current is, for comparison purposes, expressed either by its r.m.s. or peak value.

3.10 continuous operating voltage of an arrester

U_c
designated permissible r.m.s. value of power-frequency voltage that may be applied continuously between the arrester terminals in accordance with 8.7

3.11 damage limit (mechanical)

lowest value of a force perpendicular to the longitudinal axis of a polymer-housed arrester leading to mechanical failure of the arrester housing

3.12 dead-break arrester

arrester which can be connected and disconnected from the circuit only when the circuit is de-energized

3.13 designation of an impulse shape

combination of two numbers, the first representing the virtual front time (T_1) and the second the virtual time to half-value on the tail (T_2)

Note 1 to entry: It is written as T_1/T_2 , both in microseconds, the sign "/" having no mathematical meaning.

3.14 discharge current of an arrester

impulse current which flows through the arrester

3.15 disruptive discharge

phenomenon associated with the failure of insulation under electric stress, which includes a collapse of voltage and the passage of current

Note 1 to entry: The term applies to electrical breakdowns in solid, liquid and gaseous dielectric, and combinations of these.

Note 2 to entry: A disruptive discharge in a solid dielectric produces permanent loss of electric strength. In a liquid or gaseous dielectric the loss may be only temporary.

3.16 distribution class arrester

arrester intended for use on distribution systems, typically of $U_s \leq 52$ kV, to protect components primarily from the effects of lightning

Note 1 to entry: Distribution class arresters may have nominal discharge currents, I_n , of 2,5 kA; 5 kA or 10 kA.

Note 2 to entry: Distribution arresters are classified as “Distribution DH”, “Distribution DM” and “Distribution DL” (see Table 1).

3.17 electrical unit

portion of an arrester in which each end of the unit is terminated with an electrode which is exposed to the external environment

Note 1 to entry: An electrical unit may have more than one mechanical unit (see Figure 5).

3.18 fail-open current rating for liquid-immersed arrester

fault current level above which the arrester is claimed to evolve into an open circuit upon failure

3.19 fail-short current rating for liquid-immersed arrester

fault current level below which the arrester is claimed to evolve into a short-circuit upon failure

3.20 fault indicator

device intended to provide an indication that the arrester is faulty and which does not disconnect the arrester from the system

3.21 flashover

disruptive discharge over a solid surface

3.22 front of an impulse

part of an impulse which occurs prior to the peak

3.23 gas-insulated metal enclosed surge arrester GIS-arrester

gas-insulated metal-enclosed metal-oxide surge arrester without any integrated series or parallel spark gaps, filled with gas other than air

Note 1 to entry: The gas pressure is normally higher than 1 bar = 10^5 Pa.

Note 2 to entry: A surge arrester used in gas-insulated switchgear.

3.24**grading ring of an arrester**

metal part, usually circular in shape, mounted to modify electrostatically the voltage distribution along the arrester

3.25**high current impulse of an arrester**

peak value of discharge current having a 4/10 impulse shape which is used to test the stability of the arrester on direct lightning strokes

3.26**housing**

external insulating part of an arrester, which provides the necessary creepage distance and protects the internal parts from the environment

Note 1 to entry: A housing may consist of several parts providing mechanical strength and protection against the environment.

Note 2 to entry: Where the definition of a housing would differ from this for special types of arresters (e.g. for GIS, deadfront/separable and liquid immersed arresters), alternative definitions are given in clauses specific to those arresters (e.g. Clauses 11, 12 and 13).

3.27**impulse**

unidirectional wave of voltage or current which, without appreciable oscillations, rises rapidly to a maximum value and falls, usually less rapidly, to zero with small, if any, excursions of opposite polarity, with defining parameters being polarity, peak value, front time and time to half-value on the tail

3.28**insulating base**

a short insulator (or set of insulators) on which the arrester is mounted to provide a means of connecting a current monitoring device between the base of the arrester and earth

3.29**internal grading system of an arrester**

grading impedances, in particular grading capacitors connected in parallel to one single or to a group of non-linear MO resistors, to control the voltage distribution along the MO resistor stack

3.30**internal parts**

MO resistor with supporting structure and internal grading system, if equipped

3.31**lightning current impulse**

8/20 current impulse with limits on the adjustment of equipment such that the measured values are from 7 μs to 9 μs for the virtual front time and from 18 μs to 22 μs for the time to half-value on the tail

Note 1 to entry: The time to half-value on the tail is not critical and may have any tolerance during the residual voltage type tests (see 8.3).

3.32**lightning impulse discharge**

an approximately sine half-wave current impulse having a time duration within 200 μs to 230 μs during which the instantaneous value of the impulse current is greater than 5 % of its peak value

3.33**lightning impulse protection level****LIPL or U_{pl}**

the maximum residual voltage of the arrester for the nominal discharge current

3.34**load-break arrester**

arrester which can be connected and disconnected when the circuit is energized

3.35**long-duration current impulse**

rectangular current impulse which rises rapidly to maximum value, remains substantially constant for a specified period and then falls rapidly to zero, with defining parameters being polarity, peak value, virtual duration of the peak and virtual total duration.

3.36**mean breaking load****MBL**

the average breaking load for porcelain or cast resin-housed arresters determined from tests

3.37**mechanical unit**

portion of an arrester in which the MO resistors within the unit are mechanically restrained from moving in an axial direction

Note 1 to entry: An arrester may contain more than one mechanical units within an electrical unit (see Figure 5).

Note 2 to entry: A mechanical unit may have more than one electrical unit (see Figure 5).

3.38**metal-oxide surge arrester without gaps**

arrester having non-linear MO resistors connected in series and/or in parallel without any integrated series or parallel spark gaps, incorporated in a housing with terminals for electrical and mechanical connection

Note 1 to entry: Wherever the term “arrester” or “surge arrester” is used in this document, the term refers to a metal-oxide surge arrester without gaps.

3.39**mounting bracket**

means by which a distribution class arrester is physically attached to a pole or other structure

Note 1 to entry: For polymer housed distribution class arresters, the mounting bracket is typically of an insulating material and is typically attached to the bottom (ground) end of the arrester; for porcelain-housed distribution class arresters, the bracket is typically metal (often steel) and is connected by a “belly band” around the porcelain housing at some distance from the ground end of the arrester.

3.40**nominal discharge current of an arrester** **I_n**

peak value of lightning current impulse, which is used to classify an arrester

3.41**non-gapped line arrester****NGLA**

arrester without internal or external series gaps intended for installation in overhead lines in parallel to the line insulators in order to prevent flashovers

3.42**non-linear metal-oxide resistor
MO resistor**

part of the surge arrester which, by its non-linear voltage versus current characteristics, acts as a low resistance to overvoltages, thus limiting the voltage across the arrester terminals, and as a high resistance at normal power-frequency voltage

3.43**peak (crest) value of an impulse**

maximum value of a voltage or current impulse

Note 1 to entry: Superimposed oscillations may be disregarded.

3.44**peak (crest) value of opposite polarity of an impulse**

maximum amplitude of opposite polarity reached by a voltage or current impulse when it oscillates about zero before attaining a permanent zero value

3.45**polymer-housed surge arrester**

arrester using polymeric and composite materials for housing

Note 1 to entry: Designs with an enclosed gas volume are possible. Sealing may be accomplished by use of the polymeric material itself or by a separate sealing system.

3.46**porcelain-housed surge arrester**

arrester using porcelain as housing material, with fittings and sealing systems

3.47**power-frequency voltage versus time characteristic of an arrester**

the maximum time durations for which corresponding power-frequency voltages may be applied to arresters without causing damage or thermal instability, under specified conditions in accordance with 6.12

3.48**pressure-relief device of an arrester**

means for relieving internal pressure in an arrester and preventing violent shattering of the housing following prolonged passage of fault current or internal flashover of the arrester

3.49**prospective current of a circuit**

current that would flow at a given location in a circuit if it were short-circuited at that location by a link of negligible impedance

3.50**protective characteristics of an arrester**

a combination of lightning impulse protection level (LIPL), switching impulse protection level (SIPL) and steep current impulse protection level (STIPL)

3.51**puncture (breakdown)**

disruptive discharge through a solid

3.52**rated frequency of an arrester**

frequency of the power system on which the arrester is designed to be used

3.53 rated short-circuit current

 I_s

highest tested power-frequency current that may develop in a failed arrester as a short-circuit current without causing violent shattering of the housing or any open flames for more than two minutes under the specified test conditions

3.54 rated voltage of an arrester

 U_r

maximum permissible 10 s power frequency r.m.s. overvoltage that can be applied between the arrester, as verified in the TOV test and the operating duty test

Note 1 to entry: The rated voltage is used as a reference parameter for the specification of operating characteristics.

3.55 reference current of an arrester

peak value (the higher peak value of the two polarities if the current is asymmetrical) of the resistive component of a power-frequency current used to determine the reference voltage of the arrester

Note 1 to entry: The reference current should be high enough to make the effects of stray capacitances at the measured reference voltage of the arrester units (with designed grading system) negligible and is to be specified by the manufacturer. The reference current will be typically in the range of 0,05 mA to 1,0 mA per square centimetre of disc area for single column arresters.

3.56 reference voltage of an arrester

 U_{ref}

peak value of power-frequency voltage divided by $\sqrt{2}$, which is obtained when the reference current flows through the arrester

Note 1 to entry: The reference voltage of a multi-unit arrester is the sum of the reference voltages of the individual units.

Note 2 to entry: Measurement of the reference voltage is necessary for the selection of a correct test sample in the operating duty test (see 8.7).

3.57 repetitive charge transfer rating

 Q_{rs}

maximum specified charge transfer capability of an arrester, in the form of a single event or group of surges that may be transferred through an arrester without causing mechanical failure or unacceptable electrical degradation to the MO resistors

Note 1 to entry: The charge is calculated as the absolute value of current integrated over time. For the purpose of this standard this is the charge that is accumulated in a single event or group of surges lasting for not more than 2 s and which may be followed by a subsequent event at a time interval not shorter than 60 s.

3.58 residual voltage of an arrester

 U_{res}

peak value of voltage that appears between the terminals of an arrester during the passage of discharge current

Note 1 to entry: The term "discharge voltage" is used in some countries.

3.59 routine tests

tests made on each arrester, or on parts and materials, as required, to ensure that the product meets the design specifications

3.60

seal (gas/water tightness)

ability of an arrester to avoid ingress of matter affecting the electrical and/or mechanical behaviour

3.61

section of an arrester (prorated section)

complete, suitably assembled part of an arrester necessary to represent the behaviour of a complete arrester with respect to a particular test

Note 1 to entry: A section of an arrester is not necessarily a unit of an arrester. For certain tests, a MO resistor alone constitutes a section.

3.62

shed

insulating part projecting from the housing, intended to increase the creepage distance

3.63

specified long-term load

SLL

force perpendicular to the longitudinal axis of an arrester, allowed to be continuously applied during service without causing any mechanical damage to the arrester

3.64

specified short-term load

SSL

greatest force perpendicular to the longitudinal axis of an arrester, allowed to be applied during service for short periods and for relatively rare events (for example, short-circuit current loads and extreme wind gusts) without causing any mechanical damage to the arrester

Note 1 to entry: SSL does not relate to mechanical strength requirements for seismic loads. See G.2.

3.65

station class arrester

arresters intended for use in stations to protect the equipment from transient overvoltages, typically but not only intended for use on systems of $U_s \geq 72,5$ kV

Note 1 to entry: Station class arresters may have nominal discharge currents, I_n , of 10 kA or 20 kA.

Note 2 to entry: Station class arresters are classified as “Station SH”, “Station SM” and “Station SL” (see Table 1).

Note 3 to entry: Station class arresters may also be used in distribution systems of $U_s \leq 52$ kV.

3.66

steep current impulse

current impulse with a virtual front time of $1 \mu\text{s}$ with limits in the adjustment of equipment such that the measured values are from $0,9 \mu\text{s}$ to $1,1 \mu\text{s}$ and the virtual time to half-value on the tail is not longer than $20 \mu\text{s}$

Note 1 to entry: The time to half-value on the tail is not critical and may have any tolerance during the residual voltage type tests (see 8.3).

3.67

steep current impulse protection level

STIPL

the maximum residual voltage of the arrester for a steep current impulse of magnitude equal to the magnitude of the nominal discharge current

3.68**switching current impulse of an arrester**

peak value of discharge current having a virtual front time greater than 30 μs but less than 100 μs and a virtual time to half-value on the tail of roughly twice the virtual front time

3.69**switching impulse protection level****SIPL or U_{ps}**

the maximum residual voltage of the arrester for the switching impulse discharge current specified for its class

3.70**tail of an impulse**

part of an impulse which occurs after the peak

3.71**terminal line force**

force perpendicular to the longitudinal axis of the arrester measured at the centre line of the arrester

3.72**thermal charge transfer rating** **Q_{th}**

maximum specified charge that may be transferred through an arrester or arrester section within 3 minutes in a thermal recovery test without causing a thermal runaway

Note 1 to entry: This rating is verified by the operating duty type test.

3.73**thermal energy rating** **W_{th}**

maximum specified energy, given in kJ/kV of U_r , that may be injected into an arrester or arrester section within 3 minutes in a thermal recovery test without causing a thermal runaway

Note 1 to entry: This rating is verified by the operating duty type test.

3.74**thermal runaway of an arrester**

situation when the sustained power loss of an arrester exceeds the thermal dissipation capability of the housing and connections, leading to a cumulative increase in the temperature of the MO resistor elements culminating in failure

3.75**thermal stability of an arrester**

state of an arrester if, after an operating duty causing temperature rise, the temperature of the MO resistors decreases with time when the arrester is energized at specified continuous operating voltage and at specified ambient conditions

3.76**torsional loading**

each horizontal force at the top of a vertical mounted arrester housing which is not applied to the longitudinal axis of the arrester

3.77**type tests****design tests**

tests which are made upon the completion of the development of a new arrester design to establish representative performance and to demonstrate compliance with the relevant standard

Note 1 to entry: Once made, these tests need not be repeated unless the design is changed so as to modify its performance. In such a case, only the relevant tests need be repeated.

3.78

unipolar sine half-wave current impulse

a unipolar current impulse consisting of one half-cycle of an approximately sinusoidal current

3.79

unit of an arrester arrester unit

completely housed part of an arrester which may be connected in series and/or in parallel with other units to construct an arrester of higher voltage and/or current rating

3.80

virtual duration of the peak of a rectangular impulse

time during which the amplitude of the impulse is greater than 90 % of its peak value

3.81

virtual front time of a current impulse

T_1

time in microseconds equal to 1,25 multiplied by the time in microseconds for the current to increase from 10 % to 90 % of its peak value

Note 1 to entry: If oscillations are present on the front, the reference points at 10 % and 90 % should be taken on the mean curve drawn through the oscillations.

3.82

virtual origin of an impulse

point on a graph of voltage versus time or current versus time determined by the intersection between the time axis at zero voltage or zero current and the straight line drawn through two reference points on the front of the impulse

Note 1 to entry: For current impulses the reference points shall be 10 % and 90 % of the peak value.

Note 2 to entry: This definition applies only when scales of both ordinate and abscissa are linear.

Note 3 to entry: If oscillations are present on the front, the reference points at 10 % and 90 % should be taken on the mean curve drawn through the oscillations.

3.83

virtual steepness of the front of an impulse

quotient of the peak value and the virtual front time of an impulse

3.84

virtual time to half-value on the tail of an impulse

T_2

time interval between the virtual origin and the instant when the voltage or current has decreased to half its peak value, expressed in microseconds

3.85

virtual total duration of a rectangular impulse

time during which the amplitude of the impulse is greater than 10 % of its peak value

Note 1 to entry: If small oscillations are present on the front, a mean curve should be drawn in order to determine the time at which the 10 % value is reached.

4 Identification and classification

4.1 Arrester identification

Metal-oxide surge arresters shall be identified by the following minimum information which shall appear on a nameplate permanently attached to the arrester:

designation of arrester (see Table 1)

continuous operating voltage;

rated voltage;

rated frequency, if other than one of the standard frequencies (see 5.2);

nominal discharge current;

rated short-circuit current in kiloamperes (kA). For arresters for which no short-circuit rating is claimed, the value "0" shall be indicated;

the manufacturer's name or trade mark, type and identification of the complete arrester;

identification of the assembling position of the unit (for multi-unit arresters only);

the year of manufacture;

serial number (at least for arresters with rated voltage above 60 kV).

If sufficient space is available the nameplate should also contain

repetitive charge transfer rating, Qrs;

contamination withstand level of the enclosure (see IEC TS 60815-1).

4.2 Arrester classification

Station and distribution class arresters are classified as indicated in Table 1, and they shall meet at least the test requirements and performance characteristics specified in Table 3.

Depending on application, NGLA may take on the classification of any one of the arresters indicated in Table 1.

Table 1 – Arrester classification

Arrester class	Station			Distribution		
	SH	SM	SL	DH	DM	DL
Designation						
Nominal discharge current ^a	20 kA	10 kA	10 kA	10 kA	5 kA	2,5 kA
Switching impulse discharge current ^a	2 kA	1 kA	0,5 kA	--	--	--
Q _{rs} (C)	≥ 2,4	≥ 1,6	≥ 1,0	≥ 0,4	≥ 0,2	≥ 0,1
W _{th} (kJ/kV)	≥ 10	≥ 7	≥ 4	--	--	--
Q _{th} (C)	--	--	--	≥ 1,1	≥ 0,7	≥ 0,45

^a Other currents may be specified upon agreement between manufacturer and user.

NOTE The letters "H", "M" and "L" in the designation stand for "high", "medium" and "low" duty, respectively.

5 Standard ratings and service conditions

5.1 Standard rated voltages

Standard values of rated voltages for arresters (in kilovolts r.m.s.) are specified in Table 2 in equal voltage steps within specified voltage ranges.

Table 2 – Preferred values of rated voltages

Range of rated voltage kV r.m.s.	Steps of rated voltage kV r.m.s.
3 to 30	1
30 to 54	3
54 to 96	6
96 to 288	12
288 to 396	18
396 to 900	24

Other values of rated voltages may be accepted.

5.2 Standard rated frequencies

The standard rated frequencies are 50 Hz and 60 Hz.

5.3 Standard nominal discharge currents

The standard nominal 8/20 discharge currents are: 20 kA, 10 kA, 5 kA, and 2,5 kA.

5.4 Service conditions

5.4.1 Normal service conditions

Surge arresters which conform to this standard shall be suitable for normal operation under the following normal service conditions:

- a) ambient air temperature within the range of -40 °C to $+40\text{ °C}$;
- b) solar radiation;

NOTE The effects of maximum solar radiation ($1,1\text{ kW/m}^2$) have been taken into account by preheating the test specimen in the type tests. Other heat sources that may affect the application of the arrester are not considered under normal service condition.,
- c) altitude not exceeding 1 000 m;
- d) frequency of the a.c. power supply not less than 48 Hz and not exceeding 62 Hz;
- e) power-frequency voltage applied continuously between the terminals of the arrester not exceeding its continuous operating voltage;
- f) wind speeds $\leq 34\text{ m/s}$;
- g) vertical erection, not suspended.

5.4.2 Abnormal service conditions

Surge arresters subject to other than normal application or service conditions may require special consideration in design, manufacture or application. The use of this standard in case of abnormal service conditions is subject to agreement between the manufacturer and the user. A list of possible abnormal service conditions is given in Annex A.

6 Requirements

6.1 Insulation withstand

The arrester shall be designed such that the housings are able to adequately withstand voltages during conduction of lightning and switching impulse currents and during anticipated maximum power frequency overvoltages. The external insulation withstand capability of the housings shall be demonstrated by tests according to 8.2, while the internal insulation withstand capability shall be demonstrated by tests according to 8.15.

6.2 Reference voltage

The reference voltage of each arrester shall be measured by the manufacturer at the reference current selected by the manufacturer (see 7.2). The minimum reference voltage of the arrester at the reference current used for routine tests shall be specified and published in the manufacturer's data.

6.3 Residual voltages

The purpose of the measurement of residual voltages is to obtain the maximum residual voltages for a given design for all specified currents and wave shapes. These are derived from the type test data and from the maximum residual voltage at a lightning current impulse used for routine tests as specified and published by the manufacturer.

The maximum residual voltage of a given arrester design for any current and wave shape is calculated from the residual voltage of sections tested during type tests multiplied by a specific scale factor. This scale factor is equal to the ratio of the declared maximum residual voltage, as checked during the routine tests, to the measured residual voltage of the sections at the same current and wave shape.

For some arresters with a rated voltage of less than 36 kV (as per NOTE 1 of 9.1, item b)), the reference voltage may be used for this calculation instead of the residual voltage.

Manufacturers' literature shall contain, for each arrester listed, the following residual voltage information:

Maximum lightning impulse residual voltage for impulse currents of at least 0,5; 1 and 2 times the nominal discharge current of the arrester (see 8.3.3)

Maximum switching impulse residual voltage for impulse currents given in Table 1 (see 8.3.4)

Maximum steep current impulse residual voltage, excluding inductive voltage contribution, for an impulse current having peak value equal to the nominal discharge current of the arrester (see 8.3.2)

Maximum steep current impulse residual voltage, including inductive voltage contribution for an impulse current having peak value equal to the nominal discharge current of the arrester. This residual voltage shall be equal to

Maximum steep current impulse residual voltage (see 8.3.2), excluding inductive voltage contribution + Magnitude of inductive voltage drop

where, for AIS arresters,

Magnitude of inductive voltage drop = 2,5; 5; 10 or 20 kV/m of arrester length for arresters with nominal discharge current of 2,5; 5; 10 or 20 kA, respectively

or, for GIS and separable and dead-front arresters,

Magnitude of inductive voltage drop = 0,75; 1,5; 3 or 6 kV/m of arrester length for arresters with nominal discharge current of 2,5; 5; 10 or 20 kA, respectively

NOTE 1 The contribution of inductive voltage drop is significant only for steep current impulses. It effectively increases the protection level of the arrester above the MO resistor-only steep current impulse

residual voltage determined from 8.3.2. The maximum steep current impulse residual voltage including inductive voltage contribution is provided for users who wish to perform insulation coordination studies.

NOTE 2 Typical maximum residual voltages for different types of arrester are given in Annex F of IEC 60099-5: 2013.

6.4 Internal partial discharges

Under normal and dry operating conditions, internal partial discharges shall be below a level that might cause damage to internal parts. This shall be demonstrated by routine test according to item c) of 9.1.

6.5 Seal leak rate

For arresters having an enclosed gas volume and a separate sealing system, seal leak rates shall be specified as defined in 8.13 and item d) of 9.1.

6.6 Current distribution in a multi-column arrester

The manufacturer shall specify the highest allowed difference between currents in columns of a multi-column arrester, see item e) of 9.1.

6.7 Thermal stability

When agreed between manufacturer and user, a special thermal stability test may be performed according to 9.2.2.

6.8 Long term stability under continuous operating voltage

MO resistors shall be subjected to an accelerated ageing test to provide assurance that they will exhibit stable conditions over the anticipated lifetime of the arrester (see 8.4)

6.9 Heat dissipation behaviour of test sample

Pro-rated sections used for tests involving thermal recovery shall have thermal properties that do not result in over-estimation of arrester performance. Tests shall be performed to validate the heat dissipation behaviour of the pro-rated sections (see 8.6)

6.10 Repetitive charge transfer withstand

Arresters shall withstand repetitive charge transfers as checked during type tests (see 8.5).

The repetitive charge transfer withstand is demonstrated on individual MO resistors in the test to verify the repetitive charge transfer rating (see 8.5.2).

NOTE There may be special applications where single event charge transfers cause energy dissipations higher than the rated thermal energy rating.

6.11 Operating duty

Arresters shall be able to absorb energy from switching events or transfer charge from lightning events and subsequently thermally recover under applied temporary overvoltage and following continuous operating voltage conditions. This capability is demonstrated by the operating duty test (see 8.7).

6.12 Power-frequency voltage versus time characteristics of an arrester

The manufacturer shall supply data on the allowable time duration of power-frequency voltage and the corresponding voltage value which may be applied to the arrester after the arrester has been preheated to the start temperature as per 8.7.2.3 without damage or thermal runaway. The data shall be given without prior energy or charge duty and – in case of $I_n \geq$

10 kA – with prior duty corresponding to the thermal energy rating W_{th} or the thermal charge transfer rating Q_{th} .

This information shall be presented as power-frequency voltage versus time curves (TOV curves) with the energy or charge duty prior to this power-frequency voltage application stated on the above-mentioned curve.

The TOV characteristic is demonstrated on thermally prorated sections in the test to verify the power frequency voltage versus time characteristic (TOV test) (see 8.8).

6.13 Short-circuit performance

The manufacturer shall declare a short-circuit current rating for each family of arresters. Only for applications with expected short-circuit currents below 1 kA the rated value “zero” may be claimed. In this case “0” shall be indicated on the name plate. In any case, the arrester shall be subjected to a short-circuit test according to 8.10 to show that it will not fail in a manner that causes violent shattering of the housing and that self-extinguishing of open flames (if any) occurs within a defined period of time.

6.14 Disconnecter

6.14.1 Disconnecter withstand

When an arrester is fitted or associated with a disconnecter, this device shall withstand, without operating, each of the following tests:

For distribution class arresters:

- test to verify the repetitive charge transfer rating, Q_{rs} (see 8.5.2);
- operating duty test with rated values of thermal charge rating, Q_{th} (see 8.7.2);
- mechanical tests on agreement between manufacturer and user (see NOTES 1 and 2 of 8.9.4.1)
- temperature cycling and seal pumping test (see 8.9.5)

For non-gapped line arresters (NGLA):

- test to verify the repetitive charge transfer rating, Q_{rs} with lightning impulse discharges according to Annex H or long duration currents (see 8.5.2);
- operating duty test with rated values of thermal energy rating, W_{th} (see 8.7.2);
- bending moment test (see 8.9.4.2);
- tensile load test (see 8.9.4.3);
- torsional load test (see 8.9.4.4);
- temperature cycling and seal pumping test (see 8.9.5)

6.14.2 Disconnecter operation

The time delay for the operation of the disconnecter is determined for three values of current according to 8.9.3. There shall be clear evidence of effective and permanent disconnection by the device.

6.15 Requirements on internal grading components

Internal grading components, if used in the arrester, shall be able to withstand the combination of stresses arising in service, and the impedance of the grading components shall also show sufficient stability during the service life. This shall be demonstrated by operating duty test (see 8.7) and the TOV test (see 8.8) being performed with internal grading components included in the test sections.

Furthermore, the components shall withstand the accelerated ageing and cyclic tests as specified in 8.16.

6.16 Mechanical loads

6.16.1 General

The manufacturer shall specify the maximum permissible terminal loads relevant for installation and service, such as cantilever, torque and tensile loads.

6.16.2 Bending moment

The arrester shall be able to withstand the manufacturer's declared values for bending loads (see 8.11).

When determining the mechanical load applied to a surge arrester, the user should consider, for example, wind, ice and electromagnetic forces likely to affect the installation.

Surge arresters enclosed within their package should withstand the transportation loads specified by the user in accordance with IEC 60721-3-2, but not less than Class 2M1.

NOTE Unlike porcelain-housed arresters, polymer-housed arresters may show mechanical deflections in service.

6.16.3 Resistance against environmental stresses

The arrester shall be able to withstand environmental stresses as defined in 8.12.

6.16.4 Insulating base and mounting bracket

When an insulating base and/or a mounting bracket is provided with the arrester, the base and/or bracket shall be subjected to mechanical tests separately from the arrester (see 8.11.6).

6.16.5 Mean value of breaking load (MBL)

For porcelain and cast-resin housed arresters the MBL shall be $\geq 1,2$ times the specified short-term load (SSL). This shall be demonstrated in the bending moment test of 8.11.

6.16.6 Electromagnetic compatibility

Arresters are not sensitive to electromagnetic disturbances and therefore no immunity test is necessary.

In normal dry operating conditions, surge arresters shall not emit significant disturbances. For arresters intended for use on systems of $U_s \geq 72,5$ kV, this shall be demonstrated by a radio interference voltage test (RIV) according to 8.14.

6.17 End of life

On request from users, each manufacturer shall give enough information so that all the arrester components may be scrapped and/or recycled in accordance with international and national regulations.

6.18 Lightning impulse discharge capability

For NGLA arresters to be installed in overhead lines with system voltages exceeding 52 kV, the lightning impulse discharge capability shall be demonstrated by the tests and procedures of Annex H.

7 General testing procedure

7.1 Measuring equipment and accuracy

The measuring equipment shall meet the requirements of IEC 60060-2. The values obtained shall be accepted as accurate for the purpose of compliance with the relevant test clauses.

Unless stated elsewhere, all tests with power-frequency voltages shall be made with an alternating voltage having a frequency between the limits of 48 Hz and 62 Hz and an approximately sinusoidal wave shape.

7.2 Reference voltage measurements

The reference voltage of an arrester is measured at the reference current on sections and units when required. The measurement shall be performed at an ambient temperature of $20\text{ °C} \pm 15\text{ K}$, and this temperature shall be recorded.

As an acceptable approximation, the peak value of the resistive component of current may be taken to correspond to the momentary value of the current at the instant of voltage peak.

7.3 Test samples

7.3.1 General

Unless otherwise specified, all tests shall be made on the same arresters, arrester sections or arrester units. They shall be new, clean, completely assembled (for example, with grading rings if applicable) and arranged to simulate as closely as possible the conditions in service.

For tests involving verification of thermal stability the sections shall contain the highest number of parallel columns of MO resistors that is assembled within one arrester housing for the actual design.

When tests are made on sections it is necessary that the sections represent the behaviour of all possible arresters within the manufacturer's tolerances with respect to a specific test.

NOTE Due to the usually very complex internal design of GIS arresters, it may not be practical to carry out the test on test samples with many MO resistor columns in parallel. On the other hand, to achieve thermal equivalence with single-column sections is more realistic in GIS arresters than in AIS arresters because of their better cooling characteristic. Therefore, for GIS arresters single-column sections are accepted if thermal equivalence as per Annex B can be proven.

In general, the samples shall cover the highest residual voltage and the lowest reference voltage of the type of MO resistors used in the arrester. If thermal charge transfer rating is specified in the operating duty test and for the TOV test (see 8.7 and 8.8) the samples shall have the highest lightning impulse protection level U_{pl} per unit length of the design. If thermal energy rating is specified in the operating duty test the test samples shall have a reference voltage value at the lower end of the variation range declared by the manufacturer. In case of multi-column arresters, the highest value of uneven current distribution shall be considered. In order to comply with these demands the following shall be fulfilled:

- a) The ratio between the rated voltage of the complete arrester to the rated voltage of the section is defined as n . The volume of the MO resistor elements used as test samples shall not be greater than the minimum volume of all MO resistor elements used in the complete arrester divided by n .
- b) The reference voltage of the test section shall be equal to $k U_r/n$ where k is the ratio between the minimum reference voltage of the arrester and its rated voltage. If $U_{ref} \geq k U_r/n$ for an available test sample, the factor n shall be reduced correspondingly. (If $U_{ref} < k U_r/n$ the arrester may absorb too much energy. Such a section can be used only after agreement from the manufacturer.)

- c) For multi-column arresters the distribution of the current between the columns shall be measured at the impulse current for current distribution test (see item e) of 9.1). The highest current value shall not be higher than an upper limit specified by the manufacturer. Furthermore, for tests that are required to be performed on test sections with multiple columns the discharge energy shall be increased by a factor β_g/β_a where β_g is the guaranteed current sharing factor and β_a is the actual current sharing factor for the test section. If the test is performed on single columns the energy shall be increased by a factor β_g .
- d) The samples in the test to verify the repetitive charge transfer rating shall be of the longest length of the type of MO resistors used in the design, and shall have a 10-kA residual voltage stress of not less than $0,97 \times (U_{10 \text{ kA per mm of MO resistor length}})_{\text{max}}$, where $(U_{10 \text{ kA per mm of MO resistor length}})_{\text{max}}$ is the highest 10-kA residual voltage stress specified by the manufacturer for any length of the type of MO resistors used in the arrester. If only samples of lower 10-kA residual voltage stress are available, the required transferred charge shall be increased for the test by the factor
- $$(U_{10 \text{ kA per mm of MO resistor length}})_{\text{max}} / (U_{10 \text{ kA per mm of MO resistor length}})_{\text{actual}}$$
- e) The continuous operating voltage applied in tests involving thermal recovery shall fulfil the following requirement: The ratio of the continuous operating voltage to the rated voltage of the section shall be not less than the maximum ratio claimed for the arrester type.

7.3.2 Arrester section requirements

7.3.2.1 Thermally prorated section

The arrester section for thermal recovery tests shall thermally represent the arrester being modelled. Thermal equivalence shall be verified according to the procedure specified in Annex B.

The rated voltage of the prorated section shall be at least 3 kV.

In order to achieve thermal equivalence it may be necessary to introduce components that are usually not part of the design. It has to be assured that these measures do not affect the dielectric strength of the sample during energy or charge injection.

A thermally prorated section may also be a real arrester or arrester unit of the design.

In case of designs with two or more MO columns in parallel the thermally prorated section shall contain the same number of parallel columns as the actual arrester.

Upon agreement between manufacturer and user the thermally prorated section of a multi-column design arrester may contain only one single column if thermal equivalence is achieved.

For GIS arresters of multi-column design the thermally prorated section may contain only one single column if thermal equivalence is achieved.

No further requirements apply, especially on the design of the prorated section. Therefore, the thermally prorated section need not be a sliced portion of the arrester and need not contain only the same material as in the arrester. It may have a design different to that of the modelled arrester, as long as thermal equivalence and sufficient dielectric strength for the energy and charge injection, respectively, are assured.

7.3.2.2 Dielectrically prorated section

The arrester section for internal dielectric strength tests shall represent a sliced portion of the arrester being modelled, including the MO resistors, the housing and the supporting structure.

The rated voltage shall be at least 3 kV.

The section shall meet the following requirements: it shall be an exact copy of the real arrester with regard to diameters, materials etc. The mechanically supporting structure shall be included. Elements that are only located at distributed positions in the arrester being modelled, such as distance holders and spacers, shall be present in the model. The active part shall have the same surrounding medium as in the real arrester.

A dielectrically prorated section may also be a real arrester or arrester unit of the design.

An exact drawing of the dielectric model shall be published in the test report.

7.3.2.3 Section for residual voltage tests

The arrester section for the residual voltage tests shall be a complete arrester unit, a stack of series connected MO resistors or an individual MO resistor in still air. For multi-column arresters the section may be made of the actual number of MO resistors or resistor columns in parallel or of only one MO resistor or resistor column, respectively.

7.3.2.4 Section for the test to verify the repetitive charge transfer rating, Q_{rs}

The arrester section for the test to verify the repetitive charge transfer rating, Q_{rs} , shall be an individual MO resistor either in still air or in the actual surrounding medium of the design. The choice is at the discretion of the manufacturer.

8 Type tests (design tests)

8.1 General

Type tests defined in this clause apply to porcelain-housed arresters. The tests also apply to other types of arrester (polymer-housed, GIS, dead-front and separable, and liquid-immersed) unless otherwise noted in 10.8 for polymer-housed arresters, 11.8 for GIS arresters, 12.8 for dead-front and separable arresters, or 13.8 for liquid-immersed arresters.

Type tests shall be made as indicated in Table 3.

Table 3 – Arrester type tests

Arrester class	Station	Station	Distribution
Nominal discharge current	20 kA 10 kA	20 kA 10 kA	10 kA 5 kA 2,5 kA
Typical U_s (kV), rms value	> 245	≤ 245	≤ 52
1 Insulation withstand tests on the arrester housing			
a) Lightning impulse	8.2.6	8.2.6	8.2.6
b) Switching impulse	8.2.7	Not required	Not required
c) Power-frequency	Not required	8.2.8	8.2.8
2 Residual voltage test			
a) Steep current	8.3.2	8.3.2	8.3.2
b) Lightning impulse	8.3.3	8.3.3	8.3.3
c) Switching impulse	8.3.4	8.3.4	Not required
3 Test to verify long term stability under continuous operating voltage	8.4	8.4	8.4
4 Repetitive charge transfer withstand	8.5	8.5	8.5
5 Heat dissipation behaviour verification of test sample	8.6	8.6	8.6
6 Operating duty test	8.7	8.7	8.7
7 Power-frequency voltage versus time	8.8	8.8	8.8
8 Arrester disconnecter/fault indicator (when fitted)	8.9	8.9	8.9
9 Short-circuit tests	8.10	8.10	8.10
10 Bending moment	8.11	8.11	8.11
11 Environmental tests	8.12	8.12	8.12
12 Seal leak rate	8.13	8.13	8.13
13 Radio interference voltage (RIV)	8.14	8.14	Not required
14 Test to verify the dielectric withstand of the internal components of an arrester	8.15	8.15	8.15
15 Test of internal grading components	8.16	8.16	8.16
16 Polluted housing test	Annex C	Annex C	Annex C
Numbers in rows 1-16 refer to clauses and subclauses in this standard.			
NOTE Type tests for other types of arresters (polymer-housed, GIS, dead-front and separable, and liquid-immersed) are specified in 10.8, 11.8, 12.8 and 13.8.			

The required numbers of samples and their conditions are specified in the individual clauses. Arresters that differ only in methods of mounting or arrangement of the supporting structure, and which are otherwise based on the same components and similar construction resulting in the same performance characteristics including their heat dissipation conditions and internal atmosphere, are considered to be of the same design.

8.2 Insulation withstand tests

8.2.1 General

The voltage withstand tests demonstrate the voltage withstand capability of the external insulation of the arrester housing. For other designs the test has to be agreed upon between the manufacturer and the user.

The tests shall be performed in the conditions and with the test voltages specified below. The outside surface of insulating parts shall be carefully cleaned and the internal parts removed or rendered inoperative to permit these tests.

If any of the conditions relating dry arc distance to test voltage, as described in 8.2.6, 8.2.7 or 8.2.8, is fulfilled then the relevant test specified in 8.2.6, 8.2.7 or 8.2.8 need not be performed, since, under these conditions, the insulation withstand voltage of the arrester will inherently meet the minimum requirement.

8.2.2 Tests on individual unit housings

For arresters intended for use on systems of $U_s \leq 245$ kV, lightning impulse voltage tests according to 8.2.6 and power-frequency voltage tests according to 8.2.8 shall be performed on individual unit housings.

The applicable tests shall be run on the longest arrester housing. If this does not represent the highest specific voltage stress per unit length, additional tests shall be performed on the unit housing having the highest specific voltage stress. For the test, the MO resistors shall be removed from the housing or replaced by insulators.

8.2.3 Tests on complete arrester assemblies

For arresters intended for use on systems of $U_s > 245$ kV, lightning impulse voltage tests according to 8.2.6 and switching impulse voltage tests according to 8.2.7 shall be performed on complete arrester assemblies.

The switching impulse tests for arresters intended for outdoor use shall be performed under wet conditions with the arrester placed on a pedestal. Details of the pedestal used shall be stated in the test report. The switching impulse tests for arresters intended for indoor use shall be performed under dry conditions.

The housing shall be equipped with the complete external grading system. The MO resistors shall be replaced by resistors, capacitors or higher resistance MO resistors to obtain, approximately, the same voltage grading of the arrester during high current discharges as would be given by the actual MO resistors used in the arrester. When using MO resistors, the resistors shall have a protection characteristic that will result in at least 1 A peak during the insulation withstand test.

NOTE The use of higher resistance MO resistors is an alternative for lightning and switching impulse voltage tests but not for the power-frequency voltage test because of the inability of the arrester to survive for 1 min at the applied power frequency voltage for current flow of 1 A.

8.2.4 Ambient air conditions during tests

The voltage to be applied during a withstand test is determined by multiplying the specified withstand voltage by the correction factor taking into account density and humidity (see IEC 60060-1).

Humidity correction shall not be applied for wet tests.

8.2.5 Wet test procedure

The external insulation of outdoor arresters shall be subjected to wet withstand tests under the test procedure given in IEC 60060-1.

8.2.6 Lightning impulse voltage test

The arrester shall be subjected to a standard lightning impulse voltage dry test according to IEC 60060-1. The test voltage shall be at least 1,3 times the maximum residual voltage of the arrester at nominal discharge current.

NOTE The 1,3 factor is obtained from $1,15 \cdot e^{1000/8150}$, which reflects a 15 % coordination factor to take into account discharge currents higher than nominal and the statistical nature of the withstand voltage of the insulation, and a 13 % margin to account for variation in air pressure from sea level up to normal service altitudes not exceeding 1 000 m.

Fifteen consecutive impulses at the test voltage value shall be applied for each polarity. The arrester shall be considered to have passed the test if no internal disruptive discharges occur and if the number of the external disruptive discharges does not exceed two in each series of 15 impulses. The test voltage shall be equal to the lightning impulse protection level of the arrester multiplied by 1,3.

If the dry arcing distance or the sum of the partial dry arcing distances in m is larger than the test voltage in kV divided by 500 kV/m, this test is not required.

8.2.7 Switching impulse voltage test

Station class arresters according to Table 1 intended for use on systems of $U_s > 245$ kV shall be subjected to a standard switching impulse voltage test according to IEC 60060-1. Arresters for outdoor use shall be tested in wet conditions, arresters for indoor use in dry conditions. The test voltage shall be at least the maximum switching impulse residual voltage of the arresters multiplied by $1,1 \times e^{m \times 1000/8150}$ where

- for arresters intended for use on systems of $U_s \leq 800$ kV, $m = 1$
- for arresters intended for use on systems of $U_s > 800$ kV, m is taken from IEC 60071-2:1996, Figure 9, phase-to-earth insulation, where the value on the abscissa shall be 1,1 times the switching impulse protection level of the arrester

NOTE 1 The factor $1,1 \times e^{m \times 1000/8150}$ reflects a 10 % coordination factor to take into account discharge currents higher than normal and the statistical nature of the withstand voltage of the insulation, and a 13 % margin to account for variation in air pressure from sea level up to normal service altitudes not exceeding 1 000 m

When the insulation requirements of arresters intended for use on systems of $U_s > 800$ kV calculated from the above are still higher than selected for the protected equipment the same insulation levels should apply also for the arresters.

Fifteen consecutive impulses at the test voltage value shall be applied for each polarity. The arrester shall be considered to have passed the test if no internal disruptive discharges occur and if the number of the external disruptive discharges does not exceed two in each series of 15 impulses.

If the dry arcing distance or the sum of the partial dry arcing distances is larger than given by the equation $d = 2,2 \times [e^{(U/1069)} - 1]$, where d is the distance in m and U is the test voltage in kV, this test is not required.

NOTE 2 The equation is derived from formula G.3 of IEC 60071-2:1996, where U_{50} is given as $k \times 1080 \times \ln(0,46 \times d + 1)$, k is the gap factor and d is the distance. For the purpose of this standard, the gap factor k is assumed to be equal to 1,1, and two standard deviations of 0,05 each are taken into account to achieve the withstand voltage.

8.2.8 Power-frequency voltage test

The housings of arresters intended for outdoor use shall be tested in wet conditions, and housings of arresters intended for indoor use shall be tested in dry conditions.

Housings of distribution class arresters according to Table 1 shall withstand a power-frequency voltage with a peak value equal to the lightning impulse protection level multiplied by 0,88 for a duration of 1 min.

NOTE 1 The factor of 0,88 takes into account a safety margin of 1,15 for lightning impulse currents higher than nominal discharge current, an altitude correction factor of 1,13 for 1 000 m installation altitude, a factor 0,8 as a typical ratio between switching and lightning impulse protection level and a test conversion factor of $0,6 \times \sqrt{2}$ for conversion from switching impulse voltage to peak value of power-frequency voltage according to Table 2 of IEC 60071-2:1996.

Housings of station class arresters according to Table 1 intended for application on systems of $U_s \leq 245$ kV shall withstand a power-frequency voltage with a peak value equal to the switching impulse protection level multiplied by 1,06 for a duration of 1 min.

NOTE 2 The factor of 1,06 takes into account a safety margin of 1,1 for higher switching impulse currents, an altitude correction factor of 1,13 for 1 000 m installation altitude, and a test conversion factor of $0,6 \times \sqrt{2}$ according to Table 2 of IEC 60071-2:1996.

If the dry arcing distance or the sum of the partial dry arcing distances is larger than given by the equation $d = [1,82 \times (e^{(U/859)} - 1)]^{0,833}$, where d is the distance in m and U is the peak value of the power-frequency test voltage in kV, this test is not required.

NOTE 3 The equation is derived from formula G.1 of IEC 60071-2:1996, where the peak value of U_{50} is given as $750 \times \sqrt{2} \times \ln(1 + 0,55 \times d^{1,2})$, d being the distance. Following the recommendations given in IEC 60071-2, for the purpose of this standard the gap factor k is assumed to be equal to 1, the withstand voltage is assumed to be 90 % of U_{50} , and a 10 % reduction in U_{50} is assumed for wet conditions compared to dry.

8.3 Residual voltage tests

8.3.1 General

The purpose of the residual voltage type test is to obtain the data necessary to derive the maximum residual voltage as explained in 6.3. It includes the calculation of the ratio between voltages at specified impulse currents and the voltage level checked in routine tests. The latter voltage can be either the reference voltage or the residual voltage at a suitable lightning current impulse in the range 0,01 to 2 times the nominal discharge current depending on the manufacturer's choice of routine test procedure.

The maximum residual voltage at a lightning current impulse used for routine tests shall be specified and published in the manufacturer's data. Maximum residual voltages of the design for all specified currents and wave-shapes are obtained by multiplying the measured residual voltages of the test sections by the ratio of the declared maximum residual voltage at the routine test current to the measured residual voltage for the section at the same current.

For arresters with rated voltages below 36 kV (see item b) of 9.1), the manufacturer may choose to check only the reference voltage by routine test. The maximum reference voltage shall then be specified. The measured residual voltages of the test sections are multiplied by the ratio of this maximum arrester reference voltage to the measured reference voltage of the test sections to obtain maximum residual voltages for all specified currents and wave shapes.

All residual voltage tests shall be made on the same three samples of complete arresters or arrester sections. The time between discharges shall be sufficient to permit the samples to return to approximately ambient temperature. For multi-column arresters the test may be performed on sections made of only one column; the residual voltages are then measured for currents obtained from the total currents in the complete arrester divided by the number of columns.

8.3.2 Steep current impulse residual voltage test

One steep current impulse with a peak value equal to the nominal discharge current of the arrester ± 5 % shall be applied to each of the three samples. The peak value and the impulse shape of the voltage appearing across the three samples shall be recorded and, if necessary,

corrected for inductive effects of the voltage measuring circuit as well as the geometry of the test sample and the test circuit.

The following procedure shall be used to determine if an inductive correction is required:

- A steep current impulse as described above shall be applied to a non-ferrous metal block having the same dimensions as the MO resistor samples being tested. The peak value and the shape of the voltage appearing across the metal block shall be recorded.
- If the peak voltage on the metal block is less than 2 % of the peak voltage of the MO resistor samples, no inductive correction to the MO resistor measurements is required.
- If the peak voltage on the metal block is between 2 % and 20 % of the peak voltage on the MO resistor sample, then the impulse shape of the metal block voltage shall be subtracted from the impulse shape of each of the MO resistor voltages and the peak values of the resulting impulse shapes shall be recorded as the corrected MO resistor voltages.
- If the peak voltage on the metal block is greater than 20 % of the peak voltage on the MO resistor samples, then the test circuit and the voltage measuring circuit shall be improved and the test shall be repeated.

NOTE 1 A possible way to achieve identical current wave shapes during all measurements is to perform them with both the test sample and the metal block in series in the test circuit. Only their positions relative to each other need to be interchanged for measuring the voltage drop on the metal block or on the test sample.

The highest of the three measured residual voltages, corrected if necessary as indicated above, and multiplied by the scale factor (see 7.3) is defined as the steep current protection level of the arrester excluding the inductive voltage contribution of the arrester.

In addition, the maximum steep current residual voltage including inductive voltage contribution has to be calculated as specified in 6.3.

NOTE 2 Connecting leads to connect the arrester to the power system will introduce additional inductive voltage drop for steep current impulse currents.

8.3.3 Lightning impulse residual voltage test

One lightning current impulse shall be applied to each of the three samples for each of the following three peak values of approximately 0,5, 1 and 2 times the nominal discharge current of the arrester. Virtual front time shall be within 7 μ s to 9 μ s while the half-value time (which is not critical) may have any tolerance. The residual voltages are determined in accordance with 6.3. The maximum values of the determined residual voltages shall be drawn in a residual voltage versus discharge current curve. The residual voltage read on such a curve corresponding to the nominal discharge current is defined as the lightning impulse protection level of the arrester.

If a complete arrester routine test cannot be carried out at one of the above currents, then additional type tests shall be carried out at a current in the range of 0,01 to 0,25 times nominal discharge current for comparison to the complete arrester.

8.3.4 Switching impulse residual voltage test

One switching current impulse shall be applied to each of the three samples with peak values according to Table 1 with a tolerance of ± 5 %. The residual voltages are determined in accordance with 6.3. The highest of these three voltages is defined as the switching impulse residual voltage of the arrester.

8.4 Test to verify long term stability under continuous operating voltage

8.4.1 General

Typically, under normal operation, a surge arrester is stressed at a voltage below its reference voltage, U_{ref} . The test to verify long term stability for such cases is given in 8.4.2.

However, for certain arrester designs the normal operating voltage may be at or even above U_{ref} , in which case it may not be possible to perform a test in the same manner, and an alternative test for this case is given in 8.4.3.

8.4.2 MO resistor elements stressed below U_{ref}

8.4.2.1 Procedure

This test shall be performed on three new samples of MO resistors with a reference voltage fulfilling the requirements of 7.3. The power-frequency voltage shall fulfil the requirements stated for the operating duty test (see 8.7.1).

All material (solid or liquid) in direct contact with the MO resistors in the arrester shall be present during the ageing test with the same design as used in the complete arrester.

During the test, the MO resistors shall be placed in a temperature-controlled oven in the same surrounding medium as used in the arrester. The volume of the oven chamber shall be at least twice the volume of the MO resistor and the density of the medium in the chamber shall not be less than the density of the medium in the arrester.

NOTE 1 The medium surrounding the MO resistor within the arrester may be subject to a modification during the normal life of the arrester due to internal partial discharges. Possible change of the medium surrounding the MO resistor in the field can significantly increase the power losses.

A suitable test procedure taking into account such modifications is under consideration. During this time an alternative procedure consists in performing the test in N_2 or SF_6 (for GIS-arresters) with a low oxygen concentration (less than 0,1 % in volume). This ensures that even in the total absence of oxygen, the arrester will not age.

If the manufacturer can prove that the test carried out in the open air is equivalent to that carried out in the actual medium, the ageing procedure can be carried out in the open air.

The MO resistors shall be heated to $115\text{ °C} \pm 4\text{ K}$ and the MO resistor power losses P_{start} shall be measured at the corrected maximum continuous operating voltage of U_{ct} (see below) $3\text{ h} \pm 15\text{ min}$ after the voltage application. The samples shall be maintained at this voltage for 1 000 h, during which the oven temperature shall be controlled to keep the surface temperature of the MO resistor at $115\text{ °C} \pm 4\text{ K}$.

The MO resistor power losses shall be measured at U_{ct} at intervals of not more than 100 h after the first measurement, and a final measurement, P_{end} , shall be made after $1\,000^{+100}_0$ h of ageing. The lowest power losses attained during the test period shall be designated as P_{min} (see Figure 1).

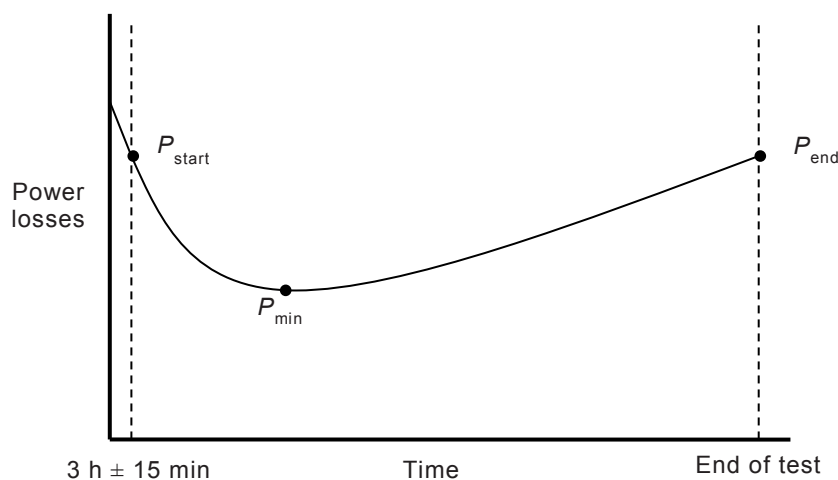

IEC 1957/14

Figure 1 – Illustration of power losses versus time during long term stability test

Accidental intermediate de-energizing of the test samples, not exceeding a total duration of 24 h during the test period is permissible. The interruption will not be counted in the duration of the test. The final measurement should be performed after not less than 100 h of continuous energizing. Within the temperature range allowed, all measurements shall be made at the same temperature ± 1 K.

The relevant voltage for this procedure is the corrected maximum continuous operating voltage (U_{ct}), which the MO resistors support in the arrester including voltage unbalance effects. This voltage shall be determined by voltage distribution measurements or computations.

NOTE 2 Information on procedures for voltage distribution calculations is given in Annex F.

For arresters with a length H of less than 1 m, except for arresters with conductive, grounded enclosures such as GIS-arresters, liquid-immersed, dead-front or screened/shielded separable arresters, the voltage may be determined from the following formula:

$$U_{ct} = U_c (1 + 0,15 H)$$

where

H is the total length of the arrester (m).

8.4.2.2 Evaluation

The test shall be considered passed if, for all three MO resistors, the following criteria are met:

any increase of power losses from P_{min} is not greater than 1,3 times P_{min} during the remaining test period

all measurements of power losses throughout the ageing period, including the final measurement, P_{end} , is not greater than 1,1 times P_{start} .

8.4.3 Test procedure for MO resistor elements stressed at or above U_{ref}

8.4.3.1 General

If U_{ct} is close to or above the reference voltage, it may not be possible to perform an accelerated ageing test at U_{ct} , due to the extreme voltage dependence for the power losses and stability of available voltage source. If $U_{ct} \geq 0,95 \times U_{ref}$ and if it is not possible to perform

an accelerated ageing test according to 8.4.2.1, this alternative test procedure shall apply and replaces 8.4.2.1 and 8.4.2.2

The steps required for the procedure are as follows:

- 1) Calculate power losses, P_{ct} , for the highest stressed MO resistor in the arrester (at $T_a = 40\text{ °C}$ and $U = U_C$).
- 2) Determine the steady-state temperature, T_{st} , for the highest stressed part of the arrester by using one of the three alternative procedures of 8.4.3.2.
- 3) At a voltage U_{ct} , determine the ratio, k_x , of power loss at 115 °C to power loss at T_{st} for the type of MO resistors used.
- 4) Perform an accelerated ageing test at constant power losses of $k_x \times P_{ct}$.
- 5) Interrupt the test for a short time and take measurements of power losses at 100 h intervals.
- 6) If $T_{st} > 60\text{ °C}$, increase test temperature or test time.
- 7) Evaluate the power losses of step 5) according to 8.4.3.4

8.4.3.2 Determination of test parameters

Calculate the power losses, P_{ct} , at the maximum ambient temperature of 40 °C with the arrester energized at U_C , for the highest voltage stressed MO resistor according to Annex F including the effect of the resistive current.

NOTE 1 For dead-front and liquid-immersed arresters, 65 °C and 95 °C , respectively, apply as maximum ambient temperatures.

Select one of the three following test procedures to determine the steady-state temperature, T_{st} , of the most stressed part of the arrester at maximum ambient temperature.

NOTE 2 The test procedures are considered to be conservative in increasing order from 1 to 3.

- 1) At an ambient temperature of $25\text{ °C} \pm 10\text{ K}$, energize the complete arrester at the claimed U_C until steady-state temperature conditions have been attained. The temperature shall be measured on MO resistors at five points as evenly spaced as possible over the most highly stressed 20 % portion of the length of each column of the arrester. If this 20 % portion contains less than five MO resistors, the number of measuring points may be limited to one point on each MO resistor. The average temperature rise above ambient of the MO resistor elements shall be added to the maximum ambient temperature to obtain the temperature T_{st} .
- 2) At the maximum ambient temperature, energize a thermally pro-rated section representative for the arrester type at a voltage level, which results in the same power losses per MO resistor as determined above. Keep the power losses constant by adjusting the voltage if necessary. Measure the temperature of the MO resistors in steady-state condition and calculate the average steady-state temperature, which is set equal to T_{st} .
- 3) At an ambient temperature of $25\text{ °C} \pm 10\text{ K}$, energize a thermally pro-rated section representative for the arrester type at a voltage level which results in the same power losses per MO resistor as determined above. Keep the power losses constant by adjusting the voltage if necessary. Measure the temperature of the MO resistors in steady-state condition and calculate the average steady-state temperature rise, ΔT_{st} , above ambient. Determine the temperature T_{st} , by adding ΔT_{st} to the maximum ambient temperature.

The thermally prorated section shall be in accordance with 7.3.2.1.

At a voltage U_{ct} , determine the ratio, k_x , of power losses at 115 °C to power losses at T_{st} for the type of MO resistors used. For this test the voltage source shall fulfil the requirements according to 8.7.1.

8.4.3.3 Procedure

The test shall be performed on three typical samples of MO resistors with a reference voltage fulfilling the requirements of 7.3. Three MO resistor samples shall be subjected to constant power losses equal to $k_x \times P_{ct}$ (tolerance $^{+30}_0$ %) for 1 000 h. During the test, the temperature shall be controlled to keep the surface temperature of the MO resistor at the required test temperature $T_t \pm 4$ K. The applied test voltage at the start of the test shall be not less than $0,95 \times U_{ct}$.

If the temperature, T_{st} , is equal to or below 60 °C, T_t shall be 115 °C. If T_{st} is above 60 °C, either the test temperature or the testing time shall be increased as follows.

Increase of the test temperature

$$T_t = 115 + (T_{st} - T_{a,max} - \Delta T_n)$$

where

T_t is the test temperature in °C;

T_{st} is the steady-state temperature of the MO resistors in °C;

$T_{a,max}$ is the maximum ambient temperature in °C;

$\Delta T_n = 20$ K.

NOTE 1 For liquid-immersed arresters $\Delta T_n = 25$ K, which results from the requirement that the operating duty test starting temperature for these arresters (120 °C) is 25 K above the maximum ambient temperature (95 °C), while for other arresters the difference between the operating duty test starting temperature and the maximum ambient temperature is 20 K.

Increase of the testing time

$$t = t_0 \times 2,5^{\Delta T/10}$$

where

t is the testing time in h;

$t_0 = 1\ 000$ h;

ΔT is the temperature above 60 °C.

NOTE 2 For dead-front and liquid-immersed arresters, t_0 is 2 000 h and 7 000 h, respectively, and ΔT is the temperature above 85 °C and 120 °C, respectively.

One to two hours after the voltage application, the voltage is adjusted to a voltage in the range $0,95 \times U_{ct}$ to U_{ct} and the power losses, P_{start} , are measured. This measurement is repeated once in approximately every 100 h after the first measurement, and at the final testing time $^{+100}_0$ h of ageing the final power losses, P_{end} , are measured.

All material (solid or liquid) in direct contact with the MO resistors in the arrester shall be present during the ageing test with the same design as used in the complete arrester.

During the test, the MO resistors shall be placed in a temperature-controlled oven in the same surrounding medium as used in the arrester. The volume of the oven chamber shall be at least twice the volume of the MO resistor and the density of the medium in the chamber shall not be less than the density of the medium in the arrester.

NOTE 3 The medium surrounding the MO resistor within the arrester may be subject to a modification during the normal life of the arrester due to internal partial discharges. Possible change of the medium surrounding the MO resistor in the field can significantly increase the power losses.

A suitable test procedure taking into account such modifications is under consideration. During this time an alternative procedure consists in performing the test in N_2 or SF_6 (for GIS-arresters) with a low oxygen

concentration (less than 0,1 % in volume). This ensures that even in the total absence of oxygen, the arrester will not age.

If the manufacturer can prove that the test carried out in the open air is equivalent to that carried out in the actual medium, the ageing procedure can be carried out in the open air.

Accidental intermediate de-energizing of the test samples, not exceeding a total duration of 24 h during the test period is permissible. The interruption will not be counted in the duration of the test. The final measurement should be performed after not less than 100 h of continuous energizing. Within the temperature range allowed, all measurements shall be made at the same temperature ± 1 K.

8.4.3.4 Evaluation

The test shall be considered passed if, for all three MO resistors, the following criteria are met:

any increase of power losses from P_{\min} is not greater than 1,3 times P_{\min} during the remaining test period

all measurements of power losses throughout the ageing period, including the final measurement, P_{end} , is not greater than 1,1 times P_{start} .

8.5 Test to verify the repetitive charge transfer rating, Q_{rs}

8.5.1 General

The purpose of this test is to verify the repetitive charge transfer rating, Q_{rs} , of an arrester.

Repetitive charge transfer capability is specified as an impulse current stress that can be withstood by the MO resistors of an arrester twenty times without mechanical or unacceptable electrical damage. One impulse current stress is considered to represent a charge transfer event that may occur under real system conditions.

The repetitive charge transfer rating is related to a certain very low failure probability and is thus not a deterministic but a statistical value. The test is performed on individual MO resistors at a charge value in the range 1,1 to 1,2 times the rated value selected from the list in 8.5.4. By this approach it is assumed that the performance of the individual MO resistors can also be assigned to a full arrester built from these MO resistors, based on the test requirements and the chosen statistical approach.

Charge has been chosen as a test basis for the purpose of better comparison between different makes of MO resistors.

For this test long-duration impulse currents or unipolar sine half-wave current impulses of similar time durations shall be applied. Only for MO resistors that are intended for use in distribution class arresters and in NGLA, lightning impulse currents 8/20 μs or lightning impulse discharges as per 3.32 may be used. The choice is at the discretion of the manufacturer.

An arrester shall be assigned a Q_{rs} value from the list given in 8.5.4.

A first test sequence shall be performed on 10 samples of MO resistors selected according to 7.3.1 d). If not more than one MO resistor fails, the entire test is passed. If two MO resistors fail, a second sequence identical to the first shall be performed on an additional 10 samples. The entire test shall then be passed if there is no failure of an MO resistor during this second sequence. If more than two MO resistors fail in the first test sequence or any MO resistor fails in the second test sequence, the entire test is failed.

8.5.2 Test procedure

Figure 2 gives an overview of the test procedure.

Initial tests
<ul style="list-style-type: none"> • Residual voltage test at nominal discharge current • Reference voltage test at specified reference current
Application of 1,1 times Q_{rs}
<ul style="list-style-type: none"> • 1st sequence: 20 impulses per sample (10 samples) • if not more than one sample failure during 1st sequence: test passed • if not more than two sample failures during 1st sequence: conduct 2nd sequence with 10 samples, 20 impulses per sample • if more than two sample failures in 1st sequence or any sample failure in 2nd sequence: test failed
Test evaluation: check for
<ul style="list-style-type: none"> • no mechanical damage at visual inspection • change of reference voltage within $\pm 5\%$ • change of residual voltage at nominal discharge current within $\pm 5\%$ • withstand capability to one 8/20 current impulse of at least 0,5 kA/cm² peak current density or 2 times I_n, whichever is lower

Figure 2 – Test procedure to verify the repetitive charge transfer rating, Q_{rs}

Ten test samples shall be tested in the first sequence. Depending on the results, it may be necessary to test an additional ten samples in a second sequence.

The samples shall fulfil the requirements in 7.3.

The following procedure shall be followed:

Each sample shall be subjected to a residual voltage test at nominal discharge current and a reference voltage test at specified reference current before and after the test. For MO resistors in multi-column arresters the nominal discharge current applied in the test is the highest nominal discharge current used for the type of MO resistors in any design.

Each sample shall be subjected to twenty current impulses administered in ten groups of two impulses, with time between impulses within a group of 50 s to 60 s and time between groups sufficient for cooling to ambient temperature.

The wave shape and duration of the current impulses shall be as follows:

- for arresters not intended for application on overhead transmission or distribution lines (i.e. intended for use in stations): long-duration (rectangular) impulses of 2 ms to 4 ms virtual total duration or unipolar sine half-wave impulses of 2 ms to 4 ms total duration;
- for NGLA: lightning impulse discharges according to Annex H;
- for distribution class arresters: 8/20 lightning impulses.

The charge content of each impulse shall be as follows:

- for single-column arresters: at least equal to the claimed repetitive charge transfer rating (selected from the list given in 8.5.4) multiplied by 1,1;
- for multi-column arresters: at least equal to the claimed repetitive charge transfer rating (selected from the list given in 8.5.4) multiplied by 1,1, then divided by the number of columns, and then multiplied by the current sharing factor β_g (see item c) of 7.3).

NOTE 1 The requirement of testing at least 1,1 times the rated charge values is considered to give sufficient confidence that the performance of the individual MO resistors can also be assigned to complete arresters built from this type of MO resistors.

NOTE 2 If MO resistors tested with charge values for single-column arresters are used in a multi-column arrester and no new test is performed the repetitive charge transfer rating for the complete multi-column arrester is the next lower or equal value (in the list shown in 8.5.4) to the repetitive charge transfer rating of the MO resistors times the number of columns and divided by the current sharing factor.

8.5.3 Test evaluation

The full test shall be considered passed if either

- not more than one sampled failed during the first sequence, or
- not more than two samples failed during two sequences.

Otherwise, the test is considered as failed and a lower charge level, Q_{rs} , from the list shown in 8.5.4 shall be selected, and the test shall be repeated for this lower charge level following the procedure given in 8.5.2.

NOTE 1 If only one failure occurs during the first sequence and this happens, in the worst case, at the very first impulse application, 180 impulses without failure will have been applied at the end, giving a failure probability of max. $1/181 = 0,0056$ or 0,56 % for the complete test. If two failures occur during the first sequence and this happens, again as a worst case, at the very first applications on two of the samples, 360 impulses without failure will have been applied at the end of both sequences, giving again a failure probability of max. $2/362 = 0,0056$ or 0,56 % for the complete test.

Each individual sample shall be considered to have withstood the complete series of impulses if all the following criteria are met:

- there is no indication of mechanical damage (puncture, flashover or cracking);
- any change of the reference voltage before and after the test, measured at the same temperature ± 3 K, is within ± 5 %;
- any change of the residual voltage at nominal discharge current before and after the test is within ± 5 %;
- a final application of a current impulse 8/20 μ s of an amplitude resulting in a current density of at least 0,5 kA/cm² or in 2 times I_n , whichever is lower, is passed without mechanical damage.

NOTE 2 Burning or arcing damage to the metallization is not considered a mechanical damage if all other pass criteria are met.

8.5.4 Rated values of repetitive charge transfer rating, Q_{rs}

The repetitive charge transfer rating values shall be taken from the following list:

- from 0,1 C to 1,2 C in steps of 0,1 C
- from 1,2 C to 4,4 C in steps of 0,4 C
- from 4,4 C up to 10,0 C in steps of 0,8 C
- from 10 C to 20 C in steps of 2 C
- from 20 C upward in steps of 4 C

NOTE The following factors to calculate corresponding impulse current amplitudes from the charge values are given for guidance:

- Long-duration current, 2 ms: $i / A \approx 500 \times Q_{rs} / C$
- Long-duration current, 4 ms: $i / A \approx 250 \times Q_{rs} / C$
- Unipolar sine half-wave, 2 ms: $i / A \approx 786 \times Q_{rs} / C$
- Unipolar sine half-wave, 4 ms: $i / A \approx 393 \times Q_{rs} / C$
- Lightning current impulse 8/20: $i / kA \approx 62 \times Q_{rs} / C$
- Lightning impulse discharge according to 3.32: $i / kA \approx 8 \times Q_{rs} / C$

The resulting current amplitudes are informative and are approximate values, calculated under the assumption of an ideally rectangular impulse current shape in case of the long-duration current impulses, of an ideal lightning current impulse 8/20 μ s and of an ideally sinusoidal half-wave current of 200 μ s base time in case of the lightning

impulse discharges. As an actual current shape will deviate from the ideal shape the actual amplitudes necessary to reach the rated charge values might differ from the values listed here.

8.6 Heat dissipation behaviour of test sample

8.6.1 General

In the operating duty test (8.7) and the power frequency voltage-versus-time test (8.8), the behaviour of the test sample is to a great extent dependent on the ability of the sample to dissipate heat, i.e. to cool down after being stressed by a discharge.

Consequently, the test samples shall have a transient and a steady-state heat dissipation capability and heat capacity equivalent to the complete arrester if correct information is to be obtained from the test. For the same ambient conditions the MO resistors in the sample and in the complete arrester should in principle reach the same temperature when subjected to the same voltage stress.

A test shall be performed to demonstrate this equivalency (see 8.6.3).

8.6.2 Arrester section requirements

The requirements are specified in 7.3.2.1.

8.6.3 Procedure to verify thermal equivalency between complete arrester and arrester section

Thermal equivalency between the complete arrester and the arrester section shall be demonstrated following the procedure of Annex B.

8.7 Operating duty test

8.7.1 General

The purpose of this test is to verify the arrester's ability to thermally recover after injection of the rated thermal energy, W_{th} , or transfer of the rated thermal charge, Q_{th} , respectively, under applied temporary overvoltage and following continuous operating voltage conditions. The test shall be performed on three samples.

NOTE 1 Though thermal stability has basically no statistical character, three test samples are specified. This compensates for statistical factors such as incorrect voltage adjustment, variability in the power loss characteristic, tolerance during energy injection etc.

The samples shall fulfil the requirements of 7.3.

Each design of arrester shall be assigned either a thermal energy rating, W_{th} , or a thermal charge transfer rating, Q_{th} , depending on its application:

- for station class arresters: W_{th} from the list in 8.7.3
- for distribution class arresters: Q_{th} from Table 5

NOTE 2 The requirements on NGLA are kept unchanged at the moment. Thus energy values, charge values and the test procedure according to Annex H apply.

The characterization and conditioning part of the test (8.7.2.2) may be performed at an ambient temperature of $20\text{ °C} \pm 15\text{ K}$ on the MO resistors in still air or on the dielectrically prorated section according to 7.3.2.2.

The thermal recovery part of this test (8.7.2.3) shall be performed on thermally prorated sections according to 7.3.2.1. It shall be demonstrated by adequate methods that the start temperature requirement is fulfilled at the beginning of the thermal recovery part of the test.

The relative uncertainty between measurements of the applied voltage shall not be more than ± 1 %. This may be achieved by any suitable means, e.g. by using identical measuring setups or by calibration of all used measuring setups to ± 1 %. The peak value of the voltage shall not vary by more than 1 % from no-load to full-load condition. The ratio of peak voltage to r.m.s. value shall not deviate from $\sqrt{2}$ by more than 2 %. During the tests, the power frequency voltage shall not deviate from the specified values by more than ± 1 %.

8.7.2 Test procedure

8.7.2.1 General

Figure 3 gives an overview of the test procedure.

<p>Pre-tests</p> <ul style="list-style-type: none"> • Verification of thermal equivalence of the thermally prorated section • Determination of the start temperature for the thermal recovery part
<p>Initial tests for sample characterization</p> <ul style="list-style-type: none"> • Residual voltage test at nominal discharge current • Reference voltage test at specified reference current • Check for correct current sharing in case of multi-column arrester design
<p>Determination of continuous operating voltage and rated voltage, if necessary adjusted as per 7.3</p>
<p>Conditioning</p> <p>Station class arresters:</p> <ul style="list-style-type: none"> • Two high current impulses (as per Table 4) <p>Distribution class arresters:</p> <ul style="list-style-type: none"> • One high current impulse (as per Table 4)
<p>Hold for future use</p>
<p>Preheating to start temperature as per 8.7.2.3..</p>
<p>Station class arresters:</p> <ul style="list-style-type: none"> • Rated thermal energy injection, W_{th}, within three minutes by one or more long-duration current impulses or by unipolar sine half-wave current impulses or, in case of NGLA, by lightning impulse discharges according to 8.7.3 <p>Distribution class arresters:</p> <ul style="list-style-type: none"> • Rated thermal charge transfer, Q_{th}, within one minute by two lightning current impulses 8/20 μs according to 8.7.3
<p>Application of U_r for 10 s (within 100 ms after energy or charge injection)</p>
<p>Application of U_c for at least 30 min (until pass or fail is evident)</p>
<p>Test evaluation</p> <ul style="list-style-type: none"> • Thermal recovery • No physical damage • Change of residual voltage at nominal discharge current within $\pm 5\%$

Figure 3 – Test procedure to verify the thermal energy rating, W_{th} , and the thermal charge transfer rating, Q_{th} , respectively

For arresters intended for application on systems of $U_s \leq 800$ kV the start temperature, ϑ_{Start} , of the thermal recovery part of the test shall be $\vartheta_{Start} \pm 3$ K. For arresters intended for application on systems of $U_s > 800$ kV the start temperature shall be determined according to Annex I.

8.7.2.2 Characterization and conditioning

The following procedure shall be applied for characterization and conditioning:

Each sample shall be subjected to a residual voltage test at the nominal discharge current before and after the test and a reference voltage test at specified reference current only before the test. The reference voltage test is necessary to calculate the continuous operating

voltage and the rated voltage. For multi-column arresters the distribution of the current between the columns shall be measured at the impulse current for current distribution test (see item e) of 9.1). As an alternative, if the current sharing of the sample under impulse current stress is not directly measured, the injected energy shall be increased by the factor β_g (i.e. it is then assumed that $\beta_a = 1$). The highest current value shall not be higher than an upper limit specified by the manufacturer.

For the purpose of conditioning, the samples shall be subjected to high current impulses as specified in Table 4.

- a) Station class arresters: The samples shall be exposed to two high current impulses. The conditioning may be performed in the dielectrically prorated section, and the first high current impulse application may be considered the test to verify dielectric withstand of the internal components of an arrester (see 8.15) if all other requirements of 8.15 are also fulfilled. There shall be sufficient time between and after the impulses to allow for cooling to ambient temperature.
- b) Distribution class arresters: The samples shall be exposed to one high current impulse.

The impulses shall be of same polarity, and their polarity shall be the same as that of the current impulses for energy injection and charge transfer, respectively, in the thermal recovery part of the test.

After application of the high current impulses the samples shall be stored at room temperature. If the conditioning has been performed on the dielectrically prorated section the MO resistors shall be removed from the section before storage. The samples shall not subsequently be energized by any kind of voltage or current stress before the thermal recovery test is performed.

NOTE Heating the samples for longer time at very high temperatures, application of alternating voltage or application of impulse currents of opposite polarity might lead to recovery from possible electrical ageing effects and is therefore not permitted.

Table 4 – Requirements for high current impulses

Arrester classification	Peak current 4/10 kA
20 kA and 10 kA	100
5 kA	65
2,5 kA	25

The tolerances on the adjustment of the equipment shall be such that the measured values of the current impulses are within the following limits:

- a) from 90 % to 110 % of the specified peak value;
- b) from 3,5 μ s to 4,5 μ s for virtual front time;
- c) from 9 μ s to 11 μ s for virtual time to half-value on the tail;
- d) the peak value of any opposite polarity current wave shall be less than 20 % of the peak value of the current;
- e) small oscillations on the impulse are permissible provided their amplitude near the peak of the impulse is less than 5 % of the peak value. Under these conditions, for the purpose of measurement, a mean curve shall be accepted for determination of the peak value.

8.7.2.3 Thermal recovery test

The following procedure shall be applied for the thermal recovery part of the test:

The complete test samples shall be preheated to a temperature of at least the start temperature, ϑ_{Start} , as follows:

- for arresters for $U_s \leq 800$ kV: ϑ_{Start} = higher of 60 °C or higher value determined by last paragraph of Annex B.
- for arresters for $U_s > 800$ kV: start temperature as determined by the procedure of Annex I

The preheating shall take not more than twenty hours.

The temperature of the MO resistors shall be at least the start temperature immediately prior to the injection of energy or transfer of charge.

Each sample shall be subjected to injection of energy or transfer of charge within three minutes as follows:

- a) for arresters not intended for application on overhead transmission or distribution lines (i.e. intended for use in stations): energy administered in the form of long-duration (rectangular) impulses of 2 ms to 4 ms virtual total duration or unipolar half sine-wave impulses of 2 ms to 4 ms total duration within a time of three minutes. The choice of the number of impulses is up to the manufacturer, provided the impulses are administered within the specified 3 minute period. The current amplitudes and number of impulses is not critical, provided the accumulated energy is at least equal to the following:
 - for single column arresters: 1.0 to 1.1 times the claimed thermal energy rating (selected from the list given in 8.7.3);
 - for multi-column arresters: 1.0 to 1.1 times to the claimed thermal energy rating (selected from the list given in 8.7.3) multiplied by the current sharing factor β_g/β_a (see item c) of 7.3).

NOTE Annex K provides an example of how to determine the actual energy to be injected based on the claimed W_{th} and on the characteristics of the pro-rated section.
 - b) for NGLA: lightning impulse discharges according to Annex H.
 - c) for distribution class arresters: charge administered in the form of two 8/20 lightning current impulses within one minute, having a sufficient magnitude that the accumulated charge is at least equal to the claimed thermal charge transfer rating selected from the list given in Table 5.
- Within 100 ms from the energy or charge application, a voltage equal to the rated voltage U_r shall be applied for 10 s and thereafter a voltage equal to the continuous operating voltage U_c (if necessary further adjusted as per 7.3) shall be applied for a minimum of 30 minutes to demonstrate thermal stability. Resistive component of current or power dissipation or temperature or any combination of them shall be monitored until the measured value is appreciably reduced (success), but for at least 30 minutes, or thermal runaway condition (failure) is evident.

8.7.2.4 Test evaluation

The test shall be considered passed if all the following criteria are met:

- thermal recovery has been demonstrated;
- no physical damage is evident;
- any change of the residual voltage at nominal discharge current before and after the test is within ± 5 %.

8.7.3 Rated thermal energy and charge values, W_{th} and Q_{th}

For station class arresters, the values of thermal energy rating, W_{th} , given in kJ/kV of rated voltage U_r , shall conform to the requirements of Table 1 and shall be taken from the following list:

- from 1 kJ/kV to 5 kJ/kV in steps of 0,5 kJ/kV

- from 5 kJ/kV to 16 kJ/kV in steps of 1 kJ/kV
- from 16 kJ/kV to 30 kJ/kV in steps of 2 kJ/kV
- from 30 kJ/kV up in steps of 6 kJ/kV

For distribution arresters, the values of thermal charge rating, Q_{th} , given in C, shall be taken from Table 5.

Table 5 – Rated values of thermal charge transfer rating, Q_{th}

Nominal discharge current (kA)	Q_{th} rating (C)	Q_{th} per impulse (C)	Corresponding 8/20 μ s current amplitude (kA) (approximately) (informative)
2,5	0,45	0,23 (± 10 %)	14
5	0,7	0,35 (± 10 %)	22
10	1,1	0,55 (± 10 %)	34

8.8 Power-frequency voltage-versus-time test

8.8.1 General

The purpose of this test is to demonstrate the TOV (temporary overvoltage) withstand capability of the arrester. In this test, the TOV is strictly a power-frequency overvoltage for time periods from 0,1 s to 3 600 s.

Manufacturers' published data shall include curves with abscissa scaled in time and ordinate in per unit of U_r . In addition, the manufacturer shall publish a table of TOV values listed in per unit of U_r to three significant digits, for times 0,1 s, 1 s, 10 s, 100 s, and 1 000 s. The table values shall be taken from the curves and shall include data "without prior duty" and "with prior duty". The published curve and table shall state the range of arrester ratings for which they apply.

The TOV value "with prior duty" and 10 s time duration shall be at least equal to U_r .

Figure 4 gives an overview of the test procedure.

<p>Initial tests</p> <ul style="list-style-type: none"> • Residual voltage test at nominal discharge current • Reference voltage test at specified reference current • Check for correct current sharing in case of multi-column arrester design
<p>Determination of continuous operating voltage and rated voltage, if necessary adjusted as per 7.3</p>
<p>Preheating to start temperature as per 8.7.2.3</p>
<p>With prior duty (4 new samples) (only for arresters of $I_n \geq 10$ kA)</p> <ul style="list-style-type: none"> • Station class arresters: Rated thermal energy injection, W_{th}, within three minutes by one or more long-duration current impulses or by unipolar sine half-wave current impulses or, in case of NGLA, by lightning impulse discharges according to 8.7.3 • Distribution class arresters: Rated thermal charge transfer, Q_{th}, within one minute by two lightning current impulses 8/20 μs according to 8.7.3 • Application of test voltage and duration according to TOV curve (within 100 ms) • Application of U_c for at least 30 min (until pass or fail is evident)
<p>Without prior duty (2 new samples)</p> <ul style="list-style-type: none"> • Application of test voltage and duration according to TOV curve • Application of U_c for at least 30 min (until pass or fail is evident)
<p>Test evaluation</p> <ul style="list-style-type: none"> • Thermal recovery • No physical damage • Change of residual voltage at nominal discharge current within $\pm 5\%$

Figure 4 – Test procedure to verify the power frequency versus time characteristic (TOV test)

8.8.2 Test samples

The test samples shall fulfil the requirements in 7.3.

The test samples shall be thermally prorated sections according to 7.3.2.1. The rated voltage of the prorated sections shall be not less than 3 kV, but need not exceed 12 kV. Alternatively, complete arresters with rated voltages of 9 kV to 12 kV may be used provided the arrester's cooling rate represents the slowest cooling rate for all ratings of the design.

A total of six samples shall be tested as follows:

“with prior duty” – one sample in each of the **four** ranges listed in 8.8.4.2

“without prior duty” – one sample in each of **two** ranges selected from the list in 8.8.4.2.

For a given type and design arrester, when various size MO resistors are used, the MO resistors selected for the TOV test section shall have the minimum material volume per U_c .

8.8.3 Initial measurements

Following initial measurements shall be performed:

- Residual voltage test at nominal discharge current.
- Reference voltage test at specified reference current. The reference voltage test is necessary to calculate the continuous operating voltage and the rated voltage.
- For multi-column arresters the distribution of the current between the columns shall be measured at the impulse current for current distribution test (see item e) of 9.1). The highest current value shall not be higher than an upper limit specified by the manufacturer.

8.8.4 Test procedure

8.8.4.1 General

The test sample shall be connected to a power supply having a frequency within the range of 48 Hz to 62 Hz. Nominal test frequency (50 Hz or 60 Hz) shall be stated with published data. The peak values of power-frequency voltage shall be measured at the arrester terminals during the overvoltage. The minimum measured peak value divided by $\sqrt{2}$ is the per-unit value that shall be used for data display referenced to U_r .

Care must be taken in the case of a weak voltage source. Distortion of the voltage (flat peak) under severe non-linear current loading may lead to much higher energy injection at a given peak voltage level compared to the situation for an ideally sinusoidal voltage shape. It is therefore recommended to use a voltage source of a short-circuit current of at least 3 kA in order to avoid unrealistically high energy injection to the sample at a given peak voltage level.

The tests shall be performed in still air at $20\text{ °C} \pm 15\text{ K}$ on thermally prorated sections. The samples shall be heated for a time sufficient to obtain thermal equilibrium, and the MO resistors shall be at a temperature of at least ϑ_{Start} (determination of ϑ_{Start} according to 8.7.2). It shall be demonstrated by adequate methods that the start temperature requirement is fulfilled at the beginning of the thermal recovery parts of the test.

8.8.4.2 “With prior duty” test

This test is applicable to arresters of $I_n \geq 10\text{ kA}$ only. Four new test samples shall be tested “with prior duty”. One sample each shall be tested in the ranges (in seconds) given below:

- 1) 0,1 to 1
- 2) 1,1 to 10
- 3) 10,1 to 100
- 4) 101 to 3 600

The manufacturer shall publish TOV data for conditions “with prior duty” for each of the four listed time periods. The prior duty consists of injection of the thermal energy W_{th} or of transfer of the thermal charge rating Q_{th} , in case of multi-column designs corrected by the factor β_g/β_a . The test procedure shall be the procedure given in 8.7.2.3, where the rated voltage U_r is replaced by the specified TOV. The injected energy (in kJ/kV of U_r) or charge (in C), respectively, shall be measured and shall be stated with the relevant published prior duty TOV data.

8.8.4.3 “Without prior duty” test

This test is applicable to arresters of all nominal discharge currents. Two new test samples shall be tested “without prior duty”. The manufacturer shall publish TOV data for conditions “without prior duty” for two of the four time periods listed in 8.8.4.2. One new sample in each of two non-adjacent time ranges selected from this list shall be tested. Immediately after the overvoltage, the continuous operating voltage U_c (if necessary further adjusted as per 7.3)

shall be applied for a minimum of 30 min. MO resistor temperature, resistive component of current or power dissipation shall be monitored until the measured value is appreciably reduced (success) or a thermal runaway condition is evident (failure).

8.8.5 Test evaluation

A sample shall be considered passed if all the following criteria are met:

- thermal recovery has been demonstrated;
- no physical damage is evident;
- any change of the residual voltage at nominal discharge current before and after the test is within $\pm 5\%$.

The manufacturer's published curve has been verified when all six samples have been tested at TOV voltages and corresponding durations that are equal to or greater than the values indicated on the curve, and all samples have passed the evaluation criteria. All test points shall be displayed on the curve.

8.9 Tests of arrester disconnecter

8.9.1 General

The purpose of the disconnecter test is to verify that the disconnecter of an arrester can withstand all stresses related to their application in arresters without operating. The test also demonstrates that the disconnecter will perform according to the time-current characteristic published by the manufacturer. Furthermore the water tightness and the mechanical strength of the disconnecter have to be verified (see 6.14).

These tests shall be made on arresters which are fitted with arrester disconnecters or on the disconnecter assembly alone if its design is such as to be unaffected by the heating of adjacent parts of the arrester in its normally installed position. The test sample shall be mounted in accordance with the manufacturer's published recommendations using the maximum recommended size and stiffness and the shortest recommended length of connecting lead. In the absence of published recommendations, the conductor shall be hard-drawn bare copper approximately 5 mm in diameter and 30 cm long, arranged to allow freedom of movement of the disconnecter/fault indicator when it operates.

8.9.2 Operating withstand test

8.9.2.1 General

For disconnecters designed for attachment to an arrester or for insertion into the line or ground lead as an accessory, a charge transfer test and an operating duty test shall be made either separately or in conjunction with tests on arrester samples. For arresters with built-in disconnecters, the tests shall be made at the same time as the tests on the arresters. The disconnecters shall withstand the tests without operating.

8.9.2.2 Test to verify the repetitive charge transfer rating Q_{rs}

This test shall be made in accordance with 8.5, with charge transfer values corresponding to the highest classification of arresters with which the disconnecter is designed to be used. For distribution class arresters the test shall be made with lightning impulse currents 8/20 μs . For non gapped line arresters (NGLA) the test shall be made with lightning impulse discharges according to 3.32 or with long duration currents depending on the application. The test shall be made on three samples with the same charge as specified for the arrester (see 8.5.4).

8.9.2.3 Operating duty test

This test shall be made in accordance with 8.7 with the sample disconnector in series with a test sample section of the arrester design having the highest reference current of all the arresters with which it is designed to be used. The test shall be made on three samples with the same thermal charge or thermal energy rating as specified for the arrester.

NOTE There is no NGLA known at the moment where disconnectors are included.

8.9.2.4 Test evaluation

The tests shall be considered passed if

there is no operation of any sample during the testing of 8.9.2.2 and 8.9.2.3

and

either

- the resistance or capacitance of the grading elements have not changed by more than 20 %

or

- if each of the samples used for the tests of 8.9.2.2 and 8.9.2.3 successfully operates in a subsequent test of operation when conducting a current of 20 A rms symmetrical

8.9.3 Disconnector operation

8.9.3.1 Time versus current test

An operation test shall be made on arrester disconnectors to determine a time-current characteristic; that is, the relation between the time in seconds and the current in rms symmetrical amperes required to cause the disconnector to operate. It is permissible for the actual operation of the disconnector to occur after the current has ceased.

For distribution class arresters data for a time-versus-current curve shall be obtained at three different symmetrically initiated current levels with five samples each – 20 A, 200 A and 800 A r.m.s. $\pm 10\%$ – flowing through test sample disconnectors with or without arresters as required by 8.9.1. If lower currents are claimed they shall be tested (e.g. 5 A). For tests on disconnectors affected by internal heating of the associated arresters, the MO resistors in the arrester shall be bypassed with a bare copper wire 0,08 mm to 0,13 mm in diameter in order to start the internal arcing.

For NGLA the test currents shall be specified by agreement between user and manufacturer. For tests on disconnectors unaffected by the operation of the associated arrester, the arrester, if it is used for mounting the disconnector, shall have its grading element (resistor / capacitor) shunted or replaced by a conductor of size sufficient to ensure that it will not be melted during the test.

The test voltage may be any convenient value so long as it is sufficient to maintain full current flow in the arc over the arrester elements and sufficient to cause and maintain arcing of any gaps upon which operation of the disconnector may depend. The test voltage shall not exceed the rated voltage of the lowest rated arrester with which the disconnector is designed to be used.

Because the disconnector is not a fault-clearing device, the test circuits shall include devices with interrupting capabilities. An opening device such as a fuse or switch may be used with provision for adjusting the duration of current through the test sample.

NOTE One method of preparing the test circuit is to first adjust the parameters of the test circuit with the test sample temporarily shunted by a link of negligible impedance to produce the required value of current. A closing

switch can be timed to close the circuit within a time corresponding to a few degrees of voltage crest to produce approximately symmetrical current.

The r.m.s. value of current through the specimen and the duration to the first movement of the disconnecter shall be plotted for all the samples tested. The time-versus-current characteristic curve of the disconnecter shall be drawn as a smooth curve through the points representing maximum duration.

Depending on the test setup and the amplitude of the test current the arc will not distinguish after disconnecter operation. In this case the time-versus-current curve test shall be made by subjecting the test samples to controlled durations of current flow to determine the minimum duration for each of the three current levels which will consistently result in successful operation of the disconnecter. For the points to be used for the time-versus-current curve, successful operation of the disconnecter shall occur in five tests out of five trials, or, if one unsuccessful test occurs, five additional tests at the same current level and duration shall result in successful operations.

8.9.3.2 Evaluation of disconnecter performance

There shall be clear evidence of effective and permanent disconnection by the device. If there is no clear evidence of effective and permanent disconnection by the device, a power-frequency voltage equal to 1,2 times the rated voltage of the highest rated arrester with which the disconnecter is designed to be used, shall be applied for 1 min without current flow in excess of 1mA r.m.s. At each value of current, the established characteristic curve shall have a time value that is equal to or lower than that shown in manufacturer's published data.

8.9.4 Mechanical tests

8.9.4.1 General

Bending moment, tensile load and torsional load tests shall be performed on disconnectors used with NGLA. For arresters other than NGLA these tests may be performed on agreement between user and manufacturer.

NOTE Typically, disconnectors used on distribution class arresters would be subjected to very small loading due to weight of connecting leads, and would therefore not be subject to this test. However, disconnectors might be exposed to torque or other loads during installation even though mechanical stress in service is negligible.

8.9.4.2 Bending moment test

The test shall be made on five new samples. On each sample, the bending load shall be increased smoothly until breaking occurs within 30 s to 90 s. The test is passed if the values of breaking load exceed the value specified by the manufacturer. If one sample fails to reach the specified breaking value, five additional samples shall be tested successfully.

8.9.4.3 Tensile load test

The test shall be made on five new samples. On each sample, the tensile load shall be increased smoothly until breaking occurs within 30 s to 90 s. The test is passed if the values of breaking load exceed the value specified by the manufacturer. If one sample fails to reach the specified breaking value, five additional samples shall be tested successfully.

8.9.4.4 Torsional load test

The test shall be made on five new samples. On each sample, the torsional load shall be increased smoothly until breaking occurs within 30 s to 90 s. The test is passed if the values of breaking load exceed the value specified by the manufacturer. If one sample fails to reach the specified breaking value, five additional samples shall be tested successfully.

8.9.5 Temperature cycling and seal pumping test

A temperature cycling test shall be made on 10 new samples, in accordance with 8.12.3.1, followed by a seal pumping test on each sample.

In the seal pumping test the test samples shall be uniformly heated to $60\text{ °C} \pm 3\text{ °C}$ and maintained at that temperature for a minimum of 1 h. The samples shall then be placed in a cold water bath having a temperature of $4\text{ °C} \pm 3\text{ °C}$ for a minimum of 2 h. The transfer time between the hot and cold media shall be not more than 5 min. The test cycle shall be performed 10 times. The cold water bath shall have a water weight at a minimum of 10 times the weight of the test samples.

Within 24 h after having reached ambient temperature the resistance or capacitance of the grading element of each sample shall be measured and the samples shall be opened for visual inspection. The disconnectors shall have passed the tests if no moisture is found within the test samples upon visual examination of the internal parts and surfaces and if the resistance or capacitance of the grading element has not changed by more than 20 %.

8.10 Short-circuit tests

8.10.1 General

All arresters shall be tested in accordance with Subclause 8.10. The test shall be performed in order to show that an arrester failure does not result in a violent shattering of the arrester housing, and that self-extinguishing of open flames (if any) occurs within a defined period of time. Each arrester type is tested with up to four values of short-circuit currents. If the arrester is equipped with some other arrangement as a substitute for a conventional pressure relief device, this arrangement shall be included in the test.

The frequency of the short-circuit test current supply shall be between 48 Hz and 62 Hz.

With respect to the short-circuit current performance, it is important to distinguish between two designs of surge arresters.

“Design A” arresters have a design in which a gas channel runs along the entire length of the arrester unit and fills $\geq 50\%$ of the internal volume not occupied by the internal active parts.

“Design B” arresters are of a solid design with no enclosed volume of gas or having an internal gas volume filling $< 50\%$ of the internal volume not occupied by the internal active parts.

NOTE 1 Typically, “Design A” arresters are porcelain-housed arresters, or polymer-housed arresters with a composite hollow insulator which are equipped either with pressure-relief devices, or with prefabricated weak spots in the composite housing which burst or flip open at a specified pressure, thereby decreasing the internal pressure.

Typically, “Design B” arresters do not have any pressure relief device and are of a solid type with no enclosed volume of gas. If the MO resistors fail electrically, an arc is established within the arrester. This arc causes heavy evaporation and possibly burning of the housing and/or internal material. These arresters' short-circuit performance is determined by their ability to control the cracking or tearing-open of the housing due to the arc effects, thereby avoiding violent shattering.

NOTE 2 "Active parts" in this context are the MO resistors and any metal spacers directly in series with them.

NOTE 3 After agreement between the manufacturer and the user, the test procedure can be modified to include, for example, a number of reclosing operations, with the procedure and acceptance criteria being agreed upon between the manufacturer and the user.

8.10.2 Preparation of the test samples

8.10.2.1 General

Depending on the type of arrester and test voltage, different requirements apply with regard to the number of test samples, initiation of short-circuit current and amplitude of the first short-circuit current peak. Table 6 shows a summary of these requirements which are further explained in the following subclauses.

For the high-current tests, the test samples shall be the longest arrester unit used for the design with the highest rated voltage of that unit used for each different arrester design.

For the low-current test, the test sample shall be an arrester unit of any length with the highest rated voltage of that unit used for each different arrester design. Figure 5 shows different examples of arrester units.

8.10.2.2 “Design A” arresters

The samples shall be prepared with means for conducting the required short-circuit current using a fuse wire. The fuse wire shall be in direct contact with the MO resistors and be positioned within, or as close as possible to, the gas channel and shall short-circuit the entire internal active part, as illustrated in Figure 6 for different possible constructions of Design A arresters. The actual location of the fuse wire in the test shall be reported in the test report.

The fuse wire material and size shall be selected so that, for the high and reduced short - circuit current tests, the wire will melt within the first 30 electrical degrees after initiation of the test current. For the low short-circuit current test, there is no limitation on time to melt.

In order to have melting of the fuse wire within the specified time limit and create a suitable condition for arc ignition, it is generally recommended that a fuse wire of a low resistance material (for example copper, aluminium or silver) with a diameter of about 0,2 mm to 0,5 mm be used. Higher fuse-wire cross-sections are applicable to surge arrester units prepared for higher short-circuit test currents. When there are problems in initiating the arc, a fuse wire of larger size but with a diameter not exceeding 1,5 mm, may be used since it will help arc establishment. In such cases, a specially prepared fuse wire, having a larger cross-section along most of the arrester height with a short thinner section in the middle, may also help.

“Design A” arresters with polymeric sheds which are applied to a primary housing of porcelain or other hollow insulator that is as brittle as ceramic, shall be considered and tested as porcelain-housed arresters.

The test samples must be filled with the surrounding medium (gas) used in the arresters.

8.10.2.3 “Design B” arresters

The samples shall be prepared with means for conducting the required short-circuit current using a fuse wire. The fuse wire shall be in direct contact with the MO resistors and be located as far away as possible from the gas channel and shall short-circuit the entire internal active part, as illustrated in Figure 7 for different possible constructions of Design B arresters. The actual location of the fuse wire in the test shall be reported in the test report.

The fuse wire material and size shall be selected so that, for the high and reduced short-circuit current tests, the wire will melt within the first 30 electrical degrees after initiation of the test current. For the low short-circuit current test, there is no limitation on time to melt.

In order to have melting of the fuse wire within the specified time limit and create a suitable condition for arc ignition, it is generally recommended that a fuse wire of a low resistance material (for example copper, aluminium or silver) with a diameter of about 0,2 mm to 0,5 mm be used. Higher fuse-wire cross-sections are applicable to surge arrester units prepared for

higher short-circuit test currents. When there are problems in initiating the arc, a fuse wire of larger size but with a diameter not exceeding 1,5 mm, may be used since it will help arc establishment. In such cases, a specially prepared fuse wire, having a larger cross-section along most of the arrester height with a short thinner section in the middle, may also help.

In case of an internal gas volume the test samples must be filled with the surrounding medium (gas) used in the arresters.

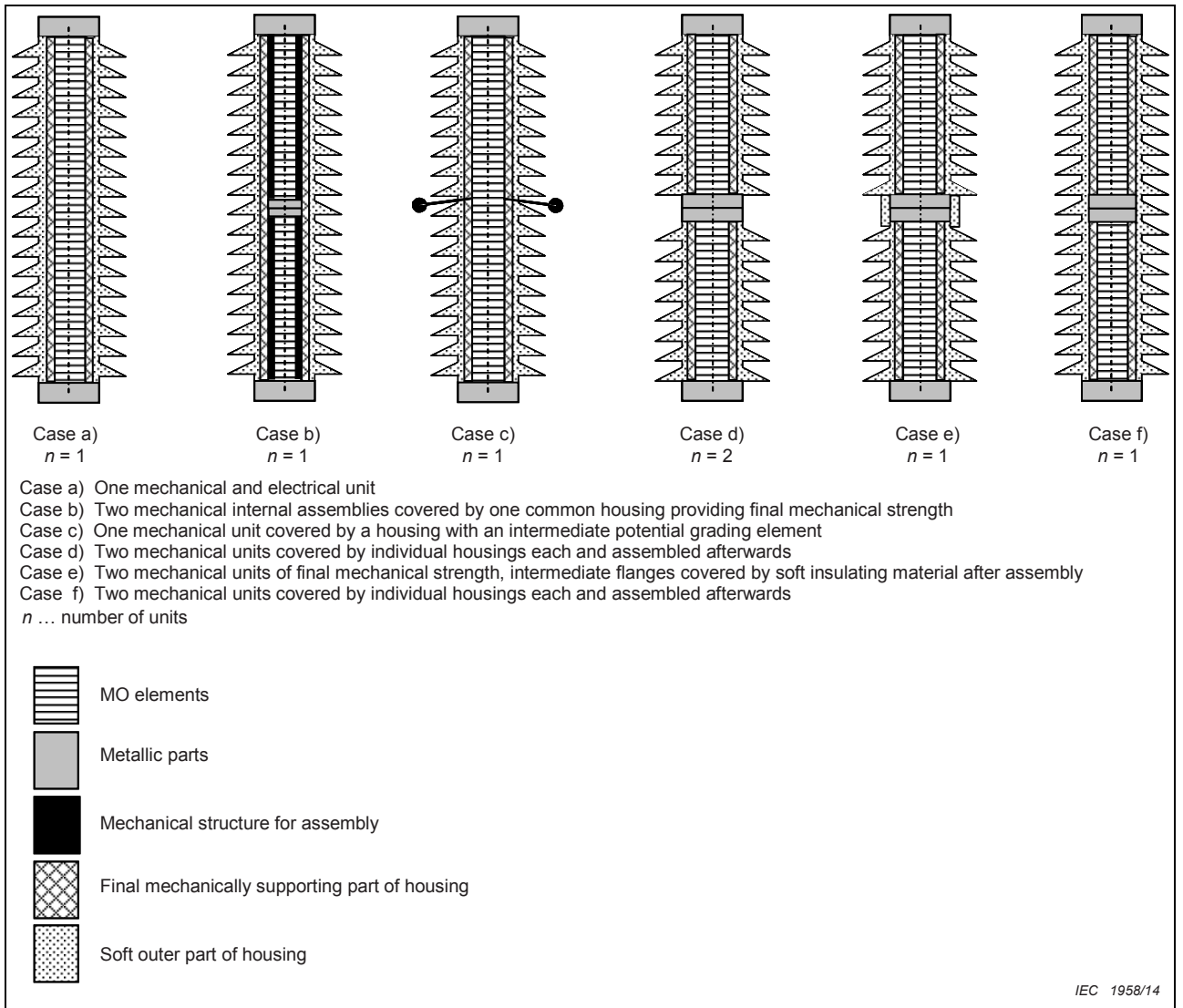

Figure 5 – Examples of arrester units

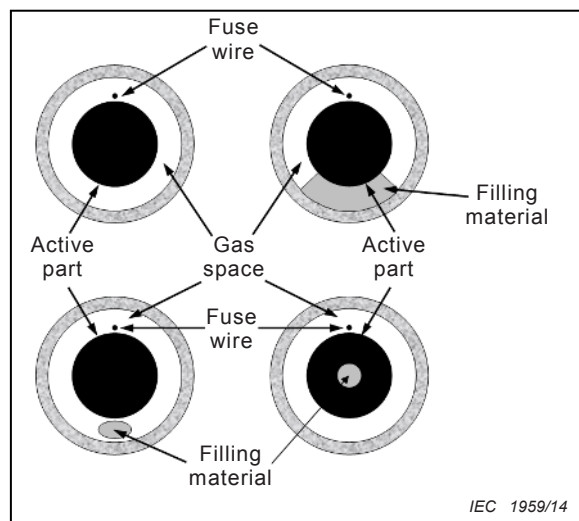

Figure 6 – Examples of fuse wire locations for “Design A” arresters

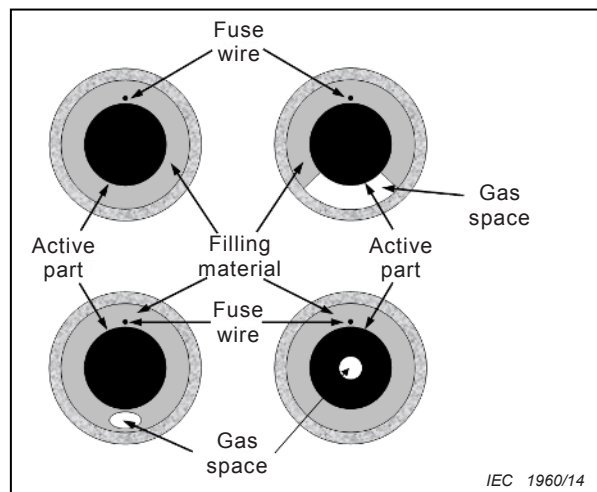
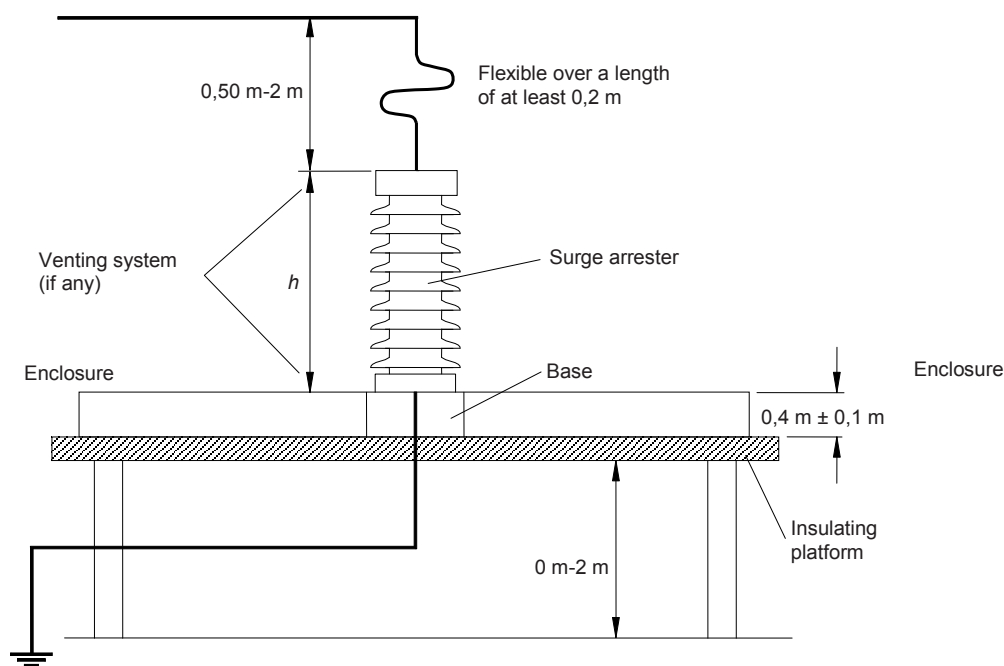

Figure 7 – Examples of fuse wire locations for “Design B” arresters

8.10.3 Mounting of the test sample

For a base-mounted arrester, the mounting arrangement is shown in Figure 8. The distance to the ground from the insulating platform and the conductors shall be as indicated in this figure.



NOTE All leads and venting systems in the same plane.

Figure 8 – Short-circuit test setup for porcelain-housed arresters

For non-base-mounted arresters (for example, pole-mounted arresters), the test sample shall be mounted on a non-metallic pole using mounting brackets and hardware typically used for real service installation. For the purpose of the test, the mounting bracket shall be considered as a part of the arrester base. In cases where the foregoing is at variance with the manufacturer's instructions, the arrester shall be mounted in accordance with the installation recommendations of the manufacturer. The entire lead between the base and the current sensor shall be insulated for at least 1 000 V. The top end of the test sample shall be fitted with the base assembly of the same design of an arrester or with the top cap.

For base-mounted arresters, the bottom end fitting of the test sample shall be mounted on a test base that is at the same height as a surrounding circular or square enclosure. The test base shall be of insulating material or may be of conducting material if its surface dimensions are smaller than the surface dimensions of the arrester bottom end fitting. The test base and the enclosure shall be placed on top of an insulating platform, as shown in Figure 8. For non-base-mounted arresters, the same requirements apply to the bottom of the arrester. The arcing distance between the top end cap and any other metallic object (floating or grounded), except for the base of the arrester, shall be at least 1,6 times the height of the sample arrester, but not less than 0,9 m. The enclosure shall be made of non-metallic material and be positioned symmetrically with respect to the axis of the test sample. The height of the enclosure shall be $40 \text{ cm} \pm 10 \text{ cm}$, and its diameter (or side, in case of a square enclosure) shall be equal to the greater of 1,8 m or D in Equation (1) below. The enclosure shall not be permitted to open or move during the test.

$$D = 1,2 \times (2 \times H + D_{\text{arr}}) \quad (1)$$

where

- H is the height of tested arrester unit;
 D_{arr} is the diameter of tested arrester unit.

Test samples shall be mounted vertically unless agreed upon otherwise between the manufacturer and the user. In the event that physical space limitations of the laboratory do not permit an enclosure of the specified size, the manufacturer may choose to use an enclosure of lesser diameter.

The mounting of the arrester during the short-circuit test and, more specifically, the routing of the conductors shall represent the most unfavourable condition in service.

NOTE The routing shown in Figure 8 is the most unfavourable to use during the initial phase of the test before venting occurs (especially in the case of a surge arrester fitted with a pressure relief device). Positioning the sample as shown in Figure 8, with the venting ports facing in the direction of the test source, may cause the external arc to be swept in closer proximity to the arrester housing than otherwise. As a result, a thermal shock effect may cause excessive chipping and shattering of porcelain weather sheds, as compared to the other possible orientations of the venting ports.

8.10.4 High-current short-circuit tests

8.10.4.1 General

A total of three samples shall be tested at currents based on selection of a rated short-circuit current selected from Table 7. All three samples shall be prepared according to 8.10.2 and mounted according to 8.10.3.

Tests shall be made in a single-phase test circuit, preferably with an open-circuit test voltage of 77 % to 107 % of the rated voltage of the test sample, as outlined in 8.10.4.2. However, it is expected that tests on high-voltage arresters will have to be made at laboratories which might not have the sufficient short-circuit power capability to carry out these tests at 77 % or more of the test sample rated voltage. Accordingly, an alternative procedure for making the high-current, short-circuit tests at a reduced voltage is given in 8.10.4.3. The measured total duration of test current flowing through the circuit shall be $\geq 0,2 \text{ s}$.

Table 7 – Required currents for short-circuit tests

Arrester class = nominal discharge current	Rated short-circuit current I_s	Reduced short-circuit currents $\pm 10\%$		Low short-circuit current with a duration of 1 s ^a
kA	kA	kA		A
20 or 10	80	50	25	600 \pm 200
20 or 10	63	25	12	600 \pm 200
20 or 10	50	25	12	600 \pm 200
20 or 10	40	25	12	600 \pm 200
20 or 10	31,5	12	6	600 \pm 200
20, 10 or 5	20	12	6	600 \pm 200
10 or 5	16	6	3	600 \pm 200
10, 5, or 2,5	10	6	3	600 \pm 200
10, 5, or 2,5	5	3	1,5	600 \pm 200
10, 5 or 2,5	2,5 kA	–	–	600 \pm 200
10, 5 or 2,5	1 kA	–	–	Amplitude and time on agreement between user and manufacturer
10, 5 or 2,5	< 1 kA ^b	–	–	Amplitude and time on agreement between user and manufacturer

^a For surge arresters to be installed in resonant earthed or unearthed neutral systems, the increase of the test duration to longer than 1 s, up to 30 min, may be permitted after agreement between the manufacturer and the user. In this case the low short-circuit current shall be reduced to 50 A \pm 20 A, and the test sample and acceptance criteria shall be agreed between the manufacturer and the user.

^b High current tests are not required in this case.

NOTE If an existing arrester is qualified for one of the rated short-circuit currents in this table, it is deemed to have passed the test for any value of rated current lower than this one.

If an existing type of arrester already qualified for one of the rated currents in this table is being qualified for a higher rated-current value available in the table, it should be tested only at the new rated value. Any extrapolation can only be extended by two steps of rated short-circuit current.

If a new arrester type is to be qualified for a higher rated current value than available in this table, it shall be tested at the proposed rated current, at 50 % and at 25 % of this rated current.

8.10.4.2 High-current tests at full voltage (77 % to 107 % of rating)

The prospective current shall first be measured by making a test with the arrester short-circuited or replaced by a solid link of negligible impedance.

The duration of such a test may be limited to the minimum time required to measure the peak and symmetrical component of the current waveform.

For “Design A” arresters tested at the rated short-circuit current, the peak value of the first half-cycle of the prospective current shall be at least 2,5 times the r.m.s value of the rated short circuit current selected from Table 7. The following r.m.s. value of the symmetrical component shall be equal to the rated short-circuit current or higher. The peak value of the prospective current, divided by 2,5, shall be quoted as the test current, even though the r.m.s. value of the symmetrical component of the prospective current may be higher. Because of the higher prospective current, the sample arrester may be subjected to more severe duty, and,

therefore, tests at X/R ratio lower than 15 shall only be carried out with the manufacturer's consent.

For "Design B" arresters tested at rated short-circuit current, the peak value of the first half-cycle of the prospective current shall be at least $\sqrt{2}$ times the r.m.s. value of the rated short circuit current .

For all the reduced short-circuit currents, the r.m.s. value shall be in accordance with Table 7 and the peak value of the first half-cycle of the prospective current shall be at least $\sqrt{2}$ times the r.m.s. value of this current.

The solid shorting link shall be removed after checking the prospective current and the arrester sample(s) shall be tested with the same circuit parameters.

NOTE The resistance of the restricted arc inside the arrester might reduce the r.m.s. symmetrical component and the peak value of the measured current. This does not invalidate the test, since the test is being made with at least normal service voltage and the effect on the test current is the same as would be experienced during a fault in service.

The X/R ratio of the test circuit impedance, without the arrester connected, should preferably be at least 15. In cases where the test circuit impedance X/R ratio is less than 15, the test voltage may be increased or the impedance may be reduced, in such a way that,

for the rated short-circuit current, the peak value of the first half-cycle of the prospective current is equal to, or greater than, 2,5 times the required test current level;

for the reduced current level tests, the tolerances in Table 7 are met.

8.10.4.3 High-current test at less than 77 % of rated voltage

When tests are made with a test circuit voltage <77 % of the rated voltage of the test samples, the test circuit parameters shall be adjusted in such a way that the r.m.s. value of the symmetrical component of the actual arrester test current shall equal or exceed the required test current selected from Table 7.

For "Design A" arresters tested at the rated short-circuit current, the peak value of the first half-cycle of the actual arrester test current shall be at least 2,5 times the r.m.s. value of the rated short circuit current selected from Table 7. The following r.m.s. value of the symmetrical component shall be equal to the rated short-circuit current or higher. The peak value of the actual arrester test current, divided by 2,5 shall be quoted as the test current, even though the r.m.s. value of the symmetrical component of the actual arrester test current may be higher.

For "Design B" arresters tested at rated short-circuit current, the peak value of the first half-cycle of the actual arrester test current shall be at least $\sqrt{2}$ times the r.m.s. value of the rated short circuit current.

For all the reduced short-circuit currents the r.m.s. value shall be in accordance with Table 7 and the peak value of the first half-cycle of the actual arrester test current shall be at least $\sqrt{2}$ times the r.m.s. value of this current.

Especially for tall arresters that are tested at a low percentage of their rated voltage, the first asymmetric peak current of 2,5 is not easily achieved unless special test possibilities are considered. It is thus possible to increase the test r.m.s. voltage or reduce the impedance so that, for the rated short-circuit current, the peak value of the first half-cycle of the test current is equal to, or greater than, 2,5 times the required test current level. In case of testing with a generator, the first peak of 2,5 times the required test current can also be achieved by varying the generator's excitation. The current should then be reduced, not less than 2,5 cycles after initiation, to the required symmetrical value. The actual peak value of the test current, divided by 2,5, should be quoted as the test current, even though the r.m.s. value of the symmetrical component of the actual arrester test current may be higher. Because of the higher test

current, the sample arrester may be subjected to more severe duty and, therefore, tests at X/R ratio lower than 15 should only be carried out with the manufacturer's consent.

8.10.5 Low-current short-circuit test

The test shall be made by using any test circuit that will produce a current through the test sample of $600 \text{ A} \pm 200 \text{ A}$ r.m.s., measured at approximately 0,1 s after the start of the short circuit current flow. The current shall flow for at least 1 s after the fuse wire melts or, for "Design A" arresters, until venting occurs.

Refer to 8.10.6 with regard to handling an arrester that fails to vent.

8.10.6 Evaluation of test results

The test is considered successful if the following three criteria are met.

- a) No violent shattering. Structural failure of the sample is permitted as long as criteria b) and c) are met.
- b) No parts of the test sample shall be allowed to be found outside the enclosure, except for
 - fragments, less than 60 g each, of ceramic material such as MO resistors or porcelain;
 - pressure relief vent covers and diaphragms;
 - soft parts of polymeric materials.
- c) The arrester shall be able to self-extinguish open flames within 2 min after the end of the test. Any ejected part (in or out of the enclosure) must also self-extinguish open flames within 2 min. A shorter duration of self-extinguishing open flames for ejected parts may be agreed upon between the manufacturer and the user.

If the arrester has not visibly vented at the end of the test, caution should be exercised, as the housing may remain pressurized after the test. This is applicable to all levels of test current, but is of particular relevance to the low-current, short-circuit tests.

For arresters to be used in applications where mechanical integrity and a strength is required after failure, different test procedures and evaluations may be established between the manufacturer and the user (as an example, it may be required that after the tests the arrester should still be able to be lifted and removed by its top end).

8.11 Test of the bending moment

8.11.1 General

This test applies to porcelain and cast-resin housed arresters for $U_s > 52 \text{ kV}$. It also applies to porcelain and cast-resin housed arresters for $U_s \leq 52 \text{ kV}$ for which the manufacturer claims cantilever strength. The test shall be performed on the arrester without insulating base or mounting bracket.

The complete test procedure is shown by the flow chart in Annex G.

8.11.2 Overview

This test demonstrates the ability of the arrester to withstand the manufacturer's declared values for bending loads. Normally, an arrester is not designed for torsional loading. If an

arrester is subjected to torsional loads, a specific test may be necessary by agreement between manufacturer and user.

The test shall be performed on complete arrester units without insulating base or mounting bracket and without internal overpressure. For single-unit arrester designs, the test shall be performed on the longest unit of the design. Where an arrester contains more than one unit or where the arrester has different specified bending moments in both ends, the test shall be performed on the longest unit of each different specified bending moment, with loads determined according to G.1.

The test shall be performed in two parts that may be done in any order:

a bending moment test to determine the mean value of breaking load (MBL);

a static bending moment test with the test load equal to the specified short-term load (SSL), i.e. the 100 % value of G.3.

8.11.3 Sample preparation

One end of the sample shall be firmly fixed to a rigid mounting surface of the test equipment, and a load shall be applied to the other (free) end of the sample to produce the required bending moment at the fixed end. The direction of the load shall pass through and be perpendicular to the longitudinal axis of the arrester. If the arrester is not axi-symmetrical with respect to its bending strength, the manufacturer shall provide information regarding this non-symmetric strength, and the load shall be applied in an angular direction that subjects the weakest part of the arrester to the maximum bending moment.

8.11.4 Test procedure

8.11.4.1 Test procedure to determine mean value of breaking load (MBL)

Three samples shall be tested. If the test to verify the SSL (see 8.11.4.2) is performed first, then samples from that test may be used for determination of MBL. The test samples need not contain the internal parts. On each sample, the bending load shall be increased smoothly until breaking occurs within 30 s to 90 s. "Breaking" includes fracture of the housing and damages that may occur to fixing device or end fittings.

The mean breaking load, MBL, is calculated as the mean value of the breaking loads for the test samples.

NOTE The housing of an arrester might splinter while under load and might present a handling hazard.

8.11.4.2 Test procedure to verify the specified short-term load (SSL)

Three samples shall be tested. The test samples shall contain the internal parts. Prior to the tests, each test sample shall be subjected to a leakage check (see item d) of 9.1) and an internal partial discharge test (see item c) of 9.1). If these tests have been performed as routine tests, they need not be repeated at this time.

On each sample, the bending load shall be increased smoothly to SSL, tolerance $\pm 5\%$, within 30 s to 90 s. When the test load is reached, it shall be maintained for 60 s to 90 s. During this time the deflection shall be measured. Then the load shall be released smoothly and the residual deflection shall be recorded. The residual deflection shall be measured in the interval 1 min to 10 min after the release of the load.

NOTE The housing of an arrester might splinter while under load and might present a handling hazard.

8.11.5 Test evaluation

The arrester shall have passed the test if

the mean value of breaking load, MBL, is $\geq 1,2 \times \text{SSL}$;
for the SSL test

- there is no visible mechanical damage;
- the remaining permanent deflection is $\leq 3 \text{ mm}$ or $\leq 10 \%$ of maximum deflection during the test, whichever is greater;
- the test samples pass the leakage test in accordance with item d) of 9.1;
- the internal partial discharge level of the test samples does not exceed the value specified in 9.1 c).

8.11.6 Test on insulating base and mounting bracket

If the arrester is supplied with an insulating base and/or a mounting bracket, the base and/or bracket shall be subjected to a bending test. Three samples of each shall be tested. On each sample, the bending load shall be increased smoothly to a load equivalent to the arrester SSL within 30 s to 90 s. When the test load is reached, it shall be maintained for 60 s to 90 s. Then the load shall be released smoothly.

The samples shall have passed the test if there is no visible mechanical damage.

8.12 Environmental tests

8.12.1 General

These tests apply to porcelain and cast resin-housed arresters. The environmental tests demonstrate by accelerated test procedures that the sealing mechanism and the exposed metal combinations of the arrester are not impaired by environmental conditions.

The test shall be performed on complete arrester units of any length.

For arresters with an enclosed gas volume and a separate sealing system, the internal parts may be omitted.

Arresters whose units differ only in terms of their lengths, and which are otherwise based on the same design and material, and have the same sealing system in each unit, are considered to be the same type of arrester.

8.12.2 Sample preparation

Prior to the tests, the test sample shall be subjected to the leakage check of item d) of 9.1.

8.12.3 Test procedure

The tests specified below shall be performed on one sample in the sequence given.

8.12.3.1 Temperature cycling test

The test shall be performed according to test Nb of IEC 60068-2-14.

The hot period shall be at a temperature of at least $+40 \text{ }^\circ\text{C}$, but not higher than $+70 \text{ }^\circ\text{C}$. The cold period shall be at least 85 K below the value actually applied in the hot period; however, the lowest temperature in the cold period shall not be lower than $-50 \text{ }^\circ\text{C}$:

temperature change gradient: 1 K/min;

duration of each temperature level: 3 h;

number of cycles: 10.

8.12.3.2 Salt mist test

The test shall be performed according to Clause 4 and Subclause 7.6, as applicable, of IEC 60068-2-11:1981:

salt solution concentration: 5 % ± 1 % by weight;

test duration: 96 h.

8.12.4 Test evaluation

The arrester shall have passed the tests if the sample passes the leakage check in accordance with item d) of 9.1.

8.13 Seal leak rate test

8.13.1 General

This test applies to arresters having an enclosed gas volume and a separate sealing system. The test demonstrates the gas/water tightness of the complete system.

If a routine test for seal leak rate (see item d) of 9.1) is performed with acceptance criteria at least as stringent as specified in this clause, then a type test is not required. Otherwise, a type test shall be performed on one complete arrester unit. The internal parts may be omitted. If the arrester contains units with differences in their sealing system, the test shall be performed on one unit each, representing each different sealing system.

8.13.2 Sample preparation

The test sample shall be new and clean.

8.13.3 Test procedure

The manufacturer may use any sensitive method suitable for the measurement of the specified seal leak rate.

NOTE Some test procedures are specified in IEC 60068-2-17.

8.13.4 Test evaluation

The maximum seal leak rate (see G.4) shall be lower than $1 \times 10^{-6} \text{ Pa}\cdot\text{m}^3/\text{s}$

8.14 Radio interference voltage (RIV) test

These tests apply to open-air surge arresters intended for use on systems with $U_s \geq 72,5 \text{ kV}$. The test shall be performed on the longest arrester, with the highest rated voltage used for a particular arrester type. If other arrester types of lower ratings are equipped with exactly the same fittings (line and earth terminals, grading rings, etc.) they are qualified by the tests on the higher rated arrester and need not to be tested.

NOTE 1 A test on an element, part or unit of an arrester cannot be considered adequate because of the non-linearity of the potential distribution along a complete arrester.

NOTE 2 For this test, particular arrester type means also to have identical grading rings configurations.

This RIV test may be omitted if the same arrester has passed a partial discharge test following the general procedure of 9.1 c) but, in this case, with measurement of both internal and external discharges (i.e. with no shielding devices used for the connections or the grading rings or other parts of the arresters).

Surge arresters under test shall be fully assembled, and shall include the fittings (line and earth terminals, grading rings, etc.) that the manufacturer offers as standard equipment for the arrester.

The test voltage shall be applied between the terminals and the earthed base.

Earthed parts of the arrester shall be connected to earth. Care should be taken to avoid influencing the measurements by earthed or unearthed objects near to the surge arresters and to the test and measuring circuit.

The test connections and their ends shall not be a source of radio interference voltage of higher values than those indicated below.

The measuring circuit shall comply with CISPR/TR 18-2 of the International Special Committee on Radio Interference (CISPR). The measuring circuit should preferably be tuned to a frequency within 10 % of 0,5 MHz but other frequencies in the range 0,5 MHz to 2 MHz may be used, the measuring frequency being recorded. The results shall be expressed in microvolts.

If measuring impedances different from those specified in the CISPR publications are used, they shall be not more than 600 Ω or less than 30 Ω ; in any case, the phase angle shall not exceed 20°. The equivalent radio interference voltage referred to 300 Ω can be calculated, assuming the measured voltage to be directly proportional to the resistance.

The filter F shall have a high impedance so that the impedance between the high-voltage conductor and earth is not appreciably shunted as seen from the surge arrester under test. This filter also reduces circulating radiofrequency currents in the test circuit, generated by the high-voltage transformer or picked up from extraneous sources. A suitable value for its impedance has been found to be 10 000 Ω to 20 000 Ω at the measuring frequency.

Means shall be employed to ensure that the radio interference background level (radio interference level caused by external field and by the high-voltage transformer when magnetized at the full test voltage) is at least 6 dB and preferably 10 dB below the specified radio interference level of the surge arrester to be tested. Calibration methods for the measuring instrument are given in CISPR/TR 18-2.

As the radio interference level may be affected by fibres or dust settling on the insulators, it is permitted to wipe the insulators with a clean cloth before taking a measurement. The atmospheric conditions during the test shall be recorded. It is not known what correction factors apply to radio interference testing but it is known that test may be sensitive to high relative humidity and the results of test may be open to doubt if the relative humidity exceeds 80 %.

The following test procedure shall be followed.

The test voltage is increased to 1,15 U_C and then lowered to 1,05 U_C , where it shall be maintained for 5 min, U_C being the continuous operating voltage of the arrester. The voltage shall then be decreased by steps to 0,5 times U_C , raised again by steps to 1,05 U_C for 5 min and finally decreased by steps to 0,5 times U_C . At each step, a radio interference measurement shall be taken and the radio interference level, as recorded during the last series of voltage reductions, shall be plotted versus the applied voltage; the curve so obtained is the radio interference characteristic of the surge arrester. The amplitude of voltage steps shall be approximately 0,1 U_C .

The surge arrester shall have passed the test if the radio interference level at 1,05 times U_C and all lower voltage steps does not exceed 2 500 μV .

8.15 Test to verify the dielectric withstand of internal components

8.15.1 General

The purpose of this test is to verify the internal dielectric withstand capability of an arrester even under impulse currents of amplitudes higher than nominal discharge current.

If it can be demonstrated by calculations that, for a specific arrester, the electrical field at critical locations is less than or equal to the electrical field on an arrester which has been successfully tested at higher or equal voltage, no test is required. Additionally the test is required only if the conditioning part of the operating duty test (8.7.2.2) was not performed on a dielectrically prorated section.

The test shall be performed on one test sample.

The test sample shall be a dielectrically prorated section according to 7.3.2.2. No internal temperature sensor shall be installed.

8.15.2 Test procedure

The test sample shall be heated in an oven for a time sufficient to obtain thermal equilibrium to at least 60 °C. The test shall be performed within 10 minutes after removing the sample from the oven. The test consists of one application of a high-current impulse with amplitude according to Table 4.

Oscillograms of current and voltage shall be taken for the impulse application.

8.15.3 Test evaluation

The sample has passed the test if all the following criteria are met:

there is no evidence of a dielectric breakdown from the oscillograms;

any change of the residual voltage at nominal discharge current before and after the test is within $\pm 5\%$;

the following requirements are met

- if the manufacturer declares that the resistors may be removed from the test sample, a visual examination of the resistors shall be made and it shall be verified that the test has not caused puncture, flashover or cracking of the resistors.
- if the manufacturer declares that the MO resistors cannot be removed from the test sample, the following additional test shall be performed to be sure that no damage occurred during the test:
 - i) after the check of residual voltage at I_n , two current impulses 8/20 of an amplitude resulting in a current density of at least 0,5 kA/cm² or in 2 times I_n , whichever is lower, shall be applied to the sample. The first impulse shall be applied after sufficient time to allow the cooling of the sample to ambient temperature. The second impulse shall be applied between 50 s to 60 s after the first one. During the two impulses, the oscillograms of both voltage and current shall not reveal any breakdown.

8.16 Test of internal grading components

8.16.1 Test to verify long term stability under continuous operating voltage

If internal grading components such as capacitors or (non-linear) resistors are used in the arrester they shall be tested in an accelerated test to verify long term stability under continuous operating voltage under the same test conditions as the MO resistors (see 8.4.2.1). The test samples may be individual components or a stack of such components.

All material (solid or liquid) in direct contact with the grading components in the arrester shall be present during the ageing test with the same design as used in the complete arrester.

During the test, the test samples shall be placed in a temperature-controlled oven in the same surrounding medium as used in the arrester. The volume of the oven chamber shall be at least twice the volume of the test sample and the density of the medium in the chamber shall not be less than the density of the medium in the arrester.

NOTE The medium surrounding the grading components within the arrester may be subject to a modification during the normal life of the arrester due to internal partial discharges. Possible change of the medium surrounding the grading components in the field can significantly change their electrical properties.

A suitable test procedure taking into account such modifications is under consideration. During this time an alternative procedure consists in performing the test in N_2 or SF_6 (for GIS-arresters) with a low oxygen concentration (less than 0,1 % in volume). This ensures that even in the total absence of oxygen, the grading components will not age.

If the manufacturer can prove that the test carried out in the open air is equivalent to that carried out in the actual medium, the ageing procedure can be carried out in the open air.

Three samples shall be tested for 1 000 h, during which the temperature shall be controlled to keep the surface of the samples at $115\text{ °C} \pm 4\text{ K}$. During the 1 000 h test, the samples shall be energized at a voltage corresponding to the corrected maximum operating voltage (see 8.4.2.1) for the number of MO resistors installed in parallel to the grading components in the arrester. The impedance of the grading components shall be measured at $20\text{ °C} \pm 15\text{ K}$ before and after the 1 000 h test.

The samples shall have passed this part of the test if

- there is no evidence of a dielectric breakdown;
- examination after the test reveals no evidence of puncture, flashover or cracking of the grading components;
- a partial discharge test at the test voltage reveal partial discharges not exceeding 10 pC;
- the change in impedance of the grading components due to the 1 000 h test is not greater than $\pm 5\%$.

If the samples pass the above evaluation criteria, then MO resistors, equal in number to those used in parallel to the grading components in the arrester, shall be connected in parallel to the test sample, and two 8/20 lightning impulses with peak current density of $0,5\text{ kA/cm}^2$ in the MO resistors or 2 times I_n , whichever is lower, shall be applied to the sample. The first impulse shall be applied after sufficient time to allow the cooling of the sample to ambient temperature. The second impulse is applied between 50 s to 60 s after the first impulse. The impedance of the grading components shall be measured at $20\text{ °C} \pm 15\text{ K}$ before and after the two impulses. The samples shall have passed the test if

oscillograms of voltage and current taken during each impulse reveal no electrical breakdown the change in impedance of the grading components due to the two impulses is not greater than $\pm 5\%$.

8.16.2 Thermal cyclic test

Three samples shall be subjected to thermal variations without voltage applied. The thermal variations consist of five 48 h cycles of heating and cooling to 60 °C and -40 °C respectively. The hot and cold periods shall be maintained for at least 16 h. The test shall be conducted in air. The impedance of the grading components shall be measured at $20\text{ °C} \pm 15\text{ K}$ before and after the thermal cycles.

The samples have passed this part of the test if

- examination after the test reveals no evidence of cracking of the grading components;

- a partial discharge test at the test voltage corresponding to the corrected maximum operating voltage (8.4.2.1) for the number of MO resistors installed in parallel to the grading components in the arrester reveal partial discharges not exceeding 10 pC;
- the change in impedance of the grading components due to the thermal cycles is not greater than $\pm 5\%$.

If the samples pass the above evaluation criteria, then MO resistors, equal in number to those used in parallel to the grading components in the arrester, shall be connected in parallel to the test sample, and two 8/20 lightning impulses with peak current density of at least $0,5 \text{ kA/cm}^2$ in the MO resistors shall be applied to the sample. The first impulse shall be applied after sufficient time to allow the cooling of the sample to ambient temperature. The second impulse is applied between 50 s to 60 s after the first impulse. The impedance of the grading components shall be measured at $20 \text{ }^\circ\text{C} \pm 15 \text{ K}$ before and after the two impulses. The samples shall have passed the test if

- oscillograms of voltage and current taken during each impulse reveal no electrical breakdown;
- the change in impedance of the grading components due to the two impulses is not greater than $\pm 5\%$.

9 Routine tests and acceptance tests

9.1 Routine tests

The minimum requirement for routine tests to be made by the manufacturer shall be

- measurement of reference voltage, U_{ref} . The measured values shall be within a range specified by the manufacturer;
- residual voltage test. This test is compulsory for arresters with rated voltage above 1 kV. The test may be performed either on complete arresters, assembled arrester units or on a sample comprising one or several MO resistor elements. The manufacturer shall specify a suitable lightning current impulse in the range between 0,01 and 2 times the nominal current at which the residual voltage is measured. If not directly measured, the residual voltage of the complete arrester is taken as the sum of the residual voltages of the MO resistors or the individual arrester units. The residual voltage for the complete arrester shall not be higher than the value specified by the manufacturer.

NOTE 1 When 5 kA and 2,5 kA arresters below 36 kV rating are supplied in volume, the residual voltage test may be omitted in the routine tests if agreed between manufacturer and user.

- internal partial discharge test. This test shall be performed on each arrester unit. The test sample may be shielded against external partial discharges.
- The power-frequency voltage shall be increased to the rated voltage of the sample, held for 2 s to 10 s, and then decreased to 1,05 times the continuous operating voltage of the sample. At that voltage, the partial discharge level shall be measured according to IEC 60270. The measured value for the internal partial discharge shall not exceed 10 pC. Alternatively, the manufacturer may carry out the partial discharge measurement at the rated voltage or at a higher value without reducing the test voltage afterwards.
- In order to reduce test efforts during production, higher values of seal leak rate than required for type testing (see 8.13.4) may be used in this routine test for verification of correct assembly; for arrester units with an enclosed gas volume and separate sealing system, a leakage check shall be made on each unit by any sensitive method adopted by the manufacturer;
- current distribution test for multi-column arrester. This test shall be carried out on all groups of parallel MO resistors. A group of parallel MO resistors means a part of the assembly where no intermediate electrical connection between the columns is used. The manufacturer shall specify a suitable impulse current in the range 0,01 to 1 times the nominal discharge current at which the current through each column shall be measured. The highest current value shall not be higher than an upper limit specified by the

manufacturer. The current impulse shall have a virtual front time of not less than 7 μ s and the half-value time may have any value.

NOTE 2 If the rated voltage of the groups of parallel MO resistors used in the design is too high compared to available test facilities, the rated voltage of the group of parallel MO resistors used in this test can be reduced by introducing intermediate electrical connections between the columns, thereby establishing several artificial groups of parallel MO resistors. Each such artificial group will then pass the current distribution test specified.

- g) proper assembly of each disconnecter has to be demonstrated by either measurement of resistance / capacitance or partial discharges. The values of resistance or capacitance shall be in a range specified by the manufacturer. The measured value for the partial discharge shall not exceed 10 pC.

9.2 Acceptance tests

9.2.1 Standard acceptance tests

When the user specifies acceptance tests in the purchase agreement, the following tests shall be made on the nearest lower whole number to the cube root of the number of arresters to be supplied.

- a) Measurement of power-frequency voltage on the arrester at the reference current. The measured value shall be within a range specified by the manufacturer. For a multi-unit arrester, measurements may be made on individual units of the arrester. The reference voltage of the complete arrester is taken as the sum of the reference voltages of the individual arrester units.

- b) Lightning impulse residual voltage on the arrester at nominal discharge current if possible or at a current value chosen according to 8.3. In this case, the virtual time to half-value on the tail is less important and need not be complied with.

For a multi-unit arrester, measurements may be made on individual units of the arrester. The residual voltage of the complete arrester is taken as the sum of the residual voltages of the individual arrester units.

For GIS arresters, the residual voltage may be determined indirectly through measurement of reference voltage and demonstration (by tests on representative MO resistors) of the relationship between reference voltage and residual voltage.

The residual voltage for the complete arrester shall not be higher than a value specified by the manufacturer.

- c) Internal partial discharge test

The test shall be performed on the complete arrester or, for a multi-unit arrester, on the individual units of the arrester. The test sample may be shielded against external partial discharges.

The power-frequency voltage shall be increased to the rated voltage of the sample, held for 2 s to 10 s, and then decreased to 1,05 times the continuous operating voltage of the sample. At that voltage, the partial discharge level shall be measured according to IEC 60270. The measured value for the internal partial discharge shall not exceed 10 pC.

- d) On disconnectors used in combination with NGLA, bending moment and tensile load tests shall be performed. For each type of test (bending moment and tensile load), the load shall be increased smoothly to a load equivalent to 40 % of the rated strength specified by the manufacturer. The load shall be maintained at this level for 30 s. The test shall be considered successful if the following is demonstrated for each sample:

- no indication of mechanical damage;
- the slope of the force-deflection curve remains positive up to the test magnitude except for dips not exceeding 5 % of the test magnitude.
- A vibration test may also be performed with requirements agreed to between user and manufacturer.

Any alteration in the number of test samples or type of test shall be negotiated between the manufacturer and the user.

9.2.2 Special thermal stability test

The following test requires additional agreement between manufacturer and user prior to the commencement of arrester assembly (see 6.7).

This test shall be performed on three sections using MO resistors taken from current routine production and having the same dimensions and characteristics as those of the arresters under test. The test consists of the thermal recovery portion of the operating duty test (see 8.7.2.3).

MO resistor temperature or resistive component of current or power dissipation shall be monitored during the power frequency voltage application to prove thermal stability. The test is passed if thermal stability occurs in all three samples (see 8.7.2.4). If one sample fails, agreement shall be reached between the manufacturer and the user regarding any further tests.

10 Test requirements on polymer-housed surge arresters

Clauses 1 to 5 and Clause 7 apply in their entirety to polymer-housed arresters. Many of the requirements in Clause 6 and many of the tests prescribed in Clause 8 also apply without change to polymer-housed arresters. Where there is a variation, of any degree, from the requirements of Clauses 6 and 8, that variation is provided here for polymer-housed arresters.

10.1 Scope

Clause 1 applies without modification.

10.2 Normative references

Clause 2 applies without modification.

10.3 Terms and definitions

Clause 3 applies without modification.

10.4 Identification and classification

Clause 4 applies without modification.

10.5 Standard ratings and service conditions

Clause 5 applies without modification.

10.6 Requirements

Clause 6 applies except as follows:

10.6.13 Short-circuit performance

Replacement of Subclause 6.13:

The manufacturer shall declare a short-circuit current rating for each family of arresters. Only for applications with expected short-circuit currents below 1 kA the rated value “zero” may be claimed. In this case “0” shall be indicated on the name plate. In any case, the arrester shall be subjected to a short-circuit test according to 10.8.10 to show that it will not fail in a manner

that causes violent shattering of the housing and that self-extinguishing of open flames (if any) occurs within a defined period of time.

10.6.16.2 Bending moment

Replacement of Subclause 6.16.2:

The arrester shall be able to withstand the manufacturer's declared values for bending loads (see 10.8.11).

NOTE 1 Forces other than those applied by physical connections might affect the mechanical loading of an arrester; for example: wind, ice and electromagnetic forces.

NOTE 2 Unlike porcelain housed arresters, polymer-housed arresters might show mechanical deflections in service

Surge arresters enclosed within their package should withstand the transportation loads specified by the user in accordance with IEC 60721-3-2, but not less than Class 2M1.

10.6.16.4 Insulating base

Replacement of Subclause 6.16.4:

When an arrester is fitted with an insulating base, this device shall withstand the following test without any damage, which could affect its normal function:

- test of the bending moment (see 8.11.6).

10.6.16.5

Subclause 6.16.5 does not apply.

10.7 General testing procedure

Clause 7 applies without modification.

10.8 Type tests (design tests)

10.8.1 General

Amendment:

Type tests shall be performed as defined in Clause 8, except for specific changes indicated below (list numbers refer to numbers in rows of Table 3):

- 11) Environmental tests do not apply
- 16) Artificial pollution tests of Annex C do not apply.

In addition, the following test is to be made for polymer-housed arresters intended for outdoor use

- 17) Weather ageing test (see 10.8.17)

10.8.2 Insulation withstand tests

Subclause 8.2 applies without modification.

10.8.3 Residual voltage tests

Subclause 8.3 applies without modification.

10.8.4 Test to verify long term stability under continuous operating voltage

Subclause 8.4 applies without modification.

10.8.5 Test to verify the repetitive charge transfer rating, Q_{rs}

Subclause 8.5 applies without modification.

10.8.6 Heat dissipation behaviour of test sample

Subclause 8.6 applies without modification.

10.8.7 Operating duty tests

Subclause 8.7 applies, except as follows:

10.8.7.2.4 Test evaluation

Replacement of Subclause 8.7.2.4:

The test shall be considered passed if all the following criteria are met:

thermal recovery has been demonstrated;

any change of the residual voltage at nominal discharge current before and after the test is within $\pm 5\%$;

the following requirements are met:

- if the manufacturer declares that the resistors may be removed from the test sample, a visual examination of the resistors shall be made and it shall be verified that the test has not caused puncture, flashover or cracking of the resistors.
- if the manufacturer declares that the MO resistors cannot be removed from the test sample for visual examination, the following additional test shall be performed to be sure that no damage occurred during the test:
 - i) after the check of residual voltage at I_n , two further current impulses 8/20 at I_n shall be applied to the sample. The first impulse shall be applied after sufficient time to allow the cooling of the sample to ambient temperature. The second impulse shall be applied between 50 s to 60 s after the first one. During the two impulses, the oscillograms of both voltage and current shall not reveal any breakdown. The variation of the residual voltage between the initial measurement and the last impulse shall not be greater than $\pm 5\%$.

10.8.8 Power frequency voltage-versus-time test

Subclause 8.8 applies, except as follows:

10.8.8.5 Test evaluation

Replacement of Subclause 8.8.5:

A sample shall be considered passed if all the following criteria are met:

thermal recovery has been demonstrated;

any change of the residual voltage at nominal discharge current before and after the test is within $\pm 5\%$.

the following requirements are met:

- if the manufacturer declares that the resistors may be removed from the test sample, a visual examination of the resistors shall be made and it shall be verified that the test has not caused puncture, flashover or cracking of the resistors.

- If the manufacturer declares that the MO resistors cannot be removed from the test sample for visual examination, the following additional test shall be performed to be sure that no damage occurred during the test:
 - i) after the check of residual voltage at I_n , two current impulses 8/20 of an amplitude resulting in a current density of at least 0,5 kA/cm² or in 2 times I_n , whichever is lower, shall be applied to the sample. The first impulse shall be applied after sufficient time to allow the cooling of the sample to ambient temperature. The second impulse shall be applied between 50 s to 60 s after the first one. During the two impulses, the oscillograms of both voltage and current shall not reveal any breakdown.

The manufacturer's published curve has been verified when all six samples have been tested at TOV voltages and corresponding durations that are equal to or greater than the values indicated on the curve, and all samples have passed the evaluation criteria. All test points shall be displayed on the curve.

10.8.9 Tests of arrester disconnecter

Subclause 8.9 applies without modification.

10.8.10 Short-circuit tests

Subclause 8.10 applies, except as follows:

10.8.10.2 Preparation of the test samples

Replacement of Subclause 8.10.2:

Depending on the type of arrester and test voltage, different requirements apply with regard to the number of test samples, initiation of short-circuit current and amplitude of the first short-circuit current peak. Table 8 shows a summary of these requirements which are further explained in the following subclauses.

For the high-current tests, the test samples shall be the longest arrester unit used for the design with the highest rated voltage of that unit used for each different arrester design.

For the low-current test, the test sample shall be an arrester unit of any length with the highest rated voltage of that unit used for each different arrester design. Figure 5 shows different examples of arrester units.

10.8.10.2.3 "Design B" arresters

Replacement of Subclause 8.10.2.3:

No special preparation is necessary. Standard arrester units shall be used. The arrester units shall be electrically pre-failed with a power frequency overvoltage. The overvoltage shall be run on completely assembled test units. No physical modification shall be made to the units between pre-failing and the actual short-circuit current test.

The overvoltage given by the manufacturer shall be a voltage exceeding 1,15 times U_C . The voltage shall cause the arrester to fail within (5 ± 3) min. The MO resistors are considered to have failed when the voltage across the MO resistors falls below 10 % of the originally applied voltage. The short-circuit current of the pre-failing test circuit shall not exceed 30 A.

The time between pre-failure and the rated short-circuit current test shall not exceed 15 min.

The pre-failure can be achieved by either applying a voltage source or a current source to the samples.

Voltage source method: the initial current should typically be in the range 5-10 mA/cm². The short-circuit current should typically be between 1 A and 30 A. The voltage source need not be adjusted after the initial setting, although small adjustments might be necessary in order to fail the MO resistors in the given time range.

Current source method: Typically a current density of around 15 mA/cm² with a variation of $\pm 50\%$, will result in failure of the MO resistors in the given time range. The short-circuit current should typically be between 10 A and 30 A. The current source need not be adjusted after the initial setting, although small adjustments might be necessary in order to fail the MO resistors in the given time range.

Table 8 – Test requirements for polymer-housed arresters

		Ratio of first current peak value to r.m.s. value of required short-circuit current taken from Table 7					
		Test voltage: 77 % to 107 % of U_r			Test voltage: < 77 % of U_r		
		Rated short-circuit current	Reduced short-circuit current	Low short-circuit current	Rated short-circuit current	Reduced short-circuit current	Low short-circuit current
"Design A"	4 or 5	Fuse wire along surface of MO resistors; within, or as close as possible to, the gas channel	Prospective: $\geq 2,5$ Actual: no requirement	Prospective: $\geq \sqrt{2}$ Actual: no requirement	Actual: $\geq \sqrt{2}$	Actual: $\geq 2,5$ or: Actual: $\geq \sqrt{2}$ on longest unit and Actual: $\geq 2,5$ on a unit with $U_r \geq 150$ kV	Actual: $\geq \sqrt{2}$
"Design B"	4	Pre-failing by constant voltage or constant current source	Prospective: $\geq \sqrt{2}$ Actual: no requirement	Prospective: $\geq \sqrt{2}$ Actual: no requirement	Actual: $\geq \sqrt{2}$	Actual: $\geq \sqrt{2}$	Actual: $\geq \sqrt{2}$

10.8.10.3 Mounting of the test sample

Replacement of Subclause 8.10.3:

For a base-mounted arrester, the mounting arrangement is shown in Figure 9. The distance to the ground from the insulating platform and the conductors shall be as indicated in this figure.

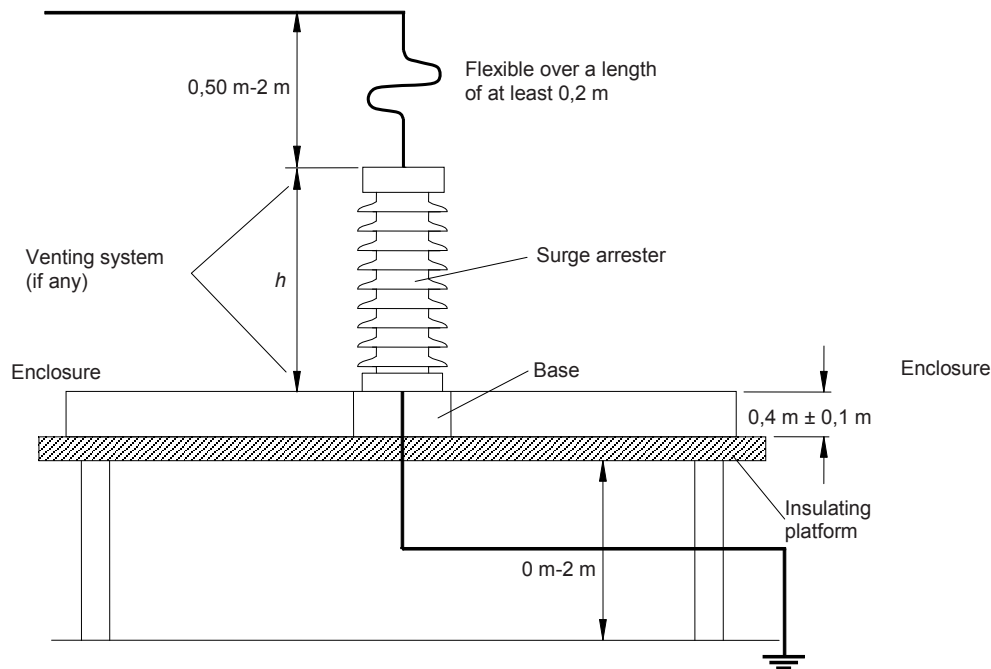

IEC 1962/14

NOTE All leads and venting systems in the same plane.

Figure 9 – Short-circuit test setup for polymer-housed arresters

For non-base-mounted arresters (for example, pole-mounted arresters), the test sample shall be mounted on a non-metallic pole using mounting brackets and hardware typically used for real service installation. For the purpose of the test, the mounting bracket shall be considered as a part of the arrester base. In cases where the foregoing is at variance with the manufacturer's instructions, the arrester shall be mounted in accordance with the installation recommendations of the manufacturer. The entire lead between the base and the current sensor shall be insulated for at least 1 000 V. The top end of the test sample shall be fitted with the base assembly of the same design of an arrester or with the top cap.

For base-mounted arresters, the bottom end fitting of the test sample shall be mounted on a test base that is at the same height as a surrounding circular or square enclosure. The test base shall be of insulating material or may be of conducting material if its surface dimensions are smaller than the surface dimensions of the arrester bottom end fitting. The test base and the enclosure shall be placed on top of an insulating platform, as shown in Figure 9. For non-base-mounted arresters, the same requirements apply to the bottom of the arrester. The arcing distance between the top end cap and any other metallic object (floating or grounded), except for the base of the arrester, shall be at least 1,6 times the height of the sample arrester, but not less than 0,9 m. The enclosure shall be made of non-metallic material and be positioned symmetrically with respect to the axis of the test sample. The height of the enclosure shall be 40 cm ± 10 cm, and its diameter (or side, in case of a square enclosure) shall be equal to the greater of 1,8 m or D in Equation (1) below. The enclosure shall not be permitted to open or move during the test.

$$D = 1,2 \times (2 \times H + D_{arr}) \quad (1)$$

where

- H is the height of tested arrester unit;
 D_{arr} is the diameter of tested arrester unit.

In the event that physical space limitations of the laboratory do not permit an enclosure of the specified size, the manufacturer may choose to use an enclosure of lesser diameter.

Test samples shall be mounted vertically unless agreed upon otherwise between the manufacturer and the user.

The mounting of the arrester during the short-circuit test and, more specifically, the routing of the conductors shall represent the most unfavourable condition in service. For all polymer-housed arresters, the ground conductor shall be directed to the opposite direction as the incoming conductor, as described in Figure 9. In this way, the arc will stay close to the arrester during the entire duration of the short-circuit current, thus creating the most unfavourable conditions with regards to the fire hazard.

10.8.10.4.3 High-current test at less than 77 % of rated voltage

Replacement of Subclause 8.10.4.3:

When tests are made with a test circuit voltage <77 % of the rated voltage of the test samples, the test circuit parameters shall be adjusted in such a way that the r.m.s. value of the symmetrical component of the actual arrester test current shall equal or exceed the required test current level selected from Table 7.

For “Design A” arresters tested at the rated short-circuit current, the peak value of the first half-cycle of the actual arrester test current shall be at least 2,5 times the r.m.s. value of the rated short circuit current selected from Table 7. The following r.m.s. value of the symmetrical component shall be equal to the rated short-circuit current or higher. The peak value of the actual arrester test current, divided by 2,5 shall be quoted as the test current, even though the r.m.s. value of the symmetrical component of the actual arrester test current may be higher.

The following exception for the test at rated short-circuit current is valid for “Design A” polymer-housed arresters only: if the rated voltage of the test sample is more than 150 kV and a first peak value of $\geq 2,5$ times the rated short-circuit current cannot be achieved, an additional test sample shall be tested. This additional test sample shall be tested according to either 8.10.4.2 or 8.10.4.3. It shall have a rated voltage of ≥ 150 kV and shall also not be shorter than the shortest arrester unit used for the actual arrester design. The rated short-circuit current value shall be the lowest of the r.m.s. current from the test on the longest unit and the r.m.s. current defined according to testing with either 8.10.2.2 or 10.8.10.2.2 from the test on the minimum 150 kV rated unit. Both tests shall be reported.

For “Design B” arresters tested at rated short-circuit current, the peak value of the first half-cycle of the actual arrester test current shall be at least $\sqrt{2}$ times the r.m.s. value of the rated short circuit current.

For all the reduced short-circuit currents the r.m.s. value shall be in accordance with Table 7 and the peak value of the first half-cycle of the actual arrester test current shall be at least $\sqrt{2}$ times the r.m.s. value of this current.

Especially for tall arresters that are tested at a low percentage of their rated voltage, the first asymmetric peak current of 2,5 is not easily achieved unless special test possibilities are considered. It is thus possible to increase the test r.m.s voltage or reduce the impedance so that, for the rated short-circuit current, the peak value of the first half-cycle of the test current is equal to, or greater than, 2,5 times the required test current level. In case of testing with a

generator, the first peak of 2,5 times the required test current can also be achieved by varying the generator's excitation. The current should then be reduced, not less than 2,5 cycles after initiation, to the required symmetrical value. The actual peak value of the test current, divided by 2,5, should be quoted as the test current, even though the r.m.s. value of the symmetrical component of the actual arrester test current may be higher. Because of the higher test current, the sample arrester may be subjected to more severe duty and, therefore, tests at X/R ratio lower than 15 should only be carried out with the manufacturer's consent.

For "Design B" polymer-housed arresters, even the first current peak of $\sqrt{2}$ may not be easily achieved unless special test facilities are considered. Pre-failed arresters can build up considerable arc resistance, which limits the symmetrical current through the arrester. It is therefore recommended to perform the short-circuit tests as soon as possible after the pre-failure, preferably before the test samples have cooled down.

For pre-failed arresters, therefore, it is recommended to ensure that the arrester represents a sufficiently low impedance prior to applying the short-circuit current by reapplying the pre-failing, or similar, circuit during a maximum of 2 s immediately before applying the short-circuit test current (see Figure 10). It is acceptable to increase the short-circuit current of the pre-applied circuit up to 300 A (r.m.s.). If so, its maximum duration, which depends on the current magnitude, shall not exceed the following value:

$$t_{\text{rpf}} \leq Q_{\text{rpf}} / I_{\text{rpf}}$$

where

- t_{rpf} is the re-pre-failing time in s;
- Q_{rpf} is the re-pre-failing charge = 60 As;
- I_{rpf} is the re-pre-failing current in A (r.m.s.).

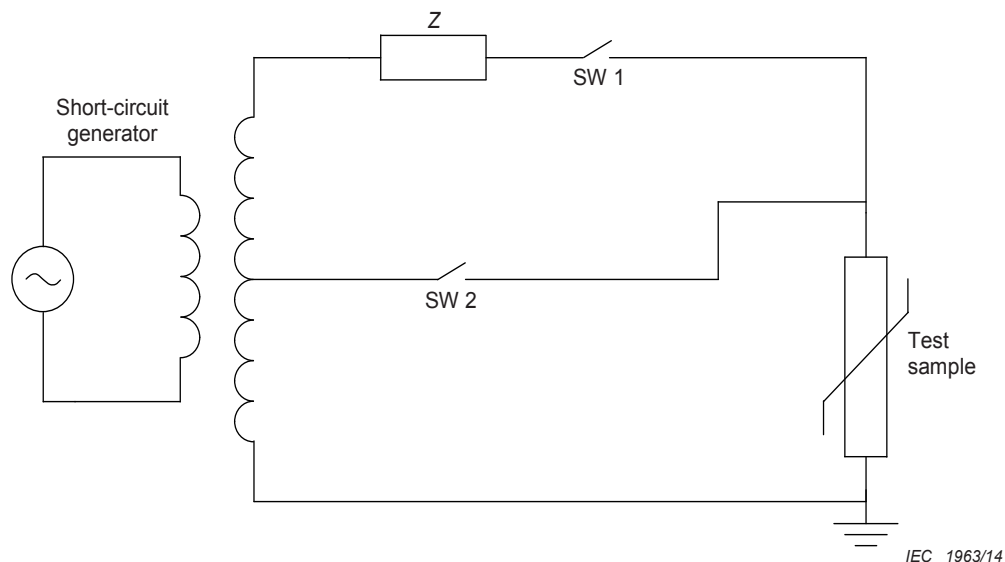

NOTE SW 1 is closed and SW 2 is opened to apply pre-failing level of current (maximum of 30 A, limited by impedance Z). After a maximum of 2 s, SW 2 is closed to cause the specified short-circuit current to flow through the test sample.

Figure 10 – Example of a test circuit for re-applying pre-failing circuit immediately before applying the short-circuit test current

10.8.11 Test of the bending moment

Replacement of Subclause 8.11:

This test applies to polymer (except cast-resin) housed arresters (with and without enclosed gas volume) for $U_s > 52$ kV. It also applies to polymer (except cast-resin) housed arresters for $U_s \leq 52$ kV for which the manufacturer claims cantilever strength. The test shall be performed on the arrester without insulating base or mounting bracket.

Cast-resin housed arresters shall be tested according to 8.11. Arresters that have no declared cantilever strength shall be submitted to the terminal torque preconditioning according to 10.8.12.3.1.1, the thermal preconditioning according to 10.8.11.3.1.3 and the water immersion test according to 10.8.11.3.2.

The complete test procedure is shown by the flow chart in Annex G.

10.8.11.1 General

This test demonstrates the ability of the arrester to withstand the manufacturer's declared values for bending loads. Normally, an arrester is not designed for torsional loading. If an arrester is subjected to torsional loads, a specific test may be necessary by agreement between manufacturer and user.

The test shall be performed on complete arrester units with the highest rated voltage of the unit. For single-unit arrester designs, the test shall be performed on the longest unit with the highest rated voltage of that unit of the design. Where an arrester contains more than one unit or where the arrester has different specified bending moments in both ends, the test shall be performed on the longest unit of each different specified bending moment, with loads determined according to M.1. However, if the length of the longest unit is greater than 800 mm, a shorter length unit may be used, provided the following requirements are met:

the length is at least as long as the greater of

- 800 mm
- three times the outside diameter of the housing (excluding the sheds) at the point it enters the end fittings;

the unit is one of the normal assortment of units used in the design, and is not specially made for the test;

the unit has the highest rated voltage of that unit of the design.

A test in three steps (two steps for arresters for $U_s \leq 52$ kV) shall be performed one after the other on three samples as follows:

on all three test samples a cyclic test comprising 1 000 cycles with the test load equal to the specified long-term load (SLL);

on two of the samples a static bending moment test with the test load equal to the specified short-term load (SSL), i.e. the 100 % value of G.3 and on the 3rd sample a mechanical preconditioning test as per 10.8.11.3.1;

on all three samples a water immersion test as per 10.8.11.3.2.

Tolerance on specified loads shall be $\begin{matrix} +5 \\ -0 \end{matrix}$ %.

NOTE The cyclic test is not required for arresters for $U_s \leq 52$ kV.

10.8.11.2 Sample preparation

The test samples shall contain the internal parts.

Prior to the test, each test sample shall be subjected to the following tests:

- electrical tests made in the following sequence:

watt losses measured at U_c and at an ambient temperature of $20\text{ °C} \pm 15\text{ K}$;

internal partial discharge test according to item c) of 9.1;

residual voltage test at (0,01 to 1) times the nominal discharge current; the current wave shape shall be in the range of $T_1/T_2 = (4\text{ to }10)/(10\text{ to }25)\text{ }\mu\text{s}$;

- leakage tests in accordance with item d) of 9.1 for arresters with enclosed gas volume and separate sealing system.

If the partial discharge test according to item c) of 9.1 and the leakage test according to item d) of 9.1 have been performed as routine tests they need not be repeated at this time.

One end of the sample shall be firmly fixed to a rigid mounting surface of the test equipment, and a load shall be applied to the other (free) end of the sample to produce the required bending moment at the fixed end. The direction of the load shall pass through and be perpendicular to the longitudinal axis of the arrester. If the arrester is not axi-symmetrical with respect to its bending strength, the manufacturer shall provide information regarding this non-symmetric strength, and the load shall be applied in an angular direction that subjects the weakest part of the arrester to the maximum bending moment.

10.8.11.3 Test procedure

The test shall be performed on three samples. For arresters for $U_s > 52\text{ kV}$, the test is performed in three steps. For arresters for $U_s \leq 52\text{ kV}$, the test is performed in two steps.

a) Arresters for $U_s > 52\text{ kV}$

Step 1:

Subject all three samples to 1 000 cycles of bending moment, each cycle comprising loading from zero to specified long-term load (SLL) in one direction, followed by loading to SLL in the opposite direction, then returning to zero load. The cyclic motion shall be approximately sinusoidal in form, with a frequency in the range 0,01 Hz – 0,5 Hz.

Due to the control of the testing machine it may take some cycles to obtain the SLL. The maximum number of these cycles shall be specified by the manufacturer. These cycles shall not be included in the prescribed 1 000 cycles.

The maximum deflection during the test and any residual deflection shall be recorded. The residual deflection shall be measured in the interval 1 min to 10 min after the release of the load.

Step 2.1:

Subject two of the samples from step 1 to a bending moment test. The bending load shall be increased smoothly to specified short-term load (SSL) within 30 s to 90 s. When the test load is reached, it shall be maintained for 60 s to 90 s. During this time the deflection shall be measured. Then the load shall be released smoothly.

The maximum deflection during the test and residual deflection shall be recorded. The residual deflection shall be measured within 1 min to 10 min after the release of the load.

Step 2.2:

Subject the third sample from Step 1 to mechanical/thermal preconditioning according to 10.8.11.3.1.

Step 3:

Subject all three samples to the water immersion test according to 10.8.11.3.2.

b) Arresters for $U_s \leq 52\text{ kV}$

Step 1.1:

Subject two samples to a bending moment test. The bending load shall be increased smoothly to specified short-term load (SSL) within 30 s to 90 s. When the test load is reached, it shall be maintained for 60 s to 90 s. During this time the deflection shall be measured. Then the load shall be released smoothly.

The maximum deflection during the test and any residual deflection shall be recorded. The residual deflection shall be measured in the interval 1 min to 10 min after the release of the load.

Step 1.2:

Subject a third sample to mechanical/thermal preconditioning according to 10.8.11.3.1.

Step 2:

Subject all three samples to the water immersion test according to 10.8.11.3.2.

10.8.11.3.1 Mechanical/thermal preconditioning

This preconditioning constitutes part of the test procedure of 10.8.11.3 and shall be performed on one of the test samples as defined in 10.8.11.3.

10.8.11.3.1.1 Terminal torque preconditioning

The arrester terminal torque specified by the manufacturer shall be applied to the test sample for a duration of 30 s.

10.8.11.3.1.2 Thermo-mechanical preconditioning

This portion of the test applies only to arresters for which a cantilever strength is declared.

The sample is submitted to the specified long-term load (SLL) in four directions and in thermal variations as described in Figure 11 and Figure 12.

If, in particular applications, other loads are dominant, the relevant loads shall be applied instead. The total test time and temperature cycle shall remain unchanged.

The thermal variations consist of two 48 h cycles of heating and cooling as described in Figure 11. The temperature shall be measured in the air surrounding the arrester in the test chamber. The temperature of the hot and cold periods shall be maintained for at least 16 h. The test shall be conducted in air.

The applied static mechanical load shall be equal to SLL defined by the manufacturer. Its direction changes every 24 h at any temperature in the transition from hot to cold, or from cold to hot, as defined in Figure 12.

The test may be interrupted for maintenance for a total duration of 4 h and restarted after interruption. The cycle then remains valid.

Any residual deflection measured from the initial no-load position shall be reported. The residual deflection shall be measured within 1 min to 10 min after the release of the load.

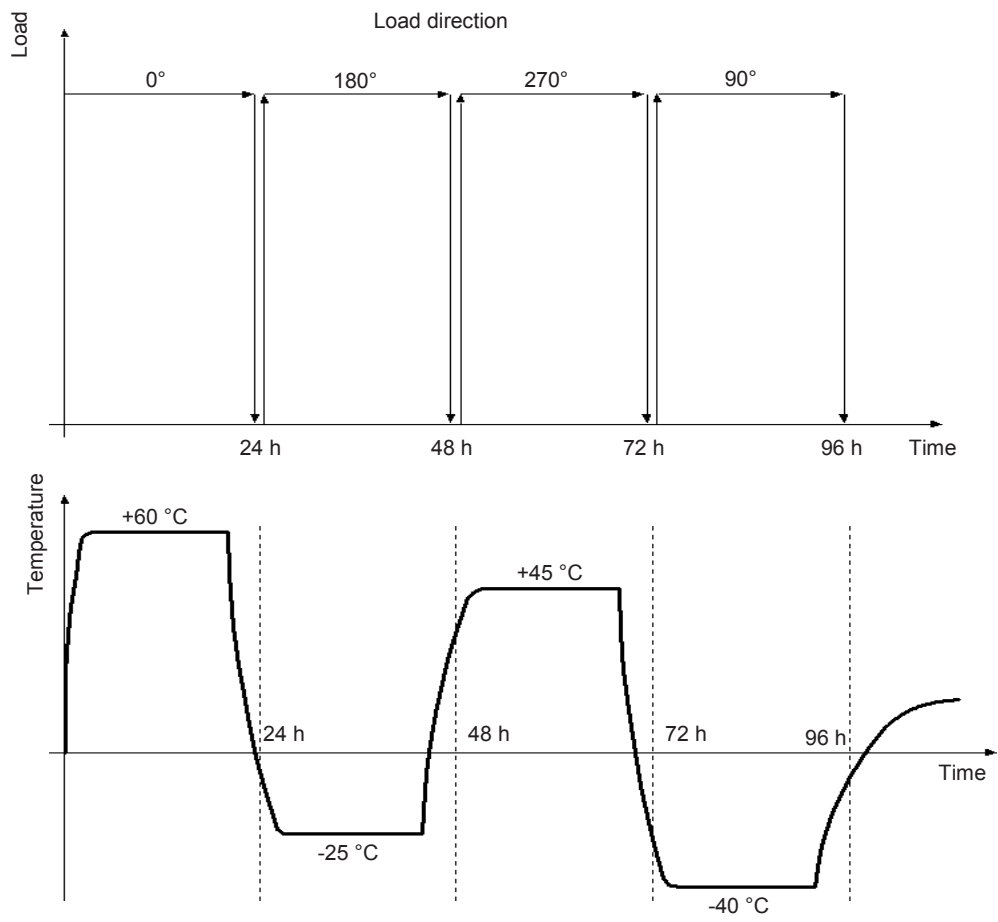

IEC 1964/14

Figure 11 – Thermomechanical test

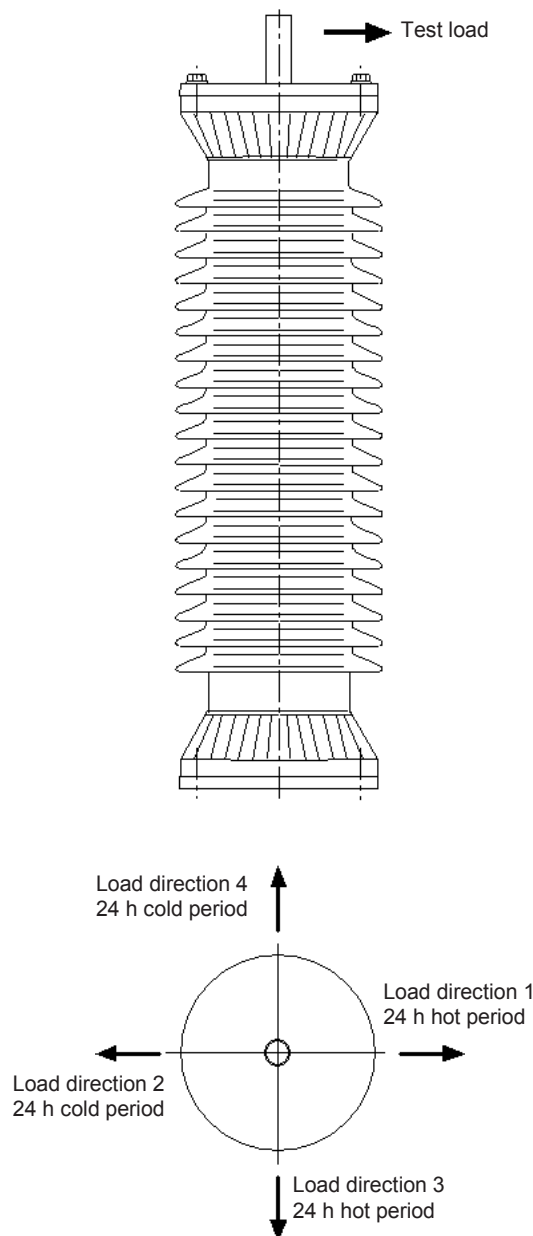

IEC 1965/14

Figure 12 – Example of the test arrangement for the thermomechanical test and direction of the cantilever load

10.8.11.3.1.3 Thermal preconditioning

This portion of the test applies only to arresters for which no cantilever strength is declared.

The sample is submitted to the thermal variations as described in Figure 11 without any load applied.

The thermal variations consist of two 48 h cycles of heating and cooling as described in Figure 11. The temperature of the hot and cold periods shall be maintained for at least 16 h. The test shall be conducted in air.

10.8.11.3.2 Water immersion test

The test samples shall be kept immersed in a vessel, in boiling deionised water with 1 kg/m³ of NaCl, for 42 h.

NOTE 1 The characteristics of the water described above are those measured at the beginning of the test.

NOTE 2 This temperature (boiling water) can be reduced to 80 °C (with a minimum duration of 52 h) by agreement between the user and the manufacturer, if the manufacturer claims that its sealing material is not able to withstand the boiling temperature for a duration of 42 h. This value of 52 h can be expanded up to 168 h (i.e. one week) after agreement between the manufacturer and the user.

At the end of the boiling, the arrester shall remain in the vessel until the water cools to approximately 50 °C and shall be maintained in the water at this temperature until verification tests can be performed. The arrester shall be removed from the water and cooled to ambient temperature for not longer than three thermal time constants of the sample (as derived from the cooling curves of 10.8.6). The 50 °C holding temperature is necessary only if it is necessary to delay the verification tests after the end of the water immersion test as shown in Figure 13. Evaluation tests shall be made within the time specified in 10.8.11.4. After removing the sample from the water it may be washed with tap water.

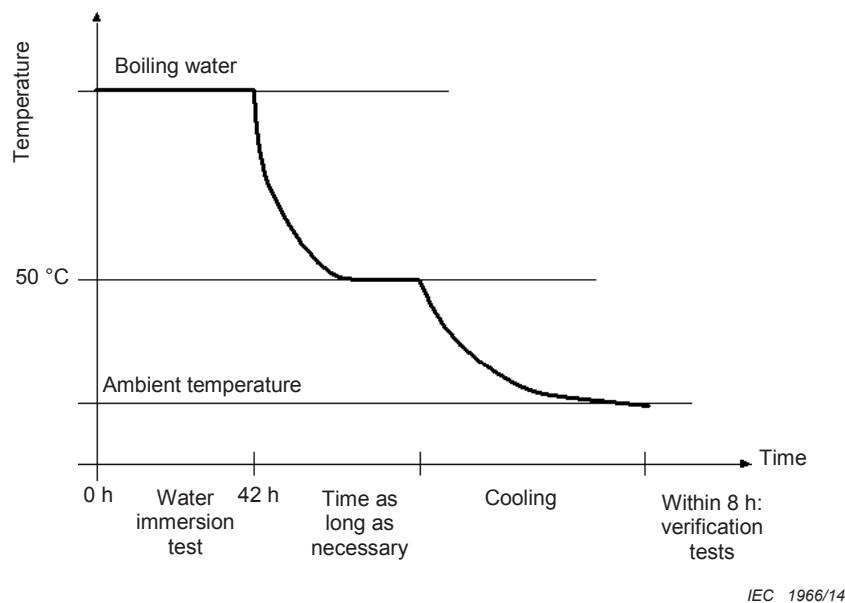

Figure 13 – Water immersion

10.8.11.4 Test evaluation

Tests according to 10.8.12.2 shall be repeated on each test sample.

The arrester shall have passed the test if the following is demonstrated:

a) Arresters for $U_s > 52$ kV

After step 2:

there is no visible damage;

the slope of the force-deflection curve remains positive up to the SSL value except for dips not exceeding 5 % of SSL magnitude. The sampling rate of digital measuring equipment shall be at least 10 s^{-1} . The cut-off frequency of the measuring equipment shall be not less than 5 Hz.

Maximum deflection during step 1 and 2 and any remaining permanent deflection after the test shall be reported.

After step 3:

within 8 h after cooling as defined in Figure 13:

- the increase in watt losses, measured at U_c and at an ambient temperature that does not deviate by more than 3 K from the initial measurements, is not more than the greater of 20 mW/kV of U_c (measured at U_c) or 20 %;
- the internal partial discharge measured at 1,05 times U_c does not exceed 10 pC;

at any time after the above watt losses and partial discharge measurements:

- for arresters with enclosed gas volume and separate sealing system, the samples pass the leakage test in accordance with item d) of 9.1;
- the residual voltage measured on the complete sample at the same current value and wave shape as the initial measurement is not more than 5 % different from the initial measurement;
- the difference in voltage between two successive impulses at nominal discharge current does not exceed 2 %, and the oscillograms of voltage and current do not reveal any partial or full breakdown of the test sample. The current wave shape shall be in the range of $T_1/T_2 = (4 \text{ to } 10)/(10 \text{ to } 25) \mu\text{s}$, and the impulses shall be administered 50 to 60 s apart.
- the change in reference voltage measured before and after the two residual voltage tests does not exceed 2 %.

NOTE 1 In case of extra-long arresters where the blocks can be dismantled this part of the evaluation test can be performed on individual blocks or stacks of blocks. If the blocks cannot be dismantled a possible procedure would be to drill a hole in the arrester insulation to make contact with the internal stack at a metal spacer and in this way be able to test shorter arrester sections.

b) Arresters for $U_s \leq 52 \text{ kV}$

After step 1:

there is no visible damage;

for step 1.1, the slope of the force-deflection curve remains positive up to the SSL value except for dips not exceeding 5 % of SSL magnitude. The sampling rate of digital measuring equipment shall be at least 10 s^{-1} . The cut-off frequency of the measuring equipment shall be not less than 5 Hz.

Maximum deflection during step 1 and any remaining permanent deflection after the test shall be reported.

After step 2:

within 8 h after cooling as defined in Figure 13:

- the increase in watt losses, measured at U_c and at an ambient temperature that does not deviate by more than 3 K from the initial measurements, is not more than the greater of 20 mW/kV of U_c (measured at U_c) or 20 %;
- the internal partial discharge measured at 1,05 times U_c does not exceed 10 pC;

at any time after the above watt losses and partial discharge measurements:

- for arresters with enclosed gas volume and separate sealing system, the samples pass the leakage test in accordance with item d) of 9.1;
- the residual voltage measured at the same current value and wave shape as the initial measurement is not more than 5 % different from the initial measurement;
- the difference in voltage between two successive impulses at nominal discharge current does not exceed 2 %, and the oscillograms of voltage and current do not reveal any partial or full breakdown of the test sample. The current wave shape shall be in the range of $T_1/T_2 = (4 \text{ to } 10)/(10 \text{ to } 25) \mu\text{s}$ and the impulses shall be administered 50 to 60 s apart.
- the change in reference voltage measured before and after the two residual voltage tests does not exceed 2 %.

NOTE 2 In case of extra-long arresters where the blocks can be dismantled, the residual voltage test can be performed on individual blocks or stacks of blocks. If the blocks cannot be dismantled, a possible procedure would be to drill a hole in the arrester insulation to make contact with the internal stack at a metal spacer and in this way be able to test shorter arrester sections.

10.8.12 Environmental tests

Subclause 8.12 does not apply.

10.8.13 Seal leak rate test

Subclause 8.13 applies, except as follows:

10.8.13.1 General

Replacement of Subclause 8.13.1:

This test applies to arresters having an enclosed gas volume and a separate sealing system. The test demonstrates the gas/water tightness of the complete system. It applies to arresters with polymer housings having seals and associated components essential for maintaining a controlled atmosphere within the housing (arresters with enclosed gas volume and a separate sealing system).

The test shall be performed on one complete arrester unit. The internal parts may be omitted. If the arrester contains units with differences in their sealing system, the test shall be performed on one unit each, representing each different sealing system.

10.8.14 Radio interference voltage (RIV) test

Subclause 8.14 applies without modification.

10.8.15 Test to verify the dielectric withstand of internal components

Subclause 8.15 applies without modification.

10.8.16 Test of internal grading components

Subclause 8.16 applies without modification.

Addition:

10.8.17 Weather ageing test

10.8.17.1 General

This test has two parts. One evaluates the effect of exposure of the arrester to salt fog. The other evaluates the effect of exposure of the housing material to ultra-violet (UV) light.

10.8.17.2 Salt fog test

10.8.17.2.1 Test specimens

This test shall be performed on the longest electrical unit with the minimum specific creepage distance and the highest rated voltage recommended by the manufacturer for this unit.

10.8.17.2.2 Test procedure

The test is a time-limited continuous test under salt fog at constant power-frequency voltage equal to U_c . The test is carried out in a moisture-sealed corrosion-proof chamber. An aperture of not more than 80 cm² shall be provided for the natural evacuation of exhaust air. A turbo sprayer or room humidifier of constant spraying capacity shall be used as a water atomizer.

The fog shall fill up the chamber and not be directly sprayed onto the test specimen. The salt water prepared with NaCl and deionized water will be supplied to the sprayer. The power-

frequency test voltage shall be obtained with a test transformer. The test circuit, when loaded with a resistive current of 250 mA (r.m.s.) during 1 s on the high-voltage side, shall experience a maximum voltage drop of 5 %.

The protection level shall be set at 1 A (r.m.s.). The test specimen shall be cleaned with deionized water before starting the test.

The test specimen shall be tested when mounted vertically. There shall be enough clearance between the roof and walls of the chamber and the test specimen in order to avoid electrical field disturbance. These data shall be found in the manufacturer's installation instructions.

Duration of the test	1 000 h
Water flow rate	0,4 l/h/m ³ ± 0,1 l/h/m ³
Size of droplets	5 µm to 10 µm
Temperature	20 °C ± 5 K
NaCl content of water	between 1 kg/m ³ to 10 kg/m ³

The manufacturer shall state the starting value of the salt content of the water. The water flow rate is defined in litres per hour per cubic metre of the test chamber. It is not permitted to recirculate the water. Interruptions due to flashovers are permitted. If more than one flashover occurs, the test voltage is interrupted. However, the salt fog application shall continue until the washing of the arrester with tap water is started. Interruptions of salt fog application shall not exceed 15 min. The test shall then be re-started at a lower value of the salt content of the water. If again more than one flashover occurs, this procedure shall be repeated. Interruption times shall not be counted as part of the test duration.

The NaCl content of the water, the number of flashovers and the duration of the interruptions shall be noted. The number of overcurrent trip-outs shall be noted and taken into account in the evaluation of the duration of the test.

NOTE Within this range of salinity, lower salt content may increase test severity. Higher salt content increases flashover probability, which makes it difficult to run the test on larger diameter housings.

10.8.17.2.3 Evaluation of the test

The test is regarded as passed, if no tracking occurs (see IEC 62217), if erosion does not occur through the entire thickness of any shed or other part of the external coating up to the next layer of material, if the sheds and housing are not punctured, if the reference voltage measured before and after the test at the same ambient temperature within ± 3 K has not decreased by more than 5 %, and if the partial discharge measurement performed before and after the test is satisfactory, i.e. the partial discharge level shall not exceed 10 pC as measured according to the procedure of 9.1 c).

10.8.17.3 UV light test

10.8.17.3.1 Test procedure

Select three specimens of shed and housing materials for this test (with markings included, if applicable). The insulator housing material shall be subjected to a 1 000 h UV light test using one of the following test methods. Markings on the housing, if any, shall be directly exposed to UV light:

- Xenon-arc methods: ISO 4892-1 and ISO 4892-2, using method A without dark periods, standard spray cycle, black-standard/black panel temperatures of 65 °C, an irradiance of around 550 W/m²
- Fluorescent UV method: ISO 4892-1 and ISO 4892-3, using type I fluorescent UV lamp, exposure method 1 or 2.

NOTE A revision of the UV test is currently under consideration by CIGRÉ WG D1.14.

10.8.17.3.2 Evaluation of the test

After the test, markings on shed or housing material shall be legible; surface degradations such as cracks and raised areas are not permitted. In case of doubt concerning such degradation, two surface roughness measurements shall be made on each of the three specimens. The roughness, R_z as defined in ISO 4287, shall be measured along a sampling length of at least 2,5 mm. R_z shall not exceed 0,1 mm.

NOTE ISO 3274 gives details of surface roughness measurement instruments.

10.9 Routine tests

Clause 9 applies without modification.

11 Test requirements on gas-insulated metal enclosed arresters (GIS-arresters)

Clauses 1, 2, 5 and 7 apply in their entirety to gas-insulated metal enclosed arresters (GIS-arresters). Many of the requirements in Clauses 3, 4 and 6 and many of the tests prescribed in Clauses 8 and 9 also apply without change to gas-insulated metal enclosed arresters (GIS-arresters). Where there is a variation, of any degree, from the requirements of Clauses 3, 4, 6, 8 and 9, that variation is provided here for gas-insulated metal enclosed arresters (GIS-arresters).

11.1 Scope

Clause 1 applies without modification.

11.2 Normative references

Clause 2 applies without modification.

11.3 Terms and definitions

Clause 3 applies except for the following:

11.3.26

Replacement of Subclause 3.26:

3.26 housing of a GIS arrester

external metallic enclosure of the arrester, which is connected to earth and which protects the internal parts from the environment

11.4 Identification and classification

Clause 4 applies except as follows:

11.4.1

Replacement of Subclause 4.1:

Metal-oxide surge arresters shall be identified by the following minimum information which shall appear on a nameplate permanently attached to the arrester:

continuous operating voltage;

rated voltage;

rated frequency, if other than one of the standard frequencies (see 5.2);

nominal discharge current;

rated short-circuit current in kiloamperes (kA). For arresters for which no short-circuit rating is claimed, the sign "–" shall be indicated;

the manufacturer's name or trade mark, type and identification of the complete arrester;

identification of the assembling position of the unit (for multi-unit arresters only);

the year of manufacture;

serial number (at least for arresters with rated voltage above 60 kV)

rated gas pressure for insulation at 20 °C.

If sufficient space is available the nameplate should also contain

repetitive charge transfer rating, Q_{RS} ;

contamination withstand level of the enclosure (see IEC TS 60815-1).

11.5 Standard ratings and service conditions

Clause 5 applies without modification.

11.6 Requirements

Clause 6 applies except as follows:

11.6.1 Withstand voltages

Replacement of Subclause 6.1:

a) Single-phase arrester

The insulation between the internal parts and the metal housing shall withstand the following voltages when tested according to 11.8.2.

- The lightning impulse withstand voltage of the equipment to be protected or the lightning impulse protection level of the arrester multiplied by 1,3 whichever is lower.

NOTE 1 The 1,3 factor covers discharge currents higher than nominal. Variations in atmospheric conditions, as given for porcelain-housed arresters, are not relevant for GIS-arresters. Nevertheless, the factor of 1,3 is retained to provide additional security.

- For 10 kA and 20 kA arresters intended for use on systems of $U_s \leq 245$ kV, the switching impulse withstand voltage of the equipment to be protected or the switching impulse protection level of the arrester multiplied by 1,25, whichever is lower.

NOTE 2 The 1,25 factor covers discharge currents higher than normal. Variations in atmospheric conditions, as given for porcelain-housed arresters, are not relevant for GIS-arresters. Nevertheless, the factor 1,25 is retained to provide additional security.

- For 10 kA and 20 kA arresters intended for use on systems of $U_s \leq 245$ kV, the power-frequency withstand voltage of the equipment to be protected or a power-frequency voltage with a peak value equal to the switching impulse protection level multiplied by 1,2 for a duration of 1 min, whichever is lower.
- For 2,5 kA and 5 kA arresters, a power-frequency withstand voltage of the equipment to be protected or a power-frequency voltage with a peak value equal to the lightning impulse protection level for a duration of 1 min, whichever is lower.

b) Three-phase arrester

The withstand voltage for the insulation of three-phase arresters is given in Table 9 and Table 10.

Table 10 – 2,5 kA and 5 kA three – phase – GIS arresters – Required withstand voltages

Type of withstand voltage	Test	Comment
Lightning impulse withstand voltage	Phase-to-earth and phase-to-phase: – withstand voltage of equipment to be protected (see IEC 60071-1) or – phase-to-earth: $1,3 \times$ lightning impulse protection level – phase-to-phase: $1,3 \times$ lightning impulse protection level + $U_c \times \sqrt{2}$	Whichever is lower
Power-frequency withstand voltage	Phase-to-earth and phase-to-phase: – withstand voltage of equipment to be protected (see IEC 60071-1) or – phase-to-earth: U_{ac} = lightning impulse protection level – phase-to-phase: $U_{ac} =$ lightning impulse protection level + $U_c \times \sqrt{2}$	Whichever is lower

11.6.13 Short-circuit performance

Replacement of Subclause 6.13:

The design of the metallic enclosures of GIS-arresters shall meet the requirements of 5.103 of IEC 62271-203:2011 or 5.102 of IEC 62271-200:2011. If this is fulfilled and the enclosure of the surge arrester is fitted with the same pressure-relief device as the connected switchgear, no short-circuit test according to 8.10 is required.

If the arrester has a separate internal enclosure with a pressure-relief device different from that of the metallic vessel, 8.10 applies. In this case, it is necessary that a test be performed only with the rated short-circuit current.

11.6.14 Disconnecter

Subclause 6.14 does not apply.

11.6.15 Requirements on internal grading components

Subclause 6.15 does not apply.

11.7 General testing procedures

Clause 7 applies without modification.

11.8 Type tests (design tests)

11.8.1 General

Amendment:

Type tests shall be performed as defined in Clause 8, except for specific changes indicated below (list numbers refer to numbers in rows of Table 3):

- 1) Insulation withstand tests – see 11.8.2.
- 6) Operating duty test – see 11.8.7.
- 8) Tests of arrester disconnecter – does not apply.
- 9) Short-circuit tests – see 11.8.10.
- 10) Test of the bending moment – does not apply.
- 11) Environmental tests – does not apply.
- 12) Seal leak rate test – does not apply.
- 16) Polluted housing test – does not apply.

11.8.2 Insulation withstand tests

Replacement of Subclause 8.2:

11.8.2.1 General

These tests demonstrate the ability of the insulation to withstand the required voltage stresses between the internal parts and the metal housing and, in addition, between the phases for a three-phase arrester.

The insulation withstand tests shall also assure that all internal components are tested at least to the equivalent of the highest stresses in service. A separate test of single

components may therefore be necessary to verify the required withstand voltage (see 11.8.2.5).

For single-phase arresters, the test shall be performed on the complete arrester with the MO resistors replaced by insulating parts. Grading elements may be used instead of insulating parts in order to control the voltage distribution along the arrester axis.

In the case of a three-phase arrester, the phase(s) not energized during the test shall be connected to earth. For active parts connected to a voltage source, the MO resistors shall be replaced by insulating parts. Grading elements may be used instead of insulating parts in order to control the voltage distribution along the arrester axis.

NOTE Due to the strong influence of earth capacitances in GIS arresters, it may be difficult or even impossible to achieve a linear voltage distribution by grading elements. Performing the test with an uneven voltage distribution or without any grading elements represents the worst case, and test results remain conservative.

During the tests, the insulating gas shall have the minimum functional density specified for the arrester.

11.8.2.2 Lightning impulse voltage test

The arresters shall be subjected to a standard lightning impulse voltage according to IEC 60060-1.

a) Single-phase arresters

The test voltage shall be as specified in 11.6.1.

Fifteen consecutive impulses at the test voltage value shall be applied for each polarity. The arrester has passed the test if no disruptive discharges occur. In the case of disruptive discharges, the pass criteria in 6.2.4 of IEC 62271-1:2007 shall be observed.

b) Three-phase arrester

The test voltage shall be as specified in 11.6.1.

The test shall start with the phase-to-earth insulation test. The test voltage is applied to one phase, while the other phases are connected to earth.

After the phase-to-earth insulation test, the phase-to-phase insulation test shall be performed. This test can be made using only an impulse voltage or an impulse voltage and a power frequency voltage. The choice is made by the manufacturer.

- If the test is made using only an impulse voltage, the same test arrangement as used for the phase-to-earth test shall be used.
- If the test is made using an impulse voltage and a power-frequency voltage, only one phase is connected to earth. The impulse voltage is applied to the second phase, while the power-frequency voltage is applied to the third phase in such a way that, during application of the impulse voltage to the second phase, the power-frequency voltage reaches its peak value of the opposite polarity.

The phase-to-earth test and the phase-to-phase test shall be repeated for all possible combinations of the three active parts, unless proved unnecessary by considerations of electrical symmetry.

In both tests, 15 consecutive impulses at the test voltage value shall be applied for each polarity. The arrester has passed the test if no disruptive discharges occur. In the case of disruptive discharges, the pass criteria in 6.2.4 of IEC 62271-1:2013 shall be observed.

11.8.2.3 Switching impulse voltage test

The arresters shall be subjected to a standard switching impulse voltage according to IEC 60060-1.

a) Single-phase arresters

The test voltage shall be as specified in 11.6.1.

Fifteen consecutive impulses at the test voltage value shall be applied for each polarity. The arrester has passed the test if no disruptive discharges occur. In case of disruptive discharges, the pass criteria in 6.2.4 of IEC 62271-1:2013 shall be observed.

b) Three-phase arresters

The test voltage shall be as specified in 11.6.1.

The tests shall start with the phase-to-earth insulation test. The test voltage is applied to one phase, while the other two phases are connected to earth.

After this test, the phase-to-phase insulation test may be performed, without changing the test arrangement, by increasing the test voltage to the required level.

If flashovers occur or are expected, one of the following two test alternatives shall be adopted. The choice is made by the manufacturer:

- One phase of the arrester is earthed. Two switching impulses of equal amplitude and opposite polarity shall be applied to the two other phases. The impulses shall reach their crests at the same instant. The amplitude of each impulse shall be half the required switching impulse withstand voltage phase-to-phase (phase-to-phase test according to IEC 60071-1).
- One phase of the arrester is earthed. A switching impulse equal to the required value phase-to-earth is applied to the second phase. A power-frequency voltage is applied to the third phase such that the crest of the switching impulse is reached at the power-frequency voltage peak of opposite polarity. The difference between the voltages at the instant of the switching impulse crest shall be equal to the required switching impulse withstand voltage phase-to-phase (longitudinal insulation test according to IEC 60071-1).

The phase-to-earth test and the phase-to-phase test shall be repeated for all possible combinations of three active parts, unless proved unnecessary by considerations of electrical symmetry.

In both tests, 15 consecutive impulses at the test voltage value shall be applied for each polarity. The arrester has passed the test if no disruptive discharge occurs. In case of disruptive discharges, the pass criteria in IEC 62271-203 and IEC 62271-200 shall be observed.

11.8.2.4 Power-frequency voltage test

a) Single-phase arresters

The test voltage shall be as specified in 11.6.1.

The arrester has passed the test if no disruptive discharge occurs.

b) Three-phase arresters

The test voltage shall be as specified in 11.6.1.

The tests shall start with the phase-to-earth insulation test. The test voltage is applied to one phase, while the other phases are connected to earth.

After the phase-to-earth insulation test, the phase-to-phase insulation test shall be performed. If this test is made using only a power-frequency voltage, the same test arrangement shall be taken. The applied voltage shall be raised to the required phase-to-phase value.

The arrester has passed the test if no disruptive discharge occurs.

Alternatively, the following test procedure may be adopted. One phase of the arrester is connected to earth. The impulse voltage equal to 1,2 times the switching impulse protection level is applied to the second phase, while the power-frequency voltage equal to U_c is applied to the third phase. This is done in such a way that, during application of the impulse voltage to the second phase, the power-frequency voltage reaches its peak value of the opposite polarity.

The phase-to-earth test and the phase-to-phase test shall be repeated for all possible combinations of the three active parts, unless proved unnecessary by considerations of electrical symmetry.

Fifteen consecutive impulses at the test voltage shall be applied to each polarity. The arrester has passed the test if no disruptive discharge occurs. In case of disruptive discharges, the pass criteria in IEC 62271-203 and IEC 62271-200 shall be observed.

11.8.2.5 Withstand test on the active part of GIS-arresters

For a GIS-arrester with an active part containing the MO resistor elements electrically connected in series but geometrically arranged in parallel by using insulating material, the voltage withstand capability of the insulating material, the resistance of the supporting structure and the insulation between the MO resistor columns shall be tested.

The test shall be performed in such a way that all possible voltage stresses mentioned above are taken into consideration.

During the test, the samples may be surrounded by the actual gas of a density corresponding to the minimum density specified for the complete arrester.

11.8.3 Residual voltage tests

Subclause 8.3 applies without modification.

11.8.4 Test to verify long term stability under continuous operating voltage

Subclause 8.4 applies without modification.

11.8.5 Test to verify the repetitive charge transfer rating, Q_{rs}

Subclause 8.5 applies without modification.

11.8.6 Heat dissipation behaviour of test sample

Subclause 8.6 applies without modification.

11.8.7 Operating duty tests

Subclause 8.7 applies without modification.

11.8.8 Power frequency voltage-versus-time test

Subclause 8.8 applies without modification.

11.8.9 Tests of arrester disconnecter

Subclause 8.9 does not apply.

11.8.10 Short-circuit tests

Addition:

Subclause 8.10 applies if the arrester has a separate internal enclosure with a pressure-relief device different from that of the metallic vessel. Otherwise, see 0 for test requirements.

11.8.11 Test of the bending moment

Subclause 8.11 does not apply.

11.8.12 Environmental tests

Subclause 8.12 does not apply.

11.8.13 Seal leak rate test

Subclause 8.13 does not apply.

11.8.14 Radio interference voltage (RIV) test

Subclause 8.14 applies without modification.

11.8.15 Test to verify the dielectric withstand of internal components

Subclause 8.15 applies without modification.

11.8.16 Test of internal grading components

Subclause 8.16 applies without modification.

11.9 Routine tests

Addition:

The routine tests on GIS-arresters shall be carried out according to 9.1.

The reference voltage shall be measured on the complete arrester or on the active parts of the arrester.

The partial discharge test shall be performed on the complete arrester or on the active parts of the arrester and on the arrester housing, including supporting structure and grading elements.

Addition:

11.10 Test after erection on site

If the arrester is delivered incompletely assembled to the site, it shall be checked for correct mounting by any appropriate method adopted by the manufacturer.

If the insulating capacity of gas-insulated switchgear equipped with arresters is to be tested with impulse or power-frequency voltages, the arresters shall be removed or rendered inoperative to permit these tests.

12 Separable and dead-front arresters

Clauses 2, 4, 7 and 9 apply in their entirety to separable and dead-front arresters. Many of the requirements in Clauses 3, 5 and 6 and many of the tests prescribed in Clause 8 also apply without change to separable and dead-front arresters. Where there is a variation, of any degree, from the requirements of Clauses 3, 5, 6 and 8, that variation is provided here for separable and dead-front arresters.

12.1 Scope

Replacement of Clause 1:

This clause applies to arresters designed with insulating and/or screened/shielded housings providing system insulation, intended to be installed in an enclosure for the protection of distribution equipment and circuits.

12.2 Normative references

Clause 2 applies without modification.

12.3 Terms and definitions

Clause 3 applies, except as follows:

Replacement of Subclause 3.26:

12.3.26 housing of a separable or a dead-front arrester

- a) for separable arrester: external enclosure of the arrester, insulated or screened/shielded by electrically conducting material, which protects the internal parts from the environment
- b) for dead-front arrester: external enclosure of the arrester, screened/shielded by metallic or electrically conducting polymeric material, which is connected to earth and which protects the internal parts from the environment

12.4 Identification and classification

Clause 4 applies without modification.

12.5 Standard ratings and service conditions

Clause 5 applies, except as follows:

12.5.4 Normal service conditions

Replacement of Subclause 5.4:

Surge arresters which conform to this standard shall be suitable for normal operation under the following normal service conditions.

- a) Ambient air temperature in the general vicinity of dead-front arresters shall be between $-40\text{ }^{\circ}\text{C}$ and $+65\text{ }^{\circ}\text{C}$.
- b) The maximum temperature of dead-front arresters due to self-heating and external heat sources in the general vicinity of the arrester shall not exceed $+85\text{ }^{\circ}\text{C}$.

NOTE The effects of maximum solar radiation ($1,1\text{ kW/m}^2$) have been taken into account by preheating the test specimen in the type tests. Other heat sources that may affect the application of the arrester are not considered under normal service condition.

- c) Altitude not exceeding 1 000 m.
- d) Frequency of the a.c. power supply not less than 48 Hz and not exceeding 62 Hz.
- e) Power-frequency voltage applied continuously between the terminals of the arrester not exceeding its continuous operating voltage.
- f) Mechanical conditions (under consideration).
- g) Pollution conditions (no requirement at this time).

12.6 Requirements

Clause 6 applies except as follows:

12.6.4 Internal partial discharges

Under normal and dry operating conditions, Internal partial discharges shall be below a level that might cause damage to internal parts. This shall be demonstrated by test according to 12.8.17.

12.6.13 Short-circuit performance

Replacement of Subclause 6.13:

An arrester shall not fail in a manner that causes violent shattering (see 12.8.10). The manufacturer shall declare a short-circuit current rating for each family of arresters. Only for applications with expected short-circuit currents below 1 kA the rated value “zero” may be claimed. In this case “0” shall be indicated on the name plate.

All separable and dead-front arresters shall be able to withstand MO resistor failures without ejecting arrester parts through the body of the housing except at places specifically designed for this purpose.

12.7 General testing procedure

Clause 7 applies without modification.

12.8 Type tests (design tests)

12.8.1 General

Amendment:

Type tests shall be performed as defined in Clause 8, except for specific changes indicated below (list numbers refer to numbers in rows of Table 3):

- 1) Insulation withstand tests – see 12.8.2.
- 8) Tests of arrester disconnectors – does not apply.
- 9) Short-circuit tests – see 12.8.10.
- 10) Test of the bending moment – does not apply.
- 11) Environmental tests – does not apply.
- 12) Seal leak rate test – does not apply.
- 16) Polluted housing test – does not apply.

In addition, the following test is to be made:

- 17) Internal partial discharge test (see 12.8.17)

12.8.2 Insulation withstand tests

Subclause 8.2 applies with the following additions:

Addition:

12.8.2.9 Insulation withstand tests of unscreened separable arresters

For unscreened separable arresters where the clearances are smaller than those specified in IEC 60071-2, three samples shall be mounted in an earthed test terminal box, as shown in Figure 14. Provided that the test box is symmetrical, the test shall be performed on arresters 1 and 2. If the box is not symmetrical, all three arresters shall be tested. The minimum allowable clearances *a*, *b*, *c*, *d*, and *e* shall be stated in the literature included with the arrester. For screened separable arresters, a single-phase test is sufficient.

The insulation withstand tests may be carried out with arresters including the MO resistors. In this case, the tested unit shall be isolated from earth potential. During the impulse test, the arrester next to the tested arrester shall be earthed.

Insulation withstand values shall be in accordance with Table 11.

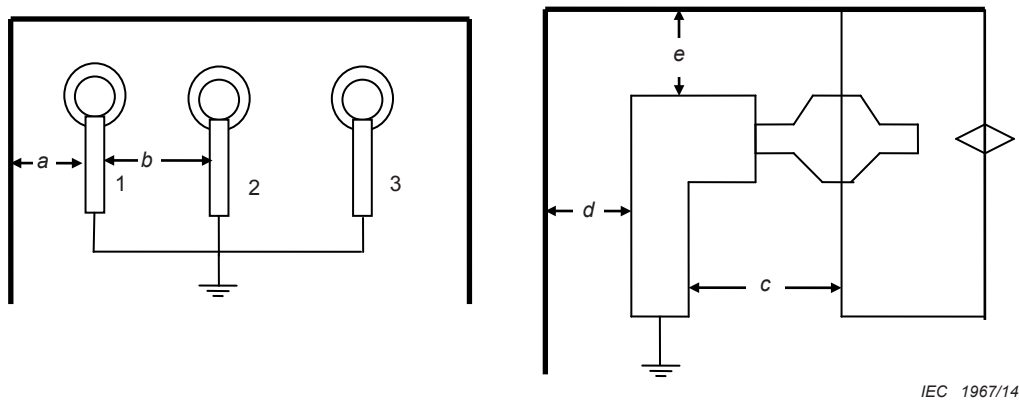

Figure 14 – Test set-up for insulation withstand test of unscreened separable arresters

Table 11 – Insulation withstand test voltages for unscreened separable arresters

U_s kV	Impulse test 1,2/50 full wave kV (peak value)	50/60 Hz test voltage kV (r.m.s.)
12	75	28
17,5	95	38
24	125	50
36	170	70

NOTE Test values are in accordance with IEC 62271-1 and IEC 60071-1 and, for other values of the "highest voltage for equipment", use the test voltages in IEC 60071-1.

12.8.2.10 Insulation withstand tests of dead-front or separable arresters in a screened/shielded housing

For dead-front or separable arresters in a screened/shielded housing, the MO resistors shall be removed and replaced by a metal rod of the same outer diameter as the MO resistors. The length of the metal rod shall be at least two-thirds of the total length of the MO resistor stack. The lower end of the rod shall be shaped in such a way as to minimize dielectric stress (for example, semi-spherical). To isolate the housing screen/shield at the lower end, the remaining housing length shall be filled with insulating material (solid or liquid) to prevent interfacial breakdown during the test. The high-voltage terminal shall be energized and the screened/shielded housing earthed for the test.

Insulation withstand values shall be in accordance with Table 11 or Table 12, depending on the intended application.

Table 12 – Insulation withstand test voltages for dead-front arresters or separable arresters in a screened/shielded housing

System class rating kV	Impulse test 1,2/50 full wave kV (peak)	50/60 Hz test voltage kV (r.m.s.) applied for 1 min	DC test voltage kV applied for 15 min
15	95	34	53
25	125	40	78
35	150	50	103

NOTE Test values are in accordance with IEEE C62.11.

12.8.3 Residual voltage tests

Subclause 8.3 applies without modification.

12.8.4 Test to verify long term stability under continuous operating voltage

Subclause 8.4 applies, except as follows:

12.8.4.1 Test procedure

Replacement of Subclause 8.4.2.1:

This test shall be performed on three typical samples of MO resistor elements with a reference voltage fulfilling the requirements of 7.3. The power frequency voltage shall fulfil the requirements stated for the operating duty test (see 8.7.1).

All material (solid or liquid) in direct contact with the MO resistors in the arrester shall be present during the ageing test with the same design as used in the complete arrester.

During the test, the MO resistors shall be placed in a temperature-controlled oven in the same surrounding medium as used in the arrester. The volume of the oven chamber shall be at least twice the volume of the MO resistor and the density of the medium in the chamber shall not be less than the density of the medium in the arrester.

NOTE 1 The medium surrounding the MO resistor within the arrester may be subject to a modification during the normal life of the arrester due to internal partial discharges. Possible change of the medium surrounding the MO resistor in the field can significantly increase the power losses.

A suitable test procedure taking into account such modifications is under consideration. During this time an alternative procedure consists in performing the test in N_2 or SF_6 (for GIS-arresters) with a low oxygen concentration (less than 0,1 % in volume). This ensures that even in the total absence of oxygen, the arrester will not age.

If the manufacturer can prove that the test carried out in the open air is equivalent to that carried out in the actual medium, the ageing procedure can be carried out in the open air.

The MO resistors shall be heated to $115\text{ °C} \pm 4\text{ K}$ and the MO resistor power losses P_{start} shall be measured at the corrected maximum continuous operating voltage of U_{ct} (see below) $3\text{ h} \pm 5\text{ min}$ after the voltage application. The samples shall be maintained at this voltage for 1 000 h for separable arresters and for 2 000 h for dead-front arresters, during which the oven temperature shall be controlled to keep the surface temperature of the MO resistor at $115\text{ °C} \pm 4\text{ K}$.

The MO resistor power losses shall be measured at U_{ct} once in every 100 h after the first measurement, and a final measurement, P_{end} , shall be made after $1\,000^{+100}_0$ h of ageing for separable arresters or after $2\,000^{+100}_0$ h of ageing for dead-front arresters.

Accidental intermediate de-energizing of the test samples, not exceeding a total duration of 24 h during the test period is permissible. The interruption will not be counted in the duration of the test. The final measurement should be performed after not less than 100 h of continuous energizing. Within the temperature range allowed, all measurements shall be made at the same temperature ± 1 K.

The relevant voltage for this procedure is the corrected maximum continuous operating voltage (U_{ct}), which the MO resistors support in the arrester including voltage unbalance effects. This voltage shall be determined by voltage distribution measurements or computations.

NOTE 2 Information on procedures for voltage distribution calculations are given in Annex F.

Only for unscreened separable arresters with a length H of less than 1 m the voltage may be determined from the following formula:

$$U_{ct} = U_c (1 + 0,15 H)$$

where H is the total length of the arrester (m).

12.8.5 Test to verify the repetitive charge transfer rating, Q_{rs}

Subclause 8.5 applies without modification.

12.8.6 Heat dissipation behaviour of test sample

Subclause 8.6 applies without modification.

12.8.7 Operating duty tests

Subclause 8.7 applies, except as follows:

12.8.7.2.3 Thermal recovery test

Replacement of Subclause 8.7.2.3:

The following procedure shall be applied for the thermal recovery part of the test:

The complete test samples shall be preheated to a temperature of at least the start temperature as follows:

- for unscreened separable arresters: start temperature = 60 °C

for screened separable and dead-front arresters: start temperature = 85 °C

The preheating shall take not more than twenty hours.

The temperature of the MO resistors shall be at least the start temperature immediately prior to the injection of energy or transfer of charge.

Each sample shall be subjected to injection of energy or transfer of charge, administered in the form of two 8/20 lightning current impulses within one minute, having a sufficient magnitude that the accumulated charge is at least equal to the claimed thermal charge transfer rating selected from the list given in Table 5.

Within 100 ms from the energy or charge application, a voltage equal to the rated voltage U_r shall be applied for 10 s and thereafter a voltage equal to the continuous operating voltage U_c (if necessary further adjusted as per 7.3) shall be applied for a minimum of 30 minutes to demonstrate thermal stability. Resistive component of current or power dissipation or temperature or any combination of them shall be monitored until the measured value is appreciably reduced (success), but for at least 30 minutes, or thermal runaway condition (failure) is evident.

12.8.8 Power-frequency voltage versus time test

Subclause 8.8 applies without modification.

12.8.9 Tests of disconnecter

Subclause 8.9 does not apply.

12.8.10 Short-circuit test

Amendment:

All arresters shall be subjected to a short-circuit test according to 8.10 to show that the arrester will not fail in a manner that causes violent shattering of the housing. Modifications to 8.10 that are applicable to separable and dead-front arresters are as follows.

NOTE Revised short-circuit test procedures for separable and dead-front arresters are under consideration.

12.8.10.1 General

Replacement of Subclause 8.10.1:

All arresters shall be tested. The test is conducted to show that an arrester failure is not likely to cause an explosive failure.

Each arrester design is tested with two groups of short-circuit currents according to Table 7:

high short-circuit current values consisting of the rated short-circuit current and two reduced short-circuit currents if applicable;

low short-circuit current.

NOTE There are two principal designs with respect to short-circuit behaviour.

One design of surge arresters makes use of the internal overpressure, which is built up due to the internal arc coming from the short circuit of the arrester elements. The overpressure is created by heating an enclosed volume of gas or liquid, which expands, leading to bursting or flipping of a pressure-relief device (in this case, the tests are sometimes called "pressure-relief tests"). The arrester housing is not intended to break before the overpressure is relieved.

Another design, usually of a compact type with no enclosed volume of gas or liquid, does not have any pressure-relief device. The short-circuit performance of this design depends on the arc directly burning through or tearing the housing.

If the arrester is equipped with an arrangement other than a conventional pressure relief device, this arrangement should be included in the test.

For the rated and reduced short-circuit current, the methods of test sample preparation depend upon the arrester construction. For an arrester fitted with a pressure-relief device, the active MO resistors are externally bypassed by a fuse wire. For an arrester without a pressure-relief device, the active MO resistors may be pre-failed by overvoltage or may be bypassed with an internal fuse wire installed in a drilled hole through the MO resistors.

For the low-current short-circuit test, active MO resistors are pre-failed by overvoltage.

The frequency of the short-circuit current test supply should be not less than 48 Hz and not greater than 62 Hz.

Upon agreement between the manufacturer and the user, reclosing cycle tests may be performed using a mutually agreed upon test procedure and test criteria.

All separable and dead-front arresters shall be able to withstand MO resistor failures without ejecting arrester parts through the body of the housing except at places specifically designed for this purpose. The tests shall be made on the highest voltage rating of complete arrester units of a given type and design. These tests shall be considered to substantiate conformance to this standard of lower voltage ratings of the same type and design.

Samples shall be prepared according to 8.10.2 or 10.8.10.2 as appropriate for the design

12.8.10.3 Mounting of the test sample

Replacement of Subclause 8.10.3:

Dead-front arrester test specimens shall be mounted on a standard interface bushing to simulate normal service conditions.

Separable arrester short-circuit tests shall be carried out while installed in the individual compartment. Mounting shall be in accordance with 10.2.3 of IEC 62271:2006.

12.8.10.6 Evaluation of test results

Replacement of Subclause 8.10.6:

Fracture of the housing with ejection of arrester parts through the body shall constitute failure of the arrester to pass this test. Ejection of arrester parts including MO resistors through the bottom with release of the bottom cap, or through other parts specifically designed for this purpose, is acceptable.

The arrester shall be able to self-extinguish open flames within 2 min after the end of the test. Any ejected part (in or out of the enclosure) must also self-extinguish open flames within 2 min.

NOTE This behaviour might strongly differ from that of AIS arresters. Manufacturers can be consulted about special installation recommendations.

12.8.11 Test of the bending moment

Subclause 8.11 does not apply.

12.8.12 Environmental tests

Subclause 8.12 does not apply.

12.8.13 Seal leak rate test

Subclause 8.13 does not apply.

12.8.14 Radio interference voltage (RIV) test

Subclause 8.14 applies without modification.

12.8.15 Test to verify the dielectric withstand of internal components

Subclause 8.15 applies without modification.

12.8.16 Test of internal grading components

Subclause 8.16 applies without modification.

Addition:

12.8.17 Internal partial discharge test

The test shall be performed on the longest electrical unit of the arrester. If this does not represent the highest specific voltage stress per unit length, additional tests shall be performed on the unit having the highest specific voltage stress. The test sample may be shielded against external partial discharges.

NOTE Shielding against external partial discharges should have negligible effects on the voltage distribution.

Test voltages and extinction levels shall be according to Table 13.

Table 13 – Partial discharge test values for separable and dead-front arresters

Separable arresters		Dead-front arresters	
U_s	Partial discharge test voltage (extinction level)	System class rating	Partial discharge test voltage (extinction level)
kV	kV (r.m.s.) ^a	kV	kV (r.m.s.)
12	12	15	11
17,5	17,5	25	19
24	24	35	26
36	36	-	-

^a If U_C is lower than the highest voltage of equipment, the test voltage shall be 1,05 times U_C .

12.9 Routine tests and acceptance tests

Clause 9 applies without modification.

13 Liquid-immersed arresters

Clauses 2, 4, 7 and 9 apply in their entirety to liquid-immersed arresters. Many of the requirements in Clauses 3, 5 and 6 and many of the tests prescribed in Clause 8 also apply without change to liquid-immersed arresters. Where there is a variation, of any degree, from the requirements of Clauses 3, 5, 6 and 8, that variation is provided here for liquid-immersed arresters.

13.1 Scope

Replacement:

This clause applies to arresters designed to be used immersed in insulating liquid. It does not apply to devices not subjected to the operating voltage of the system (for example, devices on tap changers). Such devices are not arresters.

13.2 Normative references

Clause 2 applies without modification.

13.3 Terms and definitions

Clause 3 applies, except as follows:

13.3.26

Replacement of Subclause 3.26:

3.26 housing of a liquid-immersed arrester

external electrically insulating enclosure of the arrester, which protects the internal parts from the environment

13.4 Identification and classification

Clause 4 applies without modification.

13.5 Standard ratings and service conditions

Clause 5 applies, except as follows:

13.5.4.1 Normal service conditions

Replacement of Subclause 5.4.1:

Surge arresters which conform to this standard shall be suitable for normal operation under the following normal service conditions.

- a) The ambient liquid temperature in the general vicinity of liquid-immersed arresters shall be between -40 °C and $+95\text{ °C}$.
- b) The daily average value of the maximum temperature of the ambient insulating liquid shall not exceed $+120\text{ °C}$.
- c) Frequency of the a.c. power supply not less than 48 Hz and not exceeding 62 Hz.
- d) Power-frequency voltage applied continuously between the terminals of the arrester not exceeding its continuous operating voltage.
- e) Mechanical conditions (no requirement at this time).

13.6 Requirements

Clause 6 applies except as follows:

13.6.13 Short-circuit performance

Replacement of Subclause 6.13:

An arrester shall not fail in a manner that causes violent shattering (see 13.8.10). The manufacturer shall declare a short-circuit current rating for each family of arresters. Only for applications with expected short-circuit currents below 1 kA the rated value “zero” may be claimed. In this case “0” shall be indicated on the name plate.

If a fail-open current rating is claimed, the tests shall be conducted at the lowest current level claimed.

If a fail-short current rating is claimed, the tests shall include the highest current level claimed.

13.7 General testing procedure

Clause 7 applies without modification.

13.8 Type tests (design tests)

13.8.1 General

Amendment:

Type tests shall be performed as defined in Clause 8, except for specific changes indicated below (list numbers refer to numbers in rows of Table 3):

- 1) Insulation withstand tests – see 13.8.2.
- 8) Tests of arrester disconnecter – does not apply.
- 9) Short-circuit tests – see 13.8.10.
- 10) Bending moment test – does not apply.
- 11) Environmental test – does not apply.
- 12) Seal leak rate test – does not apply.
- 16) Artificial pollution tests of Annex C – does not apply.

For liquid-immersed arresters, when testing in insulating liquid is required, the liquid shall be that which is used in the protected equipment.

13.8.2 Insulation withstand tests

Subclause 8.2 applies except as follows:

13.8.2.1 General

Replacement of Subclause 8.2.1:

The voltage withstand tests demonstrate the voltage withstand capability of the external insulation of the arrester housing. For other designs the test shall be agreed upon between the manufacturer and the user.

The tests shall be performed in the conditions and with the test voltages specified in 6.1 and repeated below. The outside surface of insulating parts shall be carefully cleaned and the internal parts removed or rendered inoperative to permit these tests.

The insulation withstand tests for liquid-immersed arresters shall be performed in insulating liquid at room temperature.

13.8.2.5 Wet test procedure

Replacement of Subclause 8.2.5:

Wet withstand tests under the procedure given in IEC 60060-1 do not apply to liquid-immersed arresters.

13.8.3 Residual voltage tests

Subclause 8.3 applies without modification.

13.8.4 Test to verify long term stability under continuous operating voltage

Subclause 8.4 applies, except as follows:

13.8.4.1 Test procedure

Replacement of Subclause 8.4.2.1:

This test shall be performed on three typical samples of MO resistor elements with a reference voltage fulfilling the requirements of 7.3. The power frequency voltage shall fulfil the requirements stated for the operating duty test (see 8.7.1).

All material (solid or liquid) in direct contact with the MO resistors in the arrester shall be present during the ageing test with the same design as used in the complete arrester.

During the test, the MO resistors shall be placed in a temperature-controlled oven in the same surrounding medium as used in the arrester. The volume of the oven chamber shall be at least twice the volume of the MO resistor and the density of the medium in the chamber shall not be less than the density of the medium in the arrester.

If the manufacturer can prove that the test carried out in the open air is equivalent to that carried out in the actual medium, the ageing procedure can be carried out in the open air.

The MO resistors shall be heated to $115\text{ °C} \pm 4\text{ K}$ and the MO resistor power losses P_{start} shall be measured at the corrected maximum continuous operating voltage of U_{ct} (see below) $3\text{ h} \pm 5\text{ min}$ after the voltage application. The samples shall be maintained at this voltage for $7\ 000\text{ h}$, during which the oven temperature shall be controlled to keep the surface temperature of the MO resistor at $115\text{ °C} \pm 4\text{ K}$. Test time may be reduced to not less than $2\ 000\text{ h}$ by agreement between manufacturer and user. This can be accomplished by monitoring the MO resistor power losses at least once every 100 h period, then extrapolating to $7\ 000\text{ h}$ using a straight line on a plot of power losses versus the square root of time from the lowest measured value through to the highest measured value.

The MO resistor power losses shall be measured at U_{ct} at intervals of not more than 100 h after the first measurement, and a final measurement, P_{end} , shall be made after $7\ 000\text{ }^{+100}_0\text{ h}$ of ageing. If a shorter test time is used, the final value, P_{end} , shall be determined by extrapolation to $7\ 000\text{ h}$ as described in the preceding paragraph. The lowest power losses attained during the test period shall be designated as P_{min} (see Figure 1).

Accidental intermediate de-energizing of the test samples, not exceeding a total duration of 24 h during the test period is permissible. The interruption will not be counted in the duration of the test. The final measurement should be performed after not less than 100 h of continuous energizing. Within the temperature range allowed, all measurements shall be made at the same temperature $\pm 1\text{ K}$.

The relevant voltage for this procedure is the corrected maximum continuous operating voltage (U_{ct}), which the MO resistors support in the arrester including voltage unbalance effects. This voltage shall be determined by voltage distribution measurements or computations.

NOTE Information on procedures for voltage distribution calculations is given in Annex F.

13.8.5 Test to verify the repetitive charge transfer rating, Q_{rs}

Subclause 8.5 applies without modification.

13.8.6 Heat dissipation behaviour of test sample

Subclause 8.6 applies without modification.

13.8.7 Operating duty tests

Subclause 8.7 applies except as follows:

13.8.7.2.3 Thermal recovery test

Replacement of Subclause 8.7.2.3:

The following procedure shall be applied for the thermal recovery part of the test:

The complete test samples shall be preheated to a temperature of at least 120 °C

The preheating shall take not more than twenty hours of time.

The temperature of the MO resistors shall be at least the start temperature immediately prior to the injection of energy or transfer of charge.

Each sample shall be subjected to injection of energy or transfer of charge, administered in the form of two 8/20 lightning current impulses within one minute, having a sufficient magnitude that the accumulated charge is at least equal to the claimed thermal charge transfer rating selected from the list given in Table 5.

Within 100 ms from the energy or charge application, a voltage equal to the rated voltage U_r shall be applied for 10 s and thereafter a voltage equal to the continuous operating voltage U_c (if necessary further adjusted as per 7.3) shall be applied for a minimum of 30 minutes to demonstrate thermal stability. Resistive component of current or power dissipation or temperature or any combination of them shall be monitored until the measured value is appreciably reduced (success), but for at least 30 minutes, or thermal runaway condition (failure) is evident.

13.8.8 Power frequency voltage-versus-time test

Subclause 8.8 applies without modification.

13.8.9 Tests of arrester disconnecter

Subclause 8.9 does not apply.

13.8.10 Short-circuit tests

Amendment:

All arresters shall be subjected to a short-circuit test according to 8.10 to show that the arrester will not fail in a manner that causes violent shattering of the housing. Modifications to 8.10 that are applicable to liquid-immersed arresters are as follows.

NOTE Revised short-circuit test procedures for liquid immersed arresters are under consideration.

13.8.10.1 General

Replacement of Subclause 8.10.1:

All arresters for which a short-circuit rating other than "zero" is declared shall be tested in accordance with this subclause. The test is conducted to show that an arrester failure is not likely to cause an explosive failure.

Each arrester design is tested with two groups of short-circuit currents according to Table 7:

high short-circuit current values consisting of the rated short-circuit current and two reduced short-circuit currents;

low short-circuit current.

NOTE 1 There are two principal designs with respect to short-circuit behaviour.

One design of surge arresters makes use of the internal overpressure, which is built up due to the internal arc coming from the short circuit of the arrester elements. The overpressure is created by heating an enclosed volume of gas or liquid, which expands, leading to bursting or flipping of a pressure-relief device (in this case, the tests are sometimes called "pressure-relief tests"). The arrester housing is not intended to break before the overpressure is relieved.

Another design, usually of a compact type with no enclosed volume of gas or liquid, does not have any pressure-relief device. The short-circuit performance of this design depends on the arc directly burning through or tearing the housing.

If the arrester is equipped with an arrangement other than a conventional pressure relief device, this arrangement should be included in the test.

For the rated and reduced short-circuit current, the methods of test sample preparation depend upon the arrester construction. For an arrester fitted with a pressure relief device, the active MO resistors are externally bypassed by a fuse wire. For an arrester without a pressure relief device, the active MO resistors may be pre-failed by overvoltage or may be bypassed with an internal fuse wire installed in a drilled hole through the MO resistors.

For the low-current short-circuit test, active MO resistors are pre-failed by overvoltage.

The frequency of the short-circuit current test supply should be not less than 48 Hz and not greater than 62 Hz.

Upon agreement between the manufacturer and the user reclosing cycles tests may be performed using a mutually agreed upon test procedure and test criteria.

Liquid-immersed arresters may be designed as either "fail-open" or "fail-short". It is recognized that a fail-open design arrester will not always fail in an open-circuit mode for fault currents below its fail-open rating, and that a fail-short design arrester will not always fail in a short-circuit mode for available fault currents above its fail-short rating.

NOTE 2 "Fail-open" does not imply that the arrester will interrupt the circuit. All arrester failures initiate short-circuit current which are usually interrupted by an overcurrent protective device. After other devices clear the fault, the fail-open arrester allows re-energisation of the protected equipment with, of course, no overvoltage protection.

The tests shall be run on each of three of the lowest and highest voltage ratings of a complete single arrester unit for each type and design for which a fail-open or fail-short current rating is claimed. These tests shall be considered to substantiate conformance to this standard for intermediate voltage ratings of the same type and design.

For fail-open design arresters, all specimens are tested at the lowest claimed fail-open current level. No samples are tested at the "low short-circuit current" level which may be below the fail-open current rating.

For fail-short design arresters, one sample shall be tested at each of the three current levels according to 8.10.2. The nominal short-circuit level may be different from that listed in Table 7 and shall be selected by the manufacturer. The two reduced short-circuit current levels shall be selected from Table 10. One additional sample shall be tested according to 8.10.3.

13.8.10.3 Mounting of the test samples

Replacement of Subclause 8.10.3:

The test samples shall be mounted in the position intended to be used when mounted in service, including orientation and distance from grounded parts. The arrester shall be immersed in insulating liquid in a container sufficiently large that it does not become involved in arcing activity.

13.8.10.4 High current short-circuit tests

Replacement of Subclause 8.10.4:

One sample shall be tested at a rated short-circuit current selected from Table 7. Second and third samples shall be tested, one at each of the two reduced short-circuit currents corresponding to the selected rated short-circuit current. All three samples shall be prepared according to 8.7.2 and mounted according to 8.7.3.

Tests shall be made in a single-phase test circuit, with an open-circuit test voltage of 107 % to 77 % of the rated voltage of the test sample arrester, as outlined in 8.7.2.1. However, it is expected that tests on high-voltage arresters will have to be made at a testing station which might not have the sufficient short-circuit power capability to carry out these tests at 77 % or more of the test sample rated voltage. Accordingly, an alternative procedure for making the high-current short-circuit tests at a reduced voltage is given in 8.7.2.2. The measured total duration of test current flowing through the circuit shall be equal to, or greater than, 0,2 s.

For fail-open design arresters, the impedance of the test circuit shall be adjusted to produce not more than the fail-open current rating of the arrester through the specimen. The fail-open rating which can be claimed is the highest measured r.m.s. symmetrical current which flows in any specimen during the test.

For fail-short design arresters, the impedance of the circuit shall be adjusted to produce not less than the fail-short current rating of the arrester through the specimen. The fail-short rating which can be claimed is the lowest measured r.m.s. symmetrical current which flows through any specimen during the nominal current test.

13.8.10.5 Evaluation of test results

Replacement of Subclause 8.10.5:

The conformance of the test specimens with this standard shall be judged by the following:

from the oscillographic recordings showing test current amplitude and duration;

from the results of the following voltage withstand test made at any time after the short-circuit event. The specimen shall be energized at U_c in a circuit with limited, but known, available current for a period of 1 min during which time

- 1) substantially no current flows in the case of a fail-open design arrester, or
- 2) substantially full available current flows in the case of a fail-short design arrester;

from the physical appearance of the specimens after the test.

All tested specimens shall meet these requirements.

13.8.11 Test of the bending moment

Subclause 8.11 does not apply.

13.8.12 Environmental tests

Subclause 8.12 does not apply.

13.8.13 Seal leak rate test

Subclause 8.13 does not apply.

13.8.14 Radio interference voltage (RIV) test

Subclause 8.14 applies without modification.

13.8.15 Test to verify the dielectric withstand of internal components

Subclause 8.15 applies without modification.

13.8.16 Test of internal grading components

Subclause 8.16 applies without modification.

13.9 Routine tests and acceptance tests

Clause 9 applies without modification.

Annex A (normative)

Abnormal service conditions

The following are typical abnormal service conditions which may require special consideration in the manufacture or application of surge arresters and should be called to the attention of the manufacturer.

- 1) Temperature in excess of +40 °C or below –40 °C.
- 2) Application at altitudes higher than 1 000 m.
- 3) Fumes or vapours which may cause deterioration of insulating surface or mounting hardware.
- 4) Excessive contamination by smoke, dirt, salt spray or other conducting materials.
- 5) Excessive exposure to moisture, humidity, dropping water or steam.
- 6) Live washing of arrester.
- 7) Explosive mixtures of dust, gases or fumes.
- 8) Abnormal mechanical conditions (earthquakes, vibrations, high wind velocities, high ice loads, high cantilever stresses).
- 9) Unusual transportation or storage.
- 10) Nominal frequencies below 48 Hz and above 62 Hz.
- 11) Heat sources near the arrester (see 5.4b).
- 12) Wind speed > 34 m/s.
- 13) Non-vertical erection and suspended erection.
- 14) Earthquake (see G.2)
- 15) Torsional loading of the arrester
- 16) Tensile loading of the arrester
- 17) Use of the arrester as a mechanical support.

Annex B (normative)

Test to verify thermal equivalency between complete arrester and arrester section

For tests involving thermal recovery in which prorated arrester sections are used, it is required that the sections are thermally equivalent to the complete arrester. The following procedure shall be followed to demonstrate this equivalency. It involves tests first on the complete arrester or, in case of a multi-unit arrester, the unit containing the most MO resistors per unit length, followed by a test on the prorated section.

a) Test on the complete arrester or unit:

The complete arrester or the unit containing the most MO resistors per unit length of a multi-unit arrester shall be placed in a still air ambient temperature of $20\text{ °C} \pm 15\text{ K}$. The ambient temperature shall remain within $\pm 3\text{ K}$ during the test. Thermocouples and/or some sensors, for example, utilizing optical fibre technique to measure temperature shall be attached to the resistors. A sufficient number of points shall be checked to calculate a mean temperature or the manufacturer may choose to measure the temperature at only one point located between 1/2 to 1/3 of the arrester length from the top. The latter will give a conservative result, thus justifying the simplified method.

The MO resistors shall be heated within a maximum of 1 hour to a temperature of at least 140 °C by the application of power-frequency voltage with an amplitude above reference voltage. This temperature shall be determined by the mean value if the temperature is measured on several MO resistors or the single value if only the 1/2 to 1/3 point is checked.

In case of multi-column internal design, measures may have to be taken to achieve equal temperatures of all MO resistor columns, e.g. by adding one or more linear resistors to each of the columns in each unit. These resistors shall have a mass of not more than 5 % of the mass of MO resistors in the related columns, and they shall be positioned directly on the top or bottom of the column. If this measure cannot be taken, an alternative is to use small bushings in the metal flanges and place the linear resistors outside the housing.

The temperature shall be measured on all individual MO resistor columns and the average temperature be used as column temperature. The difference between the highest and the lowest temperature among the individual columns measured at the same height shall not be greater than 20 K at an average temperature of 140 °C .

When this predetermined temperature is reached, the voltage source shall be disconnected and the cooling time curve shall be determined over a period of not less than 2 h. The temperature shall be measured at least every minute. In the case of several measuring points a mean temperature curve shall be constructed.

Test on the thermally prorated section:

The thermally prorated section shall be tested in still air in the same manner as the complete arrester or arrester unit was tested.

The ambient temperature shall be within $\pm 10\text{ K}$ of the ambient temperature during the test on the complete arrester or arrester unit and remain within $\pm 3\text{ K}$ during the test. The section shall be heated by the application of power frequency voltage to a temperature rise above ambient that is within $\pm 10\text{ K}$ of the temperature rise that occurred for the complete arrester or unit. The voltage amplitude is chosen to give a heating time approximately the same as for the complete arrester or unit.

If the prorated section contains only one column with several MO resistors in series the temperature of all MO resistors shall be measured and a mean value calculated for comparison with the complete arrester.

If, in case of designs with two or more MO resistor columns in parallel, it is not possible to achieve a difference between the highest and the lowest temperature among the individual

columns not greater than 20 K at the maximum heating temperature by alternating current heating, one of the two following methods shall be applied:

1) External linear resistors shall be used to balance the current distribution among the columns. Each column shall be connected to the alternating voltage source by a small individual bushing. Application of internal linear series resistors to achieve equal temperatures is not allowed

or

2) Heating shall be performed by application of long-duration current impulses at time intervals such that the same overall heating time is achieved as previously for the complete arrester or arrester unit.

A mean temperature shall be determined by measuring the temperature of several MO resistors in each column. Alternatively, the temperature may be measured on one MO resistor located between 1/2 to 1/3 of the section from the top. When the section has reached the predetermined temperature, the voltage source shall be disconnected and the cooling time curve shall be determined over a period of not less than 2 h.

Cooling curves displaying the relative overtemperature of the complete arrester or unit and of the section shall be plotted, the relative overtemperature, T_{rel} , being given by

$$T_{rel} = (T - T_A)/(T_0 - T_A) \quad (\text{B.1})$$

where

- T is the measured temperature during cooling;
- T_A is the average ambient temperature during the test;
- T_0 is the maximum heating temperature.

To prove thermal equivalency, the cooling curve of the section shall for all instants have a relative overtemperature value equal to or higher than that of the complete arrester or unit.

If, at any time, the measured cooling curve of the section falls below the measured cooling curve of the complete arrester or unit, compensation may be made by adding a factor, k , to the relative overtemperature, T_{rel} , such that the cooling curve of the section is at or above the cooling curve of the complete arrester or unit over the entire cooling period. The corresponding temperature which shall be added to the start temperature for the thermal recovery tests is calculated as: $k*(T_0 - T_A)$ where $(T_0 - T_A)$ is the maximum temperature difference for either the section or the complete arrester or arrester unit.

Annex C (normative)

Artificial pollution test with respect to the thermal stress on porcelain housed multi-unit metal-oxide surge arresters

C.1 Glossary

C.1.1 Measured quantities

q_z (in C/hm)	Mean external charge flowing on the surface of insulators and surge-arrester housings during pollution events in service, relevant to a pollution event lasting a time t_z . This parameter is used for the classification of the pollution severity of a site.
t_z (in h)	Duration of a pollution event in service.
Q_e (in C)	Charge flowing on the surface of the units of the surge arrester during the pollution test.
Q_i (in C)	Charge flowing in the internal parts of the units of the surge arrester during the pollution test.
ΔT_k (in K)	Temperature rise relevant to unit k.
β (in K/C)	Ratio between the temperature rise of the internal parts of the arrester and the relevant charge flowing internally as determined in the preliminary heating test.
τ (in h)	Equivalent thermal time constant of the arrester as determined in the preliminary heating test.

C.1.2 Calculated quantities

D_m (in m)	Average diameter of the surge-arrester housing: it is calculated according to the method reported in IEC/TS 60815-2.
Q_{tot} (in C)	Total charge relevant to the surge arrester: it is the sum of Q_i and Q_e and is measured at the earth terminal of the surge arrester.
$\Delta T_{Z\ max}$ (in K)	Maximum theoretical temperature rise in service calculated as a function of β , q_z , t_z , D_m and τ .
WU	Weighted unbalance of the arrester calculated as a function of the electrical and geometrical characteristic of each unit of the surge arrester. This parameter is used to select the most critical design to be submitted to the pollution test.
K_{ie}	Ratio between the maximum external charge and the maximum internal charge flowing in the surge-arrester units during the pollution test.
ΔT_z (in K)	Expected temperature rise in service calculated as a function of β , q_z , t_z , D_m , K_{ie} and τ .
T_{OD} (in °C)	Starting temperature to be used for the operating duty test.

C.2 General

Pollution on external insulation of a metal-oxide surge arrester should be considered with regard to three possible effects:

- a) risk of external flashover;
- b) partial discharges inside the surge arrester due to radial fields between the external surface and the internal active elements;
- c) temperature rise of the internal active elements due to a non-linear and transient voltage grading caused by the pollution layer on the surface of the arrester housing.

This test procedure considers only the third possible effect. A preliminary calculation of the maximum theoretical temperature rise shall be performed according to C.5. If the result of the calculation is less than 40 K, no test is required. If the result of the calculation is 40 K or higher, a test according to this Annex shall be performed unless, by agreement between user and manufacturer (for example, based on service experience in specified environments), the test can be omitted.

Laboratory tests and service experience have shown that the heating of the internal active parts of the surge arrester under pollution conditions is related to the charge absorbed: this parameter is therefore considered essential in the evaluation of the pollution performance of surge arresters.

A classification of the pollution severity of representative sites has been set up considering the mean external charge flowing on the surface of different insulators and surge arresters.

The procedures described in this annex refer only to surge arresters with a porcelain housing; the procedures for polymeric type surge arresters may require further investigation and are presently under consideration.

This annex describes the procedure for the determination of the preheating to be applied to the test sample before the operating duty test, in order to take into account the heating effect of the pollution; this procedure is synthesized in the flow-chart of Figure C.1. In particular:

- the pollution severity of different representative sites is expressed in terms of q_z . Relevant data are given in Table C.1;
- the thermal characteristics of the surge arrester are determined according to a procedure derived from that of 8.6. This procedure allows the determination of the equivalent thermal time constant τ and the calculation of the parameter β by means of the criteria described in C.4;
- the knowledge of the thermal characteristics of the surge arrester and of the expected pollution severity of the site in which the surge arrester is going to be installed allows a preliminary calculation of the maximum temperature rise in the most conservative conditions in which all the charge relevant to the pollution event would flow internally into the surge arrester;
- if the calculation of the maximum temperature rise $\Delta T_{z \max}$ results in values less than 40 K, the pollution tests are not required and the starting temperature of the operating duty test shall be 60 °C. If the calculation of the maximum temperature rise $\Delta T_{z \max}$ results in values of 40 K or higher, a test according to the procedure described in this annex shall be carried out unless, by agreement between user and manufacturer (for example, based on service experience in specified environments), the pollution test can be omitted. Moreover, at the decision of the manufacturer, even if the calculation of $\Delta T_{z \max}$ results in values higher than 40 K, the pollution test may be avoided using as a starting temperature for the operating duty test the value $(20 + \Delta T_{z \max})$ °C;
- laboratory pollution tests, when deemed necessary, are carried out on a surge arrester representative of a certain type and design. During the pollution test, the external and

internal charges Q_e and Q_i shall be measured for each surge-arrester unit. Alternatively, the total charge Q_{tot} and the temperature rise ΔT of the internal parts may be measured. A statistical analysis of the test results is necessary to take into account the stochastic behaviour of the surge arrester heating under pollution conditions. The elaboration of the test results, described in detail in the following clauses, gives the factor K_{ie} which expresses the tendency of the charge to flow internally and therefore to heat the active parts. This factor is a characteristic value for a given surge-arrester type and design;

- the expected temperature rise ΔT_z in service is calculated as a function of q_z , K_{ie} , D_m , t_z , β and τ ;
- the starting temperature T_{OD} of the operating duty test is calculated on the basis of the following criteria:
 - if ΔT_z is greater than 40 K, $T_{OD} = 20\text{ °C} + \Delta T_z$;
 - if ΔT_z is lower than or equal to 40 K, $T_{OD} = 60\text{ °C}$;
- the operating duty test is performed according to the procedure described in 8.7 with a starting temperature equal to T_{OD} .

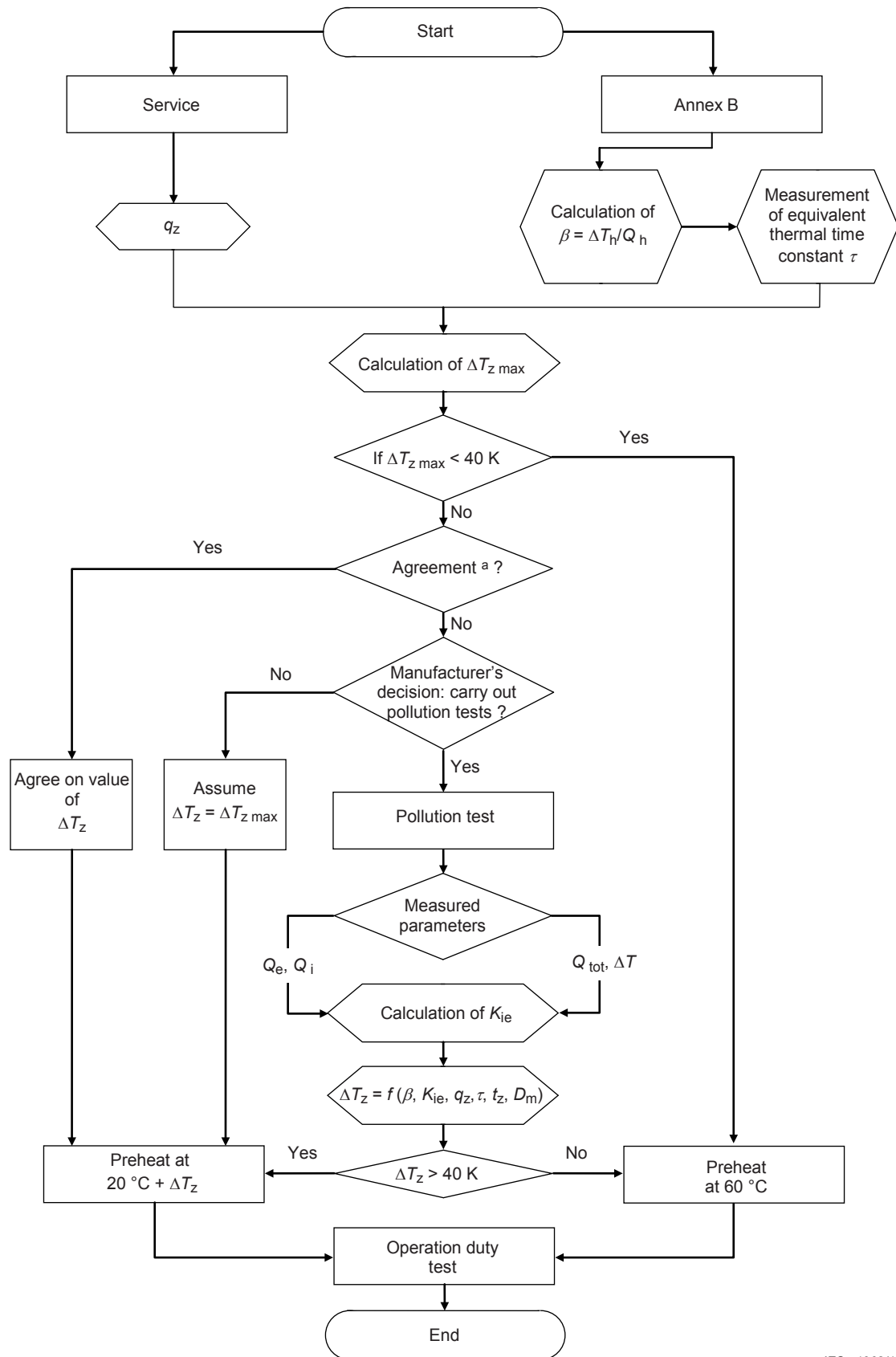

IEC 1968/14

^a Agreement between user and manufacturer (for example, based on service experience in specified environment).

Figure C.1 – Flow-chart showing the procedure for determining the preheating of a test sample

C.3 Classification of site severity

The classification of the pollution severity of a site is made on the basis of the expected mean external charge q_z , based on measurements carried out in sites representative of different pollution severities.

Considering that the charge flowing on the surface of an insulator is proportional to its diameter, the value of q_z is normalized to an equivalent diameter of 1 m.

The duration of pollution phenomena (t_z) are assumed as follows:

- pollution event of medium duration with high intensity: 2 h;
- pollution event of long duration: 6 h.

The value of q_z to be considered in the subsequent calculations is that one corresponding to the most severe situation (2 h or 6 h), according to equation (C.2), for the pollution level relevant to the site of installation of the surge arrester.

The values of q_z for the different pollution zones are given in Table C.1.

Table C.1 – Mean external charge for different pollution severities

Pollution level (zone ^a)	Minimum reference unified specific creepage distance (RUSCD) mm/kV	q_z : mean external charge C/h·m	
		$t_z = 2 \text{ h}$	$t_z = 6 \text{ h}$
b – Light	28	0,5	0,24
c – Medium	35	3,3	2,4
d – Heavy	44	24,0	14,0
e – Very heavy	55	55,0	36,0

^a Pollution levels (zones) correspond to the definition of pollution levels given in 8.3 of IEC TS 60815-2:2008. No value is available for the new pollution class “a” according to IEC TS 60815-1 and the related RUSCD value according to IEC TS 60815-2, respectively.

NOTE The q_z values were obtained using a threshold value of 2 mA (see F.6.3.1).

C.4 Preliminary heating test: measurement of the thermal time constant τ and calculation of β

A procedure similar to that specified in 8.6, relevant to the complete arrester, shall be used, but with the following exceptions:

- the heating time (t_h) shall be shorter than 10 min;
- the charge Q_h applied to the surge arrester during the heating shall be measured;
- τ is the time derived from the cooling curve of the arrester between the temperatures of 60 °C and $22 + 0,63 T_a$, where T_a is the ambient temperature in degrees Celsius.

The parameter β shall be calculated according to the following equation:

$$\beta = \frac{\Delta T_h}{Q_h} \quad (\text{C.1})$$

where

ΔT_h is the temperature rise during the heating test;

Q_h is the charge applied during the heating test.

After the heating test, it shall be verified that the heating time (t_h) is shorter than $0,1 \times \tau$, otherwise the heating test shall be repeated with a shorter t_h .

C.5 Verification of the need to perform the pollution tests

In order to check the effective need to carry out the pollution test, a preliminary calculation of the maximum theoretical temperature rise in service ($\Delta T_{z \max}$) shall be carried out. This calculation assumes that all the charge expected in service (q_z) flows internally. In this hypothesis, $\Delta T_{z \max}$ can be derived as follows:

$$\Delta T_{z \max} = \beta q_z D_m \tau \left(1 - e^{-\left(\frac{t_z}{\tau}\right)} \right) \left(\frac{U_r - U_{r \min}}{U_r} \right) \quad (\text{C.2})$$

where

U_r is the rated voltage of the surge arrester;

$U_{r \min}$ is the minimum rated voltage among the surge arrester units.

If the calculation of the maximum temperature rise $\Delta T_{z \max}$ results in values less than 40 K, the pollution tests are not required and the starting temperature of the operating duty test shall be 60 °C. If the calculation of the maximum temperature rise $\Delta T_{z \max}$ results in values of 40 K or higher, a test according to the procedure described in this annex shall be carried out unless, by agreement between user and manufacturer (for example, based on service experience in specified environments), the pollution test can be omitted. Moreover, at the decision of the manufacturer, even if the calculation of $\Delta T_{z \max}$ results in values higher than 40 K, the pollution test may be avoided by using as starting temperature for the operating duty test the value $(20 + \Delta T_{z \max})$ °C.

C.6 General requirements for the pollution test

C.6.1 Test sample

The test sample shall be representative of the most critical design relevant to a certain arrester type.

The characteristics of the test sample shall be selected according to the criteria given in Table C.2.

Table C.2 – Characteristic of the sample used for the pollution test

Parameter	Selection criteria (characteristic of the sample to be tested with respect to the relevant design type)
U_C/U_R	Maximum
Weighted unbalance (WU) ^a	Maximum
Specific creepage distance [mm/kV]	Minimum
Block cross-sectional area	Minimum
Equivalent porcelain diameter	Maximum
<p>^a The weighted unbalance (WU) shall be derived as follows:</p> $WU = \max \left(\frac{U_{rk}^2 CD}{CD_k U_r^2} \right) \quad (C.3)$ <p>where</p> <p>U_r is the rated voltage of the surge arrester;</p> <p>U_{rk} is the rated voltage of the unit k;</p> <p>CD is the creepage distance of the surge arrester;</p> <p>CD_k is the creepage distance of the unit k;</p> <p>$k = 1, 2 \dots n$;</p> <p>n is the number of units of the surge arrester.</p>	

C.6.2 Testing plant

The testing plant shall fulfil the requirements of 6.2 of IEC 60507:2013.

C.6.3 Measuring devices and measuring procedures

C.6.3.1 Measurement of the charge

A suitable device for the measurement of the charge shall be used.

For the measurement of the internal charge, only the resistive component of the current shall be considered: the effect of the capacitive current on the charge measurement shall be eliminated. Examples of methods for eliminating the effect of the capacitive current are the waveform subtraction method or the integration upon exceeding a threshold limit (for example, 2 mA (see Table C.1)).

The minimum requirements for the measuring device are given in Table C.3.

Table C.3 – Requirements for the device used for the measurement of the charge

Characteristic	Requirement
Minimum current integration range	0 mA to 500 mA
Minimum current resolution	0,2 mA
Minimum analogue bandwidth	0 Hz to 2 000 Hz
Minimum sampling frequency	1 000 Hz
Maximum updating period of the charge	1 min
Maximum residual capacitive charge in the updating period	±10 % of the total charge in the updating period
Maximum overall measurement uncertainty	±10 %

In the case of two-unit surge arresters, the internal and external charges shall be measured both on the line and earth terminals.

In the case of surge arresters composed of more than two units, the following measuring procedure shall be adopted:

- the internal and external charges shall be measured on the line and earth terminals of the surge arrester;
- only the external charge shall be measured for intermediate units;
- the internal charge is evaluated by means of the following equation:

$$Q_i = \frac{(Q_{iT} + Q_{eT}) + (Q_{iB} + Q_{eB})}{2} - Q_e \quad (\text{C.4})$$

where

Q_i is the internal charge of the intermediate unit;

Q_{iT} is the internal charge of the top unit;

Q_{iB} is the internal charge of the bottom unit;

Q_e is the external charge of the intermediate unit;

Q_{eT} is the external charge of the top unit;

Q_{eB} is the external charge of the bottom unit.

C.6.3.2 Measurement of the temperature

The temperature of the internal parts of the arrester may be measured instead of the internal charge.

In this case the measurement of the temperature shall be performed by means of sensors positioned in at least three evenly distributed positions along each unit. The distance between the sensors shall be $h/(n+1)$ where h is the height of the unit and n the number of sensors used.

The minimum requirements for the devices are given in Table C.4.

Table C.4 – Requirements for the device used for the measurement of the temperature

Characteristic	Requirement
Temperature measuring range	20 °C to 200 °C
Absolute measuring uncertainty	±1 K
Resolution	≤0,4 K
Maximum thermal time constant	1 min
Minimum sampling rate	1 min ⁻¹
NOTE Typical temperature rises in the test are below 100 K.	

In the case of internal temperature measurement, the charge Q_{tot} shall be measured only at the earth terminal of the surge arrester.

C.6.4 Test preparation

C.6.4.1 Cleaning of the test sample

The surge-arrester housing shall be carefully cleaned so that all traces of dirt and grease are removed.

After cleaning the insulating parts of the surge arrester shall not be touched by hand.

Water, preferably heated to 50 °C, with the addition of trisodium phosphate or equivalent detergent, shall be used, after which the insulator shall be thoroughly rinsed with tap water.

The surface of the insulator is deemed sufficiently clean and free from any grease if large continuous wet areas are observed.

C.6.4.2 Installation of the sample

The arrester shall be tested completely assembled as intended to be used in service. The devices used for the measurement of the charge and of the temperature shall not have any significant influence on the behaviour of the surge arrester under test.

C.7 Test procedures

One of the two test procedures described in C.7.1 and C.7.2 may be used.

C.7.1 Slurry method

C.7.1.1 General

C.7.1.1.1 Contaminant preparation

The contaminant shall be stored in a container so that it can be thoroughly agitated just prior to application. The contaminant shall consist of a slurry of

- water;
- bentonite, 5 g per litre of water;
- an undiluted non-ionic detergent consisting of nonyl-phenol-polyethylene-glycol-ether, or other comparable long-chain non-ionic ether; 1 g per litre of water;
- sodium chloride.

The volume resistivity of the slurry shall be adjusted by the addition of sodium chloride to a range between 400 Ω .cm and 500 Ω .cm.

Volume resistivity shall be measured at a temperature of 20 °C. If, during the measurement of the volume resistivity, the temperature of the slurry is different from 20 °C, a calculation for temperature correction shall be made.

C.7.1.1.2 Ambient conditions

At the start of the test, the surge arrester shall be in thermal equilibrium with the air in the test chamber. The ambient temperature shall not be less than 5 °C nor greater than 40 °C.

C.7.1.2 Preconditioning of the surge-arrester surface

Before starting the preconditioning, the reference voltage of the surge arrester shall be determined, according to the procedure specified in 7.2.

The following steps shall be applied.

- a) With the arrester de-energized, the pollutant shall be applied to the complete arrester, including the underside of the sheds. The pollution layer shall appear as a continuous film. Maximum time for application of the pollutant is 10 min.
- b) Three minutes after the slurry application is completed the arrester shall be energized at a voltage U_c (see note 2 of C.7.1.3) for 10 min.
- c) The arrester shall be cleaned by washing with water and thereafter left to drip dry.
- d) Steps a), b) and c) shall be repeated three times.

At the end of the preconditioning process, the surge arrester shall be left to cool at ambient temperature.

In order to verify that no damage has occurred to the surge arrester during the preconditioning process, the reference voltage of the surge arrester shall be measured and compared with the measurement performed before the preconditioning. Acceptable limits of variation of the reference voltage shall be specified by the manufacturer.

The test shall start as soon as possible after completion of the preconditioning process.

C.7.1.3 Test procedure

The following steps shall be applied.

- a) With the arrester de-energized, the pollutant shall be applied to the complete arrester, including the underside of the sheds. The pollution layer shall appear as a continuous film. Maximum time for application of the pollutant is 10 min.
- b) Three minutes after the slurry application is completed the arrester shall be energized at a voltage U_c (see note 2) for 10 min; the charge measurement shall start at the moment of voltage application.
- c) The arrester shall be cleaned by washing with water and thereafter left to drip dry. Before starting the next test the internal parts of the arrester shall be left to cool to maximum ± 2 K from the average ambient temperature. If the temperature of the internal parts is not measured, a minimum time of 2τ shall be interposed between two subsequent tests in order to ensure that the surge arrester has cooled close to ambient temperature. Any means to cool the arresters to near ambient temperature, which are accepted by the manufacturer, are permitted. Several arresters may be tested in parallel in order to reduce the waiting time.
- d) Steps a), b) and c) shall be repeated five times.
- e) The expected temperature rise ΔT_z shall be calculated according to the procedure specified in Clause C.8.
- f) If the value of ΔT_z is lower than 40 K, no further pollution test is required and the starting temperature T_{OD} of the operating duty test shall be 60 °C. If the value of ΔT_z is higher than, or equal to, 40 K, steps a), b) and c) shall be repeated five more times and the expected temperature rise ΔT_z shall be calculated according to the procedure specified in Clause C.8.

NOTE Washing after each cycle is used to remove any influence from previous test cycles and thus improve the statistical independence between test cycles.

In cases in which the continuous operating voltage out of other reasons has been selected much higher than the phase-to-earth operating voltage of the system, the test may be carried out at the phase-to-earth voltage by agreement between manufacturer and user.

C.7.2 Salt fog method

C.7.2.1 General

C.7.2.1.1 Contaminant preparation

The salt solution shall be prepared in accordance with Clause 7 of IEC 60507:2013: the salt solution shall be made of sodium chloride (NaCl) of commercial purity and tap water.

The salinity used shall be two steps below the specified withstand salinity of the surge arrester. Tolerances on the value of the salinity shall be in accordance with Clause 7 of IEC 60507:2013. The measurement of the salinity shall be made by measuring the conductivity with a correction of temperature in line with the indications of IEC 60507.

C.7.2.1.2 Spraying system

The system for the production of the salt fog shall be in accordance with the specifications of Clause 8 of IEC 60507:2013.

C.7.2.1.3 Preconditioning of the arrester surface

Before starting the preconditioning, the reference voltage of the surge arrester shall be determined, according to the procedure specified in 7.2.

The preconditioning process shall be carried out on one unit of the surge arrester at a time. If the preconditioning is carried out on the units assembled in the surge arrester, the other units are therefore short-circuited with an external wire, and are not energized.

The unit shall be energized at voltage U_c and submitted to the salt fog for 20 min or until flashover.

If flashover does not occur, the voltage is raised to the rated voltage of the surge arrester unit for 5 s or until flashover, and then lowered again to the U_c value for 5 min. This procedure is repeated until eight flashovers are obtained.

In order to obtain the eight flashovers without an excessively high number of voltage increase cycles, the preconditioning shall be carried out at a value of salinity preferably higher than the expected maximum withstand level of the unit.

Alternatively, by agreement between the manufacturer and the user, the preconditioning may be carried out on the arrester housing without the internal elements.

After the preconditioning of each unit, the fog shall be cleared and the surge arrester shall be washed down with tap water.

At the end of the preconditioning process, the surge arrester shall be allowed to cool to ambient temperature.

In order to verify that no damage has occurred to the surge arrester during the preconditioning process, the reference voltage of the surge arrester shall be measured and compared with the measurement carried out before the preconditioning. Acceptable limits of variation of the reference voltage shall be specified by the manufacturer.

The salt fog test shall start as soon as possible after completion of the preconditioning process.

At the start of the test, the surge arrester shall be in thermal equilibrium with the air in the test chamber. The ambient temperature shall not be less than 5 °C nor greater than 40 °C and its difference from the temperature of the water solution shall not exceed 15 K.

C.7.2.2 Test procedure

The following steps shall be applied.

- a) The surge arrester shall be uniformly rinsed with tap water. The test voltage U_c shall be applied while the surge arrester is still completely wet. In cases in which the continuous operating voltage out of other reasons has been selected much higher than the phase-to-earth operating voltage of the system, the test may be carried out at this phase-to-earth voltage by agreement between manufacturer and user.

The surge arrester shall be energized at the specified test voltage and the salt-solution pump and air compressor shall be switched on. The test is deemed to have started as soon as the compressed air has reached the normal operating pressure at the nozzles. This starting time is intended also for the charge measurement system.

The fog production shall be stopped after 15 min and the surge arrester shall be kept energized for another 15 min.

The salt fog shall be evacuated and the surge arrester shall be allowed to cool to ambient temperature before starting the subsequent cycle. In order to ensure that the surge arrester has cooled close to ambient temperature a minimum time of 2τ shall be interposed between two subsequent tests. Any means to cool the arresters to near ambient temperature, which are accepted by the manufacturer, are allowed. Several arresters may be tested in parallel in order to reduce the waiting time.

Steps a), b), c) and d) shall be repeated five times.

The expected temperature rise ΔT_z shall be calculated according to the procedure specified in Clause F.8.

If the value of ΔT_z is lower than 40 K, no further pollution test is required and the starting temperature T_{OD} of the operating duty test shall be 60 °C. If the value of ΔT_z is higher than, or equal to, 40 K, steps a), b), c) and d) shall be repeated five more times and the expected temperature rise ΔT_z shall be calculated according to the procedure specified in Clause C.8.

NOTE Washing after each cycle is used to remove any influence from previous test cycles and thus improve the statistical independence between test cycles.

C.8 Evaluation of test results

C.8.1 Calculation of K_{ie}

For each repetition of the test cycle the value of K_n is calculated as follows:

$$K_n = \frac{\sum \left(\frac{Q_{ik} U_{rk}}{U_r} \right)}{Q_{e \max}} \quad (C.5)$$

where

$Q_{e \max}$ is the maximum of external charge levels;

Q_{ik} is the internal charge relevant to unit k;

U_{rk} is the rated voltage of unit k;

U_r is the rated voltage of the surge arrester;

$k = 1, 2 \dots n$;

n is the number of units of the surge arrester.

In the case in which the temperature of the internal parts has been measured instead of the internal charge, equation (C.5) is replaced by equation (C.6):

$$K_n = \frac{\sum \left(\frac{\Delta T_k U_{rk}}{\beta U_r} \right)}{Q_{e \max}} \quad (\text{C.6})$$

where ΔT_k is the temperature rise relevant to unit k calculated as the arithmetical mean value between the maximum temperature measured in the different points of the unit.

NOTE If the internal temperature rise ΔT_k is directly measured during the test, $Q_{e \max}$ can be calculated according to the following equation:

$$Q_{e \max} = \max \left(Q_{\text{tot}} - \frac{\Delta T_k}{\beta} \right) \quad (\text{C.7})$$

The average value K_{ieM} is calculated as the arithmetical mean of the values of K_n , σ is calculated as the standard deviation of the values of K_n , and the statistical ratio K_{ie} is calculated according to the following formula:

$$K_{ie} = K_{ieM} + c \sigma \quad (\text{C.8})$$

where

$c = 2$ in the case where the calculation is carried out on the basis of the measurements relevant to 10 test cycles;

$c = 2,9$ in the case where the calculation is carried out on the basis of the measurements relevant to five test cycles.

C.8.2 Calculation of the expected temperature rise ΔT_z in service

The expected temperature rise ΔT_z is calculated according to the following equation:

$$\Delta T_z = \beta K_{ie} q_z D_m \tau \left(1 - e^{-\left(\frac{t_z}{\tau} \right)} \right) \quad (\text{C.9})$$

C.8.3 Preparation for the operating duty test

The starting temperature T_{OD} of the operating duty test is calculated on the basis of the following criteria:

- 1) if ΔT_z is greater than 40 K, $T_{OD} = 20 \text{ °C} + \Delta T_z$;
- 2) if ΔT_z is lower than or equal to 40 K, $T_{OD} = 60 \text{ °C}$.

The operating duty test is performed according to the procedure described in 8.7 with a starting temperature equal to T_{OD} .

C.9 Example

The following example refers to the application of the test procedure on a surge arrester having the following ratings:

U_r 198 kV

$U_{r \text{ min}}$	90 kV
U_c	156 kV
test voltage	142 kV (see note)
number of units	2
U_r (bottom element)	90 kV
U_r (top element)	108 kV
D_m	198 mm

NOTE The value of the test voltage was chosen in line with note 2 of C.7.2.2.

C.9.1 Preliminary heating test

The results of the preliminary heating tests are the following:

τ	1,5 h
β	19 K/C (i.e. a charge of 5,3 C was necessary to heat the surge arrester from 20 °C to 120 °C).

C.9.2 Verification of the need to perform the pollution test

The calculation of $\Delta T_{z \text{ max}}$, by means of equation (C.2) gives the results reported in Table C.5.

Table C.5 – Calculated values of $\Delta T_{z \text{ max}}$ for the selected example

Pollution zone	Duration of pollution event	$\Delta T_{z \text{ max}}$	Need to perform the pollution tests
	h	K	
b	2	1,1	No
	6	0,7	
c	2	7,5	No
	6	7,3	
d	2	54,4	Yes
	6	42,3	
e	2	124,7	Yes
	6	108,8	

NOTE Pollution zones correspond to the definition of pollution levels given in 8.3 of IEC TS 60815-1:2008. No value is available for the new pollution class “a” according to IEC TS 60815-1 and the related RUSCD value according to IEC TS 60815-2 respectively.

The application of the surge arrester in pollution zones b and c does therefore not require the pollution tests, and the starting temperature of the operating duty test shall be taken as 60 °C.

C.9.3 Salt fog tests

The results of the salt fog tests, at a salinity of 14 kg/m³, are given in Table C.6.

Table C.6 – Results of the salt fog test for the selected example

Test No.	$Q_{\text{ebot}}^{\text{a}}$	$Q_{\text{etop}}^{\text{c}}$	$Q_{\text{itop}}^{\text{d}}$	$Q_{\text{ibot}}^{\text{b}}$	K_n
	C	C	C	C	
1	6,7	4,1	2,3	0	0,18
2	5,9	4,2	1,3	0	0,12
3	6,4	4,3	1,8	0	0,15
4	6,7	4,5	2,2	0	0,18
5	5,9	3,5	2,2	0	0,20
6	5,7	3,6	2	0	0,19
7	6,2	3,5	2,4	0	0,21
8	6,0	3,5	2,4	0	0,21
9	6,8	4,0	2,6	0	0,20
10	6,2	3,8	2,1	0	0,18

a Q_{ebot} is the surface charge measured at the earth terminal of the bottom unit.
 b Q_{ibot} is the internal charge measured at the earth terminal of the bottom unit.
 c Q_{etop} is the surface charge measured at the line terminal of the top unit.
 d Q_{itop} is the internal charge measured at the line terminal of the top unit.

C.9.4 Calculation performed after five test cycles

C.9.4.1 Calculation of K_{ie}

The elaboration of the data obtained during the first five pollution test cycles gives the following results:

$K_{\text{ieM}} = 0,166$ (i.e. the arithmetical mean of the values K_n)

$\sigma = 0,031$ (i.e. the standard deviation of the values K_n).

The statistical ratio K_{ie} is calculated according to the following equation:

$$K_{\text{ie}} = 0,166 + 2,9 \times 0,031 = 0,256 \quad (\text{C.10})$$

C.9.4.2 Calculation of ΔT_z and of T_{OD}

The calculation of the expected temperature rise in service ΔT_z (see C.8.2) relevant to the different pollution zones are reported in Table C.7.

Table C.7 – Calculated values of ΔT_z and of T_{OD} after 5 cycles for the selected example

Pollution zone	Duration of pollution event	ΔT_z	T_{OD}
	h	K	°C
d	2	26	60
	6	20	60
e	2	59	79
	6	51	71

NOTE Pollution zones correspond to the definition of pollution levels given in Clause 8.3 of IEC TS 60815:2008. No value is available for the new pollution class “a” according to IEC TS 60815-1:2008 and the related RUSCD value according to IEC TS 60815-2:2008, respectively.

Therefore, in the case of application of the surge arrester in pollution zone d, no further pollution test is required and the starting temperature of the operating duty test shall be 60 °C while, for pollution zone e, five more pollution test cycles shall be performed.

C.9.5 Calculation performed after 10 test cycles

C.9.5.1 Calculation of K_{ie}

The elaboration of the data obtained during the first 10 pollution test cycles gives the following results:

$K_{ieM} = 0,182$ (i.e. the arithmetical mean of the values K_n)

$\sigma = 0,028$ (i.e. the standard deviation of the values K_n).

The statistical ratio K_{ie} is calculated according to the formula below:

$$K_{ie} = 0,182 + 2 \times 0,028 = 0,238 \quad (\text{C.11})$$

C.9.5.2 Calculation of ΔT_z and of T_{OD}

The calculation of the expected temperature rise in service ΔT_z (see C.8.2) and of the starting temperature for the operating duty test T_{OD} (see C.8.3) relevant to the different pollution zones (in this case calculation has to be made only for pollution zone e) are reported in Table C.8.

Table C.8 – Calculated values of ΔT_z and of T_{OD} after 10 cycles for the selected example

Pollution zone	Duration of pollution event	ΔT_z	T_{OD}
	h	K	°C
e	2	54	74
	6	47	67

NOTE Pollution zones correspond to the definition of pollution levels given in Clause 8.3 of IEC/TS 60815 Ed.1.0. No value is available for the new pollution class “a” according to IEC TS 60815-1:2008 and the related RUSCD value according to IEC TS 60815-2:2008, respectively.

Therefore, in the case of application of the surge arrester in pollution zone e, the operating duty test shall be conducted starting at 74 °C.

Annex D (informative)

Typical information given with enquiries and tenders

D.1 Information given with enquiry

D.1.1 System data

- Highest system voltage.
- Frequency.
- Maximum voltage to earth under system fault conditions (earth fault factor or system of neutral earthing).
- Maximum duration of the earth fault.
- Maximum value of temporary overvoltages and their maximum duration (earth fault, loss of load, ferro-resonance).
- Insulation level of equipment to be protected.
- Short-circuit current of the system at the arrester location.

D.1.2 Service conditions

For normal conditions, see 5.4.1.

Abnormal conditions:

- a) For ambient conditions, see 5.4.2 and Annex A:
 - for the natural pollution level, see IEC 60071-2.
- b) System:
 - possibility of generator overspeeding (voltage-versus-time characteristics);
 - nominal power frequency other than 48 Hz to 62 Hz;
 - load rejection and simultaneous earth faults. Formation during faults of a part of the system with an insulated neutral in a normally effectively earthed neutral system;
 - incorrect compensation of the earth fault current.

Any other special requirements with respect to service conditions shall be specified and quantified as far as possible

D.1.3 Arrester duty

- a) Connection to system:
 - phase to earth;
 - neutral to earth;
 - phase to phase.
- b) Type of equipment being protected:
 - transformers (directly connected to a line or via cables);
 - rotating machines (directly connected to a line or via transformers);
 - reactors;
 - HF-reactors;
 - other equipment of substations;
 - gas-insulated substations (GIS);
 - capacitor banks;

- cables (type and length), etc.

Maximum length of high-voltage conductor between arrester and equipment to be protected (protection distance).

D.1.4 Characteristics of arrester

- a) Continuous operating voltage.

Rated voltage.

Steep current impulse residual voltage.

Standard nominal discharge current and residual voltages.

Switching current impulses and residual voltages.

For 10 kA and 20 kA arresters, repetitive charge transfer rating and thermal energy rating.

Short circuit rating.

Length and shape of creepage distance of arrester housing. Selected on the basis of service experience with surge arresters and/or other types of equipment in the actual area.

D.1.5 Additional equipment and fittings

- a) Metal-enclosed arrester.

Type of mounting: pedestal, bracket, hanging (in what position) etc. and if insulating base is required for connection of surge counters. For bracket-mounted arresters whether bracket is to be earthed or not.

Mounting orientation if other than vertical.

Earth lead disconnector/fault indicator if required.

Cross-section of connection lead.

D.1.6 Any special abnormal conditions

Any other special requirements in respect to service conditions shall be specified and quantified as far as possible

D.2 Information given with tender

- a) All items from D.1.4 and D.1.5.

In addition:

- reference current and voltage at ambient temperature;
- power-frequency voltage versus time characteristics (see 8.8);
- lightning impulse residual voltage at 0,5, 1 and 2 times the nominal discharge current. If the complete arrester acceptance test cannot be carried out at one of those currents, the residual voltage shall in addition be specified for current in the range of 0,01 to 0,25 times the nominal discharge current, see 6.3 and 8.3;
- pressure-relief function;
- clearances;
- mounting specifications;
- possibilities of mounting, drilling plans, insulating base, bracket;
- type of arrester terminals and permissible conductor size;
- maximum permissible length of lead between arrester and surge counter, and between surge counter and earth;
- dimensions and weights;
- cantilever strength.

Annex E (informative)

Ageing test procedure – Arrhenius law – Problems with higher temperatures

The Arrhenius law has provided good confidence on life expectancy of metal-oxide blocks. It is the basis for the present accelerated ageing test (see 8.4). The upper limit for the normal ambient air temperature for metal-oxide arresters according to this standard is 40 °C. For some arresters, such as dead-front or liquid-immersed, the upper limit of the ambient temperature of the medium in which the arrester operates is higher (respectively +65 °C and +95 °C).

The accelerated rate of ageing is reasonably estimated by the acceleration factor $AF_T = 2,5(\Delta T / 10)$ where ΔT is the difference between the test temperature and the upper limit of the ambient temperature associated with the product.

Table E.1 provides examples of the minimum demonstrated lifetime prediction given by a 1 000 h ageing test at 115 °C, as described in 8.4.

Table E.1 – Minimum demonstrated lifetime prediction

Upper limit of ambient temperature °C	Minimum demonstrated lifetime prediction Years
40	110
65	11
95	0,7

NOTE The minimum demonstrated lifetime prediction is obtained by multiplying the 1 000 h by the acceleration factor.

The 1 000 h test does not give enough confidence in minimum lifetime expectancy for the highest ambient temperature. To improve the situation, increasing the test temperature, test voltage or test duration could be considered.

In general, it is not acceptable to increase the test temperature above 115 °C as it may change the physics of ageing, rendering the Arrhenius law non-applicable. Increasing the test voltage is not acceptable either, as this factor is not established as an acceleration factor.

The only remaining possibility is to increase the test duration. Table E.2 shows the relationship between test duration and the equivalent time for different upper limits of the ambient temperature.

**Table E.2 – Relationship between test durations at 115 °C and equivalent time
at upper limit of ambient temperature**

Upper limit of ambient temperature °C	Test duration at 115 °C h	Equivalent time at upper limit of ambient temperature Years
40	1 000	110
65	2 000	22
95	7 000	5

If these equivalent times at continuous use temperature are not acceptable to the user, the testing time may be increased after agreement between the manufacturer and the user. Alternatively, if it can be demonstrated that the Arrhenius law still applies, a higher temperature may be used after agreement between the manufacturer and the user.

Annex F (informative)

Guide for the determination of the voltage distribution along metal-oxide surge arresters

F.1 General

The voltage distribution along a metal-oxide surge arrester is governed by the capacitances and the resistances of the MO resistors, the stray capacitances from the MO resistor column and metal flanges to earthed and live parts, and the boundary conditions (applied voltage, proximity and voltage applied to other objects in the vicinity). Stray capacitances result in uneven voltage distribution along the MO resistor column, with the maximum voltage stress typically appearing in the upper part of the arrester.

The test voltage U_{ct} for the accelerated ageing test (see 8.4) is found from the maximum voltage stress appearing along the MO resistor column. The voltage distribution may be determined by means of commonly available computer programs for calculation of electric fields and circuits. The results of such calculations are, however, dependent on the representations of the surge arrester and the prevailing boundary conditions. The aim of this annex is to provide basic guidance on the representation of the surge arrester geometry and its electrical characteristics, along with general information on the modelling of the boundary conditions.

Due to the complexities and variations in surge-arrester installations, simplified representations of arrester geometries and boundary conditions are often needed to facilitate computations of voltage distribution for a given arrester design. Different degrees of simplification of the arrester geometry are discussed in F.2, and a simplified representation of the boundary conditions for three-phase installations is proposed in F.3. For modelling of other surge arrester designs, for example, GIS arresters, no guidance is given since geometries and boundary conditions are normally well defined.

The calculation procedure may be carried out in two different ways depending on the degree of complexity in the electrical representation of the MO resistor column, as described in F.4.

Examples of electric field calculations, representing a typical outdoor arrester installation, are presented in F.5.

F.2 Modelling of the surge arrester

Since the stray capacitances are important to the voltage distribution along the MO resistor column, the influence of various simplifications in the surge arrester model must be considered with respect to these capacitances. A series of electric field calculations, carried out using an axi-symmetric representation of the arrester, have given the following results with respect to the degree of simplification to the arrester model.

- The MO resistor column, including any metal spacers, should be represented by its actual dimensions and permittivity. An "equivalent" MO resistor column of larger diameter, and correspondingly decreased permittivity, results in a higher maximum voltage stress. Similarly, replacing the actual MO resistor/spacer column with an "equivalent" column without spacers, and with a correspondingly increased permittivity, also results in a higher maximum voltage stress.
- The housing may be represented by a cylinder having an inner diameter equal to the inner diameter of the actual housing and radial thickness equal to the wall thickness of the actual housing. The permittivity should be that of the actual housing material, for example,

porcelain or polymer. The sheds may be omitted since they have a negligible influence on the voltage distribution.

- The material between the insulator and the MO resistor column (for example, gas or any filling material) should be modelled with its actual dimensions and permittivity.
- The metal flanges may be represented by cylinders having diameters equal to the maximum outer diameter of the actual flanges and heights equal to the heights of the actual flanges.
- The grading rings may be represented by toroids of the same dimensions and physical location as the toroidal elements of the actual grading rings. Omitting the support members, which it is not possible to represent in an axi-symmetric model, may result in an over-estimation of the maximum voltage stress. The representation of the support members in axi-symmetric and three-dimensional models is discussed further in F.5.
- The pedestal, if used, may be represented by a cylinder having a cross-sectional area sufficient to contain the maximum cross-section of the actual pedestal and a height equal to the actual pedestal. Reducing the height of the pedestal results in a higher maximum voltage stress in the upper part of the arrester.
- The high-voltage lead should be represented by a vertical cylindrical conductor of a diameter not greater than the diameter of the actual line lead. Omitting the high-voltage lead results in a higher maximum voltage stress in the upper part of the arrester.

F.3 Modelling of the boundary conditions

For surge arresters in typical three-phase outdoor installations, for example, in substations, the boundary conditions are determined by the distances to earthed structures and adjacent phases. In general, this is a truly three-dimensional electric field problem, where both the magnitude and the phase angle of the applied voltages need to be considered.

The calculation procedure may be simplified by reducing the original three-phase, three-dimensional (3D) configuration to an equivalent single-phase, axi-symmetric configuration, which can be treated by generally available two-dimensional (2D) calculation software. The equivalent axi-symmetric configuration is obtained by modelling the arrester in the centre of an earthed cylinder having a radius determined by the minimum phase-to-earth clearance recommended by the manufacturer. The height of the earthed cylinder should be 1,5 times the total height of the arrester plus the pedestal.

NOTE The equivalent axi-symmetric configuration is valid for a typical three-phase installation with the three arresters positioned on a straight line in parallel to an earthed structure, at a distance equal to the minimum recommended phase-to-earth clearance and with the minimum recommended phase-to-phase clearance, as shown in Figure F.1.

F.4 Calculation procedure

The calculation procedure may be performed in two different ways, as described in F.4.1 and F.4.2, depending on how the electrical properties of the MO resistor column are represented. The exclusively capacitive representation (see F.4.1) will always give conservative results in comparison with the combined capacitive/resistive representation (see F.4.2), which gives lower but more realistic stresses. Any other calculation procedure that leads to the same or more conservative results may also be used.

F.4.1 Capacitive representation of the MO resistor column

In this case, the MO resistor column is represented exclusively by its capacitance (permittivity), neglecting the influence of the resistive characteristic. This conservative approximation is justified as long as the calculated maximum voltage stress corresponds to a test voltage U_{ct} that is below the reference voltage of the MO resistors. The maximum voltage stress should be determined over an axial distance not exceeding 3 % of the total arrester length.

F.4.2 Capacitive and resistive representation of the MO resistor column

Here, the MO resistor column is represented by its capacitance in parallel to its non-linear resistive characteristic. This representation of the MO resistor column results in a more realistic calculated maximum voltage stress compared to the case with the more conservative capacitance-only representation.

Firstly, a capacitive electric field calculation is carried out to determine the stray capacitances to earth. Secondly, the resistive characteristic is introduced and the voltage distribution is calculated by means of electric circuit analysis. In general, an iterative calculation process is required due to the temperature dependence of the resistance. However, as a reasonably conservative approximation, the constant resistive characteristic at +20 °C should be used.

Figure F.2 shows a simplified multi-stage equivalent circuit of an arrester, which may be used with an electric circuit analysis program to determine the voltage distribution considering both capacitive and resistive effects. The arrester is modelled by the voltage-dependent resistances, the capacitances representing the MO resistor column and the stray capacitances to earth. Each stage of the equivalent circuit may represent one single metal-oxide MO resistor, as the extreme case, or a section of the MO resistor column. The length of each section should not exceed 3 % of the total arrester length.

With the node voltages obtained by an exclusively capacitive electric field calculation in accordance with F.4.1, the stray capacitances to earth may be derived as follows:

$$C_{e,x} = \frac{(U_{x+1} - U_x) \times C_{MO,x+1} - (U_x - U_{x-1}) \times C_{MO,x}}{U_x} \quad (x = 1, 2, \dots, n - 1)$$

where

- U_x is the voltage at node x ;
- $C_{MO,x}$ is the capacitance of section x ;
- $C_{e,x}$ is the stray capacitance to earth at node x ;
- n is the number of sections.

NOTE These calculations may result in negative values in certain cases. This is a consequence of the chosen model, with all the stray capacitances connected to earth. By using other models with different representations of stray capacitances, negative values may be avoided.

F.4.3 Determination of U_{ct}

The ratio of U_{ct} to U_c in the accelerated ageing test (see 8.4) is determined by dividing the calculated maximum voltage stress along the total length of the MO resistor column (energized at $U = U_c$), by the mean voltage stress along the same length.

F.5 Example calculations

Example calculations of the axial voltage distribution for a typical metal-oxide surge arrester were carried out using two different computation methods: the finite element method (FEM) and the boundary element method (BEM). The finite element method was used only for 2D computations, while the boundary element method was used for both 2D and 3D computations.

The example calculations were carried out using both the capacitance-only representation, as well as the capacitive/resistive representation. The arrester model used in the calculations is a simplified representation of a typical multi-unit arrester with porcelain housing (see Figure F.3a).

F.5.1 Modelling of the arrester and the boundary conditions

The simplifications in the modelling of the arrester were made in accordance with F.2 except for the grading rings, where different approaches were applied as described below.

It was assumed that the typical arrester is equipped with one grading ring and four support members for the ring, as shown in Figure F.3a. The different representations of the grading ring and its supports, corresponding to different degrees of simplification, are shown in Figure F.3b. The first model, using one ring without supports, was used in axi-symmetric 2D and 3D computations (cases A and D, respectively). The second model was used to study the feasibility of adding a "virtual" grading ring in axi-symmetric calculations to simulate the influence of the grading ring supports. Both 2D and 3D computations were carried out (cases B and E, respectively). The third model is a three-dimensional representation of the grading ring including the supports, used only for 3D computation (case F).

The relative permittivity of the "equivalent" MO resistor columns was chosen as 800, while the relative permittivity of the porcelain housings was set equal to five. The boundary conditions were chosen in accordance with F.3, i.e. the arrester is positioned in an earthed cylinder with a radius determined by the minimum clearance requirement.

F.5.2 Resistive effects of the metal-oxide MO resistors

The resistive effect of the metal-oxide MO resistors was introduced in accordance with F.4.2. The non-linear resistive characteristic used in the computations is shown in Figure F.4. The resistive effect was investigated in 2D computations with the "virtual" grading ring included (case C) for comparison with case B, and in 3D computations with the supports included (case G) for comparison with case F.

Due to the non-linear effect introduced by the resistive characteristic, it is necessary to carry out the combined capacitive/resistive calculations at a given voltage level. For the example calculations, it was assumed that $U_c = 333$ kV r.m.s (471 kV peak) with a frequency of 50 Hz.

F.5.3 Results and conclusions from electric field calculations

The calculated maximum voltage stresses on the metal-oxide MO resistor column in each unit are summarised in Table F.1 for the different cases, A to G. The voltage stress is expressed in percent of U_c per metre length of the MO resistor column, assuming that the arrester is energized at $U_c = 100$ %, yielding a mean voltage stress of 34,7 %/m. The results in Table F.1 are average values from several computations using different FEM and BEM computation software. Deviations of 1 %/m to 2 %/m may typically be expected. The maximum stress among the three units is also expressed in terms of the ratio U_{ct}/U_c for determination of the test voltage in the accelerated ageing test (see F.4.3) Detailed example calculation results showing the voltage stress along the arrester column are presented in Figure F.5 for case B.

In general, it can be concluded that 2D and 3D computations give similar results (case A versus D, and case B versus E). The computation time is, however, several orders of magnitude longer when using 3D computation methods.

With reference to the various simplifications in the modelling of the arrester discussed in previous subclauses, some general conclusions can be drawn from Table F.1:

- the calculated voltage stress in the top unit is significantly lower if the grading ring supports are included in the 3D computation (case A and D versus case F);
- the calculated stress is further reduced in both 2D and 3D computations if the resistive effects are considered (case B versus C, and case F versus G);
- the effect of the grading ring supports may be simulated by introducing a "virtual" grading ring in the axi-symmetric model (case B versus F, and case C versus G). However, no general rules for proper sizing or placement of the "virtual" ring can be given on the basis of these results.

Table F.1 – Results from example calculations

Surge arrester model	Case	Maximum voltage stress			Maximum ratio U_{ct}/U_c
		Top unit	Middle unit	Bottom unit	
		% / m	% / m	% / m	p.u.
2D computations					
One grading ring	A	50	39	26	1,44
Two grading rings	B	44	40	27	1,27
Two grading rings, resistive effects	C	41	39	29	1,18
3D computations					
One grading ring	D	50	37	27	1,44
Two grading rings	E	43	38	28	1,24
One grading ring with four supports	F	44	39	27	1,27
One grading ring with four supports, resistive effects	G	41	39	28	1,18

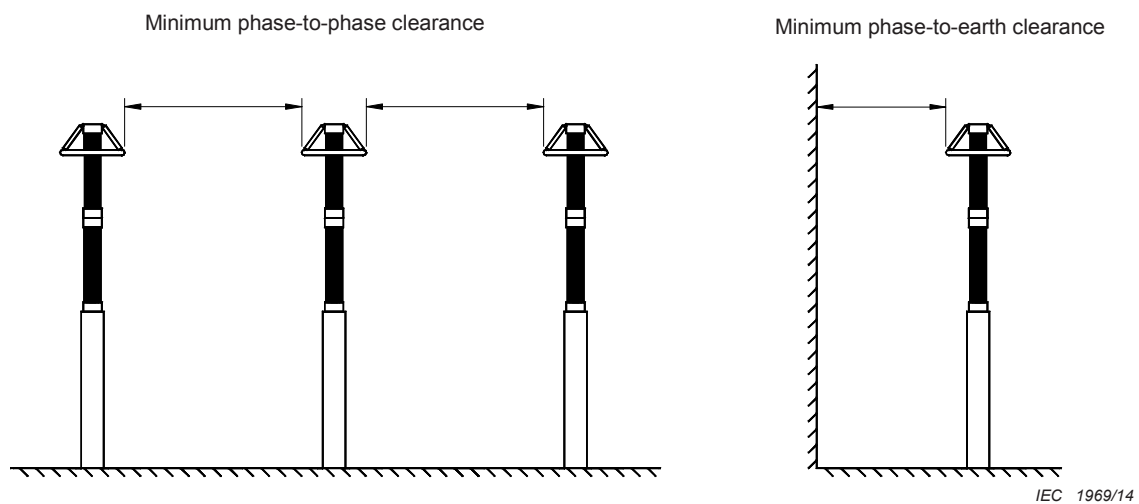
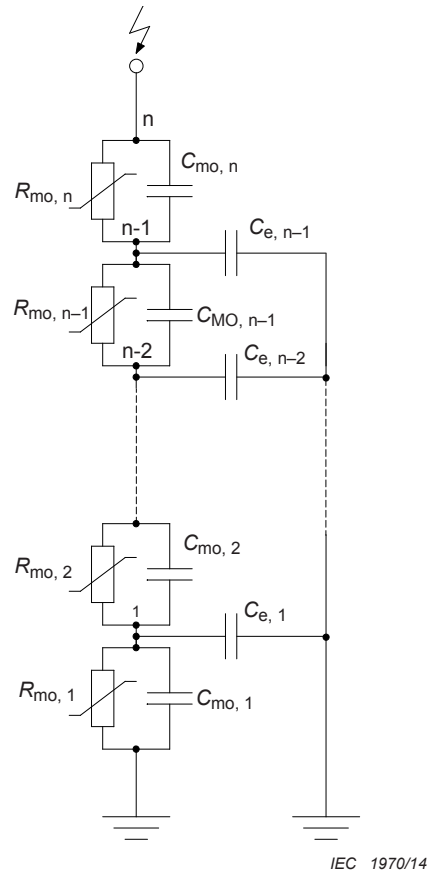
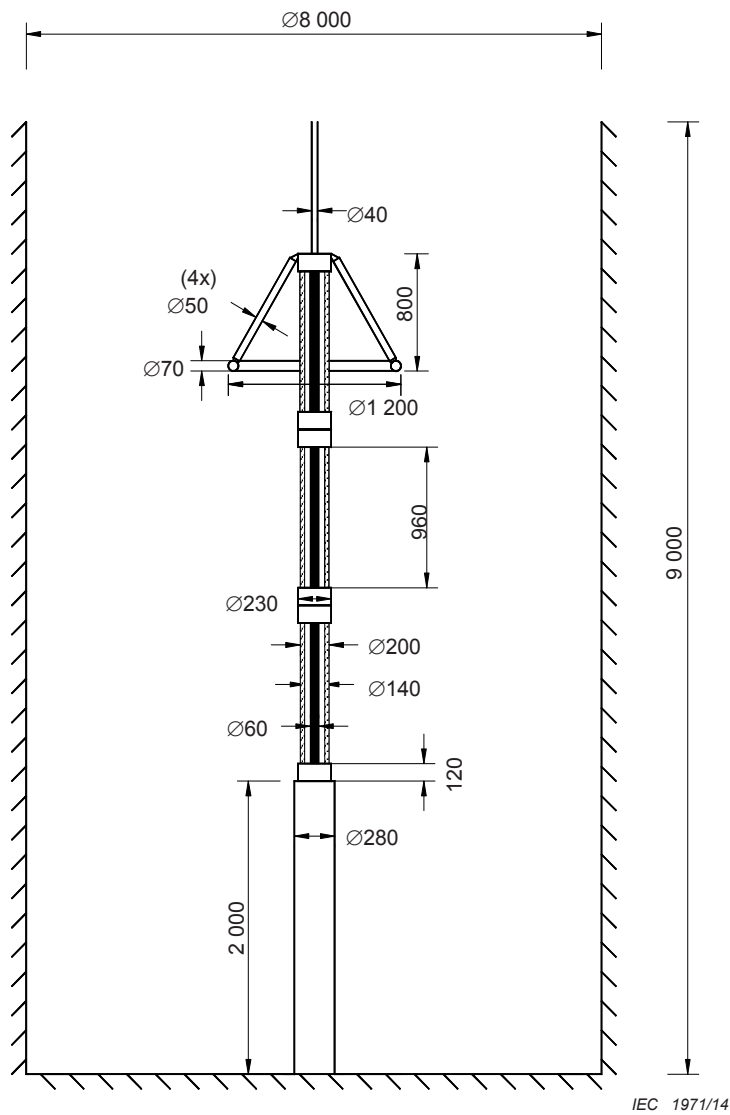

Figure F.1 – Typical three-phase arrester installation

**Key**

- $R_{mo, x}$ Voltage-dependent resistance of section x
 $C_{mo, x}$ Capacitance of section x
 $C_{e, x}$ Stray capacitance to earth at node x
 n Number of sections

Figure F.2 – Simplified multi-stage equivalent circuit of an arrester



IEC 1971/14

Dimensions in millimetres

Figure F.3a – Simplified model of multi-unit arrester

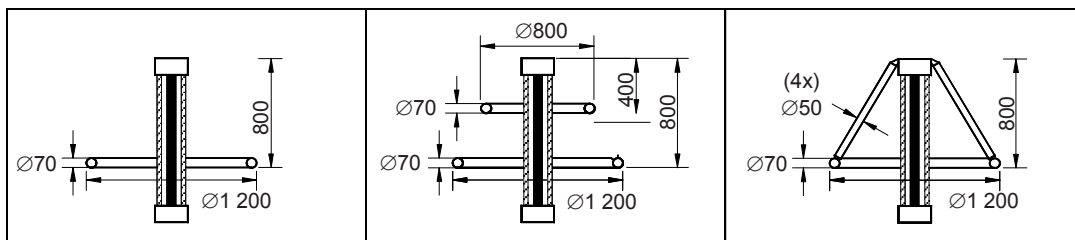

IEC 1972/14

Case A, D

Case B, C, E

Case F, G

Dimensions in millimetres

Figure F.3b – Different representations of the grading ring

Figure F.3 – Geometry of arrester model

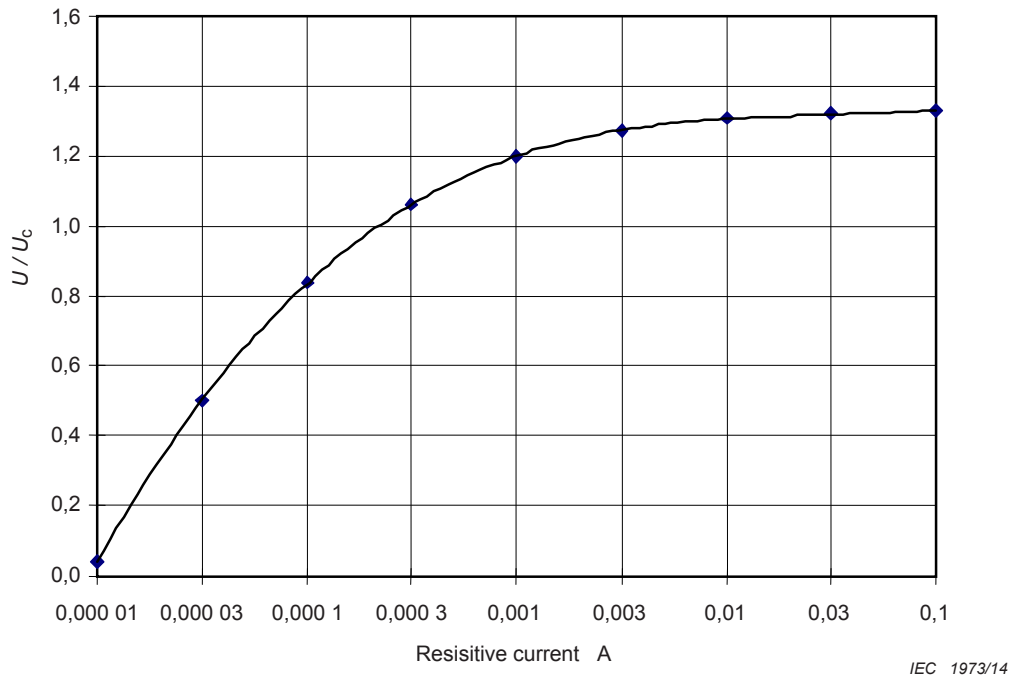

Figure F.4 – Example of voltage-current characteristic of MO resistors at +20 °C in the leakage current region

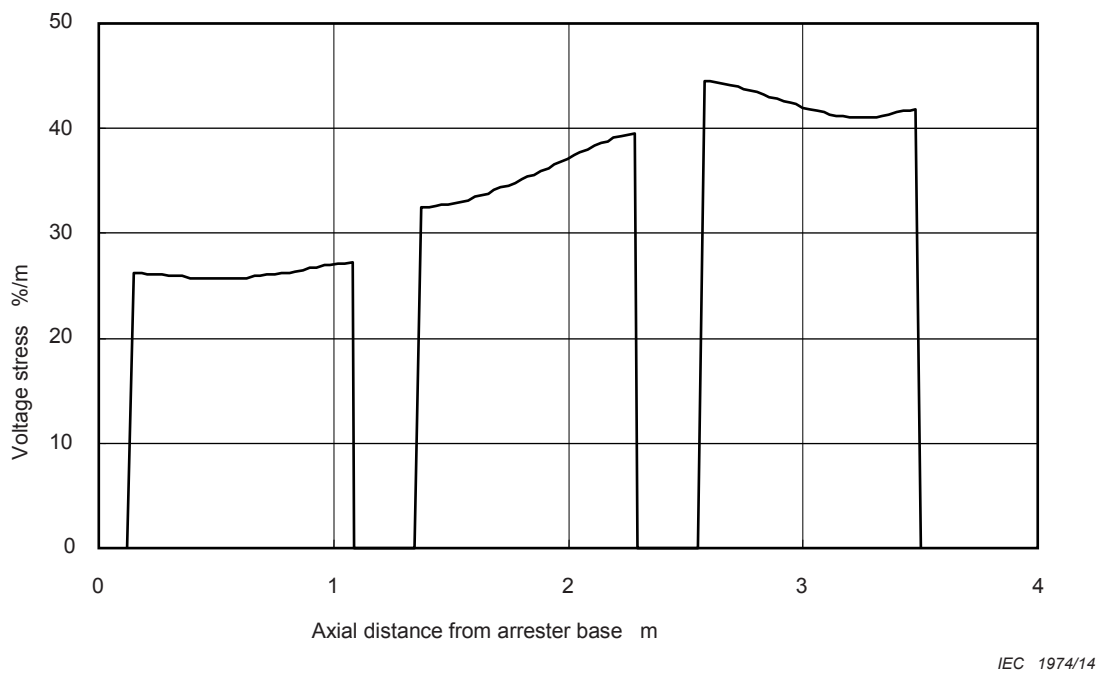

Figure F.5 – Calculated voltage stress along the MO resistor column in case B

Annex G (normative)

Mechanical considerations

G.1 Test of bending moment

In the case of a multi-unit arrester, each unit shall be tested with the bending moment according to Figure G.1. The required load is calculated as given below. If the units differ only in length, but are otherwise identical from material and design, it is not necessary to test each unit.

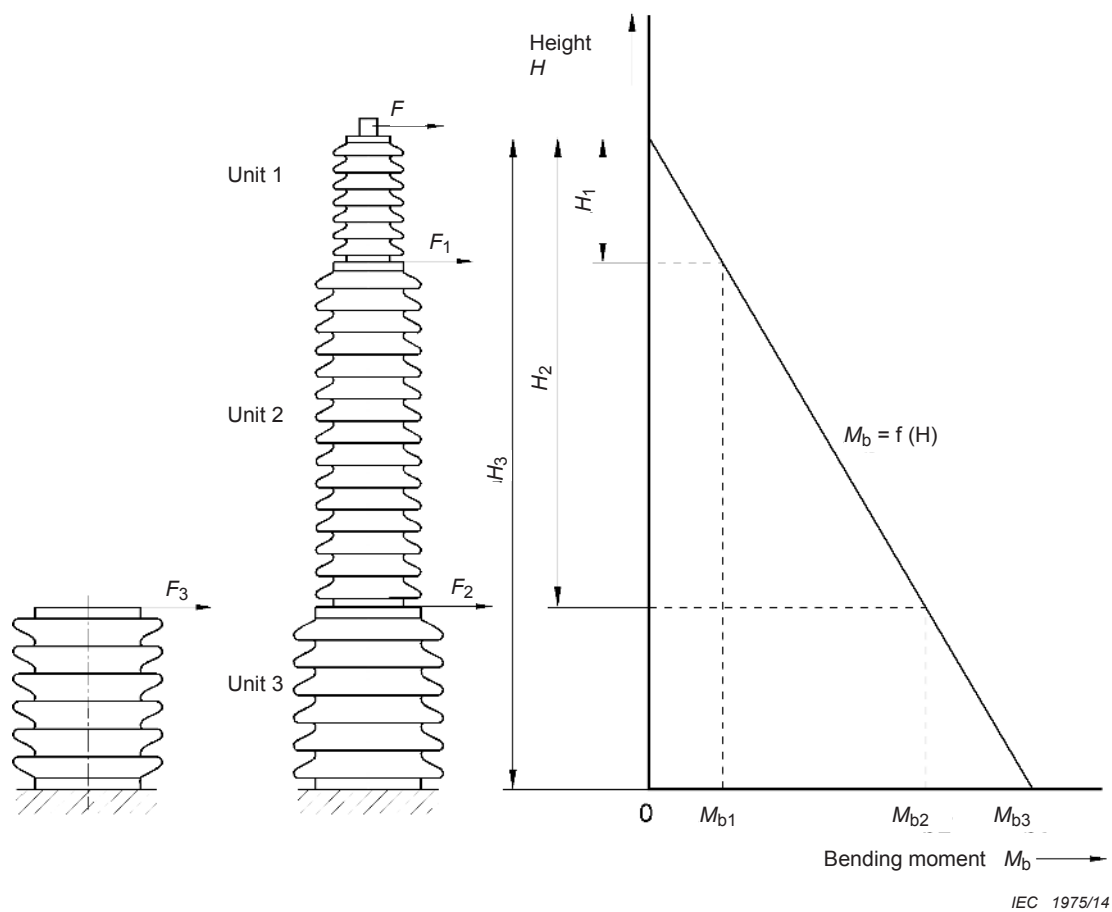

Figure G.1 – Bending moment – multi-unit surge arrester

Testing the complete arrester, the moment affecting the bottom flange is $M_{b3} = F \times H_3$.

The moment affecting the top flange of the bottom unit is $M_{b2} = F \times H_2$.

If one unit is tested separately (example for unit 3), the test force F_2 for the test of the bottom flange of unit 3 is as follows:

$$F_2 \times (H_3 - H_2) = F \times H_3;$$

$$F_2 = \frac{F \times H_3}{(H_3 - H_2)}$$

The test of the top flange of unit 3 shall be performed with the unit in reversed position. Test force F_3 for the test of the top flange of unit 3 is as follows:

$$F_3 \times (H_3 - H_2) = F \times H_2$$

$$F_3 = \frac{F \times H_2}{(H_3 - H_2)}$$

G.2 Seismic test

If, after agreement between the manufacturer and the user, seismic tests are performed, relevant standards are:

- IEC 62271-300
- IEC 62271-207
- GB 50260
- JEAG 5003
- IEEE 693
- IEC/TS 61463

In order to detect any significant changes in the arrester performance before and after the seismic test the following tests shall be performed:

- Measurement of reference voltage
- Internal partial discharge test
- Leakage check (for arresters with an enclosed gas volume and separate sealing system)

G.3 Definition of mechanical loads

Figure G.2 indicates the relationships between mechanical load ratings.

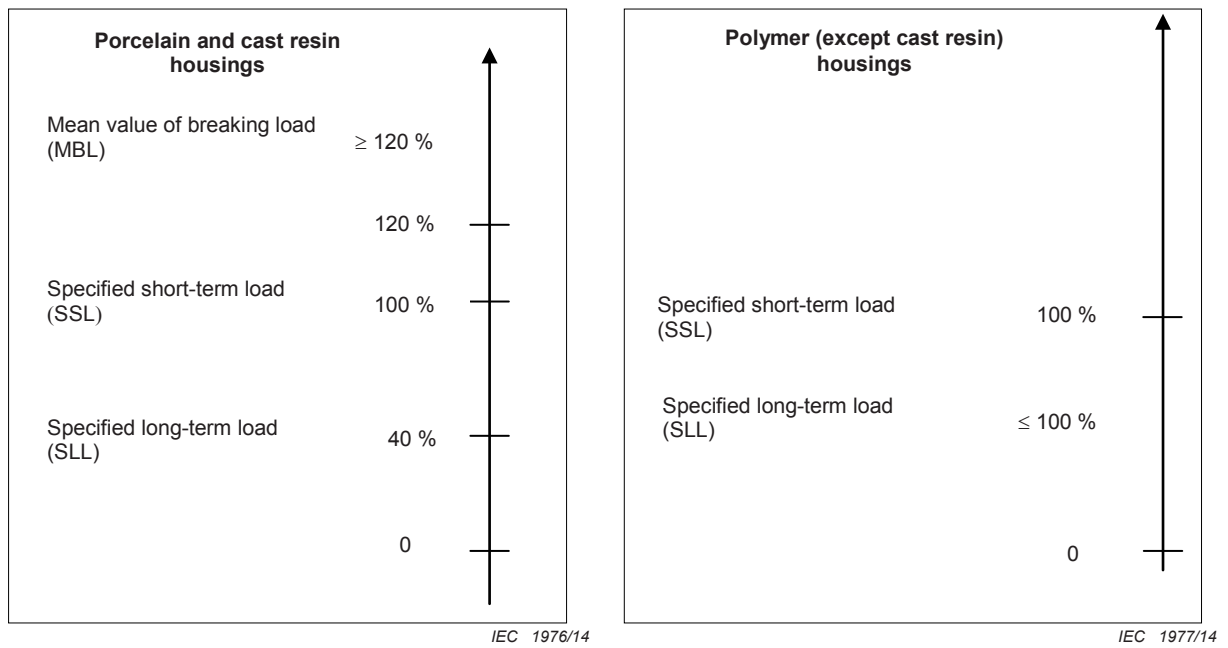

Figure G.2 – Definition of mechanical loads

G.4 Definition of seal leak rate

Figure G.3 schematically represents an arrester unit.

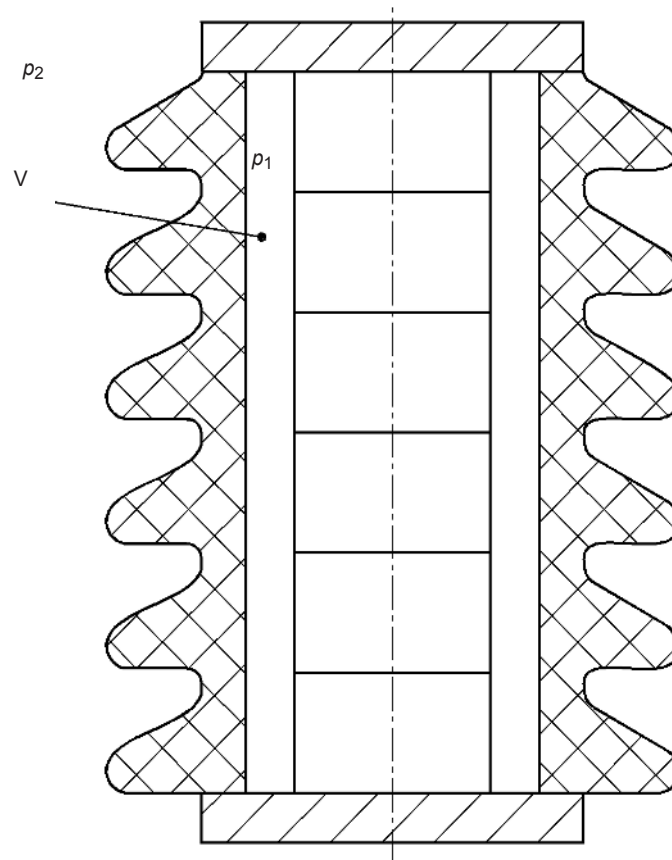

Figure G.3 – Surge arrester unit

The seal leak rate specifies the quantity of gas per unit of time which passes the seals of the housing at a pressure difference of at least 70 kPa. If the efficiency of the sealing system depends on the direction of the pressure gradient, the worst case shall be considered.

$$\text{Seal leak rate} = \frac{\Delta p_1 \times V}{\Delta t} \text{ at } |p_1 - p_2| \geq 70 \text{ kPa and at a temperature of } +20 \text{ }^\circ\text{C} \pm 15 \text{ K,}$$

where

$$\Delta p_1 = p_1(t_2) - p_1(t_1);$$

$p_1(t)$ is the internal gas pressure of the arrester housing as a function of time (Pa);

p_2 is the gas pressure exterior to the arrester (Pa);

t_1 is the start time of the considered time interval (s);

t_2 is the end time of the considered time interval (s);

$$\Delta t = t_2 - t_1;$$

V is the internal gas volume of the arrester (m^3).

G.5 Calculation of wind-bending-moment

Figure G.4 schematically represents an assembled arrester.

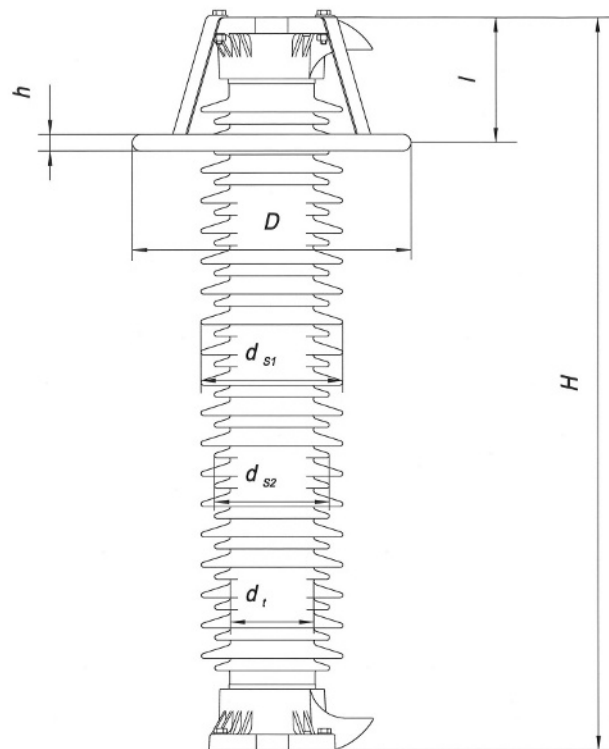

IEC 1979/14

Figure G.4 – Surge-arrester dimensions

The wind-bending moment is given by

$$M_w = P \times H \times d_a \times C \times H/2 + P \times D \times h \times (H - l)$$

where

$$P = (P_1/2) \times V^2;$$

$$d_a = (2d_t + d_{s1} + d_{s2})/4 \text{ as per IEC 60815-2 } (d_{s1} = d_{s2} \text{ for non-alternating sheds})$$

M_w is the bending moment caused by the wind (Nm);

H is the height of the arrester (m);

d_a is the mean value of the insulator diameter (m);

h is the thickness of the grading ring (m);

D is the diameter of the grading ring (m);

l is the grading ring distance to the top (m);

C is the coefficient of drag for cylindrical parts; equal to 0,8;

P is the dynamic pressure of the wind (N/m²);

P_1 is the density of air at 1,013 bar and 0 °C; equal to 1,29 kg/m³;

V is the wind velocity (m/s).

G.6 Procedures of tests of bending moment for porcelain/cast resin and polymer-housed arresters

A flow chart of the procedures is shown in Figure G.5.

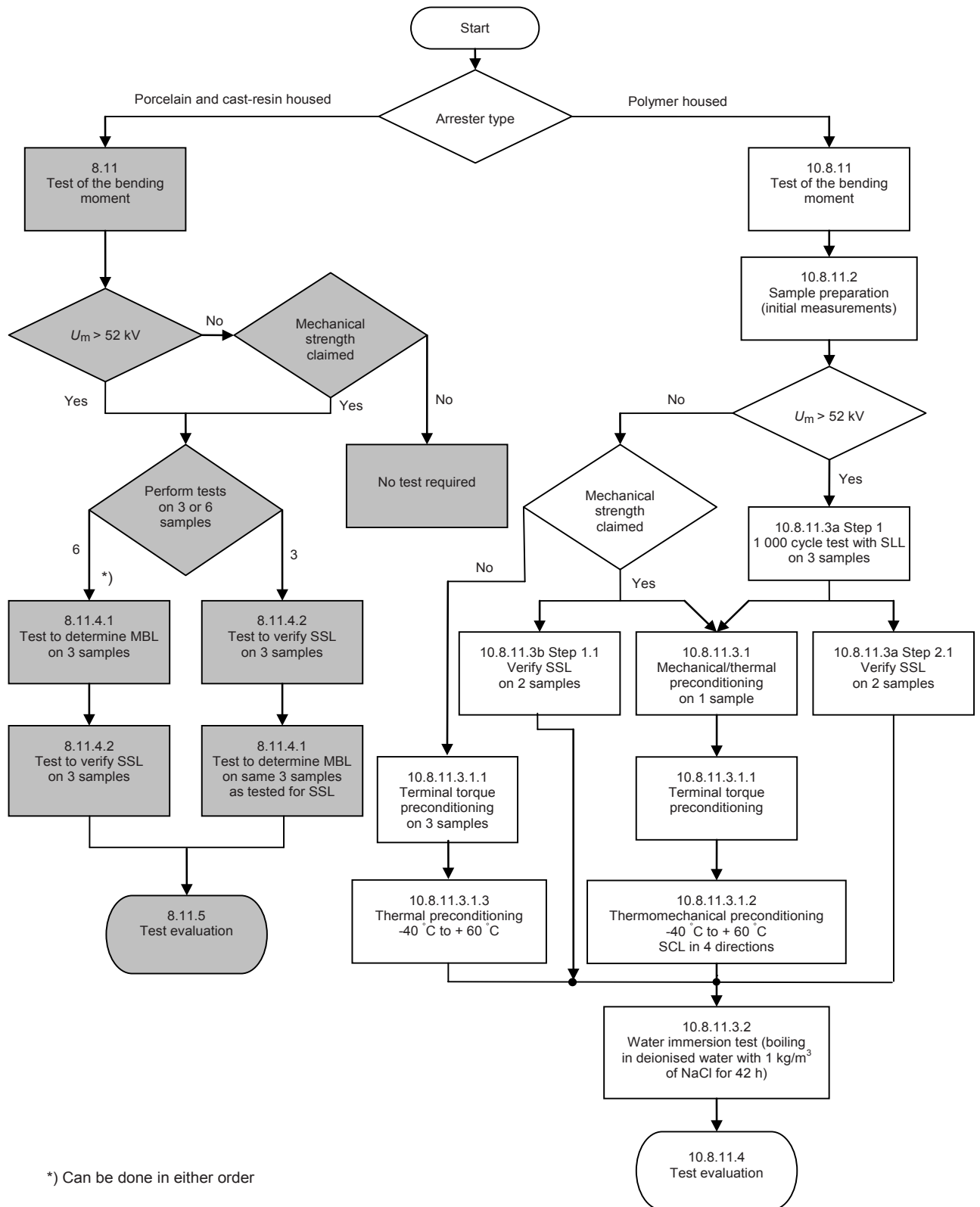

Figure G.5 – Flow chart of bending moment test procedures

Annex H (normative)

Test procedure to determine the lightning impulse discharge capability

H.1 General

This test procedure applies to surge arresters used on lines (NGLA) with system voltages $U_s > 52$ kV to improve the lightning performance of such lines. In general, these arresters are subjected to higher energy and current stresses caused by lightning than arresters installed in stations with effective lightning protection on incoming lines. In addition, the anticipated current waveform for decisive cases, with a duration of several tens of microseconds for arresters applied on shielded lines and several hundreds of microseconds for arresters on unshielded lines, considerably differs from waveforms specified in the operating duty test and in the long-duration current impulse test.

An impulse duration of 200 μ sec has been considered as a suitable compromise to cover both the typical applications and the effect of multiple strokes.

Arresters intended for this application, therefore, shall be tested in accordance with the lightning impulse discharge capability test to verify the rated lightning impulse discharge capability of the arrester.

H.2 Selection of test samples

Three samples shall be tested. These samples shall include complete arresters, arrester sections or resistive elements. They shall not have been subjected to any previous tests except as necessary for evaluation purposes of this test.

The samples to be chosen for the lightning impulse discharge capability test shall have a residual voltage at nominal discharge current at the highest end of the variation range declared by the manufacturer. Furthermore, in the case of multi-column arresters, the highest value of uneven current distribution shall be considered. In order to comply with these demands the following shall be fulfilled.

- a) The ratio between the rated voltage of the complete arrester to the rated voltage of the section is defined by n . The volume of the MO resistor elements used as test samples shall not be greater than the minimum volume of all MO resistor elements used in the complete arrester divided by n .
- b) The residual voltage of the test section should be equal to $k \cdot U_r / n$, where k is the ratio between the maximum residual voltage at standard nominal discharge current of the arrester and its rated voltage. In the case where $U_{res} > k \cdot U_r / n$ for an available test sample the factor n has to be decreased correspondingly. If $U_{res} < k \cdot U_r / n$, the section is not allowed to be used.
- c) For multi-column arresters, the distribution of the current between the columns shall be measured at the impulse current used for the current distribution test (see 9.1e)). For each test sample, the ratio of maximum current in any column to the average current, kA, is determined and compared with the maximum ratio, K_m , specified by the manufacturer. The highest current value in any of the columns shall not be higher than that given by K_m .

H.3 Test procedure

Before commencing the tests, the lightning impulse residual voltage at nominal discharge current of each test sample shall be measured for evaluation purposes.

Each lightning impulse discharge capability test shall consist of 18 discharge operations divided into six groups of three operations. Intervals between operations shall be 50 s to 60 s and between groups such that the sample cools to near ambient temperature.

Following the 18 discharge operations and after the sample has cooled to near ambient temperature, the residual voltage tests, which were made before the test, shall be repeated for comparison with the values obtained before the test and the values shall not have changed by more than 5 %.

Visual examination of the test samples after the test shall reveal no evidence of puncture, flashover, cracking or other significant damage of the MO resistors.

In case of a design where the MO resistors cannot be removed for inspection, an additional impulse shall be applied after the sample has cooled to ambient. If the sample has withstood this 19th impulse without damage (checked by the oscillographic records), then the sample is considered to have passed the test.

NOTE With respect to possible changes in the low current range due to lightning impulse discharges, this is considered to be sufficiently covered by present operating duty tests.

H.4 Test parameters for the lightning impulse discharge capability test

The current peak value is selected by the manufacturer to obtain a particular discharge energy and charge. The energy shall not be higher than the specified thermal energy rating, W_{th} . If this is not the case, the operating duty test shall be repeated with increased energy to cover the claimed energy.

The current impulse shape shall be according to 3.32. The peak of any opposite polarity current wave shall be less than 5 % of the peak value of the current.

The current peak value of each impulse on each test sample shall lie between 100 % and 110 % of the selected peak value.

H.5 Measurements during the lightning impulse discharge capability test

The energy, charge and peak current shall be reported for each impulse as well as the duration of time during which the instantaneous value of the impulse current is greater than 5 % of its peak value. Oscillograms of the typically applied voltage and current waveforms and dissipated energy shall be supplied on the same time base.

H.6 Rated lightning impulse discharge capability

The average peak current, charge and energy shall be calculated from the 18 discharge operations. The average energy shall be divided by the rated voltage of the sample to obtain the specific energy. For multicolumn arresters, the peak current, charge and energy for each test sample shall be multiplied by the factor kA/K_m before the average value is determined.

The rated lightning impulse discharge capability of the arrester is the combination of the following:

- a) the lowest average peak current for any of the 3 test samples;

- b) an energy value selected from the list of K.7 lower than, or equal to, the lowest specific energy for any of the 3 test samples;
- c) a charge value selected from the list of K.8 lower than, or equal to, the lowest average charge for any of the 3 test samples.

H.7 List of rated energy values

The following values, expressed in kJ/kV of rated voltage, are standardized as rated energy values: 1; 1,5; 2; 2,5; 3; 3,5; 4; 4,5; 5; 6; 7; 8; 9; 10; 11; 12; 13; 14; 15; 16; 17; 18; 19; 20.

H.8 List of rated charge values

The following values, expressed in coulombs, are standardized as rated charge values: 0,4; 0,6; 0,8; 1; 1,2; 1,4; 1,6; 1,8; 2; 2,4; 2,8; 3,2; 3,6; 4; 4,4; 4,8; 5,2; 5,6; 6; 6,4; 6,8; 7,2; 7,6; 8; 8,4; 8,8; 9,2; 9,6; 10.

Annex I (normative)

Determination of the start temperature in tests including verification of thermal stability

This procedure is necessary only for arresters intended for use on systems of $U_s > 800$ kV.

A complete arrester shall be tested. The arrester shall be installed under as realistic conditions as possible taking into account an actual 3-phase installation. Since the testing most probably has to be performed single-phase a realistic installation may be established by calculations comparing test and actual installation to obtain approximately the same voltage distribution along the arrester under the test conditions as under field conditions.

The ambient temperature during the test shall not vary by more than ± 5 K. The temperature of at least two MO resistors in each column and in each arrester unit shall be measured in the units next to a grading ring (below and above), in all other units at least one. If two measuring points are used they shall be located approximately 1/3 and 2/3 of the length from top of the unit. In the case with one measuring point it shall be located approximately 1/3 of the length from the top of the unit. If more than two measuring points are used they shall be evenly distributed along the length of the unit.

To determine the start temperature in tests including verification of thermal stability the following step-by-step procedure shall be used.

- 1) Measure the reference voltage, U_{refa} , of the complete arrester and determine the ratio, k , to the minimum declared reference voltage, U_{refmin} , by the manufacturer. U_{refa} shall not be less than U_{refmin} .
- 2) Energize the arrester at a voltage U_{ca} equal to k times the claimed U_c for the arrester until steady state temperatures are reached within the arrester.
- 3) Determine the average arrester temperature in steady state, T_{ar1} . The average temperature is determined from the measuring points by weighting with the ratio of the rated voltage of the unit over the rated voltage of the complete arrester (see Annex J). For multi-column designs it is essential to ensure that the different columns have approximately the same power losses. The reference voltage of the columns, measured before start of the test, therefore, shall not deviate by more than $\pm 1\%$ and the temperature increase shall not deviate by more than $\pm 20\%$ between the different columns.
- 4) At the same ambient temperature as for the test on the complete arrester energize a thermally correct section (verified as per Annex B) of the arrester at a voltage, U_{cs} , which results in the same average temperature ($+5/-0$ K) as for the complete arrester. This voltage may be significantly higher than an equivalent U_c determined from the ratio of reference voltage of the unit to the reference voltage of the complete arrester due to effect of non-linear voltage distribution. Thereafter, place the thermal unit in still air ambient temperature of 40 °C and energize it at U_{cs} until steady state temperatures of the MO resistors are reached. For multi-column designs it is essential to ensure that the different columns have approximately the same power losses. The reference voltage of the columns, measured before start of the test, therefore, shall not deviate by more than $\pm 1\%$ and the temperature increase shall not deviate by more than $\pm 20\%$ between the different columns. Determine the average temperature, T_{ars} , of the MO resistors. If the result is higher than 60 °C this temperature shall be used as preheating temperature, otherwise 60 °C shall be used.

Annex J (normative)

Determination of the average temperature of a multi-unit high-voltage arrester

The following approach shall be chosen if the average temperature T_{ar} of a multi-unit high-voltage arrester shall be determined by temperature measurements.

Minimum required number of measuring points: in the units next to a grading ring (below and above) at least two, in all other units at least one.

For the averaging, each temperature measurement point represents the following fraction of the rated voltage

$$U_{r,repr} = U_{r,unit} / n_{mp}$$

with

$U_{r,repr}$ = representative rated voltage of the unit

$U_{r,unit}$ = rated voltage of the unit

n_{mp} = number of measuring points per unit

The measured temperature above ambient of each measuring point is then weighted with the ratio of its representative rated voltage over the complete arrester's rated voltage:

$$U_{r,repr} / U_{r,complete}$$

The example given in Figure J.1 shows a three unit arrester where all units have the same rated voltage:

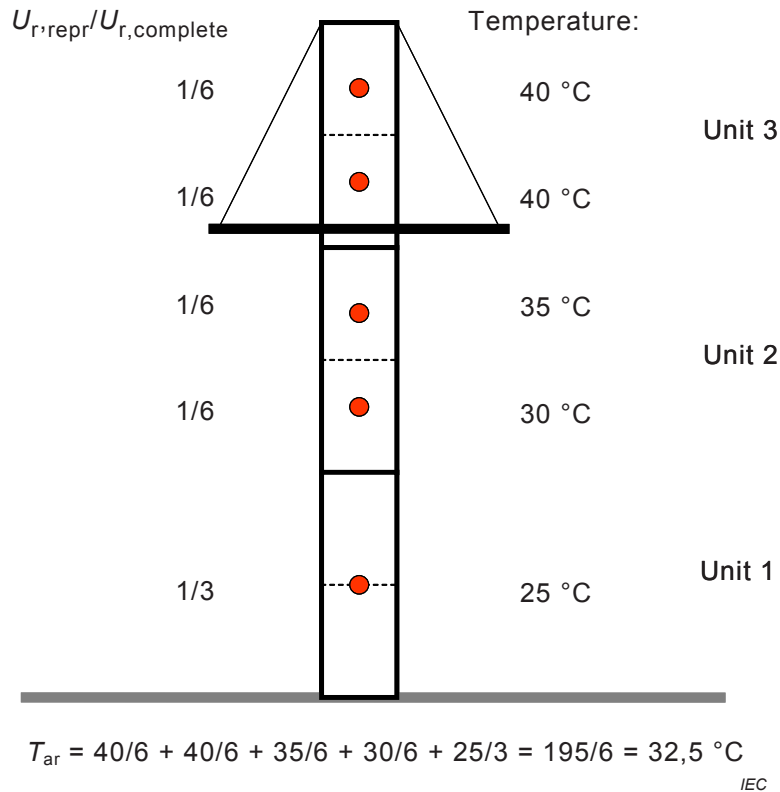

Figure J.1 – Determination of average temperature in case of arrester units of same rated voltages

The example given in Figure J.2 shows the same situation in case that all units have different rated voltages:

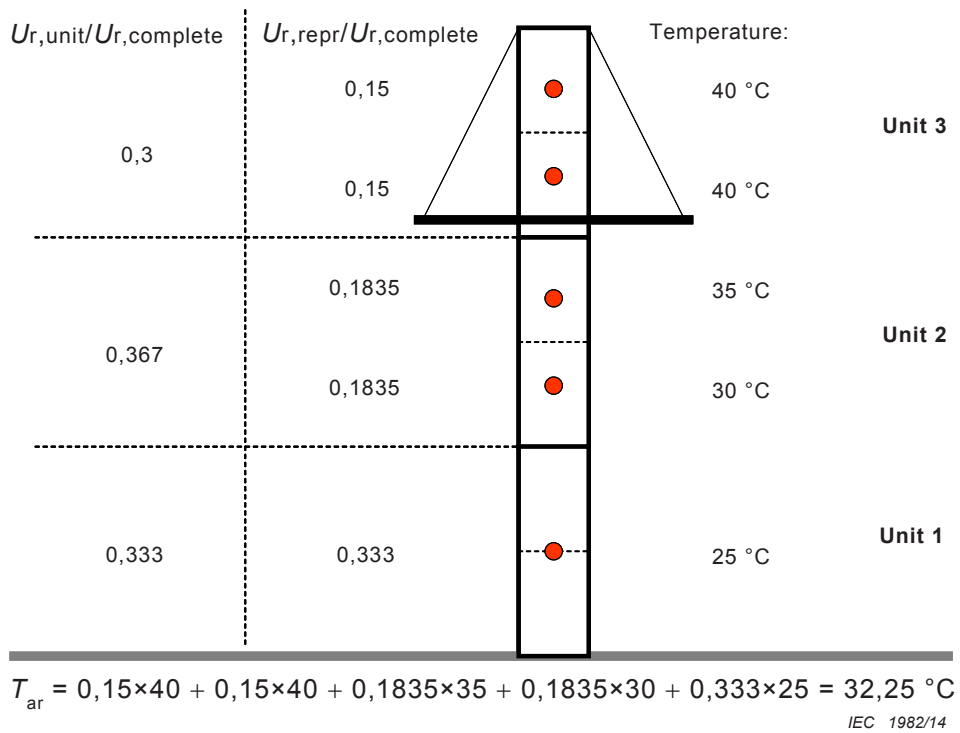

Figure J.2 – Determination of average temperature in case of arrester units of different rated voltages

Annex K (informative)

Example calculation of test parameters for the operating duty test (8.7) according to the requirements of 7.3

Technical data of arrester

- Rated voltage: $U_{r, \text{arrester}} = 198 \text{ kV}$
- Minimum reference voltage: $U_{\text{refmin, arrester}} = 194 \text{ kV}$
- Continuous operating voltage: $U_{c, \text{arrester}} = 154 \text{ kV}$
- Lightning impulse protection level U_{pl} equal to maximum residual voltage at
- nominal discharge current $I_n = 10 \text{ kA}$: $U_{\text{pl, arrester}} = 475 \text{ kV}$
- Minimum residual voltage at nominal discharge current $I_n = 10 \text{ kA}$: $U_{\text{resmin, arrester}} = 460 \text{ kV}$
- Rated thermal energy: $W_{\text{th}} = 10 \text{ kJ/kV}$

Technical data of metal oxide (MO) resistors

- Range of residual voltage at 10 kA, 8/20 μs : 9,0 kV to 10,0 kV

Test parameters of arrester section

- Test sample consisting of two metal oxide resistors in series ($N_{\text{sample}} = 2$)
- Calculation of sample's rated voltage $U_{r, \text{corr, sample}}$ acc. to 7.3 a)
 - to fulfill the requirement of minimum volume, MO resistors with the maximum residual voltage of 10 kV are selected for the minimum residual voltage of the arrester:
 - $N_{\text{arrester}} = U_{\text{resmin, arrester}} / U_{\text{resmax, MO resistor}} = 460 \text{ kV} / 10 \text{ kV} = 46$
 - $n = N_{\text{arrester}} / N_{\text{sample}} = 46 / 2 = 23$
 - $U_{r, \text{sample}} = U_{r, \text{arrester}} / n = 198 \text{ kV} / 23 = 8,61 \text{ kV}$
 - Correction acc. to 7.3 b)
 - $k = U_{\text{refmin, arrester}} / U_{r, \text{arrester}} = 194 \text{ kV} / 198 \text{ kV} = 0,98$
 - test sample's reference voltage measured (for example): $U_{\text{ref, sample}} = 8,70 \text{ kV}$
 - $k \times U_{r, \text{arrester}} / n = 0,98 \times 198 \text{ kV} / 23 = 8,44 \text{ kV}$
 - $U_{\text{ref, sample}} > k \times U_{r, \text{arrester}} / n$
 - Correction: $n_{\text{corr}} = U_{\text{refmin, arrester}} / U_{\text{ref, sample}} = 194 \text{ kV} / 8,70 \text{ kV} = 22,3$
 - $U_{r, \text{corr, sample}} = U_{r, \text{arrester}} / n_{\text{corr}} = 198 \text{ kV} / 22,3 = 8,88 \text{ kV}$
- Calculation of sample's continuous operating voltage $U_{c, \text{sample}}$ acc. to 7.3 e)
 - $U_{c, \text{sample}} = (U_{c, \text{arrester}} / U_{r, \text{arrester}}) \times U_{r, \text{corr, sample}} = (154 \text{ kV} / 198 \text{ kV}) \times 8,88 \text{ kV} = 6,91 \text{ kV}$
- Calculation of required thermal energy injection
 - $W_{\text{th, sample}} = W_{\text{th}} \times U_{r, \text{corr, sample}} = 10 \text{ kJ/kV} \times 8,88 \text{ kV} = 88,8 \text{ kJ}$

Annex L (informative)

Comparison of the old energy classification system based on line discharge classes and the new classification system based on thermal energy ratings for operating duty tests and repetitive charge transfer ratings for repetitive single event energies

To demonstrate energy handling capability of surge arresters “Long duration current impulse withstand tests” and “Switching impulse operating duty tests” have to be carried out according to IEC 60099-4 Ed. 2.2. The “Long duration current impulse withstand test” has to be performed on single metal oxide resistors and, therefore, is a MO resistor related test. The “Switching impulse operating duty test” has to be performed on prorated sections – representing electrical and thermal behaviour of the complete arrester – in order to verify thermal recovery after energy dissipation according to the particular line discharge class. It is, therefore, related to the MO resistor characteristic and the overall design of the complete arrester.

The parameters for the old line discharge test have been specified with the intention to obtain increasing energies with increasing discharge class for arresters having a given ratio of switching impulse residual voltage to rated voltage. However, the energy dissipated in the test samples during test is strongly dependent on the actual residual voltage of the tested MO resistors and in particular for the higher line discharge classes 3 to 5 as shown by Figure L.1. For estimating the discharge energy thus the minimum residual voltage of the arrester is important and not the maximum specified. By increasing the protection level of an arrester by e.g. adding more MO resistors in series the discharge test energy can be decreased and a higher line discharge class can be claimed for the same type of resistors. It is thus difficult to compare actual energy handling capability of an arrester by only the line discharge rating if the actual test energy is not also published.

For reference, Table 4, Table 5 and Figure E.1 from IEC 60099-4 Ed. 2.2, which provide relevant information for this discussion, are reproduced here as Table L.1, Table L.2 and Figure L.1, respectively.

Table L.1 – Peak currents for switching impulse residual voltage test
(Reproduction of Table 4 of IEC 60099-4:2009)

Arrester classification	Peak currents A
20 000 A, line discharge Classes 4 and 5	500 and 2 000
10 000 A, line discharge Class 3	250 and 1 000
10 000 A, line discharge Classes 1 and 2	125 and 500

**Table L.2 – Parameters for the line discharge test
on 20 000 A and 10 000 A arresters**
(Reproduction of Table 5 of IEC 60099-4:2009)

Arrester classification	Line discharge class	Surge impedance of the line Z Ω	Virtual duration of peak T μs	Charging voltage U_L kV d.c.
10 000 A	1	$4,9 U_r$	2 000	$3,2 U_r$
10 000 A	2	$2,4 U_r$	2 000	$3,2 U_r$
10 000 A	3	$1,3 U_r$	2 400	$2,8 U_r$
20 000 A	4	$0,8 U_r$	2 800	$2,6 U_r$
20 000 A	5	$0,5 U_r$	3 200	$2,4 U_r$

U_r is the rated voltage of the test sample in kilovolts r.m.s.

NOTE Classes 1 to 5 correspond to increasing discharge requirements. The selection of the appropriate discharge class is based on system requirements and is dealt with in Annex E.

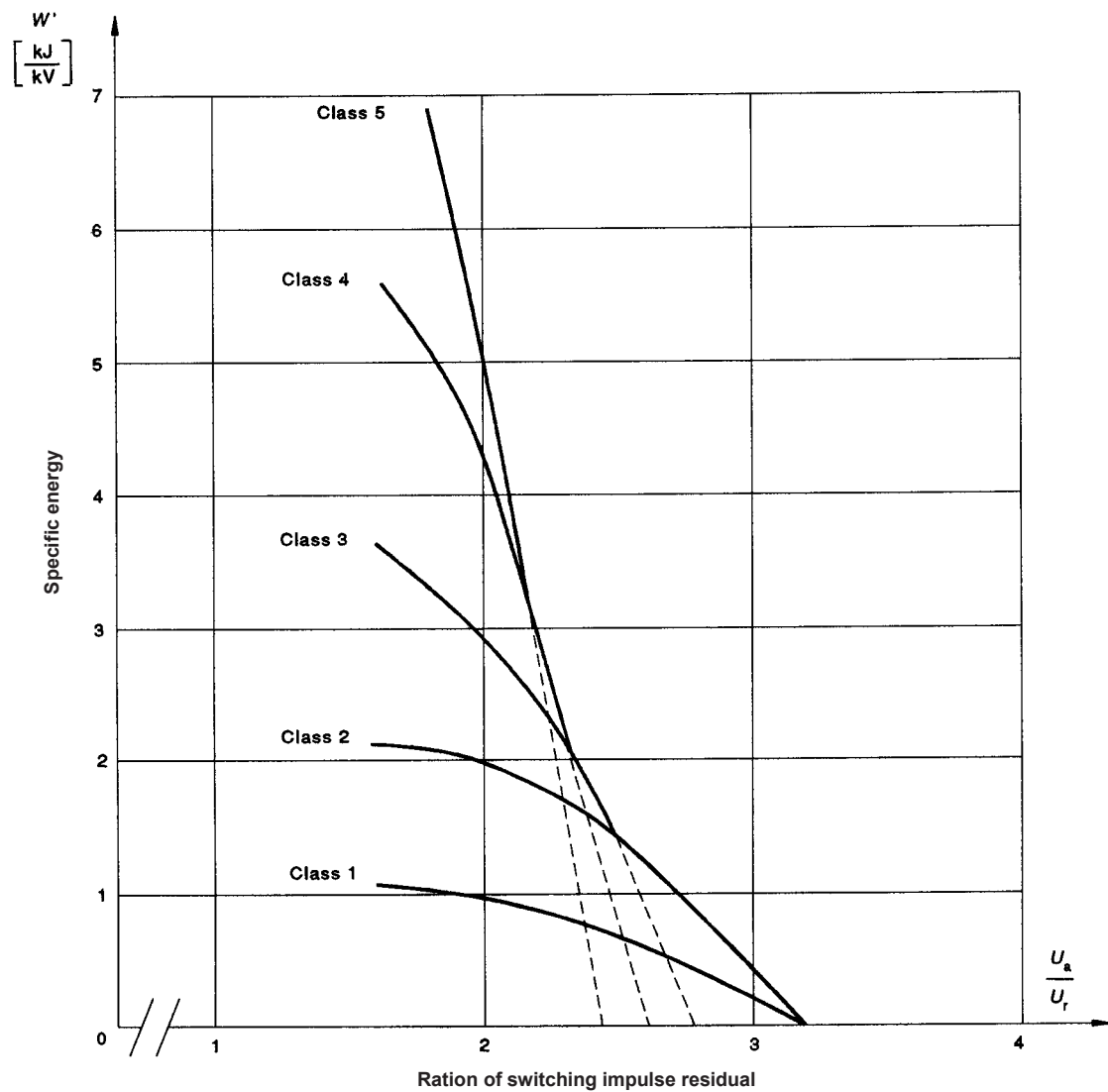

IEC 1983/14

Parameter: line discharge class.

Figure L.1 – Specific energy in kJ per kV rating dependant on the ratio of switching impulse residual voltage (U_a) to the r.m.s. value of the rated voltage U_r of the arrester
(Reproduction of Figure E.1 of IEC 60099-4:2009)

The curves of Figure L.1 are derived from the formula

$$W' = \frac{U_{\text{res}}}{U_r} \left[\frac{U_L}{U_r} - \frac{U_{\text{res}}}{U_r} \right] \times \frac{U_r}{Z} \times T \quad (\text{L.1})$$

where

U_r is the rated voltage (r.m.s. value);

U_L is the charging voltage of the generator;

W' is the specific energy equal to the energy divided by the rated voltage;

U_{res} is the residual voltage at switching impulse current (see Table L.1);

Z is the surge impedance of the line;

T is the virtual duration of the current peak.

In the new system the line discharge classes are replaced by charge ratings to test the repetitive single event energy handling of a MO resistor and by energy ratings to test the thermal recovery of an arrester after energy dissipation.

In general, the following designations are used in this Annex:

U_r rated voltage

LDC line discharge class

U_{pl} lightning impulse protection level

W energy = $U_{\text{res}} \cdot (U_L - U_{\text{res}}) \cdot 1/Z \cdot T$ (required minimum test energy)

$U_{\text{resmax}}(I)$ maximum residual voltage at a given switching impulse current as per Table L.1

$U_{\text{resmin}}(I)$ minimum residual voltage at a given switching impulse current I as per Table L.1

$U_L; Z; T$ test parameters according to Table L.2

Table L.3 provides a comparison of the old (IEC 60099-4:2009) and the new (IEC 60099-4, current edition) systems for typical system configurations.

NOTE The information given here is not normative, but is given for general illustrative purposes to compare the old and new systems

The discharge energies in the different line discharge classes are given under the following assumptions:

a) Maximum switching surge protection level $U_{\text{resmax}}(I_{\text{max}}) = 2,0 \times U_r$ at maximum currents in Table L.1.

b) Minimum switching surge protection level $U_{\text{resmin}}(I_{\text{max}}) = 1,9 \times U_r$ at maximum currents in Table L.1.

c) Minimum residual voltage $U_{\text{resmin}}(I_{\text{min}}) = 1,8 \times U_r$ at minimum currents in Table L.1.

Then, five examples are given to demonstrate in more detail the relation between the old line discharge classes and the new classification in terms of thermal energy rating, repetitive charge transfer rating and protection level.

Table L.3 – Comparison of the classification system according to IEC 60099-4:2009 (Ed.2.2) and to IEC 60099-4:2014 (Ed.3.0)

Old LDC	Required minimum test energy ^a kJ/kV	Corresponding new thermal energy rating as per 8.7.3 W_{th} kJ/kV	Estimated current at old LD test ^b A	Charge calculated with the same current and duration as for old LDC to give the required minimum energy C	Corresponding new repetitive charge transfer rating as per 8.5.4 Q_{rs} C	Repetitive charge transfer test value (= $1,1 \times Q_{rs}$) C
1	1,0	2	277	0,56	0,5	0,55
2	2,1	4	538	1,10	1	1,10
3	3,3	7	721	1,78	1,6	1,76
4	5,0	10	962	2,75	2,4	2,64
5	6,9	14	1118	3,75	3,6	3,96

a Calculated with $U_{resmin}(I_{min}) = 1,8 \times U_r$ (see Figure L.1).
b Estimated from LD parameters and b) and c) above.

MO resistors with the highest acceptable residual voltage in the design shall be tested. This may reduce the selected rated charge additionally.

Special Examples:

Example 1:

$$\begin{aligned}
 U_r &= 120 \text{ kV} \\
 \text{LDC} &= 2 \\
 I_n &= 10 \text{ kA} \\
 U_{pl} &= 300 \text{ kV} \\
 U_{resmax}(500 \text{ A}) &= 233 \text{ kV} (1,94 \times U_r) \\
 U_{resmin}(500 \text{ A}) &= 0,95 \times U_{resmax}(500 \text{ A}) = 221 \text{ kV} \\
 U_{resmax}(125 \text{ A}) &= 220 \text{ kV} \\
 U_{resmin}(125 \text{ A}) &= 0,95 \times U_{resmax}(125 \text{ A}) = 209 \text{ kV}
 \end{aligned}$$

Calculated:

- Minimum test energy: $W = 254 \text{ kJ} \Rightarrow W/U_r = 2,12 \text{ kJ/kV}$
- To be applied two times in the switching impulse operating duty test $\Rightarrow 4,24 \text{ kJ/kV}$
- Thermal energy rating (*new*) according to 8.7.3: $W_{th} = 4 \text{ kJ/kV}$
- Current at LD: $I = 558 \text{ A}$
- Charge calculated with the same current and duration as for LD to give the required minimum energy: $Q = 1,14 \text{ C}$
- Repetitive charge transfer rating (*new*) according to 8.5.4: $Q_{rs} = 1,2 \text{ C}$ (i.e. test value = $1,32 \text{ C}$)

Example 2:

$$\begin{aligned}
 U_r &= 120 \text{ kV} \\
 \text{LDC} &= 3 \\
 I_n &= 10 \text{ kA} \\
 U_{pl} &= 360 \text{ kV} \\
 U_{resmax}(1\,000 \text{ A}) &= 289 \text{ kV} (2,41 \times U_r)
 \end{aligned}$$

$$\begin{aligned}
 U_{\text{resmin}} (1\,000\text{ A}) &= 0,95 \times U_{\text{resmax}} (1\,000\text{ A}) &= 274,6\text{ kV} \\
 U_{\text{resmax}} (250\text{ A}) &= 270\text{ kV} \\
 U_{\text{resmin}} (250\text{ A}) &= 0,95 \times U_{\text{resmax}} (250\text{ A}) &= 256,5\text{ kV}
 \end{aligned}$$

Calculated:

- Minimum test energy: $W = 313,7\text{ kJ} \Rightarrow W/U_r = 2,61\text{ kJ/kV}$
- To be applied two times in the switching impulse operating duty test $\Rightarrow 5,22\text{ kJ/kV}$
- Thermal energy rating (*new*) according to 8.7.3: $W_{\text{th}} = 5\text{ kJ/kV}$
- Current at LD: $I = 475\text{ A}$
- Charge calculated with the same current and duration as for LD to give the required minimum energy: $Q = 1,2\text{ C}$
- Repetitive charge transfer rating (*new*) according to 8.5.4: $Q_{\text{rs}} = 1,2\text{ C}$ (i.e. test value = 1,32 C)

Examples 1 and 2 show that arresters with different line discharge classes (2 and 3) will result in the same repetitive charge transfer rating and nearly the same thermal energy rating when changing the switching impulse protection level accordingly. Also note that in Example 2 the protection level of the arrester is significantly higher than the typical value used in Table L.1, which reduces the discharge energy down to a typical value for LDC 2.

Example 3:

$$\begin{aligned}
 U_r &= 120\text{ kV} \\
 \text{LDC} &= 3 \\
 I_n &= 10\text{ kA} \\
 U_{\text{pl}} &= 300\text{ kV} \\
 U_{\text{resmax}} (1\,000\text{ A}) &= 241\text{ kV} (2,01 \cdot U_r) \\
 U_{\text{resmin}} (1\,000\text{ A}) &= 0,95 \times U_{\text{resmax}} (1\,000\text{ A}) &= 229,0\text{ kV} \\
 U_{\text{resmax}} (250\text{ A}) &= 225\text{ kV} \\
 U_{\text{resmin}} (250\text{ A}) &= 0,95 \times U_{\text{resmax}} (250\text{ A}) &= 213,8\text{ kV}
 \end{aligned}$$

Calculated:

- Minimum test energy: $W = 402,0\text{ kJ} \Rightarrow W/U_r = 3,35\text{ kJ/kV}$
- To be applied two times in the switching impulse operating duty test $\Rightarrow 6,7\text{ kJ/kV}$
- Thermal energy rating (*new*) according to 8.7.3: $W_{\text{th}} = 7\text{ kJ/kV}$
- Current at LD: $I = 722\text{ A}$
- Charge calculated with the same current and duration as for LD to give the required minimum energy: $Q = 1,8\text{ C}$
- Repetitive charge transfer rating (*new*) according to 8.5.4: $Q_{\text{rs}} = 1,6\text{ C}$ or $Q_{\text{rs}} = 2,0\text{ C}$ (i.e. test value = 2,2 C)

Example 3, in comparison to example 1, shows that a higher line discharge class leads to higher requirements on repetitive charge transfer rating and thermal energy rating when the switching impulse protection level is unchanged.

Example 4:

$$\begin{aligned}
 U_r &= 420\text{ kV} \\
 \text{LDC} &= 5 \\
 I_n &= 20\text{ kA}
 \end{aligned}$$

$$\begin{aligned}
 U_{pl} &= 1\,100 \text{ kV} \\
 U_{resmax} (2\,000 \text{ A}) &= 867 \text{ kV} (2,06 \times U_r) \\
 U_{resmin} (2\,000 \text{ A}) &= 0,95 \times U_{resmax} (2\,000\text{A}) = 823,7 \text{ kV} \\
 U_{resmax} (500 \text{ A}) &= 810 \text{ kV} \\
 U_{resmin} (500 \text{ A}) &= 0,95 \times U_{resmax} (500\text{A}) = 769,5 \text{ kV}
 \end{aligned}$$

Calculated:

Minimum test energy: $W = 2797 \text{ kJ} \Rightarrow W/U_r = 6,66 \text{ kJ/kV}$

To be applied two times in the switching impulse operating duty test $\Rightarrow 13,32 \text{ kJ/kV}$

Thermal energy rating (*new*) according to 8.7.3: $W_{th} = 13 \text{ kJ/kV}$

Current at LD: $I = 1042 \text{ A}$

Charge calculated with the same current and duration as for LD to give the required minimum energy: $Q = 3,54 \text{ C}$

Repetitive charge transfer rating (*new*) according to 8.5.4: $Q_{rs} = 3,6 \text{ C}$ (i.e. test value = 3,96 C)

Example 5:

$$\begin{aligned}
 U_r &= 420 \text{ kV} \\
 LDC &= 5 \\
 I_n &= 20 \text{ kA} \\
 U_{pl} &= 1\,000 \text{ kV} \\
 U_{resmax} (2\,000 \text{ A}) &= 788 \text{ kV} (1,88 \times U_r) \\
 U_{resmin} (2\,000 \text{ A}) &= 0,95 \cdot U_{resmax} (2\,000 \text{ A}) = 748,6 \text{ kV} \\
 U_{resmax} (500 \text{ A}) &= 750 \text{ kV} \\
 U_{resmin} (500 \text{ A}) &= 0,95 \times U_{resmax} (500 \text{ A}) = 712,5 \text{ kV}
 \end{aligned}$$

Calculated:

- Minimum test energy: $W = 3208 \text{ kJ} \Rightarrow W/U_r = 7,64 \text{ kJ/kV}$
- to be applied two times in the switching impulse operating duty test $\Rightarrow 15,28 \text{ kJ/kV}$
- Thermal energy rating (*new*) according to 8.7.3: $W_{th} = 16 \text{ kJ/kV}$
- Current at LD: $I = 1314 \text{ A}$
- Charge calculated with the same current and duration as for LD to give the required minimum energy: $Q = 4,38 \text{ C}$
- Repetitive charge transfer rating (*new*) according to 8.5.4: $Q_{rs} = 4,4 \text{ C}$ (i.e. test value = 4,84 C)

As shown in examples 4 and 5 the same line discharge class leads to different thermal energy ratings and repetitive charge transfer ratings depending on the switching impulse protection level. Also note that the protection level in Example 4 is relatively high for a normal class 5 arrester.

Bibliography

IEC 60068-2-17, *Basic environmental testing procedures – Part 2: Tests – Test Q: Sealing*

IEC 60099-1, *Surge arresters – Part 1: Non-linear resistor type gapped arresters for a.c. systems*

IEC 60099-5:2013, *Surge arresters – Part 5: Selection and application recommendations*

IEC 60721-3-2, *Classification of environmental conditions – Part 3: Classification of groups of environmental parameters and their severities – Section 2: Transportation*

IEC TS 60815-3, *Selection and dimensioning of high voltage insulators intended for use in polluted conditions – Part 3: Polymer insulators for a.c. systems*

IEC 62271-202:2006, *High-voltage switchgear and controlgear – Part 202: High-voltage/low voltage prefabricated substation*

ISO 3274, *Geometrical Product Specifications (GPS) – Surface texture: Profile method – Nominal characteristics of contact (stylus) instruments*

IEEE C62.11:1999, *Standard for Metal-Oxide Surge Arresters for Alternating Current Power Circuits (>1 kV)*

British Standards Institution (BSI)

BSI is the national body responsible for preparing British Standards and other standards-related publications, information and services.

BSI is incorporated by Royal Charter. British Standards and other standardization products are published by BSI Standards Limited.

About us

We bring together business, industry, government, consumers, innovators and others to shape their combined experience and expertise into standards-based solutions.

The knowledge embodied in our standards has been carefully assembled in a dependable format and refined through our open consultation process. Organizations of all sizes and across all sectors choose standards to help them achieve their goals.

Information on standards

We can provide you with the knowledge that your organization needs to succeed. Find out more about British Standards by visiting our website at bsigroup.com/standards or contacting our Customer Services team or Knowledge Centre.

Buying standards

You can buy and download PDF versions of BSI publications, including British and adopted European and international standards, through our website at bsigroup.com/shop, where hard copies can also be purchased.

If you need international and foreign standards from other Standards Development Organizations, hard copies can be ordered from our Customer Services team.

Subscriptions

Our range of subscription services are designed to make using standards easier for you. For further information on our subscription products go to bsigroup.com/subscriptions.

With **British Standards Online (BSOL)** you'll have instant access to over 55,000 British and adopted European and international standards from your desktop. It's available 24/7 and is refreshed daily so you'll always be up to date.

You can keep in touch with standards developments and receive substantial discounts on the purchase price of standards, both in single copy and subscription format, by becoming a **BSI Subscribing Member**.

PLUS is an updating service exclusive to BSI Subscribing Members. You will automatically receive the latest hard copy of your standards when they're revised or replaced.

To find out more about becoming a BSI Subscribing Member and the benefits of membership, please visit bsigroup.com/shop.

With a **Multi-User Network Licence (MUNL)** you are able to host standards publications on your intranet. Licences can cover as few or as many users as you wish. With updates supplied as soon as they're available, you can be sure your documentation is current. For further information, email bsmusales@bsigroup.com.

BSI Group Headquarters

389 Chiswick High Road London W4 4AL UK

Revisions

Our British Standards and other publications are updated by amendment or revision.

We continually improve the quality of our products and services to benefit your business. If you find an inaccuracy or ambiguity within a British Standard or other BSI publication please inform the Knowledge Centre.

Copyright

All the data, software and documentation set out in all British Standards and other BSI publications are the property of and copyrighted by BSI, or some person or entity that owns copyright in the information used (such as the international standardization bodies) and has formally licensed such information to BSI for commercial publication and use. Except as permitted under the Copyright, Designs and Patents Act 1988 no extract may be reproduced, stored in a retrieval system or transmitted in any form or by any means – electronic, photocopying, recording or otherwise – without prior written permission from BSI. Details and advice can be obtained from the Copyright & Licensing Department.

Useful Contacts:

Customer Services

Tel: +44 845 086 9001

Email (orders): orders@bsigroup.com

Email (enquiries): cservices@bsigroup.com

Subscriptions

Tel: +44 845 086 9001

Email: subscriptions@bsigroup.com

Knowledge Centre

Tel: +44 20 8996 7004

Email: knowledgecentre@bsigroup.com

Copyright & Licensing

Tel: +44 20 8996 7070

Email: copyright@bsigroup.com