

BS EN 60079-35-2:2012



BSI Standards Publication

Explosive atmospheres

Part 35-2: Caplights for use in mines
susceptible to firedamp — Performance
and other safety-related matters
(IEC 60079-35-2:2011)

bsi.

...making excellence a habit.™

National foreword

This British Standard is the UK implementation of EN 60079-35-2:2012. It is identical to IEC 60079-35-2:2011. It supersedes BS EN 62013-2:2006, which is withdrawn.

The UK participation in its preparation was entrusted to Technical Committee EXL/31, Equipment for explosive atmospheres.

A list of organizations represented on this committee can be obtained on request to its secretary.

This publication does not purport to include all the necessary provisions of a contract. Users are responsible for its correct application.

© The British Standards Institution 2012

Published by BSI Standards Limited 2012

ISBN 978 0 580 72294 3

ICS 29.260.20; 73.100.20

Compliance with a British Standard cannot confer immunity from legal obligations.

This British Standard was published under the authority of the Standards Policy and Strategy Committee on 30 September 2012.

Amendments issued since publication

| Amd. No. | Date | Text affected |
|-----------------|-------------|----------------------|
|-----------------|-------------|----------------------|

English version

**Explosive atmospheres -
Part 35-2: Caplights for use in mines susceptible to firedamp -
Performance and other safety-related matters
(IEC 60079-35-2:2011)**

Atmosphères explosives -
Partie 35-2: Lampes chapeaux utilisables
dans les mines grisouteuses -
Performances et autres sujets relatifs à la
sécurité
(CEI 60079-35-2:2011)

Explosionsfähige Atmosphäre -
Teil 35-2: Kopfleuchten für die
Verwendung in schlagwettergefährdeten
Grubenbauen -
Gebrauchstauglichkeit und andere
sicherheitsrelevante Themen
(IEC 60079-35-2:2011)

This European Standard was approved by CENELEC on 2012-01-11. CENELEC members are bound to comply with the CEN/CENELEC Internal Regulations which stipulate the conditions for giving this European Standard the status of a national standard without any alteration.

Up-to-date lists and bibliographical references concerning such national standards may be obtained on application to the CEN-CENELEC Management Centre or to any CENELEC member.

This European Standard exists in three official versions (English, French, German). A version in any other language made by translation under the responsibility of a CENELEC member into its own language and notified to the CEN-CENELEC Management Centre has the same status as the official versions.

CENELEC members are the national electrotechnical committees of Austria, Belgium, Bulgaria, Croatia, Cyprus, the Czech Republic, Denmark, Estonia, Finland, Former Yugoslav Republic of Macedonia, France, Germany, Greece, Hungary, Iceland, Ireland, Italy, Latvia, Lithuania, Luxembourg, Malta, the Netherlands, Norway, Poland, Portugal, Romania, Slovakia, Slovenia, Spain, Sweden, Switzerland, Turkey and the United Kingdom.

CENELEC

European Committee for Electrotechnical Standardization
Comité Européen de Normalisation Electrotechnique
Europäisches Komitee für Elektrotechnische Normung

Management Centre: Avenue Marnix 17, B - 1000 Brussels

Foreword

The text of document 31/955/FDIS, future edition 1 of IEC 60079-35-2, prepared by IEC/TC 31 "Equipment for explosive atmospheres" was submitted to the IEC-CENELEC parallel vote and approved by CENELEC as EN 60079-35-2:2012.

The following dates are fixed:

- latest date by which the document has to be implemented at national level by publication of an identical national standard or by endorsement (dop) 2013-02-10
- latest date by which the national standards conflicting with the document have to be withdrawn (dow) 2015-01-11

This document supersedes EN 62013-2:2006.

The general revision and updating of EN 62013-2:2006 has been necessitated by the advent of new technologies related to caplight design, in particular those related light-emitting diode (LED) light sources. It is intended that there should be a stronger link between Part 1 (Construction) and Part 2 (Performance) of this standard by upgrading the reference in the scope of part 1 from a note to a requirement.

In addition, as this standard is now to become one of the EN 60079 series, changes have been made to bring it more in line with others in the series by cross referencing. This has enabled there to be a reduction in the number and length of clauses in the standard.

Attention is drawn to the possibility that some of the elements of this document may be the subject of patent rights. CENELEC [and/or CEN] shall not be held responsible for identifying any or all such patent rights.

Endorsement notice

The text of the International Standard IEC 60079-35-2:2011 was approved by CENELEC as a European Standard without any modification.

Annex ZA (normative)

Normative references to international publications with their corresponding European publications

The following documents, in whole or in part, are normatively referenced in this document and are indispensable for its application. For dated references, only the edition cited applies. For undated references, the latest edition of the referenced document (including any amendments) applies.

NOTE When an international publication has been modified by common modifications, indicated by (mod), the relevant EN/HD applies.

| <u>Publication</u> | <u>Year</u> | <u>Title</u> | <u>EN/HD</u> | <u>Year</u> |
|--------------------|-------------|--|---------------|-------------|
| IEC 60050-845 | - | International Electrotechnical Vocabulary (IEV) - Chapter 845: Lighting | - | - |
| IEC 60079-35-1 | - | Explosive atmospheres - Part 35-1: Caplights for use in mines susceptible to firedamp - General requirements - Construction and testing in relation to the risk of explosion | EN 60079-35-1 | - |
| IEC 60983 | - | Miniature lamps | EN 60983 | - |
| ISO 80000-1 | - | Quantities and units - Part 1: General | - | - |

CONTENTS

| | | |
|-------|--|----|
| 1 | Scope | 5 |
| 2 | Normative references | 5 |
| 3 | Terms and definitions | 5 |
| 4 | Light output | 5 |
| 4.1 | Light sources | 5 |
| 4.2 | Light source holder | 6 |
| 4.3 | Luminous intensity and illuminance | 6 |
| 4.4 | Auxiliary light source | 6 |
| 4.5 | Focus | 6 |
| 4.6 | Chromaticity | 6 |
| 5 | Reliability | 6 |
| 5.1 | Lamp life | 6 |
| 5.2 | Battery life (charge/discharge cycles) | 7 |
| 5.3 | Caplight useful working period | 7 |
| 5.4 | Durability | 7 |
| 5.4.1 | Fasteners and connectors | 7 |
| 5.4.2 | Resistance to abrasion | 7 |
| 5.4.3 | Operability after mechanical tests | 7 |
| 6 | Ergonomics | 7 |
| 6.1 | Mass | 7 |
| 6.2 | Ease of operation | 8 |
| 6.3 | Maintainability | 8 |
| 6.4 | Headpiece security | 8 |
| 7 | Type tests – Illumination throughout the useful working period | 8 |
| 8 | Instructions | 9 |
| 9 | Marking | 9 |
| | Annex A (informative) Examples of the manufacturer's instructions for routine testing by the user | 10 |
| | Figure A.1 – Schematic drawing of a typical photometric sphere | 11 |
| | Table A.1 – Tabulation of tests | 12 |

EXPLOSIVE ATMOSPHERES –

Part 35–2: Caplights for use in mines susceptible to firedamp – Performance and other safety-related matters

1 Scope

This part of IEC 60079-35 details those performance and other safety features of caplights, including those with a point of connection for another equipment, not covered in IEC 60079-35-1, but which are important for the safety and working conditions of the user. It may also be applied to caplights for use in mines not likely to be endangered by firedamp.

NOTE When this part of the standard is used as a "stand-alone" document for non-gassy mines, any relevant constructional requirements should be the subject of agreement between the supplier and the user and, where possible, be as described in IEC 60079-35-1.

2 Normative references

The following referenced documents are indispensable for the application of this document. For dated references, only the edition cited applies. For undated references, the latest edition of the referenced document (including any amendments) applies.

IEC 60050-845, *International Electrotechnical Vocabulary (IEV) – Chapter 845: Lighting*

IEC 60983, *Miniature lamps*

IEC 60079-35-1, *Explosive atmospheres – Part 35-1: Caplights for use in mines susceptible to firedamp – General requirements – Construction and testing in relation to the risk of explosion*¹

ISO 80000-1, *Quantities and units – Part 1: General*

3 Terms and definitions

For the purposes of this document, the definitions of ISO 80000-1 and IEC 60050(845) and the following apply:

3.1

useful working period

period in hours defined by the manufacturer, taking into account the current drawn by the main light source and if appropriate, the average current drawn by any accessories during that period, during which the main light source of the caplight may be continuously used and comply with the minimum luminous intensity requirements of this standard

4 Light output

4.1 Light sources

4.1.1 Every headpiece shall have a minimum of two light sources, at least one of which shall be the main source and meet the requirements of this part of IEC 60079-35. Alternatively a

¹ To be published

single light source may be used provided it is a non-filament type and it meets the lamp life defined in 5.1.

4.1.2 Where a caplight is fitted with two light sources, each of which is capable of being the main source, the manufacturer shall designate which of these shall be the main source and which the auxiliary source; otherwise, both sources shall meet the requirements for the main source.

4.1.3 Filament lamps for main and auxiliary sources shall comply with IEC 60983. Where the relevant data sheet is not given in IEC 60983, an equivalent shall be provided by the caplight manufacturer.

4.2 Light source holder

The holder for the main light source shall be capable of locating and retaining it securely in a focused position with respect to the reflector profile in accordance with 4.5.

4.3 Luminous intensity and illuminance

The main beam of light from a headpiece mounted on its intended helmet, in its normal operating orientation, shall point 10 degrees \pm 5 degrees down from the horizontal.

NOTE A statement from the caplight manufacturer stating compliance with this requirement is acceptable and need not be verified if certification is sought.

At the end of the useful working period, the luminous intensity from the main light source in a fully assembled headpiece, mounted on its intended helmet in its normal operating orientation, shall extend a cone with a minimum of 1 cd (1 lux at 1m). This cone shall not be less than 30 degrees up from the main beam of light, 60 degrees down from the main beam of light and 60 degrees to each side. This may be calculated from manufacturers' data or tested in accordance with Clause 7. The maximum illumination shall not be less than 1 500 cd (1 500 lux at 1 m).

4.4 Auxiliary light source

The auxiliary light source is primarily intended for emergency use if the main source fails and is exempt from the type tests in Clause 7.

4.5 Focus

The main light source shall be focused, or capable of being focused, so that the light pattern is not impaired by distortion.

4.6 Chromaticity

For non-filament light sources, the colour correlated temperature (CCT) shall be greater than 5 000 K and the colour rendering index (CRI) shall be greater than 70, unless alternative values are specified by the caplight manufacturer and included in the user instructions.

NOTE The values of CCT and CRI supplied by the caplight manufacturer need not be verified if certification is sought.

5 Reliability

5.1 Lamp life

The light source life of caplights fitted with two filament light sources shall comply with the requirements of *Lamps for miners' caplights* in IEC 60983. If the lamp manufacturer provides a data sheet showing such test results, it may be accepted without further testing. The

minimum life shall be not less than 200 h for the main source and 50 h for the auxiliary source.

The light source life of caplights fitted with two non-filament light sources shall be not less than 200 h for the main source and 50 h for the auxiliary source, when tested at the maximum operating ambient temperature and nominal battery voltage.

For caplights with two light sources, after 200 hours the luminous intensity of the main light source shall meet the requirements of 4.3.

The life of non-filament type single light sources shall not be less than 5 000 h when determined either by test of the entire caplight headpiece or by using manufacturer's life data, junction temperature, maximum operating ambient temperature, nominal battery voltage and appropriate calculations based on the entire caplight headpiece. The resultant luminous intensity after 5 000 hours source shall meet the requirements of 4.3.

5.2 Battery life (charge/discharge cycles)

It is not possible to specify a cyclic life for the battery due to the multiplicity of battery types, charging regimes and conditions of use.

The manufacturer shall prepare instructions to the user on the recharge time and routine checks which are necessary to ensure that the battery is capable of performing its intended duties during the actual working period. See Clause 8 and Annex A.

NOTE The choice of battery charging equipment will depend on the time available between successive actual working periods. When the recharge time is insufficient to fully recharge the battery, the manufacturer may need to advise the user to provide additional caplights.

5.3 Caplight useful working period

The manufacturer shall declare the useful working period of the caplight when new, taking into account the current drawn by the main light source and, if appropriate, the average current drawn by any accessories during that period. The test requirements are given in Clause 7.

5.4 Durability

5.4.1 Fasteners and connectors

Fasteners and connectors shall be designed so that they are not likely to loosen in normal use.

5.4.2 Resistance to abrasion

The caplight shall be constructed from materials which are resistant to abrasion in normal use.

5.4.3 Operability after mechanical tests

Following completion of the Drop tests in IEC 60079-35-1, at least one light source shall still be operable and there shall be no leakage of electrolyte.

6 Ergonomics

6.1 Mass

Unless otherwise agreed between the manufacturer and the user, the mass of the battery and container shall not exceed 2 750 g and the total mass of the complete caplight assembly shall not exceed 3 250 g.

Unless otherwise agreed between the manufacturer and the user, the mass of headpiece only caplights (caplights with an integral battery) shall not exceed 250 g. The recommended maximum mass of the headpiece only caplight is 185 g.

6.2 Ease of operation

The switch shall be easily accessible to the wearer with the caplight in the position normally worn. The switch shall be positive in action.

NOTE The switch should be operable while wearing protective gloves.

6.3 Maintainability

The caplight shall be constructed in such a manner that user replaceable parts are easily accessible after operation or removal of any special fasteners.

If necessitated by the battery design, means shall be provided for initial filling, subsequent topping up and changing of electrolyte.

6.4 Headpiece security

For caplights contained wholly on the helmet a tether that can be readily fastened to the caplight and the torso shall be provided.

NOTE This tether should be durable, light and strong and also be designed to minimise the risk of the tether being caught on mining infrastructure and equipment.

Where headpiece only caplights are intended for use on helmets that have restraints (chin straps) this requirement does not apply.

7 Type tests – Illumination throughout the useful working period

The following test shall be carried out in a darkened room or enclosure having little or no ambient airflow and where any reflected light will not influence the results, at a temperature of (23 ± 2) °C.

Ensure that the caplight has a fully charged battery.

NOTE 1 It may be necessary to cycle the battery several times to achieve full capacity.

Switch on the main light source and, if appropriate, any additional device to simulate the manufacturer's declared total current drain.

Allow the caplight to operate for the useful working period.

Record the battery voltage.

NOTE 2 If an active device which affects the battery output is present, for example a switching regulator, the voltage shall be measured at the input of such a device.

Disconnect the battery and connect the headpiece to a d.c. power source with a residual ripple not greater than 3 mV and capable of maintaining the voltage within $\pm 0,01$ V throughout the test.

Adjust the power supply to the voltage measured at the end of the useful working period. Focus the main light source of the headpiece.

Position the headpiece so that the protective cover is $1\,000\text{ mm} \pm 5\text{ mm}$ away from a calibrated photometric cell.

Move either the headpiece or photocell through the angles specified in 4.3 maintaining the distance specified above. Record the reading on the photocell at 5 ° intervals, or in a specified rectangular grid which gives the same result. The illumination shall meet the requirements of 4.3.

8 Instructions

The manufacturer shall prepare a comprehensive installation, operation, maintenance and repair manual which includes at least the following:

- a) information about the safe use of the caplight;
- b) caplight useful working period;
- c) the minimum illumination at the end of the useful working period at the angles defined in 4.3;
- d) the minimum illumination at the end of the useful working period at the point of maximum illumination.
- e) permitted light source types;
- f) periodic checks by the user to ensure continued safe use, maintenance and lighting performance (see Annex A);
- g) those parts which the user may replace;
- h) list of special tools;
- i) any special instructions required for disposal of batteries and any other applicable components;
- j) the colour correlated temperature (CCT) and the colour rendering index (CRI) of non-filament light sources that do not meet the requirements of 4.6.

9 Marking

Caplights meeting the requirements of this part of IEC 60079-35 shall be marked with the following information:

- a) the name or trademark of the caplight manufacturer;
- b) the manufacturer's type identification;
- c) the number of this standard (IEC 60079-35-2);
- d) on the battery container or cells, a date or code to indicate the month and year of manufacture.

NOTE Where the caplight also meets the requirements of IEC 60079-35-1, it is not necessary to repeat markings required to appear by IEC 60079-35-1 that would otherwise be duplicated by the required markings of IEC 60079-35-2.

Annex A (informative)

Examples of the manufacturer's instructions for routine testing by the user

NOTE Where national or local requirements apply, these should take precedence over the following.

A.1 Preparatory requirements

- a) Select a representative sample of fully charged caplights from the charging racks so that, during a period not exceeding four months, all caplights are tested;
- b) Record the caplight identification or serial numbers;
- c) Visually examine the caplights for defects that would impair performance or safety;
- d) Repair any defects found or remove the caplight from service;
- e) Clean the caplights according to the manufacturer's instructions;
- f) Switch on the main light source for a period of time equal to the length of the working shift including any travelling time within the mine. If the caplight is to be used with an accessory, the additional current will need to be taken into account when carrying out the test.

A.2 Evaluation procedure

a) Example 1

Position the caplight headpiece $1\ 000\ \text{mm} \pm 5\ \text{mm}$ from a suitably calibrated photocell. Find the position of the highest measured value of illumination within a circle of diameter $100\ \text{mm} \pm 2\ \text{mm}$ on a plane parallel to the headpiece protective cover and record the value in lux (E_{max}).

NOTE If the test is not carried out in a darkened room or if the photocell is not shielded against ambient extraneous light, then a measurement should be made of this extraneous light before the test and the value subtracted from the test result.

b) Example 2

Place the caplight headpiece at the window of an integrating sphere having the dimensions shown in Figure A.1.

Measure the luminous flux in lumens.

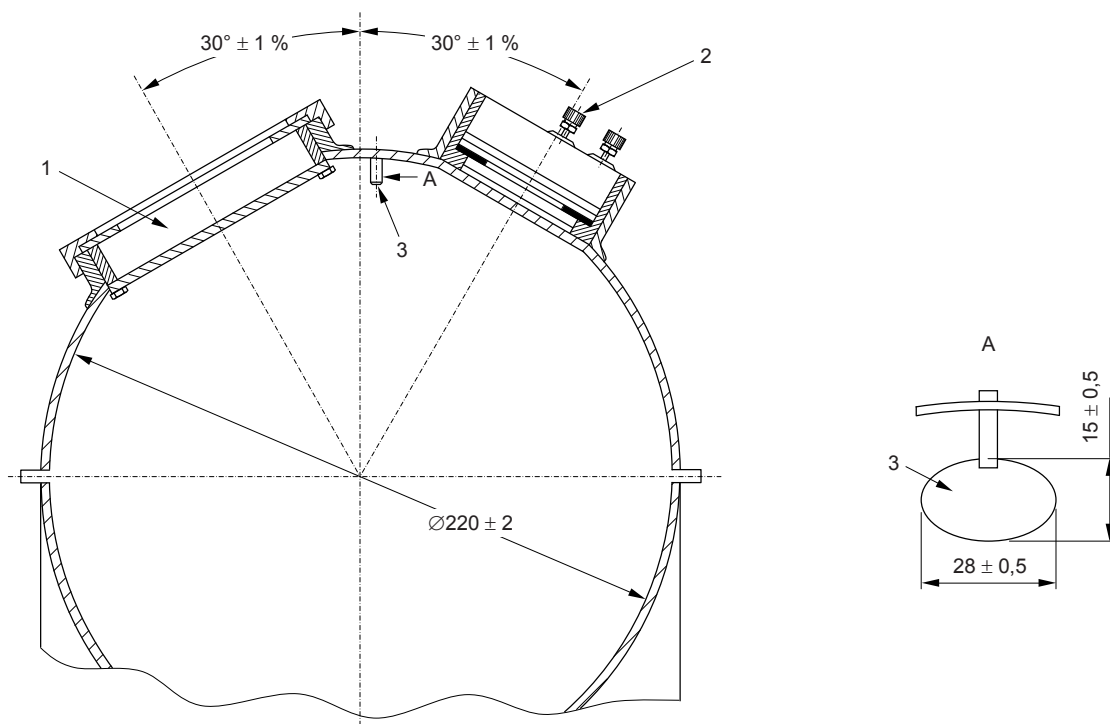

Dimensions in millimetres

Key

- 1 Headpiece aperture
- 2 Photocell
- 3 Baffle
- A Amplification of the baffle (viewed from direction of the arrow)

Figure A.1 – Schematic drawing of a typical photometric sphere

A.3 Pass requirement

a) Example 1

The maximum illumination at 1 m should not be less than 1 500 lx (lux).

b) Example 2

The luminous flux should not be less than 10 lm (lumens).

If a caplight fails to meet the pass requirement, corrective action should be taken before the caplight is put back into service.

A.4 Specimen test report

The test report should include, as a minimum, the following information:

- a) name of mine;
- b) testing department;
- c) name of testing expert;
- d) location of lamp room;

- e) number of caplights in lamp room;
- f) number of caplights checked;
- g) manufacturer and type of caplights;
- h) minimum light output requirement;
- i) number of caplights failing to meet requirement;
- j) date of test;
- k) name and signature of tester.

Table A.1 – Tabulation of tests

| Caplight number | Result | Fault | Corrective action | Remarks |
|-----------------|--------|-------|-------------------|---------|
| | | | | |
| | | | | |
| | | | | |
| | | | | |

British Standards Institution (BSI)

BSI is the national body responsible for preparing British Standards and other standards-related publications, information and services.

BSI is incorporated by Royal Charter. British Standards and other standardization products are published by BSI Standards Limited.

About us

We bring together business, industry, government, consumers, innovators and others to shape their combined experience and expertise into standards-based solutions.

The knowledge embodied in our standards has been carefully assembled in a dependable format and refined through our open consultation process. Organizations of all sizes and across all sectors choose standards to help them achieve their goals.

Information on standards

We can provide you with the knowledge that your organization needs to succeed. Find out more about British Standards by visiting our website at bsigroup.com/standards or contacting our Customer Services team or Knowledge Centre.

Buying standards

You can buy and download PDF versions of BSI publications, including British and adopted European and international standards, through our website at bsigroup.com/shop, where hard copies can also be purchased.

If you need international and foreign standards from other Standards Development Organizations, hard copies can be ordered from our Customer Services team.

Subscriptions

Our range of subscription services are designed to make using standards easier for you. For further information on our subscription products go to bsigroup.com/subscriptions.

With **British Standards Online (BSOL)** you'll have instant access to over 55,000 British and adopted European and international standards from your desktop. It's available 24/7 and is refreshed daily so you'll always be up to date.

You can keep in touch with standards developments and receive substantial discounts on the purchase price of standards, both in single copy and subscription format, by becoming a **BSI Subscribing Member**.

PLUS is an updating service exclusive to BSI Subscribing Members. You will automatically receive the latest hard copy of your standards when they're revised or replaced.

To find out more about becoming a BSI Subscribing Member and the benefits of membership, please visit bsigroup.com/shop.

With a **Multi-User Network Licence (MUNL)** you are able to host standards publications on your intranet. Licences can cover as few or as many users as you wish. With updates supplied as soon as they're available, you can be sure your documentation is current. For further information, email bsmusales@bsigroup.com.

BSI Group Headquarters

389 Chiswick High Road London W4 4AL UK

Revisions

Our British Standards and other publications are updated by amendment or revision.

We continually improve the quality of our products and services to benefit your business. If you find an inaccuracy or ambiguity within a British Standard or other BSI publication please inform the Knowledge Centre.

Copyright

All the data, software and documentation set out in all British Standards and other BSI publications are the property of and copyrighted by BSI, or some person or entity that owns copyright in the information used (such as the international standardization bodies) and has formally licensed such information to BSI for commercial publication and use. Except as permitted under the Copyright, Designs and Patents Act 1988 no extract may be reproduced, stored in a retrieval system or transmitted in any form or by any means – electronic, photocopying, recording or otherwise – without prior written permission from BSI. Details and advice can be obtained from the Copyright & Licensing Department.

Useful Contacts:

Customer Services

Tel: +44 845 086 9001

Email (orders): orders@bsigroup.com

Email (enquiries): cservices@bsigroup.com

Subscriptions

Tel: +44 845 086 9001

Email: subscriptions@bsigroup.com

Knowledge Centre

Tel: +44 20 8996 7004

Email: knowledgecentre@bsigroup.com

Copyright & Licensing

Tel: +44 20 8996 7070

Email: copyright@bsigroup.com



...making excellence a habit.™