

BS EN 60034-1:2010



BSI Standards Publication

Rotating electrical machines

Part 1: Rating and performance

NO COPYING WITHOUT BSI PERMISSION EXCEPT AS PERMITTED BY COPYRIGHT LAW

raising standards worldwide[™]



National foreword

This British Standard is the UK implementation of EN 60034-1:2010, incorporating corrigendum October 2010. It was derived by CENELEC from IEC 60034-1:2010. It supersedes BS EN 60034-1:2004, which will be withdrawn on 1 October 2013.

The CENELEC common modifications have been implemented at the appropriate places in the text and are indicated by tags (e.g. **Ⓒ** **Ⓒ**).

The UK participation in its preparation was entrusted to Technical Committee PEL/2, Rotating electrical machinery.

A list of organizations represented on this committee can be obtained on request to its secretary.

This publication does not purport to include all the necessary provisions of a contract. Users are responsible for its correct application.

© BSI 2010

ISBN 978 0 580 63232 7

ICS 29.160.01

Compliance with a British Standard cannot confer immunity from legal obligations.

This British Standard was published under the authority of the Standards Policy and Strategy Committee on 30 November 2010.

Amendments issued since publication

Date	Text affected
------	---------------

English version

**Rotating electrical machines -
Part 1: Rating and performance**
(IEC 60034-1:2010, modified)

Machines électriques tournantes -
Partie 1: Caractéristiques assignées
et caractéristiques de fonctionnement
(CEI 60034-1:2010, modifiée)

Drehende elektrische Maschinen -
Teil 1: Bemessung und Betriebsverhalten
(IEC 60034-1:2010, modifiziert)

This European Standard was approved by CENELEC on 2010-10-01. CENELEC members are bound to comply with the CEN/CENELEC Internal Regulations which stipulate the conditions for giving this European Standard the status of a national standard without any alteration.

Up-to-date lists and bibliographical references concerning such national standards may be obtained on application to the Central Secretariat or to any CENELEC member.

This European Standard exists in three official versions (English, French, German). A version in any other language made by translation under the responsibility of a CENELEC member into its own language and notified to the Central Secretariat has the same status as the official versions.

CENELEC members are the national electrotechnical committees of Austria, Belgium, Bulgaria, Croatia, Cyprus, the Czech Republic, Denmark, Estonia, Finland, France, Germany, Greece, Hungary, Iceland, Ireland, Italy, Latvia, Lithuania, Luxembourg, Malta, the Netherlands, Norway, Poland, Portugal, Romania, Slovakia, Slovenia, Spain, Sweden, Switzerland and the United Kingdom.

CENELEC

European Committee for Electrotechnical Standardization
Comité Européen de Normalisation Electrotechnique
Europäisches Komitee für Elektrotechnische Normung

Management Centre: Avenue Marnix 17, B - 1000 Brussels

Foreword

The text of the International Standard IEC 60034-1:2010, prepared by IEC TC 2, Rotating machinery, together with the common modification prepared by the Technical Committee CENELEC TC 2, Rotating machinery, was submitted to the CENELEC formal vote and was approved by CENELEC as EN 60034-1 on 2010-10-01.

This European Standard supersedes EN 60034-1:2004.

The contents of the corrigendum of October 2010 have been included in this copy.

Attention is drawn to the possibility that some of the elements of this document may be the subject of patent rights. CEN and CENELEC shall not be held responsible for identifying any or all such patent rights.

The following dates were fixed:

- latest date by which the EN has to be implemented
at national level by publication of an identical
national standard or by endorsement (dop) 2011-10-01
- latest date by which the national standards conflicting
with the EN have to be withdrawn (dow) 2013-10-01

This draft European Standard has been prepared under a mandate given to CENELEC by the European Commission and the European Free Trade Association and covers essential requirements of EC Directives 2004/108/EC and 2006/95/EC. See Annex ZZ.

Annex ZA has been added by CENELEC.

Endorsement notice

The text of the International Standard IEC 60034-1:2010 was approved by CENELEC as a European Standard with agreed common modifications.

Annex ZA (normative)

Normative references to international publications with their corresponding European publications

The following referenced documents are indispensable for the application of this document. For dated references, only the edition cited applies. For undated references, the latest edition of the referenced document (including any amendments) applies.

NOTE When an international publication has been modified by common modifications, indicated by (mod), the relevant EN/HD applies.

<u>Publication</u>	<u>Year</u>	<u>Title</u>	<u>EN/HD</u>	<u>Year</u>
IEC 60027-1	-	Letter symbols to be used in electrical technology - Part 1: General	EN 60027-1	-
IEC 60027-4	-	Letter symbols to be used in electrical technology - Part 4: Rotating electrical machines	EN 60027-4	-
IEC 60034-2	Series	Rotating electrical machines - Part 2: Standard methods for determining losses and efficiency from tests (excluding machines for traction vehicles)	EN 60034-2	Series
IEC 60034-3	-	Rotating electrical machines - Part 3: Specific requirements for synchronous generators driven by steam turbines or combustion gas turbines	EN 60034-3	-
IEC 60034-5	-	Rotating electrical machines - Part 5: Degrees of protection provided by the integral design of rotating electrical machines (IP code) - Classification	EN 60034-5	-
IEC 60034-8	-	Rotating electrical machines - Part 8: Terminal markings and direction of rotation	EN 60034-8	-
IEC 60034-12	-	Rotating electrical machines - Part 12: Starting performance of single-speed three-phase cage induction motors	EN 60034-12	-
IEC 60034-15	-	Rotating electrical machines - Part 15: Impulse voltage withstand levels of form-wound stator coils for rotating a.c. machines	EN 60034-15	-
IEC 60034-17	-	Rotating electrical machines - Part 17: Cage induction motors when fed from converters - Application guide	-	-
IEC 60034-18	Series	Rotating electrical machines - Part 18: Functional evaluation of insulation systems	EN 60034-18	Series
IEC 60034-30	-	Rotating electrical machines - Part 30: Efficiency classes of single-speed, three-phase, cage-induction motors (IE code)	EN 60034-30	-
IEC 60038	-	IEC standard voltages	-	-
IEC 60050-411	1996	International Electrotechnical Vocabulary (IEV) - Chapter 411: Rotating machinery	-	-

<u>Publication</u>	<u>Year</u>	<u>Title</u>	<u>EN/HD</u>	<u>Year</u>
IEC 60060-1	-	High-voltage test techniques - Part 1: General definitions and test requirements	HD 588.1	-
IEC 60072	Series	Dimensions and output series for rotating electrical machines	-	-
IEC 60085	-	Electrical insulation - Thermal evaluation and designation	EN 60085	-
IEC 60204-1	-	Safety of machinery - Electrical equipment of machines - Part 1: General requirements	EN 60204-1	-
IEC 60204-11	-	Safety of machinery - Electrical equipment of machines - Part 11: Requirements for HV equipment for voltages above 1 000 V a.c. or 1 500 V d.c. and not exceeding 36 kV	EN 60204-11	-
IEC 60335-1	-	Household and similar electrical appliances - Safety - Part 1: General requirements	EN 60335-1	-
IEC 60445	-	Basic and safety principles for man-machine interface, marking and identification - Identification of equipment terminals and conductor terminations	EN 60445	-
IEC 60664-1	-	Insulation coordination for equipment within low-voltage systems - Part 1: Principles, requirements and tests	EN 60664-1	-
IEC 60971 ¹⁾	-	Semiconductor convertors. Identification code - for convertor connections	-	-
IEC 61293	-	Marking of electrical equipment with ratings related to electrical supply - Safety requirements	EN 61293	-
CISPR 11	-	Industrial, scientific and medical equipment - Radio-frequency disturbance characteristics - Limits and methods of measurement	EN 55011	-
CISPR 14	Series	Electromagnetic compatibility - Requirements for household appliances, electric tools and similar apparatus	EN 55014	Series
CISPR 16	Series	Specification for radio disturbance and immunity measuring apparatus and methods	EN 55016	Series

¹⁾ IEC 60971 was withdrawn and not replaced in 2004.

Annex ZZ (informative)

Coverage of Essential Requirements of EC Directives

This European Standard has been prepared under a mandate given to CENELEC by the European Commission and the European Free Trade Association and within its scope the standard covers all relevant essential requirements as given in Annex I of the EC Directives 2004/108/EC and 2006/95/EC.

Compliance with this standard provides one means of conformity with the specified essential requirements of the Directive concerned.

WARNING: Other requirements and other EC Directives may be applicable to the products falling within the scope of this standard.

Bibliography

In the official version, for Bibliography, the following notes have to be added for the standards indicated:

IEC 60034-6	NOTE	Harmonized as EN 60034-6.
IEC 60034-7	NOTE	Harmonized as EN 60034-7.
IEC 60034-9	NOTE	Harmonized as EN 60034-9.
IEC 60034-11	NOTE	Harmonized as EN 60034-11.
IEC 60034-14	NOTE	Harmonized as EN 60034-14.
IEC 60034-29	NOTE	Harmonized as EN 60034-29.
IEC 60079 series	NOTE	Harmonized in EN 60079 series (partially modified).
IEC 60349 series	NOTE	Harmonized in EN 60349 series (partially modified).

CONTENTS

1 Scope.....7

2 Normative references7

3 Terms and definitions8

4 Duty 13

 4.1 Declaration of duty 13

 4.2 Duty types 13

5 Rating 26

 5.1 Assignment of rating.....26

 5.2 Classes of rating26

 5.3 Selection of a class of rating27

 5.4 Allocation of outputs to class of rating27

 5.5 Rated output28

 5.6 Rated voltage28

 5.7 Co-ordination of voltages and outputs28

 5.8 Machines with more than one rating29

6 Site operating conditions 29

 6.1 General29

 6.2 Altitude.....29

 6.3 Maximum ambient air temperature.....29

 6.4 Minimum ambient air temperature29

 6.5 Water coolant temperature29

 6.6 Storage and transport.....30

 6.7 Purity of hydrogen coolant.....30

7 Electrical operating conditions 30

 7.1 Electrical supply30

 7.2 Form and symmetry of voltages and currents30

 7.3 Voltage and frequency variations during operation33

 7.4 Three-phase a.c. machines operating on unearthed systems.....35

 7.5 Voltage (peak and gradient) withstand levels.....35

8 Thermal performance and tests 35

 8.1 Thermal class.....35

 8.2 Reference coolant35

 8.3 Conditions for thermal tests36

 8.4 Temperature rise of a part of a machine37

 8.5 Methods of measurement of temperature.....37

 8.6 Determination of winding temperature38

 8.7 Duration of thermal tests41

 8.8 Determination of the thermal equivalent time constant for machines of duty type S9.....41

 8.9 Measurement of bearing temperature42

 8.10 Limits of temperature and of temperature rise42

9 Other performance and tests 50

 9.1 Routine tests50

 9.2 Withstand voltage test51

9.3	Occasional excess current.....	53
9.4	Momentary excess torque for motors.....	54
9.5	Pull-up torque.....	55
9.6	Safe operating speed of cage induction motors	55
9.7	Overspeed	56
9.8	Short-circuit current for synchronous machines	57
9.9	Short-circuit withstand test for synchronous machines.....	57
9.10	Commutation test for commutator machines	58
9.11	Total harmonic distortion (<i>THD</i>) for synchronous machines	58
10	Rating plates	58
10.1	General	58
10.2	Marking	59
11	Miscellaneous requirements	60
11.1	Protective earthing of machines	60
11.2	Shaft-end key(s).....	62
12	Tolerances	62
12.1	General	62
12.2	Tolerances on values of quantities	62
13	Electromagnetic compatibility (EMC)	64
13.1	General	64
13.2	Immunity	64
13.3	Emission	65
13.4	Immunity tests	65
13.5	Emission tests.....	65
14	Safety.....	65
	Annex A (informative) Guidance for the application of duty type S10 and for establishing the value of relative thermal life expectancy <i>TL</i>	67
	Annex B (informative) Electromagnetic compatibility (EMC) limits	68
	Bibliography.....	69
	Figure 1 – Continuous running duty – Duty type S1.....	14
	Figure 2 – Short-time duty – Duty type S2.....	15
	Figure 3 – Intermittent periodic duty – Duty type S3.....	16
	Figure 4 – Intermittent periodic duty with starting – Duty type S4	17
	Figure 5 – Intermittent periodic duty with electric braking – Duty type S5	18
	Figure 6 – Continuous operation periodic duty – Duty type S6	19
	Figure 7 – Continuous operation periodic duty with electric braking – Duty type S7	20
	Figure 8 – Continuous operation periodic duty with related load/speed changes – Duty type S8.....	22
	Figure 9 – Duty with non-periodic load and speed variations – Duty type S9.....	23
	Figure 10 – Duty with discrete constant loads – Duty type S10	25
	Figure 11 – Voltage and frequency limits for generators.....	34
	Figure 12 – Voltage and frequency limits for motors.....	34
	Table 1 – Preferred voltage ratings	29
	Table 2 – Unbalanced operating conditions for synchronous machines	32

Table 3 – Primary functions of machines.....	34
Table 4 – Reference coolant (see also Table 10)	36
Table 5 – Time interval	40
Table 6 – Measuring points.....	42
Table 7 – Limits of temperature rise of windings indirectly cooled by air	44
Table 8 – Limits of temperature rise of windings indirectly cooled by hydrogen	45
Table 9 – Adjustments to limits of temperature rise at the operating site of indirect cooled windings to take account of non-reference operating conditions and ratings	45
Table 10 – Assumed maximum ambient temperature	47
Table 11 – Adjusted limits of temperature rise at the test site ($\Delta\theta_T$) for windings indirectly cooled by air to take account of test site operating conditions	48
Table 12 – Limits of temperature of directly cooled windings and their coolants	49
Table 13 – Adjustments to limits of temperature at the operating site for windings directly cooled by air or hydrogen to take account of non-reference operating conditions and ratings	50
Table 14 – Adjusted limits of temperature at the test site θ_T for windings directly cooled by air to take account of test site operating conditions	50
Table 15 – Minimum schedule of routine tests	51
Table 16 – Withstand voltage tests	52
Table 17 – Maximum safe operating speed (min^{-1}) of three-phase single-speed cage induction motors for voltages up to and including 1 000 V.....	56
Table 18 – Overspeeds.....	57
Table 19 – Cross-sectional areas of earthing conductors	62
Table 20 – Schedule of tolerances on values of quantities	63
Table B.1 – Electromagnetic emission limits for machines without brushes	68
Table B.2 – Electromagnetic emission limits for machines with brushes	68

ROTATING ELECTRICAL MACHINES –

Part 1: Rating and performance

1 Scope

This part of IEC 60034 is applicable to all rotating electrical machines except those covered by other IEC standards, for example, IEC 60349 [10]¹⁾.

Machines within the scope of this standard may also be subject to superseding, modifying or additional requirements in other publications, for example, IEC 60079 [8] and IEC 60092 [9].

NOTE If particular clauses of this standard are modified to meet special applications, for example machines subject to radioactivity or machines for aerospace, all other clauses apply insofar as they are compatible.

2 Normative references

The following referenced documents are indispensable for the application of this document. For dated references, only the edition cited applies. For undated references, the latest edition of the referenced document (including any amendments) applies.

IEC 60027-1, *Letter symbols to be used in electrical technology – Part 1: General*

IEC 60027-4, *Letter symbols to be used in electrical technology – Part 4: Rotating electrical machines*

IEC 60034-2 (all parts), *Rotating electrical machines – Part 2: Standard methods for determining losses and efficiency from tests (excluding machines for traction vehicles)*

IEC 60034-3, *Rotating electrical machines – Part 3: Specific requirements for synchronous generators driven by steam turbines or combustion gas turbines*

IEC 60034-5, *Rotating electrical machines – Part 5: Degrees of protection provided by the integral design of rotating electrical machines (IP code) – Classification*

IEC 60034-8, *Rotating electrical machines – Part 8: Terminal markings and direction of rotation*

IEC 60034-12, *Rotating electrical machines – Part 12: Starting performance of single-speed three-phase cage induction motors*

IEC 60034-15, *Rotating electrical machines – Part 15: Impulse voltage withstand levels of form-wound stator coils for rotating a.c. machines*

IEC 60034-17, *Rotating electrical machines – Part 17: Cage induction motors when fed from converters – Application guide*

IEC 60034-18 (all parts), *Rotating electrical machines – Part 18: Functional evaluation of insulating systems*

¹⁾ Figures in square brackets refer to the Bibliography.

IEC 60034-30, *Rotating electrical machines – Part 30: Efficiency classes of single-speed, three-phase, cage-induction motors (IE-code)*

IEC 60038, *IEC standard voltages*

IEC 60050-411:1996, *International Electrotechnical Vocabulary (IEV) – Chapter 411: Rotating machines*

IEC 60060-1, *High-voltage test techniques – Part 1: General definitions and test requirements*

IEC 60072 (all parts), *Dimensions and output series for rotating electrical machines*

IEC 60085, *Electrical insulation – Thermal evaluation and designation*

IEC 60204-1, *Safety of machinery – Electrical equipment of machines – Part 1: General requirements*

IEC 60204-11, *Safety of machinery – Electrical equipment of machines – Part 11: Requirements for HV equipment for voltages above 1 000 V a.c. or 1 500 V d.c. and not exceeding 36 kV*

IEC 60335-1, *Household and similar electrical appliances – Safety – Part 1: General requirements*

IEC 60445, *Basic and safety principles for man-machine interface, marking and identification – Identification of equipment terminals and conductor terminals*

IEC 60664-1, *Insulation coordination for equipment within low-voltage systems – Part 1: Principles, requirements and tests*

IEC 60971, *Semiconductor convertors. Identification code for convertor connections²⁾*

IEC 61293, *Marking of electrical equipment with ratings related to electrical supply – Safety requirements*

CISPR 11, *Industrial, scientific and medical equipment – Radiofrequency disturbance characteristics – Limits and methods of measurement*

CISPR 14 (all parts), *Electromagnetic compatibility – Requirements for household appliances, electric tools and similar apparatus*

CISPR 16 (all parts), *Specification for radio disturbance and immunity measuring apparatus and methods*

3 Terms and definitions

For the purposes of this document, the terms and definitions in IEC 60050-411, some of which are repeated here for convenience, and the following terms and definitions apply.

NOTE 1 For definitions concerning cooling and coolants, other than those in 3.17 to 3.22, reference should be made to IEC 60034-6 [1].

²⁾ IEC 60971 was withdrawn (and not replaced) in 2004.

NOTE 2 For the purposes of this standard, the term 'agreement' means 'agreement between the manufacturer and purchaser'.

3.1

rated value

a quantity value assigned, generally by a manufacturer, for a specified operating condition of a machine

[IEV 411-51-23]

NOTE The rated voltage or voltage range is the rated voltage or voltage range between lines at the terminals.

3.2

rating

the set of rated values and operating conditions

[IEV 411-51-24]

3.3

rated output

the value of the output included in the rating

3.4

load

all the values of the electrical and mechanical quantities that signify the demand made on a rotating machine by an electrical circuit or a mechanism at a given instant

[IEV 411-51-01]

3.5

no-load (operation)

the state of a machine rotating with zero output power (but under otherwise normal operating conditions)

[IEV 411-51-02, modified]

3.6

full load

the load which causes a machine to operate at its rating

[IEV 411-51-10]

3.7

full load value

a quantity value for a machine operating at full load

[IEV 411-51-11]

NOTE This concept applies to power, torque, current, speed, etc.

3.8

de-energized and rest

the complete absence of all movement and of all electrical supply or mechanical drive

[IEV 411-51-03]

3.9

duty

the statement of the load(s) to which the machine is subjected, including, if applicable, starting, electric braking, no-load and rest and de-energized periods, and including their durations and sequence in time

[IEV 411-51-06]

3.10 duty type

a continuous, short-time or periodic duty, comprising one or more loads remaining constant for the duration specified, or a non-periodic duty in which generally load and speed vary within the permissible operating range

[IEV 411-51-13]

3.11 cyclic duration factor

the ratio between the period of loading, including starting and electric braking, and the duration of the duty cycle, expressed as a percentage

[IEV 411-51-09]

3.12 locked-rotor torque

the smallest measured torque the motor develops at its shaft and with the rotor locked, over all its angular positions, at rated voltage and frequency

[IEV 411-48-06]

3.13 locked-rotor current

the greatest steady-state r.m.s. current taken from the line with the motor held at rest, over all angular positions of its rotor, at rated voltage and frequency

[IEV 411-48-16]

3.14 pull-up torque (of an a.c. motor)

the smallest steady-state asynchronous torque which the motor develops between zero speed and the speed which corresponds to the breakdown torque, when the motor is supplied at the rated voltage and frequency

This definition does not apply to those asynchronous motors of which the torque continually decreases with increase in speed.

NOTE In addition to the steady-state asynchronous torques, harmonic synchronous torques, which are a function of rotor load angle, will be present at specific speeds.

At such speeds, the accelerating torque may be negative for some rotor load angles.

Experience and calculation show this to be an unstable operating condition and therefore harmonic synchronous torques do not prevent motor acceleration and are excluded from this definition.

3.15 breakdown torque (of an a.c. motor)

the maximum steady-state asynchronous torque which the motor develops without an abrupt drop in speed, when the motor is supplied at the rated voltage and frequency

This definition does not apply to motors with torques that continually decrease with increase in speed.

3.16 pull-out torque (of a synchronous motor)

the maximum torque which the synchronous motor develops at synchronous speed with rated voltage, frequency and field current

3.17
cooling

a procedure by means of which heat resulting from losses occurring in a machine is given up to a primary coolant, which may be continuously replaced or may itself be cooled by a secondary coolant in a heat exchanger

[IEV 411-44-01]

3.18
coolant

a medium, liquid or gas, by means of which heat is transferred

[IEV 411-44-02]

3.19
primary coolant

a medium, liquid or gas, which, being at a lower temperature than a part of a machine and in contact with it, removes heat from that part

[IEV 411-44-03]

3.20
secondary coolant

a medium, liquid or gas, which, being at a lower temperature than the primary coolant, removes the heat given up by this primary coolant by means of a heat exchanger or through the external surface of the machine

[IEV 411-44-04]

3.21
direct cooled winding
inner cooled winding

a winding mainly cooled by coolant flowing in direct contact with the cooled part through hollow conductors, tubes, ducts or channels which, regardless of their orientation, form an integral part of the winding inside the main insulation

[IEV 411-44-08]

NOTE In all cases when 'indirect' or 'direct' is not stated, an indirect cooled winding is implied.

3.22
indirect cooled winding

any winding other than a direct cooled winding

NOTE In all cases when 'indirect' or 'direct' is not stated, an indirect cooled winding is implied.

[IEV 411-44-09]

3.23
supplementary insulation

an independent insulation applied in addition to the main insulation in order to ensure protection against electric shock in the event of failure of the main insulation

3.24
moment of inertia

the sum (integral) of the products of the mass elements of a body and the squares of their distances (radii) from a given axis

3.25**thermal equilibrium**

the state reached when the temperature rises of the several parts of the machine do not vary by more than a gradient of 2 K per hour

[IEV 411-51-08]

NOTE Thermal equilibrium may be determined from the time-temperature rise plot when the straight lines between points at the beginning and end of two successive reasonable intervals each have a gradient of less than 2 K per hour.

3.26**thermal equivalent time constant**

the time constant, replacing several individual time constants, which determines approximately the temperature course in a winding after a step-wise current change

3.27**encapsulated winding**

a winding which is completely enclosed or sealed by moulded insulation

[IEV 411-39-06]

3.28**rated form factor of direct current supplied to a d.c. motor armature from a static power converter**

the ratio of the r.m.s. maximum permissible value of the current $I_{\text{rms,maxN}}$ to its average value I_{avN} (mean value integrated over one period) at rated conditions:

$$k_{\text{fN}} = \frac{I_{\text{rms,maxN}}}{I_{\text{avN}}}$$

3.29**current ripple factor**

the ratio of the difference between the maximum value I_{max} and the minimum value I_{min} of an undulating current to two times the average value I_{av} (mean value integrated over one period):

$$q_i = \frac{I_{\text{max}} - I_{\text{min}}}{2 \times I_{\text{av}}}$$

NOTE For small values of current ripple, the ripple factor may be approximated by the following expression:

$$q_i = \frac{I_{\text{max}} - I_{\text{min}}}{I_{\text{max}} + I_{\text{min}}}$$

The above expression may be used as an approximation if the resulting calculated value of q_i is equal to or less than 0,4.

3.30**tolerance**

the permitted deviation between the declared value of a quantity and the measured value

3.31**type test**

a test of one or more machines made to a certain design to show that the design meets certain specifications

[IEV 411-53-01]

NOTE The type test may also be considered valid if it is made on a machine which has minor deviations of rating or other characteristics. These deviations should be subject to agreement.

3.32

routine test

a test to which each individual machine is subjected during or after manufacture to ascertain whether it complies with certain criteria

[IEV 411-53-02]

3.33

runaway speed

the maximum speed attained by the engine/generator set after removal of the full load of the generator if the speed regulator does not function

[IEV 811-17-23]

NOTE For motors, the maximum overspeed at loss of supply is meant that a motor might reach driven by the coupled equipment

4 Duty

4.1 Declaration of duty

It is the responsibility of the purchaser to declare the duty. The purchaser may describe the duty by one of the following:

- a) numerically, where the load does not vary or where it varies in a known manner;
- b) as a time sequence graph of the variable quantities;
- c) by selecting one of the duty types S1 to S10 that is no less onerous than the expected duty.

The duty type shall be designated by the appropriate abbreviation, specified in 4.2, written after the value of the load.

An expression for the cyclic duration factor is given in the relevant duty type figure.

The purchaser normally cannot provide values for the moment of inertia of the motor (J_M) or the relative thermal life expectancy (TL), see Annex A. These values are provided by the manufacturer.

Where the purchaser does not declare a duty, the manufacturer shall assume that duty type S1 (continuous running duty) applies.

4.2 Duty types

4.2.1 Duty type S1 – Continuous running duty

Operation at a constant load maintained for sufficient time to allow the machine to reach thermal equilibrium, see Figure 1.

The appropriate abbreviation is S1.

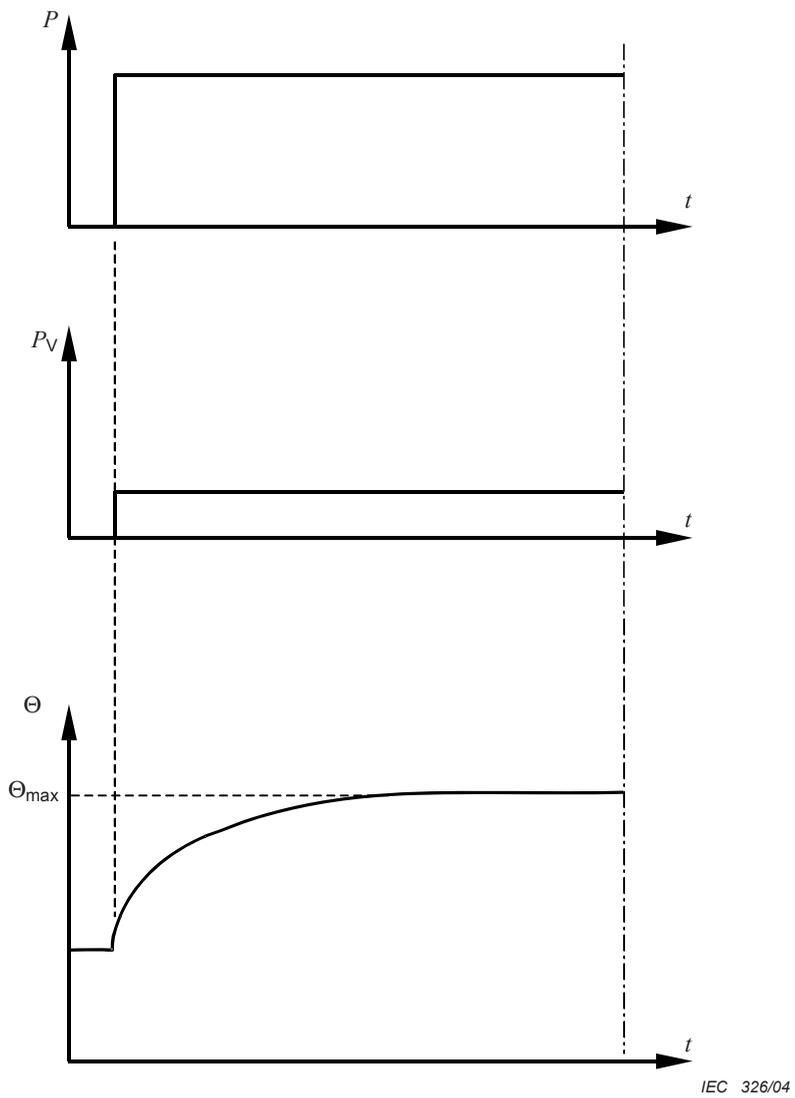

Key

- P load
- P_V electrical losses
- Θ temperature
- Θ_{max} maximum temperature attained
- t time

Figure 1 – Continuous running duty – Duty type S1

4.2.2 Duty type S2 – Short-time duty

Operation at constant load for a given time, less than that required to reach thermal equilibrium, followed by a time de-energized and at rest of sufficient duration to re-establish machine temperatures within 2 K of the coolant temperature, see Figure 2.

The appropriate abbreviation is S2, followed by an indication of the duration of the duty,

Example: S2 60 min.

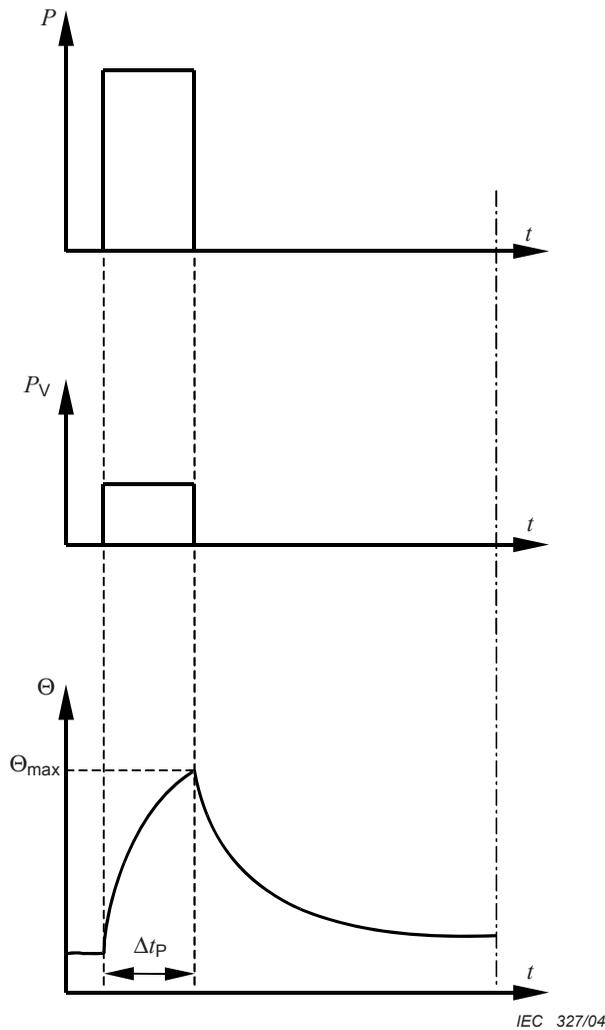

Key

- P load
- P_V electrical losses
- Θ temperature
- Θ_{max} maximum temperature attained
- t time
- Δt_p operation time at constant load

Figure 2 – Short-time duty – Duty type S2

4.2.3 Duty type S3 – Intermittent periodic duty

NOTE Periodic duty implies that thermal equilibrium is not reached during the time on load.

A sequence of identical duty cycles, each including a time of operation at constant load and a time de-energized and at rest, see Figure 3. In this duty, the cycle is such that the starting current does not significantly affect the temperature rise.

The appropriate abbreviation is S3, followed by the cyclic duration factor.

Example: S3 25 %

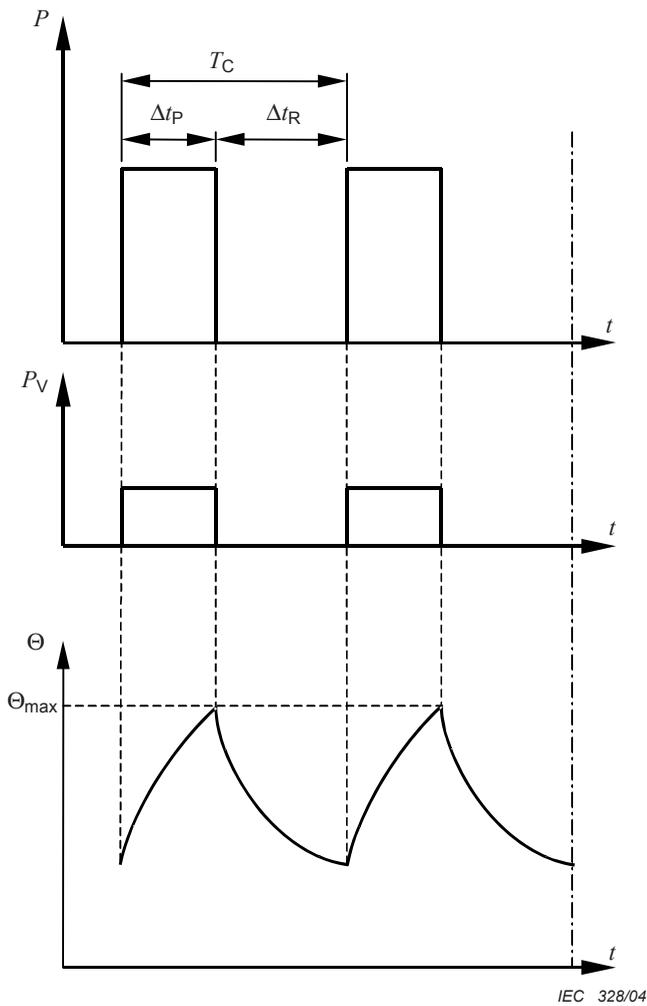

Key

- P load
- P_V electrical losses
- Θ temperature
- Θ_{max} maximum temperature attained
- t time
- T_C time of one load cycle
- Δt_P operation time at constant load
- Δt_R time de-energized and at rest
- Cyclic duration factor = $\Delta t_P / T_C$

Figure 3 – Intermittent periodic duty – Duty type S3

4.2.4 Duty type S4 – Intermittent periodic duty with starting

NOTE Periodic duty implies that thermal equilibrium is not reached during the time on load.

A sequence of identical duty cycles, each cycle including a significant starting time, a time of operation at constant load and a time de-energized and at rest, see Figure 4.

The appropriate abbreviation is S4, followed by the cyclic duration factor, the moment of inertia of the motor (J_M) and the moment of inertia of the load (J_{ext}), both referred to the motor shaft.

Example: S4 25 % $J_M = 0,15 \text{ kg} \times \text{m}^2$ $J_{ext} = 0,7 \text{ kg} \times \text{m}^2$

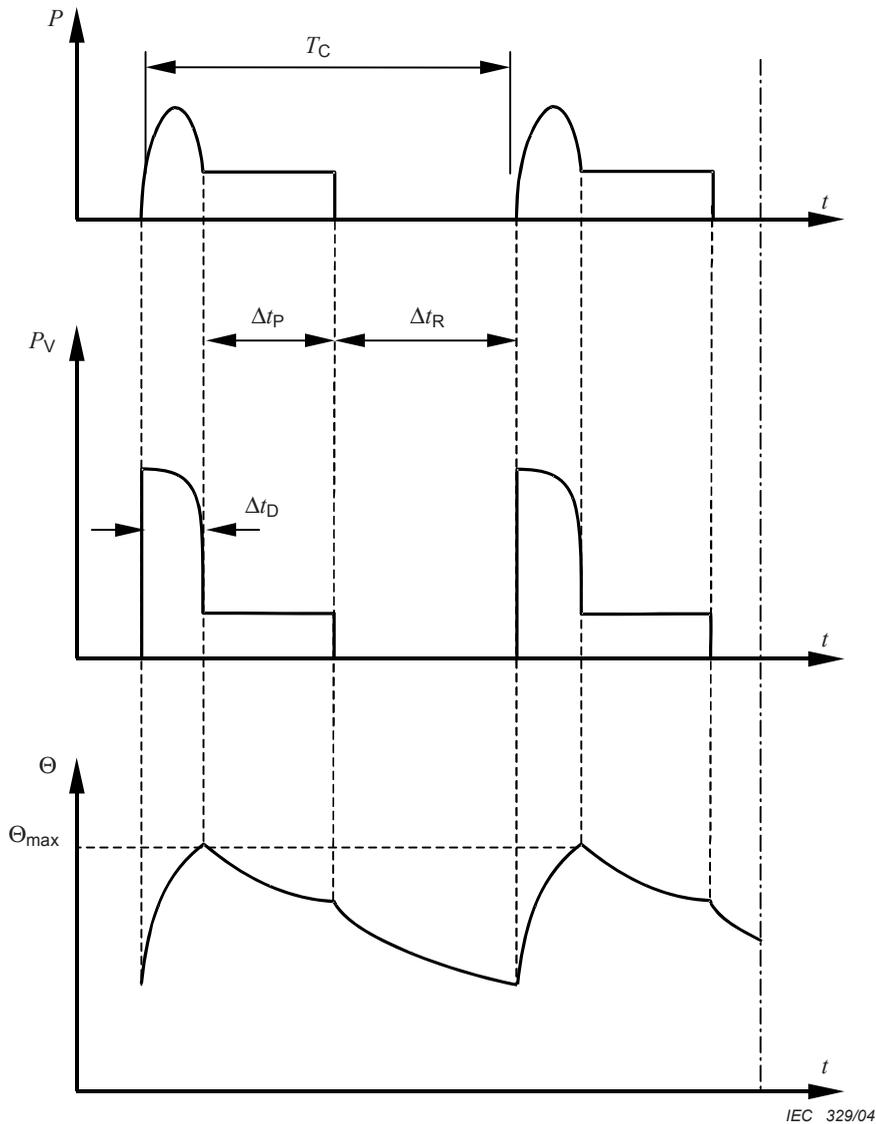

Key

P	load	t	time
P_V	electrical losses	T_C	time of one load cycle
Θ	temperature	Δt_D	starting/accelerating time
Θ_{max}	maximum temperature attained	Δt_P	operation time at constant load
		Δt_R	time de-energized and at rest

Cyclic duration factor = $(\Delta t_D + \Delta t_P) / T_C$

Figure 4 – Intermittent periodic duty with starting – Duty type S4

4.2.5 Duty type S5 – Intermittent periodic duty with electric braking

NOTE Periodic duty implies that thermal equilibrium is not reached during the time on load.

A sequence of identical duty cycles, each cycle consisting of a starting time, a time of operation at constant load, a time of electric braking and a time de-energized and at rest, see Figure 5.

The appropriate abbreviation is S5, followed by the cyclic duration factor, the moment of inertia of the motor (J_M) and the moment of inertia of the load (J_{ext}), both referred to the motor shaft.

Example: S5 25 % $J_M = 0,15 \text{ kg} \times \text{m}^2$ $J_{ext} = 0,7 \text{ kg} \times \text{m}^2$

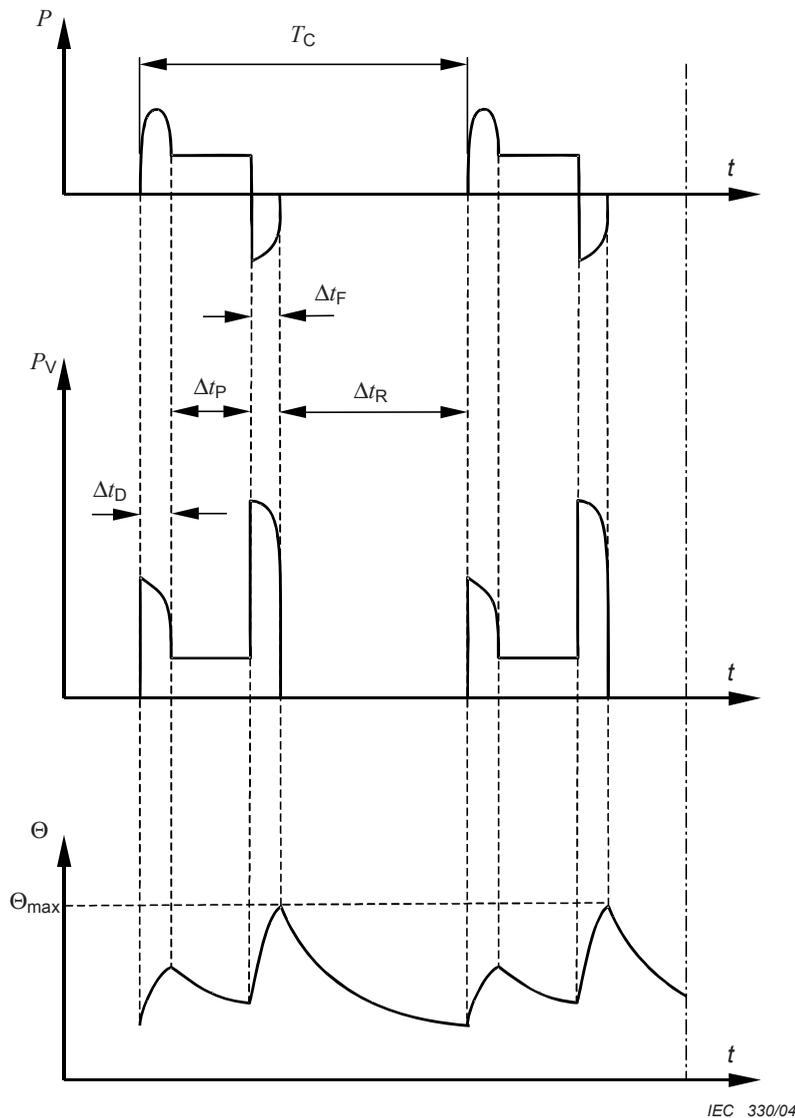

Key

P	load	T_C	time of one load cycle
P_V	electrical losses	Δt_D	starting/accelerating time
Θ	temperature	Δt_P	operation time at constant load
Θ_{max}	maximum temperature attained	Δt_F	time of electric braking
t	time	Δt_R	time de-energized and at rest

Cyclic duration factor = $(\Delta t_D + \Delta t_P + \Delta t_F)/T_C$

Figure 5 – Intermittent periodic duty with electric braking – Duty type S5

4.2.6 Duty type S6 – Continuous operation periodic duty

NOTE Periodic duty implies that thermal equilibrium is not reached during the time on load.

A sequence of identical duty cycles, each cycle consisting of a time of operation at constant load and a time of operation at no-load. There is no time de-energized and at rest, see Figure 6.

The appropriate abbreviation is S6, followed by the cyclic duration factor.

Example: S6 40 %

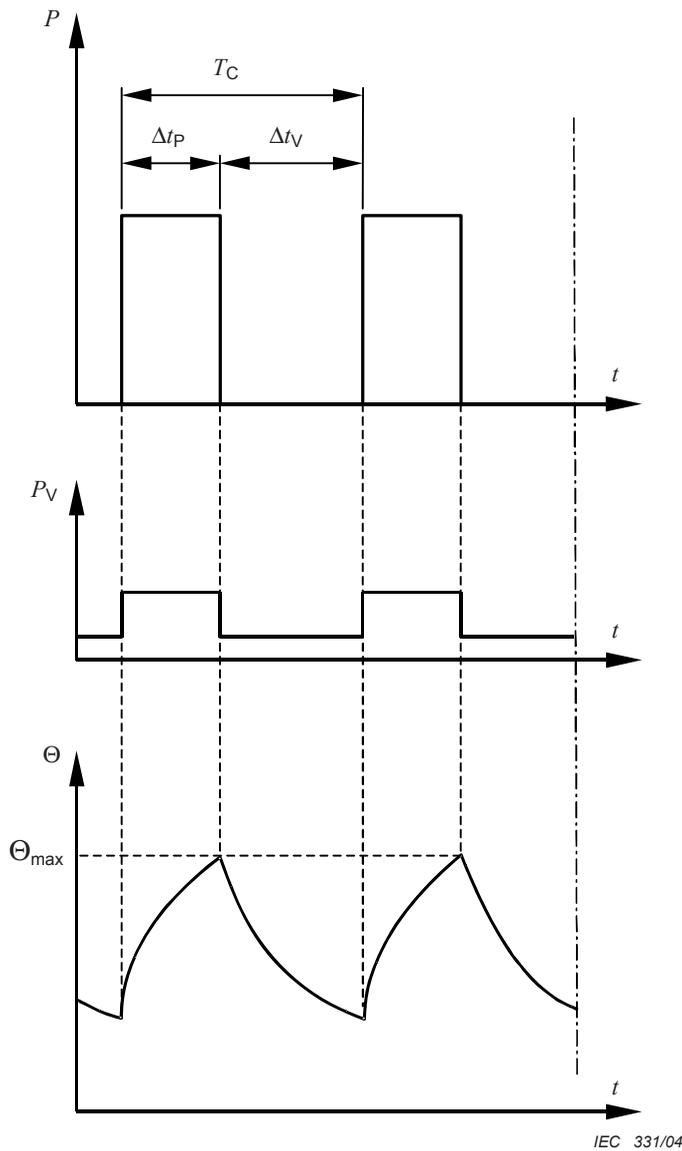

Key

P	load	t	time
P_V	electrical losses	T_C	time of one load cycle
Θ	temperature	Δt_P	operation time at constant load
Θ_{max}	maximum temperature attained	Δt_V	operation time at no-load
Cyclic duration factor = $\Delta t_P / T_C$			

Figure 6 – Continuous operation periodic duty – Duty type S6

4.2.7 Duty type S7 – Continuous operation periodic duty with electric braking

NOTE Periodic duty implies that thermal equilibrium is not reached during the time on load.

A sequence of identical duty cycles, each cycle consisting of a starting time, a time of operation at constant load and a time of electric braking. There is no time de-energized and at rest, see Figure 7.

The appropriate abbreviation is S7, followed by the moment of inertia of the motor (J_M) and the moment of inertia of the load (J_{ext}), both referred to the motor shaft.

Example: S7 $J_M = 0,4 \text{ kg} \times \text{m}^2$ $J_{ext} = 7,5 \text{ kg} \times \text{m}^2$

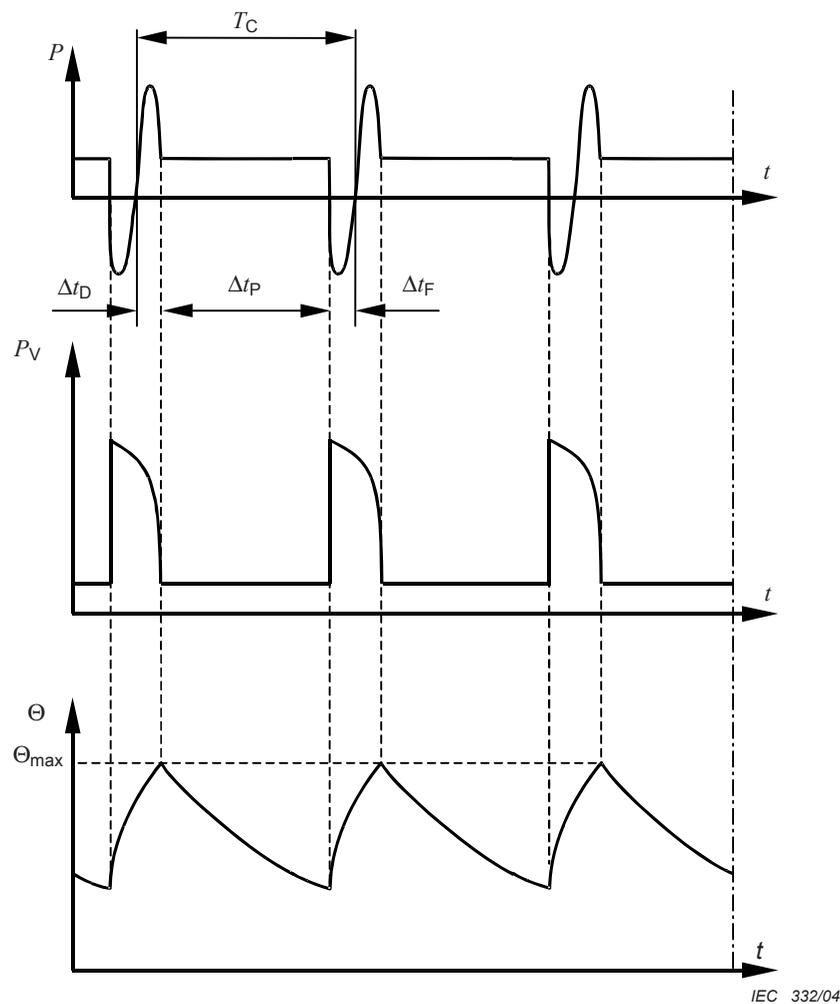

Key

P	load	t	time
P_V	electrical losses	T_C	time of one load cycle
Θ	temperature	Δt_D	starting/accelerating time
Θ_{max}	maximum temperature attained	Δt_P	operation time at constant load
Cyclic duration factor = 1		Δt_F	time of electric braking

Figure 7 – Continuous operation periodic duty with electric braking – Duty type S7

4.2.8 Duty type S8 – Continuous operation periodic duty with related load/speed changes

NOTE Periodic duty implies that thermal equilibrium is not reached during the time on load.

A sequence of identical duty cycles, each cycle consisting of a time of operation at constant load corresponding to a predetermined speed of rotation, followed by one or more times of operation at other constant loads corresponding to different speeds of rotation (carried out, for example, by means of a change in the number of poles in the case of induction motors). There is no time de-energized and at rest (see Figure 8).

The appropriate abbreviation is S8, followed by the moment of inertia of the motor (J_M) and the moment of inertia of the load (J_{ext}), both referred to the motor shaft, together with the load, speed and cyclic duration factor for each speed condition.

Example:	S8	$J_M = 0,5 \text{ kg} \times \text{m}^2$	$J_{ext} = 6 \text{ kg} \times \text{m}^2$	16 kW	740 min^{-1}	30 %
				40 kW	1 460 min^{-1}	30 %
				25 kW	980 min^{-1}	40 %

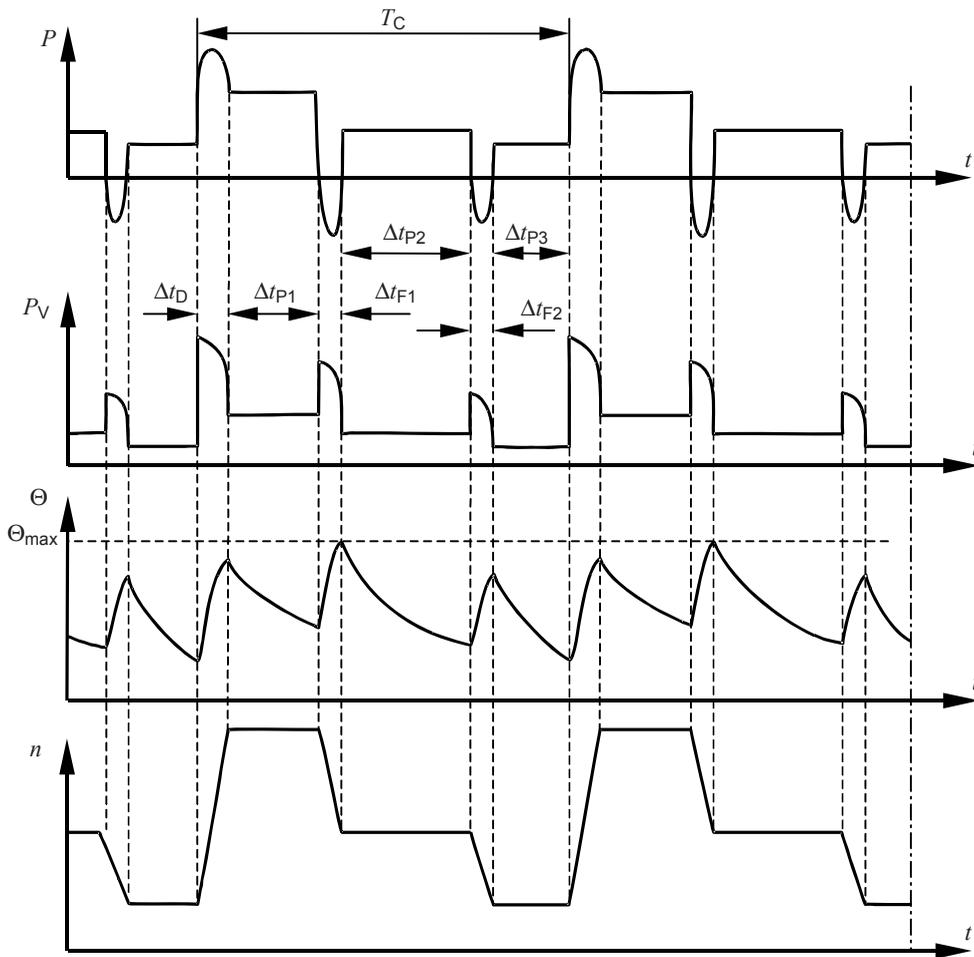

IEC 333/04

Key

P	load	t	time
P_V	electrical losses	T_C	time of one load cycle
Θ	temperature	Δt_D	starting/accelerating time
Θ_{max}	maximum temperature attained	Δt_P	operation time at constant load (P1, P2, P3)
n	speed	Δt_F	time of electric braking (F1, F2)

Cyclic duration factor = $(\Delta t_D + \Delta t_{P1})/T_C$; $(\Delta t_{F1} + \Delta t_{P2})/T_C$; $(\Delta t_{F2} + \Delta t_{P3})/T_C$

Figure 8 – Continuous operation periodic duty with related load/speed changes – Duty type S8

4.2.9 Duty type S9 – Duty with non-periodic load and speed variations

A duty in which generally load and speed vary non-periodically within the permissible operating range. This duty includes frequently applied overloads that may greatly exceed the reference load (see Figure 9).

The appropriate abbreviation is S9.

For this duty type, a constant load appropriately selected and based on duty type S1 is taken as the reference value (" P_{ref} " in Figure 9) for the overload concept.

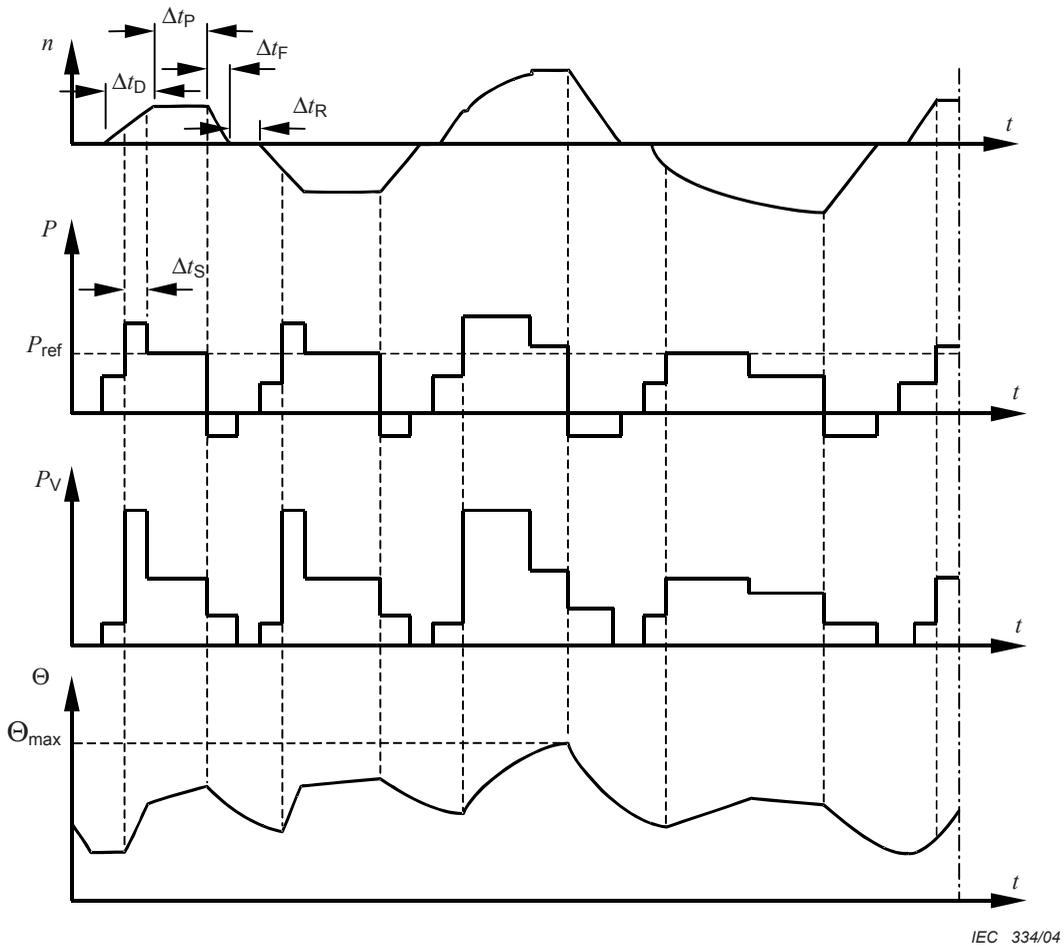

IEC 334/04

Key

P	load	t	time
P_{ref}	reference load	Δt_D	starting/accelerating time
P_V	electrical losses	Δt_P	operation time at constant load
Θ	temperature	Δt_F	time of electric braking
Θ_{max}	maximum temperature attained	Δt_R	time de-energized and at rest
n	speed	Δt_S	time under overload

Figure 9 – Duty with non-periodic load and speed variations – Duty type S9

4.2.10 Duty type S10 – Duty with discrete constant loads and speeds

A duty consisting of a specific number of discrete values of load (or equivalent loading) and if applicable, speed, each load/speed combination being maintained for sufficient time to allow the machine to reach thermal equilibrium, see Figure 10. The minimum load within a duty cycle may have the value zero (no-load or de-energized and at rest).

The appropriate abbreviation is S10, followed by the per unit quantities $p/\Delta t$ for the respective load and its duration and the per unit quantity TL for the relative thermal life expectancy of the insulation system. The reference value for the thermal life expectancy is the thermal life expectancy at rating for continuous running duty and permissible limits of temperature rise based on duty type S1. For a time de-energized and at rest, the load shall be indicated by the letter r .

Example: S10 $p/\Delta t = 1,1/0,4; 1/0,3; 0,9/0,2; r/0,1$ $TL = 0,6$

The value of TL should be rounded off to the nearest multiple of 0,05. Advice concerning the significance of this parameter and the derivation of its value is given in Annex A.

For this duty type a constant load appropriately selected and based on duty type S1 shall be taken as the reference value (P_{ref} in Figure 10) for the discrete loads.

NOTE The discrete values of load will usually be equivalent loading based on integration over a period of time. It is not necessary that each load cycle be exactly the same, only that each load within a cycle be maintained for sufficient time for thermal equilibrium to be reached, and that each load cycle be capable of being integrated to give the same relative thermal life expectancy.

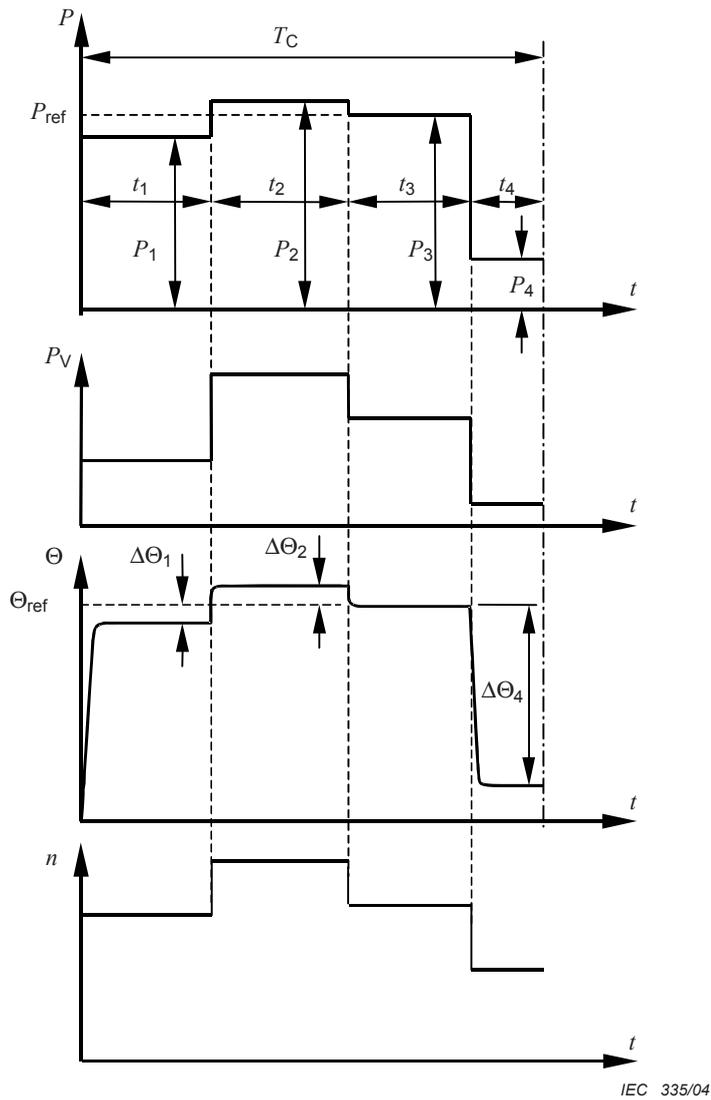

IEC 335/04

Key

P	load	t	time
P_i	constant load within a load cycle	t_i	time of a constant load within a cycle
P_{ref}	reference load based on duty type S1	T_C	time of one load cycle
P_V	electrical losses	$\Delta\Theta_i$	difference between the temperature rise of the winding at each of the various loads within one cycle and the temperature rise based on duty cycle S1 with reference load
Θ	temperature	n	speed
Θ_{ref}	temperature at reference load based on duty type S1		

Figure 10 – Duty with discrete constant loads – Duty type S10

5 Rating

5.1 Assignment of rating

The rating, as defined in 3.2, shall be assigned by the manufacturer. In assigning the rating the manufacturer shall select one of the classes of rating defined in 5.2.1 to 5.2.6. The designation of the class of rating shall be written after the rated output. If no designation is stated, rating for continuous running duty applies.

When accessory components (such as reactors, capacitors, etc.) are connected by the manufacturer as part of the machine, the rated values shall refer to the supply terminals of the whole arrangement.

NOTE This does not apply to power transformers connected between the machine and the supply.

Special considerations are required when assigning ratings to machines fed from or supplying static converters. IEC 60034-17 gives guidance for the case of cage induction motors covered in IEC 60034-12.

5.2 Classes of rating

5.2.1 Rating for continuous running duty

A rating at which the machine may be operated for an unlimited period, while complying with the requirements of this standard.

This class of rating corresponds to duty type S1 and is designated as for the duty type S1.

5.2.2 Rating for short-time duty

A rating at which the machine may be operated for a limited period, starting at ambient temperature, while complying with the requirements of this standard.

This class of rating corresponds to duty type S2 and is designated as for the duty type S2.

5.2.3 Rating for periodic duty

A rating at which the machine may be operated on duty cycles, while complying with the requirements of this standard.

This class of rating corresponds to one of the periodic duty types S3 to S8 and is designated as for the corresponding duty type.

Unless otherwise specified, the duration of a duty cycle shall be 10 min and the cyclic duration factor shall be one of the following values:

15 %, 25 %, 40 %, 60 %.

5.2.4 Rating for non-periodic duty

A rating at which the machine may be operated non-periodically while complying with the requirements of this standard.

This class of rating corresponds to the non-periodic duty type S9 and is designated as for the duty type S9.

5.2.5 Rating for duty with discrete constant loads and speeds

A rating at which the machine may be operated with the associated loads and speeds of duty type S10 for an unlimited period of time while complying with the requirements of this standard. The maximum permissible load within one cycle shall take into consideration all parts of the machine, for example, the insulation system regarding the validity of the exponential law for the relative thermal life expectancy, bearings with respect to temperature, other parts with respect to thermal expansion. Unless specified in other relevant IEC standards, the maximum load shall not exceed 1,15 times the value of the load based on duty type S1. The minimum load may have the value zero, the machine operating at no-load or being de-energized and at rest. Considerations for the application of this class of rating are given in Annex A.

This class of rating corresponds to the duty type S10 and is designated as for the duty type S10.

NOTE Other relevant IEC standards may specify the maximum load in terms of limiting winding temperature (or temperature rise) instead of per unit load based on duty type S1.

5.2.6 Rating for equivalent loading

A rating, for test purposes, at which the machine may be operated at constant load until thermal equilibrium is reached and which results in the same stator winding temperature rise as the average temperature rise during one load cycle of the specified duty type.

NOTE The determination of an equivalent rating should take account of the varying load, speed and cooling of the duty cycle.

This class of rating, if applied, is designated 'equ'.

5.3 Selection of a class of rating

A machine manufactured for general purpose shall have a rating for continuous running duty and be capable of performing duty type S1.

If the duty has not been specified by the purchaser, duty type S1 applies and the rating assigned shall be a rating for continuous running duty.

When a machine is intended to have a rating for short-time duty, the rating shall be based on duty type S2, see 4.2.2.

When a machine is intended to supply varying loads or loads including a time of no-load or times where the machine will be in a state of de-energized and at rest, the rating shall be a rating for periodic duty based on a duty type selected from duty types S3 to S8, see 4.2.3 to 4.2.8.

When a machine is intended non-periodically to supply variable loads at variable speeds, including overloads, the rating shall be a rating for non-periodic duty based on duty type S9, see 4.2.9.

When a machine is intended to supply discrete constant loads including times of overload or times of no-load (or de-energized and at rest) the rating shall be a rating with discrete constant loads based on duty type S10, see 4.2.10.

5.4 Allocation of outputs to class of rating

In the determination of the rating:

For duty types S1 to S8, the specified value(s) of the constant load(s) shall be the rated output(s), see 4.2.1 to 4.2.8.

For duty types S9 and S10, the reference value of the load based on duty type S1 shall be taken as the rated output, see 4.2.9 and 4.2.10.

5.5 Rated output

5.5.1 DC generators

The rated output is the output at the terminals and shall be expressed in watts (W).

5.5.2 AC generators

The rated output is the apparent power at the terminals and shall be expressed in volt-amperes (VA) together with the power factor.

The rated power factor for synchronous generators shall be 0,8 lagging (over-excited), unless otherwise specified by the purchaser.

5.5.3 Motors

The rated output is the mechanical power available at the shaft and shall be expressed in watts (W).

NOTE It is the practice in some countries for the mechanical power available at the shafts of motors to be expressed in horsepower (1 h.p. is equivalent to 745,7 W; 1 ch (cheval or metric horsepower) is equivalent to 736 W).

5.5.4 Synchronous condensers

The rated output is the reactive power at the terminals and shall be expressed in volt-amperes reactive (var) in leading (under-excited) and lagging (over-excited) conditions.

5.6 Rated voltage

5.6.1 DC generators

For d.c. generators intended to operate over a relatively small range of voltage, the rated output and current shall apply at the highest voltage of the range, unless otherwise specified, see also 7.3.

5.6.2 AC generators

For a.c. generators intended to operate over a relatively small range of voltage, the rated output and power factor shall apply at any voltage within the range, unless otherwise specified, see also 7.3.

5.7 Co-ordination of voltages and outputs

It is not practical to build machines of all ratings for all rated voltages. In general, for a.c. machines, based on design and manufacturing considerations, preferred voltage ratings above 1 kV in terms of rated output are as shown in Table 1.

Table 1 – Preferred voltage ratings

Rated voltage kV	Minimum rated output kW (or kVA)
$1,0 < U_N \leq 3,0$	100
$3,0 < U_N \leq 6,0$	150
$6,0 < U_N \leq 11,0$	800
$11,0 < U_N \leq 15,0$	2 500

5.8 Machines with more than one rating

For machines with more than one rating, the machine shall comply with this standard in all respects at each rating.

For multi-speed motors, a rating shall be assigned for each speed.

When a rated quantity (output, voltage, speed, etc.) may assume several values or vary continuously within two limits, the rating shall be stated at these values or limits. This provision does not apply to voltage and frequency variations during operation as defined in 7.3 or to star-delta connections intended for starting.

6 Site operating conditions

6.1 General

Unless otherwise specified, machines shall be suitable for the following site operating conditions. For site operating conditions deviating from those values, corrections are given in Clause 8.

6.2 Altitude

The altitude shall not exceed 1 000 m above sea-level.

6.3 Maximum ambient air temperature

The ambient air temperature shall not exceed 40 °C.

6.4 Minimum ambient air temperature

The ambient air temperature shall not be less than –15 °C for any machine.

The ambient air temperature shall be not less than 0 °C for a machine with any of the following:

- a) rated output greater than 3 300 kW (or kVA) per 1 000 min⁻¹;
- b) rated output less than 600 W (or VA);
- c) a commutator;
- d) a sleeve bearing;
- e) water as a primary or secondary coolant.

6.5 Water coolant temperature

For the reference water coolant temperature see Table 4. For other water coolant temperatures see Table 9. The water coolant temperature shall not be less than +5 °C.

6.6 Storage and transport

When temperatures lower than specified in 6.4 are expected during transportation, storage, or after installation, the purchaser shall inform the manufacturer and specify the expected minimum temperature.

6.7 Purity of hydrogen coolant

Hydrogen cooled machines shall be capable of operating at rated output under rated conditions with a coolant containing not less than 95 % hydrogen by volume.

NOTE For safety reasons, the hydrogen content should at all times be maintained at 90 % or more, it being assumed that the other gas in the mixture is air.

For calculating efficiency in accordance with IEC 60034-2 (all parts), the standard composition of the gaseous mixture shall be 98 % hydrogen and 2 % air by volume, at the specified values of pressure and temperature of the re-cooled gas, unless otherwise agreed. Windage losses shall be calculated at the corresponding density.

7 Electrical operating conditions

7.1 Electrical supply

For three-phase a.c. machines, 50 Hz or 60 Hz, intended to be directly connected to distribution or utilisation systems, the rated voltages shall be derived from the nominal voltages given in IEC 60038.

NOTE For large high-voltage a.c. machines, the voltages may be selected for optimum performance.

For a.c. motors supplied from static converters these restrictions on voltage, frequency and waveform do not apply. In this case, the rated voltages shall be selected by agreement.

7.2 Form and symmetry of voltages and currents

7.2.1 AC motors

7.2.1.1 AC motors rated for use on a power supply of fixed frequency, supplied from an a.c. generator (whether local or via a supply network) shall be suitable for operation on a supply voltage having a harmonic voltage factor (*HVF*) not exceeding:

- 0,02 for single-phase motors and three-phase motors, including synchronous motors but excluding motors of design N (see IEC 60034-12), unless the manufacturer declares otherwise.
- 0,03 for design N motors.

The *HVF* shall be computed by using the following formula:

$$HVF = \sqrt{\sum_{n=2}^k \frac{u_n^2}{n}}$$

where

u_n is the ratio of the harmonic voltage U_n to the rated voltage U_N ;

n is the order of harmonic (not divisible by three in the case of three-phase a.c. motors);

$k = 13$.

Three-phase a.c. motors shall be suitable for operation on a three-phase voltage system having a negative-sequence component not exceeding 1 % of the positive-sequence

component over a long period, or 1,5 % for a short period not exceeding a few minutes, and a zero-sequence component not exceeding 1 % of the positive-sequence component.

Should the limiting values of the *HVF* and of the negative-sequence and zero-sequence components occur simultaneously in service at the rated load, this shall not lead to any harmful temperature in the motor and it is recommended that the resulting excess temperature rise related to the limits specified in this standard should be not more than approximately 10 K.

NOTE In the vicinity of large single-phase loads (e.g. induction furnaces), and in rural areas particularly on mixed industrial and domestic systems, supplies may be distorted beyond the limits set out above. Special arrangements will then be necessary.

7.2.1.2 AC motors supplied from static converters have to tolerate higher harmonic contents of the supply voltage; see IEC 60034-17 for the case of cage motors within the scope of IEC 60034-12.

NOTE When the supply voltage is significantly non-sinusoidal, for example from static converters, the r.m.s. value of the total waveform and of the fundamental are both relevant in determining the performance of an a.c. machine.

7.2.2 AC generators

Three-phase a.c. generators shall be suitable for supplying circuits which, when supplied by a system of balanced and sinusoidal voltages:

- a) result in currents not exceeding a harmonic current factor (*HCF*) of 0,05, and
- b) result in a system of currents where neither the negative-sequence component nor the zero-sequence component exceed 5 % of the positive-sequence component.

The *HCF* shall be computed by using the following formula:

$$HCF = \sqrt{\sum_{n=2}^k i_n^2}$$

where

i_n is the ratio of the harmonic current I_n to the rated current I_N ;

n is the order of harmonic;

$k = 13$.

Should the limits of deformation and imbalance occur simultaneously in service at the rated load, this shall not lead to any harmful temperature in the generator and it is recommended that the resulting excess temperature rise related to the limits specified in this standard should be not more than approximately 10 K.

7.2.3 Synchronous machines

Unless otherwise specified, three-phase synchronous machines shall be capable of operating continuously on an unbalanced system in such a way that, with none of the phase currents exceeding the rated current, the ratio of the negative-sequence component of current (I_2) to the rated current (I_N) does not exceed the values in Table 2 and under fault conditions shall be capable of operation with the product of $(I_2/I_N)^2$ and time (t) not exceeding the values in Table 2.

Table 2 – Unbalanced operating conditions for synchronous machines

Item	Machine type	Maximum I_2/I_N value for continuous operation	Maximum $(I_2/I_N)^2 \times t$ in seconds for operation under fault conditions
Salient pole machines			
1	Indirect cooled windings		
	motors	0,1	20
	generators	0,08	20
	synchronous condensers	0,1	20
2	Direct cooled (inner cooled) stator and/or field windings		
	motors	0,08	15
	generators	0,05	15
	synchronous condensers	0,08	15
Cylindrical rotor synchronous machines			
3	Indirect cooled rotor windings		
	air-cooled	0,1	15
	hydrogen-cooled	0,1	10
4	Direct cooled (inner cooled) rotor windings		
	≤350 MVA	0,08	8
	>350 ≤900 MVA	a	b
	>900 ≤1 250 MVA	a	5
	>1 250 ≤1 600 MVA	0,05	5
<p>^a For these machines, the value of I_2/I_N is calculated as follows:</p> $\frac{I_2}{I_N} = 0,08 - \frac{S_N - 350}{3 \times 10^4}$ <p>^b For these machines, the value of $(I_2/I_N)^2 \times t$, in seconds, is calculated as follows:</p> $(I_2/I_N)^2 \times t = 8 - 0,005\,45 (S_N - 350)$ <p>where in the two footnotes, S_N is the rated apparent power in MVA.</p>			

7.2.4 DC motors supplied from static power converters

In the case of a d.c. motor supplied from a static power converter, the pulsating voltage and current affect the performance of the machine. Losses and temperature rise will increase and the commutation is more difficult compared with a d.c. motor supplied from a pure d.c. power source.

It is necessary, therefore, for motors with a rated output exceeding 5 kW, intended for supply from a static power converter, to be designed for operation from a specified supply, and, if considered necessary by the motor manufacturer, for an external inductance to be provided for reducing the undulation.

The static power converter supply shall be characterized by means of an identification code, as follows:

$$[CCC - U_{aN} - f - L]$$

where

CCC is the identification code for converter connection according to IEC 60971;

- U_{aN} consists of three or four digits indicating the rated alternating voltage at the input terminals of the converter, in V;
- f consists of two digits indicating the rated input frequency, in Hz;
- L consists of one, two or three digits indicating the series inductance to be added externally to the motor armature circuit, in mH. If this is zero, it is omitted.

Motors with rated output not exceeding 5 kW, instead of being tied to a specific type of static power converter, may be designed for use with any static power converter, with or without external inductance, provided that the rated form factor for which the motor is designed will not be surpassed and that the insulation level of the motor armature circuit is appropriate for the rated alternating voltage at the input terminals of the static power converter.

In all cases, the undulation of the static power converter output current is assumed to be so low as to result in a current ripple factor not higher than 0,1 at rated conditions.

7.3 Voltage and frequency variations during operation

For a.c. machines rated for use on a power supply of fixed frequency supplied from an a.c. generator (whether local or via a supply network), combinations of voltage variation and frequency variation are classified as being either zone A or zone B, in accordance with Figure 11 for generators and synchronous condensers, and Figure 12 for motors.

For d.c. machines, when directly connected to a normally constant d.c. bus, zones A and B apply only to the voltages.

A machine shall be capable of performing its primary function, as specified in Table 3, continuously within zone A, but need not comply fully with its performance at rated voltage and frequency (see rating point in Figures 11 and 12), and may exhibit some deviations. Temperature rises may be higher than at rated voltage and frequency.

A machine shall be capable of performing its primary function within zone B, but may exhibit greater deviations from its performance at rated voltage and frequency than in zone A. Temperature rises may be higher than at rated voltage and frequency and most likely will be higher than those in zone A. Extended operation at the perimeter of zone B is not recommended.

NOTE 1 In practical applications and operating conditions, a machine will sometimes be required to operate outside the perimeter of zone A. Such excursions should be limited in value, duration and frequency of occurrence. Corrective measures should be taken, where practical, within a reasonable time, for example, a reduction in output. Such action may avoid a reduction in machine life from temperature effects.

NOTE 2 The temperature-rise limits or temperature limits in accordance with this standard apply at the rating point and may be progressively exceeded as the operating point moves away from the rating point. For conditions at the extreme boundaries of zone A, the temperature rises and temperatures typically exceed the limits specified in this standard by approximately 10 K.

NOTE 3 An a.c. motor will start at the lower limit of voltage only if its starting torque is adequately matched to the counter-torque of the load, but this is not a requirement of this clause. For starting performance of design N motors, see IEC 60034-12.

NOTE 4 For machines covered by IEC 60034-3, different voltage and frequency limits apply.

Table 3 – Primary functions of machines

Item	Machine type	Primary function
1	AC generator, excluding item 5	Rated apparent power (kVA), at rated power factor where this is separately controllable
2	AC motor, excluding items 3 and 5	Rated torque (Nm)
3	Synchronous motor, excluding item 5	Rated torque (Nm), the excitation maintaining either rated field current or rated power factor, where this is separately controllable
4	Synchronous condenser, excluding item 5	Rated apparent power (kVA) within the zone applicable to a generator, see Figure 11, unless otherwise agreed
5	Turbine-type machine, with rated output ≥ 10 MVA	See IEC 60034-3
6	DC generator	Rated output (kW)
7	DC motor	Rated torque (Nm), the excitation of a shunt motor maintaining rated speed, where this is separately controllable

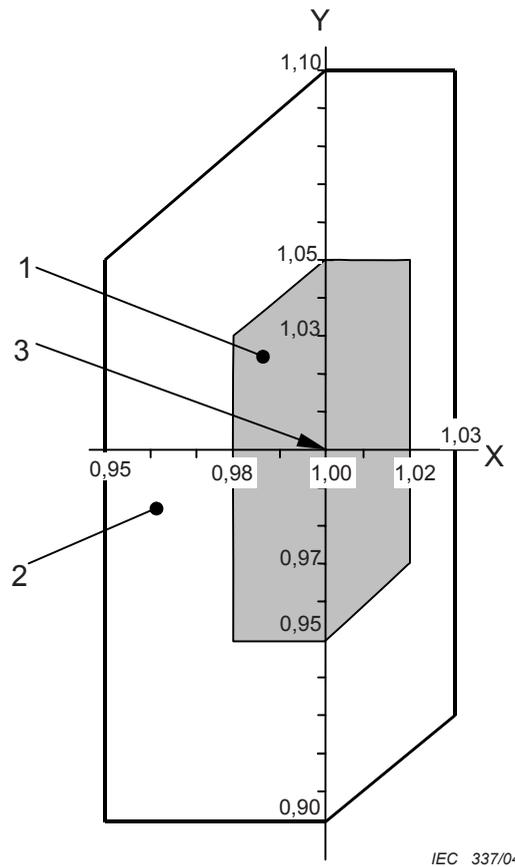
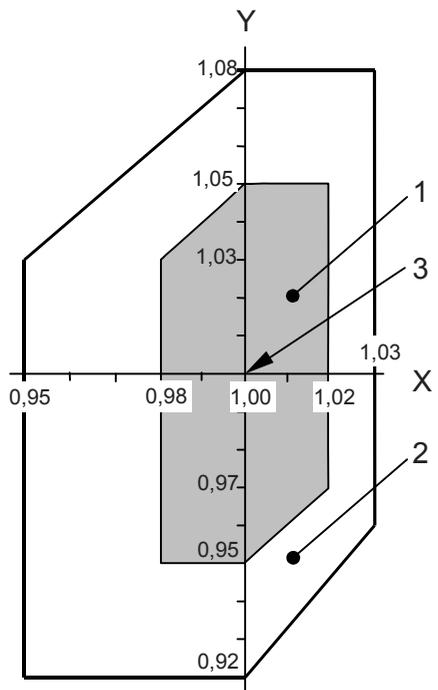

Key

X axis frequency p.u.
 Y axis voltage p.u.

- 1 zone A
- 2 zone B (outside zone A)
- 3 rating point

Figure 11 – Voltage and frequency limits for generators

Figure 12 – Voltage and frequency limits for motors

7.4 Three-phase a.c. machines operating on unearthed systems

Three-phase a.c. machines shall be suitable for continuous operation with the neutral at or near earth potential. They shall also be suitable for operation on unearthed systems with one line at earth potential for infrequent periods of short duration, for example as required for normal fault clearance. If it is intended to run the machine continuously or for prolonged periods in this condition, a machine with a level of insulation suitable for this condition will be required.

If the winding does not have the same insulation at the line and neutral ends, this shall be stated by the manufacturer.

NOTE The earthing or interconnection of the machine's neutral points should not be undertaken without consulting the machine manufacturer because of the danger of zero-sequence components of currents of all frequencies under some operating conditions and the risk of mechanical damage to the windings under line-to-neutral fault conditions.

7.5 Voltage (peak and gradient) withstand levels

For a.c. motors the manufacturer shall declare a limiting value for the peak voltage and for the voltage gradient in continuous operation.

For cage induction motors within the scope of IEC 60034-12, see also IEC 60034-17.

For high-voltage a.c. motors, see also IEC 60034-15.

For creepage and clearance distances of bare live copper, see IEC 60664-1.

8 Thermal performance and tests

8.1 Thermal class

A thermal class in accordance with IEC 60085 shall be assigned to the insulation systems used in machines.

It is the responsibility of the manufacturer of the machine to interpret the results obtained by thermal endurance testing according to the appropriate part of IEC 60034-18.

NOTE 1 The thermal class of a new insulation system should not be assumed to be directly related to the thermal capability of the individual materials used in it.

NOTE 2 The continued use of an existing insulation system is acceptable where it has been proved by satisfactory service experience.

8.2 Reference coolant

The reference coolant for a given method of cooling the machine is specified in Table 4.

Table 4 – Reference coolant (see also Table 10)

Item	Primary coolant	Method of cooling	Secondary coolant	Table number	Table referred to in column 5 specifies limits of:	Reference coolant
1	Air	Indirect	None	7	Temperature rise	Ambient air
2	Air	Indirect	Air	7		Reference temperature: 40 °C
3	Air	Indirect	Water	7		Coolant at inlet to machine or ambient water Reference temperature of cooling gas at inlet to machine: 40 °C Reference temperature of ambient water: 25 °C (see note)
4	Hydrogen	Indirect	Water	8		
5	Air	Direct	None	12	Temperature	Ambient air
6	Air	Direct	Air	12		Reference temperature: 40 °C
7	Air	Direct	Water	12		Gas at entry to machine or liquid at entry to the windings Reference temperature: 40 °C
8	Hydrogen or liquid	Direct	Water	12		

NOTE A machine with indirect cooled windings and a water cooled heat exchanger may be rated using either the primary or secondary coolant as the reference coolant (see also 10.2 for information to be given on the rating plate). A submersible machine with surface cooling or a machine with water jacket cooling should be rated using the secondary coolant as reference coolant.

If a third coolant is used, temperature rise shall be measured above the temperature of the primary or secondary coolant as specified in Table 4.

NOTE A machine may be so arranged and cooled that more than one item of Table 4 applies, in which case different reference coolants may apply for different windings.

8.3 Conditions for thermal tests

8.3.1 Electrical supply

During thermal testing of an a.c. motor the HVF of the supply shall not exceed 0,015 and the negative-sequence component of the system of voltages shall be less than 0,5 % of the positive-sequence component, the influence of the zero-sequence component being eliminated.

By agreement, the negative-sequence component of the system of currents may be measured instead of the negative-sequence component of the system of voltages. The negative-sequence component of the system of currents shall not exceed 2,5 % of the positive-sequence component.

8.3.2 Temperature of machine before test

If the temperature of a winding is to be determined from the increase of resistance, the initial winding temperature shall not differ from the coolant by more than 2 K.

When a machine is to be tested on a short-time rating (duty type S2) its temperature at the beginning of the thermal test shall be within 5 K of the temperature of the coolant.

8.3.3 Temperature of coolant

A machine may be tested at any convenient value of coolant temperature. See Table 11 (for indirect cooled windings) or Table 14 (for direct cooled windings).

8.3.4 Measurement of coolant temperature during test

The value to be adopted for the temperature of a coolant during a test shall be the mean of the readings of the temperature detectors taken at equal intervals of time during the last quarter of the duration of the test. To reduce errors due to the time lag of the change of temperature of large machines following variations in the temperature of the coolant, all reasonable precautions shall be taken to minimize such variations.

8.3.4.1 Open machines or closed machines without heat exchangers (cooled by surrounding ambient air or gas)

The temperature of the ambient air or gas shall be measured by means of several detectors placed at different points around and halfway up the machine at 1 m to 2 m from it. Each detector shall be protected from radiant heat and draughts.

8.3.4.2 Machines cooled by air or gas from a remote source through ventilation ducts and machines with separately mounted heat exchangers

The temperature of the primary coolant shall be measured where it enters the machine.

8.3.4.3 Closed machines with machine-mounted or internal heat exchangers

The temperature of the primary coolant shall be measured where it enters the machine. The temperature of the secondary coolant shall be measured where it enters the heat exchanger.

8.4 Temperature rise of a part of a machine

The temperature rise, $\Delta\theta$, of a part of a machine is the difference between the temperature of that part measured by the appropriate method in accordance with 8.5, and the temperature of the coolant measured in accordance with 8.3.4.

For comparison with the limits of temperature rise (see Table 7 or 8) or of temperature (see Table 12), when possible, the temperature shall be measured immediately before the machine is shut down at the end of the thermal test, as described in 8.7.

When this is not possible, for example, when using the direct measurement of resistance method, see 8.6.2.3.

For machines tested on actual periodic duty (duty types S3 to S8) the temperature at the end of the test shall be taken as that at the middle of the rise period causing the greatest heating in the last cycle of operation (but see also 8.7.3).

8.5 Methods of measurement of temperature

8.5.1 General

Three methods of measuring the temperature of windings and other parts are recognized:

- resistance method;
- embedded temperature detector (ETD) method;
- thermometer method.

Different methods shall not be used as a check upon one another.

For indirect testing see IEC 60034-29.

8.5.2 Resistance method

The temperature of the windings is determined from the increase of the resistance of the windings.

8.5.3 Embedded temperature detector (ETD) method

The temperature is determined by means of temperature detectors (e.g. resistance thermometers, thermocouples or semi-conductor negative coefficient detectors) built into the machine during construction, at points which are inaccessible after the machine is completed.

8.5.4 Thermometer method

The temperature is determined by thermometers applied to accessible surfaces of the completed machine. The term 'thermometer' includes not only bulb-thermometers, but also non-embedded thermocouples and resistance thermometers. When bulb-thermometers are used in places where there is a strong varying or moving magnetic field, alcohol thermometers shall be used in preference to mercury thermometers.

8.6 Determination of winding temperature

8.6.1 Choice of method

In general, for measuring the temperature of the windings of a machine, the resistance method in accordance with 8.5.1 shall be applied (but see also 8.6.2.3.3).

For a.c. stator windings of machines having a rated output of 5 000 kW (or kVA) or more the ETD method shall be used.

For a.c. machines having a rated output less than 5 000 kW (or kVA) but greater than 200 kW (or kVA) the manufacturer shall choose either the resistance or the ETD method, unless otherwise agreed.

For a.c. machines having a rated output less than or equal to 200 kW (or kVA) the manufacturer shall choose the direct measurement version or the superposition version of the resistance method (see 8.6.2.1), unless otherwise agreed (but see also below).

For machines having a rated output less than or equal to 600 W (or VA), when the windings are non-uniform or severe complications are involved in making the necessary connections, the temperature may be determined by means of thermometers. Temperature rise limits in accordance with Table 7, item 1d for resistance method shall apply.

The thermometer method is recognized in the following cases:

- a) when it is not practicable to determine the temperature rise by the resistance method as, for example, with low-resistance commutating coils and compensating windings and, in general, in the case of low-resistance windings, especially when the resistance of joints and connections forms a considerable proportion of the total resistance;
- b) single layer windings, rotating or stationary;
- c) during routine tests on machines manufactured in large numbers.

For a.c. stator windings having only one coil-side per slot, the ETD method shall not be used for verifying compliance with this standard: the resistance method shall be used.

NOTE For checking the temperature of such windings in service, an embedded detector at the bottom of the slot is of little value because it gives mainly the temperature of the iron core. A detector placed between the coil and the wedge will follow the temperature of the winding much more closely and is, therefore, better for checks in

service. Because the temperature there may be rather low, the relation between it and the temperature measured by the resistance method should be determined by a thermal test.

For other windings having one coil-side per slot and for end windings, the ETD method shall not be used for verifying compliance with this standard.

For windings of armatures having commutators and for field windings, the resistance method and the thermometer method are recognized. The resistance method is preferred, but for stationary field windings of d.c. machines having more than one layer the ETD method may be used.

8.6.2 Determination by resistance method

8.6.2.1 Measurement

One of the following methods shall be used:

- direct measurement at the beginning and the end of the test, using an instrument having a suitable range;
- measurement by d.c. current/voltage in d.c. windings, by measuring the current in and the voltage across the winding, using instruments having suitable ranges;
- measurement by d.c. current/voltage in a.c. windings, by injecting direct current into the winding when de-energized.

8.6.2.2 Calculation

The temperature rise, $\theta_2 - \theta_a$, may be obtained from the equation:

$$\frac{\theta_2 + k}{\theta_1 + k} = \frac{R_2}{R_1}$$

where

θ_1 is the temperature (°C) of the winding (cold) at the moment of the initial resistance measurement;

θ_2 is the temperature (°C) of the winding at the end of the thermal test;

θ_a is the temperature (°C) of the coolant at the end of the thermal test;

R_1 is the resistance of the winding at temperature θ_1 (cold);

R_2 is the resistance of the winding at the end of the thermal test;

k is the reciprocal of the temperature coefficient of resistance at 0 °C of the conductor material.

For copper $k = 235$

For aluminium $k = 225$ unless specified otherwise.

For practical purposes, the following alternative formula may be found convenient:

$$\theta_2 - \theta_a = \frac{R_2 - R_1}{R_1} \times (k + \theta_1) + \theta_1 - \theta_a$$

8.6.2.3 Correction for stopping time

8.6.2.3.1 General

The measurement of temperatures at the end of the thermal test by the direct measurement resistance method requires a quick shutdown. A carefully planned procedure and an adequate number of people are required.

8.6.2.3.2 Short stopping time

If the initial resistance reading is obtained within the time interval specified in Table 5, that reading shall be accepted for the temperature measurement.

Table 5 – Time interval

Rated output (P_N) kW or kVA	Time interval after switching off power s
$P_N \leq 50$	30
$50 < P_N \leq 200$	90
$200 < P_N \leq 5\,000$	120
$5\,000 < P_N$	By agreement

8.6.2.3.3 Extended stopping time

If a resistance reading cannot be made in the time interval specified in Table 5, it shall be made as soon as possible but not after more than twice the interval specified in Table 5, and additional readings shall be taken at intervals of approximately 1 min until these readings have begun a distinct decline from their maximum value. A curve of these readings shall be plotted as a function of time and extrapolated to the appropriate time interval of Table 5 for the rated output of the machine. A semi-logarithmic plot is recommended where temperature is plotted on the logarithmic scale. The value of temperature thus obtained shall be considered as the temperature at shutdown. If successive measurements show increasing temperatures after shutdown the highest value shall be taken.

If a resistance reading cannot be made until after twice the time interval specified in Table 5, this method of correction shall only be used by agreement.

8.6.2.3.4 Windings with one coil-side per slot

For machines with one coil-side per slot, the resistance method by direct measurement may be used if the machine comes to rest within the time interval specified in Table 5. If the machine takes more than 90 s to come to rest after switching off the power, the superposition method may be used if previously agreed.

8.6.3 Determination by ETD method

8.6.3.1 General

The detectors shall be suitably distributed throughout the winding and the number of detectors installed shall be not less than six.

All reasonable efforts, consistent with safety, shall be made to place the detectors at the points where the highest temperatures are likely to occur, in such a manner that they are effectively protected against contact with the primary coolant.

The highest reading from the ETD elements shall be used to determine the temperature of the winding.

NOTE ETD elements or their connections may fail and give incorrect readings. Therefore, if one or more readings are shown to be erratic, after investigation they should be eliminated.

8.6.3.2 Two or more coil-sides per slot

The detectors shall be located between the insulated coil-sides within the slot in positions at which the highest temperatures are likely to occur.

8.6.3.3 One coil-side per slot

The detectors shall be located between the wedge and the outside of the winding insulation in positions at which the highest temperatures are likely to occur, but see also 8.6.1.

8.6.3.4 End windings

The temperature detectors shall be located between two adjacent coil-sides within the end windings in positions where the highest temperatures are likely to occur. The sensing point of each detector shall be in close contact with the surface of a coil-side and be adequately protected against the influence of the coolant, but see also 8.6.1.

8.6.4 Determination by thermometer method

All reasonable efforts, consistent with safety, shall be made to place thermometers at the point, or points where the highest temperatures are likely to occur (e.g. in the end windings close to the core iron) in such a manner that they are effectively protected against contact with the primary coolant and are in good thermal contact with the winding or other part of the machine.

The highest reading from any thermometer shall be taken to be the temperature of the winding or other part of the machine.

8.7 Duration of thermal tests

8.7.1 Rating for continuous running duty

The test shall be continued until thermal equilibrium has been reached.

8.7.2 Rating for short-time duty

The duration of the test shall be the time given in the rating.

8.7.3 Rating for periodic duty

Normally the rating for equivalent loading assigned by the manufacturer (see 5.2.6) shall be applied until thermal equilibrium has been reached. If a test on the actual duty is agreed, the load cycle specified shall be applied and continued until practically identical temperature cycles are obtained. The criterion for this shall be that a straight line between the corresponding points of successive duty cycles on a temperature plot has a gradient of less than 2 K per hour. If necessary, measurements shall be taken at reasonable intervals over a period of time.

8.7.4 Ratings for non-periodic duty and for duty with discrete constant loads

The rating for equivalent loading assigned by the manufacturer (see 5.2.6) shall be applied until thermal equilibrium has been reached.

8.8 Determination of the thermal equivalent time constant for machines of duty type S9

The thermal equivalent time constant with ventilation as in normal operating conditions, suitable for approximate determination of the temperature course, can be determined from the cooling curve plotted in the same manner as in 8.6.2.3. The value of the time constant is

1,44 times (that is to say, $1/\ln(2)$ times) the time taken by the machine to cool to one-half of the full load temperature rise, after its disconnection from the supply.

8.9 Measurement of bearing temperature

Either the thermometer method or the ETD method may be used.

The measuring point shall be as near as possible to one of the two locations specified in Table 6.

Table 6 – Measuring points

Type of bearing	Measuring point	Location of measuring point
Ball or roller	A	In the bearing housing and not more than 10 mm ^a from the outer ring of the bearing ^b
	B	Outer surface of the bearing housing as close as possible to the outer ring of the bearing
Sleeve	A	In the pressure zone of the bearing shell ^c and not more than 10 mm ^a from the oil-film gap ^b .
	B	Elsewhere in the bearing shell

^a The distance is measured to the nearest point of the ETD or thermometer bulb.

^b In the case of an 'inside out' machine, point A will be in the stationary part not more than 10 mm from the inner ring and point B on the outer surface of the stationary part as close as possible to the inner ring.

^c The bearing shell is the part supporting the bearing material and which is secured in the housing. The pressure zone is the portion of the circumference which supports the combination of rotor weight and radial loads.

The thermal resistance between the temperature detector and the object whose temperature is to be measured shall be minimized; for example, air gaps shall be packed with thermally conducting paste.

NOTE Between the measuring points A and B, as well as between these points and the hottest point of the bearing, there are temperature differences which depend, among other things, on the bearing size. For sleeve bearings with pressed-in bushings and for ball and roller bearings with an inside diameter of up to 150 mm, the temperature difference between points A and B may be assumed to be negligible. In the case of larger bearings, the temperature difference between measuring points A and B is approximately 15 K.

8.10 Limits of temperature and of temperature rise

Limits are given for operation under site operating conditions specified in Clause 6 and at rating for continuous running duty (reference conditions), followed by rules for the adjustment of those limits when operating at site under other conditions and on other ratings. Further rules give adjustments to the limits during thermal testing when conditions at the test site differ from those at the operating site.

The limits are stated relative to the reference coolant specified in Table 4.

A rule is given to allow for the purity of hydrogen coolant.

8.10.1 Indirect cooled windings

Temperature rises under reference conditions shall not exceed the limits given in Table 7 (air coolant) or Table 8 (hydrogen coolant) as appropriate.

For other operating site conditions, for ratings other than continuous running duty, and for rated voltages greater than 12 000 V, the limits shall be adjusted according to Table 9. (See also Table 10 for limit on coolant temperature which is assumed in Table 9.)

In the case of thermometer readings made in accordance with 8.6.1, the limit of temperature rise shall be according to Table 7.

If, for windings indirectly cooled by air, conditions at the test site differ from those at the operating site, the adjusted limits given in Table 11 shall apply at the test site.

If the adjusted limits given in Table 11 lead to permissible temperatures at the test site which the manufacturer considers to be excessive, the testing procedure and the limits shall be agreed.

No adjustments at the test site are given for windings indirectly cooled by hydrogen, because it is very unlikely that they will be tested at rated load anywhere other than at the operating site.

Table 7 – Limits of temperature rise of windings indirectly cooled by air

Method of measurement		Thermal class			155 (F)			180 (H)		
		Th	R	ETD	Th	R	ETD	Th	R	ETD
Item	Part of machine	K	K	K	K	K	K	K	K	K
1a)	AC windings of machines having outputs of 5 000 kW (or kVA) or more	–	80	85 ^a	–	105	110 ^a	–	125	130 ^a
1b)	AC windings of machines having outputs above 200 kW (or kVA), but less than 5 000 kW (or kVA)	–	80	90 ^a	–	105	115 ^a	–	125	135 ^a
1c)	AC windings of machines having outputs of 200 kW (or kVA) or less, other than those in items 1d) or 1e) ^b	–	80	–	–	105	–	–	125	–
1d)	AC windings of machines having rated outputs of less than 600 W (or VA) ^b	–	85	–	–	110	–	–	130	–
1e)	AC windings which are self-cooled without a fan (IC 40) and/or with encapsulated windings ^b	–	85	–	–	110	–	–	130	–
2	Windings of armatures having commutators	70	80	–	85	105	–	105	125	–
3	Field windings of a.c. and d.c. machines other than those in item 4	70	80	–	85	105	–	105	125	–
4a)	Field windings of synchronous machines with cylindrical rotors having a d.c. excitation winding embedded in slots, except synchronous induction motors	–	90	–	–	110	–	–	135	–
4b)	Insulated stationary field windings of d.c. machines having more than one layer	70	80	90	85	105	110	105	125	135
4c)	Low-resistance field windings of a.c. and d.c. machines having more than one layer and compensating windings of d.c. machines	80	80	–	100	100	–	125	125	–
4d)	Single-layer windings of a.c. and d.c. machines with exposed bare or varnished metal surfaces ^c	90	90	–	110	110	–	135	135	–

a For adjustment for high-voltage a.c. windings, see item 4 of Table 9.

b With the application of the superposition test method to windings of machines rated at 200 kW (or kVA) or less with thermal classes 130 (B) and 155 (F), the limits of temperature rise given for the resistance method may be exceeded by 5 K.

c Also includes multiple layer windings, provided that the under layers are each in contact with the circulating primary coolant.

Table 8 – Limits of temperature rise of windings indirectly cooled by hydrogen

Thermal class		130 (B)		155 (F)	
Method of measurement		Resistance	ETD	Resistance	ETD
ETD = Embedded temperature detector		K	K	K	K
Item					
1	AC windings of machines having outputs of 5 000 kW (or kVA) or more or having a core length of 1 m or more Absolute hydrogen pressure ^{b)} ≤ 150 kPa (1,5 bar) > 150 kPa ≤ 200 kPa (2,0 bar) > 200 kPa ≤ 300 kPa (3,0 bar) > 300 kPa ≤ 400 kPa (4,0 bar) > 400 kPa	– – – – –	85 ^a 80 ^a 78 ^a 73 ^a 70 ^a	– – – – –	105 ^a 100 ^a 98 ^a 93 ^a 90 ^a
2a	AC windings of machines having outputs of less than 5 000 kW (or kVA), or having a core length of less than 1 m	80	85 ^a	100	110 ^a
2b	DC field windings of a.c. and d.c. machines other than those in items 3 and 4	80	–	105	–
3	DC field windings of machines having cylindrical rotors	85	–	105	–
4a	Low-resistance field windings of more than one layer and compensating windings	80	–	100	–
4b	Single-layer windings with exposed bare or varnished metal surfaces ^c	90	–	110	–
^a For adjustment for high-voltage a.c. windings see item 4 of Table 9. ^b This is the only item where the limit of temperature rise is dependant on hydrogen pressure. ^c Also includes multi-layer field windings provided that the under layers are each in contact with the circulating primary coolant.					

Table 9 – Adjustments to limits of temperature rise at the operating site of indirect cooled windings to take account of non-reference operating conditions and ratings

Item	Operation conditions or rating		Adjustment to limit of temperature rise ($\Delta\theta$) in Tables 7 and 8
1a	Maximum temperature of ambient air or of the cooling gas at inlet to the machine (θ_c) and for altitudes of up to 1 000 m. If the difference between the thermal class and the observable limit of temperature, consisting of the sum of the reference cold coolant inlet temperature of 40 °C and the limit of temperature rise according to Tables 7 and 8 is less or equal to 5 K: For a higher altitude replace 40 °C with the value given in Table 10.	$0\text{ °C} \leq \theta_c \leq 40\text{ °C}$	Increased by the amount by which the coolant temperature is less than 40 °C.

Table 9 (continued)

Item	Operation conditions or rating		Adjustment to limit of temperature rise ($\Delta\theta$) in Tables 7 and 8
1b	Maximum temperature of ambient air or of the cooling gas at the inlet to the machine (θ_c) and for altitudes of up to 1000 m. If the difference between the thermal class and the observable limit of the temperature, consisting of the sum of the reference cold coolant inlet temperature of 40 °C and the limit of temperature rise according to Tables 7 and 8 is larger than 5 K: For a higher altitude replace 40 °C with the value given in Table 10.	$0\text{ °C} \leq \theta_c \leq 40\text{ °C}$	Increased by the amount by which the coolant temperature is less than 40 °C, but this amount is reduced by the factor $\left(1 - \frac{\text{thermal class} - (40\text{ °C} + \text{lim.tmp.})}{80\text{ K}}\right)$ with <i>lim.tmp.</i> = limit of temperature rise according to Tables 7 or 8 at 40 °C cold coolant temperature
1c		$40\text{ °C} < \theta_c \leq 60\text{ °C}$	Reduced by the amount by which the coolant temperature exceeds 40 °C
1d		$\theta_c < 0\text{ °C}$ or $\theta_c > 60\text{ °C}$	By agreement
2	Maximum temperature of the water at the inlet to water-cooled heat exchangers or maximum temperature of the ambient water for submersible machines with surface cooling or machines with water jacket cooling (θ_w)	$5\text{ °C} \leq \theta_w \leq 25\text{ °C}$ $\theta_w > 25\text{ °C}$	Increased by 15 K and by the difference between 25 °C and θ_w Increased by 15 K and reduced by the difference between θ_w and 25 °C
3a	Altitude (<i>H</i>) - general rule	$1\ 000\text{ m} < H \leq 4\ 000\text{ m}$ and maximum ambient air temperature not specified $H > 4\ 000\text{ m}$	No adjustment. It shall be assumed that the reduced cooling resulting from altitude is compensated by a reduction of maximum ambient temperature below 40 °C and that the total temperature will therefore not exceed 40 °C plus the Table 7 and 8 temperature rises ^a By agreement
3b	Altitude (<i>H</i>) - power plant generator specific	according specification of the purchaser	The capability of power plant generators should be adjusted and is a function of the altitude (air pressure). No adjustment of the capability is needed for power plant generators if the absolute coolant pressure is maintained constant regardless of the altitude.
4	Rated stator winding voltage (U_N)	$12\text{ kV} < U_N \leq 24\text{ kV}$ $U_N > 24\text{ kV}$	$\Delta\theta$ for embedded temperature detectors (ETD) shall be reduced by 1 K for each 1 kV (or part thereof) from 12 kV up to and including 24 kV By agreement
5 ^b	Rating for short-time duty (S2), with rated output less than 5 000 kW (kVA)		Increased by 10 K
6 ^b	Rating for non-periodic duty (S9)		$\Delta\theta$ may be exceeded for short periods during the operation of the machine
7 ^b	Rating for duty with discrete loads (S10)		$\Delta\theta$ may be exceeded for discrete periods during the operation of the machine
^a Assuming the decrease in ambient temperature is 1 % of the limiting rises for every 100 m of altitude above 1 000 m, the maximum ambient air temperature at the operating site can be as shown in Table 10.			
^b For air-cooled windings only.			

Table 10 – Assumed maximum ambient temperature

Altitude m	Thermal class		
	130 (B)	155 (F)	180 (H)
	Temperature °C		
1 000	40	40	40
2 000	32	30	28
3 000	24	19	15
4 000	16	9	3

8.10.2 Direct cooled windings

Temperatures under reference conditions shall not exceed the limits given in Table 12.

For other operating site conditions the limits shall be adjusted according to Table 13.

If conditions at the test site differ from those at the operating site, the adjusted limits given in Table 14 shall apply at the test site.

If the adjusted limits given in Table 14 lead to temperatures at the test site which the manufacturer considers to be excessive, the testing procedure and the limits shall be agreed.

8.10.3 Adjustments to take account of hydrogen purity on test

For windings directly or indirectly cooled by hydrogen, no adjustment shall be made to limits of temperature rise or of total temperature if the proportion of hydrogen in the coolant is between 95 % and 100 %.

8.10.4 Permanently short-circuited windings, magnetic cores and all structural components (other than bearings) whether or not in contact with insulation

The temperature rise or the temperature shall not be detrimental to the insulation of that part or to any other part adjacent to it.

8.10.5 Commutators and sliprings, open or enclosed and their brushes and brushgear

The temperature rise or temperature of any commutator, slipring, brush or brushgear shall not be detrimental to the insulation of that part or any adjacent part.

The temperature rise or temperature of a commutator or slipring shall not exceed that at which the combination of brush grade and commutator or slipring material can handle the current over the full operating range.

Table 11 – Adjusted limits of temperature rise at the test site ($\Delta\theta_T$) for windings indirectly cooled by air to take account of test site operating conditions

Item	Test condition		Adjusted limit at test site $\Delta\theta_T$
1	Temperature difference of reference coolant at test site (θ_{cT}) and operating site (θ_c)	Absolute value of $(\theta_c - \theta_{cT}) \leq 30$ K	$\Delta\theta_T = \Delta\theta$
		Absolute value of $(\theta_c - \theta_{cT}) > 30$ K	By agreement
2	Difference of altitudes of test site (H_T) and operating site (H)	$1\ 000\text{ m} < H \leq 4\ 000\text{ m}$ $H_T < 1\ 000\text{ m}$	$\Delta\theta_T = \Delta\theta \left(1 - \frac{H - 1\ 000\text{ m}}{10\ 000\text{ m}} \right)$
		$H < 1\ 000\text{ m}$ $1\ 000\text{ m} < H_T \leq 4\ 000\text{ m}$	$\Delta\theta_T = \Delta\theta \left(1 + \frac{H_T - 1\ 000\text{ m}}{10\ 000\text{ m}} \right)$
		$1\ 000\text{ m} < H \leq 4\ 000\text{ m}$ $1\ 000\text{ m} < H_T \leq 4\ 000\text{ m}$	$\Delta\theta_T = \Delta\theta \left(1 + \frac{H_T - H}{10\ 000\text{ m}} \right)$
		$H > 4\ 000\text{ m}$ or $H_T > 4\ 000\text{ m}$	By agreement
NOTE 1 $\Delta\theta$ is given in Table 7 and adjusted if necessary in accordance with Table 9.			
NOTE 2 If temperature rise is to be measured above the temperature of the water where it enters the cooler, the effect of altitude on the temperature difference between air and water should strictly be allowed for. However, for most cooler designs, the effect will be small, the difference increasing with increasing altitude at the rate of roughly 2 K per 1 000 m. If an adjustment is necessary, it should be by agreement.			

Table 12 – Limits of temperature of directly cooled windings and their coolants

Thermal class		130 (B)			155 (F)		
Method of measurement		Thermo- meter °C	Resistance °C	ETD °C	Thermo- meter °C	Resistance °C	ETD °C
Item	Part of the machine						
1	Coolant at the outlet of direct-cooled a.c. windings. These temperatures are preferred to the values given in item 2 as the basis of rating.						
1a)	Gas (air, hydrogen, helium, etc.)	110	–	–	130	–	–
1b)	Water	90	–	–	90	–	–
2	AC windings						
2a)	Gas cooled	–	–	120 ^a	–	–	145 ^a
2b)	Liquid cooled						
3	Field windings of turbine type machines						
3a)	Cooled by gas leaving the rotor through the following number of outlet regions ^b						
	1 and 2	–	100	–	–	115	–
	3 and 4	–	105	–	–	120	–
	5 and 6	–	110	–	–	125	–
	7 to 14	–	115	–	–	130	–
	above 14	–	120	–	–	135	–
3b)	Liquid cooled	Observance of the maximum coolant temperature given in item 1b) will ensure that the hotspot temperature of the winding is not excessive					
4	Field windings of a.c. and d.c. machines having d.c. excitation other than in item 3.						
4a)	Gas cooled	–	130	–	–	150	–
4b)	Liquid cooled	Observance of the maximum coolant temperature given in item 1b) will ensure that the hotspot temperature of the winding is not excessive					
^a	No adjustment in the case of high-voltage a.c. windings is applicable to these items, see Table 13, item 2.						
^b	The rotor ventilation is classified by the number of radial outlet regions on the total length of the rotor. Special outlet regions for the coolant of the end windings are included as one outlet for each end. The common outlet region of two axially opposed flows is to be counted as two regions.						

Table 13 – Adjustments to limits of temperature at the operating site for windings directly cooled by air or hydrogen to take account of non-reference operating conditions and ratings

Item	Operating condition or rating		Adjustment to limit of temperature in Table 12
1	Temperature θ_c of reference coolant	$0\text{ }^\circ\text{C} \leq \theta_c \leq 40\text{ }^\circ\text{C}$	Reduction by the amount of the difference between $40\text{ }^\circ\text{C}$ and θ_c . However, by agreement, a smaller reduction may be applied, provided that for $\theta_c < 10\text{ }^\circ\text{C}$ the reduction is made at least equal to the difference between $10\text{ }^\circ\text{C}$ and θ_c .
		$40\text{ }^\circ\text{C} < \theta_c \leq 60\text{ }^\circ\text{C}$	No adjustment
		$\theta_c < 0\text{ }^\circ\text{C}$ or $\theta_c > 60\text{ }^\circ\text{C}$	By agreement
2	Rated stator winding voltage (U_N)	$U_N > 11\text{ kV}$	No adjustment The heat flow is mainly towards the coolant inside the conductors and not through the main insulation of the winding.

Table 14 – Adjusted limits of temperature at the test site θ_T for windings directly cooled by air to take account of test site operating conditions

Item	Test condition		Adjusted limit of temperature at test site θ_T
1	Difference of reference coolant temperatures of test site (θ_{cT}) and operating site (θ_c)	Absolute value of $(\theta_c - \theta_{cT}) \leq 30\text{ K}$	$\theta_T = \theta$
		Absolute value of $(\theta_c - \theta_{cT}) > 30\text{ K}$	By agreement
2	Difference of altitudes of test site (H_T) and operating site (H)	$1\ 000\text{ m} < H \leq 4\ 000\text{ m}$ $H_T < 1\ 000\text{ m}$	$\theta_T = (\theta - \theta_c) \left(1 - \frac{H - 1000\text{ m}}{10\ 000\text{ m}} \right) + \theta_{cT}$
		$H < 1\ 000\text{ m}$ $1\ 000\text{ m} < H_T \leq 4\ 000\text{ m}$	$\theta_T = (\theta - \theta_c) \left(1 + \frac{H_T - 1000\text{ m}}{10\ 000\text{ m}} \right) + \theta_{cT}$
		$1\ 000\text{ m} < H \leq 4\ 000\text{ m}$ $1\ 000\text{ m} < H_T \leq 4\ 000\text{ m}$	$\theta_T = (\theta - \theta_c) \left(1 + \frac{H_T - H}{10\ 000\text{ m}} \right) + \theta_{cT}$
		$H > 4\ 000\text{ m}$ or $H_T > 4\ 000\text{ m}$	By agreement
NOTE θ is given in Table 12 and adjusted if necessary in accordance with Table 13.			

9 Other performance and tests

9.1 Routine tests

Routine tests are always factory tests. They can only be performed on machines which are assembled at the works of the manufacturer. The machine need not be completely assembled. It can lack components which are not significant for the testing. Routine tests do not need the machine to be coupled except for the open-circuit test on synchronous machines.

The minimum test schedule is listed in Table 15 and is applicable for machines with rated output $\leq 20\text{ MW}$ (MVA). Additional routine tests may be performed especially on machines

with ratings above 200 kW (kVA). The term synchronous machines includes permanent magnet machines.

For d.c. machines, depending on size and design, a commutation test under load may be performed as a routine test.

Table 15 – Minimum schedule of routine tests

Number	Test	Induction machines (including synchronous induction motors) ^a	Synchronous machines		DC machines with separate or shunt excitation
			Motors	Generators	
1	Resistance of windings (cold)	Yes	Yes		Yes
2	No-load losses and current	Yes	–		–
3a	No-load losses at unity power factor ^b	–	Yes ^d		–
3b	No-load excitation current at rated voltage by open-circuit test ^b	–	Yes ^d		–
4	Excitation current at rated speed and rated armature voltage	–	–		Yes
5	Open circuit secondary induced voltage at standstill (wound rotor) ^c	Yes	–		–
6a	Direction of rotation	Yes	Yes	–	Yes
6b	Phase sequence	–	–	Yes	–
7	Withstand voltage test according to 9.2	Yes	Yes		Yes

^a IEC 411-33-04.
^b Permanent magnet machines excluded.
^c For safety considerations this test may be performed at reduced voltage.
^d Tests 3a and 3b are exclusive. Only one of these tests is required.

9.2 Withstand voltage test

A test voltage, as specified below, shall be applied between the windings under test and the frame of the machine, with the core and the windings not under test connected to the frame. It shall be applied only to a new and completed machine with all its parts in place under conditions equivalent to normal working conditions and shall be carried out at the manufacturer's works or after erection on site. When a thermal test is carried out, the withstand voltage test shall be carried out immediately after that test.

In the case of polyphase machines with rated voltage above 1 kV having both ends of each phase individually accessible, the test voltage shall be applied between each phase and the frame, with the core and the other phases and windings not under test connected to the frame.

Except as stated below, the test voltage shall be of power frequency and as near as possible to a sine wave form. The final value of the voltage shall be in accordance with Table 16. However, for machines with a rated voltage 6 kV or greater, when power frequency equipment is not available, then by agreement a d.c. test may be carried out at a voltage 1,7 times the r.m.s. value given in Table 16.

NOTE It is recognized that, during a d.c. test, the surface potential distribution along the end winding insulation and the ageing mechanisms are different from those occurring during an a.c. test.

The test shall be commenced at a voltage not exceeding half of the full test voltage. The voltage shall then be increased to the full value, steadily or in steps of not more than 5 % of

the full value, the time allowed for the voltage increase from half to full value being not less than 10 s. The full test voltage shall then be maintained for 1 min in accordance with the value as specified in Table 16. There shall be no failure (see IEC 60060-1) during this period.

During the routine testing of quantity produced machines up to 200 kW (or kVA) and rated for $U_N \leq 1$ kV, the 1 min test may be replaced by a test of 1 s at 120 % of the test voltage specified in Table 16.

The withstand voltage test at full voltage made on the windings on acceptance shall not be repeated. If, however, a second test is made at the request of the purchaser, after further drying if considered necessary, the test voltage shall be 80 % of the voltage specified in Table 16.

To determine the test voltage from Table 16 for d.c. motors supplied by static power converters, the direct voltage of the motor or the r.m.s. phase-to-phase value of the rated alternating voltage at the input terminals of the static power converter shall be used, whichever is the greater.

Completely rewound windings shall be tested at the full test voltage for new machines.

When a user and a repair contractor have agreed to carry out withstand voltage tests in cases where windings have been partially rewound or in the case of an overhauled machine, the following procedure is recommended:

- a) partially rewound windings are tested at 75 % of the test voltage for a new machine. Before the test, the old part of the winding shall be carefully cleaned and dried;
- b) overhauled machines, after cleaning and drying, are subjected to a test at a voltage equal to 1,5 times the rated voltage, with a minimum of 1 000 V if the rated voltage is equal to or greater than 100 V and a minimum of 500 V if the rated voltage is less than 100 V.

Table 16 – Withstand voltage tests

Item	Machine or part	Test voltage (r.m.s.)
1	Insulated windings of rotating machines of rated output less than 1 kW (or kVA) and of rated voltage less than 100 V with the exception of those in items 4 to 8	500 V + twice the rated voltage
2	Insulated windings of rotating machines of rated output less than 10 000 kW (or kVA) with the exception of those in item 1 and items 4 to 8 ^b	1 000 V + twice the rated voltage with a minimum of 1 500 V ^a
3	Insulated windings of rotating machines of rated output 10 000 kW (or kVA) or more with the exception of those in items 4 to 8 ^b Rated voltage ^a : - up to and including 24 000 V - above 24 000 V	1 000 V + twice the rated voltage Subject to agreement
4	Separately excited field windings of d.c. machines	1 000 V + twice the maximum rated circuit voltage with a minimum of 1 500 V
5	Field windings of synchronous generators, synchronous motors and synchronous condensers.	
5a)	Rated field voltage: - up to, and including 500 V, - above 500 V.	Ten times the rated field voltage with a minimum of 1 500 V 4 000 V + twice the rated field voltage

Table 16 (continued)

Item	Machine or part	Test voltage (r.m.s.)
5b)	When a machine is intended to be started with the field winding short-circuited or connected across a resistance of value less than ten times the resistance of the winding	Ten times the rated field voltage with a minimum of 1 500 V and a maximum of 3 500 V.
5c)	When the machine is intended to be started either with the field winding connected across a resistance of value equal to, or more than, ten times the resistance of the winding, or with the field windings on open circuit with or without a field-dividing switch	1 000 V + twice the maximum value of the r.m.s. voltage, which can occur under the specified starting conditions, between the terminals of the field winding, or in the case of a sectionalized field winding between the terminals of any section, with a minimum of 1 500 V ^c
6	Secondary (usually rotor) windings of induction motors or synchronous induction motors if not permanently short-circuited (e.g. if intended for rheostatic starting)	
6a)	For non-reversing motors or motors reversible from standstill only	1 000 V + twice the open-circuit standstill voltage as measured between slip-rings or secondary terminals with rated voltage applied to the primary windings
6b)	For motors to be reversed or braked by reversing the primary supply while the motor is running	1 000 V + four times the open-circuit standstill secondary voltage as defined in item 6a)
7	Exciters (except as below)	As for the windings to which they are connected
	<i>Exception 1:</i> exciters of synchronous motors (including synchronous induction motors) if connected to earth or disconnected from the field windings during starting	1 000 V + twice the rated exciter voltage, with a minimum of 1 500 V
	<i>Exception 2:</i> separately excited field windings of exciters (see item 4)	
8	Electrically interconnected machines and apparatus	A repetition of the tests in items 1 to 7 above should be avoided if possible, but if a test is performed on a group of machines and apparatus, each having previously passed its withstand voltage test, the test voltage to be applied to such an electrically connected arrangement shall be 80 % of the lowest test voltage appropriate for any individual piece of the arrangement ^d
9	Devices that are in physical contact with windings, for example, temperature detectors, shall be tested to the machine frame. During the withstand test on the machine, all devices in physical contact with the winding shall be connected to the machine frame.	1 500 V
a	For two-phase windings having one terminal in common, the voltage in the formula shall be the highest r.m.s. voltage arising between any two terminals during operation.	
b	Withstand tests on machines having graded insulation should be the subject of agreement.	
c	The voltage occurring between the terminals of the field windings, or sections thereof, under the specified starting conditions, may be measured at any convenient reduced supply voltage, and the voltage so measured shall be increased in the ratio of the specified starting supply voltage to the test supply voltage.	
d	For windings of one or more machines connected together electrically, the voltage to be considered is the maximum voltage that occurs in relation to earth.	

9.3 Occasional excess current

9.3.1 General

The excess current capability of rotating machines is given for the purpose of co-ordinating these machines with control and protective devices. Tests to demonstrate these capabilities are not a requirement of this standard. The heating effect in the machine windings varies approximately as the product of the time and the square of the current. A current in excess of

the rated current will result in increased temperature. Unless otherwise agreed, it can be assumed that the machine will not be operated at the excess currents specified for more than a few short periods during the lifetime of the machine. When an a.c. machine is to be used as both a generator and a motor, the excess current capability should be the subject of agreement.

NOTE For the capability of synchronous machines concerning the occasional negative-sequence component of current under fault conditions, see 7.2.3.

9.3.2 Generators

AC generators having rated outputs not exceeding 1 200 MVA shall be capable of withstanding a current equal to 1,5 times the rated current for not less than 30 s.

AC generators having rated outputs above 1 200 MVA shall be capable of withstanding a current equal to 1,5 times the rated current for a period which shall be agreed, but this period shall be not less than 15 s.

9.3.3 Motors (except commutator motors and permanent magnet motors)

Polyphase motors having rated outputs not exceeding 315 kW and rated voltages not exceeding 1 kV shall be capable of withstanding:

- a current equal to 1,5 times the rated current for not less than 2 min.

NOTE Polyphase motors having rated outputs above 315 kW and all single-phase motors, no occasional excess current is specified.

9.3.4 Commutator machines

A commutator machine shall be capable of withstanding, for 60 s, 1,5 times rated current under the appropriate combination of conditions as follows:

a) speed:

- 1) d.c. motor: highest full-field speed;
- 2) d.c. generator: rated speed;
- 3) a.c. commutator motor: highest full-field speed;

b) armature voltage: that corresponding to the specified speed.

NOTE Attention should be given to the limits of commutation capability.

9.4 Momentary excess torque for motors

9.4.1 Polyphase induction motors and d.c. motors

Motors, whatever their duty and construction, shall be capable of withstanding an excess torque of at least 60 % of their rated torque for 15 s without either stalling or exhibiting an abrupt change of speed (under gradual increase of torque). The voltage and frequency (for induction motors) shall be maintained at their rated values.

NOTE Higher torques are required for some motors manufactured according to IEC 60034-12.

For d.c. motors, the torque shall be expressed in terms of overload current.

Motors for duty type S9 shall be capable of withstanding momentarily an excess torque determined according to the duty specified.

NOTE For an approximate determination of the change in temperature due to the current-related losses, the thermal equivalent time constant determined according to 8.8 may be used.

Motors intended for specific applications that require a high torque (for example for hoisting) shall be the subject of agreement.

For cage-type induction motors specially designed to ensure a starting current of less than 4,5 times the rated current, the excess torque can be below the value of 60 % given in paragraph 1, but not less than 50 %.

In the case of special types of induction motors with special inherent starting properties, for example motors intended for use at variable frequency or induction motors supplied from static converters, the value of the excess torque shall be the subject of agreement.

9.4.2 Polyphase synchronous motors

Unless otherwise agreed, a polyphase synchronous motor, irrespective of the duty, shall be capable of withstanding an excess torque as specified below for 15 s without falling out of synchronism, the excitation being maintained at the value corresponding to rated load. When automatic excitation is used, the limits of torque shall be the same values with the excitation equipment operating under normal conditions:

- synchronous (wound rotor) induction motors: 35 % excess torque;
- synchronous (cylindrical rotor) motors: 35 % excess torque;
- synchronous (salient pole) motors: 50 % excess torque.

9.4.3 Other motors

The momentary excess torque for single-phase, commutator and other motors shall be the subject of agreement.

9.5 Pull-up torque

Unless otherwise specified (for example machines according to IEC 60034-12), the pull-up torque of cage induction motors under full voltage shall be not less than 0,3 times the rated torque.

9.6 Safe operating speed of cage induction motors

All three-phase single-speed cage induction motors of frame number up to and including 315 and for voltages up to and including 1 000 V shall be capable of safe continuous operation at speeds up to the appropriate speed given in Table 17 unless otherwise stated on the rating plate.

Table 17 – Maximum safe operating speed (min^{-1}) of three-phase single-speed cage induction motors for voltages up to and including 1 000 V

Frame number	2 pole	4 pole	6 pole
≤ 100	5 200	3 600	2 400
112	5 200	3 600	2 400
132	4 500	2 700	2 400
160	4 500	2 700	2 400
180	4 500	2 700	2 400
200	4 500	2 300	1 800
225	3 600	2 300	1 800
250	3 600	2 300	1 800
280	3 600	2 300	1 800
315	3 600	2 300	1 800

NOTE The above values may have to be reduced to meet the requirements of IEC 60079 [8].

NOTE When operating at speeds above rated speed, for example, when used with adjustable speed controls, noise and vibration levels will increase. The user may require to fine balance the motor rotor for acceptable operation above rated speed. Bearing life may be reduced. Attention should be paid to the re-greasing intervals and the grease service life.

9.7 Overspeed

Machines shall be designed to withstand the speeds specified in Table 18.

An overspeed test is not normally considered necessary but can be performed when this is specified and has been agreed. (For turbine-type a.c. generators, see also IEC 60034-3.) An overspeed test shall be considered as satisfactory if no permanent abnormal deformation is apparent subsequently, and no other weakness is detected which would prevent the machine from operating normally, and provided the rotor windings after the test comply with the required dielectric tests. The duration of any overspeed test shall be 2 min.

Due to settling of laminated rotor rims, laminated poles held by wedges or by bolts, etc. a minute permanent increase in the diameter is natural, and not to be considered as an abnormal deformation indicating that the machine is not suitable for normal operation.

During commissioning of a hydraulic-turbine driven synchronous generator, the machine shall be driven at the speed it can reach with the overspeed protection operating, so as to ascertain that the balance is satisfactory up to that speed.

Table 18 – Overspeeds

Item	Machine type	Overspeed
1	AC machines All machines other than those specified below:	1,2 times the maximum rated speed
1a)	Water-turbine driven generators, and any auxiliary machines connected directly (electrically or mechanically) to the main machine	Unless otherwise specified, the runaway speed of the set but not less than 1,2 times the maximum rated speed
1b)	Machines which may under certain circumstances be driven by the load	The specified runaway speed of the set but not less than 1,2 times the maximum rated speed.
1c)	Series and universal motors	1,1 times the no-load speed at rated voltage. For motors integrally attached to loads that cannot become accidentally disconnected, the words 'no-load speed' shall be interpreted to mean the lightest load condition possible with the load
1d)	Three-phase single-speed cage induction motors according to 9.6	1,2 times the maximum safe operating speed
2	DC machines	
2a)	Shunt and separately excited motor	1,2 times the highest rated speed or 1,15 times the corresponding no-load speed, whichever is greater
2b)	Compound excited motors having speed regulation of 35 % or less	1,2 times the higher rated speed or 1,15 times the corresponding no-load speed, whichever is greater but not exceeding 1,5 times the highest rated speed
2c)	Compound excited motors having speed regulation greater than 35 % and series motors	The manufacturer shall assign a maximum safe operating speed which shall be marked on the rating plate. The overspeed for these motors shall be 1,1 times the maximum safe operating speed. The safe operating speed marking is not required on motors that are capable of an overspeed of 1,1 times the no-load speed at rated voltage
2d)	Permanent-magnet excited motors	Overspeed as specified in item 2a) unless the motor has a series winding and, in such a case, they shall withstand the overspeeds specified in items 2b) or 2c) as appropriate
2e)	Generators	1,2 times the rated speed

9.8 Short-circuit current for synchronous machines

Unless otherwise specified, the peak value of the short-circuit current for synchronous machines, including turbine-type machines not covered by IEC 60034-3, in the case of short circuit on all phases during operation at rated voltage, shall not exceed 15 times the peak value or 21 times the r.m.s. value of the rated current.

Verification may be carried out by calculation or by means of a test at a voltage of 0,5 times the rated voltage or above.

9.9 Short-circuit withstand test for synchronous machines

The three-phase short-circuit test for synchronous machines shall be carried out only at the request of the purchaser. In this case, the test shall be carried out on the machine running on no-load with an excitation corresponding to the rated voltage unless otherwise agreed. The test shall not be carried out with an excitation greater than that corresponding to 1,05 times the rated voltage at no load.

The test excitation, as determined, may be reduced by agreement, in order to take into account the impedance of the transformer which may be placed between the machines and the system. In this latter case, it may also be agreed that the test be made at the operating site with the over-excitation device in operation. The short circuit shall be maintained for 3 s.

The test is considered satisfactory if no harmful deformation occurs and if the requirements of the applied voltage dielectric test (see Table 16) are met after the short-circuit test. For three-phase turbine-type machines, see IEC 60034-3.

9.10 Commutation test for commutator machines

A d.c. or a.c. commutator machine shall be capable of operating from no-load to operation with the excess current or excess torque, specified in 9.3 and 9.4 respectively, without permanent damage to the surface of the commutator or brushes and without injurious sparking, the brushes remaining in the same set position. If possible, the commutation test shall be performed in warm conditions.

9.11 Total harmonic distortion (*THD*) for synchronous machines

9.11.1 General

The requirements of this subclause apply only to synchronous machines having rated outputs of 300 kW (or kVA) or more, intended for connection to power networks operating at nominal frequencies of 16^{2/3} Hz to 100 Hz inclusive, with a view to minimizing interference caused by the machines.

9.11.2 Limits

When tested on open-circuit and at rated speed and voltage, the total harmonic distortion (*THD*) of the line-to-line terminal voltage, as measured according to the methods laid down in 9.11.3, shall not exceed 5 %.

NOTE Limiting values of individual harmonics are not specified as it is considered that machines which meet the above requirements will operate satisfactory.

9.11.3 Tests

Type tests shall be carried out on a.c. machines to verify compliance with 9.11.2. The range of frequencies measured shall cover all harmonics from rated frequency up to the 100th harmonic.

Either the *THD* may be measured directly by means of a meter and associated network specially designed for the purpose, or each individual harmonic shall be measured and from the measured values the *THD* shall be computed using the following formula:

$$THD = \sqrt{\sum_{n=2}^k u_n^2}$$

where

u_n is the ratio of the line-to-line terminal voltage U_n of the machine to the line-to-line terminal fundamental voltage U_1 of the machine;

n is the order of harmonic;

$k = 100$.

10 Rating plates

10.1 General

Every electrical machine shall be provided with a rating plate(s). The plates shall be made of durable material and be securely mounted. The writing has to be made with durable print.

The rating plate(s) shall preferably be mounted on the frame of the machine and be located so as to be easily legible in the position of use determined by the type of construction and

mounting arrangement of the machine. If the electrical machine is so enclosed or incorporated in the equipment that its rating plate is not easily legible, the manufacturer shall, on request, supply a second plate to be mounted on the equipment.

10.2 Marking

Machines with rated outputs up to and including 750 W (or VA) and dimensions not covered by IEC 60072 shall be marked with the information given in items a, b, k, l and z below as a minimum. For special-purpose and built-in machines with rated outputs up to and including 3 kW (or kVA) items a, b, k and l shall be marked as a minimum and item z may be provided in another form.

In all other cases, rating plate(s) shall be durably marked with the items in the following list, as far as they apply. The items need not all be on the same plate. Letter symbols for units and quantities shall be in accordance with IEC 60027-1 and IEC 60027-4.

If the manufacturer gives more information, this need not necessarily be marked on the rating plate(s).

The items are numbered for convenient reference, but the order in which they appear on the rating plate(s) is not standardized. Items may be suitably combined.

- a) The manufacturer's name or mark.
- b) The manufacturer's serial number, or identification mark.

NOTE A single identification mark may be used to identify each member of a group of machines which are made to the same electrical and mechanical design and are produced in one batch using the same technology.

- c) Information to identify the year of manufacture. This shall be marked on the rating plate or be given on a separate data sheet to be provided with the machine.

NOTE If this information can be obtained from the manufacturer by quoting the data specified in item b, it may be omitted from both the rating plate and the separate data sheet.

- d) The manufacturer's machine code.
- e) For a.c. machines, the number of phases.
- f) The number(s) of the rating and performance standard(s) which are applicable (IEC 60034-X and/or equivalent national standard(s)). If IEC 60034 is marked, this implies compliance with all the other relevant standards of the IEC 60034 series.
- g) The degree of protection provided by the integral design of the rotating electrical machine (IP code) in accordance with IEC 60034-5.
- h) For motors within the scope of IEC 60034-30, the efficiency class (IE code) and the rated efficiency as specified in IEC 60034-30.
- i) The thermal class and the limit of temperature or of temperature rise (when lower than that of the thermal class) and, if necessary, the method of measurement, followed in the case of a machine with a water-cooled heat exchanger by 'P' or 'S', depending on whether the temperature rise is measured above the primary or secondary coolant respectively (see 8.2). This information shall be given for both stator and rotor (separated by a slash) when their thermal class differ.
- j) The class(es) of rating of the machine if designed for other than rating for continuous running duty S1, see 5.2.
- k) The rated output(s) or range of rated output.
- l) The rated voltage(s) or range of rated voltage.
- m) For a.c. machines the rated frequency or range of rated frequency.

For universal motors, the rated frequency shall be followed by the appropriate symbol:
for example, ~ 50 Hz/ $\overline{\overline{\overline{\quad}}}$ or a.c. 50 Hz/DC.

- n) For synchronous machines excited by permanent magnets the open circuit voltage at rated speed.
- o) The rated current(s) or range of rated current.
- p) The rated speed(s) or range of rated speed.
- q) The permissible overspeed if other than specified in 9.7.
or
the maximum safe operating speed if less than in 9.6 or if the machine is designed especially for variable speed operation.
- r) For d.c. machines with separate excitation or with shunt excitation and for synchronous machines, the rated field voltage and the rated field current.
- s) For a.c. machines, the rated power factor(s).
- t) For wound-rotor induction machines, the rated open-circuit voltage between slip-rings and the rated slip-ring current.
- u) For d.c. motors with armatures intended to be supplied by static power converters, the identification code of the static power converter in accordance with IEC 60971. Alternatively, for motors not exceeding 5 kW, the rated form factor and the rated alternating voltage at the input terminals of the static power converter, when this exceeds the rated direct voltage of the motor armature circuit.
- v) The maximum ambient air temperature, if other than 40 °C.
The maximum water coolant temperature, if other than 25 °C.
- w) The minimum ambient air temperature if other than specified in 6.4.
- x) The altitude for which the machine is designed (if exceeding 1 000 m above sea-level).
- y) For hydrogen-cooled machines, the hydrogen pressure at rated output.
- z) When specified, the approximate total mass of the machine, if exceeding 30 kg.
- aa) For machines suitable for operation in only one direction of rotation, the direction of rotation, indicated by an arrow. This arrow need not be on the rating plate, but it shall be easily visible.
- bb) The connecting instructions in accordance with IEC 60034-8 by means of a diagram or text located near the terminals.

Two different rated values shall be indicated by X/Y and a range of rated values shall be indicated by X–Y (see IEC 61293).

Except for normal maintenance, when a machine is repaired or refurbished an additional plate shall be provided to indicate the name of the company undertaking the work, the year of repair and the changes made.

11 Miscellaneous requirements

11.1 Protective earthing of machines

Machines shall be provided with an earthing terminal or another device to permit the connection of a protective conductor or an earthing conductor.



The symbol  or legend shall identify this device. However, machines shall neither be earthed nor be provided with an earthing terminal when:

- a) they are fitted with supplementary insulation, or;
- b) they are intended for assembly in apparatus having supplementary insulation, or;

- c) they have rated voltages up to 50 V a.c. or 120 V d.c. and are intended for use on SELV circuits.

NOTE The term SELV is defined in IEC 60884-2-4.

In the case of machines having rated voltages greater than 50 V a.c. or 120 V d.c., but not exceeding 1 000 V a.c. or 1 500 V d.c., the terminal for the earthing conductor shall be situated in the vicinity of the terminals for the line conductors, being placed in the terminal box, if one is provided. Machines having rated outputs in excess of 100 kW (or kVA) shall have in addition an earthing terminal fitted on the frame.

Machines for rated voltages greater than 1 000 V a.c. or 1 500 V d.c. shall have an earthing terminal on the frame, for example an iron strap, and in addition, a means inside the terminal box for connecting a conducting cable sheath, if any.

The earthing terminal shall be designed to ensure a good connection with the earthing conductor without any damage to the conductor or terminal. Accessible conducting parts which are not part of the operating circuit shall have good electrical contact with each other and with the earthing terminal. When all bearings and the rotor winding of a machine are insulated, the shaft shall be electrically connected to the earthing terminal, unless the manufacturer and the purchaser agree to alternative means of protection.

When an earthing terminal is provided in the terminal box, it shall be assumed that the earthing conductor is made of the same metal as the lead conductors.

When an earthing terminal is provided on the frame, the earthing conductor may, by agreement, be made of another metal (for example, steel). In this case, in designing the terminal, proper consideration shall be given to the conductivity of the conductor.

The earthing terminal shall be designed to accommodate an earthing conductor of cross-sectional area in accordance with Table 19. If an earthing conductor larger than the size given in the table is used, it is recommended that it should correspond as nearly as possible to one of the other sizes listed.

For other cross-sectional areas of phase conductors, the earthing or protective conductor shall have a cross-sectional area at least equivalent to:

- that of the phase conductor for cross-sectional areas less than 25 mm²;
- 25 mm² for cross-sectional areas between 25 mm² and 50 mm²;
- 50 % of that of the phase conductor for cross-sectional areas exceeding 50 mm².

The earthing terminal shall be identified in accordance with IEC 60445.

Table 19 – Cross-sectional areas of earthing conductors

Cross-sectional area of the phase conductor mm ²	Cross-sectional area of the earthing or protective conductor mm ²
4	4
6	6
10	10
16	16
25	25
35	25
50	25
70	35
95	50
120	70
150	70
185	95
240	120
300	150
400	185

11.2 Shaft-end key(s)

When a machine shaft end is provided with one or more keyways, each shall be provided with a full key of normal shape and length.

12 Tolerances

12.1 General

Tolerance is the maximum allowed deviation between the test result of a quantity from Table 20 and the declared value on the rating plate or in the catalogue. As long as test procedures and test equipment according to IEC standards are used, the test result shall not exceed the allowed deviation independent of test laboratory or equipment. Tolerance does not cover the uncertainty of a test procedure, i.e. the deviation between the test result and the true value.

NOTE In case of a series production the tolerance applies to any selected sample, i.e. tolerance covers variations in raw material properties and manufacturing procedures.

12.2 Tolerances on values of quantities

Unless stated otherwise, tolerances on declared values shall be as specified in Table 20.

Table 20 – Schedule of tolerances on values of quantities

Item	Quantity	Tolerance
1	Efficiency η – machines up to and including 150 kW (or kVA) – machines above 150 kW (or kVA)	–15 % of $(1 - \eta)$ –10 % of $(1 - \eta)$
2	Total losses (applicable to machines with ratings >150 kW or kVA)	+10 % of the total losses
3	Power-factor, $\cos \phi$, for induction machines	–1/6 $(1 - \cos \phi)$ Minimum absolute value 0,02 Maximum absolute value 0,07
4	Speed of d.c. motors (at full load and at working temperature) ^a	
4a)	Shunt and separately excited motors	$1\,000 P_N/n_N < 0,67$ ± 15 % $0,67 \leq 1\,000 P_N/n_N < 2,5$ ± 10 % $2,5 \leq 1\,000 P_N/n_N < 10$ $\pm 7,5$ % $10 \leq 1\,000 P_N/n_N$ ± 5 %
4b)	Series motors	$1\,000 P_N/n_N < 0,67$ ± 20 % $0,67 \leq 1\,000 P_N/n_N < 2,5$ ± 15 % $2,5 \leq 1\,000 P_N/n_N < 10$ ± 10 % $10 \leq 1\,000 P_N/n_N$ $\pm 7,5$ %
4c)	Compound excited motors	Tolerances as for item 4b) unless otherwise agreed
5	Variation of speed of d.c. shunt and compound excited motors (from no-load to full load)	± 20 % of the variation with a minimum of ± 2 % of the rated speed
6	Inherent voltage regulation of d.c. generators, shunt or separately excited at any point on the characteristic	± 20 % of the regulation at that point
7	Inherent voltage regulation of compound excited generators (at the rated power-factor in the case of alternating current)	± 20 % of the regulation, with a minimum of ± 3 % of the rated voltage. (This tolerance applies to the maximum deviation at any load between the observed voltage at that load and a straight line drawn between the points of no-load and full-load voltage.)
8 a)	Slip of induction motors (at full load and at working temperature) $P_N < 1$ kW $P_N \geq 1$ kW	± 30 % of the slip ± 20 % of the slip
8 b)	Speed of a.c. (commutator) motors with shunt characteristics (at full load and at working temperature)	– on the highest speed: –3 % of the synchronous speed – on the lowest speed: +3 % of the synchronous speed
9	Locked rotor current of cage induction motors with any specified starting apparatus	+20 % of the current
10	Locked rotor torque of cage induction motors	+25 % of the torque. –15 % of the torque. (+25 % may be exceeded by agreement)

Table 20 (continued)

Item	Quantity	Tolerance
11	Pull-up torque of cage induction motors	–15 % of the value
12	Breakdown torque of induction motors	–10 % of the torque except that after allowing for this tolerance the torque shall be not less than 1,6 or 1,5 times the rated torque, see 9.4.1
13	Locked rotor current of synchronous motors	+ 20 % of the value
14	Locked rotor torque of synchronous motors	+25 –15 % of the value (+25 % may be exceeded by agreement)
15	Pull-out torque of synchronous motors	–10 % of the value except that after allowing for this tolerance, the torque shall be not less than 1,35 or 1,5 times the rated torque, see 9.4.2
16	Peak value of short-circuit current of an a.c. generator under specified conditions	±30 % of the value
17	Steady short-circuit current of an a.c. generator at specified excitation	±15 % of the value
18	Moment of inertia	±10 % of the value
NOTE When a tolerance is stated in only one direction, the value is not limited in the other direction.		
^a Tolerances in item 4 depend on the ratio of rated output P_N in kW, to rated speed in min^{-1} .		

13 Electromagnetic compatibility (EMC)

13.1 General

The following requirements apply to rotating electrical machines with rated voltages not exceeding 1 000 V a.c. or 1 500 V d.c. and which are intended for operation in industrial environments.

Electronic components mounted inside a rotating electrical machine and which are essential for its operation (for example rotating excitation devices) are part of the machine.

Requirements which apply to the final drive system and its components, for example power and control electronic equipment, coupled machines, monitoring devices, etc. whether mounted inside or outside the machine, are outside the scope of this standard.

The requirements of this clause apply to machines that are supplied directly to the end-user.

NOTE Machines that are intended for incorporation as components in an apparatus, where the enclosure and assembly will affect the EMC emissions, are covered by the EMC standard that relates to the final product.

Transients (such as starting) are not covered by this clause.

13.2 Immunity

13.2.1 Machines not incorporating electronic circuits

Machines without electronic circuits are not sensitive to electromagnetic emissions under normal service conditions and, therefore, no immunity tests are required.

ⓘ WARNING: Class A equipment is intended for use in an industrial environment. In the documentation for the user, a statement shall be included drawing attention to the fact that there may be potential difficulties in ensuring electromagnetic compatibility in other environments, due to conducted as well as radiated disturbances. **Ⓢ**

13.2.2 Machines incorporating electronic circuits

As electronic circuits which are incorporated in machines generally utilize components that are passive (for example diodes, resistors, varistors, capacitors, surge suppressors, inductors), immunity tests are not required.

13.3 Emission

13.3.1 Machines without brushes

Radiated and conducted emissions shall comply with the requirements of CISPR 11, Class B, Group 1, see Table B.1.

13.3.2 Machines with brushes

Radiated and conducted (if applicable) emissions shall comply with the requirements of CISPR 11, Class A, Group 1, see Table B.2.

13.4 Immunity tests

Immunity tests are not required.

13.5 Emission tests

Type tests shall be carried out in accordance with CISPR 11, CISPR 14 and CISPR 16 as applicable.

13.5.1 Machines without brushes

Machines without brushes shall comply with the emission limits of 13.3.1.

NOTE The emission from squirrel cage induction motors are always so low that testing is not needed.

13.5.2 Machines with brushes

Machines with brushes, when tested at no-load, shall comply with the emission limits of 13.3.2.

NOTE 1 The no-load measurement is justified by the negligible influence of load on the emission.

NOTE 2 There are no conducted emissions from d.c. machines, as they are not directly connected to the a.c. supply.

NOTE 3 The emission from earthing brushes are always so low that testing is not needed.

14 Safety

Rotating machines in accordance with this standard shall comply with the requirements of IEC 60204-1 or IEC 60204-11 or, in the case of rotating machines incorporated in household and similar electrical appliances, IEC 60335-1, as appropriate unless otherwise specified in this standard, and be designed and constructed as far as possible in accordance with internationally accepted best design practice, appropriate to the application.

NOTE It is the responsibility of the manufacturer or assembler of equipment incorporating electrical machines as components to ensure that the overall equipment is safe.

This may involve consideration of relevant product standards such as:

IEC 60079 (all parts), *Explosive atmospheres* [8],

and other parts of IEC 60034 including:

IEC 60034-5, IEC 60034-6 [1], IEC 60034-7 [2], IEC 60034-8, IEC 60034-9 [3], IEC 60034-11 [4], IEC 60034-12 and IEC 60034-14 [5].

In addition, it may be necessary to consider limitation of the surface temperature and similar characteristics; see for example IEC 60335-1, Clause 11: Heating.

Annex A (informative)

Guidance for the application of duty type S10 and for establishing the value of relative thermal life expectancy TL

A.1 The load of the machine at any moment is equivalent to duty type S1 corresponding to 4.2.1. However, the load cycle may comprise loads other than the rated load based on duty type S1. A load cycle comprising four discrete constant load/speed combinations is shown in Figure 10.

A.2 Depending on the value and duration of the different loads within one cycle, the relative life expectancy of the machine based on the thermal ageing of the insulation system can be calculated by the following equation:

$$\frac{1}{TL} = \sum_{i=1}^n \Delta t_i \times 2^{\frac{\Delta\Theta_i}{k}}$$

where

TL is the relative thermal life expectancy related to the thermal life expectancy in case of duty type S1 with rated output;

$\Delta\Theta_i$ is the difference between the temperature rise of the winding at each of the various loads within one cycle and the temperature rise based upon duty type S1 with reference load;

Δt_i is the p.u. time of a constant load within a load cycle;

k is the increase in temperature rise in K, which leads to a shortening of the thermal life expectancy of the insulation system by 50 %;

n is the number of discrete values of load.

A.3 The quantity TL is an integral part of the unambiguous identification of the class of rating.

A.4 The value of the quantity TL can be determined only when, in addition to information concerning the load cycle according to Figure 10, the value k for the insulation system is known. This value k has to be determined by experiments in conformity with IEC 60034-18 for the whole temperature range within which the load cycle takes place according to Figure 10.

A.5 TL can be stated sensibly as a relative value only. This value can be used by approximation to assess the real change in the machine thermal life expectancy as compared to duty type S1 with rated output, because it may be assumed that in consideration of the varying loads existing within a cycle the remaining influences over the lifetime of the machine (e.g. dielectric stress, environmental influences) are approximately the same as in the case of duty type S1 with rated output.

A.6 The manufacturer of the machine is responsible for the correct compilation of the various parameters for determining the value of TL .

Annex B (informative)

Electromagnetic compatibility (EMC) limits

Table B.1 – Electromagnetic emission limits for machines without brushes

	Frequency range	Limits
Radiated emission	30 MHz to 230 MHz	30 dB(μ V/m) quasi peak, measured at 10 m distance (Note 1)
	230 MHz to 1 000 MHz	37 dB(μ V/m) quasi peak, measured at 10 m distance (Note 1)
Conducted emission on a.c. supply terminals	0,15 MHz to 0,50 MHz Limits decrease linearly with logarithm frequency	66 dB(μ V) to 56 dB(μ V) quasi peak 56 dB(μ V) to 46 dB(μ V) average
	0,50 MHz to 5 MHz	56 dB(μ V) quasi peak 46 dB(μ V) average
	5 MHz to 30 MHz	60 dB(μ V) quasi peak 50 dB(μ V) average
NOTE 1 May be measured at 3 m distance using the limits increased by 10 dB.		
NOTE 2 Emission limits are from CISPR 11, Class B, Group 1.		

Table B.2 – Electromagnetic emission limits for machines with brushes

	Frequency range	Limits
Radiated emission	30 MHz to 230 MHz	30 dB(μ V/m) quasi peak, measured 30 m distance (Note 1)
	230 MHz to 1 000 MHz	37 dB(μ V/m) quasi peak, measured 30 m distance (Note 1)
Conducted emission on a.c. supply terminals	0,15 MHz to 0,50 MHz	79 dB(μ V) quasi peak 66 dB(μ V) average
	0,50 MHz to 30 MHz	73 dB(μ V) quasi peak 60 dB(μ V) average
NOTE 1 May be measured at 10 m distance using the limits increased by 10 dB or measured at 3 m distance using the limits increased by 20 dB.		
NOTE 2 Emission limits are from CISPR 11, Class A, Group 1.		

Bibliography

- [1] IEC 60034-6, *Rotating electrical machines – Part 6: Methods of cooling (IC code)*
 - [2] IEC 60034-7, *Rotating electrical machines – Part 7: Classification of types of construction, mounting arrangements and terminal box position (IM code)*
 - [3] IEC 60034-9, *Rotating electrical machines – Part 9: Noise limits*
 - [4] IEC 60034-11, *Rotating electrical machines – Part 11: Thermal protection*
 - [5] IEC 60034-14, *Rotating electrical machines – Part 14: Mechanical vibration of certain machines with shaft heights 56 mm and higher – Measurement, evaluation and limits of vibration severity*
 - [6] IEC 60034-29, *Rotating electrical machines – Part 29: Equivalent loading and superposition techniques – Indirect testing to determine temperature rise*
 - [7] IEC 60050-811:1991, *International Electrotechnical Vocabulary – Chapter 811: Electric traction*
 - [8] IEC 60079 (all parts), *Explosive atmospheres*
 - [9] IEC 60092 (all parts), *Electrical installations in ships*
 - [10] IEC 60349 (all parts), *Electric traction – Rotating electrical machines for rail and road vehicles*
-

British Standards Institution (BSI)

BSI is the independent national body responsible for preparing British Standards and other standards-related publications, information and services.

It presents the UK view on standards in Europe and at the international level.

It is incorporated by Royal Charter.

Revisions

British Standards are updated by amendment or revision. Users of British Standards should make sure that they possess the latest amendments or editions.

It is the constant aim of BSI to improve the quality of our products and services. We would be grateful if anyone finding an inaccuracy or ambiguity while using this British Standard would inform the Secretary of the technical committee responsible, the identity of which can be found on the inside front cover.

Tel: +44 (0)20 8996 9001 Fax: +44 (0)20 8996 7001

BSI offers Members an individual updating service called PLUS which ensures that subscribers automatically receive the latest editions of standards.

Tel: +44 (0)20 8996 7669 Fax: +44 (0)20 8996 7001

Email: plus@bsigroup.com

Buying standards

You may buy PDF and hard copy versions of standards directly using a credit card from the BSI Shop on the website www.bsigroup.com/shop. In addition all orders for BSI, international and foreign standards publications can be addressed to BSI Customer Services.

Tel: +44 (0)20 8996 9001 Fax: +44 (0)20 8996 7001

Email: orders@bsigroup.com

In response to orders for international standards, it is BSI policy to supply the BSI implementation of those that have been published as British Standards, unless otherwise requested.

Information on standards

BSI provides a wide range of information on national, European and international standards through its Knowledge Centre.

Tel: +44 (0)20 8996 7004 Fax: +44 (0)20 8996 7005

Email: knowledgecentre@bsigroup.com

Various BSI electronic information services are also available which give details on all its products and services.

Tel: +44 (0)20 8996 7111 Fax: +44 (0)20 8996 7048

Email: info@bsigroup.com

BSI Subscribing Members are kept up to date with standards developments and receive substantial discounts on the purchase price of standards. For details of these and other benefits contact Membership Administration.

Tel: +44 (0)20 8996 7002 Fax: +44 (0)20 8996 7001

Email: membership@bsigroup.com

Information regarding online access to British Standards via British Standards Online can be found at www.bsigroup.com/BSOL

Further information about BSI is available on the BSI website at www.bsigroup.com/standards

Copyright

Copyright subsists in all BSI publications. BSI also holds the copyright, in the UK, of the publications of the international standardization bodies. Except as permitted under the Copyright, Designs and Patents Act 1988 no extract may be reproduced, stored in a retrieval system or transmitted in any form or by any means – electronic, photocopying, recording or otherwise – without prior written permission from BSI. This does not preclude the free use, in the course of implementing the standard of necessary details such as symbols, and size, type or grade designations. If these details are to be used for any other purpose than implementation then the prior written permission of BSI must be obtained. Details and advice can be obtained from the Copyright & Licensing Manager.

Tel: +44 (0)20 8996 7070

Email: copyright@bsigroup.com

BSI Group Headquarters

389 Chiswick High Road London W4 4AL UK

Tel +44 (0)20 8996 9001

Fax +44 (0)20 8996 7001

www.bsigroup.com/standards