

BS EN 50600-2-4:2015



BSI Standards Publication

Information technology — Data centre facilities and infrastructures -

Part 2-4: Telecommunications cabling
infrastructure

bsi.

...making excellence a habit.™

National foreword

This British Standard is the UK implementation of EN 50600-2-4:2015.

The UK participation in its preparation was entrusted to Technical Committee TCT/7/3, Telecommunications; Installation requirements: Facilities and infrastructures.

A list of organizations represented on this committee can be obtained on request to its secretary.

This publication does not purport to include all the necessary provisions of a contract. Users are responsible for its correct application.

© The British Standards Institution 2015.

Published by BSI Standards Limited 2015

ISBN 978 0 580 85319 7

ICS 35.020; 35.110; 35.160

Compliance with a British Standard cannot confer immunity from legal obligations.

This British Standard was published under the authority of the Standards Policy and Strategy Committee on 30 April 2015.

Amendments/corrigenda issued since publication

Date	Text affected
------	---------------

EUROPEAN STANDARD

EN 50600-2-4

NORME EUROPÉENNE

EUROPÄISCHE NORM

March 2015

ICS 35.020; 35.110; 35.160

English Version

**Information technology - Data centre facilities and infrastructures
- Part 2-4: Telecommunications cabling infrastructure**

Technologie de l'information - Installation et infrastructures
de centres de traitement de données - Partie 2-4:
Infrastructure du câblage dédié télécommunications

Informationstechnik - Einrichtungen und Infrastrukturen von
Rechenzentren - Teil 2-4: Infrastruktur der
Telekommunikationsverkabelung

This European Standard was approved by CENELEC on 2015-02-16. CENELEC members are bound to comply with the CEN/CENELEC Internal Regulations which stipulate the conditions for giving this European Standard the status of a national standard without any alteration.

Up-to-date lists and bibliographical references concerning such national standards may be obtained on application to the CEN-CENELEC Management Centre or to any CENELEC member.

This European Standard exists in three official versions (English, French, German). A version in any other language made by translation under the responsibility of a CENELEC member into its own language and notified to the CEN-CENELEC Management Centre has the same status as the official versions.

CENELEC members are the national electrotechnical committees of Austria, Belgium, Bulgaria, Croatia, Cyprus, the Czech Republic, Denmark, Estonia, Finland, Former Yugoslav Republic of Macedonia, France, Germany, Greece, Hungary, Iceland, Ireland, Italy, Latvia, Lithuania, Luxembourg, Malta, the Netherlands, Norway, Poland, Portugal, Romania, Slovakia, Slovenia, Spain, Sweden, Switzerland, Turkey and the United Kingdom.



European Committee for Electrotechnical Standardization
Comité Européen de Normalisation Electrotechnique
Europäisches Komitee für Elektrotechnische Normung

CEN-CENELEC Management Centre: Avenue Marnix 17, B-1000 Brussels

Content

Foreword	5
Introduction	6
1 Scope	8
2 Normative references	8
3 Terms, definitions and abbreviations	9
3.1 Terms and definitions	9
3.2 Abbreviations.....	10
4 Conformance	11
5 Telecommunications cabling within the data centre	11
5.1 General.....	11
5.2 Information technology and network telecommunications cabling in the computer room space.....	14
5.3 Structured cabling for other data centre spaces and application specific structured cabling	16
6 Availability design principles for telecommunications cabling infrastructure	17
7 Availability classification for telecommunications cabling infrastructure	17
7.1 General.....	17
7.2 Telecommunications cabling for the computer room	18
7.3 Telecommunications cabling for offices	22
7.4 Telecommunications cabling for monitoring and control.....	22
8 Pathways and pathway systems for telecommunications cabling	22
8.1 General.....	22
8.2 Pathways.....	23
8.3 Pathway systems	24
9 Cabinets and racks for the computer room space	25
9.1 General requirements.....	25
9.2 Requirements for dimensions	25
9.3 Recommendations	25
10 Documentation and quality plan	25
10.1 Requirements for documentation	25
10.2 Recommendations for documentation	25
10.3 Requirements for the quality plan	26
11 Management and operation of the telecommunications cabling infrastructure	26
11.1 General.....	26
11.2 Automated infrastructure management systems	26
11.3 Fibre optic cabling	26
Annex A (normative) Cabling design concepts	27
A.1 General	27

A.2 Class 1 cabling concept	27
A.3 Class 2 cabling concepts	28
A.4 Class 3 cabling concepts	30
A.5 Class 4 cabling concepts	32
Annex B (informative) Energy efficiency considerations for the telecommunications cabling infrastructure	35
Bibliography.....	36
Figures	
Figure 1 - Schematic relationship between the EN 50600 standards	7
Figure 2 – Impact of growth in an unstructured point-to-point cabling infrastructure	13
Figure 3 – Example of point-to-point cabling.....	13
Figure 4 – Structured cabling infrastructure: setup and growth	14
Figure 5 – Data centre cabling subsystems according to EN 50173-5	15
Figure 6 – Office cabling subsystems according to EN 50173-2	15
Figure 7 – Building service cabling subsystem according to EN 50173-6	16
Figure 8 – Telecommunication cabling Class 1 using direct attached cords	18
Figure 9 – Transmission channels (interconnect and cross-connect).....	19
Figure 10 – ENI redundancy for Class 1 and 2	19
Figure 11 – Managing moves, adds and changes	20
Figure 12 - Redundant multipath telecommunication cabling Class 3	20
Figure 13 - Redundant multipath telecommunication cabling Class 4	21
Figure A.1 – Symbols of network elements.....	27
Figure A.2 – Example of a Class 1 cabling implementation.....	27
Figure A.3 – Example for Class 2 EoR cabling implementation.....	28
Figure A.4 – Example for Class 2 MoR cabling implementation	29
Figure A.5 – Example for Class 2 ToR cabling implementation.....	30
Figure A.6 – Example for Class 3 EoR cabling implementation.....	31
Figure A.7 – Example for Class 3 ToR cabling implementation.....	32
Figure A.8 – Example for Class 4 EoR cabling implementation.....	33

Figure A.9 – Example for Class 4 ToR cabling implementation 34

Tables

Table 1 – Telecommunication cabling Availability Classes per space architecture and overall data centre
Availability Class for facilities and infrastructures 18

Foreword

This document (EN 50600-2-4:2015) has been prepared by CLC/TC 215 "Electrotechnical aspects of telecommunication equipment".

The following dates are fixed:

- latest date by which this document has to be implemented at national level by publication of an identical national standard or by endorsement (dop) 2016-02-16
- latest date by which the national standards conflicting with this document have to be withdrawn (dow) 2018-02-16

Attention is drawn to the possibility that some of the elements of this document may be the subject of patent rights. CENELEC [and/or CEN] shall not be held responsible for identifying any or all such patent rights.

This document has been prepared under a mandate given to CENELEC by the European Commission and the European Free Trade Association.

Introduction

The unrestricted access to internet-based information demanded by the information society has led to an exponential growth of both internet traffic and the volume of stored/retrieved data. Data centres are housing and supporting the information technology and network telecommunications equipment for data processing, data storage and data transport. They are required both by network operators (delivering those services to customer premises) and by enterprises within those customer premises.

Data centres need to provide modular, scalable and flexible facilities and infrastructures to easily accommodate the rapidly changing requirements of the market. In addition, energy consumption of data centres has become critical both from an environmental point of view (reduction of carbon footprint) and with respect to economical considerations (cost of energy) for the data centre operator.

The implementation of data centres varies in terms of:

- a) purpose (enterprise, co-location, co-hosting or network operator facilities);
- b) security level;
- c) physical size;
- d) accommodation (mobile, temporary and permanent constructions).

The needs of data centres also vary in terms of availability of service, the provision of security and the objectives for energy efficiency. These needs and objectives influence the design of data centres in terms of building construction, power distribution, environmental control and physical security. Effective management and operational information is required to monitor achievement of the defined needs and objectives.

This series of European Standards specifies requirements and recommendations to support the various parties involved in the design, planning, procurement, integration, installation, operation and maintenance of facilities and infrastructures within data centres. These parties include:

- 1) owners, facility managers, ICT managers, project managers, main contractors;
- 2) architects, building designers and builders, system and installation designers;
- 3) facility and infrastructure integrators, suppliers of equipment;
- 4) installers, maintainers.

At the time of publication of this European Standard, EN 50600 series will comprise the following standards:

EN 50600-1, *Information technology - Data centre facilities and infrastructures - Part 1: General concepts*

EN 50600-2-1, *Information technology - Data centre facilities and infrastructures - Part 2-1: Building construction*

EN 50600-2-2, *Information technology - Data centre facilities and infrastructures - Part 2-2: Power distribution*

EN 50600-2-3, *Information technology - Data centre facilities and infrastructures - Part 2-3: Environmental control*

EN 50600-2-4, *Information technology - Data centre facilities and infrastructures - Part 2-4: Telecommunications cabling infrastructure*

EN 50600-2-5, *Information technology - Data centre facilities and infrastructures - Part 2-5: Security systems*

EN 50600-3-1, *Information technology - Data centre facilities and infrastructures - Part 3-1: Management and operational information*

The inter-relationship of the standards within the EN 50600 series is shown in Figure 1.

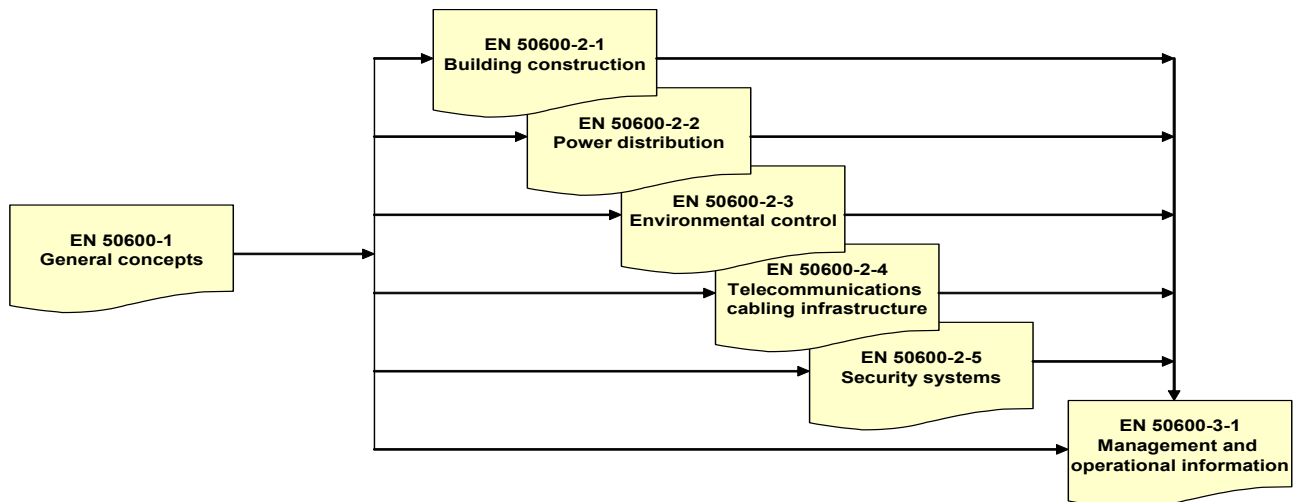

Figure 1 - Schematic relationship between the EN 50600 standards

EN 50600-2-X standards specify requirements and recommendations for particular facilities and infrastructures to support the relevant classification for “availability”, “security” and “energy efficiency enablement” selected from EN 50600-1.

EN 50600-3-X documents specify requirements and recommendations for data centre operations, processes and management.

This European Standard addresses the specific requirements for the telecommunications cabling infrastructure in data centres used for the purpose of IT networking and building services (in accordance with the requirements of EN 50600-1).

This European Standard is intended for use by and collaboration between architects, building designers and builders, system and installation designers.

This series of European Standards does not address the selection of information technology and network telecommunications equipment, software and associated configuration issues.

1 Scope

This European Standard addresses the wide range of telecommunications cabling infrastructures within data centres based upon the criteria and classifications for “availability” within EN 50600-1.

This European Standard specifies requirements and recommendations for the following:

- a) information technology and network telecommunications cabling (e.g. SAN and LAN);
- b) general information technology cabling to support the operation of the data centre;
- c) telecommunications cabling to monitor and control, as appropriate, power distribution, environmental control and physical security of the data centre;
- d) other building automation cabling;
- e) pathways, spaces and enclosures for the telecommunications cabling infrastructures.

Safety and electromagnetic compatibility (EMC) requirements are outside the scope of this European Standard and are covered by other standards and regulations. However, information given in this European Standard may be of assistance in meeting these standards and regulations.

2 Normative references

The following documents, in whole or in part, are normatively referenced in this document and are indispensable for its application. For dated references, only the edition cited applies. For undated references, the latest edition of the referenced document (including any amendments) applies.

EN 50173-1, *Information technology - Generic cabling systems - Part 1: General requirements*

EN 50173-2, *Information technology - Generic cabling systems - Part 2: Office premises*

EN 50173-5, *Information technology - Generic cabling systems - Part 5: Data centres*

EN 50173-6, *Information technology - Generic cabling systems – Part 6: Distributed building services*

EN 50174-1, *Information technology - Cabling installation - Part 1: Installation specification and quality assurance*

EN 50174-2, *Information technology - Cabling installation - Part 2 Installation planning and practices inside buildings*

EN 50600-1:2012, *Information technology - Data centre facilities and infrastructures - Part 1: General concepts*

EN 50600-2-1, *Information technology - Data centre facilities and infrastructures – Part 2-1: Building construction*

EN 50600-2-3, *Information technology - Data centre facilities and infrastructures - Part 2-3: Environmental control*

EN 50600-3-1¹⁾, *Information technology - Data centre facilities and infrastructures - Part 3-1: Management and operational information*

¹⁾ Submitted to formal vote.

3 Terms, definitions and abbreviations

3.1 Terms and definitions

For the purposes of this document, the terms and definitions given in EN 50600-1 and the following apply.

3.1.1

application-specific cabling

structured cabling with a configuration and performance which is considered to provide a specific benefit for a single, or limited number of applications, as compared to generic cabling

3.1.2

central patching location

passive cross-connect to connect different functional elements of a data centre

Note 1 to entry: A central patching location can be located in the main distribution area and/or the intermediate distribution area and is therefore a special configuration of an MD and/or an ID.

3.1.3

cross-connect

method of connecting a patch panel port to another patch panel port by the use of a patch cord or jumper

3.1.4

data centre information technology equipment

equipment in the computer room space of a data centre that transports and/or stores and/or processes information

3.1.5

fixed cabling

cabling subsystem between closures which has either a peer-to-peer or hierarchical structure and which enables the installation of cross-connects or interconnects at those closures

3.1.6

generic cabling

structured telecommunications cabling system, capable of supporting a wide range of applications

Note 1 to entry: Application-specific hardware is not a part of generic cabling.

Note 2 to entry: Generic cabling can be installed without prior knowledge of the required applications.

[SOURCE: EN 50173-1:2011, 3.1.40 – modified: changed the editorial presentation of NOTES]

3.1.7

interconnect

method of connecting a patch panel port to an equipment port by the use of equipment cords

3.1.8

office network information technology equipment

equipment in data centre spaces that transports and/or stores and/or processes information

3.1.9

point-to-point connection

direct connection of two pieces of IT equipment using a dedicated cable rather than a generic cabling system

3.1.10

structured cabling

telecommunications cabling comprising fixed cables between points of distribution at which equipment or other fixed cables may be connected

3.1.11

telecommunications provider

either an access provider or a service provider

Note 1 to entry: The term access provider is defined in EN 50174-2:2009/A2:2014, 3.1.1.

Note 2 to entry: The term service provider is defined in EN 50174-2:2009/A2:2014, 3.1.30.

3.1.12

zone patching location

passive cross-connect to connect different function elements of a data centre zone. A zone patching location can be located in the zone distribution area and is therefore a special configuration of a ZD.

3.2 Abbreviations

For the purposes of this document, the abbreviations given in EN 50600-1 and the following abbreviations apply.

BEF	Building Entrance Facility
BD	Building Distributor
C	Connection
CD	Campus Distributor
CP	Consolidation Point
CPL	Central Patching Location
ENI	External Network Interface
EO	Equipment Outlet
EoR	End of Row
EQP	Transmission Equipment
FD	Floor Distributor
ID	Intermediate Distributor
LDP	Local Distribution Point
MD	Main Distributor
MoR	Middle of Row
SCP	Service Concentration Point
SD	Service Distributor
SO	Service Outlet
TE	Terminal Equipment
TO	Telecommunications Outlet

ToR	Top of Rack
ZD	Zone Distributor
ZPL	Zone Patching Location

4 Conformance

For a data centre to conform to this European Standard:

- a) the cabling design shall meet the requirements of Clause 5;
- b) the cabling design for the selected Availability Class shall be in accordance with Clause 7;
- c) the design and specifications of pathways and spaces shall be in accordance with Clauses 8 and 9;
- d) the information technology cabling to support the operation of the data centre shall be in accordance with EN 50173-2, except where 7.3 allows an alternative approach ;
- e) the information technology cabling to support the IT networking function of the data centre shall be in accordance with EN 50173-5, except where 7.2 allows an alternative approach;
- f) telecommunications cabling for monitoring and/or control of power distribution, environmental control and physical security shall be in accordance with EN 50173-6, except where 7.4 allows an alternative approach;
- g) installation specification, quality assurance, installation planning and practice of cabling shall be in accordance with EN 50174 series and Clauses 8 and 9;
- h) national and local regulations, including safety, shall be met.

5 Telecommunications cabling within the data centre

5.1 General

5.1.1 The importance of telecommunications cabling within data centre spaces

The telecommunications cabling within the data centre serves to support the following:

- a) data centre information technology and network telecommunications;
- b) monitoring and controlling of other data centre infrastructures;
- c) building management and automation.

The design and planning of cabling infrastructures should be undertaken at an early stage of the data centre design or refurbishment and should be integrated with the design and planning of:

- 1) electrical power;
- 2) environmental control systems;
- 3) security systems;
- 4) lighting systems.

This clause defines the requirements and recommendations for the performance, design criteria and architectures for the different cabling types in a data centre.

The importance of the information technology and network telecommunications cabling infrastructure is similar to that of other infrastructures such as environmental control, power distribution and security. As with other utilities, interruptions to service can have a serious impact. Poor quality of service due to lack of planning, use of inappropriate components, incorrect installation, poor administration or inadequate support can threaten an organisation's effectiveness.

5.1.2 Cabling implementation

The cabling infrastructures in a data centre shall be appropriate to provide networking and telecommunications capabilities in and between dedicated data centre spaces.

For the purposes of this standard, two types of cabling are considered for data centre spaces:

- a) point-to-point;
- b) fixed cabling implemented using structured cabling including the generic cabling solutions of the EN 50173 series. The closures may be grouped and accommodated in cabinets, frames or racks which act as cabling presentation facilities. The cabling presentation facilities allow interconnection or cross-connections between fixed cabling or between fixed cabling and IT equipment in close proximity.

5.1.3 Point-to-point cabling

5.1.3.1 General

The point-to-point connection method uses discrete cords (typically factory-produced) that directly connect the active equipment. Each cord connects a single port of one device to a single port of another device.

Although point-to-point cabling seems to be the simplest and most cost effective method of providing connections, for several reasons this cabling type should only be used for connections within the same or two adjacent cabinets, frames or racks. Point-to-point cabling is often not reusable as the data centre evolves and equipment types and locations change and may have a limited life time expectation. Continuous changes to the required interconnections increase both the planning and the operational resources required for each change (see Figure 2 and Figure 3) and increases the risk of interfering with other infrastructures - including those for environmental control.

5.1.3.2 Restrictions on the use of point-to-point cabling

Where this standard allows point-to-point cabling, it should only be used subject to the following restrictions:

- a) the mechanical performance of cords or cables used for point-to-point connections shall meet the requirements of the installation environment (e.g. pathway systems);
- b) connectors on cords shall be protected against damage during installation, disconnection or removal;
- c) point-to-point connections shall only be used where the replacement of the cord following damage to either connector can be performed without disruption to the data centre operation;
- d) cords shall be managed so as to avoid mechanical damage and/or accidental disconnection to adjacent connections during insertion or removal;
- e) cords shall be labelled at both ends to show their origin and destination in accordance with the level 3 administration requirements of EN 50174-1;
- f) the impact of point to point connections on the fire load of cabling shall be assessed and mitigation provided if necessary;
- g) cords providing point-to-point connections shall not be located where they restrict cooling airflow towards active equipment.

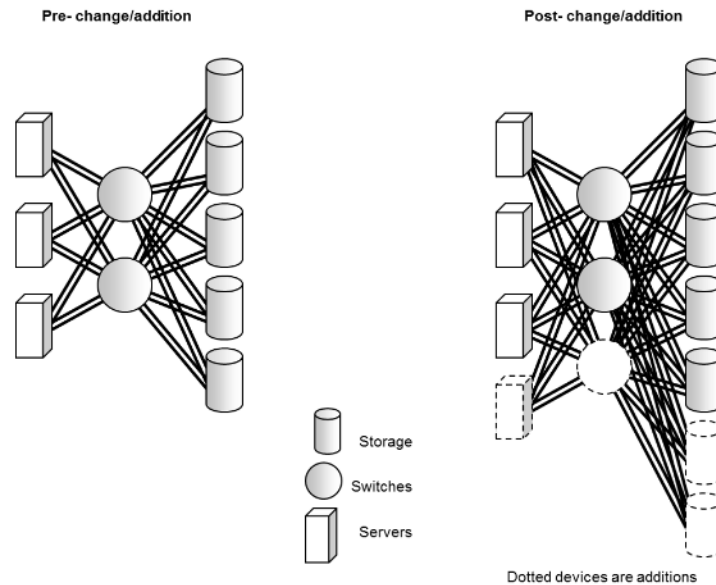

Figure 2 – Impact of growth in an unstructured point-to-point cabling infrastructure

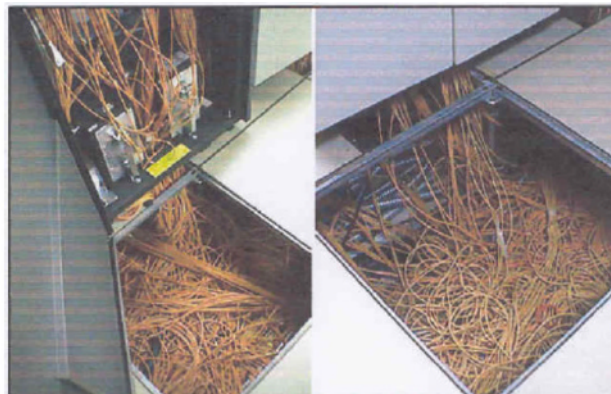

Figure 3 – Example of point-to-point cabling

5.1.4 Fixed cabling

A structured cabling system approach, illustrated in Figure 4, shows the equipment ports presented at remote central patching locations (CPLs). Server-to-storage connections are made using short, easily managed, cords within the CPL. The use of distributed zone patching locations (ZPL), connected to the CPLs with fixed cables provides additional flexibility for managing changes.

Figure 4 shows how a fixed cabling implementation isolates the change activity to the defined areas. New equipment is connected to a CPL or ZPL without impacting active systems so no scheduled downtime is required. The equipment can then be connected to the active systems during the scheduled downtime by simply reconfiguring the cords at the CPL or ZPL. If a change causes a problem, it is only necessary to reconnect the cords into their pre-change configuration. The structured approach enables more accurate predictions of the time required to implement system changes and recovery resulting in easier, faster changes that introduce less risk and enable improved overall system operation.

Fixed cables may have a greater minimum bending radius than cords and this shall be considered in pathway and pathway system design and planning.

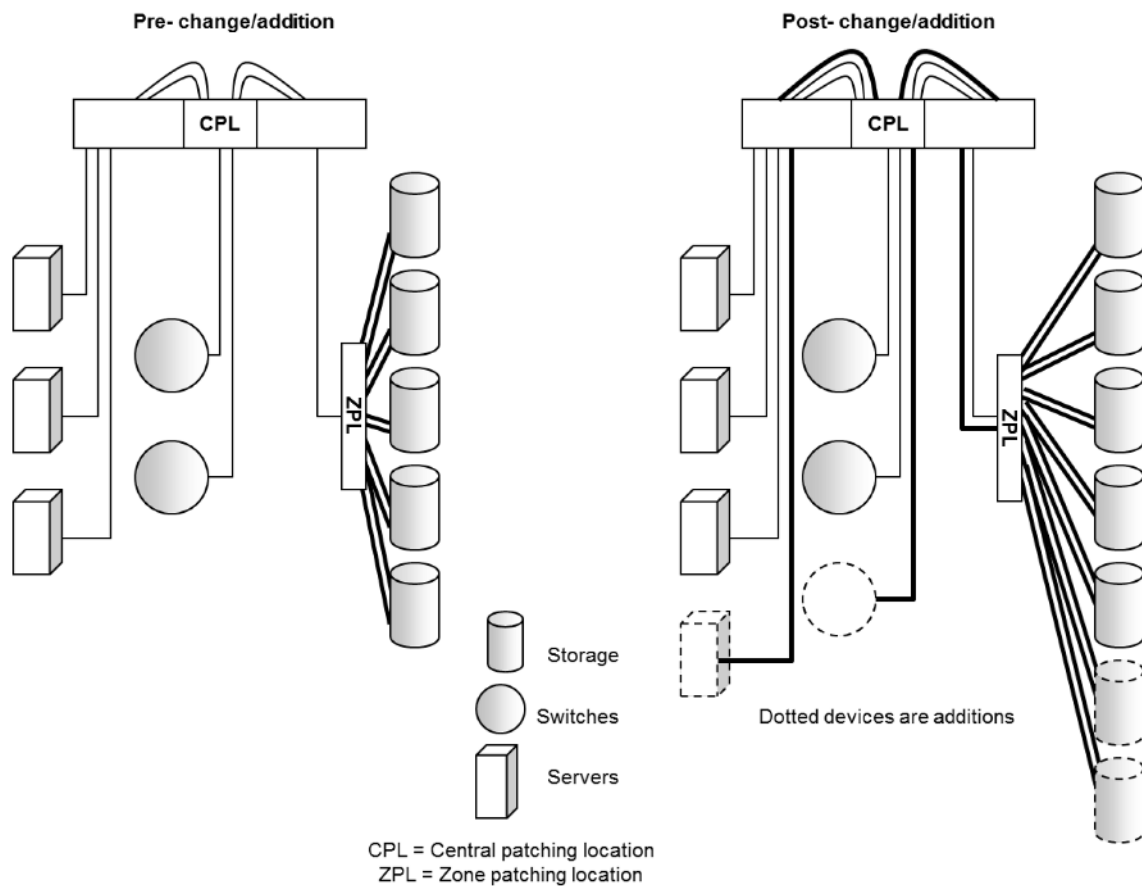

Figure 4 – Structured cabling infrastructure: setup and growth

5.2 Information technology and network telecommunications cabling in the computer room space

5.2.1 General

The cabling infrastructures in a data centre shall be appropriate to provide networking and telecommunications capabilities in and between many of the dedicated data centres spaces. The cabling infrastructure described in this clause is that between and within the cabinets, frames and racks which constitute the computer room space and may take one of, or a combination of, the following forms:

- a) point-to-point;
- b) fixed:
 - 1) generic - structured cabling in accordance with EN 50173-5 for IT and network telecommunications;
 - 2) generic - structured cabling in accordance to EN 50173-2 for IT and network telecommunications;
 - 3) generic - structured cabling in accordance with EN 50173-6 for monitoring and control;
 - 4) application specific cabling.

The chosen infrastructure strategy shall take into account the need to support existing and future networking and storage applications and significant amounts of change.

5.2.2 Generic cabling for data centre information technology equipment

Generic cabling infrastructure designs in accordance with the EN 50173 series are based upon a defined cabling model and support the development of high data rate applications. EN 50173-5 defines generic cabling to provide multiple services and to connect large quantities of equipment within the limited space of data centre premises, and is to be used together with EN 50173-1.

Information technology cabling to support the operation of the data centre shall be in accordance with EN 50173-5.

Figure 5 shows the cabling subsystem architecture of EN 50173-5.

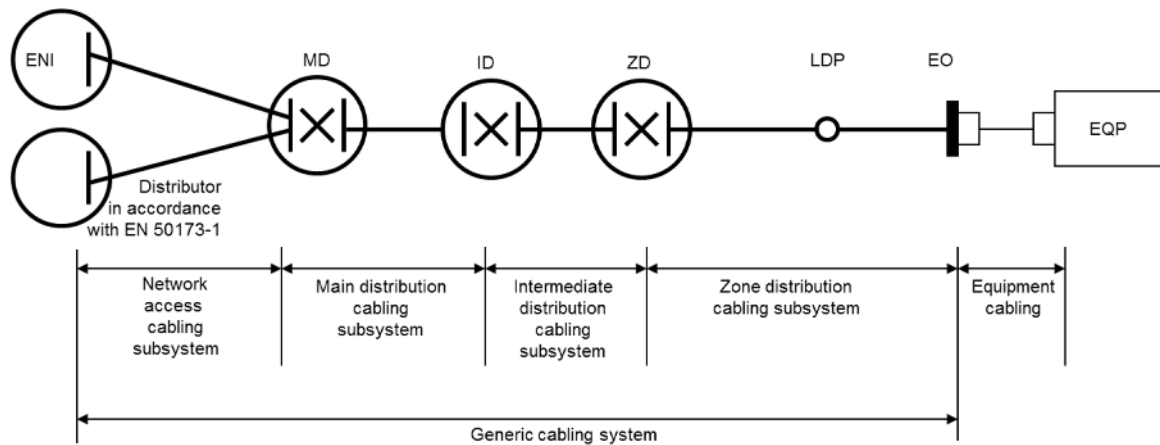

Figure 5 – Data centre cabling subsystems according to EN 50173-5

Generic cabling in accordance with EN 50173-5 uses pre-defined pathways and spaces that are specifically intended to support changing demands and provides:

- a) scalability via a modular design;
- b) a greater level of flexibility with equipment moves, adds and changes;
- c) a level of consistency with generic cabling design methodology for other services such as power supply distribution and environmental control;
- d) the support for a wide range of applications in the data centre.

Generic cabling systems are intended to avoid the impact of the uncontrolled use of point-to-point cables described in 5.1.3.2 by using fixed cables within defined cable pathways between panels (patch panel) at designated patching locations. This greatly simplifies cabling modifications by managing changes at the patching locations rather than disconnecting, moving and reconnecting discrete cables under the floor or in ceiling spaces.

5.2.3 Generic cabling for office network information technology equipment

Information technology cabling to support the operation of the data centre shall be in accordance with EN 50173-2.

Figure 6 shows the cabling subsystem architecture of EN 50173-2.

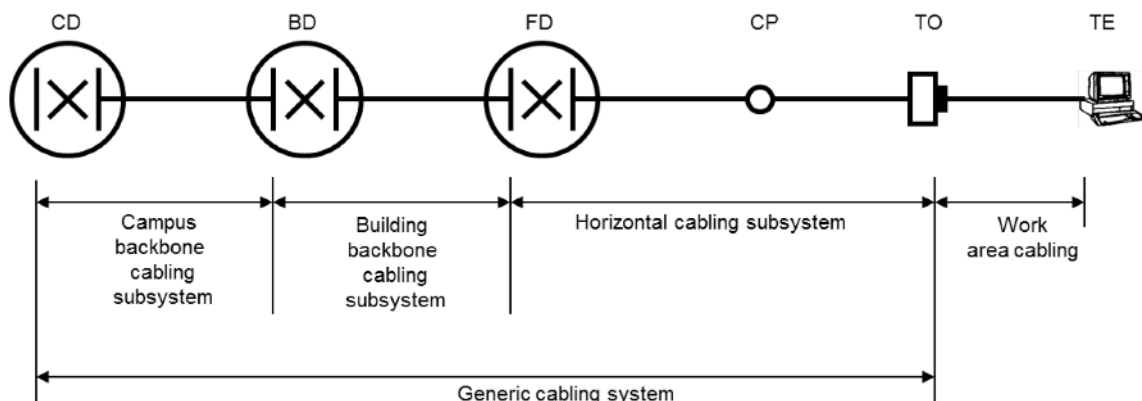

Figure 6 – Office cabling subsystems according to EN 50173-2

5.2.4 Generic Cabling for monitoring and control

EN 50173-6 specifies generic cabling that supports a wide range of communication services within premises. It reflects the increasing use of generic cabling in support of non-user specific services, including the monitoring and control of data centre infrastructures. Many of these services require the use of remote powered devices and include:

- a) energy management as described in EN 50600-2-2: e.g. lighting, power distribution, incoming utility metering;
- b) environmental control as described in EN 50600-2-3; e.g. temperature, humidity;
- c) personnel management as described in EN 50600-2-5, e.g. access control, cameras, motion/proximity detectors, time and attendance monitoring.

Cabling for these purposes shall be in accordance with EN 50173-6.

Figure 7 shows the cabling subsystem architecture of EN 50173-6.

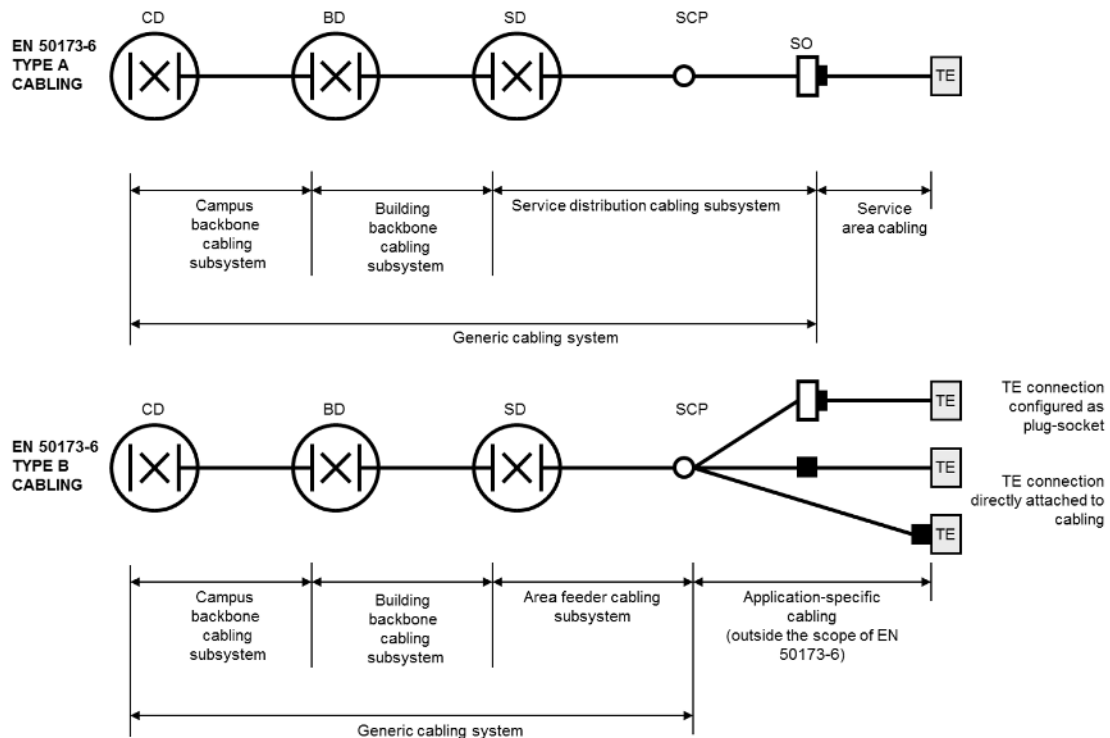

Figure 7 – Building service cabling subsystem according to EN 50173-6

5.2.5 Application-specific fixed cabling

In cases where data centre owners agree to the use of application-specific cabling because of advantages compared with generic cabling, those application-specific cabling systems shall have a fixed and structured infrastructure approach in accordance with the cabling subsystem architecture of EN 50173-5 (see Figure 5).

5.3 Structured cabling for other data centre spaces and application-specific structured cabling

5.3.1 General

The cabling infrastructures in a data centre shall be appropriate to provide networking and telecommunications capabilities in and between many of the dedicated data centre spaces. The cabling infrastructure between and within the data centre spaces other than the computer room space shall take one or more of the following forms:

- a) generic – structured cabling in accordance with EN 50173-2 for IT and network telecommunications (see 5.2.3);
- b) generic - structured cabling in accordance with EN 50173-6 for monitoring and control (see 5.2.4);
- c) application specific (see 5.3.2).

5.3.2 Application-specific cabling using a fixed infrastructure

In cases where data centre owners agree to the use of application-specific cabling because of advantages compared with generic cabling, those application-specific cabling systems shall have a fixed and structured infrastructure approach in accordance with the cabling subsystem architecture of EN 50173-2 (see Figure 6).

6 Availability design principles for telecommunications cabling infrastructure

EN 50600-1:2012, Annex A, gives guidance about design principles for availability. This standard uses the principles of:

- a) redundancy;
- b) maintainability;
- c) scalability / future proofness and
- d) simplicity.

as a basis for the design of:

- 1) the telecommunications cabling itself;
- 2) the telecommunications architecture;
- 3) associated pathways and spaces.

in order to achieve the desired Availability Class for the telecommunications infrastructure as described in Clause 6.

Redundancy within the networks of the data centre shall be implemented by means of the active equipment without the need for manual interaction. All redundancy implementations within the cabling (e.g. multi-path routing; Classes 3 and 4) are in support of that provided by active equipment.

7 Availability classification for telecommunications cabling infrastructure

7.1 General

This clause classifies the architecture and the redundancy concept of all telecommunications cabling infrastructures as it relates to the chosen overall Availability Class for facilities and infrastructures of the data centre according to EN 50600-1.

Table 1 defines the minimum requirements for all telecommunications cabling types in the different data centre spaces to achieve the chosen overall Availability Class of the data centre as defined by EN 50600-1. All defined Availability Classes for the different cabling types and spaces shall be met in order to achieve the chosen overall data centre Availability Class for facilities and infrastructures.

Table 1 – Telecommunication cabling Availability Classes per space architecture and overall data centre Availability Class for facilities and infrastructures

Data centre space	Cabling type	Overall data centre facilities and infrastructure - Availability Class 1	Overall data centre facilities and infrastructure - Availability Class 2	Overall data centre facilities and infrastructure - Availability Class 3	Overall data centre facilities and infrastructure - Availability Class 4
Computer room space	Inter-cabinets	7.2.1 Class 1	7.2.2 Class 2	7.2.3 Class 3	7.2.4 Class 4
	Intra-cabinets	7.2.1 Class 1	7.2.1 Class 1	7.2.1 Class 1	7.2.1 Class 1
	Adjacent cabinets	7.2.1 Class 1	7.2.1 Class 1	7.2.1 Class 1	7.2.1 Class 1
	Monitoring and Control	7.4	7.4	7.4	7.4
	Office style cabling	7.3	7.3	7.3	7.3
Control room space	Office style cabling	7.3	7.3	7.3	7.3
	Monitoring and Control	7.4	7.4	7.4	7.4
Other spaces	Office Style	7.3	7.3	7.3	7.3
	Monitoring and Control	7.4	7.4	7.4	7.4

7.2 Telecommunications cabling for the computer room

7.2.1 Cabling for Availability Class 1

A telecommunications cabling infrastructure for Availability Class 1 uses either a point-to-point connection (i.e. equipment cords) for the transmission channel (see Figure 8) or a fixed cabling infrastructure (see Figure 9) in a single-path configuration as shown in Figure 10.

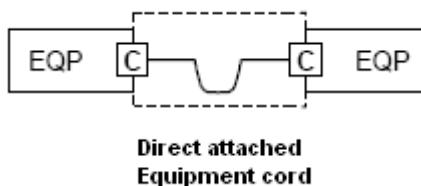

Figure 8 – Telecommunication cabling Class 1 using direct attached cords

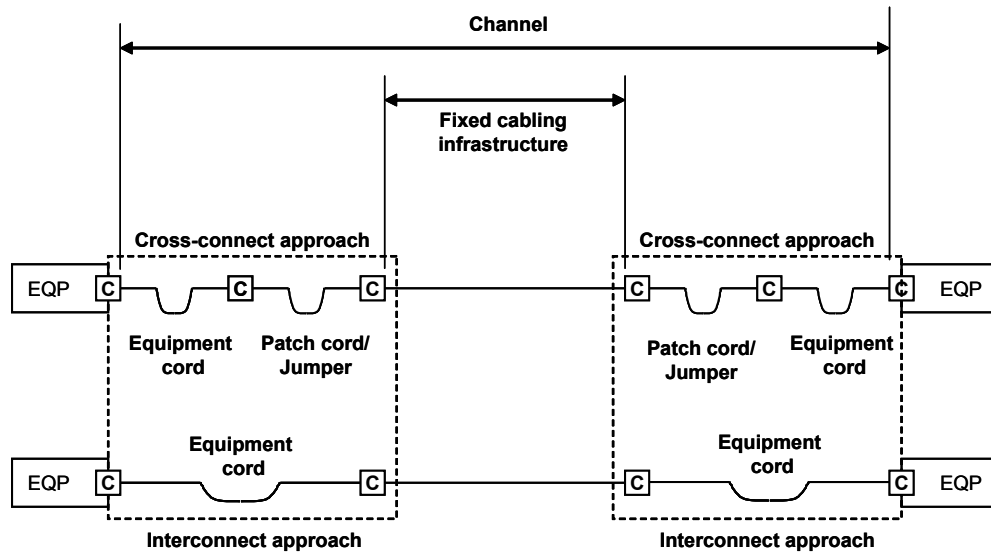

Figure 9 – Transmission channels (interconnect and cross-connect)

The point-to-point connections shall use pre-terminated cords and shall be restricted to local connections within the same cabinet or between adjacent cabinets, frames and racks.

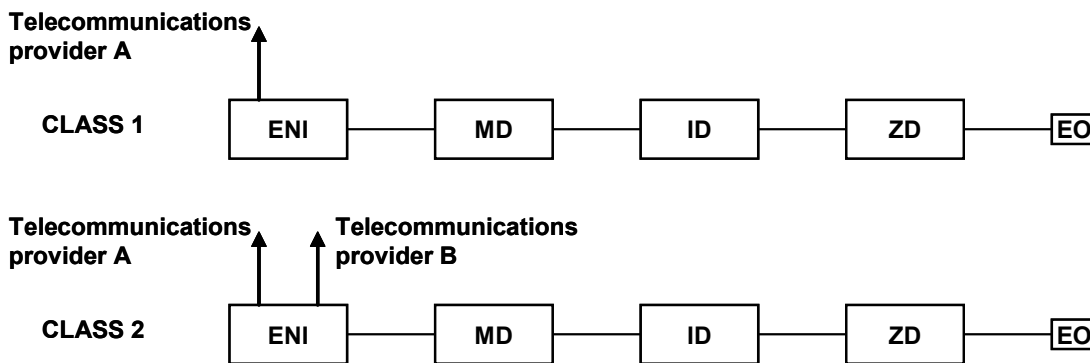

Figure 10 – ENI redundancy for Class 1 and 2

7.2.2 Cabling for Availability Class 2

A telecommunications cabling infrastructure for Availability Class 2 shall use a fixed cabling infrastructure (e.g. according to EN 50173-5 or application-specific) in cabling subsystems defined in EN 50173-5 for the transmission channel design (see Figure 9) with a single-path architecture with redundancy on the ENI as shown in Figure 10. The pathways for the telecommunications providers shall be designed according to Clause 8.

Furthermore, the following design criteria shall be met:

- the design shall be flexible and scalable to allow quick moves, adds and changes by using central and local patching/cross connect locations in MD, ID and ZD as shown in Figure 11;
- the patching/cross-connect cabinets/frames/racks used in MD and/or ID (CPL) and ZD (ZPL) shall offer rear cable management and side patch cord management. The design and selection of cross-connect cabinets/frames/racks shall take into consideration the maximum planned cabling capacity and required density inside the cabinets/frames/racks with the objective of minimising the disruption of airflow to active equipment. One possible and preferred way of achieving this functionality is to increase the width of the cabinets/frames/racks to offer more space for cable and patch cords which simplifies operations for moves, adds and changes.

- c) where it is intended to create channels from more than a single subsystem via cross-connects in distributors, the selection of media and component performance shall take into account the impact of the number of connections within, and the total length of, the channels in relation to the applications which are intended to be supported.

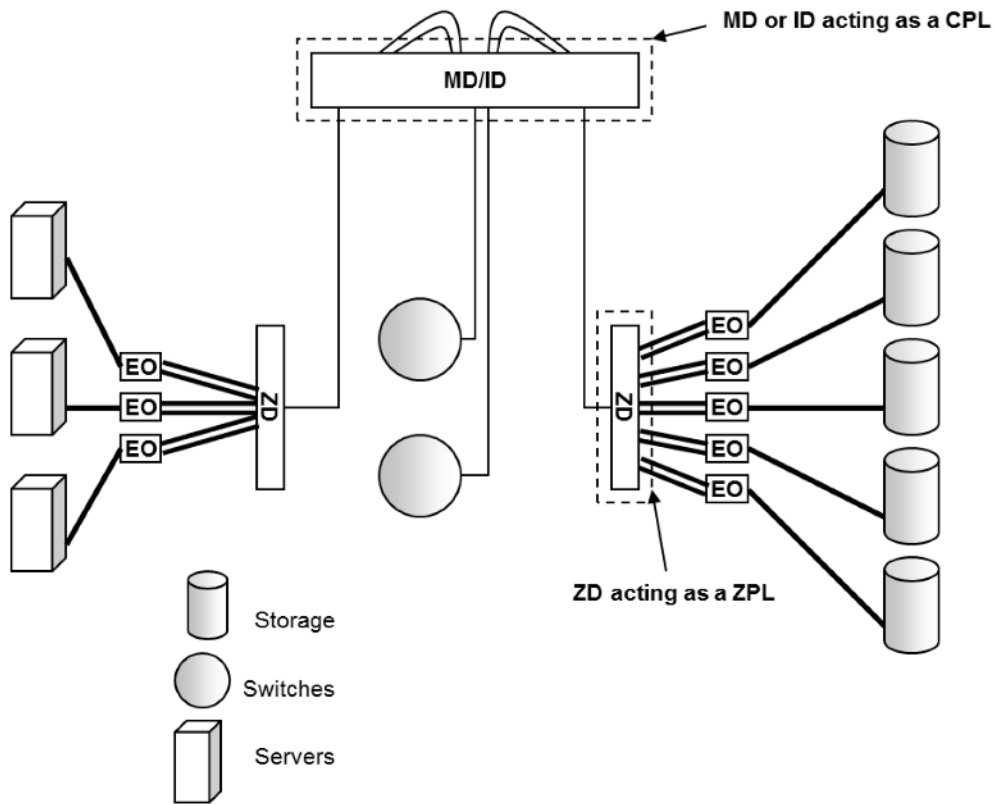

Figure 11 – Managing moves, adds and changes

7.2.3 Cabling for Availability Class 3

A telecommunications cabling infrastructure for Availability Class 3 shall use a fixed cabling infrastructure (e.g. according to EN 50173-5 or application-specific) in cabling subsystems defined in EN 50173-5 for the transmission channel design (see Figure 9) with a multi-path redundancy configuration using diverse physical pathways as shown in Figure 12. The pathways for the telecommunications providers shall be designed according to Clause 8.

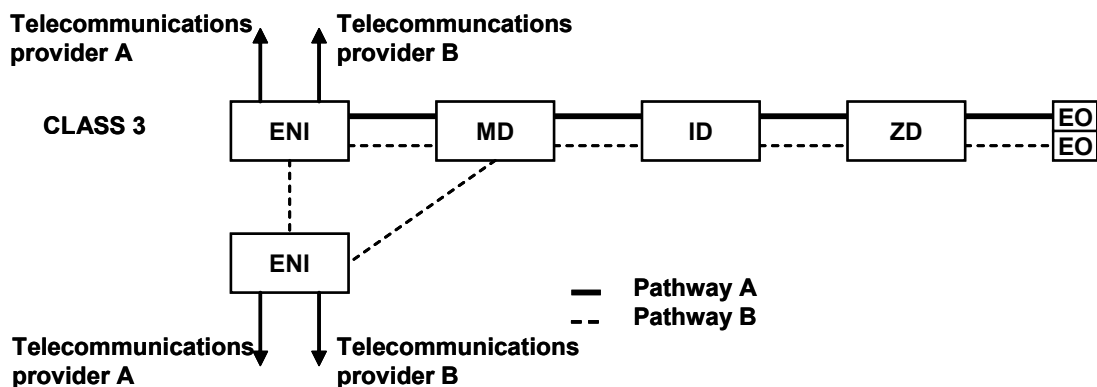

Figure 12 - Redundant multipath telecommunication cabling Class 3

Furthermore, the following design criteria shall be met:

- a) the design shall be flexible and scalable to allow quick moves, adds and changes by using central and local patching/cross connect locations in MD, ID and ZD as shown in Figure 11;
- b) the patching/cross-connect cabinets/frames/racks used in MD and/or ID (CPL) and ZD (ZPL) shall offer rear cable management and side patch cord management. The design and selection of cross-connect cabinets/frames/racks shall take into consideration the maximum planned cabling capacity and required density inside the cabinets/frames/racks with the objective of minimising the disruption of airflow to active equipment. The patch cord management inside the cabinets/frames/racks shall provide bend radius control. Additionally, the cabinet/frame/rack shall offer easy accessible and bend radius controlled slack storage for patch cords. One possible and preferred way of achieving this functionality is to increase the width of the cabinets/frames/racks to offer more space for cable and patch cords which simplifies operations for moves, adds and changes;
- c) where it is intended to create channels from more than a single subsystem via cross-connects in distributors, the selection of media and component performance shall take into account the impact of the number of connections within, and the total length of, the channels in relation to the applications which are intended to be supported;
- d) the cabling shall be routed within the data centre on appropriate pathway systems providing bend radius control (using additional fittings if not provided by the pathway system itself) and slack storage plus sufficient space for future expansions.

The use of pre-terminated cabling shall be considered for this class where:

- 1) on-site termination of cabling is impractical (e.g. field terminable connectors are not available);
- 2) operational constraints dictate that the time taken to install cabling shall be minimised (e.g. cabling needs to be in use as quickly as possible);
- 3) security concerns dictate that the presence in the data centre of third-party labour is minimised.

7.2.4 Cabling for Availability Class 4

A telecommunications cabling infrastructure for Availability Class 4 shall use a fixed cabling infrastructure (e.g. according to EN 50173-5 or application-specific) in cabling subsystems defined in EN 50173-5 for the transmission channel design (see Figure 9) with a multi-path redundancy configuration using diverse physical pathways and redundant distribution areas as shown in Figure 13. The pathways for the telecommunications providers shall be designed according to Clause 8.

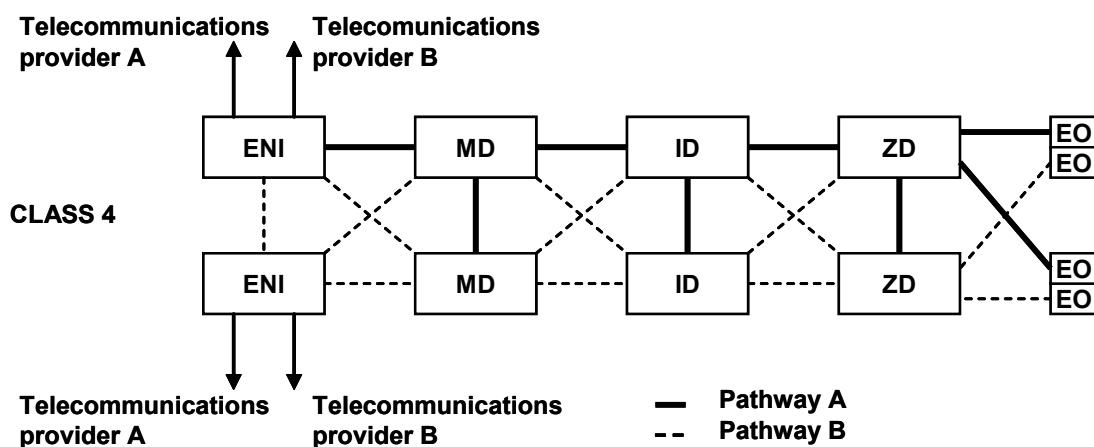

Figure 13 - Redundant multipath telecommunication cabling Class 4

Furthermore, the following design criteria shall be met:

- a) the design shall be flexible and scalable to allow quick moves, adds and changes by using central and local patching/cross connect locations in MD, ID and ZD as shown in Figure 11;
- b) the patching/cross-connect cabinets/frames/racks used in MD and/or ID (CPL) and ZD (ZPL) shall offer rear cable management and side patch cord management. The design and selection of cross-connect cabinets/frames/racks shall take into consideration the maximum planned cabling capacity and required density inside the cabinets/frames/racks with the objective of minimising the disruption of airflow to active equipment. The patch cord management inside the cabinets/frames/racks shall provide bend radius control. Additionally, the cabinet/frame/rack shall offer easy accessible and bend radius controlled slack storage for patch cords. One possible and preferred way of achieving this functionality is to increase the width of the cabinets/frames/racks to offer more space for cable and patch cords which simplifies operations for moves, adds and changes;
- c) where it is intended to create channels from more than a single subsystem via cross-connects in distributors, the selection of media and component performance shall take into account the impact of the number of connections within, and the total length of, the channels in relation to the applications which are intended to be supported;
- d) the cabling shall be routed within the data centre on appropriate pathway systems providing bend radius control (using additional fittings if not provided by the pathway system itself) and slack storage plus sufficient space for future expansions.

The use of pre-terminated cabling shall be considered for this class where:

- 1) on-site termination of cabling is impractical (e.g. field terminable connectors are not available);
- 2) operational constraints dictate that the time taken to install cabling shall be minimised (e.g. cabling needs to be in use as quickly as possible);
- 3) security concerns dictate that the presence in the data centre of third-party labour is minimised.

7.3 Telecommunications cabling for offices

A telecommunications cabling infrastructure shall use a fixed cabling infrastructure (i.e. according to EN 50173-2 or application-specific) in cabling subsystems in a single-path architecture. Any required redundancy should be provided on backbone level.

7.4 Telecommunications cabling for monitoring and control

A telecommunications cabling infrastructure shall use a fixed cabling infrastructure (i.e. according to EN 50173-6 or application-specific) in cabling subsystems in a single-path architecture.

Any required redundancy should be provided by the number of SOs provided throughout the data centre spaces.

8 Pathways and pathway systems for telecommunications cabling

8.1 General

Careful planning of telecommunications cabling routes, containment and enclosures is required to minimize adverse impact on efficient performance of air conditioning systems (see Clause 10).

The design requirements of this clause shall be implemented using the general and data centre specific requirements of EN 50174-2.

It should be noted that EN 50174-2 also contains recommendations which may assist in the design of a data centre telecommunications cabling infrastructure in accordance with this standard.

8.2 Pathways

8.2.1 External service pathways

8.2.1.1 Requirements

The Availability Class for the entire set of facilities and infrastructures of the data centre gives guidance to determine the need for:

- a) multiple service providers;
- b) multiple service provider premises (i.e. operator sites or central offices);
- c) diverse pathways from each of the service provider premises;
- d) multiple BEFs;
- e) multiple entrance rooms.

Clause 7 of this standard shall be used to determine and design the redundancy concept for the provisioning of external telecommunication services. Consideration shall be given to providing protection against failure in one or more parts of the cabling infrastructure by implementing:

- 1) multiple external network interfaces;
- 2) connections between external network interfaces;
- 3) multiple connections between external network interfaces and main and intermediate and zone distributors (MDs, IDs and ZDs);
- 4) multiple pathways between external network interfaces and main and intermediate and zone distributors (MDs, IDs and ZDs).

8.2.1.2 Recommendations

None.

8.2.2 Data centre pathways

8.2.2.1 Requirements

The design of pathways shall be co-ordinated with the designers of other services.

The requirements of EN 50600-2-1 for data centre pathways shall be applied.

The Availability Class for the entire set of facilities and infrastructures of the data centre gives guidance to determine the need for:

- a) multiple computer rooms and other spaces served by the computer room cabling;
- b) hierarchical redundant distribution areas within the computer room(s);
- c) segregation between redundant areas using different fire protection zones (fire compartmentation);
- d) independent pathways for each redundant area.

The selected Availability Class for the cabling in the computer room space (Table 1) shall be used to determine and design the data centre pathways. Consideration shall be given to providing protection against failure in one or more parts of the cabling infrastructure by implementing:

- 1) multiple MDs;
- 2) multiple ID's;
- 3) multiple ZDs;
- 4) multiple pathways between the MDs;
- 5) multiple pathways between the IDs;

- 6) multiple pathways between the ZDs;
- 7) multiple pathways between each MD and IDs;
- 8) multiple pathways between each MD and ZDs;
- 9) multiple pathways between each ID and ZDs;

8.2.2.2 General recommendations

Overhead telecommunications cabling may improve cooling efficiency and is recommended where ceiling heights permit because it can substantially reduce airflow losses due to airflow obstruction and turbulence caused by under floor cabling and cabling pathways.

8.3 Pathway systems

8.3.1 Requirements for data centre pathway systems

The design of pathway systems shall take into account the security requirements applicable to the data intended to be transmitted over the cabling (see EN 50600-2-5).

Pathway systems shall not be located under piping systems except for piping system used for cooling and fire extinguishing systems. This requirement also applies in other data centre spaces.

8.3.2 Access floor tile openings

The requirements of EN 50600-2-1 for access floor systems shall be applied.

8.3.3 Cable management systems

8.3.3.1 General

8.3.3.1.1 Requirements

In addition to the requirements of EN 50174-2, particular attention is drawn to the following:

- a) pathway systems shall have sufficient capacity to cater for the defined maximum capacity level;
- b) pathways systems shall have slack storage capabilities;
- c) pathways systems shall have bend radius control;
- d) pathway systems which do not provide continuous support (e.g. mesh, basket, hooks etc.) shall only be considered for non-vertical pathways where:
 - the cable to be accommodated is suitable for non-continuous support;
 - a list of acceptable combinations of pathway systems and cables shall be provided to the operator of the data centre;
 - mitigation is applied e.g. cable mat.

The design of pathway systems shall take into account the security requirements applicable to the data intended to be transmitted over the cabling (see EN 50600-2-5).

8.3.3.1.2 Recommendations

A list of acceptable combinations of pathway systems and cables should be provided to the operator of the data centre.

8.3.3.2 Requirements for under-floor systems

The requirements of EN 50600-2-1 for access floor systems shall be applied.

9 Cabinets and racks for the computer room space

9.1 General requirements

Cabinets and racks shall be selected to:

- a) provide a growth path for future technologies and data centre capacity demands;
- b) provide adequate cable management and bend radius functionality;
- c) provide and support adequate ventilation and cooling for the equipment it will house (see EN 50600-2-3).

Cabinets, racks and frames shall be provided with cable and cord management fittings.

9.2 Requirements for dimensions

The minimum width of the cabinets/racks used for CPL and ZPL shall be 0,8 m with a preference for a larger width (see Clause 7).

The minimum width of the cabinets/racks used for equipment shall cope with the current and future cable management requirements. A width of 0,8 m is recommended.

The minimum depth of the cabinets/racks used for equipment shall cope with the current and future equipment dimensions. A depth of 1,2 m is recommended.

Cabinets and racks shall not be located under piping systems (both for reasons of breakage or aggregation of condensation), except piping systems used for cooling and fire extinguishing systems. This requirement also applies to other data centre spaces. Blanking panels should be installed in unused cabinet positions in order to avoid mixing of hot and cold air.

9.3 Recommendations

The following cable management methods should be considered:

- a) for low density systems, there should be one rack unit of horizontal cable management for each rack unit of termination points;
- b) for high density applications, horizontal cable management systems that require rack units should be replaced with cable management without rack unit usage;
- c) the capacity of the vertical cable management within cabinets should be twice the cross-sectional area of the cables to be installed when the cabinets/racks are at full capacity;
- d) cabinets may require additional depth or width to provide adequate vertical cable management.

10 Documentation and quality plan

10.1 Requirements for documentation

The documentation of the installation shall be in accordance with EN 50174-1.

10.2 Recommendations for documentation

The identifier scheme for cabinets, frames and racks should use a grid co-ordinate system based on the access floor grid.

In cases where no access floor exists, a grid should be created by aisles and cabinets, frames and racks.

The identifier scheme should also identify the rack until location of the termination points/closures; see ISO/IEC TR 14763-2-1 for an example of one such scheme.

10.3 Requirements for the quality plan

The quality plan of the installation shall be in accordance with EN 50174-1. Additional requirements for the quality plan are under consideration.

11 Management and operation of the telecommunications cabling infrastructure

11.1 General

See EN 50600-3-1.

11.2 Automated infrastructure management systems

Automated infrastructure management (AIM) systems offering real time documentation and efficient management of the physical layer should be considered for availability and operational purposes. Ideally, the functionality of these systems should be integrated into existing or planned data centre management tools offering an overall infrastructure management.

11.3 Fibre optic cabling

In order to maintain optical fibre connection performance and in order to prevent optical fibre end-face damage to both the cabling and equipment, optical fibre end-faces shall be inspected for loose contamination which shall be removed prior to any connection being established. Inspection equipment is specified in EN 61300-3-35 and cleaning procedures, where necessary, are specified in IEC/TR 62627-01.

Annex A (normative)

Cabling design concepts

A.1 General

This annex presents design concepts for different equipment row configurations according to the Availability Classes 1 to 4 for telecommunications cabling.

Figure A.1 shows the keys used in Figures A.2 to A.9.

NOTE Interfaces are normally accommodated in patch panels.

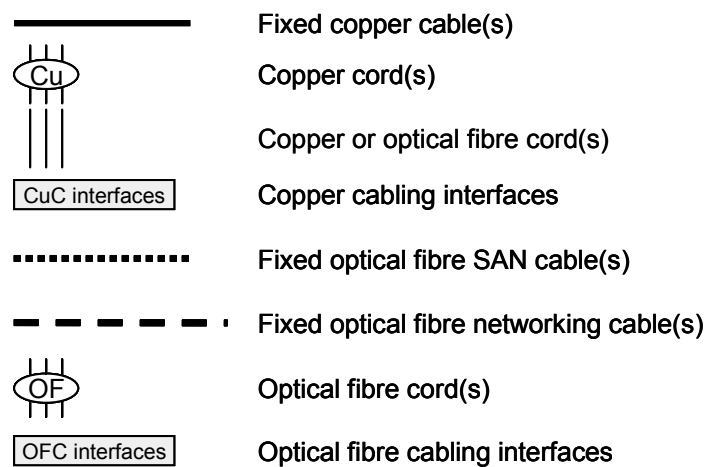

Figure A.1 – Symbols of network elements

Figures A.3 to A.9 show EOs of EN 50173-5 but the interfaces may also be interfaces to application-specific cabling.

A.2 Class 1 cabling concept

Figure A.2 illustrates a Class 1 cabling implementation using point-to-point cabling.

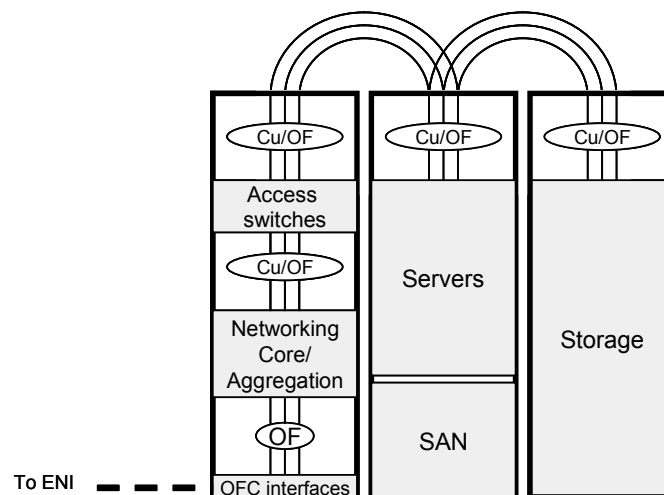

Figure A.2 – Example of a Class 1 cabling implementation

A.3 Class 2 cabling concepts

A.3.1 End of row and middle of row concepts

The end of row (EoR) and middle of row (MoR) networking concepts shall be implemented with Class 2 cabling according to Figure 9 and a CPL/ZPL configuration according to Figure 11.

These two concepts are the preferred concepts for server zones because future applications like 40GBase-T will be specified for EoR/MoR configuration.

A Class 2 cabling does not provide for redundancy.

For power budget reasons the SAN concept is a collapsed backbone.

Figure A.3 and Figure A.4 illustrate the EoR and MoR concepts.

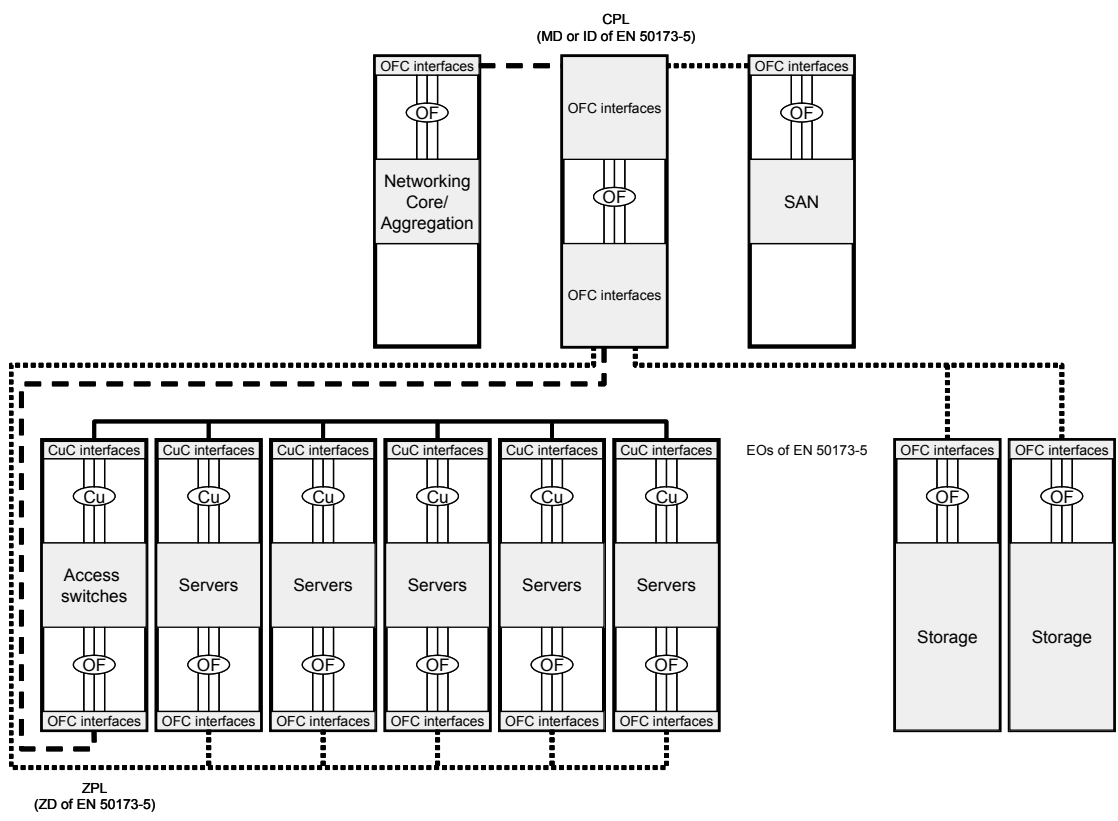

Figure A.3 – Example for Class 2 EoR cabling implementation

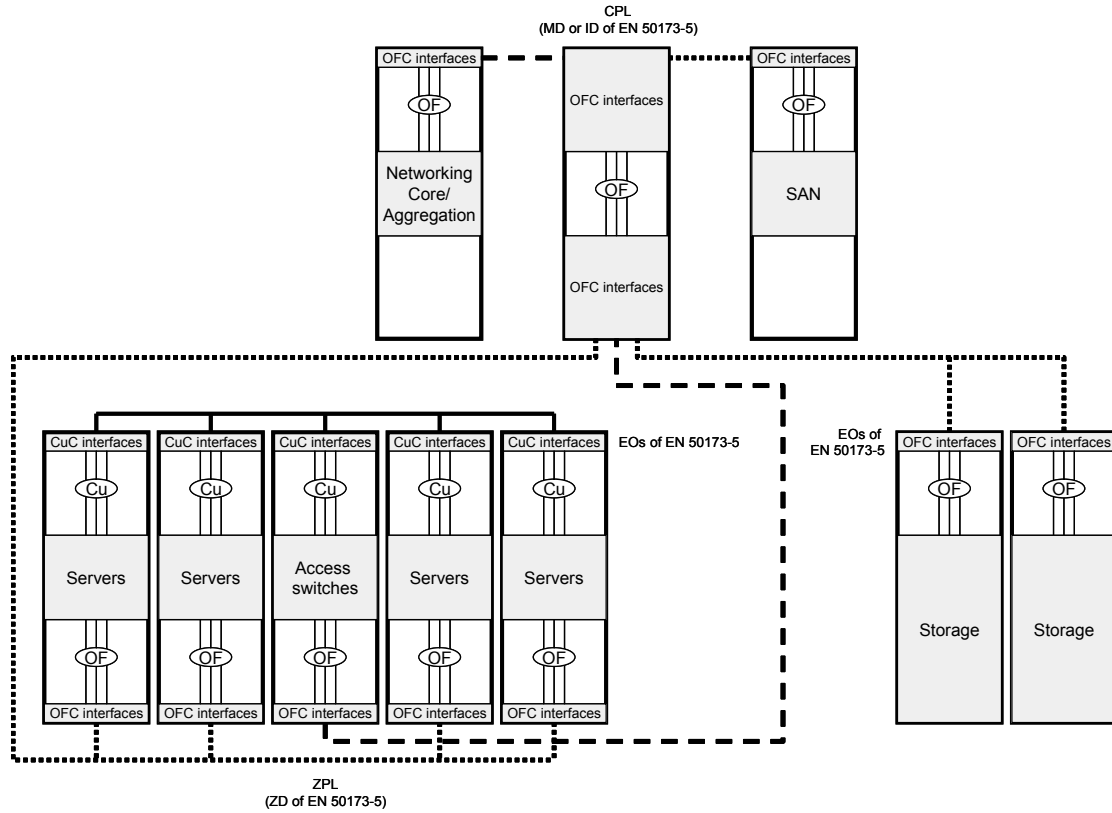

Figure A.4 – Example for Class 2 MoR cabling implementation

A.3.2 Top of rack concept

The top of rack (ToR) networking concept shall be implemented with Class 2 cabling according to Figure 9 and a CPL/ZPL configuration according to Figure 11.

A Class 2 cabling does not provide for redundancy.

For power budget reasons the SAN concept is a collapsed backbone.

Figure A.5 illustrates the ToR concept.

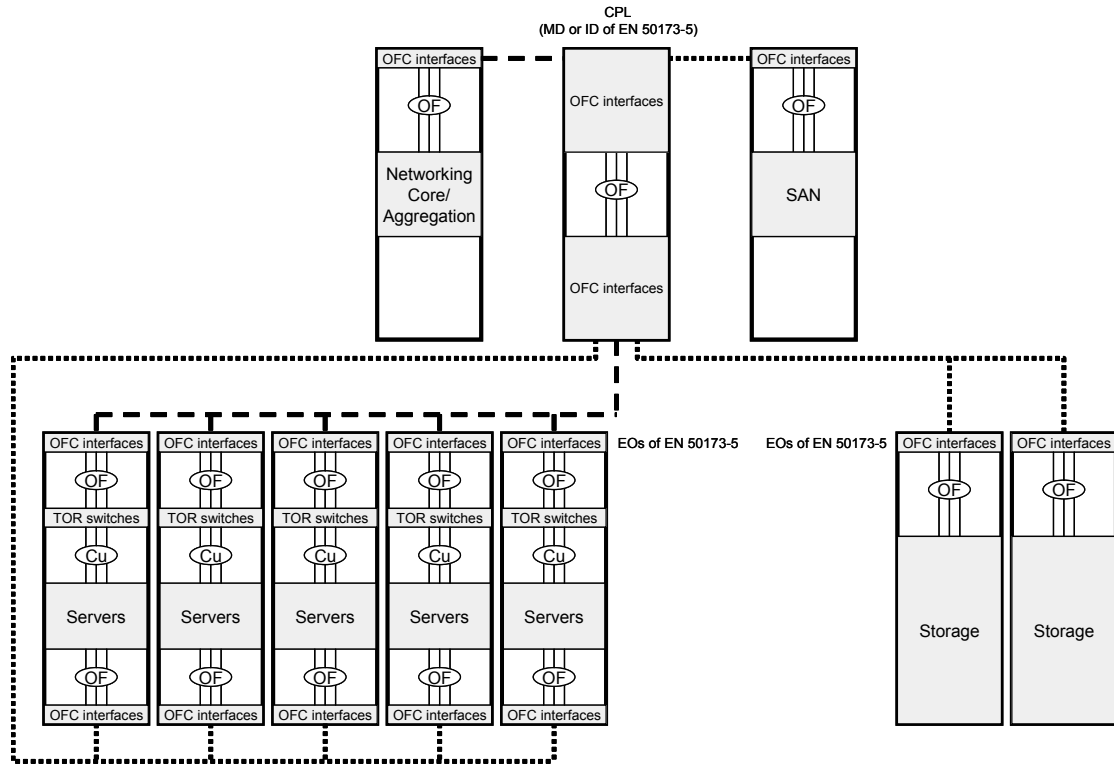

Figure A.5 – Example for Class 2 ToR cabling implementation

A.4 Class 3 cabling concepts

A.4.1 End of row and middle of row concepts

Redundant end of row (EoR) and middle of row (MoR) networking concepts shall be implemented with Class 3 cabling according to Figure 12 and a CPL/ZPL configuration according to Figure 11.

These two concepts are the preferred concepts for server zones because future applications like 40GBase-T will be specified for EoR/MoR configuration.

A Class 3 cabling provides redundancy with multiple pathways.

For power budget reasons the SAN concept is a collapsed backbone.

Figure A.6 illustrates the EoR concept. An MoR implementation is identical to the EoR implementation, except that the ZPL (i.e. the ZD of EN 50173-5) is located in the middle of the row.

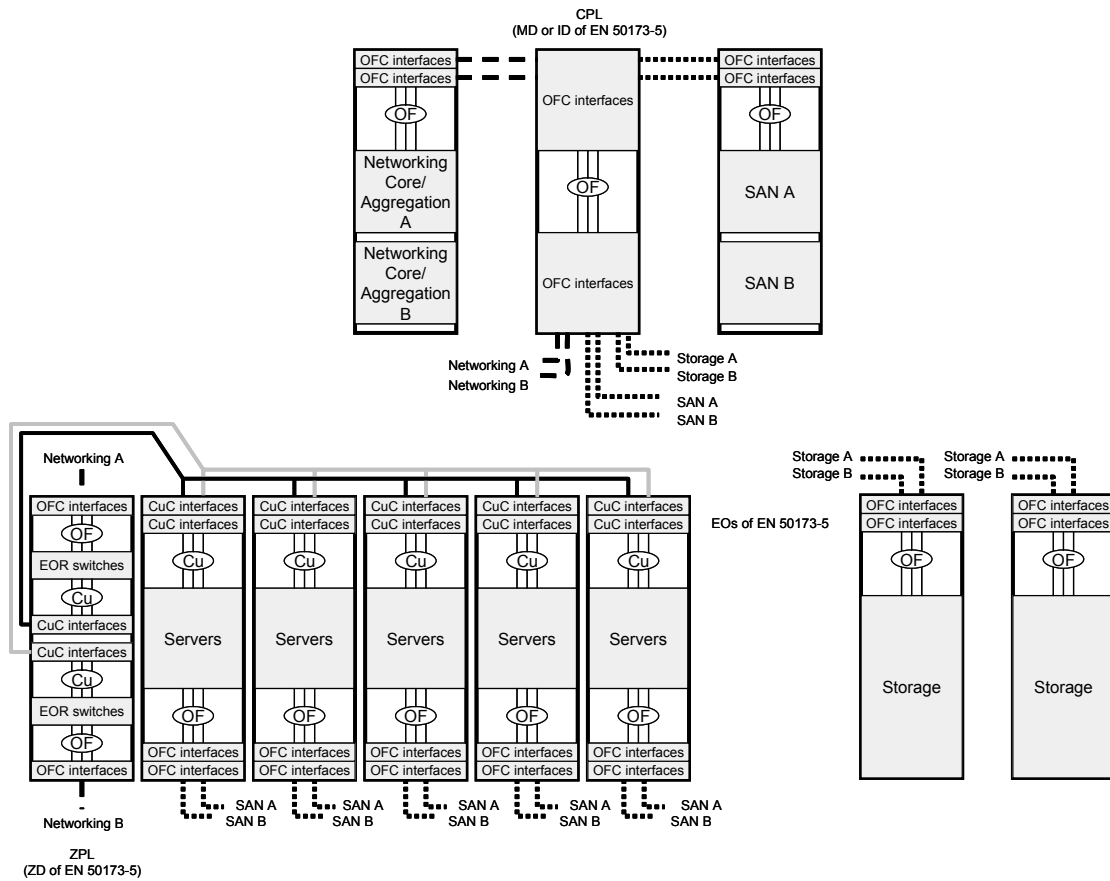

Figure A.6 – Example for Class 3 EoR cabling implementation

A.4.2 Top of rack concept

Redundant top of rack (ToR) networking concept shall be implemented with Class 3 cabling according to Figure 12 and a CPL/ZPL configuration according to Figure 11.

A Class 3 cabling provides redundancy with multiple pathways.

For power budget reasons the SAN concept is a collapsed backbone.

Figure A.7 illustrates the ToR concept.

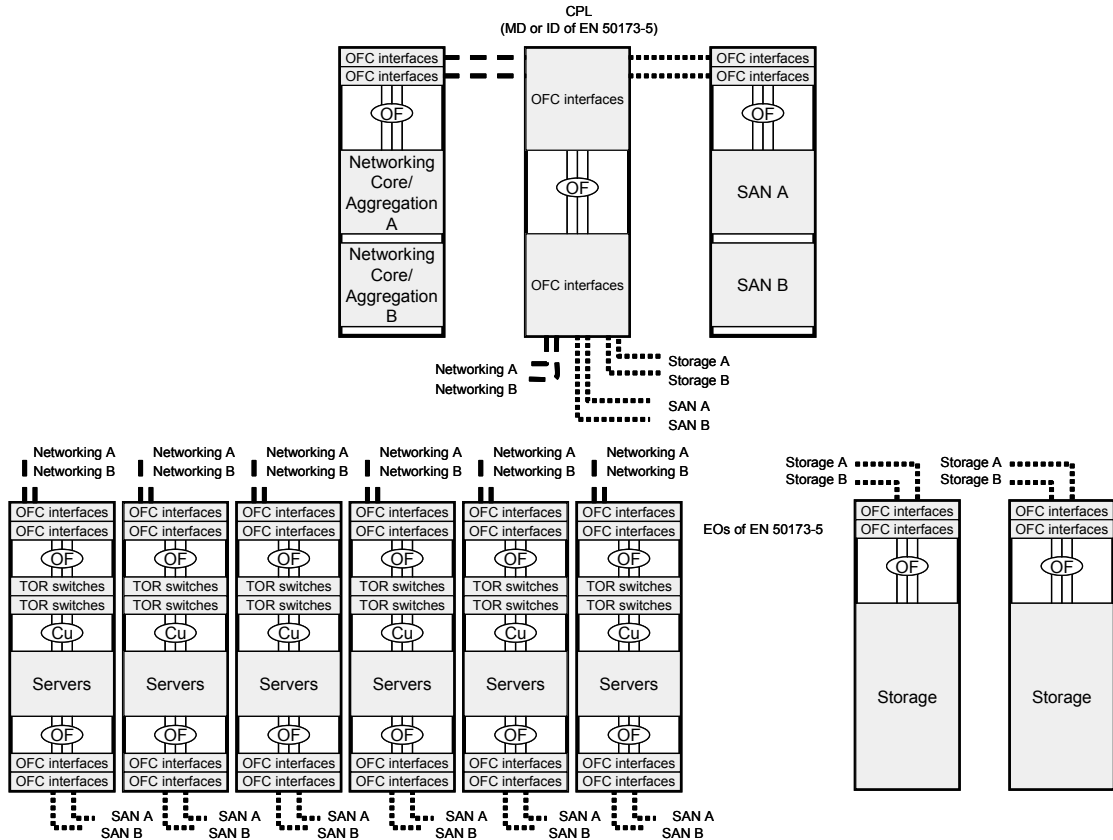

Figure A.7 – Example for Class 3 ToR cabling implementation

A.5 Class 4 cabling concepts

A.5.1 End of row and middle of row concepts

Redundant end of row (EoR) and middle of row (MoR) networking concepts shall be implemented with Class 4 cabling according to Figure 13 and a CPL/ZPL configuration according to Figure 11.

These two concepts are the preferred concepts for server zones because future applications like 40GBase-T will be specified for EoR/MoR configuration.

A Class 4 cabling provides redundancy with multiple pathways and redundant distribution areas.

For power budget reasons the SAN concept is a collapsed backbone.

Figure A.8 illustrates the EoR concept. An MoR implementation is identical to the EoR implementation, except that the ZPLs (i.e. the ZD of EN 50173-5) are located in the middle of the row.

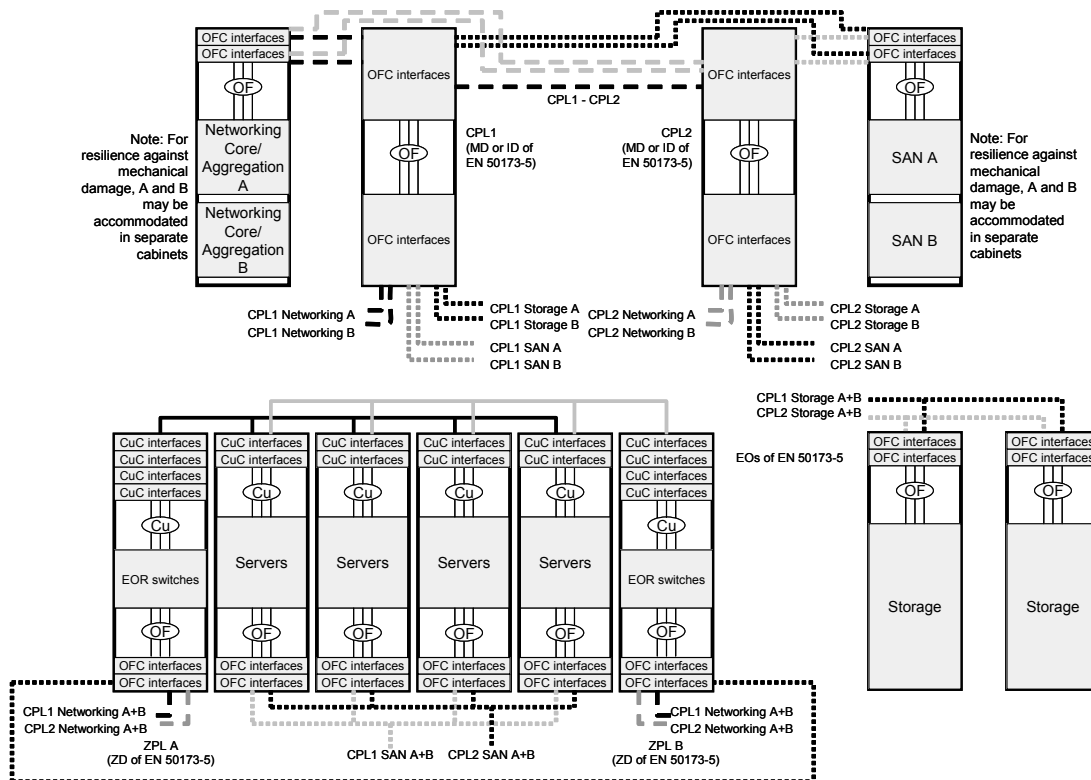

Figure A.8 – Example for Class 4 EoR cabling implementation

A.5.2 Top of rack concept

Redundant top of rack (ToR) networking concept shall be implemented with Class 4 cabling according to Figure 13 and a CPL/ZPL configuration according to Figure 11.

A Class 4 cabling provides redundancy with multiple pathways.

For power budget reasons the SAN concept is a collapsed backbone.

Figure A.9 illustrates the ToR concept.

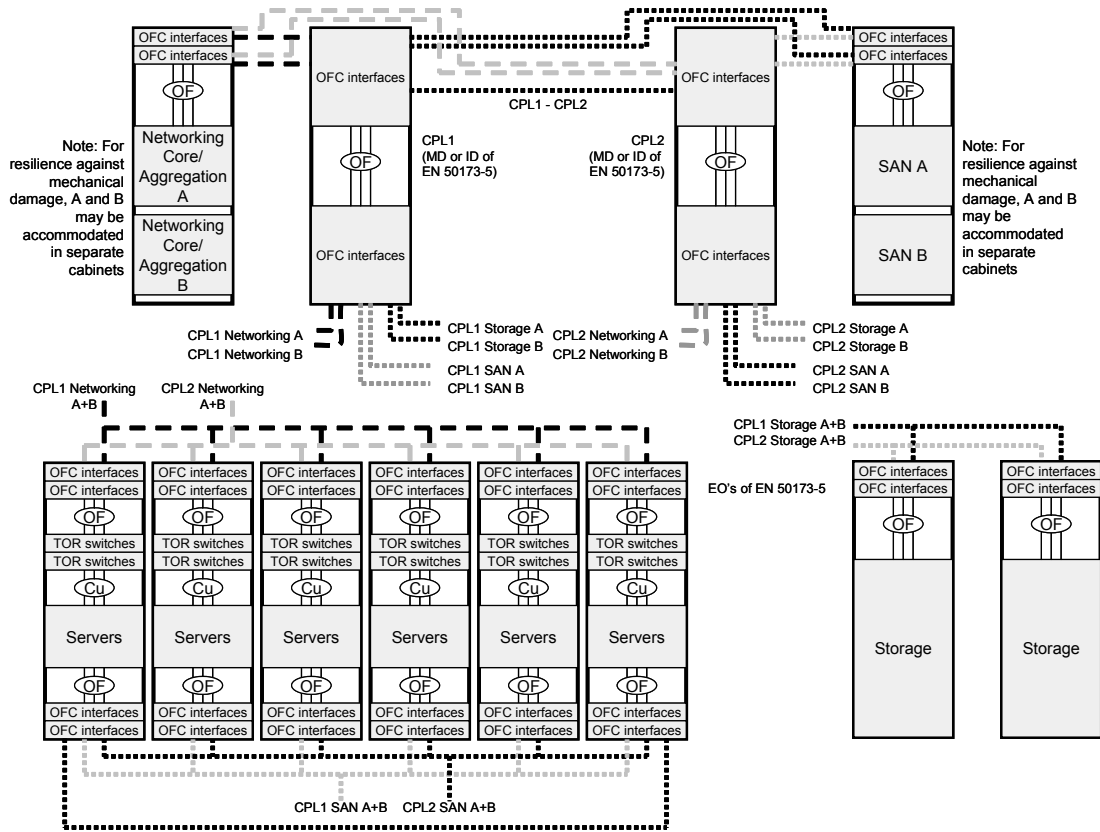

Figure A.9 – Example for Class 4 ToR cabling implementation

Annex B (informative)

Energy efficiency considerations for the telecommunications cabling infrastructure

Contribution to energy efficiency by the telecommunications infrastructure in a data centre can be achieved by:

- a) effective planning and installation of telecommunications cabling routes, containment and enclosures to minimize adverse impact on efficient performance of air conditioning systems;
- b) overhead distribution topology where cabling is placed away from cooling systems will improve air circulation and improve the energy efficiency of cooling systems;
- c) more efficient utilization of pathways and cable managers, which support higher density of equipment in racks and cabinets, as well as reduced pathway size can be achieved by using cables with smaller overall diameters;
- d) use of optical fibre cabling and associated equipment will reduce the energy consumption per port and is especially recommended for backbone connections where the potential use of PoE (Power over Ethernet) is limited;
- e) high performance cabling could enable lower complexity transmission equipment for future projects aimed specifically to improve energy efficiency. Transmission equipment designers should be consulted on parameters that will offer the greatest potential benefit for reducing power (e.g. lower signal loss and reflection, reduced and less variable impedance and improved internal and external noise immunity). In addition, 10GBASE-T, operating in short reach mode, can reduce power consumption by approximately 20 % per port when deployed over short length (30 m or less) Class E_A or higher cabling channels. In general, cabling topologies that reduce the cabling length will reduce material usage as well as improve energy efficiency when used with equipment that implements power back-off with reduced length.

More detailed information regarding energy efficiency considerations for data centre information technology and telecommunications infrastructure are provided in the following documents:

- EU Code of Conduct on Data Centres – Best Practices;
- ETSI TS 105 174-2-2.

Bibliography

EN 50600-2-2, *Information technology - Data centre facilities and infrastructures - Part 2-2: Power distribution*

EN 50600-2-5²⁾, *Information technology - Data centre facilities and infrastructures - Part 2-5: Security systems*

EN 61300-3-35, *Fibre optic interconnecting devices and passive components - Basic test and measurement procedures - Part 3-35: Examinations and measurements - Fibre optic connector endface visual and automated inspection (IEC 61300-3-35)*

IEC/TR 62627-01, *Fibre optic interconnecting devices and passive components - Part 01: Fibre optic connector cleaning methods*

ISO/IEC TR 14763-2-1, *Information technology – Implementation and operation of customer premises cabling – Part 2-1: Planning and installation – Identifiers within administration systems*

ETSI TS 105 174-2-2, *Access, Terminals, Transmission and Multiplexing (ATTM); Broadband Deployment – Energy Efficiency and Key Performance indicators; Part 2: Network sites; Sub-part 2: Data centres*

EU Code of Conduct on Data Centres – Best Practices

²⁾ Circulated for CENELEC Enquiry.

British Standards Institution (BSI)

BSI is the national body responsible for preparing British Standards and other standards-related publications, information and services.

BSI is incorporated by Royal Charter. British Standards and other standardization products are published by BSI Standards Limited.

About us

We bring together business, industry, government, consumers, innovators and others to shape their combined experience and expertise into standards-based solutions.

The knowledge embodied in our standards has been carefully assembled in a dependable format and refined through our open consultation process. Organizations of all sizes and across all sectors choose standards to help them achieve their goals.

Information on standards

We can provide you with the knowledge that your organization needs to succeed. Find out more about British Standards by visiting our website at bsigroup.com/standards or contacting our Customer Services team or Knowledge Centre.

Buying standards

You can buy and download PDF versions of BSI publications, including British and adopted European and international standards, through our website at bsigroup.com/shop, where hard copies can also be purchased.

If you need international and foreign standards from other Standards Development Organizations, hard copies can be ordered from our Customer Services team.

Subscriptions

Our range of subscription services are designed to make using standards easier for you. For further information on our subscription products go to bsigroup.com/subscriptions.

With **British Standards Online (BSOL)** you'll have instant access to over 55,000 British and adopted European and international standards from your desktop. It's available 24/7 and is refreshed daily so you'll always be up to date.

You can keep in touch with standards developments and receive substantial discounts on the purchase price of standards, both in single copy and subscription format, by becoming a **BSI Subscribing Member**.

PLUS is an updating service exclusive to BSI Subscribing Members. You will automatically receive the latest hard copy of your standards when they're revised or replaced.

To find out more about becoming a BSI Subscribing Member and the benefits of membership, please visit bsigroup.com/shop.

With a **Multi-User Network Licence (MUNL)** you are able to host standards publications on your intranet. Licences can cover as few or as many users as you wish. With updates supplied as soon as they're available, you can be sure your documentation is current. For further information, email bsmusales@bsigroup.com.

BSI Group Headquarters

389 Chiswick High Road London W4 4AL UK

Revisions

Our British Standards and other publications are updated by amendment or revision.

We continually improve the quality of our products and services to benefit your business. If you find an inaccuracy or ambiguity within a British Standard or other BSI publication please inform the Knowledge Centre.

Copyright

All the data, software and documentation set out in all British Standards and other BSI publications are the property of and copyrighted by BSI, or some person or entity that owns copyright in the information used (such as the international standardization bodies) and has formally licensed such information to BSI for commercial publication and use. Except as permitted under the Copyright, Designs and Patents Act 1988 no extract may be reproduced, stored in a retrieval system or transmitted in any form or by any means – electronic, photocopying, recording or otherwise – without prior written permission from BSI. Details and advice can be obtained from the Copyright & Licensing Department.

Useful Contacts:

Customer Services

Tel: +44 845 086 9001

Email (orders): orders@bsigroup.com

Email (enquiries): cservices@bsigroup.com

Subscriptions

Tel: +44 845 086 9001

Email: subscriptions@bsigroup.com

Knowledge Centre

Tel: +44 20 8996 7004

Email: knowledgecentre@bsigroup.com

Copyright & Licensing

Tel: +44 20 8996 7070

Email: copyright@bsigroup.com



...making excellence a habit.™