

BS EN 50557:2011



BSI Standards Publication

Requirements for automatic reclosing devices (ARDs) for circuit breakers-RCBOs-RCCBs for household and similar uses

bsi.

...making excellence a habit.™

National foreword

This British Standard is the UK implementation of EN 50557:2011.

The UK participation in its preparation was entrusted to Technical Committee PEL/23/1, Circuit breakers and similar equipment for household use.

A list of organizations represented on this committee can be obtained on request to its secretary.

This publication does not purport to include all the necessary provisions of a contract. Users are responsible for its correct application.

© The British Standards Institution 2012

ISBN 978 0 580 71224 1

ICS 29.120.50

Compliance with a British Standard cannot confer immunity from legal obligations.

This British Standard was published under the authority of the Standards Policy and Strategy Committee on 31 January 2012.

Amendments issued since publication

Date	Text affected
------	---------------

English version

Requirements for automatic reclosing devices (ARDs) for circuit breakers-RCBOs-RCCBs for household and similar uses

Prescriptions pour les dispositifs à refermeture automatique (DRA) pour disjoncteurs, ID et DD, pour usages domestiques et analogues

Automatisch wiedereinschaltende Einrichtungen für Leitungsschutzschalter sowie Fehlerstrom-Schutzschalter mit und ohne eingebautem Überstromschutz (RCBOs und RCCBs) für Hausinstallationen und für ähnliche Anwendungen (ARDs)

This European Standard was approved by CENELEC on 2011-07-19. CENELEC members are bound to comply with the CEN/CENELEC Internal Regulations which stipulate the conditions for giving this European Standard the status of a national standard without any alteration.

Up-to-date lists and bibliographical references concerning such national standards may be obtained on application to the CEN-CENELEC Management Centre or to any CENELEC member.

This European Standard exists in three official versions (English, French, German). A version in any other language made by translation under the responsibility of a CENELEC member into its own language and notified to the CEN-CENELEC Management Centre has the same status as the official versions.

CENELEC members are the national electrotechnical committees of Austria, Belgium, Bulgaria, Croatia, Cyprus, the Czech Republic, Denmark, Estonia, Finland, France, Germany, Greece, Hungary, Iceland, Ireland, Italy, Latvia, Lithuania, Luxembourg, Malta, the Netherlands, Norway, Poland, Portugal, Romania, Slovakia, Slovenia, Spain, Sweden, Switzerland and the United Kingdom.

CENELEC

European Committee for Electrotechnical Standardization

Comité Européen de Normalisation Electrotechnique

Europäisches Komitee für Elektrotechnische Normung

Management Centre: Avenue Marnix 17, B - 1000 Brussels

Contents

Foreword	5
Introduction	6
1 Scope	6
2 Normative references	6
3 Terms and definitions	8
4 Classification	10
4.1 According to the method of construction	10
4.2 According to the MPD	10
4.3 According to the type of assessment means	10
4.4 According to the safety means during the assessment	11
4.5 According to the range of ambient air temperature (only for ARD according to 4.2.2 and 4.2.3)	11
4.6 According to the connection to FE	11
4.7 According to maximum number of reclosing operations	11
4.8 According to mechanical interlock between MPD operating means and ARD enabling/disabling system	11
5 Characteristics	11
5.1 Summary of characteristics	11
5.2 Rated quantities	12
6 Marking and other product information	13
6.1 Standard marking	13
6.2 Instructions for assembly and operation	14
7 Standard conditions for operation in service	15
7.1 General	15
7.2 Conditions of installation	15
7.3 Pollution degree	15
8 Requirements for construction and operation	15
8.1 Mechanical design	15
8.2 Protection against electric shock	19
8.3 Dielectric properties and isolating capability	19
8.4 Temperature rise	20
8.5 Mechanical and electrical endurance	20
8.6 Performance at short-circuit currents	20
8.7 Resistance to mechanical shock and impact	20
8.8 Resistance to heat	20
8.9 Resistance to abnormal heat and to fire	20
8.10 Behaviour at low ambient air temperature	21
8.11 Operating characteristic	21
8.12 Assessment means for ARD according to 4.3.2	22
8.13 Safety in blocked condition	23
8.14 Test device	23
8.15 Ageing	23
8.16 Electromagnetic compatibility (EMC)	23
9 Tests	23
9.1 General	23
9.2 Test condition	23
9.3 Measurement of the reclosing time after the tripping of the MPD	24

9.4	Test of indelibility of marking	24
9.5	Verification of the non influence of the ARD on the correct operation of the MPD	24
9.6	Tests of creepage distances and clearances for electronic circuits (abnormal conditions)	26
9.7	Requirements for capacitors and specific resistors and inductors used in electronic circuits	28
9.8	Test of reliability of screws, current-carrying parts and connections	28
9.9	Test of reliability of terminals for external conductors	29
9.10	Verification of protection against electric shock	29
9.11	Test of dielectric properties and isolating capability	29
9.12	Temperature rise	30
9.13	Verification of the mechanical and electrical endurance – Verification of the reclosing system of the ARD	30
9.14	Short-circuit test	30
9.15	Resistance to mechanical shock and impact	31
9.16	Test of resistance to heat	31
9.17	Resistance to abnormal heat and to fire	32
9.18	Verification of the correct operation at low ambient air temperatures for RCCBs for use at temperatures between -25 °C and +40 °C	32
9.19	Verification of the operating characteristics	32
9.20	Verification of the safety during the assessment	33
9.21	Verification of the operation of the test device at the limits of rated voltage	34
9.22	Verification of ageing	34
9.23	Electromagnetic compatibility	35
Annex A	(informative) Classification of ARDs according to 4.3.1	43
Annex B	(informative) Classification of ARDs according to 4.3.2.1 a) and/or 4.3.2.2 a)	44
Annex C	(informative) Classification of ARDs according to 4.3.2.1 b) and/or 4.3.2.2 b)	45
Annex D	(normative) Number of samples for full test procedure	46
Annex E	(normative) Test sequences	47
Annex F	(informative) A-deviations	48
Annex ZZ	(informative) Coverage of Essential Requirements of EC Directives	49
Bibliography	50

Figures

Figure 1	– Minimum creepage distances and clearances measured in millimetres	37
Figure 2	– Minimum creepage distances and clearances as a function of peak value of operating voltage	38
Figure 3	– Verification of the reclosing subordinated to the measurements of the resistance to earth for ARD without functional earthing (9.19.1 a) – 9.19. 1 b) – 9.20.2)	39
Figure 4	– Verification of the reclosing subordinated to the measurements of the resistance to earth for ARD with functional earthing (9.19.1 a) – 9.19. 1 b) – 9.20.2)	40
Figure 5	– Verification of the reclosing subordinated to the measurements of the resistance between live parts (9.19.2 a) – 9.19.2 b))	41
Figure 6	– Test circuit for the verification of the maximum current in FE under normal condition	42
Figure A.1	– Classification of ARDs according to 4.3.1	43
Figure B.1	– Classification of ARDs according to 4.3.2.1 a) and/or 4.3.2.2 a)	44
Figure C.1	– Classification of ARDs according to 4.3.2.1 b) and/or 4.3.2.2 b)	45

Tables

Table 1 – Minimum admissible R_d values	12
Table 2 – Minimum clearances and creepage distances	18
Table 3 – Behaviour of the ARD in enable condition.....	22
Table 4 – Maximum permissible temperatures under abnormal conditions.....	27
Table 5 – Low frequency immunity test conditions.....	35
Table 6 – High-frequency immunity test conditions.....	36
Table 7 – Test conditions for electrostatic discharges	36
Table D.1 – Number of samples for full test procedure.....	46
Table D.2 – Additional tests for ARD already fully tested together with one kind of MPD	46
Table E.1 – Test sequences.....	47

Foreword

This document (EN 50557:2011) has been prepared by CLC/TC 23E "Circuit breakers and similar devices for household and similar applications".

The following dates are fixed:

- latest date by which this document has to be implemented at national level by publication of an identical national standard or by endorsement (dop) 2012-07-19
- latest date by which the national standards conflicting with this document have to be withdrawn (dow) 2014-07-19

Attention is drawn to the possibility that some of the elements of this document may be the subject of patent rights. CENELEC [and/or CEN] shall not be held responsible for identifying any or all such patent rights.

This document has been prepared under a mandate given to CENELEC by the European Commission and the European Free Trade Association, and supports essential requirements of EU Directive(s).

For the relationship with EU Directive(s) see informative Annex ZZ, which is an integral part of this document.

Introduction

Automatic Reclosing Devices are intended to reclose circuit-breakers-RCBOs-RCCBs after tripping in order to re-establish continuity of service.

1 Scope

This European Standard applies to Automatic Reclosing Devices (hereinafter referred to as “ARD”) for household and similar uses, for rated voltage not exceeding 440 V a.c. intended to be used in combination with circuit-breakers and/or RCCBs and/or RCBOs, and designed either for factory assembly or for assembly on site.

These devices are intended to reclose main protective devices (hereinafter referred to as “MPD”) such as circuit-breakers complying to EN 60898-1 and/or EN 60898-2, RCCBs complying to EN 61008-1 and RCBOs complying to EN 61009-1 after tripping of those devices in order to re-establish continuity of service.

In detail, this European Standard applies to the following types of ARD:

- ARD with assessment means, reclosing only if both the prospective line current and the prospective earth-fault current do not exceed given values;
- ARD with assessment means, reclosing only if the prospective line current does not exceed a given value;
- ARD with assessment means, reclosing only if the prospective earth-fault current does not exceed a given value;
- ARD that reclose without any assessment.

NOTE 1 The assessment cannot substitute the verifications required by HD 60364-6:2007.

NOTE 2 The requirements and tests for the assessment function in IT systems are under consideration.

This European Standard does not apply to ARDs with multiple settings adjustable by means accessible to the user in normal service.

This European Standard states:

- the terms and definitions used for ARD (Clause 3);
- the classification of ARD (Clause 4);
- the characteristics of ARD (Clause 5);
- the preferred values of the operating and influencing quantities (Clause 5);
- the marking and information to be provided for ARD (Clause 6);
- the standard conditions for installation and operation in service (Clause 7);
- the requirements for construction and operation (Clause 8);
- the list of minimum requirements to be tested (Clause 9).

2 Normative references

The following referenced documents are indispensable for the application of this document. For dated references, only the edition cited applies. For undated references, the latest edition of the referenced document (including any amendments) applies.

EN 55014-1:2006 + A1:2009, *Electromagnetic compatibility – Requirements for household appliances, electric tools and similar apparatus – Part 1: Emission* (CISPR 14-1:2005 + A1:2008)

EN 60065:2002 + A1:2006 + corr. Aug. 2007 + A11:2008 + A2:2010, *Audio, video and similar electronic apparatus – Safety requirements* (IEC 60065:2001, mod. + A1:2005, mod. + A2:2010, mod.)

EN 60112:2003 + A1:2009, *Method for the determination of the proof and the comparative tracking indices of solid insulating materials* (IEC 60112:2003 + A1:2009)

EN 60384-14 series, *Fixed capacitors for use in electronic equipment* (IEC 60384 series)

EN 60384-14:2005, *Fixed capacitors for use in electronic equipment – Part 14: Sectional specification – Fixed capacitors for electromagnetic interference suppression and connection to the supply mains* (IEC 60384-14:2005)

EN 60664-1:2007, *Insulation coordination for equipment within low-voltage systems – Part 1: Principles requirements and tests* (IEC 60664-1:2007)

EN 60664-3:2003 + A1:2010, *Insulation coordination for equipment within low-voltage systems – Part 3: Use of coating, potting or moulding for protection against pollution* (IEC 60664-3:2003 + A1:2010 + corr. Nov. 2010)

EN 60898-1:2003 + corr. Feb. 2004 + A1:2004 + A11:2005 + A12:2008, *Electrical accessories – Circuit-breakers for overcurrent protection for household and similar installations – Part 1: Circuit-breakers for a.c. operation* (IEC 60898-1:2002, mod. + A1:2002, mod.)

EN 60898-2:2006, *Electrical accessories – Circuit-breakers for overcurrent protection for household and similar installations – Part 2: Circuit-breakers for a.c. and d.c. operation* (IEC 60898-2:2000, mod. + A1:2003, mod.)

EN 60947-5-1:2004 + corr. Jul. 2005 + A1:2009, *Low-voltage switchgear and controlgear – Part 5-1: Control circuit devices and switching elements – Electromechanical control circuit devices* (IEC 60947-5-1:2003 + A1:2009)

EN 60950-1:2006 + A11:2009 + A1:2010, *Information technology equipment – Safety – Part 1: General requirements* (IEC 60950-1:2005, mod. + A1:2009, mod.)

EN 61008-1:2004 + A11:2007 + A12:2009, *Residual current operated circuit-breakers without integral overcurrent protection for household and similar uses (RCCBs) – Part 1: General rules* (IEC 61008-1:1996, mod. + A1:2002, mod.)

EN 61009-1:2004 + A11:2008 + A12:2009 + A13:2009, *Residual current operated circuit-breakers with integral overcurrent protection for household and similar uses (RCBOs) – Part 1: General rules* (IEC 61009-1:1996, mod. + A1:2002, mod. + corr. May 2003)

EN 61000-4-2:2009, *Electromagnetic compatibility (EMC) – Part 4-2: Testing and measurement techniques – Electrostatic discharge immunity test* (IEC 61000-4-2:2008)

EN 61000-4-3:2006 + A1:2008 + A2:2010, *Electromagnetic compatibility (EMC) – Part 4-3: Testing and measurement techniques – Radiated, radio-frequency, electromagnetic field immunity test* (IEC 61000-4-3:2006 + A1:2007 + A2:2010)

EN 61000-4-4:2004 + A1:2010, *Electromagnetic compatibility (EMC) – Part 4-4: Testing and measurement techniques – Electrical fast transient/burst immunity test* (IEC 61000-4-4:2004 + A1:2010)

EN 61000-4-5:2006, *Electromagnetic compatibility (EMC) – Part 4-5: Testing and measurement techniques – Surge immunity test* (IEC 61000-4-5:2005)

EN 61000-4-6:2009, *Electromagnetic compatibility (EMC) – Part 4-6: Testing and measurement techniques – Immunity to conducted disturbances, induced by radio-frequency fields* (IEC 61000-4-6:2008)

EN 61000-4-16:1998 + A1:2004 + A2:2011, *Electromagnetic compatibility (EMC) – Part 4-16: Testing and measurement techniques – Test for immunity to conducted, common mode disturbances in the frequency range 0 Hz to 150 kHz* (IEC 61000-4-16:1998 + A1:2001 + A2:2009)

EN 61189-2, *Test methods for electrical materials, printed boards and other interconnection structures and assemblies – Part 2: Test methods for materials for interconnection structures* (IEC 61189-2)

EN 61543:1995 + corr. Dec. 1997 + A11:2003 + A12:2005, *Residual current-operated protective devices (RCDs) for household and similar use Electromagnetic compatibility* (IEC 61543:1995 + A2:2005)

EN 61558 series, *Safety of power transformers, power supply units and similar products* (IEC 61558 series)

EN 62019, *Electrical accessories – Circuit-breakers and similar equipment for household use – Auxiliary contact units* (IEC 62019)

EN ISO 306:2004, *Plastics – Thermoplastic materials – Determination of Vicat softening temperature (VST)* (ISO 306:2004)

ISO 7000:2004, *Graphical symbols for use on equipment – Index and synopsis*

3 Terms and definitions

For the purposes of this document, the terms and definitions given in EN 60898-1:2003, EN 61008-1:2004, EN 61009-1:2004 and the following apply.

3.1

actuator

part of the actuating system to which an external force is applied when the ARD is installed as in normal use
[IEV 441-15-22, mod.]

NOTE The actuator may take the form of a handle, knob, push-button, roller, plunger, etc.

3.2

assessment using a method based on the limitation of the test current

type of assessment that is designed in such a way that, under normal operating in tripped and blocked conditions, the assessment is carried out by means of a non hazardous current flowing in the installation

NOTE The limit values of currents are specified in 8.12.3.

3.3

assessment using a method based on the limitation of the test voltage

type of assessment that is designed in such a way that, under normal operating in tripped and blocked conditions, the assessment is carried out by means of a non hazardous voltage applied at the installation by means of a transformer with a reinforced insulation between the primary and the secondary circuit

NOTE The limit values of voltage are specified in 8.12.2.

3.4

automatic reclosing

function intended to reclose, under specified conditions, the MPD after tripping

3.5

automatic reclosing device

ARD

electromechanical device intended to produce the automatic reclosing of the MPD to which is intended to be associated with

3.6

blocked condition

condition of the ARD for which the MPD is tripped and the ARD shall not reclose it automatically

NOTE This condition can be removed only by manual reset operation according to the manufacturer's instructions.

3.7

consecutive reclosing operations

number of consecutive reclosing operations that leads the ARD in blocked condition within a period of time

3.8

disabled (condition)

condition of the ARD for which automatic reclosing function is de-activated and MPD can never be automatically reclosed

3.9**earth fault current**

current flowing from the live parts of the installation to earth due to an insulation fault

3.10**enabled (condition)**

condition of the ARD for which automatic reclosing function is activated and MPD may be automatically reclosed (under specific condition)

3.11**functional earth**

FE

wire or terminal intended to be connected to the PE so as to provide a reference point to the ARD for assessment means

3.12**main protective device**

MPD

device to which the ARD is intended to be associated with and that recloses under specified conditions

NOTE The MPD is a circuit-breaker (EN 60898-1 and/or EN 60898-2) or a RCCB (EN 61008-1) or a RCBO (EN 61009-1).

3.13**non operating resistance between live parts**

maximum value of resistance between live parts, below which the automatic reclosing of the MPD is not permitted under specified conditions

3.14**non operating resistance to earth**

maximum value of resistance between live parts and earth, below which the automatic reclosing of the MPD is not permitted under specified conditions

3.15**operating resistance between live parts**

minimum value of resistance between live parts, for which the automatic reclosing of the MPD is ensured under specified conditions

3.16**operating resistance to earth**

minimum value of resistance between live parts and earth, for which the automatic reclosing of the MPD is ensured under specified conditions

3.17**prospective line current**

current likely to flow through live parts in case of reclosing of the MPD

3.18**prospective line current assessment**

assessment of the current likely to flow through

- each phase and neutral and
- each phase and each other phase and
- each phase and earth

after reclosing the MPD

NOTE This is generally achieved by evaluating the resistance.

3.19**prospective residual current**

current likely to flow from the live parts of the installation to earth in case of reclosing of the MPD

3.20

prospective residual current assessments

assessment of the residual current likely to flow through:

- phase and earth and
- neutral and earth.

after reclosing the MPD

NOTE This is generally achieved by evaluating the resistance.

3.21

reset time

period of time over that the ARD reset the counting of the consecutive reclosing operations

3.22

tripped condition

condition of ARD's for which the MPD has tripped and may reclose automatically under specified conditions

4 Classification

4.1 According to the method of construction

4.1.1 ARD assembled in factory by the manufacturer

NOTE This also includes built-in devices.

4.1.2 ARD assembled on site.

4.2 According to the MPD

4.2.1 ARD for circuit-breakers;

4.2.2 ARD for RCCBs;

4.2.3 ARD for RCBOs.

NOTE The same ARD may be designed for more than one MPD.

4.3 According to the type of assessment means

4.3.1 ARD without assessment means (see Annex A);

4.3.2 ARD with assessment means;

4.3.2.1 ARD with means of assessment of the prospective residual current.

- a) operation blocked after assessment of an excessive residual current in the installation (see Annex B);
- b) remains in tripped condition after the assessment of an excessive residual current in the installation (see Annex C).

4.3.2.2 ARD with means of assessment of the prospective line current

- a) operation blocked after assessment of an overcurrent in the installation (see Annex B);
- b) remains in tripped condition after the assessment of an overcurrent in the installation (see Annex C).

NOTE 1 The behaviour according to 4.3.2.1 b) and 4.3.2.2 b) is defined in the manufacturer's instructions.

NOTE 2 The same ARD may be designed with means for assessing both the prospective current according to 4.3.2.1 and 4.3.2.2.

4.4 According to the safety means during the assessment

4.4.1 ARD with assessment means operating by using a method based on the limitation of the test voltage;

4.4.2 ARD with assessment means operating by using a method based on the limitation of the test current.

4.5 According to the range of ambient air temperature (only for ARD according to 4.2.2 and 4.2.3)

4.5.1 ARD for use at ambient air temperatures between -5 °C and + 40 °C;

4.5.2 ARD for use at ambient air temperatures between -25 °C and + 40 °C.

4.6 According to the connection to FE

4.6.1 ARD with FE connection for assessment means;

4.6.2 ARD without FE connection.

4.7 According to maximum number of reclosing operations

4.7.1 ARD with maximum number of reclosing operations declared by manufacturer and lower than or equal to 3;

4.7.2 ARD with maximum number of reclosing operations declared by manufacturer and higher than 3.

4.8 According to mechanical interlock between MPD operating means and ARD enabling/disabling system

4.8.1 ARD with mechanical interlock between MPD operating means and ARD enabling/disabling system;

4.8.2 ARD without interlock between MPD operating means and ARD enabling/disabling system.

5 Characteristics

5.1 Summary of characteristics

The characteristics of the MPD standards and the following apply:

- protection against external influences;
- method of mounting;
- method of connection;
- value of rated operational voltage;
- value of rated frequency;
- values of operating and non operating rated resistance to earth, if applicable;
- values of operating and non operating rated resistance between live parts, if applicable;
- range of ambient air temperature.

5.2 Rated quantities

5.2.1 Rated voltage

Preferred values of rated voltage are: 230 V, 400 V.

5.2.2 Rated operational voltage (U_e)

The rated operational voltage (hereafter referred to as rated voltage) of an ARD is the value of voltage assigned by the manufacturer to which its performance is referred.

5.2.3 Rated frequency

The rated frequency of an ARD is the power frequency for which the ARD is designed and to which the values of the other characteristics correspond.

5.2.4 Rated non operating resistance to earth (R_{d0})

The R_{d0} value is stated by the manufacturer under the test conditions in this product standard.

5.2.5 Rated operating resistance to earth (R_d)

The R_d value is stated by the manufacturer under the test conditions in this product standard.

The R_d shall be rounded up to the last two more significant digits.

The minimum R_d value shall be not less than the values specified in Table 1.

Table 1 – Minimum admissible R_d values

I_{dn} A	R_d Ω
0,01	25 000
0,03	8 000
0,1	2 500
0,3	800
0,5	500
1	250

where I_{dn} is

- the value of the rated residual operating current I_{dn} of the associated RCD in case of ARDs classified according to 4.1.1, or
- the minimum rated residual operating current I_{dn} amongst all the associable RCDs in case of ARDs classified according to 4.1.2.

5.2.6 Rated operating resistance between live parts (R_{cc})

The R_{cc} value is stated by the manufacturer under the test conditions in this product standard.

The R_{cc} shall be rounded up to the last two more significant digits.

The minimum R_{cc} value shall be not less than:

$$R_{cc} \geq \frac{U_n}{I_{m\max}}$$


where

- U_n is the rated voltage;
- $I_{m\max}$ is the instantaneous tripping value of the associated MPD.

6 Marking and other product information

6.1 Standard marking

Each ARD shall be marked in a durable manner with all the following data:

- a) manufacturer's name or trade mark;
- b) type designation, catalogue number or serial number;
- c) wiring diagram, except if the connection mode is self evident;
- d) rated voltage(s) with the symbol \sim ;
- e) ARD or EN 50557;
- f) protection degree (only if different from IP20);
- g) for ARD classified according to 4.5.2, ambient air temperature with the symbol  (the value -25 included in the snowflake symbol according to ISO 7000:2004, Figure 0027).

For devices according to 4.1.2, the information of the ambient air temperature shall not be visible after assembly.

Moreover, the following markings shall be placed on the products or in the instruction sheets accompanying the product:

- h) the rated frequency (f_n) if different from 50 Hz;
- i) the rated non operating resistance between live parts and earth R_{d0} , if applicable;
- j) the rated operating resistance between live parts and earth R_d , if applicable;
- k) the rated non operating resistance between live parts R_{cc0} , if applicable;
- l) the rated operating resistance between live parts R_{cc} , if applicable;
- m) assembling method if applicable;
- n) earthing system in which the devices may be used;
- o) "Warning: before accessing active parts, disable the automatic reclosing function and switch off the main protective device" or other warning having the same meaning;
NOTE It is recommended that text shall be written in appropriated language(s).
- p) instructions about the reset of the ARD and the need for checking the MPD and the installation in case of blocked condition.

Information on how to reach the isolation of the installation shall be given in the instruction sheet accompanying the product.

The information under a) and b) shall be visible when the ARD is installed.

The information under m) is only applicable to products classified under 4.1.2.

The information under i), j), k) and l) are only applicable to products classified under 4.3.2.

The information under o) may be on the product or on a label to be installed on the board close to the ARD and in a position visible after that the ARD has been installed.

ARDs, classified according to 4.3.1, 4.3.2.1 a) or 4.3.2.2 a) with a reclosing time, measured according to 9.3, higher than 2 s shall be provided with indicating means showing the tripped condition of the MPD.

ARDs shall be provided with indicating means showing the blocked condition.

ARDs, classified according to 4.3.2.1 b) or 4.3.2.2 b) shall be provided with indicating means showing the tripped condition that is maintained after the fault detection in the installation.

The blocked condition and the tripped condition shall be clearly explained by the manufacturer (e.g. by means of an adhesive label or marking, or a light indicator) and instructions shall be given about how to reset the ARD and the need for checking the MPD and the installation in case of blocked condition.

Marking shall be indelible, easily legible and not be placed on screws, washers or other removable parts.

Compliance is checked by inspection and by the test of 9.4.

If auxiliary contacts are present, it is necessary to provide the following indication:

- rated operational current, rated operational voltage and utilisation category if the reference standard is the EN 62019; or
- rated current, rated voltage and opening gap, if the reference standard is the EN 60947-5-1.

For additional contacts intended for communication purpose, the reference according to EN 60950-1 shall be used.

For the ARD classified according to 4.6.1, the FE-wire or terminal shall be identified by the marking “FE”.

The following colours are not permitted for the FE-wire: green, yellow, blue and green-and-yellow.

The manufacturers instruction shall state that the FE should be connected directly to the PE, and looping in is not allowed.

The manufacturer shall provide the ARD power consumption data.

6.2 Instructions for assembly and operation

The manufacturer shall provide adequate instructions with the ARD.

In case of ARD classified according to 4.1.2, these instructions shall cover at least the following:

- reference to the type(s) and catalogue number(s), covering current and voltage ratings, number of poles, etc. of the MPD with which the ARD is designed to be assembled;
- method of assembly;
- need for checking operation after assembly to verify the mechanical operation;
- ambient air temperature of the combination (MPD+ARD).

Compliance is checked by inspection.

7 Standard conditions for operation in service

7.1 General

The ARD complying with this European Standard shall be capable of operating under the standard conditions given by the relevant MPD standard(s).

For the ARD+MPD, the relevant subclause of the MPD standard applies:

- a) EN 60898-1:2003 and EN 60898-2:2006, Clause 7, for ARDs classified according to 4.2.1 (circuit-breakers);
- b) EN 61008-1:2004, Clause 7, for ARD classified according to 4.2.2 (RCCBs);
- c) EN 61009-1:2004, Clause 7, for ARD classified according to 4.2.3 (RCBOs).

7.2 Conditions of installation

ARD shall be installed in accordance with the manufacturer's instructions.

ARD classified according to 4.1.2 shall only be installed together with the circuit-breakers, RCBOs and RCCBs declared by the manufacturer.

7.3 Pollution degree

ARDs to this European Standard are intended for environment with pollution degree 2, i.e.: normally, only non-conductive pollution occurs; occasionally, however, a temporary conductivity caused by condensation may be expected.

8 Requirements for construction and operation

8.1 Mechanical design

8.1.1 General

ARD shall be so designed and constructed that, in normal use when it is assembled with the MPD, their individual and combined performance is reliable and without danger to the user or surrounding.

ARD shall not impair safety characteristics and functions of the associated MPD.

In case of ARD classified according to 4.1.2, this device and the MPD shall be of the same manufacturer.

Compliance is checked by carrying out all the relevant tests specified.

ARD may be provided with a communication interface.

Test requirements are under consideration.

ARD shall be assembled only with main MPDs having an higher or equal range of ambient air temperature (see 4.5).

8.1.2 Mechanism

8.1.2.1 The ARD shall be so designed and constructed not to change the functional characteristic of the MPD.

Compliance is checked by inspection and by the test of 9.5.1.

8.1.2.2 The ARD and the MPD shall be associated in a proper way and the association shall be made in such way to avoid uncorrected matching.

Compliance is checked by inspection and with information detailed in 6.2.

8.1.2.3 For devices according to 4.8.1, it shall not be possible to enable the ARD if the MPD has been previously manually opened by the actuator.

It is permitted that the enabling system of the ARD may also cause the closing of the MPD during the same manual operation.

Compliance is checked by visual inspection and test of 9.5.2.

8.1.2.4 The ARD shall be provided with an enabling and disabling system.

The enabling and disabling system shall be manufactured in such a way that it can be directly operated by the user or by means of a tool of common usage.

The enabling and disabling system shall be able to correctly operate for a suitable number of operating cycles.

Compliance is checked by visual inspection and test of 9.5.3

8.1.2.5 Manual opening of the MPD shall be possible at every time.

This condition is considered as fulfilled if the manual opening is not possible without the disabling of the ARD.

For devices according to 4.8.1, if the ARD is enabled, manual opening of the MPD using the actuator shall always disable the automatic reclosing.

Compliance is checked by inspection and by the test of 9.5.2.

For devices according to 4.8.2, enabling/disabling of ARD shall be obtained by a separate enabling/disabling means. The enabled condition shall be clearly indicated (e.g. light indicator, mechanical indicator...).

Compliance is checked by inspection.

8.1.2.6 When the ARD is disabled:

- a) the MPD shall operate independently from the ARD, in particular it shall be possible to activate the test device, if any;
- b) It shall be possible to see the symbol O when the contacts of the MPD are in isolating condition.

Compliance to the point a) is checked by manual test.

Compliance to the point b) is checked by visual inspection and the dielectric tests according to 9.11 and the measurement of the creepage and clearances distances as requested in the point 1) of the Table 2.

8.1.2.7 For devices according to 4.8.1, when the ARD is enabled:

- a) it shall not be possible to see on the MPD the symbol O which shows the position of the contacts;
- b) It shall be possible to activate the test device with the exception of ARD with a reclosing time higher than 3 s where it is not accepted;
- c) the marking stated in the reference standard of the MPD shall be visible with the exception of the symbol O as stated in a).

NOTE Attention should be paid to keep visible important safety information or instructions after assembly in case of covers or handles.

Compliance to points a) and c) is checked by visual inspection.

For devices according to 4.8.2, the enabled condition shall be clearly indicated (e.g. light indicator, mechanical indicator, ...).

Compliance is checked by visual inspection.

8.1.2.8 ARD shall never perform a number of consecutive reclosing operation greater than those declared by the manufacturer within its reset time.

The reset time (see 3.21) shall not be less than 5 s.

For devices according to 4.7.1, the maximum number of operation shall not be greater than 3.

Compliance is checked by the test of 9.5.4.

For devices according to 4.7.2, the maximum number of operation shall be declared by manufacturer.

Compliance is checked by the test of 9.5.4.

8.1.3 Clearances and creepage distances

The minimum required clearances and creepage distances are given in Table 2 which is based on the ARD being designed for operating in an environment with pollution degree 2. However, the clearances of items 2 and 4 may be reduced provided that the tests at rated impulse voltage are withstood.

The values of Table 2 shall be verified for the ARD and the interface with the MPD.

The insulating materials are classified into material groups on the basis of their comparative tracking index (CTI) according to EN 60664-1:2007, 4.8.1.2 and 4.8.1.3.

8.1.4 Clearances and creepage distances for electronic circuits connected between live parts or between live parts and the earth

For electronic circuits connected between live parts, or between live parts and the earth circuit when the contacts are in the closed position, the verification of the clearances and creepage distances is replaced by the tests of 9.6 and 9.7.

Table 2 – Minimum clearances and creepage distances

All values in mm

Description	Minimum clearances		Minimum creepage distances ^{a, b}											
			Group IIIa ^c (175 V ≤ CTI < 400 V) ^d				Group II (400 V ≤ CTI < 600 V) ^d				Group I (600 V ≤ CTI) ^d			
	Rated voltage		Working voltage ^a											
	230 V	400 V	> 25 V ≤ 50 V ⁱ	120 V	250 V	400 V	> 25 V ≤ 50 V ⁱ	120 V	250 V	400 V	> 25 V ≤ 50 V ⁱ	120 V	250 V	400 V
1 Between live parts that are separated when the ARD is in the isolation condition	4,0	4,0	1,2	2,0	4,0	4,0	0,9	2,0	4,0	4,0	0,6	2,0	4,0	4,0
2 Between live parts of different polarity ^{f g}	3,0	3,0	1,2	1,5	3,0	4,0	0,9	1,5	3,0	3,0	0,6	1,5	3,0	3,0
3 Between circuits supplied from different sources, one of which being PELV or SELV ^h	6,0	8,0		3,0	6,0	8,0		3,0	6,0	8,0		3,0	6,0	8,0
			Rated voltage											
			230 V – 400 V				230 V – 400 V				230 V – 400 V			
4 Between live parts and - accessible surfaces of operating means - screws or other means for fixing covers which have to be removed when mounting the ARD - surface on which the ARD is mounted ⁱ - screws or other means for fixing the ARD ⁱ - metal covers or boxes ⁱ - other accessible metal parts ^j	3,0		4,0				3,0				3,0			

NOTE 1 The values given for 400 V are also valid for 440 V.

NOTE 2 The parts of the neutral path, if any, are considered to be live parts.

^a Interpolation is allowed in determining creepage distances corresponding to voltage values intermediate to those listed as working voltage. For determination of creepage distances, see Annex D.

^b Creepage distances cannot be less than the associated clearances.

^c For material group IIIb (100 V ≤ CTI < 175 V), the values for material group IIIa multiplied by 1,6 apply.

^d See EN 60112.

^e For working voltages up to and including 25 V, reference may be made to EN 60664-1.

^f For auxiliary, control and communications contacts, the values are given in the relevant standard.

^g This applies also to clearance and creepage distances between live parts of different polarity of the ARD and equipments mounted close to it.

^h To cover all different voltages including ELV in an auxiliary contact.

ⁱ The values are doubled if clearances and creepage distances between live parts of the device and the metallic screen or the surface on which the ARD is mounted are not dependent on the design of the ARD only, so that they can be reduced when the ARD is mounted in the most unfavourable condition.

^j Including a metal foil in contact with the surfaces of insulating material which that are accessible after installation as for normal use. The foil is pushed into corners, grooves, etc., by means of a straight unjointed test finger according to 9.6 (see Figure 1).

8.1.5 Screws, current-carrying parts and connections

For the ARD+MPD, the relevant subclause of the MPD standard applies:

- a) EN 60898-1:2003 and EN 60898-2:2006, 8.1.4, for ARD classified according to 4.2.1 (circuit-breakers);
- b) EN 61008-1:2004, 8.1.4, for ARD classified according to 4.2.2 (RCCBs);
- c) EN 61009-1:2004, 8.1.4, for ARD classified according to 4.2.3 (RCBOs).

These requirements are not applicable to the screws, current-carrying parts and connection of the MPD when they are intended for the connection to the ARD by means of conductors having a cross-sectional area identical to that stated in EN 61008-1:2004, Table 4, or EN 60898-1:2003, Table 5, or EN 61009-1:2004, Table 6.

Compliance is checked by the tests of 9.8.

8.1.6 Terminals for external conductors

For the ARD+MPD, the relevant subclause of the MPD standard applies:

- a) EN 60898-1:2003 and EN 60898-2:2006, 8.1.5, for ARD classified according to 4.2.1 (circuit-breakers);
- b) EN 61008-1:2004, 8.1.5, for ARD classified according to 4.2.2 (RCCBs);
- c) EN 61009-1:2004, 8.1.5, for ARD classified according to 4.2.3 (RCBOs).

These requirements are not applicable to terminals for external conductors of the MPD when they are intended for the connection to the ARD by means of conductors having a cross-sectional area identical to that stated in EN 61008-1:2004, Table 4, or EN 60898-1:2003, Table 5, or EN 61009-1:2004, Table 6.

If types or sizes of terminals are used, which are not considered in the MPD standard a), b) or c), generic standards for terminals shall apply (for example piercing terminals according to EN 60998-2-3).

The range of nominal cross-section for wires clamped to the FE terminal, if any, shall be between 1 mm² and 2,5 mm².

Compliance is checked by the tests of 9.9.

In case of ARD classified according to 4.1.2, if supply cables to be associated to the MPD are provided, suitable indications for preventing wrong connections shall be given.

NOTE This requirement is considered to be met by the colours of the supply conductors of the ARD and the installation instructions which accompany the device (see Clause 6, n).

Compliance is checked by inspection.

8.2 Protection against electric shock

For the ARD+MPD, the relevant subclause of the MPD standard applies:

- a) EN 60898-1:2003 and EN 60898-2:2006, 8.2, for ARD classified according to 4.2.1 (circuit-breakers);
- b) EN 61008-1:2004, 8.2, for ARD classified according to 4.2.2 (RCCBs);
- c) EN 61009-1:2004, 8.2, for ARD classified according to 4.2.3 (RCBOs).

Compliance is checked by the tests of 9.10.

8.3 Dielectric properties and isolating capability

The ARD+MPD shall not influence the suitability for isolation of the MPD.

Compliance is checked by the tests of 9.11.

8.4 Temperature rise

For the ARD+MPD, the corresponding subclause of the MPD standard applies:

- a) EN 60898-1:2003 and EN 60898-2:2006, 8.4, for ARD classified according to 4.2.1 (circuit-breakers);
- b) EN 61008-1:2004, 8.4, for ARD classified according to 4.2.2 (RCCBs);
- c) EN 61009-1:2004, 8.4, for ARD classified according to 4.2.3 (RCBOs).

Compliance is checked by the tests of 9.12

8.5 Mechanical and electrical endurance

ARD+MPD shall be capable of performing an adequate number of cycles of operations.

Compliance is checked by the tests of 9.13.

8.6 Performance at short-circuit currents

Performances in case of short circuit currents of the MPD shall not be influenced by the ARD.

Performances of the ARD shall not be influenced by short circuits occurring in the installation.

Compliance is checked by the tests of 9.14.

8.7 Resistance to mechanical shock and impact

The relevant subclause of the MPD standard applies:

- a) EN 60898-1:2003 and EN 60898-2:2006, 8.9, for ARD classified according to 4.2.1 (circuit-breakers);
- b) EN 61008-1:2004, 8.8, for ARD classified according to 4.2.2 (RCCBs);
- c) EN 61009-1:2004, 8.8, for ARD classified according to 4.2.3 (RCBOs).

Compliance is checked by the tests of 9.15.

8.8 Resistance to heat

The relevant subclause of the MPD standard applies:

- a) EN 60898-1:2003 and EN 60898-2:2006, 8.10, for ARD classified according to 4.2.1 (circuit-breakers);
- b) EN 61008-1:2004, 8.9, for ARD classified according to 4.2.2 (RCCBs);
- c) EN 61009-1:2004, 8.9, for ARD classified according to 4.2.3 (RCBOs).

Compliance is checked by the tests of 9.16.

8.9 Resistance to abnormal heat and to fire

The relevant subclause of the MPD standard applies:

- a) EN 60898-1:2003 and EN 60898-2:2006, 8.11, for ARD classified according to 4.2.1 (circuit-breakers);
- b) EN 61008-1:2004, 8.10, for ARD classified according to 4.2.2 (RCCBs);
- c) EN 61009-1:2004, 8.10, for ARD classified according to 4.2.3 (RCBOs).

Compliance is checked by the tests of 9.17.

8.10 Behaviour at low ambient air temperature

ARD classified according to 4.2.2 and 4.2.3 for use in the range of -25 °C to +40 °C shall operate reliably at low temperatures.

For the ARD+MPD, the relevant subclauses of the MPD standard applies:

- a) EN 61008-1:2004, 8.Z1, for ARD classified according to 4.2.2 (RCCBs);
- b) EN 61009-1:2004, 8.Z1, for ARD classified according to 4.2.3 (RCBOs).

Compliance is checked by the test of 9.18.

8.11 Operating characteristic

8.11.1 ARD classified according to 4.3.1, after tripping of the MPD, shall reclose it.

Compliance is checked by the test of 9.13.

8.11.2 ARD classified according to 4.3.2.1, after tripping of the MPD, shall perform the prospective earth-fault current assessment, and it shall reclose only if the prospective residual current does not exceed a given value.

Compliance is checked by the tests of 9.19.1.

8.11.3 ARD classified according to 4.3.2.2, after tripping of the MPD, shall perform the prospective line current assessment, and it shall reclose only if the line current does not exceed a given value.

Compliance is checked by the tests of 9.19.2.

8.11.4 ARD classified according both to 4.3.2.1 and 4.3.2.2, after tripping of the MPD, shall perform both the prospective earth-fault current and line current assessment and it shall reclose only if prospective residual current and/or line current do not exceed a given value.

Compliance is checked by the tests of 9.19.1 and 9.19.2.

8.11.5 ARD shall never perform a number of consecutive reclosing operation greater than those declared by the manufacturer, and for devices according to 4.7.1, the maximum number of operation shall not be greater than 3.

Compliance is checked by the test of 9.5.4.

8.11.6 ARD shall operate independently of the influence of distributed capacities in the installation.

Compliance is checked by the test of 9.19.3.1 (for ARDs classified according to 4.3.2.1) and 9.19.3.2 (for ARDs classified according to 4.3.2.2).

8.11.7 The admissible functions of the ARD are described in Table 3 depending on the supply voltage and on the MPD condition.

Table 3 – Behaviour of the ARD in enable condition

Supply voltage	MPD condition	ARD condition	Automatic reclosing admitted
Steady state ON or it returns after a break.	Tripped	Tripped	Yes
Steady state ON or it returns after a break.	Tripped	Blocked	No
Steady state ON or it returns after a break.	Manual opening ^a	Disabled ^b	No
^a According to 8.1.2.5. ^b According to classifications of 4.8.1 and 4.8.2.			

Compliance is checked by the tests of 9.5.2, 9.5.4, 9.19.1 and 9.19.2.

8.11.8 The standing current from the FE to the protective conductor shall not exceed 1,0 mA under normal supply conditions.

Compliance is checked by the test of 9.19.4.

8.12 Assessment means for ARD according to 4.3.2

8.12.1 General

ARDs according to 4.3.2 shall be so designed that the assessment shall only be performed under safe conditions for the user.

The assessment shall be performed using a circuit in which one of the following protective provisions is provided.

8.12.2 Assessment means operating by limitation of the test voltage

The limitation of voltage shall be provided by a transformer with a reinforced insulation between the primary and the secondary circuit.

The reinforced isolation shall be designed for a working voltage equal to 300 V for a transformer supplied by a rated voltage equal to 230 V and 600 V for ARD for a transformer supplied by a rated voltage equal to 400 V.

Compliance of the transformer is checked by requirements of 9.7.4.

The maximum voltage used to provide the assessment shall be lower than 24 V r.m.s.

Compliance is checked by the test of 9.20.1.

8.12.3 Assessment means operating by limitation of the test current

ARD shall be so designed that the steady-state current shall not exceed 1,0 mA a.c or 2,0 mA d.c. under normal operating in tripping conditions.

Compliance is checked by test of 9.20.2.

8.13 Safety in blocked condition

ARD shall be so designed that in blocked condition, the safety of the user is ensured.

Compliance is checked by test of 9.20.3.

8.14 Test device

The relevant subclause of the MPD standard applies:

- a) EN 61008-1:2004, 8.11, for ARD classified according to 4.2.2 (RCCBs);
- b) EN 61009-1:2004, 8.11, for ARD classified according to 4.2.3 (RCBOs).

Compliance is checked by the tests of 9.21.

8.15 Ageing

The relevant subclause of the MPD standard applies:

- a) EN 61008-1:2004, 8.16, for ARD classified according to 4.2.2 (RCCBs);
- b) EN 61009-1:2004, 8.16, for ARD classified according to 4.2.3 (RCBOs).

Compliance is checked by the tests of 9.22.

8.16 Electromagnetic compatibility (EMC)

ARD shall operate reliably in presence of electromagnetic disturbances and shall comply with relevant EMC requirements.

Compliance is checked according to 9.23.

9 Tests

9.1 General

The MPD to be fitted with ARD shall comply with its relevant product standard:

- a) EN 60898-1:2003 or EN 60898-2:2006, as applicable for ARD classified according to 4.2.1 (circuit-breakers);
- b) EN 61008-1:2004 for ARD classified according to 4.2.2 (RCCBs);
- c) EN 61009-1:2004 for ARD classified according to 4.2.3 (RCBOs).

In addition, the following tests shall be carried out to verify the whole assembly of the MPD with the ARD (ARD+MPD) mounted as for normal use.

These tests are made according Table E.1, where the tests in each sequence are carried out in the order indicated.

If the ARD is designed to be assembled to different MPDs, according to classification 4.2, it shall be tested according to Table D.2.

9.2 Test condition

The ARD assembled with its MPD is mounted individually according to manufacturer's instructions and in free air, at an ambient temperature as required by the standard for the MPD unless otherwise specified.

ARD designed for installation in individual enclosures are tested in the smallest of such enclosures specified by the manufacturer.

NOTE An individual enclosure is an enclosure designed to accept one device only.

Unless otherwise specified, the ARD is wired with the appropriate cable of cross-section specified in the relevant standard of the MPD and is fixed on a dull black painted plywood board of about 20 mm thickness, the method of fixing being in compliance with the requirements relating to the indications of the manufacturer concerning mounting.

Unless otherwise specified, the ARD is enabled.

Where tolerances are not specified, type tests are carried out at values not less severe than those specified in this European Standard. Unless otherwise specified, tests are carried out at the rated voltage and rated frequency $\pm 5\%$.

During the tests no maintenance or dismantling of the samples is allowed.

9.3 Measurement of the reclosing time after the tripping of the MPD

The ARD assembled with the MPD is supplied at rated voltage.

The MPD is caused to open automatically (e.g. by means of a tripping release). After the opening of the MPD, the ARD shall reclose. The test is carried out measuring the time interval for which the supply voltage is not present downstream.

9.4 Test of indelibility of marking

The test is made by rubbing the marking by hand for 15 s with a piece of cotton soaked with water and again for 15 s with a piece of cotton soaked with aliphatic solvent hexane with a content of aromatics of maximum 0,1 % by volume, a kauributanol value of 29, an initial boiling-point approximately 65 °C, a dry-point of approximately 69 °C and a density of approximately 0,68 g/cm³.

Marking made by impression, moulding, or engraving is not subjected to this test.

After this test, the marking shall be easily legible.

The marking shall also remain easily legible after all the tests of this European Standard.

It shall not be easily possible to remove labels and they shall show no curling.

9.5 Verification of the non influence of the ARD on the correct operation of the MPD

9.5.1 Verification of the operating characteristic of the MPD

For the ARD+MPD, the relevant subclause of the MPD standard applies:

- a) EN 60898-1:2003 or EN 60898-2:2006 as applicable, 8.1.2 ¹⁾, 9.10.1 and 9.10.2 (only at the upper limit of instantaneous tripping current), for ARD classified according to 4.2.1 (circuit-breakers);
- b) EN 61008-1:2004, 8.1.2 ¹⁾, 9.9.2.1, 9.9.2.2, 9.9.2.3 a), 9.15, for ARD classified according to 4.2.2 (RCCBs);
- c) EN 61009-1:2004, 8.1.2 ¹⁾, 9.9.1.2 a), 9.9.1.2 b), 9.9.1.2 c) 1), 9.9.2.1, 9.9.2.2 a) (only at the upper limit of instantaneous tripping current), 9.11, for ARD classified according to 4.2.3 (RCBOs).

Verification has to be carried out with enabled as well as with disabled ARD.

¹⁾ Only inspections and manual tests.

9.5.2 Verification of the impossibility of the activation of the ARD when the MPD has been manually opened

This test procedure only applies to devices according to 4.8.1.

The ARD is assembled as in normal use and supplied at rated voltage. The MPD is manually opened. If the enabling and disabling system is accessible and if it is independent from the main actuator, the test is carried out by applying a force equal to 20 N to the enabling /disabling system according to the manufacturer's instruction.

The force is applied for 1 min in the direction of normal actuation.

During the test the ARD shall not reclose the MPD.

The supply voltage is then switched off with the ARD in open position and then restored after 3 min: ARD shall not reclose the MPD.

The ARD is then reset according to the manufacturer's instruction and the test is repeated once.

9.5.3 Verification of the enabling/disabling system of the ARD

The ARD assembled with the MPD is installed as in normal use and supplied at rated voltage.

The test is carried out by means of 1 000 cycles of the enabling system with an operation frequency not less than 2 cycles per minute.

At the end of the test, the enabling system shall be able to work correctly.

The ARD being in the enabled position, the MPD is caused to open automatically (e.g. by means of a tripping release or by a residual current). It shall be reclosed automatically.

The ARD being in the disabled position, the MPD is caused to open automatically (e.g. by means of a tripping release or by a residual current). The ARD being supplied as in normal use. No automatic reclosing shall occur during at least 1 min or a time given by the manufacturer.

NOTE In order to minimize the total test duration, with manufacturer's agreement, the operating frequency may be increased.

9.5.4 Verification of the maximum number of consecutive reclosing

The MPD is caused to open automatically (e.g. by means of a tripping release or by a residual current). After the tripping and reclosing time (reclosing time may vary depending on number of reclosing operations), the ARD shall reclose and show the appropriate signal according to the manufacturer's instructions.

NOTE Reclosing time should be declared by manufacturer to testing laboratory as some products may have a reclosing time up to several hours.

The test is repeated for a maximum number of times as declared by the manufacturer.

Each test shall be separated from the previous reclosing by an interval less than 5 s.

At the end of the maximum number of consecutive reclosing operations as declared by the manufacturer, the ARD shall be in blocked condition and show the appropriate signal according to the manufacturer's instructions.

The supply voltage is switched off and then restored after 3 min: ARD shall not reclose and it shall show the appropriate signal according to the manufacturer's instructions.

The maximum number of consecutive reclosing operations shall be equal to 3 for devices according to 4.7.1 or equal to the declaration of the manufacturer for devices according to 4.7.2.

The ARD is then reset according to the manufacturer's instruction and the test is repeated once.

The test shall be repeated at 0,85 and 1,1 times the rated voltage.

9.6 Tests of creepage distances and clearances for electronic circuits (abnormal conditions)

9.6.1 These tests replace the verifications of creepage distances and clearances of electronic circuits connected between live parts (phases and neutral) and/or between live parts and the earth circuit.

ARD shall not create fire and/or shock hazards under abnormal conditions likely to occur in service.

The conditions under which a component is used within an ARD unit shall be in accordance with the operating characteristics marked on the component and/or given in the data provided by the manufacturer.

9.6.2 When the ARDs are exposed to abnormal conditions, no part shall reach temperatures likely to cause danger of fire to the surroundings of the ARD, and no live parts shall become accessible.

Compliance is checked by subjecting the ARD to a heating test under fault conditions as described in 9.6.3.

9.6.3 Unless otherwise specified, the tests are made on ARD, connected and loaded as in normal use.

Examination of the ARD and its circuit diagram will show the fault conditions that shall be applied.

Generally one separate sample is submitted for each fault condition to be tested.

Each of the following fault conditions a) to e) shall be applied in turn, one test only being carried out for

- a) short-circuit across clearances and creepage distances smaller than those given by curve A of Figure 1, with the following exception.

In the case of a printed-board complying with the pull-off and peel strength requirements specified in EN 61189-2, the creepage distances and clearances between conductors, one of which may be connected to one pole of the supply mains, the values resulting from Figure 1 are replaced by the values calculated from the formula

$$\log d = 0,78 \log (V/300) \text{ with a minimum of } 0,2 \text{ mm}$$

where

d is the distance in millimetres;

V is the peak value of the voltage in volts.

These distances can be determined by reference to Figure 2.

The above-reduced values apply to the conductors themselves, but not to mounted components or associated soldered connections. Covering lacquer or the like on printed boards are ignored when calculating the distances.

Clearances and creepage distances complying with the requirements of Table 2, and printed boards with type B coating complying with EN 60664-3 are excluded from this test;

- b) short-circuit across insulation coating consisting, for example, of lacquer or enamel;
c) short-circuit or interruption of semiconductor devices;

NOTE For integrated circuits and other semiconductor devices with more than two terminals, the number of tests theoretically required makes it impracticable to apply the open circuiting and/or shorting of all combinations of terminals. In this case, it is permissible first to analyze in detail, by a desk study, all the possible mechanical, thermal and electrical faults which may develop in the ARD due to the malfunction of the electronic device or other circuit components. Only the combinations corresponding to faults that, on the basis of this analysis, are considered to be likely to cause the non-compliance of the ARD with the requirements of the two last paragraphs of this subclause have to be investigated by this method.

- d) short circuit of electrolytic capacitors;
e) short circuit or disconnection of capacitors, resistors and inductors or which do not comply with the requirements of 9.7.2, 9.7.3 and 9.7.4.

The temperatures resulting from the fault conditions are measured for the parts mentioned in Table 4 after steady-state has been reached, or after 4 h (whichever is the shorter time) under each of the fault conditions a) to e).

These temperatures shall not exceed the values given in Table 4.

Table 4 – Maximum permissible temperatures under abnormal conditions

Parts of the ARD			Permissible temperature rise K
External parts	Metal parts	Knobs, handles, sensing surfaces, etc.	75
		Enclosure ^a	75
	Non-metal parts	Knobs, handles, sensing surfaces, etc. ^b	75
		Enclosure ^{a,b}	75
Inside of enclosures of insulating material			^c
Windings ^d	Class A		115
	Class E		130
	Class B		140
	Class F		155
	Class H		175
	Class 200		195
	Class 220		215
	Class 250		245
Core laminations			As for the relevant windings
Supply cable and wiring	Insulated with ordinary polyvinyl chloride ^e	Not under mechanical stress	110
		Under mechanical stress	110
	Insulated with natural rubber		110
Other insulations ^{d,f} except thermoplastic	Non-impregnated paper		80
	Non-impregnated cardboard		90
	Impregnated cotton, silk, paper and textile, urea resins		100
	Laminates bonded with phenol-formaldehyde resins, phenol-formaldehyde mouldings with cellulose fillers		120
	Phenol-formaldehyde mouldings with mineral fillers		140
	Laminates bonded with epoxy resins		160
	Natural rubber		110
Thermoplastic materials ^g			^h
Terminals and parts which may come into contact with cable insulation when installed			110
The values of the temperature rises are based on an ambient temperature of 25 °C, but the measurements are made under normal conditions.			
<p>^a For areas not exceeding 5 cm² and which are not likely to be touched in normal use, temperature rises up to 75 K are allowed under normal operating conditions.</p> <p>^b If these temperature rises are higher than those allowed by the class of the relevant insulating material, the nature of the material is the governing factor.</p> <p>^c The permissible temperature rises for the inside of enclosures of insulating material are those indicated for the relevant materials.</p> <p>^d For the purpose of this European Standard, the permissible temperature rises are based on the recommendations in EN 60085. The materials quoted above are shown only as examples. If materials other than those listed in EN 60085 are used, the maximum temperatures must not exceed those which have been proved to be satisfactory.</p> <p>^e The possibility of raising the values for wires and cables insulated with heat-resistant polyvinyl chloride is under consideration.</p> <p>^f The table does not apply to components which comply with relevant EN standards.</p> <p>^g Natural and synthetic rubbers are not considered as being thermoplastic materials.</p> <p>^h Due to their wide variety, it is not possible to specify permissible temperature rises for thermoplastic materials. While the matter is under consideration, the following method shall be used.</p> <p>1) The softening temperature of the material is determined on a separate specimen, under the conditions specified in EN ISO 306, modified as follows:</p> <ul style="list-style-type: none"> – the depth of penetration is 0,1 mm; – the total thrust of 10 N is applied before the dial gauge is set to zero or its initial reading noted. <p>2) The temperature limits to be considered for determining the temperature rises are:</p> <ul style="list-style-type: none"> – under normal operating conditions, a temperature 10 °C lower than the softening temperature as obtained under 1); – under fault conditions, the softening temperature itself. 			

9.7 Requirements for capacitors and specific resistors and inductors used in electronic circuits

9.7.1 General

These requirements apply for capacitors (see 9.7.2), specific resistors and inductors (see 9.7.3) and inductors and windings (see 9.7.4) used in electronic circuits connected between live parts (phases and neutral) and/or between live parts and the earth circuit when the contacts are in the closed position.

9.7.2 Capacitors

Capacitors,

- the short-circuiting or disconnection of which would cause an infringement of the requirements under fault conditions with regard to shock or fire hazard,
- the short-circuiting of which would cause a current of 0,5 A or more through the terminals of the capacitor,
- for suppression of electromagnetic interference,

shall comply with EN 60384-14 series.

NOTE Capacitors passing the damp heat steady-state test specified in EN 60384-14:2005, 4.12, with a duration of not less than 21 days are considered acceptable.

These capacitors shall be marked with their rated voltage in volts (V), their rated capacitance in microfarads (μF) and their reference temperature in degrees Celsius ($^{\circ}\text{C}$).

9.7.3 Resistors

Resistors, the short-circuiting or interruption of which would cause an infringement of the requirements with regard to the protection against fire and electric shock in case of a defect, shall have an adequately constant value under the overload conditions prevailing in the electronic switch.

These resistors shall comply with the requirements of EN 60065:2002, 14.1.

Tests already carried out on resistors and inductors complying with EN 60065 are not required to be repeated.

9.7.4 Inductors and windings

Inductors and windings shall comply with the requirements of EN 61558-1 and the relevant parts of EN 61558-2 series as applicable.

9.8 Test of reliability of screws, current-carrying parts and connections

For the ARD+MPD, the relevant subclause of the MPD standard applies:

- a) EN 60898-1:2003 or EN 60898-2:2006 as applicable, 9.4, for ARD classified according to 4.2.1 (circuit-breakers);
- b) EN 61008-1:2004, 9.4, for ARD classified according to 4.2.2 (RCCBs);
- c) EN 61009-1:2004, 9.4, for ARD classified according to 4.2.3 (RCBOs).

The test is repeated on terminals for screws, current carrying parts and connection of the MPD only if their are used to connect them to ARD and only if the cross-section area of these conductors is different as stated in EN 60898-1:2003 or EN 60898-2:2006 as applicable, Table 5, or in EN 61008-1:2004, Table 4, or in EN 61009-1:2004, Table 6.

9.9 Test of reliability of terminals for external conductors

For the ARD+MPD, the relevant subclause of the MPD standard applies:

- a) EN 60898-1:2003 or EN 60898-2:2006 as applicable, 9.5, for ARD classified according to 4.2.1 (circuit-breakers);
- b) EN 61008-1:2004, 9.5, for ARD classified according to 4.2.2 (RCCBs);
- c) EN 61009-1:2004, 9.5, for ARD classified according to 4.2.3 (RCBOs).

If types or sizes of terminals are used, which are not considered in the MPD standard a), b) or c), generic standards for terminals shall apply (for example piercing terminals according to EN 60998-2-3).

The test is repeated on terminals for external conductors of the MPD only if their are used to connect the MPD to the ARD and only if the cross section area of these conductors is different as stated in EN 60898-1:2003 or EN 60898-2:2006 as applicable, Table 5 or in EN 61008-1:2004, Table 4 or in EN 61009-1:2004, Table 6.

9.10 Verification of protection against electric shock

For the ARD+MPD, the relevant subclause of the MPD standard applies:

- a) EN 60898-1:2003 or EN 60898-2:2006 as applicable, 9.6, for ARD classified according to 4.2.1 (circuit-breakers);
- b) EN 61008-1:2004, 9.6, for ARD classified according to 4.2.2 (RCCBs);
- c) EN 61009-1:2004, 9.6, for ARD classified according to 4.2.3 (RCBOs).

9.11 Test of dielectric properties and isolating capability

The following subclauses of the standard for the MPD apply:

- a) EN 60898-1:2003 or EN 60898-2:2006 as applicable, 9.7, for ARD classified according to 4.2.1 (circuit-breakers);
- b) EN 61008-1:2004, 9.7, for ARD classified according to 4.2.2 (RCCBs);
- c) EN 61009-1:2004, 9.7, for ARD classified according to 4.2.3 (RCBOs),

with the following modifications.

Where the standard requires that the protective device is in open position, the test is carried out with the MPD+ARD in manually opened condition according to the manufacturer's instructions. All the other tests are carried out with the ARD in all possible conditions.

Where the standard requires that the protective device is in open position, the test is carried out with the ARD in isolation condition (e.g. the symbol O is visible).

If the ARD is provided with a terminal intended for the connection of protective conductors, this is connected to the frame.

If the ARD is provided with a terminal intended for the connection of functional earthing conductors, this is not connected to the frame.

9.12 Temperature rise

For the ARD+MPD, the following subclauses of the MPD standard apply, a current equal to its rated current is passed simultaneously through all the poles of the MPD and the ARD supplied as for normal use with rated voltage:

- a) EN 60898-1:2003 or EN 60898-2:2006 as applicable, 9.8, for ARD classified according to 4.2.1 (circuit-breakers);
- b) EN 61008-1:2004, 9.8, for ARD classified according to 4.2.2 (RCCBs);
- c) EN 61009-1:2004, 9.8, for ARD classified according to 4.2.3 (RCBOs).

The test current in the MPDs may be generated at reduced voltage but the ARD shall be supplied at their rated voltage. For this reason, tests shall be made on samples specially prepared by the manufacturer or according to his instructions.

9.13 Verification of the mechanical and electrical endurance – Verification of the reclosing system of the ARD

9.13.1 General test conditions

The ARD assembled with the MPD is installed as in normal use and supplied at rated voltage.

The MPD is caused to open automatically (e.g. by means of a tripping release), after tripping the ARD shall reclose.

The operating frequency shall be 12 operating cycles per hour or at highest frequency compatible with reclosing time and with the reset time to avoid the blocked condition.

NOTE In order to minimize the total test duration, with manufacturer's agreement, the operating frequency may be increased but in any case without exceeding the operating frequency of 4 cycles per minute.

9.13.2 Test procedure

The ARD is subjected to 500 operating cycles, each operation cycle consisting of a tripping operation of the MPD followed by a closing operation.

9.13.3 Condition of the ARD after the test

After the tests, the ARD shall not show any damage, which could impair further use.

After the test, compliance with 9.5.4 is checked. Compliance with 9.19.1 and/or 9.19.2 as applicable is also checked for devices classified according to 4.3.2.

9.14 Short-circuit test

9.14.1 General conditions for short-circuit test

The ARD+MPD shall be in a new and clean condition, assembled to a MPD in a new and clean condition.

9.14.2 Test circuit and test quantities

For the ARD+MPD, the relevant subclause of the MPD standard applies:

- a) EN 60898-1:2003 or EN 60898-2:2006 as applicable, 9.12.2 and 9.12.4, for ARD classified according to 4.2.1 (circuit-breakers);
- b) EN 61008-1:2004, 9.11.2.1, for ARD classified according to 4.2.2 (RCCBs);
- c) EN 61009-1:2004, 9.12.2 and 9.12.3, for ARD classified according to 4.2.3 (RCBOs).

9.14.3 Test procedure

For the ARD+MPD, the relevant subclause of the MPD standard applies:

- a) EN 60898-1:2003 or EN 60898-2:2006 as applicable, 9.12.11.4.2, for ARD classified according to 4.2.1 (circuit-breakers);
- b) EN 61008-1:2004, 9.11.2.4 a), for ARD classified according to 4.2.2 (RCCBs);
- c) EN 61008-1:2004, 9.11.2.3 b), for ARD classified according to 4.2.2 (RCCBs);
- d) EN 61009-1:2004, 9.12.11.4 b), for ARD classified according to 4.2.3 (RCBOs);
- e) EN 61009-1:2004, 9.12.11.4 d), for ARD classified according to 4.2.3 (RCBOs).

In case of ARD classified according to 4.3.1 and 4.7.2, the CO operation shall be performed for a number of times equal to the maximum number of reclosing operations but the time interval t between two successive operations shall not be less than 3 min or the reclosing time declared by manufacturer, whichever is the longer.

In case of ARD classified according to 4.3.2, the ARD shall be disabled and the MPD shall be closed manually.

After the tests, the ARD shall be verified according to 9.14.4.

9.14.4 Condition of the ARD after the test

After the test, the ARD+MPD shall perform the following test of the relevant subclause of the MPD standard:

- a) EN 60898-1:2003 or EN 60898-2:2006 as applicable, 9.12.12.2, for ARD classified according to 4.2.1 (circuit-breakers);
- b) EN 61008-1:2004, 9.11.2.1 i), for ARD classified according to 4.2.2 (RCCBs);
- c) EN 61009-1:2004, 9.12.12.2 and 9.12.12.Z1, for ARD classified according to 4.2.3 (RCBOs).

After the test, compliance with 9.5.4 is checked. Compliance with 9.19.1 and/or 9.19.2 as applicable is also checked for devices classified according to 4.3.2.

9.15 Resistance to mechanical shock and impact

For the ARD+MPD, the following subclauses of the standard for the MPD apply:

- a) EN 60898-1:2003 or EN 60898-2:2006 as applicable, 9.13, for ARD classified according to 4.2.1 (circuit-breakers);
- b) EN 61008-1:2004, 9.12, for ARD classified according to 4.2.2 (RCCBs);
- c) EN 61009-1:2004, 9.13, for ARD classified according to 4.2.3 (RCBOs).

9.16 Test of resistance to heat

For the ARD+MPD, the following subclauses of the standard for the MPD apply:

- a) EN 60898-1:2003 or EN 60898-2:2006, 9.14, for ARD classified according to 4.2.1 (circuit-breakers);
- b) EN 61008-1:2004, 9.13, for ARD classified according to 4.2.2 (RCCBs);
- c) EN 61009-1:2004, 9.14, for ARD classified according to 4.2.3 (RCBOs).

In case of ARD according to 4.1.2, the test is carried out only on ARD part.

9.17 Resistance to abnormal heat and to fire

For the ARD+MPD, the following subclauses of the standard for the MPD apply:

- a) EN 60898-1:2003 or EN 60898-2:2006 as applicable, 9.15, for ARD classified according to 4.2.1 (circuit-breakers);
- b) EN 61008-1:2004, 9.14, for ARD classified according to 4.2.2 (RCCBs);
- c) EN 61009-1:2004, 9.15, for ARD classified according to 4.2.3 (RCBOs).

In case of ARD according to 4.1.2, the test is carried out only on ARD part.

9.18 Verification of the correct operation at low ambient air temperatures for RCCBs for use at temperatures between -25 °C and +40 °C

For the ARD+MPD, the relevant subclause of the MPD standard applies:

- a) EN 61008-1:2004, 9.Z1, for ARD classified according to 4.2.2 (RCCBs);
- b) EN 61008-1:2004, 9.Z1, for ARD classified according to 4.2.3 (RCBOs).

9.19 Verification of the operating characteristics

NOTA This verification is not performed for ARD according to 4.3.1.

9.19.1 Verification of the reclosing subordinated to the measurements of the resistance to earth

- a) The test circuit shall correspond to Figure 3 or Figure 4 as applicable. The resistor R1 shall be adjusted at any convenient value which leads ARD+MPD to trip. The resistor R2 shall be adjusted to the value equal to R_{d0} . The MPD is made to trip by closing the test switch S1, immediately after the tripping of the ARD, the switch S1 shall be opened. The ARD shall reclose.

The test is repeated three times on a pole taken at random which shall not be the switched neutral.

Each test shall be separated from the previous reclosing by an interval of at least 30 s.

- b) The test circuit shall correspond to Figure 3 or Figure 4 as applicable. The resistor R1 shall be adjusted at any convenient value which leads ARD+MPD to trip. The resistor R2 shall be adjusted to the value equal to R_d . The MPD is made to trip by closing the test switch S1, immediately after the tripping of the ARD+MPD, the switch S1 shall be opened. The ARD shall not reclose and ARD shall show the appropriate signal according to the manufacturer's instructions.

After this test, the resistor R2 is removed and the ARD classified according to 4.3.2.1 a) shall not reclose; the ARD classified according to 4.3.2.1 b) shall reclose according to the manufacturer's instructions.

The test is repeated three times on a pole taken at random which shall not be the switch neutral.

Each test shall be separated from the previous reclosing by the reset of the ARD.

9.19.2 Verification of the reclosing subordinated to the measurements of the resistance between live parts

- a) The test circuit shall correspond to Figure 5. The resistor R1 shall be adjusted to the value equal to R_{cc0} . The MPD is caused to open automatically (e.g. by means of a tripping release), immediately after the tripping of the ARD+MPD, the switch S1 shall be close. The ARD shall reclose.

The test is repeated three times on one possible combination of live parts taken at random.

Each test shall be separated from the previous one by an interval of at least 3 min.

- b) The test circuit shall correspond to Figure 5. The resistor R1 shall be adjusted to the value equal to R_{cc} . The MPD is caused to open automatically (e.g. by means of a tripping release), immediately after the

tripping of the ARD+MPD, the switch S1 shall be close. The ARD shall not reclose and ARD shall show the appropriate signal according to the manufacturer's instructions.

After this test the resistor R2 is removed and the ARD classified according to 4.3.2.2 a) shall not reclose; the ARD classified according to 4.3.2.2 b) shall reclose according to the manufacturer's instructions.

The test is repeated three times on one possible combination of live parts taken at random.

Each test shall be separated from the previous reclosing by the reset of the ARD.

9.19.3 Verification of the influence of the distributed capacities in the installation on the operating characteristic

9.19.3.1 Verification of the reclosing subordinated to the measurements of the resistance between live parts to earth

The test conditions specified in 9.19.1 a) and 9.19.1 b) apply inserting a capacitor of 100 nF in parallel to the resistor R2.

The test shall be carried out at 0,85 and 1,1 times the rated voltage at the following temperatures: $(-5 \pm 2)^\circ\text{C}$, $(20 \pm 2)^\circ\text{C}$, $(40 \pm 2)^\circ\text{C}$ after the steady state is reached.

ARD classified in according with 4.5.2 shall also perform the test with an ambient temperature of -25°C .

9.19.3.2 Verification of the reclosing subordinated to the measurements of the resistance between live parts

The test conditions specified in 9.19.2 a) and 9.19.2 b) apply inserting a capacitor of 100 nF in parallel to the resistor R1.

The test shall be carried out at 0,85 and 1,1 times the rated voltage at the following temperatures: $(-5 \pm 2)^\circ\text{C}$, $(20 \pm 2)^\circ\text{C}$, $(40 \pm 2)^\circ\text{C}$ after the steady state is reached.

RCDs classified in according with 4.5.2 shall also perform the test with an ambient temperature of -25°C .

9.19.4 Verification of the maximum current in FE under normal condition

The ARD is installed as in normal use and supplied at a voltage 1,1 times its rated voltage.

The test circuit shall be in accordance with the Figure 6. The resistor R1 shall be adjusted at a value of $1\ \Omega$.

The test current in the resistor R1 is measured by the use of an appropriate mean (e.g. oscilloscope, ammeter).

The test current shall not exceed $1,0\ \text{mA r.m.s.}$

The device is then made to trip, and the measurement is performed again.

9.20 Verification of the safety during the assessment

9.20.1 Verification of the limitation of the voltage

The ARD and the MPD are installed as in normal use, supplied at 1,1 rated voltage and without any load.

The MPD is made to trip and the voltage on the load terminals of the ARD+MPS is measured by an appropriate means (example: oscilloscope, voltmeter, etc.) before the ARD recloses.

The voltage shall not exceed $24\ \text{V r.m.s.}$

In case of ARD provided with an FE, the following test shall be carried out.

9.20.2 Verification of the limitation of the test current

The ARD is installed as in normal use and supplied at a voltage 1,1 times its rated voltage.

The test circuit shall correspond to Figure 3 or Figure 4 as applicable. The resistor R1 shall be adjusted at any convenient value which leads ARD to trip.

The R2 shall be replaced by a connection of negligible value.

The test current in the resistor R2 is measured by the use of an appropriate mean (e.g. oscilloscope, ammeter).

The test current shall not exceed 1,0 mA r.m.s or 2,0 mA d.c.

In case of ARD provided with an FE, the following test shall be carried out.

The ARD and the MPD are installed as in normal use, supplied at 1,1 rated voltage and without any load.

The MPD is made to trip. The test current in the FE is measured by the use of an appropriate mean (e.g. oscilloscope, ampermetre).

The test current shall not exceed 1,0 mA r.m.s or 2,0 mA d.c.

9.20.3 Verification of the safety in blocked condition

The ARD is installed as in normal use and supplied at a voltage 1,1 times its rated voltage.

The MPD shall be made to trip for the maximum number of consecutive reclosing operations as declared by the manufacturer in order to get the ARD in blocked condition.

For ARD classified as 4.4.1, the verification is made by repeating the test of 9.20.1.

For ARD classified as 4.4.2, the verification is made by repeating the test of 9.20.2.

For ARD classified as 4.3.1, the relevant subclause of the MPD standard applies, without humidity treatment:

- a) EN 60898-1:2003 and EN 60898-2:2006, 9.7.3, for ARD classified according to 4.2.1 (circuit-breakers);
- b) EN 61008-1:2004, 9.7.3, for ARD classified according to 4.2.2 (RCCBs);
- c) EN 61009-1:2004, 9.7.3, for ARD classified according to 4.2.3 (RCBOs).

9.21 Verification of the operation of the test device at the limits of rated voltage

For the ARD+MPD, the relevant subclause of the MPD standard applies:

- a) EN 61008-1:2004, 9.16, for ARD classified according to 4.2.2 (RCCBs);
- b) EN 61009-1:2004, 9.16, for ARD classified according to 4.2.3 (RCBOs).

It may be necessary to increase the interval time between two consecutive operations up to the reset time.

9.22 Verification of ageing

The ARD+MPD is placed for a period of 168 h in an ambient temperature of $(40 \pm 2) ^\circ\text{C}$ and loaded with the rated current. The voltage on the electronic parts shall be 1,1 times the rated voltage.

After this test, the ARD+MPD in the cabinet is allowed to cool down to approximately room temperature without current passing. The electronic parts shall show no damage.

After the test, compliance with 9.5.4 is checked. Compliance with 9.19.1 and/or 9.19.2 as applicable is also checked for devices classified according to 4.3.2.

9.23 Electromagnetic compatibility

9.23.1 General

Standard ARD electromagnetic environmental conditions are those conditions which occur in installations connected to low voltage public networks or similar installations.

These tests are based on EN 61543 and carried out with the MPD in closed position and the ARD enabled.

NOTE 1 EN 61000-3-2 is not required as the power dissipation of the POP is below the power limit.

NOTE 2 EN 61000-3-3 is not required as POP are unlikely to produce significant voltage fluctuations or flicker.

9.23.2 Low frequency electromagnetic phenomena

The data for the low frequency immunity to be applied are set out in Table 5.

Table 5 – Low frequency immunity test conditions

Reference	Electromagnetic phenomena	Reference of basic standard for test description	Test level and test specification	Subclauses including the performance criteria
T 5.1	Harmonics, interharmonics	No requirements		
T 5.2	Signalling voltages	No requirements		
T 5.3	Voltage amplitude variations			
	Voltage fluctuations	9.5.4 and, for devices classified 4.3.2, with 9.19.3.1 and/or 9.19.3.2 as applicable	From 0,85 U to 1,1 U	9.23.6
	Voltage dips	9.17 of EN 61008-1 and EN 61009-1		
	Voltage interruptions	9.17 of EN 61008-1 and EN 61009-1		
T 5.4	Voltage unbalance	Refer to T 6.3		
T 5.5	Power frequency variations	^a		
T 5.6	Magnetic field	9.14 applies		
^a Immunity from power frequency variations is ensured by the fact that all performances of the device are tested at frequencies which may be subjected to variations in the range of $\pm 5\%$ of the rated frequency: see 9.2.				

9.23.3 High frequency immunity

The data for the high frequency immunity to be applied are set out in Table 6.

Table 6 – High-frequency immunity test conditions

Reference	Electromagnetic phenomena	Reference of basic standard for test description	Test level and test specification	Subclauses including the performance criteria
T 6.1	Conducted sine-wave form voltages or currents	EN 61000-4-6 ^a	0,15 MHz to 80 MHz Z = 150 Ω 3 V	9.23.6
T 6.2	Fast transients (bursts) Common mode	EN 61000-4-4 ^b	Level 2: 2 kV (peak) Tr/Th: 5 ns/50 ns Repetition frequency: 2,5 kHz	9.23.6 ^c
T 6.3	Surges	EN 61000-4-5	Tr/Th: 1,2 μs/50 μs 4 kV common mode 2 kV differential mode	9.23.6
T 6.4	Radiated electromagnetic field	EN 61000-4-3	80 MHz – 1 000 MHz 10 V/m	9.23.6
T 6.5	Conducted common mode disturbances in the frequency range lower than 150 kHz	Values derived from EN 61000-4-16	Level 3 ^d	9.23.6

^a With the agreement of the manufacturer, the conducted test T 7.1 can be extended from 80 MHz to 230 MHz. In this case, the test T 7.4 is to start from 230 MHz instead of 80 MHz.

^b In addition, the sample shall be mounted as in normal use on a flat insulating support at a distance of 10 cm from the earth plane.

^c The test is carried out in single phase on one pole of each sample taken at random.

^d Current levels are given in EN 61543:1995, Table 5a. They are derived from EN 61000-4-16, taking into account a common mode impedance of 150 Ω. Conventional test currents are applied according to EN 61543:1995, Figure 1. The test circuit is given in EN 61543:1995, Figure 1. A simplification of this test is given in EN 61543.

9.23.4 Electrostatic discharges

The data for the electrostatic discharge tests to be applied are set out in Table 7.

Table 7 – Test conditions for electrostatic discharges

Reference	Electromagnetic phenomena	Reference of basic standard for test description	Test level and test specification	Subclauses including the performance criteria
T 7.1	Electrostatic discharges	EN 61000-4-2	Level 3 8 kV air 6 kV contact	9.23.6 ^a

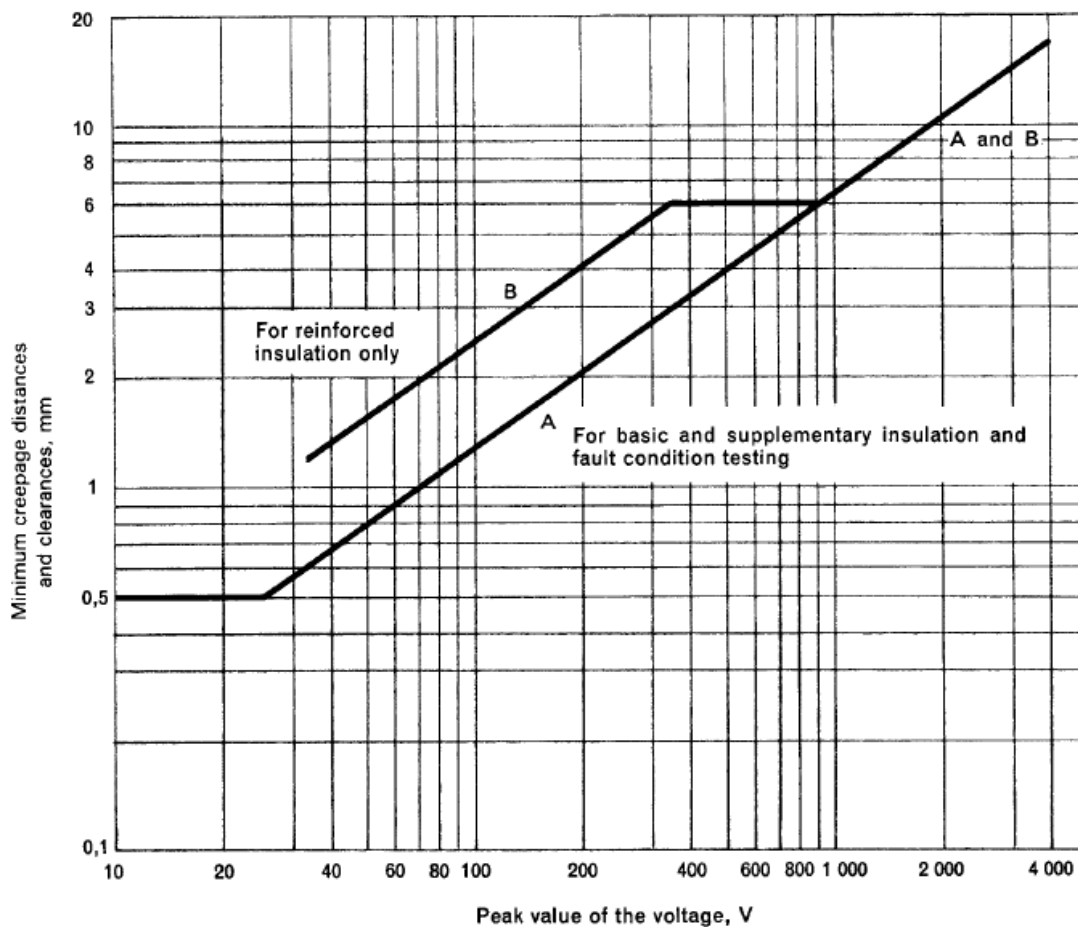
^a Three new samples are submitted to the test. All three samples shall pass the test.
The point to which discharges shall be applied is selected by an exploration of the accessible surfaces of the ARD, when installed as for normal use.
During exploration, the selection is made with 20 discharges per second.
The selected point is tested with 10 positive and 10 negative polarity discharges with a time interval of minimum 1 s between subsequent discharges.

9.23.5 Electromagnetic emission of ARDs

Emission tests are required only for ARDs containing a continuously operating oscillator. They shall be carried out according to EN 55014-1.

9.23.6 Performance criteria

After the test, compliance with 9.5.4 is checked. Compliance with 9.19.1 and/or 9.19.2 as applicable is also checked for devices classified according to 4.3.2.



For parts conductively connected to the supply mains with voltages in the range of 220 V – 250 V (r.m.s.), the dimensions are equal to those related to 354 V peak.

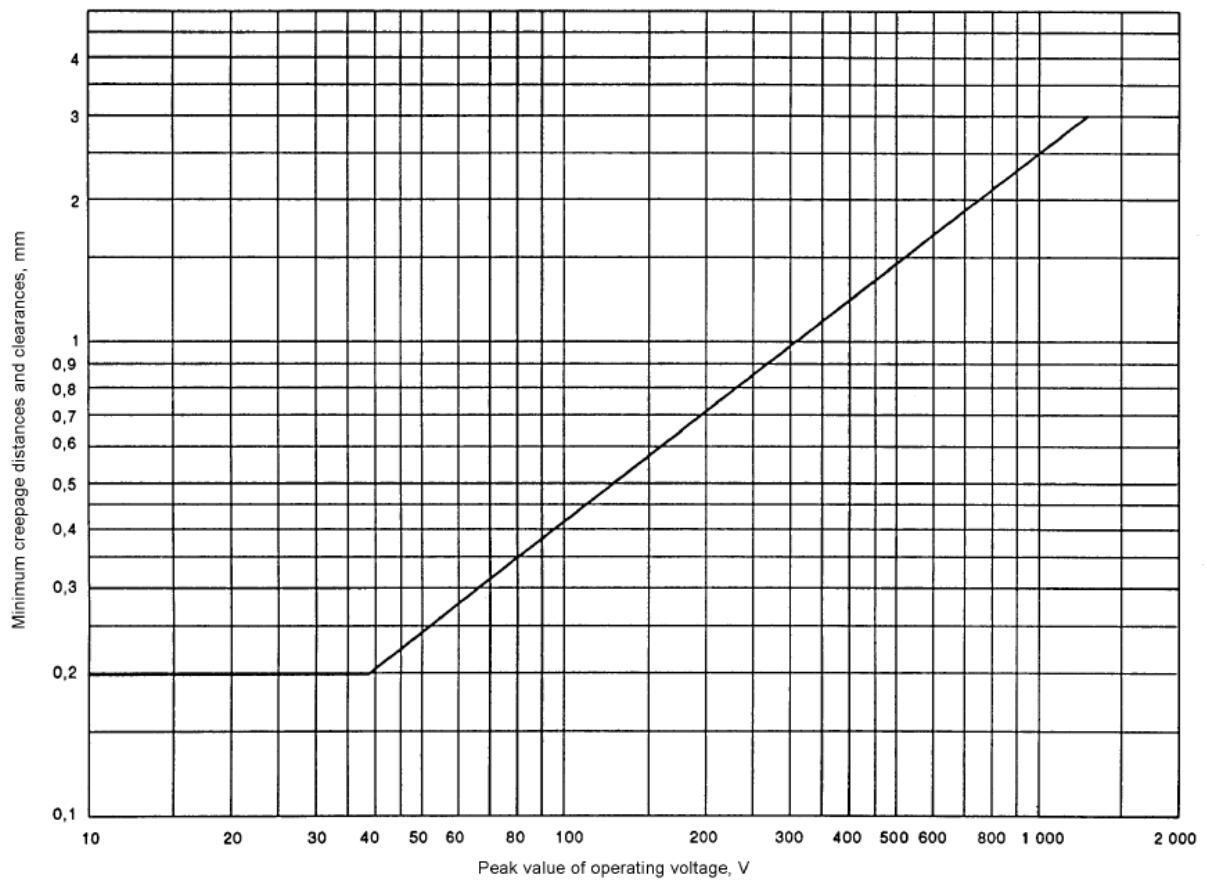
A voltage across the basic insulation is determined by short-circuiting the supplementary insulation and vice versa.

The graphs of EN 60065:2002, Figure 9, are defined by the following:

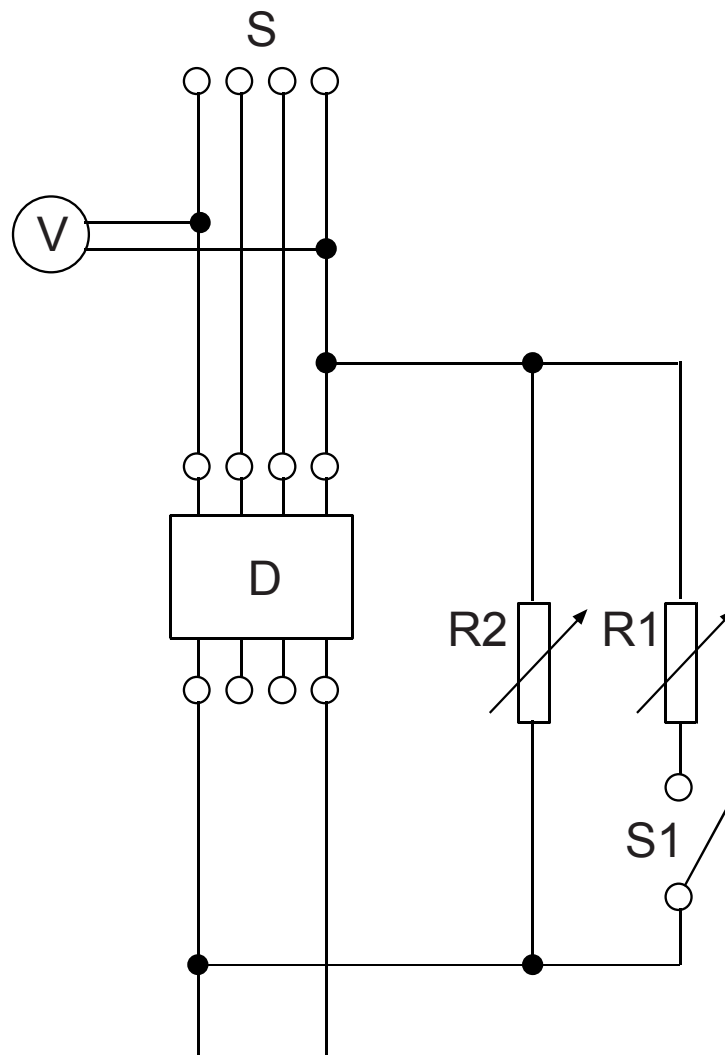
- Curve A: 34 V corresponds to 0,6 mm
354 V corresponds to 3,0 mm
- Curve B: 34 V corresponds to 1,2 mm
354 V corresponds to 6,0 mm

Under certain conditions, these distances may be reduced as given in 9.6.3 a).

Figure 1 – Minimum creepage distances and clearances measured in millimetres

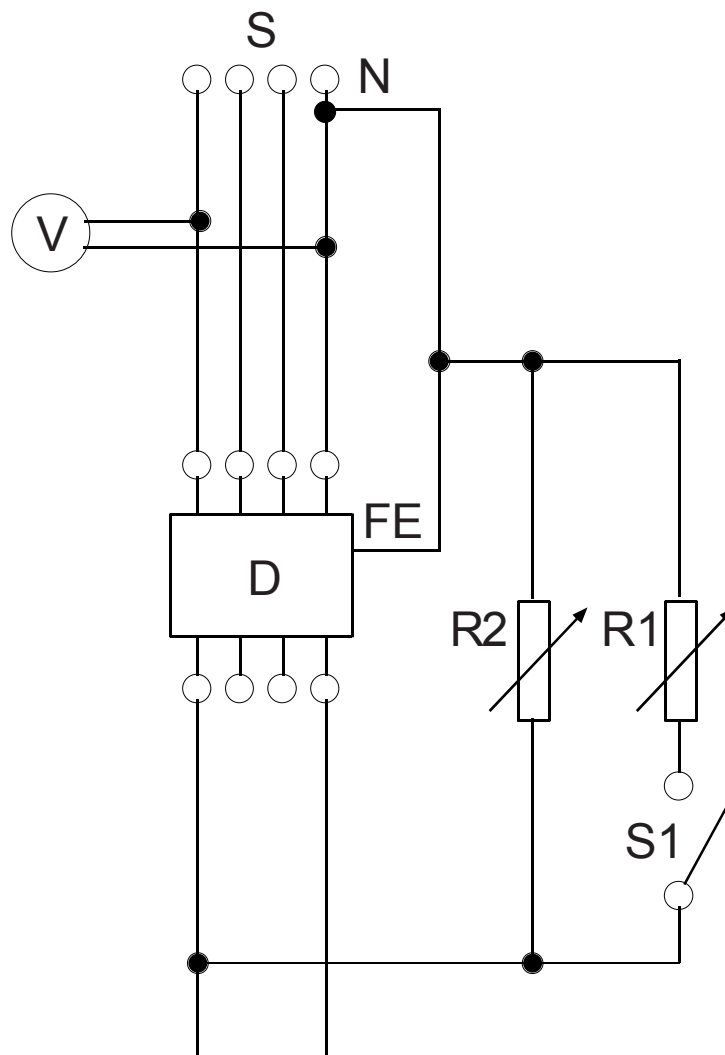


**Figure 2 – Minimum creepage distances and clearances
as a function of peak value of operating voltage**

**Key**

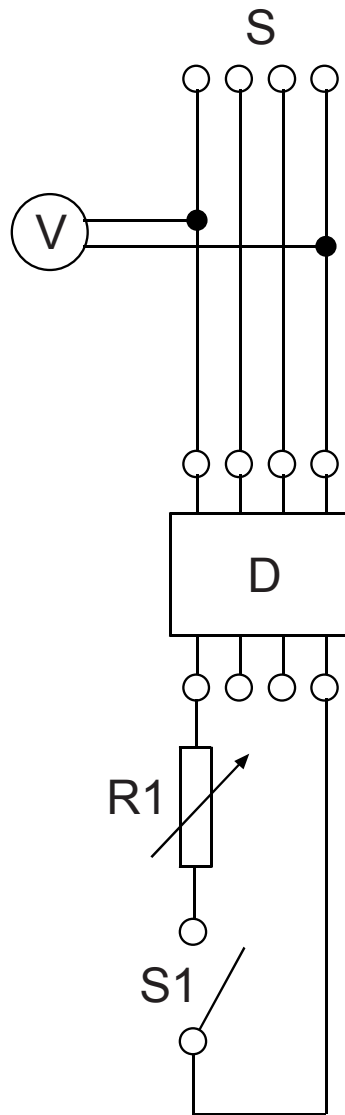
- D ARD or ARD+MPD, as applicable, under the test
- R1 variable resistor
- R2 variable resistor
- S supply
- S1 switch
- V voltmeter

Figure 3 – Verification of the reclosing subordinated to the measurements of the resistance to earth for ARD without functional earthing (9.19.1 a) – 9.19.1 b) – 9.20.2)

**Key**

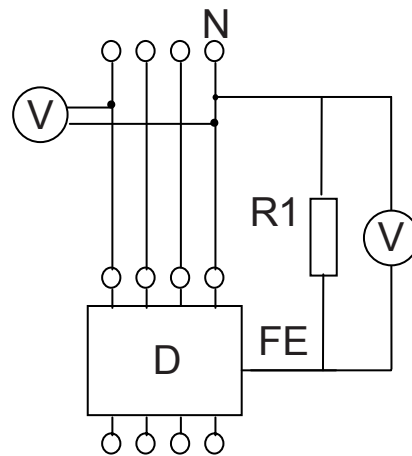
- D ARD or ARD+MPD, as applicable, under the test
- FE functional earth connection
- N neutral connection
- R1 variable resistor
- R2 variable resistor
- S supply
- S1 switch
- V voltmeter

Figure 4 – Verification of the reclosing subordinated to the measurements of the resistance to earth for ARD with functional earthing (9.19.1 a) – 9.19. 1 b) – 9.20.2)

**Key**

- D ARD under the test
- R1 variable resistor
- S supply
- S1 switch
- V voltmeter

Figure 5 – Verification of the reclosing subordinated to the measurements of the resistance between live parts (9.19.2 a) – 9.19.2 b))

**Key**

- D ARD or ARD+MPD, as applicable, under the test
- FE functional earth connection
- N neutral connection
- R1 variable resistor
- V voltmeter

Figure 6 – Test circuit for the verification of the maximum current in FE under normal condition

Annex A (informative)

Classification of ARDs according to 4.3.1

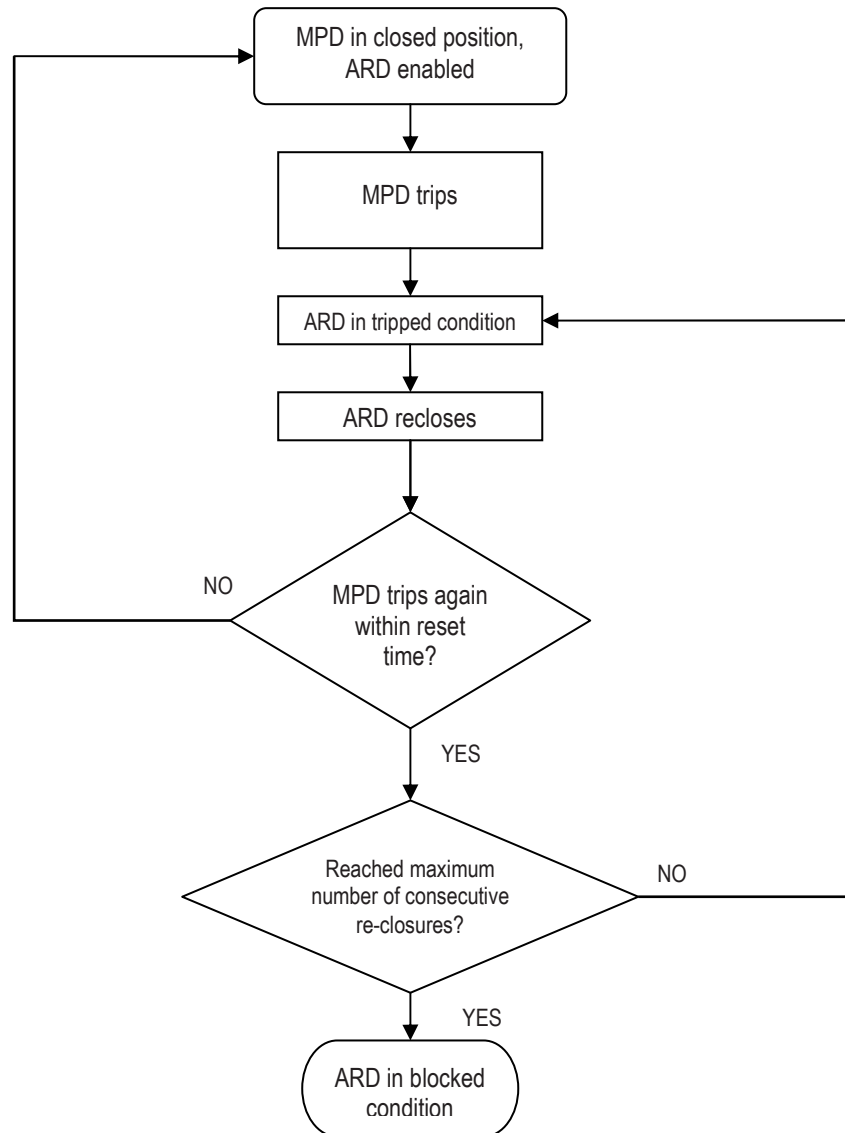
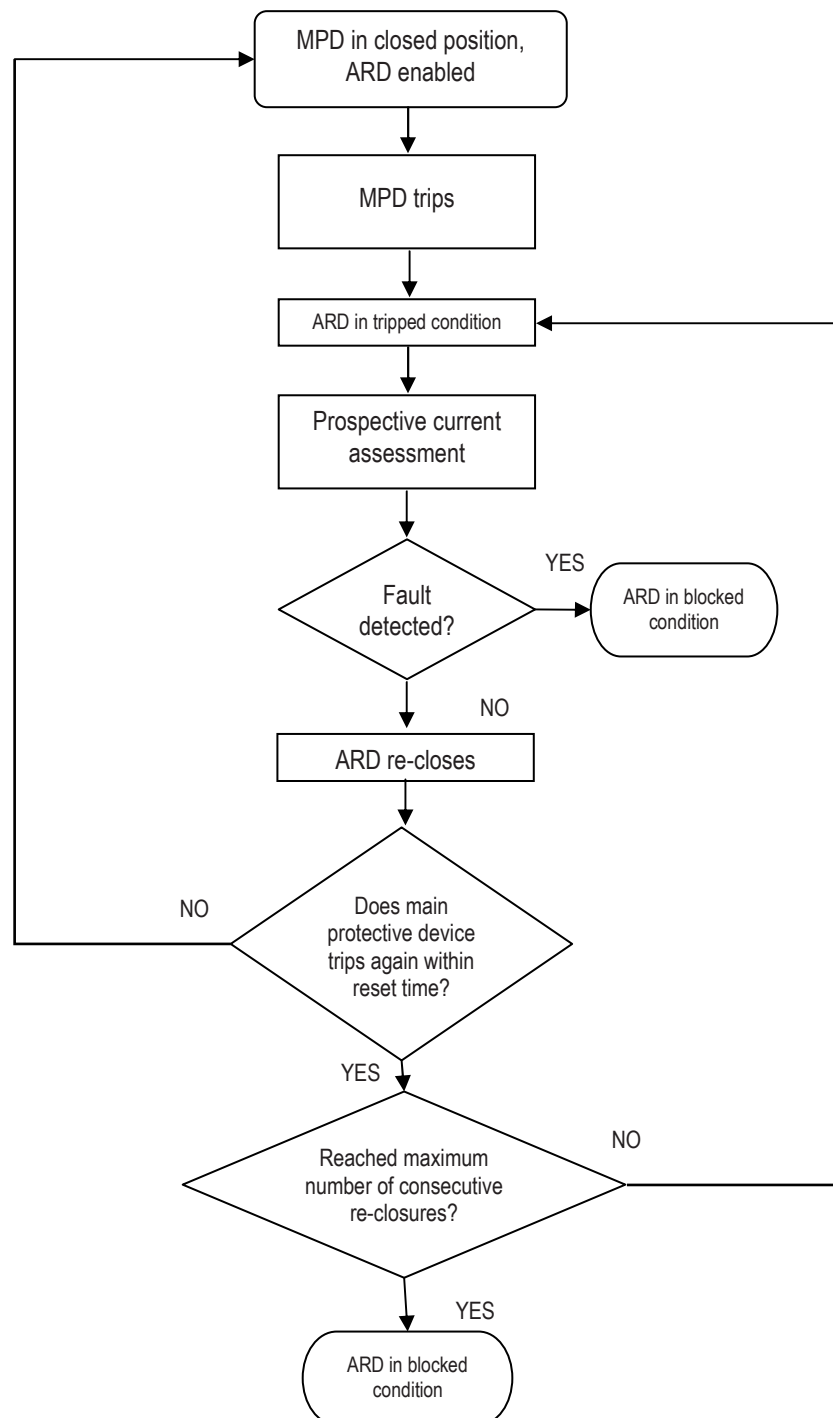


Figure A.1 – Classification of ARDs according to 4.3.1

Annex B
(informative)**Classification of ARDs according to 4.3.2.1 a) and/or 4.3.2.2 a)****Figure B.1 – Classification of ARDs according to 4.3.2.1 a) and/or 4.3.2.2 a)**

Annex C (informative)

Classification of ARDs according to 4.3.2.1 b) and/or 4.3.2.2 b)

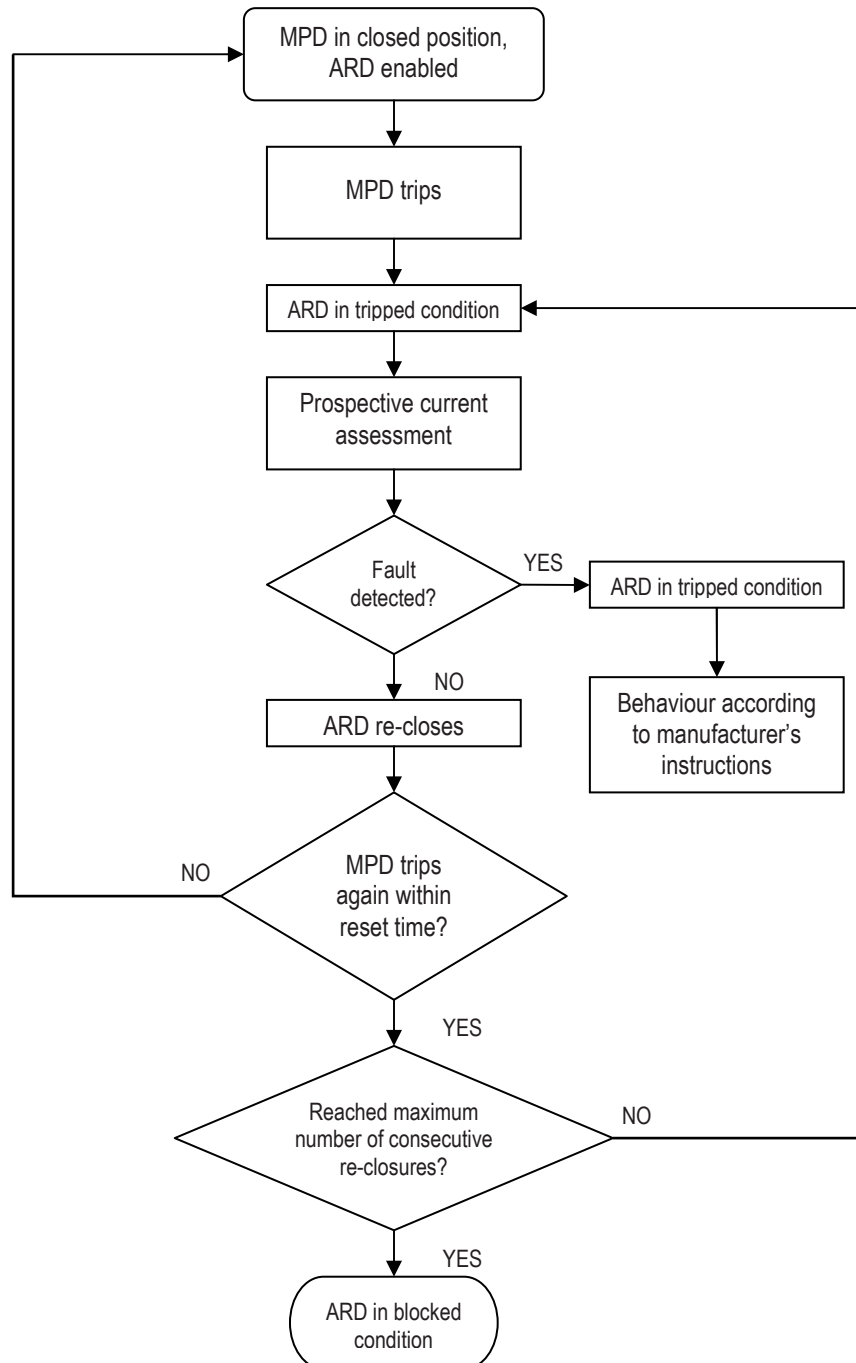


Figure C.1 – Classification of ARDs according to 4.3.2.1 b) and/or 4.3.2.2 b)

Annex D (normative)

Number of samples for full test procedure

Table D.1 – Number of samples for full test procedure

Test sequence	Number of samples
A	1
B	3
C	3
D	3
E	3
F	3
G	3
H	3
I	3

Table D.2 – Additional tests for ARD already fully tested together with one kind of MPD

ARD already tested with	Additional test sequences with other MPD, according to		
	Circuit-breakers	RCBO	RCCB
Circuit-breakers		Clause 6 9.22 9.12 9.19.1 ^a 9.5.2 9.18 ^a	Clause 6 9.22 9.12 9.19.1 ^a 9.5.2 9.18 ^a
RCBO	Clause 6 9.12 9.13 9.5.2		Clause 6 9.12 9.13 9.5.2
RCCB	Clause 6 9.12 9.19.2 ^a 9.13 9.5.2	Clause 6 9.12 9.19.2 ^a 9.13 9.5.2	

^a If applicable.

Annex E (normative)

Test sequences

Table E.1 – Test sequences

Test sequence	Clause or subclause	Test or inspection
A	6	Marking
	9.3	Measurement of the reclosing time after the tripping of the MPD
	8.1.1	General
	8.1.2	Mechanism
	9.4	Indelibility of marking
	8.1.3	Clearance and creepage distances
	9.8	Reliability of screws, current carrying parts and connections
	9.9	Reliability of terminals for external conductors
	9.10	Protection against electric shock
	9.15	Resistance to mechanical shock and impact
	9.16	Resistance to heat
	9.17	Resistance to abnormal heat and to fire
	9.5.2	Verification of the impossibility of the activation of the ARD when the MPD device has been manually opened
	9.5.3	Verification of the enabling and disabling system
9.5.4	Verification of the maximum number of consecutive reclosing	
B	9.11	Test of dielectric properties and isolating capability
	9.12	Temperature rise
	9.19	Verification of operating characteristics
	9.20	Verification of the safety during the assessment
	9.21	Verification of the operation of the test device at the limits of rated voltage
C	9.13	Verification of the mechanical and electrical endurance
D	9.5.1	Verification of operating characteristics of the MPD
	9.14.1.3 a)	Short circuit test (only for ARD classified according to 4.2.1 (circuit-breakers))
	9.14.1.3 b)	Short circuit test (only for ARD classified according to 4.2.2 (RCCBs))
	9.14.2.3 d)	Short circuit test (only for ARD classified according to 4.2.3 (RCBOs))
E	9.14.1.3 c)	Short circuit test (only for ARD classified according to 4.2.2 (RCCBs))
	9.14.1.3 e)	Short circuit test (only for ARD classified according to 4.2.3 (RCBOs))
F	9.22	Reliability
G	9.23	Electromagnetic compatibility
H	9.6 and 9.7	Tests of creepage distances and clearances for electronic circuits
I	9.18	Verification of the correct operation at low ambient air temperatures for RCCBs for use at temperatures between -25 °C and +40 °C

Annex F (informative)

A-deviations

A-deviation: National deviation due to regulations, the alteration of which is for the time being outside the competence of the CEN/CENELEC member.

This European Standard does not fall under any Directive of the EU.

In the relevant CEN/CENELEC countries these A-deviations are valid instead of the provisions of the European Standard until they have been removed.

Deviation	
Country	National Regulation
Denmark	Based on the safety clause in the Danish Heavy Current Regulation, SB 6, and according to the installation practise in Denmark, devices reclosing automatically or remotely operated devices are not permitted for devices for protection against over current and/or electric shock.

Annex ZZ
(informative)

Coverage of Essential Requirements of EU Directives

This European Standard has been prepared under a mandate given to CENELEC by the European Commission and the European Free Trade Association and within its scope the standard covers all relevant essential requirements as given in Article 1 of Annex I of the EU Directive 2004/108/EC.

Compliance with this standard provides one means of conformity with the specified essential requirements of the Directive(s) concerned.

WARNING: Other requirements and other EU Directives may be applicable to the products falling within the scope of this standard.

Bibliography

EN 60085:2008, *Electrical insulation – Thermal evaluation and designation* (IEC 60085:2007)

EN 60695-2-10:2001, *Fire hazard testing – Part 2-10: Glowing/hot-wire based test methods – Glow-wire apparatus and common test procedure* (IEC 60695-2-10:2000)

EN 60998-2-3, *Connecting devices for low-voltage circuits for household and similar purposes – Part 2-3: Particular requirements for connecting devices as separate entities with insulation-piercing clamping units* (IEC 60998-2-3)

HD 60364-6:2007, *Low voltage electrical installations – Part 6: Verification* (IEC 60364-6:2006, mod.)

IEC 60050 series, *International Electrotechnical Vocabulary*

British Standards Institution (BSI)

BSI is the national body responsible for preparing British Standards and other standards-related publications, information and services.

BSI is incorporated by Royal Charter. British Standards and other standardization products are published by BSI Standards Limited.

About us

We bring together business, industry, government, consumers, innovators and others to shape their combined experience and expertise into standards-based solutions.

The knowledge embodied in our standards has been carefully assembled in a dependable format and refined through our open consultation process. Organizations of all sizes and across all sectors choose standards to help them achieve their goals.

Information on standards

We can provide you with the knowledge that your organization needs to succeed. Find out more about British Standards by visiting our website at bsigroup.com/standards or contacting our Customer Services team or Knowledge Centre.

Buying standards

You can buy and download PDF versions of BSI publications, including British and adopted European and international standards, through our website at bsigroup.com/shop, where hard copies can also be purchased.

If you need international and foreign standards from other Standards Development Organizations, hard copies can be ordered from our Customer Services team.

Subscriptions

Our range of subscription services are designed to make using standards easier for you. For further information on our subscription products go to bsigroup.com/subscriptions.

With **British Standards Online (BSOL)** you'll have instant access to over 55,000 British and adopted European and international standards from your desktop. It's available 24/7 and is refreshed daily so you'll always be up to date.

You can keep in touch with standards developments and receive substantial discounts on the purchase price of standards, both in single copy and subscription format, by becoming a **BSI Subscribing Member**.

PLUS is an updating service exclusive to BSI Subscribing Members. You will automatically receive the latest hard copy of your standards when they're revised or replaced.

To find out more about becoming a BSI Subscribing Member and the benefits of membership, please visit bsigroup.com/shop.

With a **Multi-User Network Licence (MUNL)** you are able to host standards publications on your intranet. Licences can cover as few or as many users as you wish. With updates supplied as soon as they're available, you can be sure your documentation is current. For further information, email bsmusales@bsigroup.com.

BSI Group Headquarters

389 Chiswick High Road London W4 4AL UK

Revisions

Our British Standards and other publications are updated by amendment or revision.

We continually improve the quality of our products and services to benefit your business. If you find an inaccuracy or ambiguity within a British Standard or other BSI publication please inform the Knowledge Centre.

Copyright

All the data, software and documentation set out in all British Standards and other BSI publications are the property of and copyrighted by BSI, or some person or entity that owns copyright in the information used (such as the international standardization bodies) and has formally licensed such information to BSI for commercial publication and use. Except as permitted under the Copyright, Designs and Patents Act 1988 no extract may be reproduced, stored in a retrieval system or transmitted in any form or by any means – electronic, photocopying, recording or otherwise – without prior written permission from BSI. Details and advice can be obtained from the Copyright & Licensing Department.

Useful Contacts:

Customer Services

Tel: +44 845 086 9001

Email (orders): orders@bsigroup.com

Email (enquiries): cservices@bsigroup.com

Subscriptions

Tel: +44 845 086 9001

Email: subscriptions@bsigroup.com

Knowledge Centre

Tel: +44 20 8996 7004

Email: knowledgecentre@bsigroup.com

Copyright & Licensing

Tel: +44 20 8996 7070

Email: copyright@bsigroup.com



...making excellence a habit.™