



BSI Standards Publication

Cover plates and cover tapes for the protection and location warning of buried cables or buried conduits in underground installations

NO COPYING WITHOUT BSI PERMISSION EXCEPT AS PERMITTED BY COPYRIGHT LAW

National foreword

This British Standard is the UK implementation of EN 50520:2009.

The UK participation in its preparation was entrusted to Technical Committee PEL/213, Cable management.

A list of organizations represented on this committee can be obtained on request to its secretary.

This publication does not purport to include all the necessary provisions of a contract. Users are responsible for its correct application.

© BSI 2010

ISBN 978 0 580 62074 4

ICS 29.120.10

Compliance with a British Standard cannot confer immunity from legal obligations.

This British Standard was published under the authority of the Standards Policy and Strategy Committee on 31 January 2010

Amendments issued since publication

| Amd. No. | Date | Text affected |
|----------|------|---------------|
|----------|------|---------------|

EUROPEAN STANDARD
NORME EUROPÉENNE
EUROPÄISCHE NORM

EN 50520

July 2009

ICS 29.120.10

English version

Cover plates and cover tapes for the protection and location warning of buried cables or buried conduits in underground installations

Plaques et bandes de protection pour la protection et le signalement des câbles enterrés ou des conduits enterrés dans les installations sous terre

Abdeckplatten und –bänder zum Schutz und zur Warnkennzeichnung der Lage von Kabeln oder erdverlegten Elektroinstallationsrohren in Unterbodeninstallationen

This European Standard was approved by CENELEC on 2009-06-01. CENELEC members are bound to comply with the CEN/CENELEC Internal Regulations which stipulate the conditions for giving this European Standard the status of a national standard without any alteration.

Up-to-date lists and bibliographical references concerning such national standards may be obtained on application to the Central Secretariat or to any CENELEC member.

This European Standard exists in three official versions (English, French, German). A version in any other language made by translation under the responsibility of a CENELEC member into its own language and notified to the Central Secretariat has the same status as the official versions.

CENELEC members are the national electrotechnical committees of Austria, Belgium, Bulgaria, Cyprus, the Czech Republic, Denmark, Estonia, Finland, France, Germany, Greece, Hungary, Iceland, Ireland, Italy, Latvia, Lithuania, Luxembourg, Malta, the Netherlands, Norway, Poland, Portugal, Romania, Slovakia, Slovenia, Spain, Sweden, Switzerland and the United Kingdom.

CENELEC

European Committee for Electrotechnical Standardization
Comité Européen de Normalisation Electrotechnique
Europäisches Komitee für Elektrotechnische Normung

Central Secretariat: Avenue Marnix 17, B - 1000 Brussels

Foreword

This European Standard was prepared by the Technical Committee CENELEC TC 213, Cable management systems.

The text of the draft was submitted to the formal vote and was approved by CENELEC as EN 50520 on 2009-06-01.

The following dates were fixed:

- latest date by which the EN has to be implemented
at national level by publication of an identical
national standard or by endorsement (dop) 2010-06-01
- latest date by which the national standards conflicting
with the EN have to be withdrawn (dow) 2012-06-01

A cover plate or a cover tape which conforms to this European Standard is deemed to be safe for use.

This is a European Standard for cable management products used for electro-technical purposes. It relates to the Council Directives on the approximation of laws, regulations and administrative provisions of the Member States relating to Low Voltage Directive 2006/95/EC through consideration of the essential requirements of this directive.

This European Standard is supported by separate standards to which references are made.

Contents

| | | |
|----|--|----|
| 1 | Scope..... | 4 |
| 2 | Normative references | 4 |
| 3 | Definitions | 4 |
| 4 | General requirements..... | 4 |
| 5 | General conditions for tests..... | 5 |
| 6 | Classification according to the temperature | 5 |
| 7 | Marking and documentation | 6 |
| 8 | Dimensions | 7 |
| 9 | Construction | 7 |
| 10 | Mechanical properties | 7 |
| | Annex A (informative) Test to be applied on the cover plates and cover tapes | 10 |
| | Annex B (informative) Example of the location of the marks..... | 11 |
| | Annex C (informative) Examples of dimensions..... | 12 |
| | Annex D (informative) A-deviations | 13 |
| | Bibliography | 14 |
| | Figures | |
| | Figure 1 - Punch test apparatus | 8 |
| | Figure B.1 - Example of marking for cover plates | 11 |
| | Figure C.1 - Explanation of the meaning of the dimensions of cover plates | 12 |
| | Tables | |
| | Table 1 - Minimum transport, storage installation and application temperature..... | 5 |
| | Table A.1 - Required tests | 10 |
| | Table C.1 - Examples of dimensions of cover plates | 12 |
| | Table C.2 - Examples of dimensions of cover tapes | 12 |

1 Scope

This European Standard establishes the requirements and tests for cover plates and cover tapes used for the mechanical protection, identification and warning of the location of buried cables or buried conduits in underground installations.

NOTE This European Standard does not apply to meshes and tapes falling under EN 12613.

2 Normative references

The following referenced documents are indispensable for the application of this document. For dated references, only the edition cited applies. For undated references, the latest edition of the referenced document (including any amendments) applies.

IEC 60417 (database), *Graphical symbols for use on equipment*

ISO 3864 (series), *Graphical symbols - Safety colours and safety signs*

3 Definitions

For the purpose of this document the following definitions apply.

3.1 cover plates

plates with a defined length and width that are linked one to another and are located above the sand ballast that are intended

- to protect against mechanical damage the underground cables and/or conduit installations, and
- to identify in a prominent manner the location of the underground cables and/or conduit installations along their length and width

3.2 cover tapes

tapes with a defined width that are located above the sand ballast that are intended

- to protect against mechanical damage the underground cables and/or conduit installations, and
- to identify in a prominent manner the location of the underground cables and/or conduit installations along their length and width

4 General requirements

Cover plates and cover tapes shall be so designed and constructed that, when installed according to manufacturer's instructions, they provide mechanical protection and location warning of either a group of cables or conduits in all their extension (length and width).

Compliance is checked by carrying out all the tests specified.

5 General conditions for tests

5.1 Test conditions

Tests according to this standard are type tests.

NOTE Annex A provides an overview of the tests to be applied on the cover plates and cover tapes.

Unless otherwise specified, the samples are tested as delivered and under normal conditions of use, according to the manufacturer's instructions.

Unless otherwise specified, the tests are carried out in the order of the clauses, at an ambient temperature between 15 °C and 35 °C.

In case of doubt, the tests are made at an ambient temperature of (20 ± 5) °C.

5.2 Samples

Unless otherwise specified, each test is made on three new samples.

NOTE Certain tests, for instance the checking of dimensions, do not affect a change in the property of the samples; therefore these samples are considered as new samples and can be used for further tests.

5.3 Validation of the results

The samples are submitted to all the relevant tests and the requirements are satisfied if all the tests are met.

If one sample does not satisfy a test due to an assembly or a manufacturing fault, that test and any preceding one which may have influenced the results of the test shall be repeated, and also the tests which follow shall be carried out in the required sequence on another full set of samples, all of which shall comply with the requirements.

NOTE The applicant may submit, together with a number of samples specified in 5.2, the additional set of samples which may be required, should one sample fail. The testing station will then, without further request, test the additional samples and will only reject them if a further failure occurs. If the additional set of samples is not submitted at the same time, the failure of one sample will entail rejection.

5.4 When toxic or hazardous processes are used, due regard shall be taken of the safety of the persons within the test area.

6 Classification according to the temperature

The minimum temperature of transport, storage, installation and application is given in Table 1.

Table 1 - Minimum transport, storage installation and application temperature

| Temperature °C |
|-------------------|
| +5 |
| -5 |
| -15 |
| -20 |
| -25 |
| -45 |

7 Marking and documentation

7.1 Cover plates and cover tapes shall be marked with

- name, sign or trademark of the manufacturer or responsible vendor,
- a product identification mark which may be, for example, a catalogue number, a symbol or the like,
- the reference to this standard,
- the following notice:
 - a warning, as for example *ATTENTION* or *PRECAUTION*;
 - for cover plates and cover tapes intended for protecting and indicating the presence of electric cables or conduits for electric cables that are buried underground:
the warning sign for dangerous voltage as specified in IEC 60417 (code 5036), inside an advertisement sign as specified in ISO 3864, and the message *ELECTRIC CABLES*;
 - for cover plates and cover tapes intended for protecting and indicating the presence of information and communication technology cables or conduits for information and communication technology cables that are buried underground:
an advertisement sign as specified in ISO 3864, and the message *CABLES*.

Cover plates and cover tapes can voluntarily be marked with:

- the anagram or name of either the supplier electric company or operator of the network;
- any information regarding the used raw material.

NOTE In Annex B an example is given of the marks that are on a cover plate or cover tape.

Compliance is checked by inspection and if necessary by measurement.

7.2 Marking shall be so designed that:

- the text shall be placed in the above part of the cover plates;
- the text shall be in capital letters with a minimum of 15 mm height;
- in cover plates, it shall be possible to read all the marks in a single one;
- in cover tapes the text shall be marked at intervals not exceeding 1 m;
- the text shall present a good contrast with the background colour.

NOTE 1 It is recommended that the marks are to be placed approximately in a central position.

NOTE 2 Examples of safety colours are given in ISO 3864.

Compliance is checked by inspection and if necessary by measurement.

7.3 The marking shall be durable and clearly legible.

Compliance is checked by the following test.

The marking is rubbed by the appropriate method applying a continuous force of 2,5 N for 15 s with a piece of cotton or felt of 20 mm x 35 mm soaked with water and again for 15 s with a piece of cotton or felt of 20 mm x 35 mm soaked with petroleum spirit.

NOTE Marking made by moulding, pressing or engraving is not subjected to this test.

After the test, the marking shall be legible.

8 Dimensions

The dimensions, the profile form and the longitudinal union device shall be according to the manufacturer's standard sheet.

NOTE In Annex C some examples of common dimensions are given.

Compliance is checked by inspection and measurement.

9 Construction

The cut of the ends of the cover plates shall be perpendicular to its longitudinal axis, without sharp edges.

The profile of the cover plates or the cover tapes shall be uniform. It shall be free of irregularities and it shall not have either bubbles or other similar defects.

The junction of cover plates shall be designed in such way that no distance is left between them in the longitudinal axis.

Compliance is checked by inspection.

10 Mechanical properties

10.1 General

Cover plates and cover tapes shall have an adequate mechanical strength.

Compliance is checked by the test of 10.2 and 10.3.

10.2 Punch energy test

The sample will consist on a piece of cover plate or cover tape, as applicable, with a minimum length of 500 mm.

The test is carried out on the sample which shall be placed on a single base of expanded polystyrene, of a density of 15 kg/m³ and of 1 000 mm length, 250 mm width and 100 mm thickness. The polystyrene shall be placed on a soft wooden protector basis.

The hammer, as it is represented in Figure 1, shall fall on the sample from a height of 500 mm ± 5 mm.

The mass of the hammer shall be 10 kg ± 0,01 kg.

Before the test, the samples shall remain for 1 h at the minimum temperature declared by the manufacturer specified in Table 1 with a tolerance of ± 2 °C.

Immediately after taking out the samples of the refrigerating enclosure, it shall be tested 5 times or at least 3 times if the dimensions are too small.

The hammer is allowed to fall on each sample, along the longitudinal axis, at a minimum distance of 100 mm of the longitudinal edges of the sample and at a minimum distance of 100 mm of the point of previous impact. The impacts shall be carried out within 60 s after taking out the samples of the refrigerating enclosure.

In case that after 60 s not all the impacts had been carried out, the sample shall be placed again in the refrigerating enclosure for at least 30 min; after this time, the rest of the impacts shall be carried out.

In the case of a 3 falls test (3 samples and a total of 9 falls), the test is deemed to be passed if, in the group of samples,

- *the hammer penetrates at least two times a maximum distance of 100 mm measured from the top of the sample, and*
- *the samples do not break.*

In the case of a 5 falls test (3 samples and a total of 15 falls), the test is deemed to be passed if, in the group of samples,

- *the hammer penetrates at least three times a maximum distance of 100 mm measured from the top of the sample, and*
- *the samples do not break.*

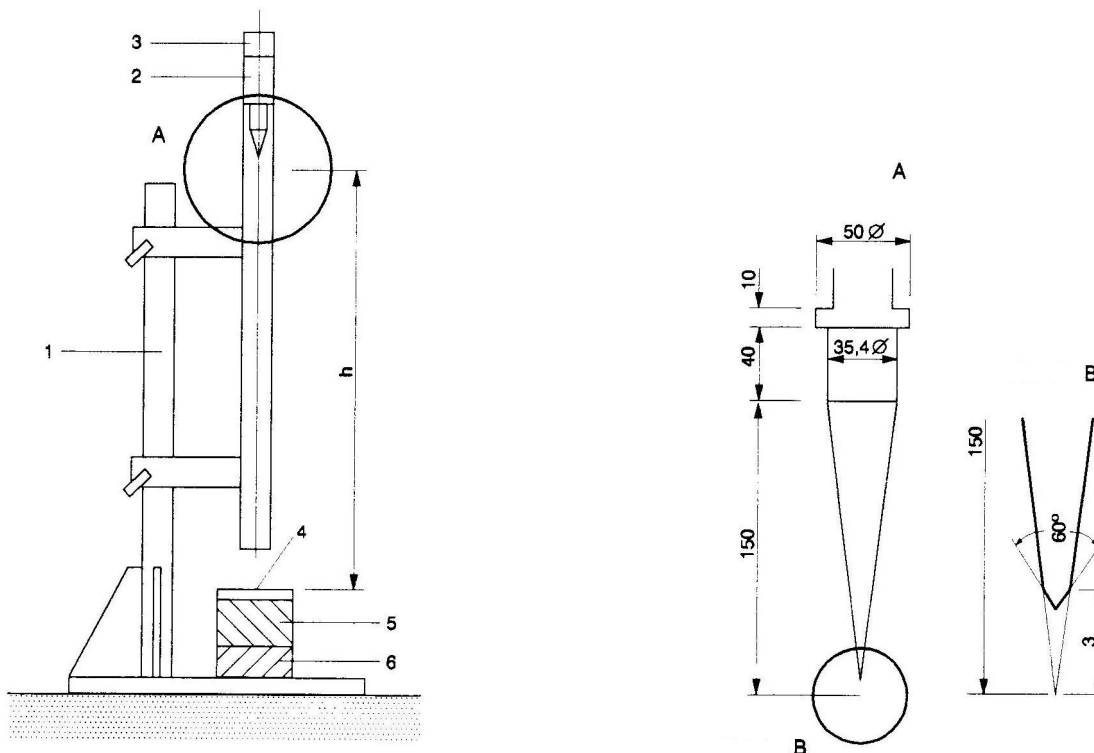

Key

- 1 Adjust column with base plate
- 2 10 kg mass with punch hammer
- 3 Guide
- 4 Sample
- 5 Expanded polystyrene base
- 6 Protective wooden basis
- h Height of the fall

Figure 1 - Punch test apparatus

10.3 Resistance of the longitudinal junction to a tensile strength

When testing cover plates, a piece with a minimum length of 200 mm is cut from each end of the cover plate. Coupling this way the two pieces obtained to form a longitudinal junction.

The sample is submitted to a longitudinal tensile force corresponding to a lengthening speed of a 50 mm/60 s up to a force of at least 100 N.

The test is deemed to be passed if no sample loses the junction.

Annex A
 (informative)

Test to be applied on the cover plates and cover tapes

Table A.1 - Required tests

| Test | Samples | Method and conditions |
|--|---------------|--|
| Verification of the marks | Three samples | Subclause 7.1 Visual examination Measurement |
| Verification of the dimensions of the letters | | Subclause 7.2 Visual examination |
| Verification of the contrast between the text and the background | | Subclause 7.2 Visual examination |
| Indelibility of the marks | | Subclause 7.3 |
| Dimensions | | Clause 8 |
| Construction | | Clause 9 |
| Punch resistance | | Subclause 10.2 |
| Resistance of the longitudinal junction to a tensile strength | | Subclause 10.3 |

Annex B (informative)

Example of the location of the marks

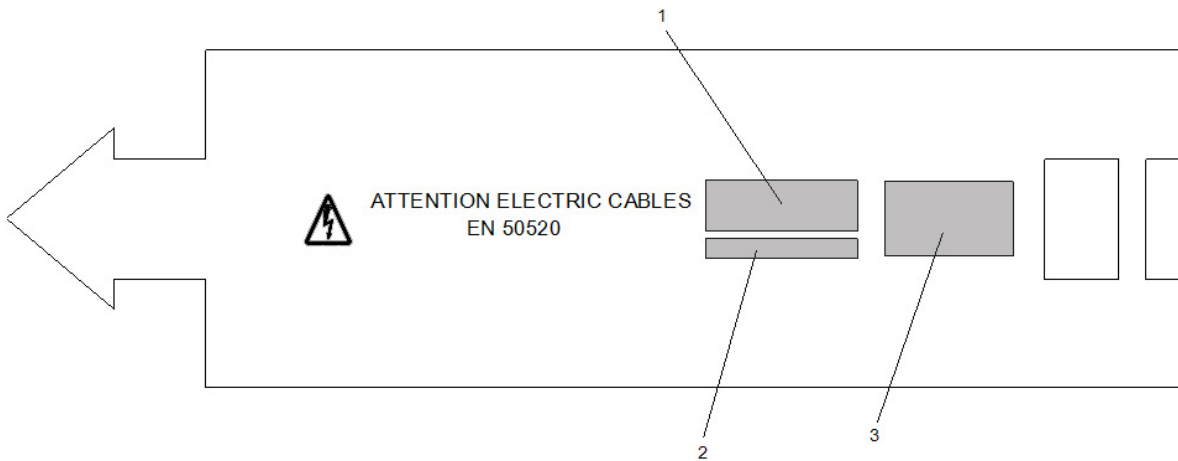

Key

- 1 Name, sign or trademark of the manufacturer or responsible vendor
- 2 Product identification mark
- 3 Anagram or name of either the supplier electric company or operator of the network

Figure B.1 - Example of marking for cover plates

Annex C
 (informative)

Examples of dimensions

Table C.1 - Examples of dimensions of cover plates

| Size of the cover plate mm | A (width) mm | L (length) mm | a mm | b mm |
|-------------------------------|-----------------|------------------|---------|---------|
| 250/500 | 250 | 500 | 50 | 225 |
| 250/1 000 | 250 | 1 000 | 50 | 225 |

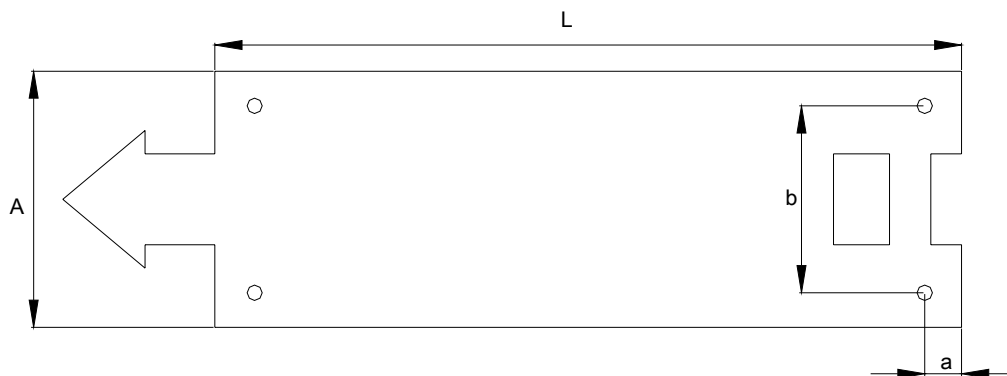

Figure C.1 - Explanation of the meaning of the dimensions of cover plates

Table C.2 - Examples of dimensions of cover tapes

| A (width) mm | L (length) mm |
|-----------------|---|
| 100 up to 400 | Variable, depending on the installation |

Annex D (informative)

A-deviations

A-deviation: National deviation due to regulations, the alteration of which is for the time being outside the competence of the CENELEC member.

This European Standard falls under the LVD Directive 2006/95/EC.

NOTE (from CEN/CENELEC IR Part 2:2006, 2.17) Where standards fall under EC Directives, it is the view of the Commission of the European Communities (OJ No. C 59, 1982-03-09) that the effect of the decision of the Court of Justice in case 815/79 Cremonini/Vrankovich (European Court Reports 1980, p. 3583) is that compliance with A-deviations is no longer mandatory and that the free movement of products complying with such a standard should not be restricted within the EC except under the safeguard procedure provided for in the relevant Directive.

A-deviations in an EFTA-country are valid instead of the relevant provisions of the European Standard in that country until they have been removed.

| <u>Clause</u> | <u>Deviation</u> |
|---------------|------------------|
|---------------|------------------|

| | |
|----------------|--|
| General | Denmark (Heavy Current Regulations SB 35) |
|----------------|--|

Cover plates and cover tapes for the protection and location warning of buried cables or buried conduits in underground installations shall comply with the Danish Heavy Current Regulations SB 35.

Bibliography

EN 12613, *Plastic warning devices for underground cables and pipelines with visual characteristics*

British Standards Institution (BSI)

BSI is the independent national body responsible for preparing British Standards and other standards-related publications, information and services.

It presents the UK view on standards in Europe and at the international level.

It is incorporated by Royal Charter.

Revisions

British Standards are updated by amendment or revision. Users of British Standards should make sure that they possess the latest amendments or editions.

It is the constant aim of BSI to improve the quality of our products and services. We would be grateful if anyone finding an inaccuracy or ambiguity while using this British Standard would inform the Secretary of the technical committee responsible, the identity of which can be found on the inside front cover.

Tel: +44 (0)20 8996 9001 Fax: +44 (0)20 8996 7001

BSI offers Members an individual updating service called PLUS which ensures that subscribers automatically receive the latest editions of standards.

Tel: +44 (0)20 8996 7669 Fax: +44 (0)20 8996 7001

Email: plus@bsigroup.com

Buying standards

You may buy PDF and hard copy versions of standards directly using a credit card from the BSI Shop on the website www.bsigroup.com/shop. In addition all orders for BSI, international and foreign standards publications can be addressed to BSI Customer Services.

Tel: +44 (0)20 8996 9001 Fax: +44 (0)20 8996 7001

Email: orders@bsigroup.com

In response to orders for international standards, it is BSI policy to supply the BSI implementation of those that have been published as British Standards, unless otherwise requested.

Information on standards

BSI provides a wide range of information on national, European and international standards through its Knowledge Centre.

Tel: +44 (0)20 8996 7004 Fax: +44 (0)20 8996 7005

Email: knowledgecentre@bsigroup.com

Various BSI electronic information services are also available which give details on all its products and services.

Tel: +44 (0)20 8996 7111 Fax: +44 (0)20 8996 7048

Email: info@bsigroup.com

BSI Subscribing Members are kept up to date with standards developments and receive substantial discounts on the purchase price of standards. For details of these and other benefits contact Membership Administration.

Tel: +44 (0)20 8996 7002 Fax: +44 (0)20 8996 7001

Email: membership@bsigroup.com

Information regarding online access to British Standards via British Standards Online can be found at www.bsigroup.com/BSOL

Further information about BSI is available on the BSI website at www.bsigroup.com/standards

Copyright

Copyright subsists in all BSI publications. BSI also holds the copyright, in the UK, of the publications of the international standardization bodies. Except as permitted under the Copyright, Designs and Patents Act 1988 no extract may be reproduced, stored in a retrieval system or transmitted in any form or by any means – electronic, photocopying, recording or otherwise – without prior written permission from BSI. This does not preclude the free use, in the course of implementing the standard of necessary details such as symbols, and size, type or grade designations. If these details are to be used for any other purpose than implementation then the prior written permission of BSI must be obtained. Details and advice can be obtained from the Copyright & Licensing Manager.

Tel: +44 (0)20 8996 7070

Email: copyright@bsigroup.com

BSI Group Headquarters

389 Chiswick High Road London W4 4AL UK

Tel +44 (0)20 8996 9001

Fax +44 (0)20 8996 7001

www.bsigroup.com/standards