



BSI Standards Publication

Oil-immersed cable connection assemblies for transformers and reactors having highest voltage for equipment U_m from 72,5 kV to 550 kV

Part 1: Fluid-filled cable terminations

National foreword

This British Standard is the UK implementation of EN 50299-1:2014. Together with BS EN 50299-2:2014, it supersedes BS EN 50299:2002 which will be withdrawn on 13 October 2017.

The UK participation in its preparation was entrusted to Technical Committee PEL/14, Power transformers.

A list of organizations represented on this committee can be obtained on request to its secretary.

This publication does not purport to include all the necessary provisions of a contract. Users are responsible for its correct application.

© The British Standards Institution 2015.
Published by BSI Standards Limited 2015

ISBN 978 0 580 82753 2

ICS 29.180

Compliance with a British Standard cannot confer immunity from legal obligations.

This British Standard was published under the authority of the Standards Policy and Strategy Committee on 31 January 2015.

Amendments/corrigenda issued since publication

Date	Text affected
------	---------------

English Version

Oil-immersed cable connection assemblies for transformers and reactors having highest voltage for equipment U_m from 72,5 kV to 550 kV - Part 1: Fluid-filled cable terminations

Boîte de raccordement de câble pour transformateurs immergés et bobine d'inductance de tensions comprises entre 72,5 kV et 550 kV - Partie 1: Extrémité de câble remplie d'un fluide

Ölgefüllte Kabelanschlusseinheiten für Transformatoren und Drosselspulen mit einer höchsten Spannung für Betriebsmittel U_m von 72,5 kV bis 550 kV - Teil 1: Flüssigkeitsgefüllte Kabelendverschlüsse

This European Standard was approved by CENELEC on 2014-10-13. CENELEC members are bound to comply with the CEN/CENELEC Internal Regulations which stipulate the conditions for giving this European Standard the status of a national standard without any alteration.

Up-to-date lists and bibliographical references concerning such national standards may be obtained on application to the CEN-CENELEC Management Centre or to any CENELEC member.

This European Standard exists in three official versions (English, French, German). A version in any other language made by translation under the responsibility of a CENELEC member into its own language and notified to the CEN-CENELEC Management Centre has the same status as the official versions.

CENELEC members are the national electrotechnical committees of Austria, Belgium, Bulgaria, Croatia, Cyprus, the Czech Republic, Denmark, Estonia, Finland, Former Yugoslav Republic of Macedonia, France, Germany, Greece, Hungary, Iceland, Ireland, Italy, Latvia, Lithuania, Luxembourg, Malta, the Netherlands, Norway, Poland, Portugal, Romania, Slovakia, Slovenia, Spain, Sweden, Switzerland, Turkey and the United Kingdom.



European Committee for Electrotechnical Standardization
Comité Européen de Normalisation Electrotechnique
Europäisches Komitee für Elektrotechnische Normung

CEN-CENELEC Management Centre: Avenue Marnix 17, B-1000 Brussels

Contents

Foreword	3
1 Scope	4
2 Normative references	4
3 Terms and definitions	5
4 Limits of supply	5
5 Rated values	5
6 Preferred values	5
6.1 Highest voltage for equipment (U_m)	5
6.2 Rated currents (I_r)	6
6.3 Transformer test voltages	6
6.4 Transformer test currents	6
6.5 Cable installation test voltage	6
7 Requirements	6
7.1 Connection interface	6
7.2 Mechanical requirements	6
7.3 Dimensions	6
7.4 Protection against corrosion	7
7.5 Mechanical forces on cable terminations	7
8 Tests	7
8.1 Factory tests	7
8.2 Tests after installation	7
Bibliography	11
Figures	
Figure 1 – Limits of supply between transformer and cable termination	8
Figure 2 – Typical arrangement of cable connection assemblies	9

Foreword

This document (EN 50299-1:2014) has been prepared by CLC/TC 14 "Power transformers".

The following dates are fixed:

- latest date by which this document has to be implemented at national level by publication of an identical national standard or by endorsement (dop) 2015-10-13
- latest date by which the national standards conflicting with this document have to be withdrawn (dow) 2017-10-13

This document partially supersedes EN 50299:2002, together with EN 50299-2:2014. Changes have been made in this document to bring it line with EN 50299-2:2014.

Dimensions mentioned in EN 50299-1 are valid for fluid-filled cable terminations. Dry-type cable terminations may also fit to these requirements.

A new standard EN 50299-2 is issued which describes requirements for dry-type cable terminations only.

Attention is drawn to the possibility that some of the elements of this document may be the subject of patent rights. CENELEC [and/or CEN] shall not be held responsible for identifying any or all such patent rights.

1 Scope

This European Standard covers the oil-immersed single-phase connection assembly of cables for transformers and reactors, designed in accordance with EN 60076 series.

NOTE In the standard the term "transformer" is used as common definition for transformer and reactor.

The purpose of EN 50299-1 is to establish for the cable assemblies:

- the electrical and mechanical requirements, including interchangeability;
- the limits of supply;
- the test to be carried out.

It complements and amends, if necessary, the relevant IEC standards and applies to oil immersed cable connections, suitable for fluid-filled or dry-type cable terminations.

EN 50299-1 does not cover direct cable terminations (see 3.1.1.3), but, in this case, upon agreement between purchaser and supplier, the standard may be used for guidance except for Figure 1 and Figure 2 which are not applicable.

This standard applies to oil-immersed cable connection boxes on transformers with highest voltage for equipment $U_m = 72,5$ kV to 550 kV, including the current conductor terminal at the cable sealing end of the transformer.

2 Normative references

The following documents, in whole or in part, are normatively referenced in this document and are indispensable for its application. For dated references, only the edition cited applies. For undated references, the latest edition of the referenced document (including any amendments) applies.

- EN 60076 Series *Power transformers (IEC 60076 Series)*
- EN 60296 *Fluids for electrotechnical applications — Unused mineral insulating oils for transformers and switchgear (IEC 60296)*
- EN ISO 1302 *Geometrical product specifications (GPS) — Indication of surface texture in technical product documentation (ISO 1302)*
- IEC 60141 Series *Tests on oil-filled and gas-pressure cables and their accessories*
- IEC 60840 *Power cables with extruded insulation and their accessories for rated voltages above 30 kV ($U_m = 36$ kV) up to 150 kV ($U_m = 170$ kV) — Test methods and requirements*
- IEC 62067 *Power cables with extruded insulation and their accessories for rated voltages above 150 kV ($U_m = 170$ kV) up to 500 kV ($U_m = 550$ kV) — Test methods and requirements*
- HD 632 S2 *Power cables with extruded insulation and their accessories for rated voltages above 36 kV ($U_m = 42$ kV) up to 150 kV ($U_m = 170$ kV)*

3 Terms and definitions

For the purposes of this document, the following terms and definitions apply.

3.1

cable connection assembly

combination of a cable termination and a cable connection box which mechanically and electrically connects the cable to the transformer

3.1.1

cable termination

equipment fitted to the end of a cable to ensure electrical connection with other parts of the system and to maintain the insulation up to the point of connection

3.1.1.1

fluid-filled cable termination

cable termination which includes an insulating fluid as part of the cable connection assembly and comprises a separation between said cable fluid in the cable connection box

3.1.1.2

dry-type cable termination

cable termination which comprises an elastomeric electrical stress control component in intimate contact with a separating insulating barrier (insulator) between the cable insulation and the liquid insulation of the transformer cable connection box. The cable termination does not require any insulating fluid

3.1.1.3

direct cable termination

cable termination directly fitted on the end of the cable without any separating insulating barrier between the cable insulation and the insulation of the cable connection box. The cable enters directly into the cable box via a gland

3.1.2

cable connection box

part of the transformer which houses the cable termination and the interface to the transformer connection

3.1.2.1

conductor current terminal with removable link

interface to the transformer with removable connection between transformer and socket which allows the transformer to be electrically separated from the cable

4 Limits of supply

The limits of supply of transformer and cable termination shall be according to Figure 1.

5 Rated values

The following rated values shall apply:

- a) highest voltage for equipment (U_m);
- b) rated currents (I_r);
- c) rated short-time and peak withstand currents;
- d) rated duration of short-circuit;
- e) test voltages and test currents for testing the transformer;
- f) test voltage for cable commissioning.

6 Preferred values

6.1 Highest voltage for equipment (U_m)

The highest voltage for equipment U_m of the cable connection shall be equal to the values for the cable and the transformer and shall be selected from the following standard values:

72,5 kV – 100 kV – 123 kV – 145 kV – 170 kV – 245 kV – 300 kV – 362 kV – 420 kV – 550 kV.

6.2 Rated currents (I_r)

Sockets shall be selected with a rated current I_r higher than 1,2 times of the rated current of the transformer. They are qualified without performing additional tests or qualifications, to ensure withstand capability of overloading conditions of transformer according to IEC 60076-7.

The rated current I_r shall be selected from the following standard values which are 20 % higher than the rated current of the transformer:

1 000 A – 1 600 A – 2 000 A – 2 500 A – 3 150 A.

Short-time and peak withstand currents as well as the duration of short circuit shall refer to the levels provided by the cable system, not exceeding the values given in IEC 60076-7 loading guide.

6.3 Transformer test voltages

Transformer test voltages shall conform to EN 60076-3.

6.4 Transformer test currents

Transformer test currents shall conform to IEC 60076-7.

6.5 Cable installation test voltage

The cable installation test voltage shall conform to HD 632 S2, IEC 60840 or IEC 62067.

7 Requirements

7.1 Connection interface

The current-carrying contact surfaces of the connection interface shall be either bare copper or copper silver-coated or tin-coated or silver-coated aluminium. The temperature of this interface shall not exceed the limit given in the standard for the cable for which the cable connection box is designed.

The connection interface is defined in Figure 2.

As the maximum conductor temperature for cables is limited by the maximum operating temperature for the insulation, there are certain cable insulations which cannot withstand the maximum temperature specified for the transformer if there is heat transfer across the connection interface of the cable termination. For cases when the temperature limit given by the IEC standard cannot be achieved, the supplier of the transformer should provide data on temperature rise of the main circuit end terminal and the insulating liquid as function of current.

7.2 Mechanical requirements

The cable connection box shall be oil-tight and with the same degree of vacuum tightness as the transformer.

It shall be filled with degassed oil, normally under vacuum conditions. However, if the transformer tank is not designed to withstand a vacuum, the oil filling shall be carried out under the same conditions as the main transformer tank. The oil used for filling the cable connection box shall comply with the requirements of EN 60296 when sampled after filling and remaining in the box for a period of 20 min to 30 min.

Figure 1 is a sketch of a typical arrangement of a cable termination assembly.

The cable supplier provides the details inside the dotted line. The transformer supplier provides the other details. See also data list.

Figure 1 and Figure 2 show the situation when the cable enters from below. The arrangement can be rotated to allow the cable to enter from above or changed to allow the cable to enter horizontally.

7.3 Dimensions

Figure 1 and Figure 2 show a typical arrangement of a cable connection assembly with entry of the cable from below. Dimensions for cable connection assemblies are defined in Table 1.

The information about surface conditions in Figure 2 is stated in accordance with EN ISO 1302.

NOTE Dimensions, as far as applicable, are harmonised with EN 62271-209:2007, Figure 3.

7.4 Protection against corrosion

The cable connection box shall have the same degree of protection against corrosion as the associated transformer tank.

7.5 Mechanical forces on cable terminations

The cable termination shall be able to withstand a static mechanical force of 2 kN applied transversely to its interface point.

Forces and movements from the transformer can be experienced due to temperature variations and vibrations in service. These forces can act on both transformer and cable termination, and depend largely on transformer layout, termination installation, cable design and methods of mechanical support. The design of any support structure should take into account these forces and movements. It is particularly important that the support for the cable connection box should not be fastened to the clamping flange and/or the cable gland (Figure 1, items 9 and 11).

The cable termination shall be capable of withstanding the vacuum conditions, when the cable connection box is evacuated as part of the liquid filling process of the transformer.

8 Tests

8.1 Factory tests

8.1.1 Check of dimensions

The cable connection box shall comply with the arrangement according to Figure 2 and the dimensions according to Table 1.

8.1.2 Vacuum and pressure tests

One complete cable connection box shall be mounted (with the cable termination replaced by a flange) to demonstrate the same ability to withstand vacuum and pressure as the transformer.

These tests may be performed in conjunction with the vacuum and pressure tests on the transformer.

8.1.3 Dielectric tests

A provisional air-to-oil bushing shall be fitted on the cable connection box (e.g. to the intermediate chamber) to pass dielectric tests of the transformer, with a connection similar to that used in the cable connection box or disconnecting chamber in service.

8.1.4 Mechanical test

A mechanical test shall be performed to prove the requirement given in 7.5.

8.2 Tests after installation

8.2.1 Dielectric tests

The dielectric type tests of the cable termination fitted with a representative cable shall be performed according to HD 632 S2, IEC 60840, IEC 60141 or IEC 62067 in an enclosure filled with transformer oil and with the dimensions given in Figure 2.

In principle, the insulation system of the transformer should not be submitted to DC dielectric stresses, such as those that could be prescribed for cable and relevant termination. Therefore, means should be provided to allow the disconnection of the transformer from the cable (e.g. removable link), unless the transformer supplier accepts that the transformer can be exposed to DC voltage.

If required, the cable termination supplier shall provide a suitable corona shield design for the test after cable installation.

NOTE The cable test may require the installation of electric barriers delivered by the cable termination supplier.

8.2.2 Additional tests

Additional requirements for testing shall be specified by the user in the enquiry.

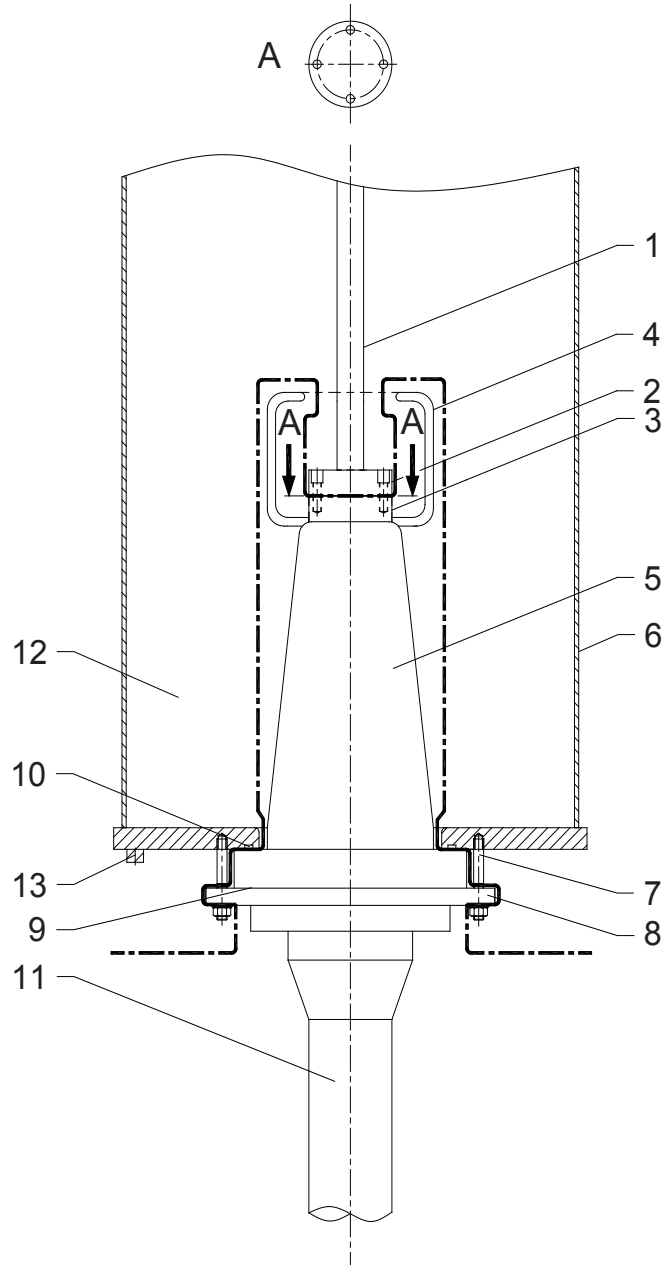

Description	Item	Supplier	
		Trans- former	Cable termination
Conductor current terminal with removable link	1	X	
Connection interface including fixing elements	2	X	
Connection interface	3		X
Shielding electrode ^a	4		X
Cable termination	5		X
Cable connection box	6	X	
Bolts, washers, nuts	7	X	
Clamping flange ^b	8		X
Intermediate gasket ^b	9		X
O-ring seal	10	X	
Cable gland	11		X
Insulating liquid	12	X	
Earthing terminal	13	X	

^a divided or removable because of mounting.
^b if needed.

Figure 1 – Limits of supply between transformer and cable termination

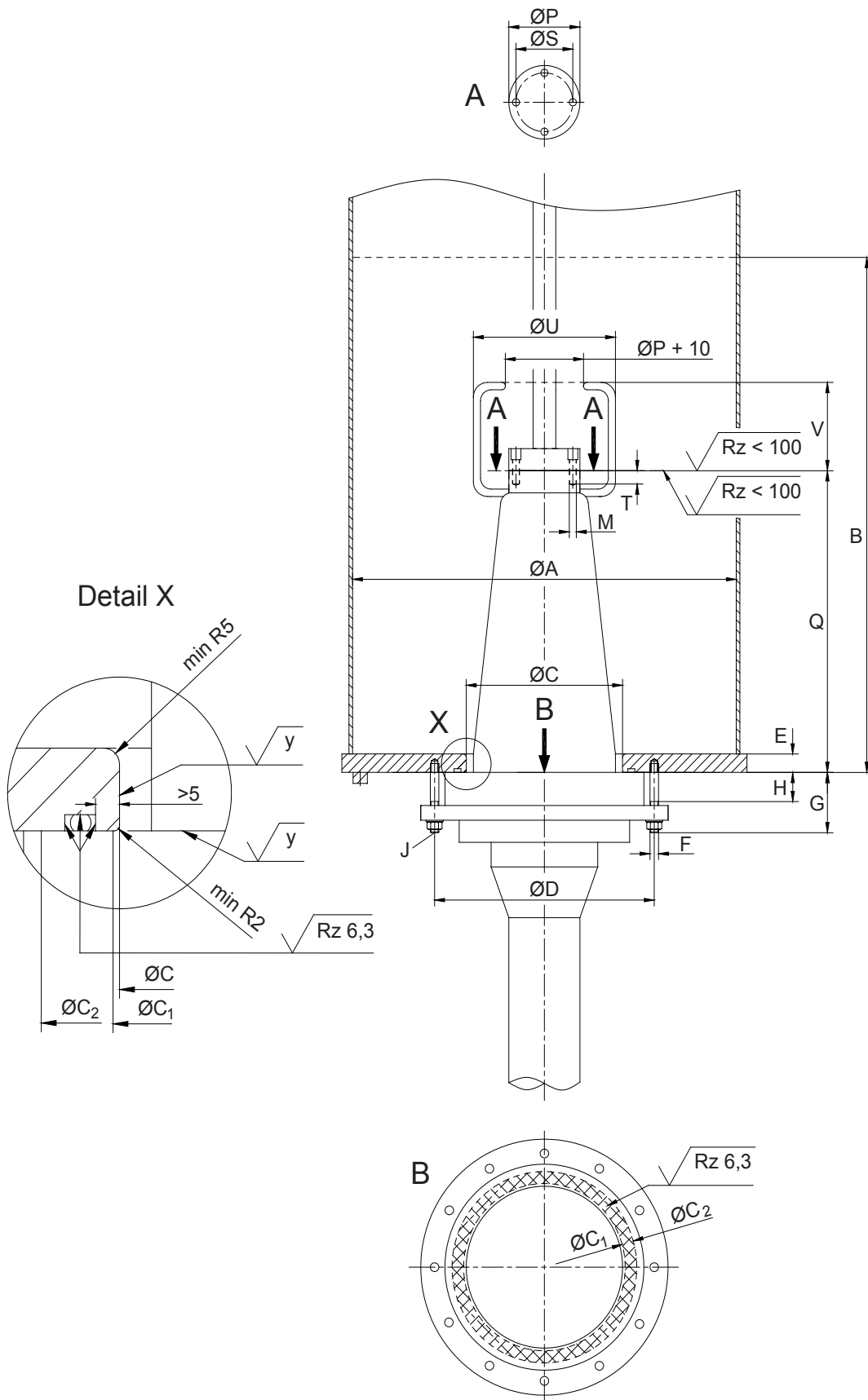

Key

J Number of studs

Figure 2 – Typical arrangement of cable connection assemblies

Table 1 – Dimensions for cable connection assemblies

U_m	kV	72,5	123 - 145	170	245 - 300	362 - 550
LI	kV	325	550 - 650	750	850 – 1 050	1 175 – 1 550
A^a		430 ±3	540 ±3	750 ±3	950 ±3	1 300 ±3
B^b	min	720	900	900	1 130	1 570
C		200 ⁺⁵ ₋₀	255 ⁺⁵ ₋₀	255 ⁺⁵ ₋₀	480 ⁺⁵ ₋₀	540 ⁺⁵ ₋₀
C_1^c	max	206	266	266	491	551
C_2^c	min	242	295	295	555	613
D		270 ^{+0,5} _{-0,5}	320 ^{+0,5} _{-0,5}	320 ^{+0,5} _{-0,5}	582 ^{+0,5} _{-0,5}	640 ^{+0,5} _{-0,5}
E	max	25	30	30	35	35
F^d		M10 35 Nm	M12 45 Nm	M12 45 Nm	M16 50 Nm	M16 50 Nm
G	min	90	90	90	110	110
H	max	30	30	30	30	30
J		8	12	12	16	20
M^d		4 x M10 35 Nm	4 x M10 35 Nm	4 x M10 35 Nm	4 x M12 50 Nm	4 x M12 50 Nm
P	min	100	100	100	140	140
Q		583 ⁺¹ ₋₁	757 ⁺¹ ₋₁	757 ⁺¹ ₋₁	960 ⁺² ₋₂	1 400 ⁺² ₋₂
S		80 ^{+0,3} _{-0,3}	80 ^{+0,3} _{-0,3}	80 ^{+0,3} _{-0,3}	110 ^{+0,3} _{-0,3}	110 ^{+0,3} _{-0,3}
T	min	18	18	18	21	21
U	max	218	218	218	350	500
V		120 ⁺⁵ ₋₅	120 ⁺⁵ ₋₅	120 ⁺⁵ ₋₅	160 ⁺⁵ ₋₅	160 ⁺⁵ ₋₅

^a Deviating shape for the cable connection box is possible. The minimum allowed distance from center line of socket to grounded parts is $A/2$.

^b Minimum distance to get the minimum clearance between shielding electrode and grounded parts.

^c Inner diameter C_1 and outer diameter C_2 of sealing surface of socket.

^d Bolt size and typical tightening torque of bolted joint.

Bibliography

EN 62271-209:2007; *High-voltage switchgear and controlgear — Part 209: Cable Connections for gas-insulated metal-enclosed switchgear for rated voltages above 52 kV — Fluid-filled and extruded insulation cables — Fluid-filled and dry-type cable-terminations (IEC 62271-209:2007)*

British Standards Institution (BSI)

BSI is the national body responsible for preparing British Standards and other standards-related publications, information and services.

BSI is incorporated by Royal Charter. British Standards and other standardization products are published by BSI Standards Limited.

About us

We bring together business, industry, government, consumers, innovators and others to shape their combined experience and expertise into standards-based solutions.

The knowledge embodied in our standards has been carefully assembled in a dependable format and refined through our open consultation process. Organizations of all sizes and across all sectors choose standards to help them achieve their goals.

Information on standards

We can provide you with the knowledge that your organization needs to succeed. Find out more about British Standards by visiting our website at bsigroup.com/standards or contacting our Customer Services team or Knowledge Centre.

Buying standards

You can buy and download PDF versions of BSI publications, including British and adopted European and international standards, through our website at bsigroup.com/shop, where hard copies can also be purchased.

If you need international and foreign standards from other Standards Development Organizations, hard copies can be ordered from our Customer Services team.

Subscriptions

Our range of subscription services are designed to make using standards easier for you. For further information on our subscription products go to bsigroup.com/subscriptions.

With **British Standards Online (BSOL)** you'll have instant access to over 55,000 British and adopted European and international standards from your desktop. It's available 24/7 and is refreshed daily so you'll always be up to date.

You can keep in touch with standards developments and receive substantial discounts on the purchase price of standards, both in single copy and subscription format, by becoming a **BSI Subscribing Member**.

PLUS is an updating service exclusive to BSI Subscribing Members. You will automatically receive the latest hard copy of your standards when they're revised or replaced.

To find out more about becoming a BSI Subscribing Member and the benefits of membership, please visit bsigroup.com/shop.

With a **Multi-User Network Licence (MUNL)** you are able to host standards publications on your intranet. Licences can cover as few or as many users as you wish. With updates supplied as soon as they're available, you can be sure your documentation is current. For further information, email bsmusales@bsigroup.com.

BSI Group Headquarters

389 Chiswick High Road London W4 4AL UK

Revisions

Our British Standards and other publications are updated by amendment or revision.

We continually improve the quality of our products and services to benefit your business. If you find an inaccuracy or ambiguity within a British Standard or other BSI publication please inform the Knowledge Centre.

Copyright

All the data, software and documentation set out in all British Standards and other BSI publications are the property of and copyrighted by BSI, or some person or entity that owns copyright in the information used (such as the international standardization bodies) and has formally licensed such information to BSI for commercial publication and use. Except as permitted under the Copyright, Designs and Patents Act 1988 no extract may be reproduced, stored in a retrieval system or transmitted in any form or by any means – electronic, photocopying, recording or otherwise – without prior written permission from BSI. Details and advice can be obtained from the Copyright & Licensing Department.

Useful Contacts:

Customer Services

Tel: +44 845 086 9001

Email (orders): orders@bsigroup.com

Email (enquiries): cservices@bsigroup.com

Subscriptions

Tel: +44 845 086 9001

Email: subscriptions@bsigroup.com

Knowledge Centre

Tel: +44 20 8996 7004

Email: knowledgecentre@bsigroup.com

Copyright & Licensing

Tel: +44 20 8996 7070

Email: copyright@bsigroup.com



...making excellence a habit.™