

BS EN 50083-2:2012

BSI Standards Institution 2012

Version correct as of 31/08/2012 01:14

© The British Standards Institution 2012



BSI Standards Publication

Cable networks for television signals, sound signals and interactive services

Part 2: Electromagnetic compatibility for equipment

NO COPYING WITHOUT BSI PERMISSION EXCEPT AS PERMITTED BY COPYRIGHT LAW

raising standards worldwide™



National foreword

This British Standard is the UK implementation of EN 50083-2:2012. It supersedes BS EN 50083-2:2006 which is withdrawn.

The UK participation in its preparation was entrusted to Technical Committee EPL/100/4, Cable distribution equipment and systems.

A list of organizations represented on this committee can be obtained on request to its secretary.

This publication does not purport to include all the necessary provisions of a contract. Users are responsible for its correct application.

© The British Standards Institution 2012. Published by BSI Standards Limited 2012

ISBN 978 0 580 76162 1

ICS 33.060.40; 33.100.01

Compliance with a British Standard cannot confer immunity from legal obligations.

This British Standard was published under the authority of the Standards Policy and Strategy Committee on 31 May 2012.

Amendments issued since publication

Date	Text affected
------	---------------

EUROPEAN STANDARD
NORME EUROPÉENNE
EUROPÄISCHE NORM

EN 50083-2

March 2012

ICS 33.060.40

Supersedes EN 50083-2:2006

English version

**Cable networks for television signals, sound signals and interactive services -
Part 2: Electromagnetic compatibility for equipment**

Réseaux de distribution par câbles pour signaux de télévision, signaux de radiodiffusion sonore et services interactifs -
Partie 2: Compatibilité électromagnétique pour les matériels

Kabelnetze für Fernsehsignale, Tonsignale und interaktive Dienste -
Teil 2: Elektromagnetische Verträglichkeit von Geräten

This European Standard was approved by CENELEC on 2011-12-21. CENELEC members are bound to comply with the CEN/CENELEC Internal Regulations which stipulate the conditions for giving this European Standard the status of a national standard without any alteration.

Up-to-date lists and bibliographical references concerning such national standards may be obtained on application to the CEN-CENELEC Management Centre or to any CENELEC member.

This European Standard exists in three official versions (English, French, German). A version in any other language made by translation under the responsibility of a CENELEC member into its own language and notified to the CEN-CENELEC Management Centre has the same status as the official versions.

CENELEC members are the national electrotechnical committees of Austria, Belgium, Bulgaria, Croatia, Cyprus, the Czech Republic, Denmark, Estonia, Finland, France, Germany, Greece, Hungary, Iceland, Ireland, Italy, Latvia, Lithuania, Luxembourg, Malta, the Netherlands, Norway, Poland, Portugal, Romania, Slovakia, Slovenia, Spain, Sweden, Switzerland, Turkey and the United Kingdom.

CENELEC

European Committee for Electrotechnical Standardization
Comité Européen de Normalisation Electrotechnique
Europäisches Komitee für Elektrotechnische Normung

Management Centre: Avenue Marnix 17, B - 1000 Brussels

Contents

Contents	2
Foreword	5
1 Scope	7
1.1 General	7
1.2 Specific scope of EN 50083-2	7
2 Normative references	9
3 Terms, definitions, symbols and abbreviations	10
3.1 Terms and definitions	10
3.2 Symbols	15
3.3 Abbreviations	16
4 Methods of measurements	16
4.1 General operating conditions	16
4.2 Disturbance voltages from equipment	17
4.3 Radiation from active equipment	18
4.4 Immunity of active equipment	28
4.5 Screening effectiveness of passive equipment	40
4.6 Electrostatic discharge immunity test for active equipment	42
4.7 Electrical fast transient/burst immunity test for AC power ports	42
4.8 Methods of measurement for telecom signal ports of multimedia network equipment	42
4.9 Measurement of indoor receiving antennas for broadcast signals	42
5 Performance requirements	43
5.1 General	43
5.2 Disturbance voltages from equipment	43
5.3 Radiation	44
5.4 Immunity of active equipment	45
5.5 Screening effectiveness of passive equipment	51
5.6 Electrostatic discharge immunity test for active equipment	52
5.7 Electrical fast transient/burst immunity test for AC power ports	52
5.8 Performance requirements for telecom signal ports of multimedia network equipment	52
5.9 Applicability of EMC performance requirements and methods of measurement to different types of equipment	52
Annex ZZ (informative) Coverage of Essential Requirements of EU Directives	55
Bibliography	56

Figures

Figure 1 - Measurement set-up for radiation measurements in the frequency range 5 MHz to 30 MHz using the "coupling unit" method.....	21
Figure 2 - Absorbing clamp method (30 MHz to 1 000 MHz)	23
Figure 3 - Example of general measurement set-up	24
Figure 4 - Example of measurement set-up for measurements on the input port of an active equipment	24
Figure 5 - Measurement set-up for the "substitution" radiation method – First measurement step	26
Figure 6 - Measurement set-up for the "substitution" radiation method – Second measurement step	27
Figure 7 - Frequency allocation for out-of-band immunity measurement of active equipment with nominal upper frequency limit $\leq 1\,000$ MHz.....	30
Figure 8 - Frequency allocation for out-of-band immunity measurement of active equipment with nominal lower frequency limit ≥ 950 MHz	30
Figure 9 - Frequency allocation for in-band immunity measurement of active equipment with nominal upper frequency limit $\leq 1\,000$ MHz	33
Figure 10 - Frequency allocation for in-band immunity measurement of active equipment with nominal lower frequency limit ≥ 950 MHz	33
Figure 11 - Measurement set-up for internal immunity test.....	35
Figure 12 - Levels of wanted and unwanted signals for the internal immunity of FSS receiving outdoor units	38
Figure 13 - Levels of wanted and unwanted signals for the internal immunity of BSS receiving outdoor units	39
Figure 14 - Levels of unwanted signals for the internal immunity of active equipment in Band I (47 MHz to 68 MHz).....	47
Figure 15 - Levels of unwanted signals for the internal immunity of active equipment in Band II (87,5 MHz to 108 MHz)	48
Figure 16 - Levels of unwanted signals for the internal immunity of active equipment in Band III (174 MHz to 230 MHz)	49
Figure 17 - Levels of unwanted signals for the internal immunity of active equipment in Band IV/V (470 MHz to 862 MHz)	50

Tables

Table 1 - Port structure of different network equipment	8
Table 2 - Limits of mains terminal disturbance voltage	43
Table 3 - Limits of input terminal disturbance voltages for equipment directly connected to receiving antennas	44
Table 4 - Limits of input terminal disturbance voltages for equipment directly connected to satellite outdoor units	44
Table 5 - Limits of radiated disturbance power	44
Table 6 - Limit of local oscillator terminal power	45
Table 7 - Limits of out-of-band immunity	45
Table 8 - Limits of in-band immunity	46
Table 9 - Test specification for internal immunity	46
Table 10 - Limits of immunity to image frequency signals in terms of image suppression ratio	51
Table 11 - Limits of screening effectiveness of passive equipment within the nominal frequency ranges	51
Table 12 - Test specifications for electrostatic discharge immunity test for active equipment	52
Table 13 - Test specifications for electrical fast transient/burst immunity test	52
Table 14 - Port types and environmental conditions for EMC performance requirements and methods of measurement	52
Table 15 - Emission parameters	53
Table 16 - Immunity and screening effectiveness parameters	54

Foreword

This document (EN 50083-2:2012) has been prepared by CLC/TC 209 "Cable networks for television signals, sound signals and interactive services".

The following dates are fixed:

- latest date by which this document has to be implemented at national level by publication of an identical national standard or by endorsement (dop) 2012-12-21
- latest date by which the national standards conflicting with this document have to be withdrawn (dow) 2013-06-21

This document supersedes EN 50083-2:2006.

EN 50083-2:2012 includes the following significant technical changes with respect to EN 50083-2:2006:

1. Frequency extensions

- 1.1. The upper frequency limit of conventional cable network equipment was extended from 862 MHz to 1 000 MHz due to market demands.
- 1.2. The first intermediate frequency range (1st IF range) for satellite signal transmission was extended to cover now frequencies from 950 MHz up to 3 500 MHz.
- 1.3. The methods of measurement and the EMC requirements in the overlapping frequency range from 950 MHz to 1 000 MHz were allocated in relation to the upper frequency limit, 1 000 MHz, respectively the lower frequency limit, 950 MHz, of the relevant equipment under test.

2. New EMC environment in the 800 MHz band

- 2.1. The European Commission has requested CENELEC and ETSI to draft immunity requirements for equipment, to protect against disturbance from the new wireless service in the 790-862 MHz band.
- 2.2. A CENELEC/ETSI Joint Working Group "Digital Dividend" was formed to describe the new EMC environment and to advise on appropriate test methods and limits.
- 2.3. EN 50083-2 is the standard specifying immunity requirements for active and passive cable network equipment.
- 2.4. The method of measurement and the requirements for in-band immunity were extended taking into account this new EMC environment due to the allocation of broadband wireless services in the frequency band 790 MHz to 862 MHz. As a consequence, the limits of in-band immunity were specified for analogue and additionally for digital signals in this frequency range.
- 2.5. Consequently it is recommended, that, where cable networks and wireless networks coexist, only the transmission of digitally modulated signals should be used in the frequency range 790 MHz to 862 MHz.
- 2.6. For passive equipment, Class A and Class B specifications were kept in the standard but a note was added recommending that only Class A equipment should be used in the planning and implementation of new networks.

3. Indoor antennas

The methods of measurement for all kinds of indoor antennas were combined in the new 4.9.

4. Bibliography

A Bibliography was added at the end of the document referencing i.a. to CEPT Report 30 on “*The identification of common and minimal (least restrictive) technical conditions for 790-862 MHz for the digital dividend in the European Union*”.

Attention is drawn to the possibility that some of the elements of this document may be the subject of patent rights. CENELEC [and/or CEN] shall not be held responsible for identifying any or all such patent rights.

This document has been prepared under a mandate given to CENELEC by the European Commission and the European Free Trade Association, and supports essential requirements of EU Directive(s).

For the relationship with EU Directive(s) see informative Annex ZZ, which is an integral part of this document

1 Scope

1.1 General

Standards of the EN 50083 and EN 60728 series deal with cable networks including equipment and associated methods of measurement for headend reception, processing and distribution of television signals, sound signals and their associated data signals and for processing, interfacing and transmitting all kinds of signals for interactive services using all applicable transmission media.

This includes

- CATV-networks ¹⁾,
- MATV-networks and SMATV-networks,
- individual receiving networks

and all kinds of equipment, systems and installations installed in such networks.

The extent of this standardisation work is from the antennas and/or special signal source inputs to the headend or other interface points to the network up to the terminal input.

The standardisation of any user terminals (i.e., tuners, receivers, decoders, multimedia terminals, etc.) as well as of any coaxial, balanced and optical cables and accessories thereof is excluded.

1.2 Specific scope of EN 50083-2

This European Standard

- applies to the radiation characteristics and immunity to electromagnetic disturbance of EM-active equipment (active and passive equipment) for the reception, processing and distribution of television, sound and interactive multimedia signals as dealt with in the following parts of EN 50083 or EN 60728 series:
 - EN 60728-3 "Active wideband equipment for cable networks";
 - EN 60728-4 "Passive wideband equipment for coaxial cable networks";
 - EN 60728-5 "Headend equipment";
 - EN 60728-6 "Optical equipment";
- covers the following frequency ranges:

disturbance voltage injected into the mains	150 kHz to 30 MHz;	
radiation from active equipment	5 MHz to 25 GHz;	
immunity of active equipment	150 kHz to 25 GHz ²⁾ ;	
screening effectiveness of passive equipment	5 MHz to 3,5 GHz	(25 GHz) ³⁾ ;

¹⁾ 'CATV-networks' encompasses the HFC networks used nowadays to provide telecommunications services, voice, data, audio and video both broadcast and narrowcast.

²⁾ For „Inband immunity of active equipment“ and „Out-of-band immunity of active equipment, no requirements apply at present for the frequency range 3,5 GHz to 25 GHz. Methods of measurement and limits are investigated for inclusion in a future amendment or revised edition.

³⁾ For "Screening effectiveness of passive equipment", no requirements apply at present for the frequency range 3,5 GHz to 25 GHz. Methods of measurement and limits are investigated for inclusion in a future amendment or revised edition.

- specifies requirements for maximum allowed radiation, minimum immunity and minimum screening effectiveness;
- describes test methods for conformance testing.

No measurement needs to be performed at frequencies where no requirement is specified.

Due to the fact that cable networks, the former cabled distribution systems for television and sound signals are more and more used for interactive services, these networks may incorporate also equipment that carry besides the cable network equipment ports also one or more telecom signal port(s). This equipment shall be named as "multimedia network equipment".

The EMC behaviour of cable network equipment, telecommunication network equipment and multimedia network equipment may be described by the following port structure (Table 1):

Table 1 - Port structure of different network equipment

Port name	Cable network equipment	Telecommunication network equipment	Multimedia network equipment
Enclosure	X	X	X
Earth	X	X	X
AC/DC power supply	X	X	X
Control (e.g. alarm)	X	X	X
Antenna input port	X		X
RF network port	X		X
Telecom signal port		X	X

Table 1 shows that cable network equipment and telecommunication network equipment have four common ports and, respectively, two and one individual ports. Multimedia network equipment carry besides the common ports an antenna input port and/or a RF network port as well as a telecom signal port.

The electromagnetic compatibility requirements for "telecommunication network equipment only" are standardised in ETSI EN 300 386 (mainly) and in ETSI EN 301 489-4, those for "cable network equipment only" are given in this EN 50083-2.

Equipment for multimedia networks of the above-mentioned type has to work under the same EMC conditions as equipment that is falling under the cable network and the telecommunication network EMC-standards. Due to the fact, that this equipment has to work in close proximity, e.g. in the same operating room, the EMC environmental conditions for all three types of equipment are the same.

This means that multimedia network equipment has to fulfil the EMC requirements of one of the above mentioned standards and in addition the EMC requirements, laid down in the other EMC standard, for the additional port, by which it is connected to the other network.

By this procedure it is ensured that multimedia network equipment fulfils the EMC conditions of one of the above mentioned networks and will neither disturb the respective other system nor will be disturbed by the respective other system via the connecting port.

Coaxial cables for cable networks do not fall under the scope of this standard; reference is made to EN 50117 series. Coaxial cable assemblies for radio and TV receivers (receiver leads) do not fall under the scope of this standard; reference is made to EN 60966 series. Requirements for the electromagnetic compatibility of receiver leads are laid down in EN 60966-2-4, EN 60966-2-5 and EN 60966-2-6.

This European Standard also covers indoor receiving antennas for broadcast signals for which the requirements and the applicable methods of measurement are limited to the emission and the electrostatic discharge phenomena.

Standardisation in the field of "Electromagnetic compatibility" for any broadcast terminals (e.g. tuners, receivers, decoders, etc.) is covered by EN 55013 and EN 55020 and for multimedia terminals by EN 55022 and EN 55024.

2 Normative references

The following documents, in whole or in part, are normatively referenced in this document and are indispensable for its application. For dated references, only the edition cited applies. For undated references, the latest edition of the referenced document (including any amendments) applies.

EN 55013	2001	Sound and television broadcast receivers and associated equipment – Radio disturbance characteristics – Limits and methods of measurement (CISPR 13:2001+A1:2003+A2:2006)
+A1	2003	
+A2	2006	
+IS1	2009	
EN 55016-1-1	2010	Specification for radio disturbance and immunity measuring apparatus and methods – Part 1-1: Radio disturbance and immunity measuring apparatus – Measuring apparatus (CISPR 16-1-1:2010 + corrigendum 2011 + A1:2010)
+A1	2010	
EN 55020	2007	Sound and television broadcast receivers and associated equipment – Immunity characteristics – Limits and methods of measurement (CISPR 20:2006)
+IS1	2009	
+IS2	2010	
+A11	2011	
EN 60728-3	2011	Cable networks for television signals, sound signals and interactive services – Part 3: Active wideband equipment for cable networks (IEC 60728-3: 2010)
EN 61000-3-2	2006	Electromagnetic compatibility (EMC) – Part 3-2: Limits – Limits for harmonic current emissions (equipment input current ≤ 16 A per phase) (IEC 61000-3-2:2005 + A1:2008 + A2:2009)
+A1	2009	
+A2	2009	
EN 61000-4-2	2009	Electromagnetic compatibility (EMC) – Part 4-2: Testing and measurement techniques – Electrostatic discharge immunity test (IEC 61000-4-2:2008)
EN 61000-4-3	2006	Electromagnetic compatibility (EMC) – Part 4-3: Testing and measurement techniques – Radiated, radio-frequency, electromagnetic field immunity test (IEC 61000-4-3:2006 +A1:2007 + A2:2010)
+A1	2008	
+A2	2010	
+IS1	2009	
EN 61000-4-4	2004	Electromagnetic compatibility (EMC) – Part 4-4: Testing and measurement techniques – Electrical fast transient/burst immunity test (IEC 61000-4-4:2004 + A1:2010)
+A1	2010	
EN 61000-4-6	2009	Electromagnetic compatibility (EMC) – Part 4-6: Testing and measurement techniques – Immunity to conducted disturbances, induced by radio-frequency fields (IEC 61000-4-6:2008)
EN 61000-6-1	2007	Electromagnetic compatibility (EMC) – Part 6-1: Generic standards – Immunity for residential, commercial and light-industrial environments (IEC 61000-6-1:2005)
EN 61079-1	1993	Methods of measurement on receivers for satellite broadcast transmissions in the 12 GHz band – Part 1: Radiofrequency measurements on outdoor units (IEC 61079-1:1992)

ETSI EN 300 386 V1.5.1	2010	Electromagnetic compatibility and Radio spectrum Matters (ERM); Telecommunication network equipment; ElectroMagnetic Compatibility (EMC) requirements
IEC 60050-161 +A1	1990 1997	International Electrotechnical Vocabulary (IEV) Chapter 161: Electromagnetic compatibility
+A2	1998	

3 Terms, definitions, symbols and abbreviations

3.1 Terms and definitions

For the purposes of this document, the terms and definitions given in IEC 60050-161:1990 and the following apply.

Note 1 to entry: The most important definitions of IEC 60050-161:1990 are repeated hereafter with the IEC-numbering given in brackets. In addition, some more specific definitions, used in this standard, are listed.

3.1.1

AC power port

point at which a cable for the AC power supply is connected to the equipment

3.1.2

active equipment

equipment (e.g. amplifiers, converters, etc.), performing signal processing by means of external or internal power supply in a certain frequency range

3.1.3

antenna input port

point at which the equipment under test is directly connected to the receiving antenna(s)

3.1.4

band

nominal operating frequency range of the equipment

3.1.5

burst (of pulses or oscillations)

sequence of a limited number of distinct pulses or an oscillation of limited duration

[SOURCE: IEC 161-02-07]

3.1.6

cable network equipment

equipment from which cable networks for television signals, sound signals and interactive services are built

Note 1 to entry: Examples of typical cable network equipment could be found in EN 60728-3, EN 60728-4, EN 60728-5, EN 60728-6 and EN 60728-10.

3.1.7

carrier-to-interference ratio

minimum level difference measured at the output of an active equipment between the wanted signal and

- intermodulation products of the wanted signal and/or unwanted signals generated due to non-linearities,
- harmonics generated by an unwanted signal,
- unwanted signals that have penetrated into the operating frequency range,

- unwanted signals that have been converted to the frequency range to be protected (operating frequency range)

3.1.8

control port

point at which a cable for the control signal is connected to the equipment

3.1.9

DC power port

point at which a cable for the DC power supply is connected to the equipment

3.1.10

DOCSIS

Data-Over-Cable Service Interface Specification

standard defining interface specifications for cable modems and cable modem termination systems for high-speed data communication over cable networks

Note 1 to entry: DOCSIS contains a European technology option commonly known as EuroDOCSIS that accommodates the cable spectrum planning practices and channel plans mainly deployed in European cable networks.

3.1.11

electromagnetic-active equipment

passive and active equipment carrying RF signals that are considered as electromagnetic-active equipment because they are liable to cause electromagnetic disturbances or the performance of them is liable to be affected by such disturbances

3.1.12

electromagnetic disturbance

electromagnetic phenomenon which may degrade the performance of a device, equipment or system, or adversely affect living or inert matter

Note 1 to entry: An electromagnetic disturbance may be an electromagnetic noise, an unwanted signal or a change in the propagation medium itself.

Source: 702-08-04

[SOURCE: IEC 60050-101-05]

3.1.13

electromagnetic interference

EMI

degradation of the performance of an equipment, transmission channel or system caused by an electromagnetic disturbance

Note 1 to entry: In French, the terms "perturbation électromagnétique" and "brouillage électromagnétique" designate respectively the cause and the effect, and should not be used indiscriminately.

Note 2 to entry: In English, the terms "electromagnetic disturbance" and "electromagnetic interference" designate respectively the cause and the effect, but they are often used indiscriminately.

Source: 702-08-29

[SOURCE: IEC 60050-101-06]

3.1.14

electrostatic discharge

ESD

transfer of electric charge between bodies of different electrostatic potential in proximity or through direct contact

[SOURCE: IEC 60050-101-22]

3.1.15

enclosure port

physical boundary of the equipment through which electromagnetic fields may be transmitted

3.1.16

equipment directly connected to receiving antennas

equipment of which the input terminal can have a connection to a receiving antenna at least via a cable

Note 1 to entry: That means that the input of the equipment is supplied with the original frequencies as they were received by the antenna.

3.1.17

external immunity

ability of a device, equipment or system to perform without degradation in the presence of electromagnetic disturbances entering other than via its normal input terminals or antennas

[SOURCE: IEC 61000-4-2007]

3.1.18

first satellite intermediate frequency range

output frequency range of the outdoor unit which is comprised of the frequency band between 950 MHz and at least 3,5 GHz or parts thereof

3.1.19

immunity (to a disturbance)

ability of a device, equipment or system to perform without degradation in the presence of an electromagnetic disturbance

[SOURCE: IEC 61000-4-2007]

3.1.20

immunity level

maximum level of a given electromagnetic disturbance incident on a particular device, equipment or system for which it remains capable of operating at a required degree of performance

[SOURCE: IEC 61000-4-2007]

3.1.21

immunity limit

specified minimum immunity level

[SOURCE: IEC 61000-4-2007]

3.1.22

immunity margin

ratio of the immunity limit to the electromagnetic compatibility level

[SOURCE: IEC 61000-4-2007]

3.1.23

in-band immunity

immunity against disturbance at any frequency of the wanted signals carried at the interfaces and used internally within the equipment under test (e.g. input/output frequencies, IF, video band, etc.)

3.1.24

individual receiving system

system designed to provide television and sound signals to an individual household

3.1.25

indoor signal lines

lines which do not leave the building and which are protected by other equipment against outdoor interference (e.g. connections from switching to transmission equipment in the same building)

3.1.26

internal immunity

ability of a device, equipment or system to perform without degradation in the presence of electromagnetic disturbances appearing at its normal input terminals or antennas

[SOURCE: IEC 61000-4-2]

3.1.27

mains immunity

immunity from mains-borne disturbance

[SOURCE: IEC 61000-4-11]

3.1.28

mains powered equipment

active equipment directly connected to the mains via a separate mains line and fed with the mains voltage

3.1.29

multimedia network equipment

equipment containing broadcast and telecommunication functions

3.1.30

operating frequency range

passband for the wanted signals for which the equipment has been designed

3.1.31

outdoor signal lines

lines leaving the building and being subjected to outdoor interference

3.1.32

out-of-band immunity

immunity against disturbance from signals outside the frequency band(s) of the wanted signal carried at the interfaces and used internally within the equipment under test (e.g. input/output frequencies, IF, video band, etc.)

3.1.33

passive equipment

equipment (e.g. splitters, tap-offs, system outlets, etc.) not requiring a power supply in order to operate and/or not carrying out signal processing in a certain frequency range

3.1.34

port

particular interface of the specific equipment with the external electromagnetic environment:

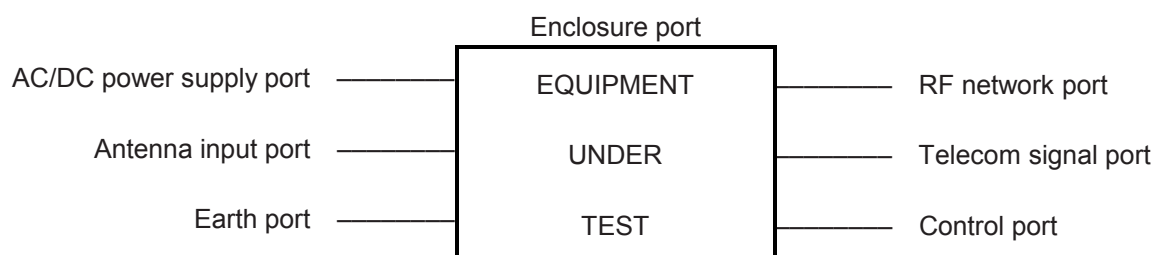

3.1.35

radiation (electromagnetic)

1. phenomenon by which energy in the form of electromagnetic waves emanates from a source into space
2. energy transferred through space in the form of electromagnetic waves

Note 1 to entry: By extension, the term "electromagnetic radiation" sometimes also covers induction phenomena.

Source: 702-02-07

[SOURCE: IEC 161-01-10]

3.1.36

RF network port

point at which a coaxial cable for the wanted RF signal is connected to the equipment but excluding direct connection to the antenna

3.1.37

RF signal port

antenna input port or RF network port

3.1.38

screening effectiveness

ability of an equipment or system to attenuate the influence of electromagnetic fields from outside the equipment or system or to suppress the radiation of electromagnetic fields from inside the equipment or system

3.1.39

signal port

point at which a cable for the wanted signal is connected to the equipment

3.1.40

spurious signals

unwanted signals in the frequency range of interest

3.1.41

telecom network equipment

equipment from which telecom networks are built

Note 1 to entry: Telecommunication network equipment is operated under a licence granted by a national telecommunications authority and provides telecommunications between network termination points (NTPs) (i.e. excluding terminal equipment beyond the NTPs).

3.1.42

telecom signal port

point at which a cable for the wanted telecom signal is connected to the equipment

3.1.43

test levels

preferential range of test level for ESD or fast transient test

3.1.44

transient (adjective and noun)

pertaining to or designating a phenomenon or a quantity which varies between two consecutive steady states during a time interval short compared with the time-scale of interest

Source: 702-07-78

[SOURCE: IEC 161-02-01]

3.1.45

unwanted signal

signals inside and outside of the operating frequency range that are not considered as wanted signal When measuring immunity (to unwanted signals), the unwanted signal shall be simulated using two sine-wave test signals

3.1.46

wanted signal

signal simulated during measurements using a sinewave test signal having the frequency within the operating frequency range and the appropriate level

3.1.47

well-matched

matching condition when the return loss of the equipment complies with the requirements of EN 60728-3:2011, Table 1





3.1.48

well-screened

test set-up with a radiation level, when terminated with a matched load, at least 20 dB below the expected radiation level of the equipment under test, the test set-up and the equipment being supplied with the same input signal level

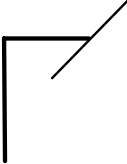
3.2 Symbols

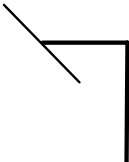
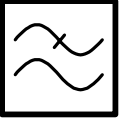
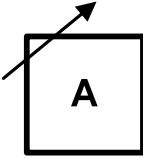
For the purposes of this document, the following graphical symbols are used. These symbols are either listed in IEC 60617 (all parts) or based on symbols defined in IEC 60617 (all parts).

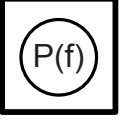
Graphical symbol	Reference number and title	Graphical symbol	Reference number and title
	Equipment under test		Transmitting antenna
	Level meter		Receiving antenna
	IEC 60617 (SO1248) Low pass filter		IEC 60617 (SO1245) Variable attenuator
	IEC 60617 (SO1226) Signal generator		Coupling unit
	IEC 60617 (SO1428) Spectrum analyser		

3.3 Abbreviations

For the purposes of this document, the following abbreviations apply.

AC	alternating current
ALC	automatic level control
AM	amplitude modulation
ATM	Asynchronous Transfer Mode
BSS	broadcast satellite services
CATV	Community Antenna Television (system)
COFDM	Coded Orthogonal Frequency Division Multiplex
CW	continuous wave
DBS	direct broadcast satellite
DOCSIS	Data-Over-Cable Service Interface Specification
EMC	electromagnetic compatibility
emf	electromotive force
EMI	electromagnetic interference
EuroDOCSIS	European technology option of Data-Over-Cable Service Interface Specification (DOCSIS)
EUT	equipment under test
FM	frequency modulation
FSS	fixed satellite services
IF	intermediate frequency
LNB	low noise broadband-converter
MATV	Master Antenna Television (system)
NTP	Network Termination Point
PDH	Plesiochronous Digital Hierarchy
QAM	quadrature amplitude modulation
QPSK	quadrature phase shift keying
RF	radio frequency
SAT	satellite
S-channel	special channel
SDH	Synchronous Digital Hierarchy
SMATV	Satellite Master Antenna Television (system)
TV	television
VHF	very high frequency
VSB	vestigial side band
XDSL	x Digital Subscriber Line ("x" stands for different versions)

NOTE Only the abbreviations used in the English version of the present document are mentioned in this subclause. The German and the French versions of this part may use other abbreviations. Refer to 3.3 of each language version for details.

4 Methods of measurements

4.1 General operating conditions

Measurements shall be, unless otherwise specified, carried out with the rated performance of the equipment under test and at a standard room temperature. If required, additional measurements shall be carried out at the highest and lowest rated ambient temperatures.

The equipment shall be tested including all those sub-assemblies with which it would normally be used.

All operating conditions and configurations that are only temporarily present while adjustment or service is being made shall not be tested.

4.2 Disturbance voltages from equipment

4.2.1 Disturbance voltages from equipment in the frequency range from 150 kHz to 30 MHz

4.2.1.1 Introduction

The method described is applicable to the measurement of disturbance voltages from equipment in the frequency range of 150 kHz to 30 MHz on the mains line.

The measured voltage includes narrowband interference and broadband interference such as that produced by semiconductor rectifiers.

4.2.1.2 General measurement requirements

Disturbance voltage measurements should be carried out in a screened room according to the method described in EN 55013, with the exception that the wanted signal is a sinusoidal carrier. At all frequencies in the range of interest the disturbance voltage injected into the mains by the equipment under test shall be measured by means of a specified artificial mains network with a measuring receiver having a quasi-peak detector for broadband measurements and an average detector for narrowband measurements.

4.2.1.3 Measurement of mains terminal disturbance voltages

4.2.1.3.1 Equipment required

According to EN 55013.

4.2.1.3.2 Equipment layout and connections

According to EN 55013.

4.2.1.3.3 Operating conditions

The equipment under test shall be operated in accordance with the manufacturers' recommendations and tested under conditions that maximise the disturbance voltages.

All RF-ports shall be terminated with non-radiating loads of their nominal impedance. The supply voltage shall be set to values within the specified rating. As a minimum measurements shall be made at the nominal input voltage and at the lower and upper limit of the specified input voltage range.

4.2.1.3.4 Measuring procedure

According to EN 55013.

4.2.1.3.5 Presentation of results

According to EN 55013.

The results shall be expressed in terms of dB(μ V) and shall comply with the limits given in Table 2.

4.2.2 Disturbance voltages from equipment at the AC mains frequency and its harmonics

If the input current rating is within the scope of EN 61000-3-2:2006, the limits and test methods of this standard shall apply.

4.2.3 Measurement of input terminal disturbance voltage

4.2.3.1 General

This measurement is relevant for equipment directly connected to receiving antennas or to satellite outdoor units (e.g. channel converter, DBS tuner etc.).

4.2.3.2 Method of measurement

The measurement shall be performed according to the method described in EN 55013 where "antenna terminal" should be intended as "input terminal" of the equipment under test.

4.2.3.3 Presentation of the results

The disturbance voltage level of the equipment under test at the local oscillator frequency and its harmonics and all other relevant disturbance frequencies shall be expressed in terms of input terminal disturbance voltage in dB(μ V) and shall comply with the relevant limits given in Table 3 and in Table 4.

4.3 Radiation from active equipment

4.3.1 Introduction

The methods described are applicable to the measurement of radiation from active equipment at the signal frequencies, at the local oscillator frequencies and their harmonics and at other relevant frequencies.

In the frequency range 5 MHz to 30 MHz, the "coupling unit" method is used.

In the frequency range 30 MHz to 1 000 MHz ⁴⁾, the "absorbing clamp" method ⁵⁾ of EN 55013 is used.

In the frequency range 950 MHz to 25 GHz, the "substitution" method is used.

For equipment with an upper frequency limit of 1 000 MHz, the absorbing clamp method is used up to 1 000 MHz. For equipment with a lower frequency limit of 950 MHz, only the substitution method is used.

4.3.2 General measurement requirements

4.3.2.1 Measurement conditions

The measurement cables, coupling devices and terminations shall all be well-matched and well-screened. If these conditions cannot be achieved, appropriate corrections shall be made for the results. Test equipment shall be 75 Ω impedance or provided with appropriate matching pads.

An indoor, or outdoor, site may be used. When indoors, a room of sufficient size shall be chosen, so that any reflecting and absorbing objects may be so positioned or sufficiently removed from the measuring set-up that they do not influence the results.

4.3.2.2 Measurement ports

Measurements shall be made at the following ports:

⁴⁾ Due to different channel spacing plans in use, this upper frequency limit may not be exactly 1 000 MHz but some megahertz higher, e.g. 1 006 MHz. The notation 1 000 MHz in this standard is intended to include such small deviations.

⁵⁾ The use of the "absorbing clamp" method provides for consistent and reliable measurements. Measurements based on TEM cell or Triaxial techniques are subject to environmental effects and shall not be used.

- all RF-ports;
- the mains lead (if any);
- all single or multiple wire connections (if any).

4.3.2.3 Measurement frequencies

Measurements shall be made at the following frequencies:

- a) single channel equipment:
 - 1) at the vision and sound carrier frequencies;
 - 2) at any other frequency where disturbance can occur;
- b) wideband equipment:
 - 1) at the highest and lowest vision carrier frequencies in each used band and at a selection of intervening frequencies chosen to give a realistic representation of the radiation pattern throughout the operating frequency range;
 - 2) at any other frequency where disturbance can occur;
- c) frequency converters:
 - 1) output ports and mains lead (if any):
 - i) at the input and output vision and sound carrier frequencies;
 - ii) at all local oscillator fundamental frequencies;
 - iii) at any local oscillator harmonic, and any other frequencies where disturbance can occur;
 - 2) input ports:
 - i) at all local oscillator fundamental frequencies;
 - ii) at selected local oscillator harmonics, or other frequencies (as above).

4.3.3 Methods of measurements

4.3.3.1 Measurement of radiation in the frequency range 5 MHz to 30 MHz

4.3.3.1.1 General

For the measurement of radiation in the frequency range 5 MHz to 30 MHz the coupling unit method shall be used to measure the conducted emissions from the equipment under test.

This method in general is the same as the current injection method described in EN 61000-4-6 with the difference that in this case, no disturbing currents are injected into the connected cables, but the conducted emissions are measured.

The use of an absorbing or injection clamp is also possible in this frequency range. For this purpose, the clamp used shall have similar properties in this frequency range as the 150 Ω coupling units and can be used whenever the coupling units cannot be realised or applied (i.e. due to the number of conductors in one cable or due to the size of the installation). The measurement set-up and the calibration factors shall be given in the manual of the used clamp.

4.3.3.1.2 Equipment required

The following equipment is required:

- one or more signal generators for the wanted signals;
- an RF measuring receiver or spectrum analyser covering the frequency range of interest;
- combiners (for pilot signals);
- appropriate coupling units (according to EN 61000-4-6);
- well-screened terminating loads and cables.

All equipment used for the measurement set-up shall be well screened to avoid inaccurate measuring results. Especially the coaxial coupling units have to be designed for a screening effectiveness greater than 100 dB.

It shall be ascertained that the level of background interfering signals (ingress) is at least 10 dB below the relevant limit, otherwise the result may be significantly affected.

4.3.3.1.3 Equipment layout and connections

The layout of the test equipment is shown in Figure 1. The equipment under test is placed 10 cm above a metallic ground plane of dimension 1 m × 2 m. The coupling units are inserted into the cables. The wanted signal generator is connected to the coupling unit that is connected to the input of the equipment under test. The RF measuring receiver shall be connected to the measuring output of each coupling unit successively. The cables connecting the coupling units to the equipment under test shall be as short as possible.

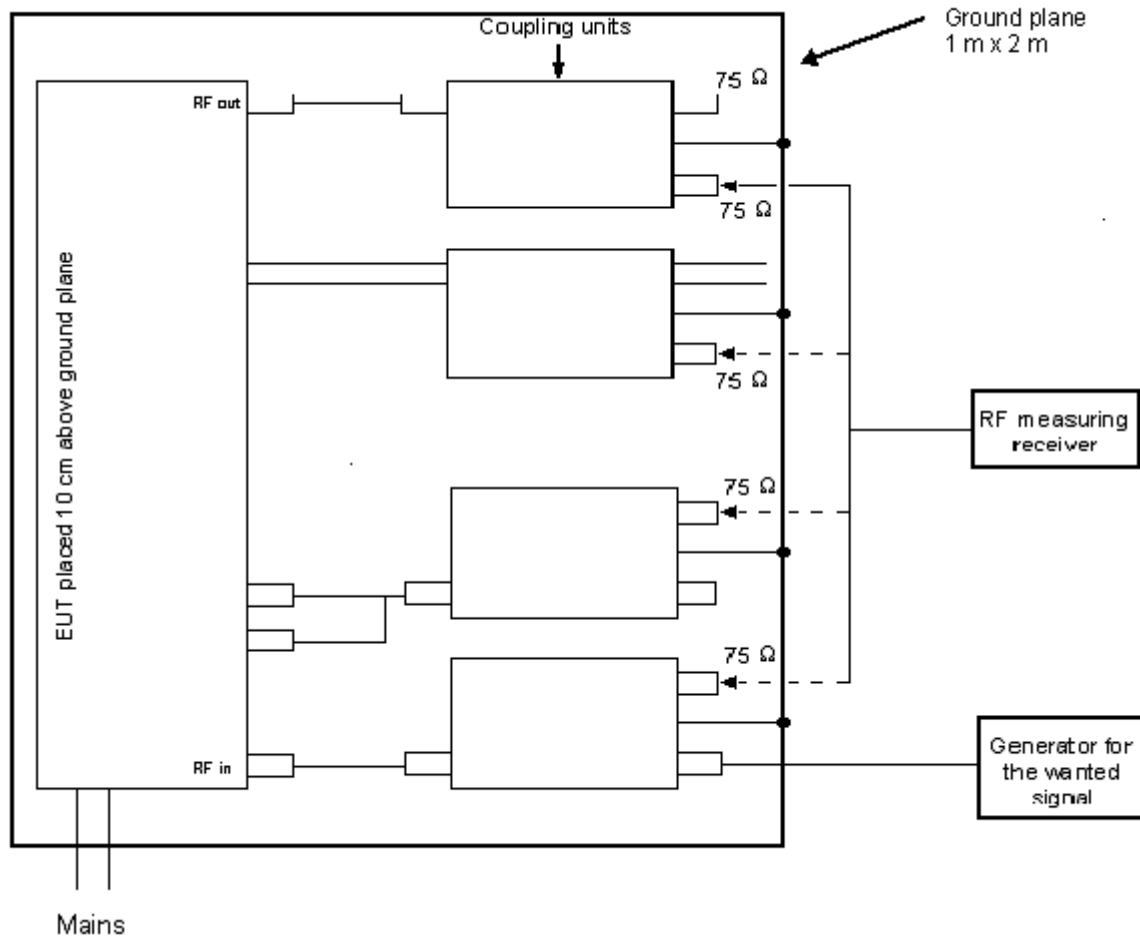

Figure 1 - Measurement set-up for radiation measurements in the frequency range 5 MHz to 30 MHz using the "coupling unit" method

The cables to the input and output of the equipment should be not longer than 30 cm and the mains lead (if any) should be bundled to give a length of 30 cm. The distance between the leads or cables and the ground plane shall be not less than 3 cm.

The mains lead (if any) is not connected to a coupling unit but shall be provided with absorbing devices to avoid the influence of disturbance voltages on the mains lead.

4.3.3.1.4 Operating conditions

The equipment under test shall operate in accordance with the manufacturers' specifications and under conditions that maximise the radiation. The maximum rated output level shall be used for the test and stated on the equipment or accompanying data sheet by the manufacturer.

4.3.3.1.5 Measurement procedure

The generator for the wanted signal is adjusted to the required test frequency and its level is set to the maximum specified operating level at the output of the equipment.

The measuring receiver is successively connected to all coupling units. All unused ports shall be terminated.

For each measuring frequency, the maximum reading is noted.

4.3.3.1.6 Presentation of the results

The readings on the measuring set shall be corrected according to the coupling attenuation of the used coupling units.

For coupling units with $R = 75 \Omega$, the coupling attenuation is 3 dB.

In this case, a measuring receiver of 75Ω impedance shall be used.

NOTE Alternatively coupling units with $R = 100 \Omega$ can be used for measuring receivers with 50Ω input impedance. In this case the coupling attenuation is about 5 dB (4,77 dB).

The radiation level of the equipment under test shall be expressed in terms of power in dB(pW) and shall comply with the limits given in Table 5.

4.3.3.2 Measurement of radiation in the frequency range 30 MHz to 1 000 MHz using the "absorbing clamp" method

4.3.3.2.1 Equipment required

The equipment required for the "absorbing clamp" method is listed below:

- a signal generator covering the frequency range of interest and of sufficient output power;
- an absorbing clamp conforming to EN 55016-1-1;
- a measuring set of appropriate impedance covering the frequency range of interest;
- a measurement cable of length at least $\lambda/2$ (at the lowest frequency of interest) plus 0,6 m and of appropriate impedance;
- screened terminating loads of appropriate impedance and design;
- all necessary coupling devices of an appropriate design;
- a mains filter able to remove extraneous noise from the mains supply in the frequency range of interest;
- absorbing devices such as ferrite rings sufficient to suppress signals from the equipment under test on its input and mains leads;
- a suitable coaxial changeover switch.

4.3.3.2.2 Equipment layout and connections

The measurement set-up and equipment layout for the "absorbing clamp" method (30 MHz to 1 000 MHz) is shown in Figure 2, Figure 3 and Figure 4.

The equipment under test shall be placed at a height of approximately 1 m above the ground on a non-metallic support on which the absorbing clamp can be accommodated and moved.

If no input signal is required (e.g. for measurements of local oscillator radiated power), the input shall be terminated by means of a well-screened load. For measurements of local oscillator power at the input of the outdoor unit, see 4.3.3.4.

The output of the equipment under test shall be connected to a measurement cable of the same characteristic impedance and the cable shall be terminated with the nominal impedance of the output via the coaxial switch.

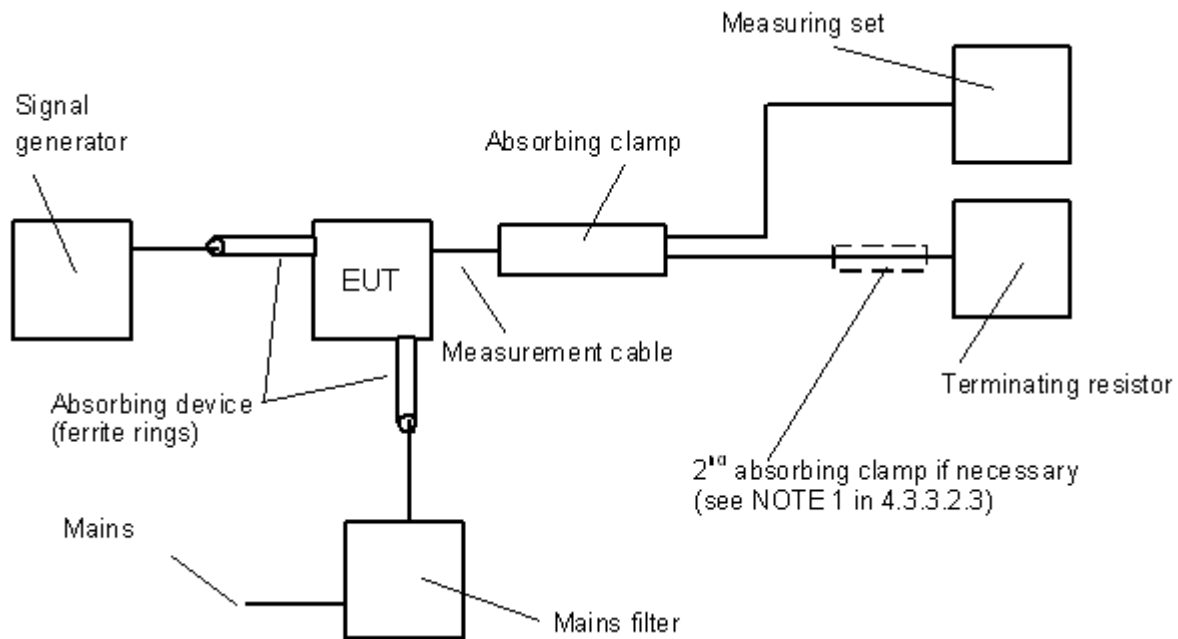

Figure 2 - Absorbing clamp method (30 MHz to 1 000 MHz)

Well-screened cables shall be connected to the terminals of the equipment under test as specified by the manufacturer. When a direct connection cannot be made due to the dimension of the well-screened cable, an adaptor shall be used.

The unused outputs, if any, of the equipment under test shall be terminated with their nominal impedance by means of non-radiating loads directly connected without any cabling.

The mains lead, if any, shall be placed vertically and connected to the mains outlet through a suitable mains filter. Any excess length of the mains lead shall be coiled up neatly at the filter end.

The mains lead and the signal generator coaxial cable shall be provided with suitable absorbing devices (e.g. ferrite rings), placed close to the equipment under test, to avoid measurement errors.

4.3.3.2.3 Operating conditions

The equipment under test shall be operated in accordance with the manufacturer's specifications.

The equipment under test shall be tested under conditions that maximise the radiation. The maximum rated output level shall be used for the test and stated on the equipment or accompanying data sheet by the manufacturer.

The supply voltage shall be set to a value within the specified rating.

Adjustable controls accessible to the user or installer shall be set so as to maximise radiation.

The signal generator at the input shall be adjusted so that the maximum rated output level, within the operating range of the equipment under test, is used.

For sensibly consistent results, the dispositions of the signal generator cable preceding the absorbing device, the mains lead, the measurement cable beyond the absorbing clamp and their proximity to other items shall not influence the readings on the measuring set by more than ± 1 dB. This can be checked by moving the cables and by running the hand along their length after setting up the equipment in accordance with Figure 2 and either Figure 3 or Figure 4.

NOTE 1 At frequencies below about 100 MHz, it may be necessary to add a second absorbing clamp at the far end of the measurement cable as shown in Figure 2. This is to compensate for the reduced absorption of the clamp at these frequencies.

NOTE 2 The absorbing clamp can be calibrated in accordance with the relevant clauses of EN 55016-1-1.

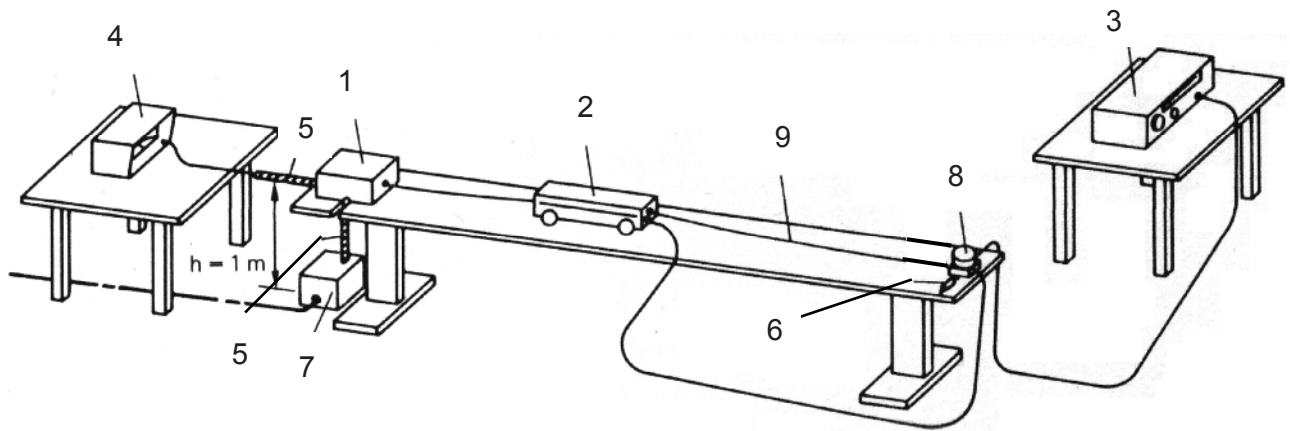

Key

- | | | |
|------------------------|------------------------|--------------------------------|
| 1 equipment under test | 6 terminating resistor | Coaxial switch: Switch-Pos |
| 2 absorbing clamp | 7 mains filter | Measure radiation 3 - 2, 6 - 9 |
| 3 measuring set | 8 coaxial switch | Check level 3 - 9, (6 - 2) |
| 4 signal generator | 9 measurement cable | |
| 5 absorbing device | | |

Figure 3 - Example of general measurement set-up

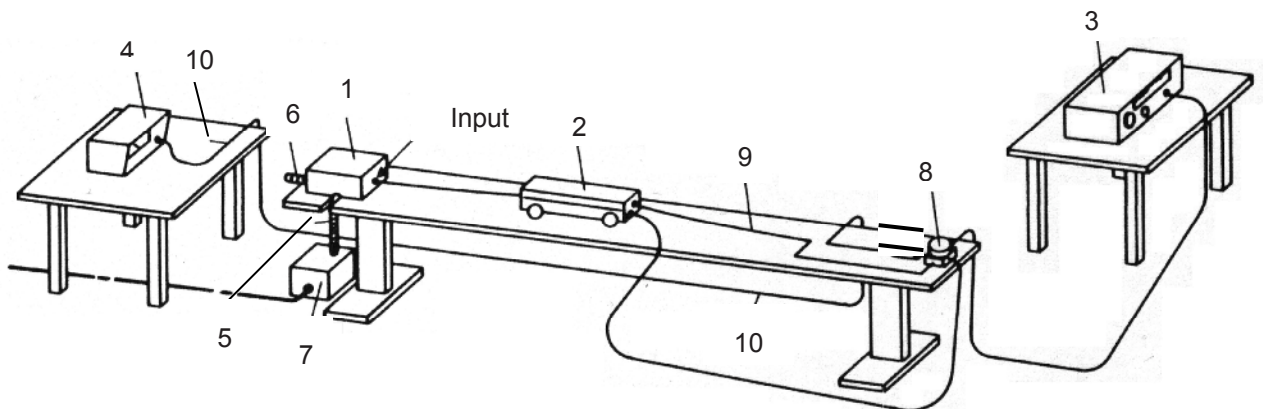

Key

- | | | |
|------------------------|------------------------|---------------------------------|
| 1 equipment under test | 6 terminating resistor | Coaxial switch: Switch-Pos |
| 2 absorbing clamp | 7 mains filter | Measure radiation 3 - 2, 10 - 9 |
| 3 measuring set | 8 coaxial switch | Check level 3 - 10, (9 - 2) |
| 4 signal generator | 9 measurement cable | |
| 5 absorbing device | 10 input signal cable | |

Figure 4 - Example of measurement set-up for measurements on the input port of an active equipment

4.3.3.2.4 Measurement procedure

With the equipment set-up as shown in Figure 2 and Figure 3, and the measurement cable coupled to an output port of the equipment under test, the absorbing clamp is positioned at the equipment end of the

measurement cable and the coaxial switch placed in the "check level" position. Adjust the signal generator to the test frequency and to an input level that will give the maximum rated output level from the equipment under test.

Tune the measuring set. Turn the coaxial switch to the "measure radiation" mode. Move the absorbing clamp along the cable away from the equipment until a maximum reading is obtained on the measuring set (at a spacing of about $\lambda/2$).

This procedure is repeated for each of the test frequencies and for each of the measurement ports.

For radiation measurements on a frequency converter output port, note that the input signal generator shall be set in turn to the input frequencies used and the measuring set tuned to each of the particular output frequencies.

For radiation measurements on the mains lead of active equipment, the equipment shall be connected as shown in Figure 3, except that the mains lead without absorbing devices, extended if necessary, shall pass through the absorbing clamp in place of the measurement cable. Measurements shall be carried out as described above except that the "check-level" position of the coaxial switch is inoperative with this arrangement. Set the signal generator output level to that used when measuring the output port.

4.3.3.2.5 Presentation of results

The readings on the measurement set have to be corrected according to the calibration curve of the absorbing clamp to obtain the radiated power.

The radiation level of the equipment under test shall be expressed in terms of substituted power in dB(pW) and shall comply with the limits given in Table 5.

4.3.3.3 Measurement of radiation in the frequency range 950 MHz to 25 GHz using the "substitution" method

4.3.3.3.1 Equipment required

The equipment required for the "substitution" method is listed below:

- a signal and/or pilot frequency generator covering the frequency range of interest and of sufficient output power;
- suitable receiving antennas covering the frequency range(s) of interest;
- suitable calibrated transmitting antennas covering the frequency range(s) of interest;
- a spectrum analyser of appropriate impedance covering the frequency range of interest;
- high quality connecting coaxial cables of appropriate impedance;
- screened terminating loads of appropriate impedance and design;
- a mains filter able to remove extraneous noise from the mains supply in the frequency range of interest;
- a low-noise preamplifier (if needed).

4.3.3.3.2 Equipment layout and connections

The equipment under test shall be placed on a support of non-metallic material, the height of which shall be 1 m above the ground, as shown in Figure 5.

Equipment that needs an input signal and/or pilot frequencies shall be connected to a suitable signal and/or pilot frequency generator through a well-screened coaxial cable.

If no input signal is required (e.g. for measurements of local oscillator radiated power), the input shall be terminated by means of a well-screened load. For measurements of local oscillator power at the input of the outdoor unit, see 4.3.3.4.

The unused outputs, if any, of the equipment under test shall be terminated with their nominal impedance by means of well-screened loads.

The mains lead, if any, shall be placed vertically and connected to the mains outlet through a suitable mains filter. Any excess length of the mains lead shall be coiled up neatly at the filter end.

The mains lead and the signal generator coaxial cable shall be provided with suitable absorbing devices (e.g. ferrite rings), placed close to the equipment under test, to avoid measurement errors.

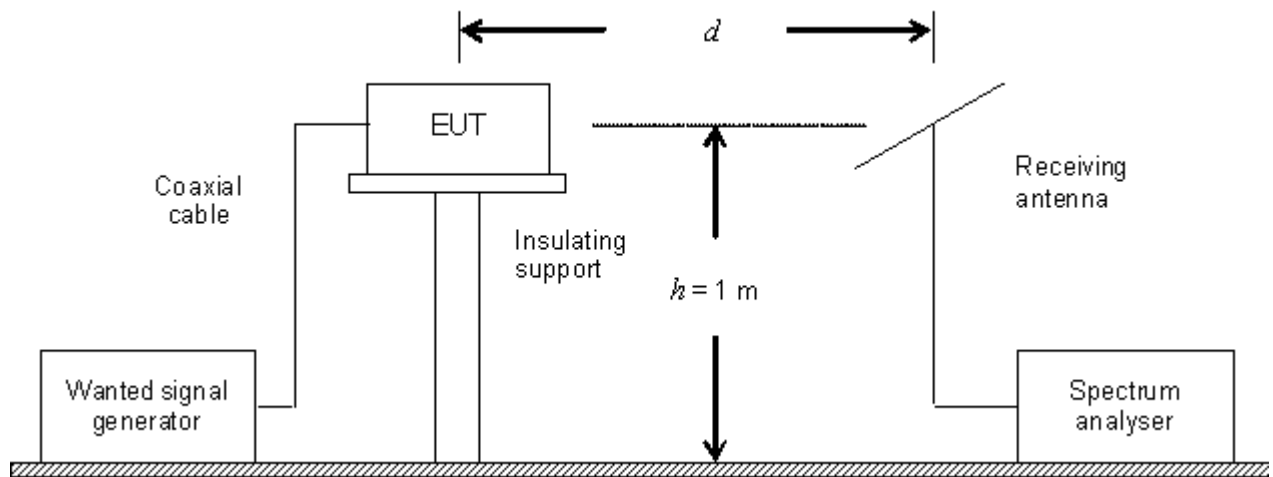

**Figure 5 - Measurement set-up for the "substitution" radiation method –
First measurement step**

4.3.3.3.3 Operating conditions

The equipment under test shall operate in accordance with the manufacturers' specifications and under conditions that maximise the radiation. The maximum rated output level shall be used for the test and stated on the equipment or accompanying data sheet by the manufacturer.

The measurements shall be made with a directional antenna of small aperture capable of making separate measurements of the vertical and horizontal polarisation of the radiated field. The height above the ground of the centre line of the antenna shall be the same as the height of the approximate radiation centre of the equipment under test.

In order to avoid the influence of the ground reflection on the results, it is recommended to use a suitable horn antenna. In that case, no metallic ground plane is needed. To fulfil the "Fraunhofer conditions", the measuring distance shall be:

$$d > 2 b^2/\lambda$$

where

b is the wider dimension of the horn mouth;

λ is the wavelength corresponding to the test frequency.

The measuring set used in this frequency range usually consists of a spectrum analyser. If the radiation level is low, a low-noise preamplifier may be needed.

4.3.3.3.4 Test site validation

The validation of the test site shall be determined as follows. A transmitting antenna shall be mounted at the position where it is intended that the approximate radiation centre (usually the volume centre) of the equipment under test is to be placed. The receiving antenna shall be placed at the same position as that chosen for the actual measurements. The two antennas shall be placed so that they have the same polarisation, which shall be perpendicular to an imaginary line between them. Tests shall be made in the horizontal and vertical polarisation planes.

The test site shall be considered suitable for the purpose of measurement at a test frequency if the indication on the measuring set changes by no more than 1,5 dB when the centre of the transmitting antenna is moved from 0 cm to 20 cm in any direction from its initial position.

NOTE The gain of the applied transmitting antenna in dB above the half-wave dipole shall be taken into account.

4.3.3.3.5 Measurement procedure

Measurements shall be made by the substitution method with the antenna having both horizontal and vertical polarisations and the turntable with the equipment under test shall be rotated. The equipment shall be rotated in all planes. The highest level of radiation measured shall be noted at each measuring frequency.

Then the equipment under test is replaced by a calibrated transmitting antenna supplied by a standard generator. Its centre shall be placed in the same initial position of the equipment centre according to Figure 6.

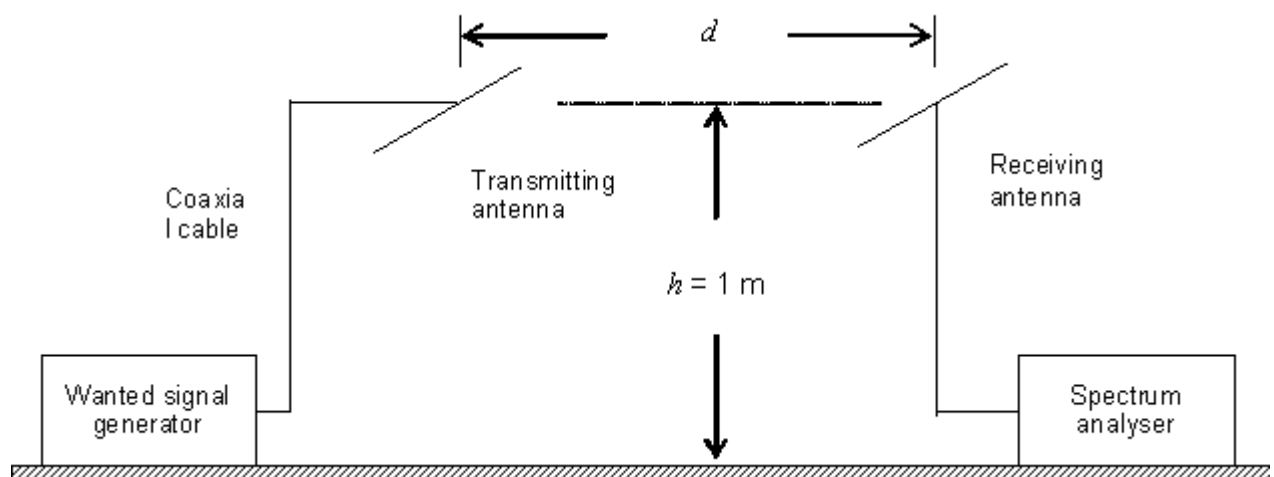

Figure 6 - Measurement set-up for the "substitution" radiation method – Second measurement step

For each measuring frequency, the output level of the generator is adjusted in order to give the same reference indication on the spectrum analyser as achieved with the EUT. The level of the available power of the generator, increased by the radiating antenna gain above the half-wave dipole, is taken as the level of the radiated power of the equipment under test at the considered frequency.

NOTE The equivalent radiated power is given by the following formula:

$$P = P_g - A_c + G_a$$

where

P	is the equivalent radiated power in dB(pW);
P_g	is the available power of the generator in dB(pW);
A_c	is the loss of any cables and adaptors between generator and antenna in dB;
G_a	is the gain of the transmitting antenna in dB referred to the half-wave dipole antenna.

It shall be ascertained that, when the equipment under test is switched off, the level of background noise is at least 10 dB below the relevant limit, otherwise the reading may be significantly affected.

4.3.3.3.6 Presentation of the results

The radiation level of the equipment under test shall be expressed in terms of substituted power in dB(pW) and shall comply with the relevant limits given in Table 5.

4.3.3.4 Measurement of local oscillator power at the outdoor unit input

4.3.3.4.1 Method of measurement

The power at the outdoor unit input (inclusive of e.g. polariser, orthomode transducer, bandpass filter, RF waveguide, etc.) shall be measured according to the measurement method described in 4.3.3.3, with the exception that the equipment does not need any input signals from a signal generator.

If a suitable interface at the input of the outdoor unit (e.g. R120, C120) is available, the local oscillator power can be measured by a power meter combined with a corresponding adapter.

4.3.3.4.2 Presentation of the results

The power level of the equipment under test shall be expressed in terms of substituted power in dB(pW) and shall comply with the relevant limits given in Table 6.

4.4 Immunity of active equipment

4.4.1 Introduction

Any RF signal entering the equipment may produce interference. Unwanted signals can appear at the output of the equipment when disturbance frequencies are entering because of poor immunity:

- generate intermodulation products with the wanted signal and other signals being distributed or transfer their modulation through crossmodulation to the wanted signal,
- beat with oscillator signals or their harmonics or with other signals being distributed,
- fall in the nominal frequency ranges of the equipment.

Due to the assignment of the frequency range 790 MHz to 862 MHz to broadband wireless services a changed EMC environment in this frequency band has to be taken into account for active and passive cable network equipment. When wireless base stations and user equipment are communicating, the resulting radio signals may cause in-band disturbances due to higher field strength levels than previously encountered by cable network equipment.

As a result of this changed situation additional requirements on immunity of active equipment are specified.

4.4.2 Performance criterion

Performance criterion A (according to EN 61000-6-1:2007) shall be applied:

The equipment shall operate as intended during the test. No degradation of performance or loss of function is allowed below a performance level specified by the manufacturer, when the equipment is used as intended.

The performance level may be replaced by a permissible loss of performance. No change of actual operating state or stored data is allowed.”

For the scope of this standard, the immunity level shall correspond to the level of the incident electromagnetic disturbance, which produces a just perceptible interference at the output of the equipment under test, when a specified operating level is present at the input or output of the equipment under test.

It is assumed that the just perceptible interference corresponds to an in-channel RF wanted-to-unwanted signal ratio of:

- 60 dB for AM-VSB-TV and FM radio,
- 35 dB for FM-TV and DVB-S/QPSK,
- 35 dB for digitally modulated TV and data signals (DVB-C/QAM, DVB-T/COFDM)

when measured at the output of the equipment under test.

NOTE 1 The value for digitally modulated TV and data signals (terrestrial and cable transmissions) is derived from the minimum requirement of 32 dB for the RF signal-to-noise ratio $S_{D,RF}/N$ of 256 QAM modulated signals at the system outlet (EN 60728-1:2008, Table 11) with a surplus of 3 dB. It covers also the requirements of 64 QAM and COFDM signals taking into account that those signals partly use lower minimum signal levels.

NOTE 2 For compliance testing, it is not necessary to measure the actual level of immunity, but only to ensure that the immunity requirements of Clause 5 are complied with.

4.4.3 Measurement of the external immunity to ambient fields

4.4.3.1 Out-of-band immunity (modulated interfering signal)

4.4.3.1.1 General

Out-of-band immunity test is only relevant to active equipment where in-band immunity is not required.

For the disturbance frequency range 150 kHz to 80 MHz, measurements shall be made with the injection method described in EN 61000-4-6.

For the disturbance frequency range 80 MHz to 3,5 GHz, measurements shall be made on a test site using the radiated field method described in EN 61000-4-3 (extended to 3,5 GHz, using suitable antennas).

For the frequency range 3,5 GHz to 25 GHz, methods of measurement are investigated for inclusion in a future amendment or revised edition.

4.4.3.1.2 Test frequencies

For single channel equipment, measurements shall be carried out using a disturbance field at frequencies outside the nominal frequency ranges of the equipment under test (Figure 7 and Figure 8). For converters the disturbance field shall be at frequencies outside both the input and output nominal frequency ranges.

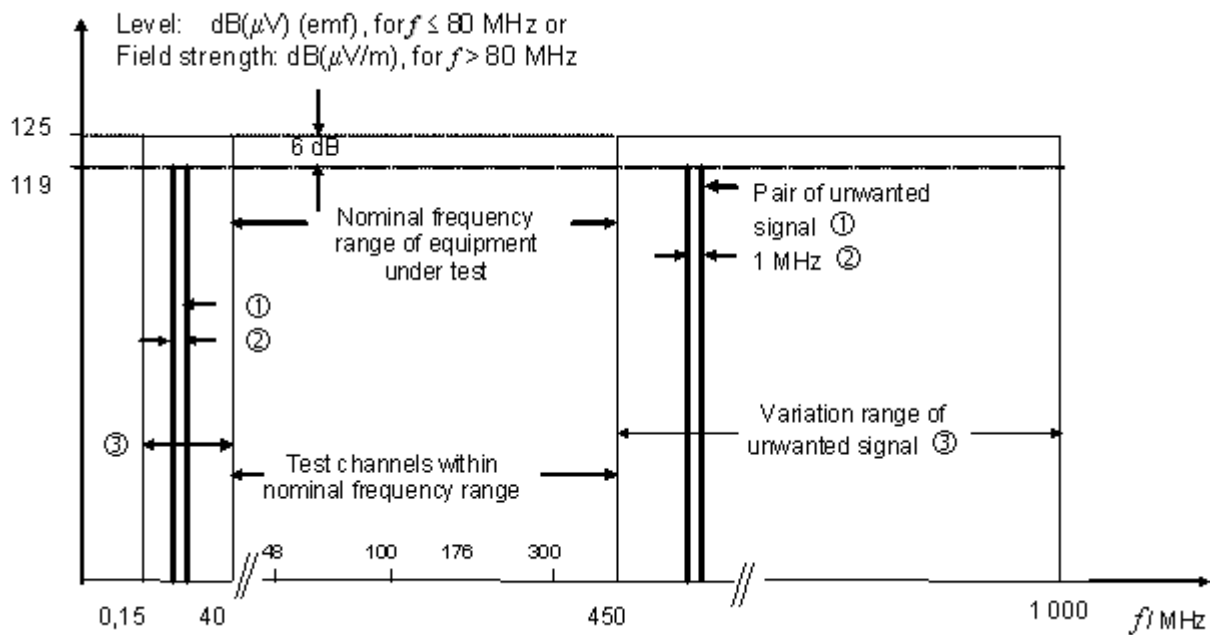

NOTE EXAMPLE VHF broadband amplifier; bandwidth 40 MHz to 450 MHz.

Figure 7 - Frequency allocation for out-of-band immunity measurement of active equipment with nominal upper frequency limit $\leq 1\,000$ MHz

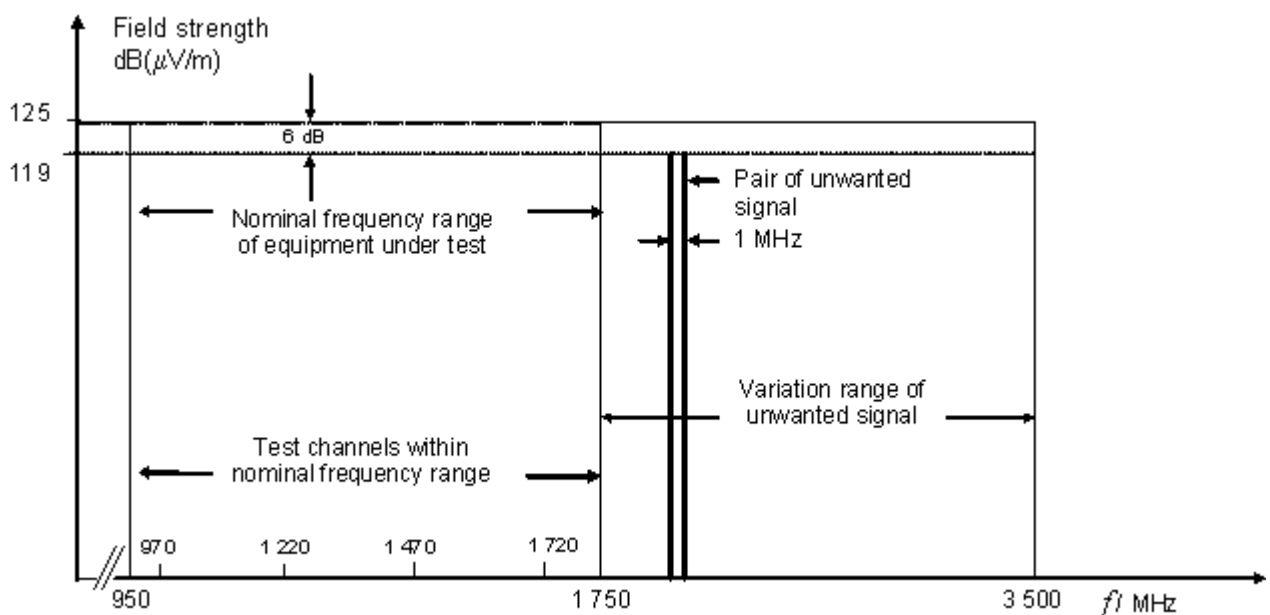

NOTE EXAMPLE IF amplifier; bandwidth 950 MHz to 1 750 MHz.

Figure 8 - Frequency allocation for out-of-band immunity measurement of active equipment with nominal lower frequency limit ≥ 950 MHz

For broadband equipment, measurements shall be carried out using a disturbance field at frequencies outside the nominal frequency ranges of the equipment under test (Figure 7 and Figure 8). The wanted channels to be tested shall be taken at least at the following centre frequencies that fall within the nominal frequency ranges of the equipment under test.

For equipment that does not have a nominal frequency range (e.g. power supplies, control units), measurements shall be carried out in the whole specified disturbance frequency range.

4.4.3.1.3 Equipment with nominal upper frequency limit $\leq 1\ 000$ MHz

Test channels with bandwidth 8 MHz
at centre frequencies: 48 MHz, 100 MHz, 176 MHz, 480 MHz, 680 MHz, 850 MHz

4.4.3.1.4 Equipment with nominal lower frequency limit ≥ 950 MHz

Test channels with bandwidth 27 MHz
at centre frequencies: 970 MHz, 1 220 MHz, 1 470 MHz, 1 720 MHz, 1 970 MHz, 2 220 MHz,
2 470 MHz, 2 720 MHz, 2 970 MHz, 3 220 MHz, 3 470 MHz

4.4.3.1.5 Test conditions

In all cases, the measurement of the out-of-band immunity of equipment involves an evaluation of the effects of the disturbance field on the normal output signal.

The equipment under test shall be operated at its nominal power supply voltage and under typical conditions, whether manual or automatic.

All unused inputs and outputs shall be correctly terminated using screened termination loads. Any manual controls shall be adjusted to give maximum gain and the correct amplitude/frequency response.

The wanted signal generator shall be set to the wanted channel frequency f_v .

The output level of the wanted signal generator is adjusted to give the specified maximum level at the output of the equipment under test.

The disturbing field is simulated by two discrete carriers (two unwanted signals), the field strength levels of which are 6 dB down from the reference level in Table 7 and spaced 1 MHz away from each other. The reference frequency for the two unwanted signals shall be the arithmetical mean value of their individual frequencies.

4.4.3.1.6 Out-of-band immunity

For the scope of this standard, the external immunity level will correspond to the level of the incident electromagnetic disturbance outside the nominal frequency ranges, which produces a just perceptible interference (see NOTE 2 to 4.4.2) at the output of the equipment under test, when the maximum output level, as defined and published by the manufacturer, is present at the output.

4.4.3.1.7 Measurement procedure

The wanted signal generator shall be adjusted to give the test conditions above, the signal level at the output of the equipment under test being measured using the measuring receiver or spectrum analyser.

The measuring receiver or spectrum analyser shall then be tuned to the two amplitude interference products (f_v-1 MHz and f_v+1 MHz) within the wanted channel and the output levels of the unwanted signal generators are adjusted simultaneously to obtain, at the output of the equipment under test, an RF carrier-to-interference signal ratio which complies with the performance criterion given in 4.4.2.

The equipment under test shall be rotated in all planes and the minimum output level of the unwanted signal generator shall be noted at each measuring frequency.

Harmonics of the disturbing signals shall not be taken into account.

In the case of equipment provided with automatic level control, care shall be taken to keep the wanted signal level and pilot levels constant.

4.4.3.1.8 Presentation of the results

The results are expressed in terms of the lowest voltage level in dB(μ V) (emf) up to 80 MHz or in terms of the lowest field strength level in dB(μ V/m) above 80 MHz for the performance criterion given in 4.4.2, and shall comply with the relevant limit given in Table 7.

4.4.3.2 In-band immunity (unmodulated interfering signal)

4.4.3.2.1 General

For the disturbance frequency range 150 kHz to 80 MHz, measurements shall be made with the injection method described in EN 61000-4-6, but with the disturbing frequencies in accordance with in-band definition.

For the disturbance frequency range 80 MHz to 3,5 GHz, measurements shall be made on a test site using the radiated field method described in EN 61000-4-3 (extended to 3,5 GHz, using suitable antennas).

For the frequency range 3,5 GHz to 25 GHz, methods of measurement are investigated for inclusion in a future amendment or revised edition.

4.4.3.2.2 Equipment required

The test equipment required for the measurement of the in-band immunity of equipment is listed below:

- a signal generator covering the frequency range of interest and representing the respective wanted signal, as well as pilot-signal generators, as required;
- a power RF generator covering the frequency range of interest and of sufficient output power to feed the transmitting antenna and/or stripline (unwanted signal);
- a measuring receiver or spectrum analyser;
- suitable combiners, test cables and terminating loads all of which shall be well-matched and well-screened.

NOTE Test equipment for connection to the unit under test should be of 75 Ω impedance or provided with appropriate matching pads.

4.4.3.2.3 Test frequencies

Measurements shall be carried out using a CW disturbance field, the frequency of which is placed 2 MHz \pm 0,5 MHz from the wanted signal (Figure 9 and Figure 10). The test frequencies shall be selected to obtain a realistic presentation of the in-band immunity over the nominal frequency range. The wanted signal frequency and the disturbance frequencies shall be selected to fall within the wanted channel in the case of channel-selective equipment.

In the case of broadband equipment, the following centre frequencies that fall within the band of the equipment under test shall be used. The unwanted signal shall be placed 2 MHz \pm 0,5 MHz apart from the wanted signal.

4.4.3.2.4 Equipment with nominal upper frequency limit \leq 1 000 MHz

Wanted signal frequencies: 27 MHz, 48 MHz, 144 MHz, 176 MHz, 300 MHz, 470 MHz, 680 MHz, 860 MHz, 960 MHz

4.4.3.2.5 Equipment with nominal lower frequency limit \geq 950 MHz

Wanted signal frequencies: 970 MHz, 1 220 MHz, 1 470 MHz, 1 720 MHz, 1 970 MHz, 2 220 MHz, 2 470 MHz, 2 720 MHz, 2 970 MHz, 3 220 MHz, 3 470 MHz

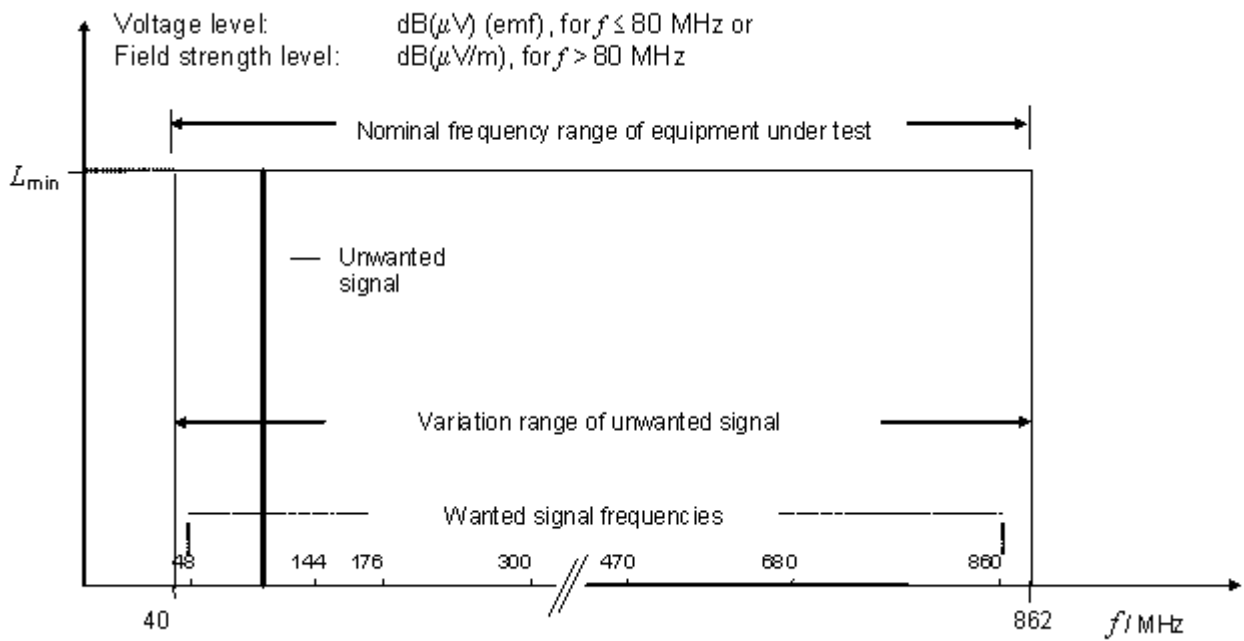

L_{min} Minimum immunity level as defined in 5.4.1.2

NOTE EXAMPLE Broadband amplifier; bandwidth 40 MHz to 862 MHz.

Figure 9 - Frequency allocation for in-band immunity measurement of active equipment with nominal upper frequency limit $\leq 1\ 000$ MHz

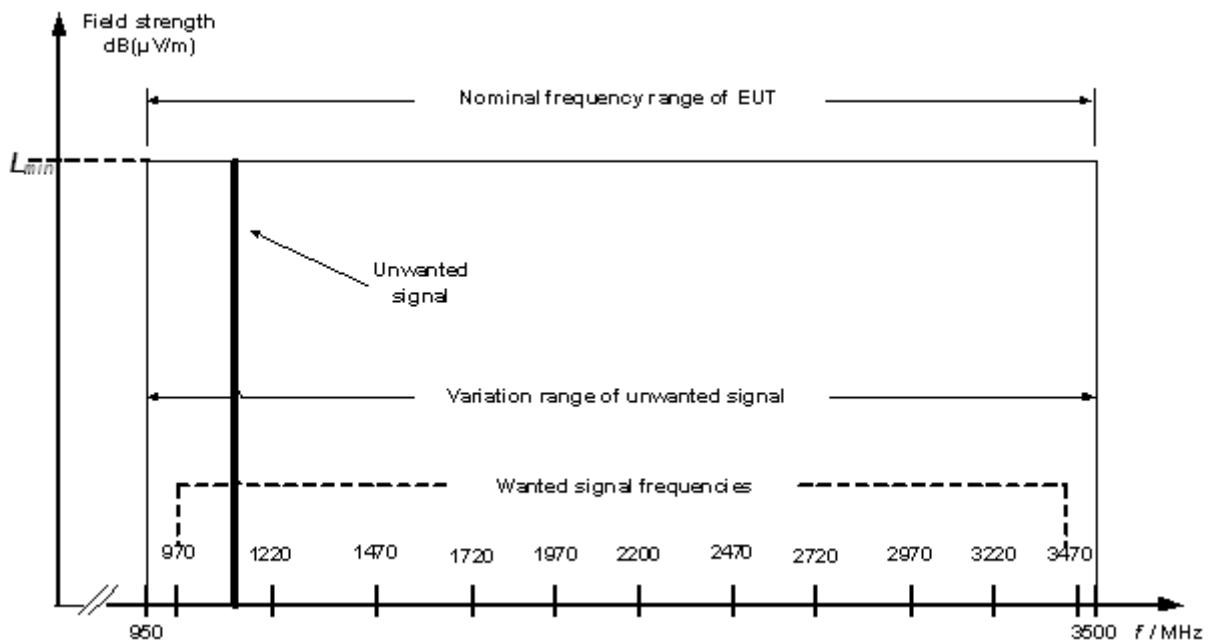

L_{min} Minimum immunity level as defined in 5.4.1.2

NOTE EXAMPLE IF amplifier; bandwidth 950 MHz to 3 500 MHz.

Figure 10 - Frequency allocation for in-band immunity measurement of active equipment with nominal lower frequency limit ≥ 950 MHz

4.4.3.2.6 Test conditions

In all cases, the measurement of the in-band immunity of equipment involves an evaluation of the effects of the disturbance field on the normal output signal.

The equipment under test shall be operated at its nominal power supply voltage and under typical conditions, whether manual or automatic.

All unused inputs and outputs shall be correctly terminated using screened terminating loads. Any manual controls shall be adjusted to give maximum gain and the correct amplitude/frequency response.

A wanted signal with the lowest specified input level shall be applied to the input. If no input level is specified by the manufacturer the wanted signal shall be applied with a level of 70 dB(μ V) and with a level of 59 dB(μ V) for digitally modulated signals in the frequency range 790 – 862 MHz.

NOTE The level of 70 dB(μ V) is an average value between the minimum and maximum signal levels for analogue modulation at the system outlet according to EN 60728-1. The level of 59 dB(μ V) is an average value between the minimum and maximum signal levels for digital modulation at the system outlet according to EN 60728-1.

4.4.3.2.7 In-band immunity

For the scope of this standard, the in-band immunity will correspond to the level of the incident electromagnetic disturbance within the nominal frequency ranges, which produces a just perceptible interference (see performance criterion given in 4.4.2) under the above-mentioned testing conditions at the output of the equipment under test.

4.4.3.2.8 Measurement procedure

The wanted signal generator shall be adjusted to give the test conditions specified above, the signal levels at the output of the equipment under test being measured using the measuring receiver or the spectrum analyser. The frequency of the unwanted signal shall then be varied over the nominal frequency ranges and its level is adjusted to obtain, at the output of the equipment under test, an RF carrier-to-interference signal ratio that complies with the performance criterion given in 4.4.2.

The measurements shall be carried out at the test frequencies above listed. The highest interference is expected when the frequency of the unwanted signal lies within the test channel, but also all other interference signals, which may occur due to conversion or intermodulation with the participation of the unwanted signal within the nominal frequency ranges, shall be evaluated.

The equipment under test shall be rotated in all planes and the minimum output level of the unwanted signal generator shall be noted at each measuring frequency.

Harmonics of the disturbing signal shall not be taken into account.

In the case of equipment provided with automatic level control, care shall be taken to keep the wanted signal level and pilot levels constant.

4.4.3.2.9 Presentation of the results

The results shall be expressed in terms of the lowest voltage level in dB(μ V) (emf) up to 80 MHz or in terms of the lowest field strength level in dB(μ V/m) above 80 MHz for the performance criterion given in 4.4.2 and shall comply with the relevant limit given in Table 8.

4.4.4 Internal immunity (Immunity to unwanted signals)

4.4.4.1 General

4.4.4.1.1 Introduction

The measurement methods specified below serve to determine the immunity of an active equipment processing analogue modulated signals to disturbance by unwanted signals occurring both outside of its operating frequency range (out-of-band disturbance) and within of its operating frequency range (in-band disturbance). Therefore, internal immunity measurements shall not be performed on channel-selective equipment processing exclusively DVB signals (e.g. DVB tuners or headend equipment).

Wireless services operating in the frequency band 790 MHz to 862 MHz may be received by broadcast receiving antennas and be fed into the input of a broadband amplifier with an operating frequency range up to 862 MHz. This will cause in-band interference between the received broadcast signals (wanted signals) and the wireless signals (unwanted signals).

NOTE If the frequency range 790 MHz to 862 MHz carries no wanted signals, a low-pass filter could be applied at the input of the broadband amplifier to sufficiently reduce in-band interference, e.g. overload of the amplifier, caused by the high-level wireless signals.

4.4.4.1.2 Method of measurement

If the equipment under test are frequency converters that serve to convert one or more RF input frequency ranges to one or more RF output frequency ranges, the measurements shall account for possible combination products of wanted signals, unwanted signals and the local oscillator frequency.

4.4.4.1.3 Internal immunity level

For the scope of this standard, the internal immunity level is the maximum level of the unwanted signal applied to the input terminals that comply with the performance criterion given in 4.4.2.

4.4.4.1.4 Test set-up

The test set-up is shown in Figure 11. The test equipment and auxiliary items shall be properly interconnected with their characteristic impedances and be well-matched over the operating frequency range.

Prior to measurements, the test set-up shall be checked to ensure that it is sufficiently free of internally generated distortion products. Mutual modulation of test signal sources can be avoided by increasing the attenuation between signal generators.

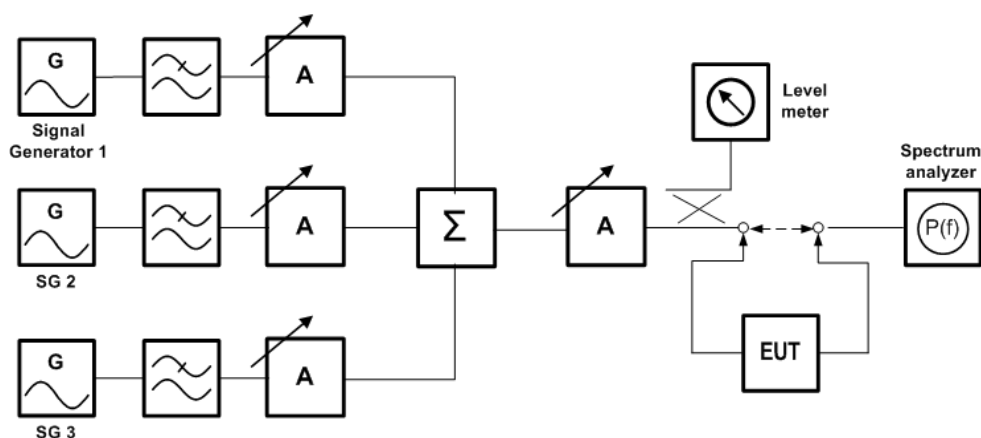

Figure 11 - Measurement set-up for internal immunity test

4.4.4.1.5 Measurement procedure

The measurement shall be carried out based on the three-signal measurement method, where the unwanted signal is simulated by two discrete carriers that are 6 dB down from the reference level and spaced of a specified amount away from each other.

The equipment under test shall be subjected to disturbance by unwanted signals in accordance with the relevant limit curves.

4.4.4.1.6 Test condition

The limit curves specify the minimum levels of unwanted signals at which the equipment shall meet the performance requirement.

The limit curve to be applied shall be appropriately selected for the operating frequency range of the equipment under test and be adapted to the limits of the operating frequency range, if required.

At the output of the equipment under test, all RF carrier-to-interference signal ratios are measured by means of a measuring receiver or spectrum analyser and the worst value is noted.

4.4.4.1.7 Internal immunity to out-of-band disturbing signals

The level of the wanted signal shall be adjusted according to the specifications given in 4.4.4.2 for the frequency range 47 MHz to 862 MHz and in 4.4.4.3 for the frequency range 10,70 GHz to 12,75 GHz.

For measurements of immunity to out-of-band disturbing signals, the unwanted out-of-band signals shall be applied to the input of the equipment under test in accordance with the relevant limit curve.

It is permitted to introduce a system-specific level reduction of 3 dB when making measurements on a converter designed for circular polarisation, but exposed to disturbance by unwanted signals with linear polarisation.

At the output of the equipment under test measurements shall be made in order to determine if all intermodulation products generated by wanted and unwanted signals or by unwanted signals alone, or involving the oscillator frequency (if applicable), shall comply with performance criteria (see 4.4.2).

During measurements, the wanted signal shall be tuned over the operating frequency range. The worst result shall be noted in each case.

If different input frequency ranges (e.g. different planes of polarisation) are combined by a equipment to form a single output frequency range any unwanted signals that fall within the operating output frequency range after conversion shall be considered as intermodulation products.

4.4.4.1.8 Internal immunity to in-band disturbing signals

The level of the wanted signal shall be adjusted according to the specification given in 4.4.4.3. For measurements of immunity to in-band disturbing signals, the simulated unwanted signal shall be applied to the input of the equipment under test in accordance with the relevant limit curve.

It is permitted to introduce a system-specific level reduction of 3 dB when making measurements on a converter designed for circular polarisation, but exposed to disturbance by unwanted signals with linear polarisation.

At the output of the equipment under test, measurements shall be made in order to determine if all intermodulation products generated by the wanted and unwanted signals and falling within the operating frequency range shall comply with the performance criterion given in 4.4.2.

If different input frequency ranges are combined to form a single output frequency range, unwanted signals that fall outside of their original input frequency range shall be considered as distortion products.

4.4.4.2 Internal immunity in the frequency range 47 MHz to 862 MHz

4.4.4.2.1 General

For active equipment directly connected to receiving antennas, the output level of all intermodulation products that fall within the frequency passband of the equipment under test shall be such that the carrier-to-interference ratio shall comply with performance criterion given in 4.4.2.

4.4.4.2.2 Method of measurement

Measurements shall be performed with the set-up of Figure 11 using one wanted signal in one of the television or radio broadcast bands and one unwanted modulated signal represented by two unmodulated carriers. The level of the wanted signal shall be adjusted to the specified maximum operating level (according to EN 60728-3). The levels of the two unmodulated carriers (representing the unwanted signal) shall be 6 dB down from that specified in Table 9 and shall be spaced 1 MHz one from the other.

NOTE This requirement should not apply to channel-selective equipment designed for the frequency range 87,5 MHz to 108 MHz.

With sub-band, full-band and multi-band amplifiers, frequency converters or similar equipment the level of the wanted signal shall be increased by 3 dB.

Selective circuits (channel filters, bandpass filters and similar) that are necessary to meet the requirements regarding immunity to unwanted signals shall be integral parts of active equipment, that is, the equipment shall not be operative without these circuits.

4.4.4.2.3 Presentation of the results

The results are expressed in terms of carrier-to-interference ratio in dB and shall comply with the performance criterion given in 4.4.2, with the appropriated test specification of Table 9.

4.4.4.3 Internal immunity in the frequency range 10,70 GHz to 12,75 GHz

4.4.4.3.1 Limits of application

The measurement of internal immunity for outdoor-units in the frequency range 10,70 GHz to 12,75 GHz has to be seen as recommendation to assure the proper operation of satellite receiving outdoor units at least in CATV and MATV headend applications. If applied to outdoor units, measurements shall be performed with the set-up of Figure 11 using one unmodulated wanted signal and one unwanted modulated signal represented by two unmodulated carriers. The level of the wanted signal shall be adjusted as given in Figure 12 and Figure 13. The levels of the two unmodulated carriers (representing the unwanted signal) shall be 6 dB down from that specified in Table 9 and shall be spaced 1 MHz one from the other.

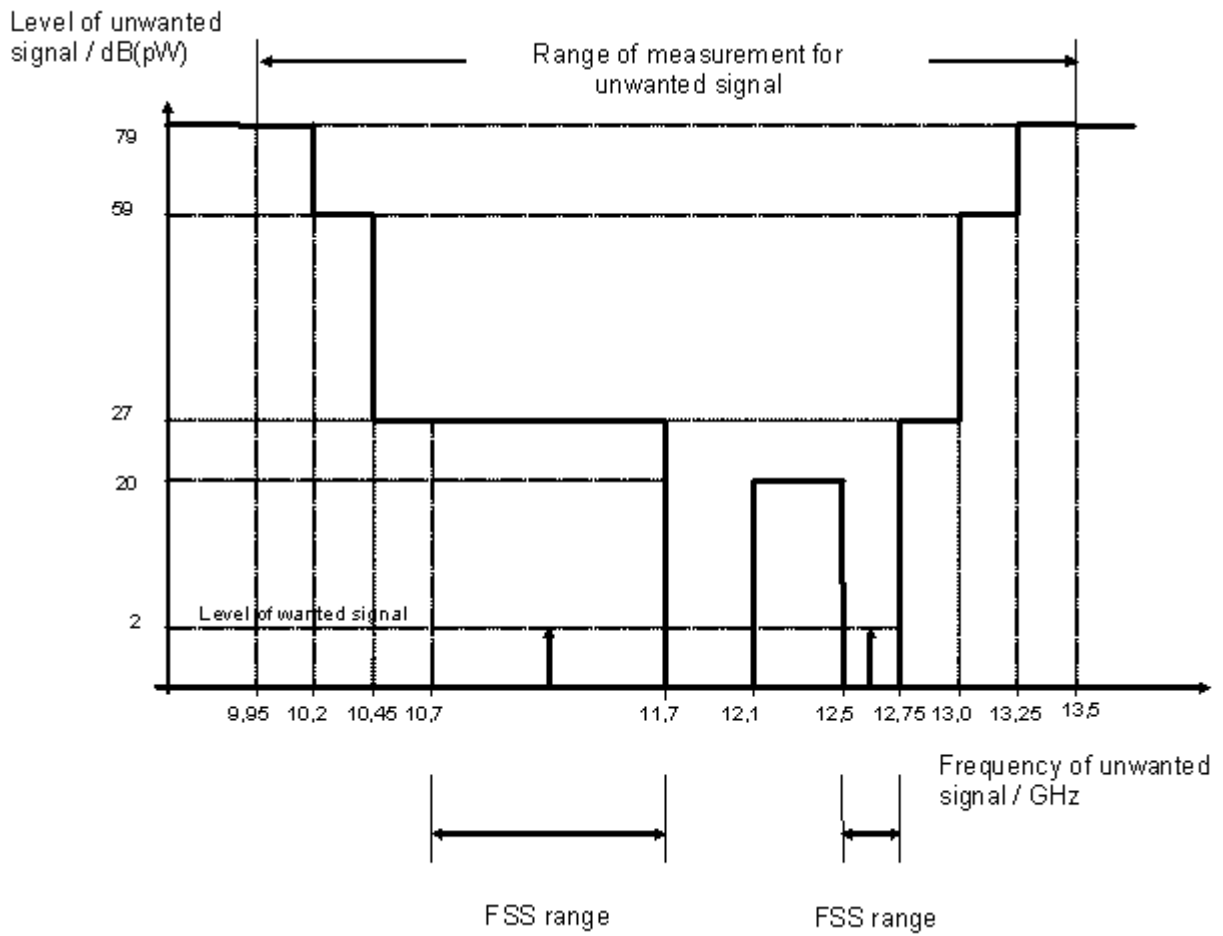

Figure 12 - Levels of wanted and unwanted signals for the internal immunity of FSS receiving outdoor units

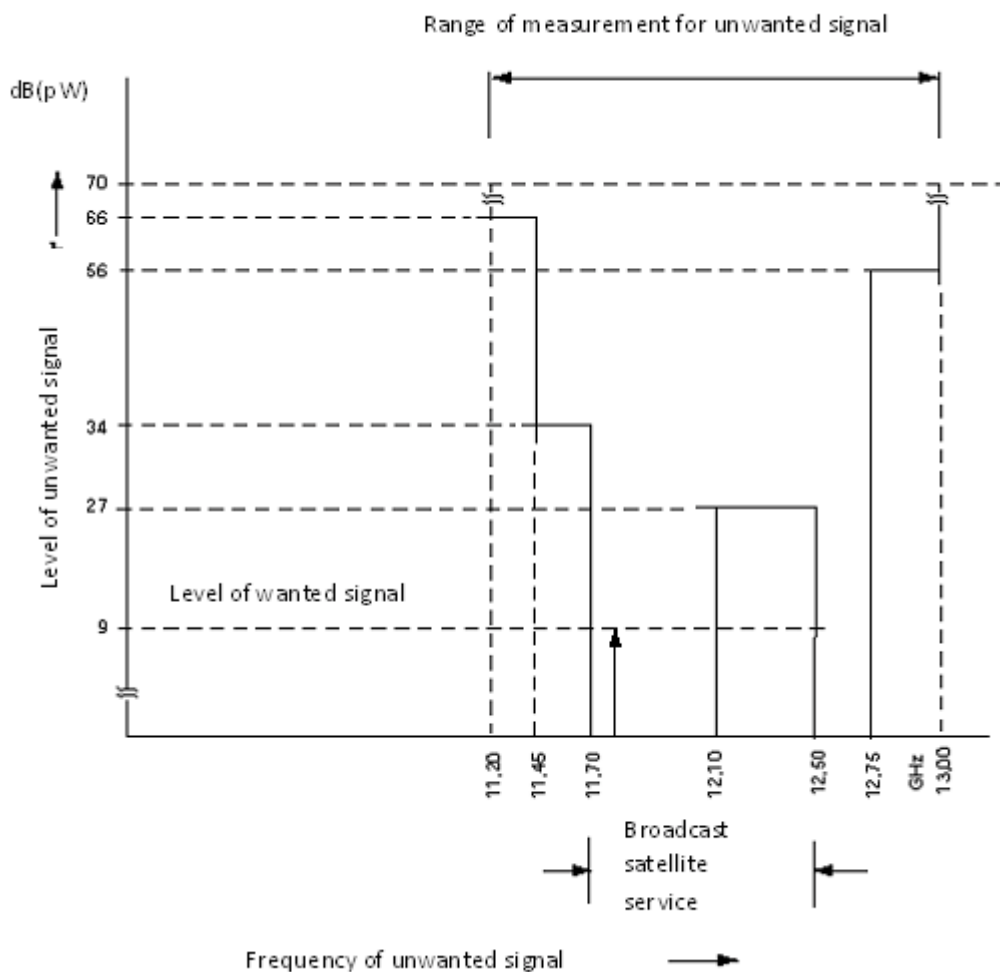

Figure 13 - Levels of wanted and unwanted signals for the internal immunity of BSS receiving outdoor units

4.4.4.3.2 Single outdoor unit

All intermodulation products at the output of the outdoor unit, falling within the output SAT-IF-frequency range, shall give a carrier-to-interference ratio that complies with the performance criterion given in 4.4.2.

This is based on the assumption that at least one wanted signal and one unwanted signal, in accordance with the limit curves given in Figure 12 and Figure 13, are involved.

4.4.4.3.3 Multiple outdoor units

When using multiple outdoor units with a combined output, the distortion products caused by unwanted signals and/or wanted signals, falling within the frequency ranges produced by the multiple outdoor units, shall be at least 35 dB below the output level of the wanted signal.

4.4.4.3.4 Presentation of the results

If this measurement is applied, the results are expressed in terms of carrier-to-interference ratio in dB and should comply with the performance criterion given in 4.4.2, with the appropriated test specification of Table 9.

4.4.4.4 Immunity of outdoor units to image frequency signals

4.4.4.4.1 Method of measurement

The immunity to image frequency signals is given by the image frequency rejection ratio. It shall be measured for outdoor units used for the reception and conversion of TV-signals with output frequencies in the SAT-IF-range.

The measurement shall be made according to the method given in EN 61079-1:1993, 3.10.

4.4.4.4.2 Presentation of the results

The results are expressed in terms of image suppression ratio in dB and shall comply with the performance criterion given in 4.4.2, with the limits given in Table 10.

4.5 Screening effectiveness of passive equipment

4.5.1 General

The methods described are applicable to the measurement of screening effectiveness of passive equipment.

In the frequency range 5 MHz to 30 MHz, the "coupling unit" method is used.

In the frequency range 30 MHz to 1 000 MHz, the "absorbing clamp" method of EN 55013 is used.

In the frequency range 950 MHz to 25 GHz, the "substitution" method is used.

For equipment with an upper frequency limit of 1 000 MHz, the absorbing clamp method is used up to 1 000 MHz. For equipment with a lower frequency limit of 950 MHz, only the substitution method is used.

4.5.2 General measurement requirements

The measurement cables, coupling devices and terminations shall all be well-matched and well-screened. Test equipment shall be of 75 Ω impedance.

An indoor, or outdoor, site may be used. When indoors, a room of sufficient size shall be chosen, so that any reflecting and absorbing objects may be so positioned or sufficiently removed from the measuring set-up that they do not influence the results.

Measurements shall be made at the following ports:

- all RF-ports;
- all single or multiple wire connections (if any).

Measurements shall be made at a selection of frequencies chosen to give a realistic representation of the screening effectiveness throughout the operating frequency range.

4.5.3 Methods of measurements

4.5.3.1 Measurement of screening effectiveness in the frequency range 5 MHz to 30 MHz using the "coupling unit" method

4.5.3.1.1 Equipment required

According to 4.3.3.1.

4.5.3.1.2 Equipment layout and connections

According to 4.3.3.1.

The mains lead (if any) is also connected to a coupling unit.

4.5.3.1.3 Operating conditions

According to 4.3.3.1.

4.5.3.1.4 Measurement procedure

According to 4.3.3.1.

4.5.3.1.5 Presentation of the results

When passive equipment is tested, its screening effectiveness a_s shall be given in terms of the ratio, expressed in decibels, between the maximum power at the input of the equipment under test and the corrected highest measured conducted power at each frequency of measurement. The results shall comply with the limits given in Table 11.

4.5.3.2 Measurement of screening effectiveness in the frequency range 30 MHz to 1 000 MHz using the "absorbing clamp" method

4.5.3.2.1 Equipment required

According to 4.3.3.2.

4.5.3.2.2 Equipment layout and connections

According to 4.3.3.2.

4.5.3.2.3 Operating conditions

According to 4.3.3.2.

4.5.3.2.4 Measurement procedure

According to 4.3.3.2.

4.5.3.2.5 Presentation of results

When passive equipment is tested, its screening effectiveness a_s shall be given in terms of the ratio, expressed in decibels, between the maximum power at the input of the equipment under test and the highest measured radiated power at each frequency of measurement. The results shall comply with the limits given in Table 11.

4.5.3.3 Measurement of screening effectiveness in the frequency range 950 MHz to 25 GHz using the "substitution" method

4.5.3.3.1 Equipment required

According to 4.3.3.3.

4.5.3.3.2 Equipment layout and connections

According to 4.3.3.3.

4.5.3.3.3 Operating conditions

According to 4.3.3.3.

4.5.3.3.4 Measurement procedure

According to 4.3.3.3.

4.5.3.3.5 Presentation of results

When passive equipment is tested, its screening effectiveness a_s shall be given in terms of the ratio, expressed in decibels, between the maximum power at the input of the equipment under test and the highest measured radiated power at each frequency of measurement. The results shall comply with the limits of Table 11.

4.6 Electrostatic discharge immunity test for active equipment

4.6.1 General

The test method and the procedure shall be the direct contact method of EN 61000-4-2, according to EN 61000-6-1:2007, Table 1 – Immunity – Enclosure port – item 1.5: Electrostatic discharge.

4.6.2 Performance criterion B (according to EN 61000-6-1:2007)

The equipment shall continue to operate as intended after the test. No degradation of performance or loss of function is allowed below a performance level specified by the manufacturer, when the equipment is used as intended. The performance level may be replaced by a permissible loss of performance. During the test, degradation of performance however is allowed. No change of actual operating state or stored data is allowed.

The test specifications are given in 5.6.

4.7 Electrical fast transient/burst immunity test for AC power ports

The test method and the procedure shall be those given in EN 61000-4-4, according to EN 61000-6-1:2007, Table 4 – Immunity – Input and output AC power ports – item 4.5: Fast transients.

The test specifications are given in 5.7.

Performance criterion B according to 4.6.2.

4.8 Methods of measurement for telecom signal ports of multimedia network equipment

Telecom signal ports of multimedia network equipment (i.e. cable network equipment with additional telecom signal port(s)) shall be tested according to ETSI EN 300 386.

4.9 Measurement of indoor receiving antennas for broadcast signals

4.9.1 Indoor antennas with additional RF network input port

4.9.1.1 Operating conditions

The measurements shall be carried out with the EUT operating as intended (wanted signals at the additional RF network input port, output terminated with the nominal impedance) but with no radiated input signal to the antenna.

4.9.1.2 Active indoor antennas

Active indoor antennas (the active part of the indoor antenna) shall be measured according to 4.2, 4.3 and 4.6.

4.9.1.3 Passive indoor antennas

Passive indoor antennas (the passive part of the indoor antenna) shall be measured according to 4.5.

4.9.2 Indoor antennas without additional RF network input port

Simple indoor antennas (without additional RF network input port) do not fall under the scope of this standard. They shall meet the requirements of EN 55013 and EN 55020.

5 Performance requirements

5.1 General

5.1.1 Emission performance requirements

The disturbance level shall not exceed the limits specified in 5.2 and 5.3 when measured using the methods given in Clause 4. At the transition frequencies, the lower limit applies.

5.1.2 Immunity performance requirements

Equipment under test shall meet the performance criterion as specified in 4.4.2 under the presence of the disturbing levels/limit values specified in 5.4.

5.2 Disturbance voltages from equipment

5.2.1 Limits of mains terminal disturbance voltage

The limits of mains terminal disturbance voltage are laid down in Table 2. Measurement shall be made in accordance with 4.2.1.

Table 2 - Limits of mains terminal disturbance voltage

Frequency range MHz	Limit values dB(μ V)	
	Quasi peak	Average value
0,15 to 0,5	66 to 56 ^a	56 to 46 ^a
0,5 to 5	56	46
5 to 30	60	50
^a Decreasing linearly with the logarithm of the frequency.		

5.2.2 Limits of input terminal disturbance voltages

The limits of input terminal disturbance voltage are laid down in Table 3 and Table 4. Measurement shall be made in accordance with 4.2.3.

Table 3 - Limits of input terminal disturbance voltages for equipment directly connected to receiving antennas

Frequency range MHz	Disturbance frequency	Level (75 Ω) dB(μV)
30 to 3 000	Oscillator fundamental	46
30 to 3 000	Oscillator harmonics	46
30 to 3 000	Other frequencies	46

Table 4 - Limits of input terminal disturbance voltages for equipment directly connected to satellite outdoor units

Frequency range MHz	Disturbance frequency	Level (75 Ω) dB(μV)
30 to 3 000	Oscillator fundamental	60
30 to 3 000	Oscillator harmonics	60
30 to 3 000	Other frequencies	60

5.3 Radiation

5.3.1 Radiation from active equipment

Measurements shall be made in accordance with 4.3.3.1, 4.3.3.2 or 4.3.3.3.

The radiation level is measured with a receiver having measuring bandwidths and detectors as stated in Table 5 (reproduced from EN 55016-1-1:2010).

For single carrier measurements, other receivers can also be used.

Table 5 - Limits of radiated disturbance power

Frequency range MHz	Limit values dB(pW)	Measuring bandwidth kHz	Detector
5 to 30	27 – 20 ^{a b}	9	Quasi-peak
5 to 30	33 ^c	9	Quasi-peak
30 to 1 000 ^d	20	120	Quasi-peak
950 ^e to 2 500	43	1 000	Peak
2 500 to 25 000	57	1 000	Peak

NOTE The limit of 50 dB(μV) for disturbance voltages on the mains line in the frequency range 5 MHz to 30 MHz is corresponding to a radiated disturbance power of 33 dB(pW). To avoid different limits for the mains line and other ports the radiation requirements for equipment having a mains line is increased to 33 dB(pW).

^a Decreasing linearly with the logarithm of frequency.

^b For active equipment that is not powered via a mains line.

^c For mains powered equipment.

^d Applicable for equipment with an upper frequency limit ≤ 1 000 MHz.

^e Applicable for equipment with a lower frequency limit ≥ 950 MHz.

5.3.2 Local oscillator power at the outdoor unit input

The limit of local oscillator terminal power is laid down in Table 6. Measurement shall be made in accordance with 4.3.3.4.

Table 6 - Limit of local oscillator terminal power

Frequency range GHz	Level dB(pW)
2,5 to 25	30

5.4 Immunity of active equipment

5.4.1 External immunity to electromagnetic fields

5.4.1.1 Out-of-band immunity (modulated interfering signal)

The limits of out-of-band immunity are laid down in Table 7. They show the lowest level/field strength for compliance with performance criterion, given in 4.4.2. Measurement shall be made in accordance with 4.4.3.1.

Table 7 - Limits of out-of-band immunity

Frequency range MHz	Level (emf) dB(μ V)	Field strength dB(μ V/m)
0,15 to 80	125	---
80 to 1 000 ^a	---	125
950 ^b to 3 500	---	125
3 500 to 25 000	---	currently undefined

^a Applicable for equipment with an upper frequency limit \leq 1 000 MHz.
^b Applicable for equipment with a lower frequency limit \geq 950 MHz.

5.4.1.2 In-band immunity (unmodulated interfering signal)

Due to the assignment of the frequency range 790 MHz to 862 MHz to broadband wireless services a changed EMC environment in this frequency band has to be taken into account for active and passive cable network equipment. When wireless base stations and user equipment are communicating, the resulting radio signals may cause in-band disturbances due to higher field strength levels than previously encountered by cable network equipment.

The limits of in-band immunity are laid down in Table 8. They show the lowest level/field strength for compliance with performance criterion, given in 4.4.2. Measurement shall be made in accordance with 4.4.3.2.

Table 8 - Limits of in-band immunity

Frequency range MHz	Level (emf) dB(μV)	Field strength dB(μV/m)
0,15 to 80	106	---
80 to 1 000 ^a	---	106
790 to 862	---	120 ^c
950 ^b to 3 500	---	106
3 500 to 25 000	---	currently undefined

^a Applicable for equipment with an upper frequency limit ≤ 1 000 MHz.
^b Applicable for equipment with a lower frequency limit ≥ 950 MHz.
^c In cases where digitally modulated wanted signals are applied.

NOTE 1 For equipment exclusively connected directly to receiving antennas, in-band immunity requirements have not to be applied for the input frequency ranges.

NOTE 2 The external immunity of a deployed cable network may deviate from the external immunity of the equipment as a result of building attenuation, signal levels or installation quality, etc.

5.4.2 Internal immunity

The test specifications for internal immunity are laid down in Table 9. Measurement shall be made in accordance with 4.4.4.

Table 9 - Test specification for internal immunity

Frequency range MHz	Level
47 to 68	See Figure 14
87,5 to 108	See Figure 15
174 to 230	See Figure 16
470 to 862	See Figure 17
10 200 to 13 500 ^a	See Figure 12
10 200 to 13 000 ^b	See Figure 13

^a For FSS outdoor units.
^b For BSS outdoor units.

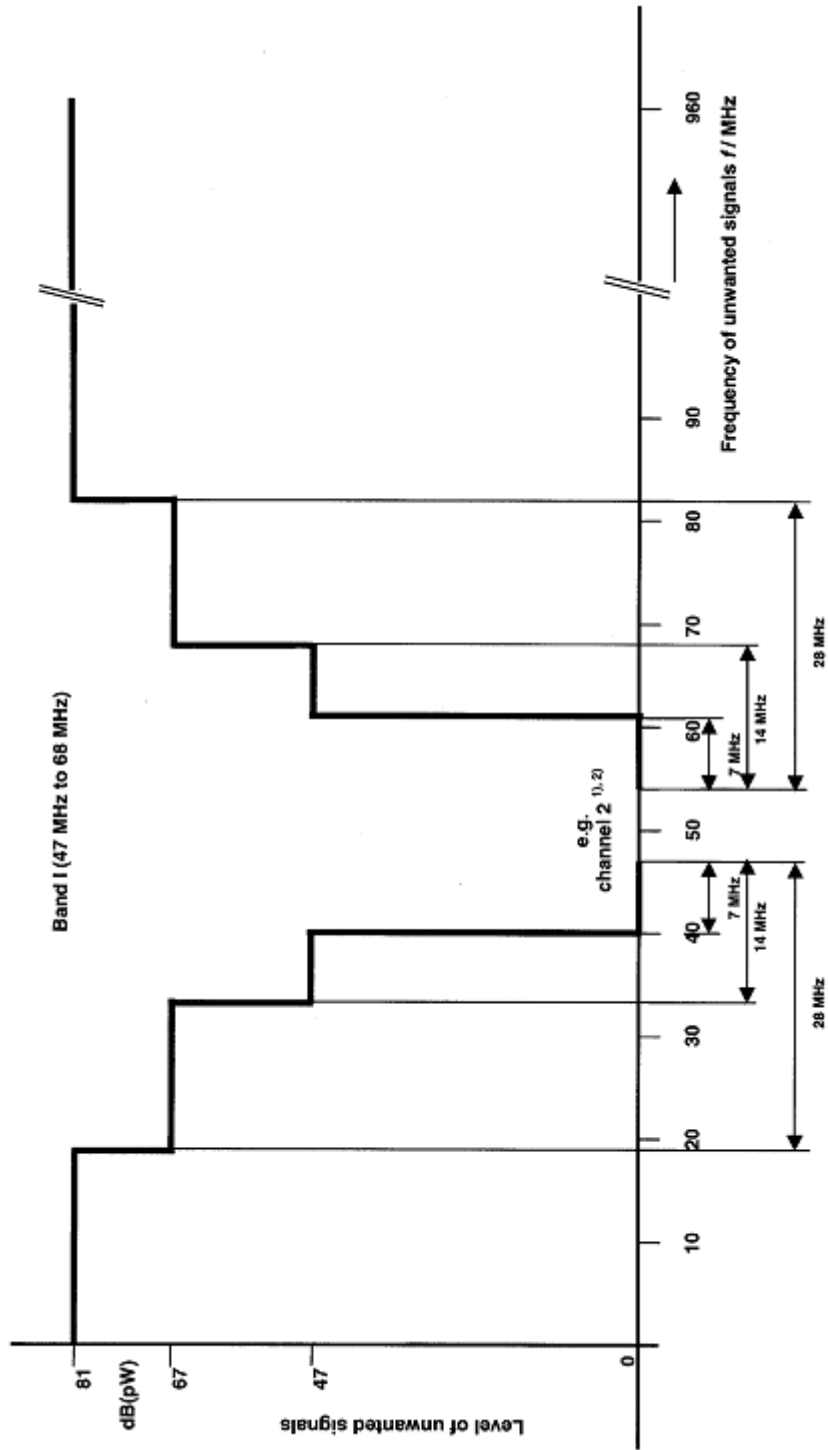

¹⁾ Depending on the nominal frequency range of the active equipment (single channel equipment / broadband equipment), each half of the curve shall be shifted to the relevant band edges. For multiband equipment, it may be necessary to combine the relevant limit curves (Figure 14 to Figure 17).

²⁾ Level of wanted signal according to 4.4.4.2.

Figure 14 - Levels of unwanted signals for the internal immunity of active equipment in Band I (47 MHz to 68 MHz)

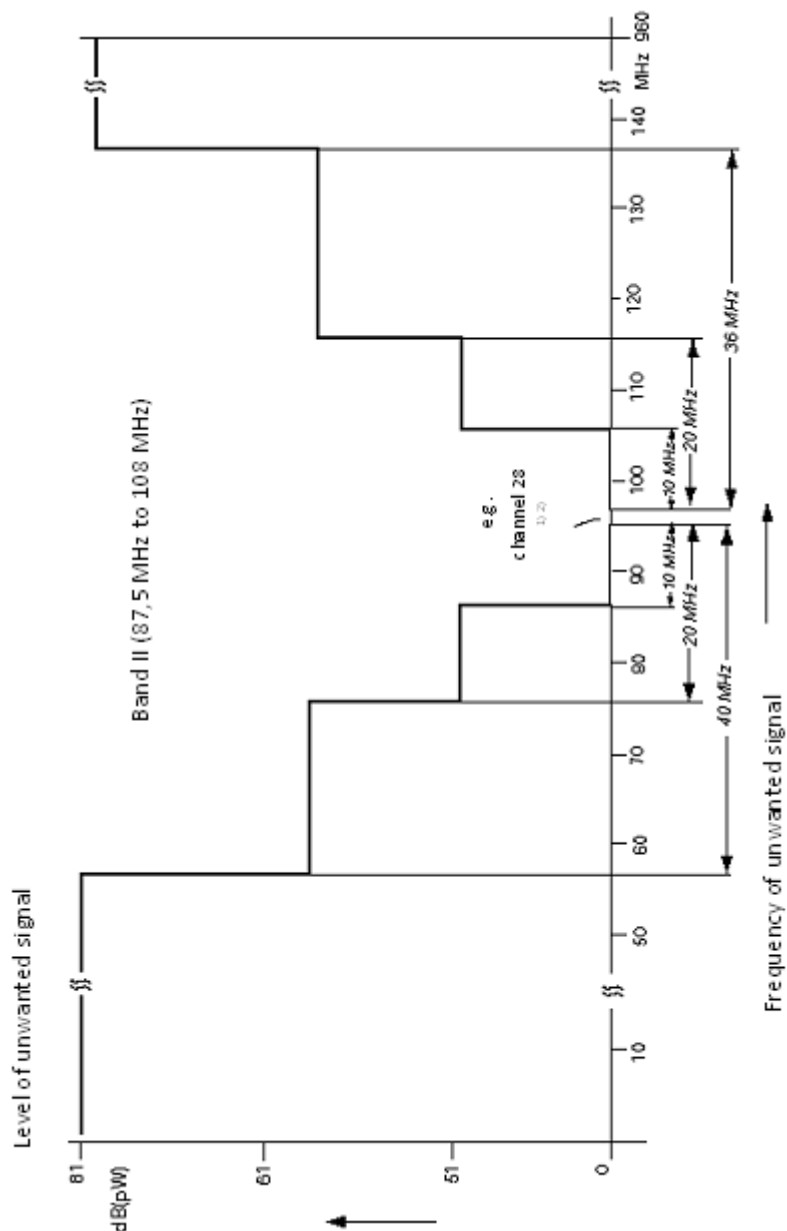

¹⁾ Depending on the nominal frequency range of the active equipment (single channel equipment / broadband equipment), each half of the curve shall be shifted to the relevant band edges. For multiband equipment, it may be necessary to combine the relevant limit curves (Figure 14 to Figure 17).

²⁾ Level of wanted signal according to 4.4.4.2.

Figure 15 - Levels of unwanted signals for the internal immunity of active equipment in Band II (87,5 MHz to 108 MHz)

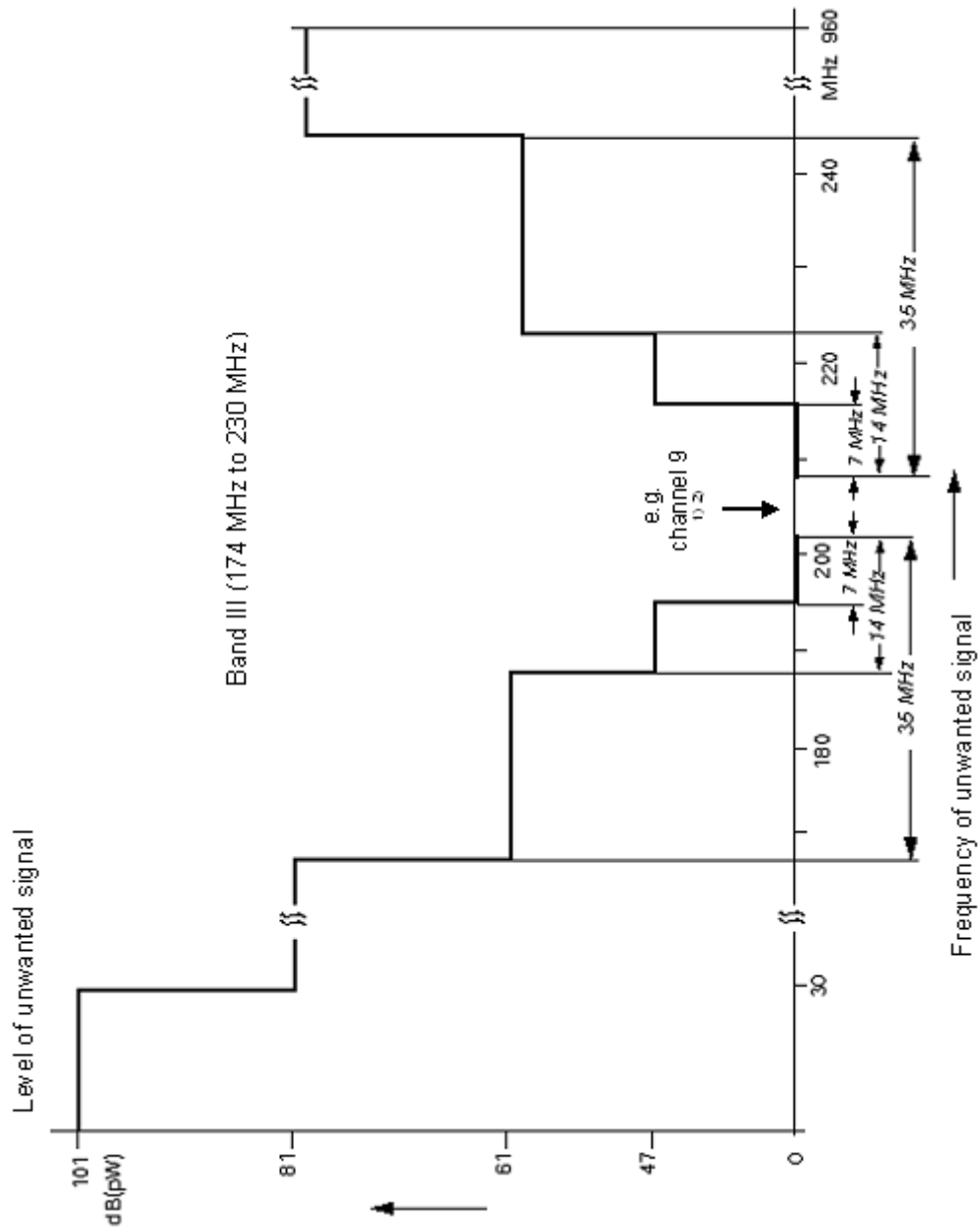

¹⁾ Depending on the nominal frequency range of the active equipment (single channel equipment / broadband equipment), each half of the curve shall be shifted to the relevant band edges. For multiband equipment, it may be necessary to combine the relevant limit curves (Figure 14 to Figure 17).

²⁾ Level of wanted signal according to 4.4.4.2.

Figure 16 - Levels of unwanted signals for the internal immunity of active equipment in Band III (174 MHz to 230 MHz)

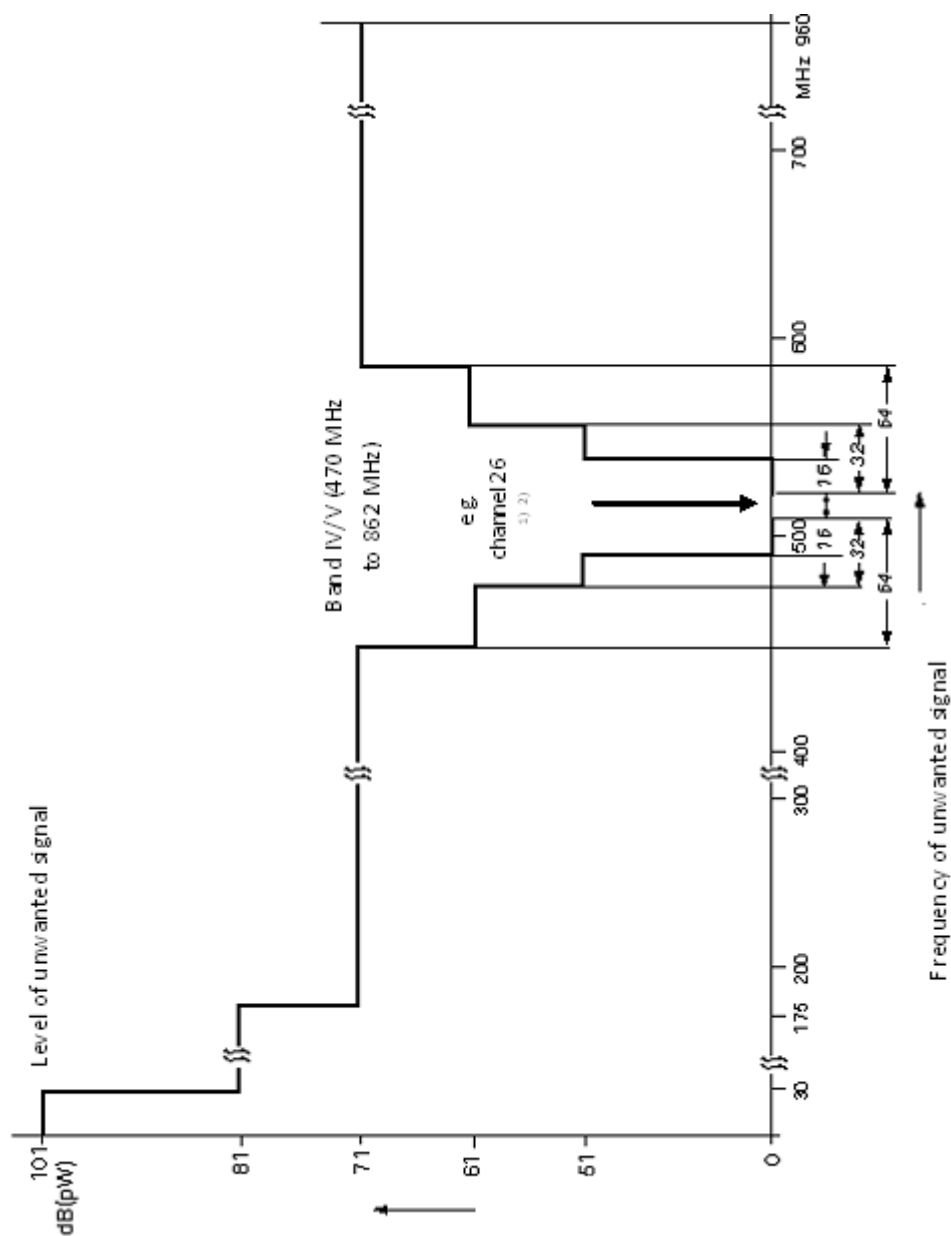

¹⁾ Depending on the nominal frequency range of the active equipment (single channel equipment / broadband equipment), each half of the curve shall be shifted to the relevant band edges. For multiband equipment, it may be necessary to combine the relevant limit curves (Figure 14 to Figure 17).

²⁾ Level of wanted signal according to 4.4.4.2

Figure 17 - Levels of unwanted signals for the internal immunity of active equipment in Band IV/V (470 MHz to 862 MHz)

5.4.3 Immunity of outdoor units to image frequency signals

The limits of immunity to image frequency signals in terms of image suppression ratio are laid down in Table 10. Measurement shall be made in accordance with 4.4.4.4.

Table 10 - Limits of immunity to image frequency signals in terms of image suppression ratio

Type of equipment	Output frequency MHz	Limit values dB
Outdoor units	950 to 3 500	40

5.5 Screening effectiveness of passive equipment

The limit values of screening effectiveness of passive equipment within the nominal frequency ranges are laid down in Table 11. Measurement shall be made in accordance with 4.5.3.1, 4.5.3.2 or 4.5.3.3.

Table 11 - Limits of screening effectiveness of passive equipment within the nominal frequency ranges

Frequency range MHz	Limit value dB	
	Class A	Class B
5 to 30	85	75
30 to 300	85	75
300 to 470	80	75
470 to 1 000 ^a	75	65
950 ^b to 3 500	55	50

^a Applicable for equipment with an upper frequency limit $\leq 1\,000$ MHz.
^b Applicable for equipment with a lower frequency limit ≥ 950 MHz.

For passive equipment an immunity level of 120 dB(μ V/m) in the frequency range 790 MHz to 862 MHz can only be realised by using class A equipment.

NOTE 1 For the specification of the limit values for the screening effectiveness it is assumed, that the average interfering field strength at the passive equipment will be 106 dB(μ V/m). Assuming a coupling factor of about 11 dB (at 175 MHz) and an average signal level in cable networks of 70 dB(μ V), a screening effectiveness of 85 dB is necessary to achieve an RF carrier-to-interference signal ratio of 60 dB (analogue modulation of the wanted signal).

NOTE 2 For the higher interfering field strength up to 120 dB(μ V/m) in the 790 MHz to 862 MHz frequency range due to wireless services the calculation is as follows: 120 dB(μ V/m) minus a coupling factor of about 25 dB (at 800 MHz) and a screening effectiveness of 75 dB for Class A equipment results in a signal level of the unwanted signal of 20 dB(μ V). Taking into account a minimum RF signal-to-interference signal ratio of 35 dB for digitally modulated signals this will lead to a wanted signal level of 55 dB(μ V), which is comparable to the average wanted signal value defined for active equipment in 4.4.3.2.

NOTE 3 The potential for the existence of high external field strengths (especially in the frequency range 790 MHz to 862 MHz due to broadband wireless services) means that the use of Class B equipment may not provide the protection necessary for future proofing of the network. Therefore only Class A equipment should be used in the planning and implementation of new networks.

NOTE 4 The external immunity of a deployed cable network may deviate from the external immunity of the equipment as a result of building attenuation, signal levels or installation quality, etc.

5.6 Electrostatic discharge immunity test for active equipment

The test specifications for electrostatic discharge immunity test for active equipment are laid down in Table 12. Measurements shall be made in accordance with 4.6.

Table 12 - Test specifications for electrostatic discharge immunity test for active equipment

Port	Charge voltage kV	Performance criterion
Enclosure	4	B

5.7 Electrical fast transient/burst immunity test for AC power ports

The test specifications for electrical fast transient/burst immunity test are laid down in Table 13. Measurements shall be made in accordance with 4.7.

Table 13 - Test specifications for electrical fast transient/burst immunity test

Port	Charge voltage kV	Performance criterion
AC power	1	B

5.8 Performance requirements for telecom signal ports of multimedia network equipment

Telecom signal ports of multimedia network equipment (i.e. cable network equipment with additional telecom signal port(s)) shall comply with the requirements of ETSI EN 300 386. The different port types and environmental conditions according to Table 14, which lead to different subclauses in ETSI EN 300 386 V1.5.1 (2010), have to be taken into account.

Table 14 - Port types and environmental conditions for EMC performance requirements and methods of measurement

Port type	Environmental condition / Place of EUT	Relevant subclause in ETSI EN 300 386 V1.5.1 (2010)
For outdoor signal lines	Inside telecommunication centres	7.2.1.2
	Other than telecommunication centres	7.2.2.2
For indoor signal lines	Inside telecommunication centres	7.2.1.3
	Other than telecommunication centres	7.2.2.3

5.9 Applicability of EMC performance requirements and methods of measurement to different types of equipment

Table 15 summarizes the different EMC performance requirements for emission, the related methods of measurement and the applicability to different types of cable network equipment.

Table 15 - Emission parameters

Parameter	Applicability	Test specification	Test set-up	Limits
Disturbance voltages in the frequency range from 150 kHz to 30 MHz	Equipment AC mains powered	See 4.2.1	See 4.2.1.3	See 5.2.1 Table 2
Disturbance voltages from equipment at the AC mains frequency and its harmonics	Equipment AC mains powered	See 4.3.2 and EN 61000-3-2	See 4.2.2 and EN 61000-3-2	See 4.2.2 and EN 61000-3-2
Measurement of input terminal disturbance voltage	Active equipment directly connected to receiving antennas or satellite outdoor units	See 4.2.3	See 4.2.3	See 5.2.2 Table 3 and Table 4
Radiation in the frequency range 5 MHz to 30 MHz	Active equipment	See 4.3.3	See 4.3.3.1 "coupling unit" method	See 5.3.1 Table 5
Radiation in the frequency range 30 MHz to 1 000 MHz	Active equipment	See 4.3.3	See 4.3.3.2 "absorbing clamp" method	See 5.3.1 Table 5
Radiation in the frequency range 950 MHz to 25 GHz	Active equipment	See 4.3.3	See 4.3.3.3 "substitution" method	See 5.3.1 Table 5
Measurement of local oscillator power	Outdoor unit input	See 4.3.3.4	See 4.3.3.4	See 5.3.2 Table 6

Table 16 summarizes the different EMC performance requirements for immunity and screening effectiveness, the related methods of measurement and the applicability to different types of cable network equipment.

Table 16 - Immunity and screening effectiveness parameters

Parameter	Applicability	Test specification	Test set-up	Performance criteria
External immunity to ambient fields: Out-of-band immunity	Active equipment	See 4.4.3.1 and Table 7	See 4.4.3.1	A See 4.4.2
External immunity to ambient fields: In-band immunity	Active equipment	See 4.4.3.2 and Table 8	See 4.4.3.2	A See 4.4.2
Internal immunity to out-of-band disturbing signals	Active equipment (RF amplifier, converter) in the frequency range 47 MHz to 862 MHz or 10,70 GHz to 12,75 GHz	See 4.4 and Table 9	See 4.4.4	A See 4.4.2
Internal immunity to in-band disturbing signals	Active equipment (RF amplifier, converter) in the frequency range 47 MHz to 862 MHz, single channel amplifiers in the frequency range 87,5 MHz to 108 MHz excluded (u.c.).	See 4.4.4.2 and Table 9	See 4.4.4.2	A See 4.4.2
Internal immunity to in-band disturbing signals	Single and multiple outdoor units in the frequency range 10,70 GHz to 12,75 GHz	See 4.4.4.3 and Table 9	See 4.4.4.3	A See 4.4.2
Immunity to image frequency signals	Outdoor units for the reception and conversion of FM- and TV-signals with output frequencies in the SAT-IF-range	See 4.4.4.4 and Table 10	See EN 61079-1:1993, 3.10	A See 4.4.2
Screening effectiveness in the frequency range 5 MHz to 30 MHz	Passive equipment within the nominal frequency ranges	See 4.5.3.1 and Table 11	See 4.3.3.1 "coupling unit" method	A See 4.4.2
Screening effectiveness in the frequency range 30 MHz to 1000 MHz	Passive equipment within the nominal frequency ranges	See 4.5.3.2 and Table 11	See 4.3.3.2 "absorbing clamp" method	A See 4.4.2
Screening effectiveness in the frequency range 950 MHz to 25 GHz	Passive equipment within the nominal frequency ranges	See 4.5.3.3 and Table 11	See 4.3.3.3 "substitution" method	A See 4.4.2
Electrostatic discharge	Active equipment	See 4.6 and Table 12	See 4.6 direct contact method	B See 4.6.2
Electrical fast transient/burst immunity test	Active equipment, AC mains powered	See 4.7 and Table 13	See 4.7	B See 4.6.2

Annex ZZ (informative)

Coverage of Essential Requirements of EU Directives

This European Standard has been prepared under a mandate given to CENELEC by the European Commission and the European Free Trade Association and within its scope the standard covers all relevant essential requirements as given in Article 1 of Annex I of the EU Directive 2004/108/EC.

Compliance with this standard provides one means of conformity with the specified essential requirements of the Directive(s) concerned.

WARNING - Other requirements and other EU Directives may be applicable to the products falling within the scope of this standard.

Bibliography

- EN 50083/EN 60728 (all parts), *Cable networks for television signals, sound signals and interactive services*
- EN 50083-8, *Cable networks for television signals, sound signals and interactive services — Part 8: Electromagnetic compatibility for networks*
- EN 50117 (all parts), *Coaxial cables*
- EN 55022, *Information technology equipment — Radio disturbance characteristics — Limits and methods of measurement (CISPR 22)*
- EN 55024, *Information technology equipment — Immunity characteristics — Limits and methods of measurement (CISPR 24)*
- EN 60728-1:2008, *Cable networks for television signals, sound signals and interactive services — Part 1: System performance of forward paths (IEC 60728-1:2007)*
- EN 60728-4, *Cable networks for television signals, sound signals and interactive services — Part 4: Passive wideband equipment for coaxial cable networks (IEC 60728-4)*
- EN 60728-5, *Cable networks for television signals, sound signals and interactive services — Part 5: Headend equipment (IEC 60728-5)*
- EN 60728-6, *Cable networks for television signals, sound signals and interactive services — Part 6: Optical equipment (IEC 60728-6)*
- EN 60728-10, *Cable networks for television signals, sound signals and interactive services — Part 10: System performance for return paths (IEC 60728-10)*
- EN 60966-1, *Radio frequency and coaxial cable assemblies — Part 1: Generic specification — General requirements and test methods (IEC 60966-1)*
- EN 60966-2-4, *Radio frequency and coaxial cable assemblies — Part 2-4: Detail specification for cable assemblies for radio and TV receivers — Frequency range 0 MHz to 3 000 MHz, IEC 61169-2 connectors (IEC 60966-2-4)*
- EN 60966-2-5, *Radio frequency and coaxial cable assemblies — Part 2-5: Detail specification for cable assemblies for radio and TV receivers — Frequency range 0 MHz to 1 000 MHz, IEC 61169-2 connectors (IEC 60966-2-5)*
- EN 60966-2-6, *Radio frequency and coaxial cable assemblies — Part 2-6: Detail specification for cable assemblies for radio and TV receivers — Frequency range 0 MHz to 3 000 MHz, IEC 61169-24 connectors (IEC 60966-2-6)*
- ETSI EN 301 489-4 V1.4.1, *Electromagnetic compatibility and Radio spectrum Matters (ERM); ElectroMagnetic Compatibility (EMC) standard for radio equipment and services; Part 4: Specific conditions for fixed radio links, Broadband Data Transmission System Base stations, ancillary equipment and services*
- IEC 60617 (all parts), *Graphical symbols for diagrams*
- CEPT Report 30, Report from CEPT to the European Commission in response to the Mandate on “The identification of common and minimal (least restrictive) technical conditions for 790-862 MHz for the digital dividend in the European Union”

British Standards Institution (BSI)

BSI is the independent national body responsible for preparing British Standards and other standards-related publications, information and services. It presents the UK view on standards in Europe and at the international level.

BSI is incorporated by Royal Charter. British Standards and other standardisation products are published by BSI Standards Limited.

Revisions

British Standards and PASs are periodically updated by amendment or revision. Users of British Standards and PASs should make sure that they possess the latest amendments or editions.

It is the constant aim of BSI to improve the quality of our products and services. We would be grateful if anyone finding an inaccuracy or ambiguity while using British Standards would inform the Secretary of the technical committee responsible, the identity of which can be found on the inside front cover. Similar for PASs, please notify BSI Customer Services.

Tel: +44 (0)20 8996 9001 Fax: +44 (0)20 8996 7001

BSI offers BSI Subscribing Members an individual updating service called PLUS which ensures that subscribers automatically receive the latest editions of British Standards and PASs.

Tel: +44 (0)20 8996 7669 Fax: +44 (0)20 8996 7001

Email: plus@bsigroup.com

Buying standards

You may buy PDF and hard copy versions of standards directly using a credit card from the BSI Shop on the website www.bsigroup.com/shop. In addition all orders for BSI, international and foreign standards publications can be addressed to BSI Customer Services.

Tel: +44 (0)20 8996 9001 Fax: +44 (0)20 8996 7001

Email: orders@bsigroup.com

In response to orders for international standards, BSI will supply the British Standard implementation of the relevant international standard, unless otherwise requested.

Information on standards

BSI provides a wide range of information on national, European and international standards through its Knowledge Centre.

Tel: +44 (0)20 8996 7004 Fax: +44 (0)20 8996 7005

Email: knowledgecentre@bsigroup.com

BSI Subscribing Members are kept up to date with standards developments and receive substantial discounts on the purchase price of standards. For details of these and other benefits contact Membership Administration.

Tel: +44 (0)20 8996 7002 Fax: +44 (0)20 8996 7001

Email: membership@bsigroup.com

Information regarding online access to British Standards and PASs via British Standards Online can be found at www.bsigroup.com/BSOL

Further information about British Standards is available on the BSI website at www.bsi-group.com/standards

Copyright

All the data, software and documentation set out in all British Standards and other BSI publications are the property of and copyrighted by BSI, or some person or entity that own copyright in the information used (such as the international standardisation bodies) has formally licensed such information to BSI for commercial publication and use. Except as permitted under the Copyright, Designs and Patents Act 1988 no extract may be reproduced, stored in a retrieval system or transmitted in any form or by any means – electronic, photocopying, recording or otherwise – without prior written permission from BSI. This does not preclude the free use, in the course of implementing the standard, of necessary details such as symbols, and size, type or grade designations. If these details are to be used for any other purpose than implementation then the prior written permission of BSI must be obtained. Details and advice can be obtained from the Copyright & Licensing Department.

Tel: +44 (0)20 8996 7070

Email: copyright@bsigroup.com

BSI

389 Chiswick High Road London W4 4AL UK

Tel +44 (0)20 8996 9001

Fax +44 (0)20 8996 7001

www.bsigroup.com/standards