

Measurement of fluid flow in closed conduits — Methods of evaluating the performance of electromagnetic flow-meters for liquids

The European Standard EN 29104:1993 has the status of a
British Standard

UDC 532.57.082.74:532.542

Confirmed
January 2008

Committees responsible for this British Standard

The preparation of this British Standard was entrusted by the Industrial-process Measurement and Control Standards Policy Committee (PCL/-) to Technical Committee PCL/2, upon which the following bodies were represented:

British Compressed Air Society
 British Gas plc
 Department of Energy (Gas and Oil Measurement Branch)
 Department of Trade and Industry (National Engineering Laboratory)
 Electricity Industry in United Kingdom
 Energy Industries Council
 GAMBICA (BEAMA Ltd.)
 Institute of Measurement and Control
 Institute of Petroleum
 Institute of Trading Standards Administration
 Institution of Mechanical Engineers
 Society of British Gas Industries
 Water Services Association of England and Wales

The following bodies were also represented in the drafting of the standard, through subcommittees and panels:

Engineering Equipment and Materials Users Association
 United Kingdom Atomic Energy Authority
 Water Research Centre

This British Standard, having been prepared under the direction of the Industrial-process Measurement and Control Standards Policy Committee, was published under the authority of the Standards Board and comes into effect on 31 October 1991

© BSI 12-1999

The following BSI references relate to the work on this standard:
 Committee reference PCL/2
 Draft for comment 89/25907 DC

Amendments issued since publication

Amd. No.	Date	Comments
7980	October 1993	Indicated by a sideline in the margin

ISBN 0 580 20143 0

Contents

	Page
Committees responsible	Inside front cover
National foreword	ii
Foreword	2
Text of EN 29104	3
Publication(s) referred to	Inside back cover

National foreword

This British Standard has been prepared under the direction of the Industrial-process Measurement and Control Standards Policy Committee. It is identical with ISO 9104:1991 “*Measurement of fluid flow in closed conduits — Methods of evaluating the performance of electromagnetic flow-meters for liquids*”, published by the International Organization for Standardization (ISO).

In 1993 the European Committee for Standardization (CEN) accepted ISO 9104:1991 as European Standard EN 29104:1993. As a consequence of implementing the European Standard this British Standard is renumbered as BS EN 29104 and any reference to BS 7526:1991 should be read as a reference to BS EN 29104.

Cross-references

International Standard	Corresponding British Standard
ISO 3966:1977	BS 1042 <i>Measurement of fluid flow in closed conduits</i> Section 2.1:1983 <i>Method using Pitot static tubes</i> (Identical)
ISO 4006:1991	BS 5875:1991 <i>Glossary of terms and symbols for measurement of fluid flow in closed conduits</i> (Identical)
BS 4185:1980	BS 6199 <i>Measurement of liquid flow in closed conduits using weighing and volumetric methods</i> Part 1:1981 <i>Weighing method</i> (Identical)
ISO 5168:1978 ^a	BS 5844:1980 <i>Methods of measurement of fluid flow: estimation of uncertainty of a flow-rate measurement</i> (Identical) BS 7118 <i>Measurement of fluid flow: assessment of uncertainty in the calibration and use of flow measurement devices</i>
ISO 7066-1:1989	Part 1:1990 <i>Linear calibration relationships</i> (Identical)
ISO 7066-2:1988	Part 2:1989 <i>Non-linear calibration relationships</i> (Identical)
ISO 8316:1987	BS 6199 <i>Measurement of liquid flow in closed conduits using weighing and volumetric methods</i> Part 2:1988 <i>Method for measurement by collection of the liquid in a volumetric tank</i> (Identical)
IEC 68	BS 2011 <i>Environmental testing</i>
IEC 68-2-3:1969	Part 2.1Ca:1977 <i>Test Ca. Damp heat, steady state</i> (Identical)
IEC 68-2-4:1960 ^b	
IEC 68-2-6:1982	Part 2.1Fc:1983 <i>Test Fc. Vibration (sinusoidal)</i> (Identical)
IEC 68-2-27:1972	Part 2.1Ea:1988 <i>Test Ea. Shock</i> (Identical)
IEC 770:1984	BS 4509:1985 <i>Methods for evaluating the performance of transmitters for use in industrial-process control systems</i> (Identical)

^a Reference in the text to ISO 5168 is to the revision currently in preparation. It is envisaged that, when the revised edition of ISO 5168 is published, a revised edition of BS 5844 will be published.

^b IEC 68-2-4:1960 has now been replaced by IEC 68-2-30:1980. BS 2011 “*Environmental testing — Part 2.1Db:1981 Test Db and guidance: Damp heat, cyclic (12 + 12 hour cycle)*” is identical with IEC 68-2-30:1980.

The Technical Committee has reviewed the provisions of ISO 6817 and IEC 160, to which reference is made in the text, and has decided that they are acceptable for use in conjunction with this standard.

There are no related British Standards to these standards.

A British Standard does not purport to include all the necessary provisions of a contract. Users of British Standards are responsible for their correct application.

Compliance with a British Standard does not of itself confer immunity from legal obligations.

Summary of pages

This document comprises a front cover, an inside front cover, pages i to iv, the EN title page, pages 2 to 20, an inside back cover and a back cover.

This standard has been updated (see copyright date) and may have had amendments incorporated. This will be indicated in the amendment table on the inside front cover.

UDC 532.57.082.74:532.542

Descriptors: Liquid flow, pipe flow, flow measurement, electromagnetic equipment, flowmeters, tests, performance tests

English version

Measurement of fluid flow in closed conduits — Methods of evaluating the performance of electromagnetic flow-meters for liquids

(ISO 9104:1991)

Mesure de débit des fluides dans les conduites
fermées — Methodes d'évaluation de la
performance des débitmètres
électromagnétiques utilisés pour les liquides
(ISO 9104:1991)

Durchflußmessung von Fluiden in
geschlossenen Leitungen — Verfahren zur
Beurteilung des Betriebsverhaltens von
magnetisch-induktiven Durchflußmeßgeräten
für Flüssigkeiten
(ISO 9104:1991)

This European Standard was approved by CEN on 1993-06-18. CEN members are bound to comply with the CEN/CENELEC Internal Regulations which stipulate the conditions for giving this European Standard the status of a national standard without any alteration.

Up-to-date lists and bibliographical references concerning such national standards may be obtained on application to the Central Secretariat or to any CEN member.

The European Standard exists in three official versions (English, French, German). A version in any other language made by translation under the responsibility of a CEN member into its own language and notified to the Central Secretariat has the same status as the official versions.

CEN members are the national standards bodies of Austria, Belgium, Denmark, Finland, France, Germany, Greece, Iceland, Ireland, Italy, Luxembourg, Netherlands, Norway, Portugal, Spain, Sweden, Switzerland and United Kingdom.

CEN

European Committee for Standardization
Comité Européen de Normalisation
Europäisches Komitee für Normung

Central Secretariat: rue de Stassart 36, B-1050 Brussels

Foreword

In 1991, ISO 9104:1991 *Measurement of fluid flow in closed conduits — Methods of evaluating the performance of electromagnetic flow-meters for liquids* was submitted to the CEN Primary Questionnaire procedure.

Following Resolution BT C 42/1992, ISO 9104:1991 was submitted to the formal vote; the result was positive.

This European Standard shall be given the status of a national standard, either by publication of an identical text or by endorsement, at the latest by December 1993, and conflicting national standards shall be withdrawn at the latest by December 1993.

According to the CEN/CENELEC Internal Regulations, the following countries are bound to implement this European Standard: Austria, Belgium, Denmark, Finland, France, Germany, Greece, Iceland, Ireland, Italy, Luxembourg, Netherlands, Norway, Portugal, Spain, Sweden, Switzerland and the United Kingdom.

NOTE The European references to international publications are given in Annex ZA (normative).

Contents

	Page
Foreword	2
Introduction	3
1 Scope	3
2 Normative references	3
3 Definitions	4
4 General testing procedure	4
5 Evaluation of the effect of an influence quality	8
6 Tests for the evaluation of the effects of other influence quantities	16
Annex A (informative) Bibliography	19
Annex ZA (normative) Normative references to international publications with their relevant European publications	20
Figure 1 — Sample calibration showing distribution of test points	8
Figure 2 — Typical circuit arrangements for upstream gate valve tests	9
Figure 3 — Examples showing the effect of an upstream gate valve on three electromagnetic meters of DN 500 (based on real data)	11
Figure 4 — Annular or segmental obstructions used to determine the effects of a disturbance in the inlet flow on the response of the flow-meter	13
Figure 5 — General test circuit	14
Figure 6 — Test of the effect of a) mains frequency common-mode voltage (voltage applied between the earth of the primary and secondary devices) and b) mains frequency voltage between neutral and primary earth (voltage applied between earth and mains, if practicable)	15
Figure 7 — Test of the effect of mains frequency voltage between earth and output terminals	16
Figure 8 — Test of the effect of a.c. currents on earthed connection between primary and secondary devices	17
Figure 9 — Test of the effect of series-mode signals at the supply frequency	18
Figure 10 — Test of the effect of stray currents within the liquid	18
Table 1	6
Table 2	7
Table 3	7
Table 4	12

Introduction

The methods of evaluation specified in this International Standard are intended for use by manufacturers to determine the performance of their products and by users or independent testing establishments to verify manufacturer's performance specifications and to demonstrate suitability of application.

The test conditions specified in this International Standard, for example the range of ambient temperatures and the power supply, represent those which commonly arise during use. Consequently, the values specified herein should be used where no other values are specified by the manufacturer.

The tests specified in this International Standard are not necessarily sufficient for instruments specifically designed for unusually arduous duties. Conversely, a restricted series of tests may be suitable for instruments designed to perform within a limited range of conditions.

1 Scope

1.1 This International Standard recommends methods of test for the evaluation of the performance of electromagnetic flow-meters for liquids flowing in closed conduits. It specifies a uniform procedure to verify the performance characteristics when the flow-meter is subjected to identified influence quantities and methods of representing the results of performance measurements.

NOTE 1 When a full evaluation in accordance with this International Standard is not required, those tests which are required should be performed and the results reported in accordance with those parts of this International Standard which are relevant.

1.2 This International Standard applies only to industrialized pipe-mounted electromagnetic flow-meters. It is not applicable to insertion-type flow-meters, liquid-metal flow-meters and medical flow-meters, although some of the tests described may be applied to such instruments if agreed to between the manufacturer and the user or evaluating body.

2 Normative references

The following standards contain provisions which, through reference in this text, constitute provisions of this International Standard. At the time of publication, the editions indicated were valid. All standards are subject to revision, and parties to agreements based on this International Standard are encouraged to investigate the possibility of applying the most recent editions of the standards indicated below. Members of IEC and ISO maintain registers of currently valid International Standards. ISO 3966:1977, *Measurement of fluid flow in closed conduits — Velocity area method using Pitot static tubes*.

ISO 4006:1991, *Measurement of fluid flow in closed conduits — Vocabulary and symbols*.

ISO 4185:1980, *Measurement of liquid flow in closed conduits — Weighing method*.

ISO 5168:—, *Measurement of fluid flow — Evaluation of uncertainties*¹⁾.

ISO 6817:—, *Measurement of conductive liquid flow in closed conduits — Method using electromagnetic flow-meters*²⁾.

ISO 7066-1:1989, *Assessment of uncertainty in the calibration and use of flow measurement devices — Part 1: Linear calibration relationships*.

ISO 7066-2:1988, *Assessment of uncertainty in the calibration and use of flow measurement devices — Part 2: Non-linear calibration relationships*.

ISO 8316:1987, *Measurement of liquid flow in closed conduits — Method by collection of the liquid in a volumetric tank*.

IEC 68-2-3:1969, *Basic environmental testing procedures — Test Ca: Damp heat, steady state*.

IEC 68-2-4:1960, *Basic environmental testing procedures — Test D: Accelerated damp heat*.

IEC 68-2-6:1982, *Basic environmental testing procedures — Test Fc and guidance: Vibration (sinusoidal)*.

IEC 68-2-27:1972, *Basic environmental testing procedures — Test Ea: Shock*.

¹⁾ To be published. (Revision of ISO 5168:1978)

²⁾ To be published. (Revision of ISO 6817:1980)

3 Definitions

For the purposes of this International Standard, the definitions given in ISO 4006 apply. The following definitions are given only for terms used with a special meaning or for terms the meaning of which might be usefully recalled.

3.1 electromagnetic flow-meter

flow-meter which creates a magnetic field perpendicular to the flow, so enabling the flow-rate to be deduced from induced electromotive force (e.m.f) produced by the motion of a conducting fluid in the magnetic field. The electromagnetic flow-meter consists of a primary device and one or more secondary devices

3.2 primary device

device containing the following elements:

- an electrically insulating meter tube through which the conductive fluid to be metered flows,
- one or more pairs of electrodes, diametrically opposed, across which the signal generated in the fluid is measured, and
- an electromagnet for producing a magnetic field in the meter tube.

the primary device produces a signal proportional to the flow-rate and in some cases a reference signal

3.3 secondary device

equipment which contains the circuitry which extracts the flow signal from the electrode signal and converts it to a standard output signal directly proportional to the flow-rate. This equipment may be mounted on the primary device

3.4 meter tube

pipe section of the primary device through which the fluid to be measured flows; its inner surface is usually electrically insulating

3.5 meter electrodes

one or more pairs of contacts or capacitor plates by means of which the induced voltage is detected

3.6 lower range value

lowest value of the measured variable that a device is adjusted to measure

3.7 upper range value

highest value of the measured variable that a device is adjusted to measure

3.8 span

algebraic difference between the upper and lower range values. For example, the span is equal to 16 mA when the range is 4 mA to 20 mA

3.9 common mode voltage

voltage which exists equally between each electrode and a reference potential

3.10 reference signal

signal which is proportional to the magnetic flux created in the primary device and which is compared in the secondary device with the flow signal

3.11 output signal

output from the secondary device which is a function of the flow-rate

3.12 full-scale flow-rate

flow-rate corresponding to the maximum output signal

3.13 referee measurements

measurements repeated under closely controlled atmospheric conditions when the correction factors to adjust parameters, sensitive to atmospheric conditions, to their standard atmosphere values are unknown and when measurements under the recommended range of ambient atmospheric conditions are unsatisfactory

4 General testing procedure

Most evaluation tests for electromagnetic flow-meters are carried out with the liquid flowing through both the flow-meter and the standard calibration facility or reference flow-meter. Care shall be taken to ensure a mean steady flow in the test circuit, independently of the rapid fluctuations in local velocities due to turbulence which always occurs in the range of Reynolds numbers peculiar to industrial flow conditions. Furthermore, the measurement uncertainty of the reference flow-meter or calibration facility should be taken into account when estimating the measurement uncertainty of the electromagnetic flow-meter under test.

It will be appreciated that the closest communication should be maintained between the evaluating body and the manufacturer. Note shall be taken of the manufacturer's specifications for the instrument when the test programme is being decided, and the manufacturer should be invited to comment on both the test programmes and the results.

4.1 General requirements

4.1.1 The flow shall be steady.

4.1.2 At the inlet of the upstream straight pipe the flow should be axisymmetric and free from significant pulsation and swirl.

4.1.3 The reference flow-meter or calibration standard for the measurement of flow-rate or quantity shall conform to the requirements of ISO 4185 or ISO 8316, or any subsequent International Standards covering reference standards for the measurement of liquid flow.

NOTE 2 It is recognized that the reference standards used for flow measurement are of various types. Those devices which measure directly in terms of the fundamental units of mass, length and time are more commonly referred to as primary standards. Other devices, including some flow-meters which are calibrated against primary standards, can be used to measure flow-rate for calibration purposes if they display high reproducibility. These devices are commonly referred to as secondary standards.

Future developments in liquid flow measurement may produce reference standards displaying a high degree of accuracy. These developments are recognized provided that the accuracy of these devices is traceable to fundamental measurements and the devices have been thoroughly investigated as to their uncertainty and the influence that they have on the calibration of the device under test.

4.1.4 The reference flow-meter or calibration standard shall be of suitable range to cover the range of flow for the flow-meter under test. Should the flow-meter be required to be installed in more than one test apparatus, then both (all) installations shall be described.

The accuracy rating of the reference standards system should preferably be at least three times better than that of the equipment under test.

4.1.5 The installation and reference standards shall be described in detail, including the traceability of the reference standards and the extent of the uncertainty in their indication and that of any other devices which may be part of the reference standards system. The assessment of the uncertainty in the flow measurement shall be in accordance with ISO 5168 and ISO 7066-1 and ISO 7066-2.

4.1.6 The conduit containing the liquid shall be full at all times. The liquid shall comply with the parameters defined in 4.3.

4.1.7 Any adjustments to the flow-meter during the test shall be reported and the effects of these adjustments on the performance under reference conditions should be determined and be stated as percentages of the output span.

4.1.8 There are several parameters which may affect the performance of an electromagnetic flow-meter, and in general the tests should be carried out by changing these one at a time, while ensuring that the remainder do not vary. It may be necessary to restrict the variation in interacting parameters by suitable means.

4.2 Installation

4.2.1 Pipe installation

The primary and secondary devices of the electromagnetic flow-meter should be installed in accordance with the manufacturer's instructions and ISO 6817.

The meter tube shall be full of liquid during all tests. To achieve this, the pipework circuit in which the primary device is mounted shall include adequate provision for the removal of gases collecting in it.

If the manufacturer's instruction recommends the use of grounding rings, this should be complied with and reported.

Where there is no manufacturer's recommendation for connecting pipe material, it will be necessary to establish the effects on performance of using different pipe materials.

Examples of materials are

- plastic pipe (which is electrically non-conducting and non-magnetic),
- steel pipe (which is electrically conducting and magnetic),
- stainless steel pipe (which is electrically conducting and non-magnetic).

The effects shall be stated as percentages of the output span.

In all cases, the manufacturer's mounting instructions for the measuring equipment shall be observed.

In the absence of manufacturer's recommendations, the flow-meter shall be installed in piping having a nominal size and nominal internal diameter in accordance with that of its upstream and downstream connections. The internal diameter of the pipe which is connected with the flow-meter shall not be smaller than the internal diameter of the flow-meter and should not exceed the internal diameter of the flow-meter by more than 3 %.

The primary device shall be installed in a straight pipe, at a distance of at least 10 times the nominal diameter (10 DN) from any upstream disturbance and 5 DN from any downstream disturbance. If required, a flow straightener should be used to eliminate swirl. Tests should never be conducted downstream of throttling points (e.g. valves or partially opened gate) (see the note to 5.2.3.2).

The connection between the pipe and the flow-meter shall be such that the sealing device does not protrude into the flow stream.

In the case of a primary device without flanges, and which is therefore connected between two flanges, care should be taken to mount it as concentrically as possible.

If there is a possibility of surrounding materials influencing the meter's magnetic field, the advice of the manufacturer should be sought.

4.2.2 Electrical installation

The potential of the metered liquid and the primary device should be at the same level, preferably ground potential. The connection between the liquid and the primary device housing may be made by direct contact with the adjacent conducting piping or by means of an earthing ring at both ends of the primary device.

The manufacturer's instructions shall be carefully followed for interconnections between the primary device and the secondary device. Instructions for connections to the power supply shall be followed.

4.3 Test liquid

Since the properties of the test liquid may affect the flow-meter characteristics, it is common practice to use water at conditions which have negligible effect. Water at a temperature between 4 °C and 35 °C, free from entrained air and magnetic particles, and reasonably clear of visible particles is acceptable. For other liquids, their type (including their tradename), viscosity, density and conductivity shall be known or determined immediately before and after the test.

4.3.1 Air entrainment

The test liquid shall be free from entrained air and the test pressure shall be sufficiently high to maintain the liquid above its vapour pressure and to prevent any dissolved gases in the liquid coming out of solution at any point in the piping system.

4.3.2 Conductivity range

The conductivity of the test liquid should be within the range of 5 mS/m (50 µS/cm) to 500 mS/m (5 000 µS/cm) or as otherwise specified by the manufacturer.

4.4 Environmental test conditions

The test conditions specified in this International Standard are in accordance with IEC 160.

Tests and calibrations should be carried out at the reference conditions specified unless otherwise stated; all specifications given in this International Standard refer to these reference conditions.

4.4.1 Standard reference ambient conditions

For the purposes of this International Standard, the standard reference atmosphere shall comply with the following specifications:

temperature:	20 °C
relative humidity:	65 %
atmospheric pressure:	1 013 mbar (101,3 kPa)

This standard reference atmosphere is that atmosphere to which values measured under any other ambient conditions are corrected by calculation. It is recognized that in many cases a correction factor for humidity is not possible. In such cases the standard reference atmosphere takes account of temperature and pressure only.

This atmosphere is equivalent to the normal reference operating conditions usually identified by the manufacturer.

4.4.2 Admissible range of ambient conditions for test measurements

The admissible range of ambient conditions for test measurements are given in Table 1.

Table 1

Condition	Admissible range
Temperature	4 °C to 35 °C
Relative humidity	35 % to 75 %
Atmospheric pressure	860 mbar (86 kPa) to 1 060 mbar (106 kPa)
Electromagnetic fields	Value to be stated if relevant

The maximum rate of change in temperature permissible during any test shall be 5 °C in 1 h.

4.4.3 Standard ambient conditions for referee measurements

When correction factors to adjust parameters sensitive to ambient conditions to their standard atmosphere values are unknown, and measurements under the admissible range of ambient conditions defined in 4.4.2 are unsatisfactory, repeated measurements under closely controlled ambient conditions should be conducted.

For the purposes of this International Standard, the ambient conditions shown in Table 2 are specified for referee measurements.

Table 2

Condition	Nominal value	Tolerance
Temperature	20 °C	± 2 °C
Relative humidity	65 %	± 5 %
Atmospheric pressure	860 mbar (86 kPa) to 1 060 mbar (106 kPa)	

For tropical, sub-tropical, or other special requirements, alternative referee atmospheres are given in IEC 160.

4.5 Nominal calibration conditions during tests

4.5.1 Reference values

The reference values shall be those specified by the manufacturer.

4.5.2 Tolerances

The tolerances on the electrical supply given in Table 3 shall apply unless closer tolerances are agreed between the user and the manufacturer.

Table 3

Variable	Tolerance
Rated voltage	± 1 %
Rated frequency	± 1 %
Harmonic distortion	less than 5 % [alternating current (a.c.) supply]
Ripple	less than 0,1 % [direct current (d.c.) supply]

4.5.3 Reference conditions for the connecting cable

The cable connecting the primary device to the secondary device shall be no longer than necessary and in accordance with the manufacturer's requirements.

4.6 Signal output

4.6.1 Analog

The load impedance shall be the arithmetic mean of the allowable maximum and minimum values, or the reference value specified by the manufacturer.

4.6.2 Frequency

The load impedance shall be the minimum allowable.

4.7 Zero checking

In order to check the flow-meter zero, means should be provided to stop the flow through the primary device, leaving it filled with stationary liquid.

4.8 Other conditions

Pressure fluctuations or pulsations which affect the measurement shall not be present.

4.9 Flow-meter calibration — Requirements and methods

The flow-meter under test and the associated test equipment shall be allowed to stabilize (i.e. a warm-up period of at least 15 min under steady-state environmental conditions should be allowed before any test is commenced). During this warm-up period the output should be approximately in the middle of its range. Environmental conditions which may influence test results shall be observed and recorded.

Unless otherwise specified, the flow-meter shall be adjusted for minimum error at the lower and upper range values before the test.

In order to evaluate the performance of the flow-meter system on a specified flow range, test points should be taken at flow-rate settings which are approximately 10 %, 25 %, 50 %, 75 % and 100 % of the span (see Figure 1). It is recommended that at least three measurements be taken at each test point.

From the readings at each flow-rate, an average output reading shall be computed. The difference between this value and the corresponding value of the reference standard system is an error relative to this standard. This deviation shall be expressed as a percentage of either the output span or the measured flow.

The uncertainty in the flow measurement shall be assessed in accordance with ISO 5168 and ISO 7066.

Where range-changing provision is incorporated in the equipment, the test procedure above shall be applied independently for each flow range but the compatibility of readings in appropriate regions of each range shall be cross-checked by changing ranges.

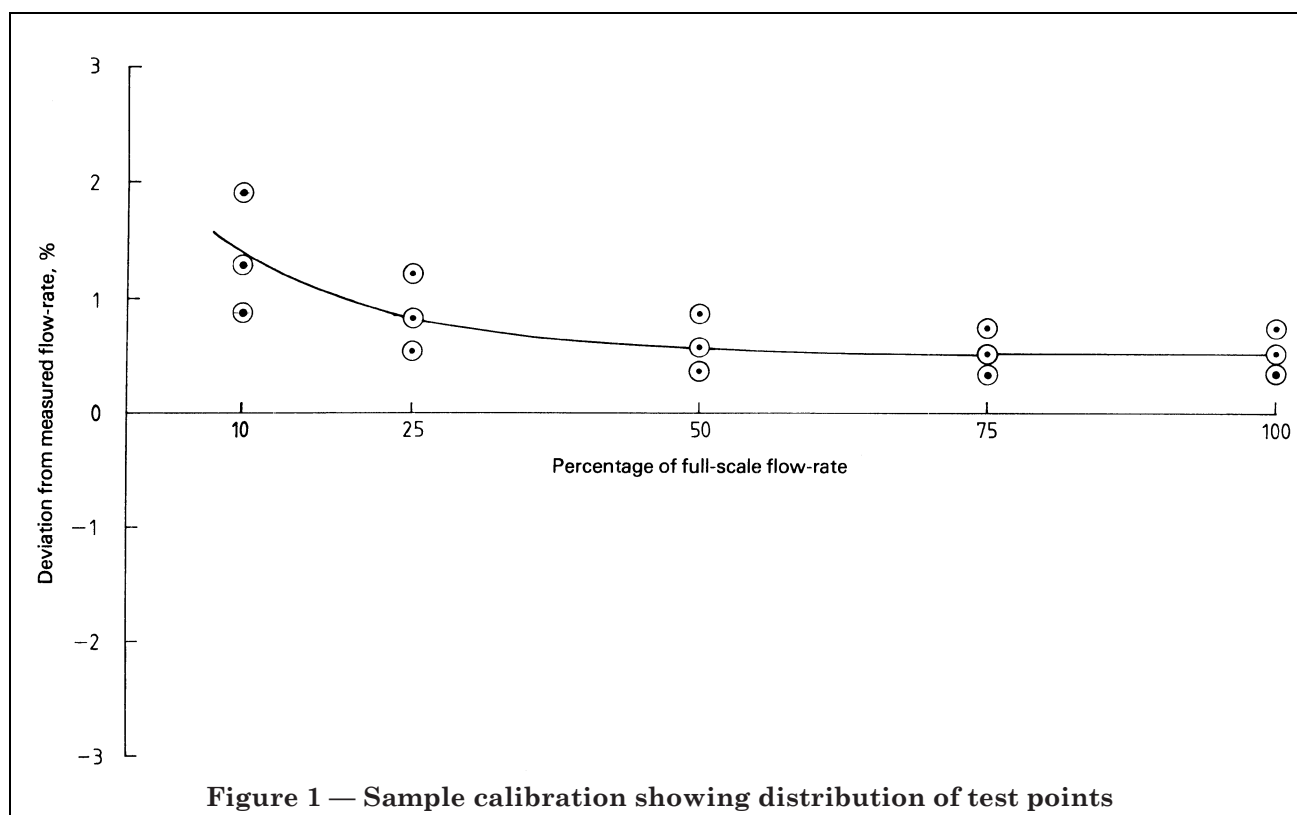

Figure 1 — Sample calibration showing distribution of test points

5 Evaluation of the effect of an influence quantity

5.1 General

There are two types of influence quantities to be considered, those affecting the liquid within the flow-meter primary element and those arising externally.

Internal effects include changes in, for example, the liquid temperature, the flow-velocity distribution and liquid conductivity.

External influence quantities include variations in temperature, humidity and barometric pressure and variations in supply current, voltage or frequency.

Unless otherwise stated, the effect of each of these quantities shall be assessed by determining the deviation of the meter-output from those obtained under reference conditions. The other conditions of use not under investigation shall remain constant at the reference value during the tests.

The evaluation shall be conducted, unless otherwise specified, at a flow-rate corresponding to a liquid velocity of 1 m/s with both the primary device and the secondary device connected to a common power supply. If the secondary device is fitted with an adjustable velocity range, this should be set to 2 m/s.

The output (analog) load impedance should be the maximum recommended by the manufacturer.

5.2 Internal influences

5.2.1 Temperature of liquid

The effect of changes in the liquid temperature shall be determined at different liquid temperatures, with the flow-meter at a constant ambient temperature. The temperature range should be sufficiently different from the reference test conditions to show clearly temperature influences and in each case sufficient time should be allowed to reach steady-state conditions. The tests shall be performed by measuring the steady-state changes in the lower range value and the span which result from the changes in liquid temperature. The effect shall be stated as a percentage of the output span. The details of the test should be agreed upon with the manufacturer. (See also 4.3.1.)

5.2.2 Conductivity of liquid

The effect of changes in the liquid electrical conductivity shall be determined at three different conductivities including the extreme values specified by the manufacturer. The effect shall be stated as a percentage of the output span.

NOTE 3 This test need only be considered necessary if the conductivity of the liquid is less than 5 mS/m (50 μ S/cm).

5.2.3 Velocity distribution

When a flow velocity profile which is significantly different from that in the original calibration is presented to the electrode plane, an electromagnetic flow-meter may exhibit a shift in calibration. The arrangement of pipe fittings upstream of the primary device is one of the factors which can contribute to the creation of a particular velocity profile. The following tests are devised to investigate the response of the flow-meter to velocity profiles emanating from some of the more common pipe circuit features which can be found in practice. It is recommended that, in order to establish the actual velocity profile immediately upstream of the flow-meter on test, a flow survey be carried out in accordance with ISO 3966.

The results of the tests described in 5.2.3.1 to 5.2.3.3 shall be presented for each test point as a percentage deviation from the reference flow-rate at the point. The reference conditions flow-rate should normally be obtained from an in-line wet calibration of the flow-meter installed in long straight pipe-lengths of uniform bore.

5.2.3.1 Pipe reducer

Tests shall be carried out with a concentric pipe reducer mounted firstly immediately adjacent to the flow-meter upstream flange and secondly at 5 DN upstream of the electrode plane of the flow-meter. The reducer should taper from a dimension of 2 DN to 1 DN. Although it is recommended that the reducer be 3 DN long with respect to the smaller diameter pipe, a commercially available fitting of another length may be used if agreed by the parties involved. Its dimensions shall be measured and entered into the test records.

Comparative measurements of the internal diameters of the reducer outlet and the flow-meter inlet shall be taken in at least two mutually perpendicular positions for each. The purpose of this test is to ensure that the inside diameter of the reducer outlet matches the inside diameter of the flow-meter inlet within an acceptable measurement tolerance (see 4.2.1).

The test readings should be taken at each of the recommended points within the flow range of the meter (see 4.9).

In special cases, tests utilizing offset reducers (or reducers which introduce steps in circuit pipework) may have to be carried out if such reducers are to be commonly used in practice. In these instances the design of the pipe reducer should be specified clearly and its dimensions measured and entered in the test records.

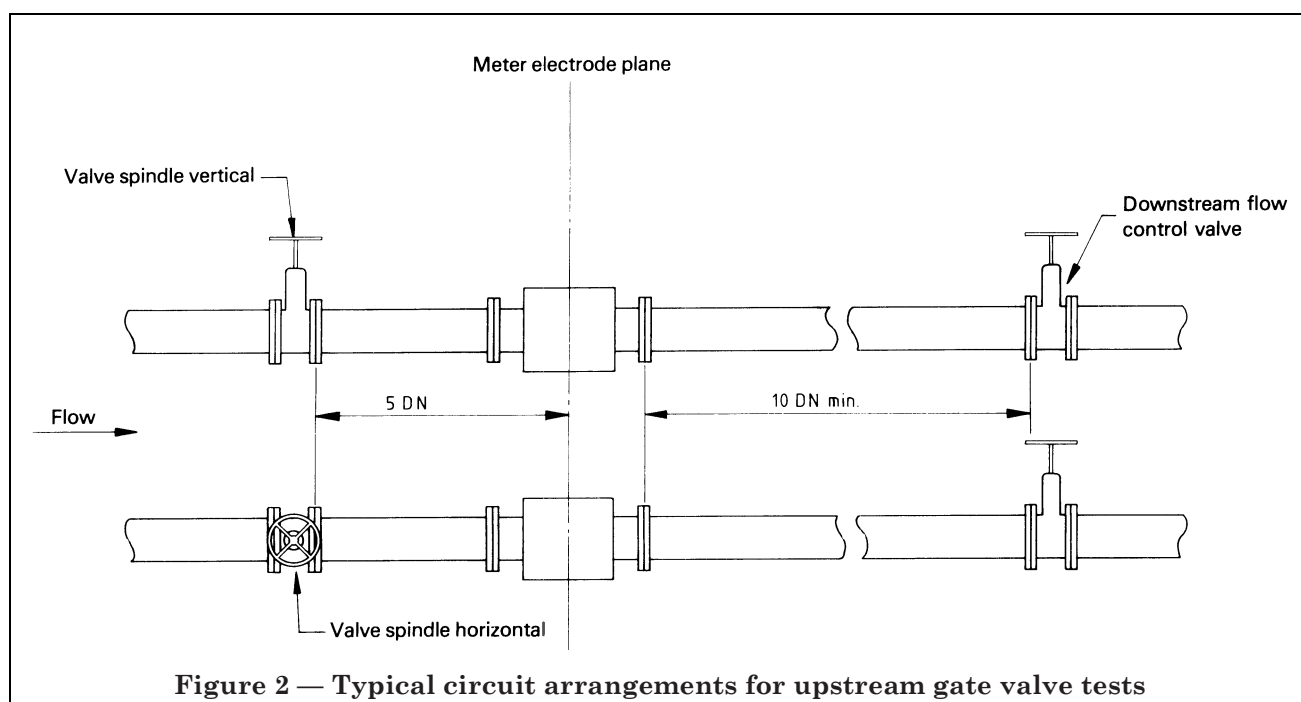

Figure 2 — Typical circuit arrangements for upstream gate valve tests

5.2.3.2 Upstream valve

A series of tests shall be made with a gate valve mounted firstly at 2 DN upstream from the electrode plane (or, if the meter is longer than 4 DN, adjacent to the flow-meter upstream flange) and secondly at 5 DN upstream from the electrode plane (see Figure 2). For both cases, tests should be carried out for the valve mounted with the spindle a) perpendicular to and b) parallel to an imaginary line joining the centres of the electrodes diametrically.

Two testing arrangements should be investigated. Results should be obtained firstly with the flow-rate being controlled using the upstream valve as a flow disturbance simulator and, secondly, with the upstream valve set at fixed positions³⁾ of 25 % and 50 % closed. In the latter arrangement the flow-rate is controlled by a downstream valve in the calibration rig pipe circuit.

The pressure in the pipe during these tests shall be maintained at a value sufficient to avoid any risk of cavitation.

In all test arrangements the test point sets should be obtained for at least four positions representative of the range of flow-rates which the constrictive testing arrangement and/or test rig capacity will permit [see Figure 3 a) and Figure 3 b)].

NOTE 4 The above pipe circuit arrangements should be regarded only as convenient configurations for checking the disturbance effects. The use of a control valve upstream of a flow-meter is not recommended. Shifts in calibration may result owing to the distortion of the velocity profile downstream of a control valve. The distortion is generally severe and is also a function of both the flow velocity and the valve opening. If a control valve has to be located in the vicinity of the flow-meter, it should be located downstream from the flow-meter where the effect on the calibration will be negligible.

5.2.3.3 Radius bends

Alternative pipe circuit configurations employing one or two upstream bends are shown in Table 4 and are described briefly hereafter. Selected pipe fitting testing arrangements should be agreed between the parties concerned, namely between the flow-meter manufacturer/supplier, the purchaser and the testing laboratory.

NOTE 5 Unless stated otherwise, the electrode plane is the plane normal to the pipe axis which contains the electrode pair.

a) One bend

A series of tests should be carried out on the flow-meter with a radius bend (having a dimension $r = 1,5$ DN, where r is the radius of the bend) mounted firstly immediately adjacent to the flow-meter upstream flange and secondly at 5 DN upstream from the traverse plane of the electrodes.

b) Two bends

A further series of tests should be undertaken in which two adjacent bends in mutually perpendicular planes are installed without separation, firstly immediately upstream of the flow-meter upstream flange and secondly at 5 DN upstream from the traverse plane of the electrodes.

For each testing arrangement the readings should be taken at each of the recommended points within the flow range of the meter. For all tests the orientation of the plane(s) of the bend(s) relative to the imaginary line joining the electrode centres diametrically should be recorded on the test data sheets, preferably in the form of a sketch showing the pertinent data.

NOTE 6 It should be realized that the costs of these tests will become very high for piping of large diameter. For testing meters with a diameter larger than DN 100, other and cheaper disturbances might be agreed upon between the user and the manufacturer; for example, annular or segmental obstructions can be used (see Figure 4).

5.2.4 Liquid pressure

The flow-meter output signal should, when practicable, be checked for the effects of changes in pressure of the flowing liquid over the full working pressure range. The maximum effect shall be stated as a percentage of the output span.

5.3 External influences

5.3.1 Electrical power supply aberrations

5.3.1.1 Main power variations

This test shall be carried out by measurement of the changes in the lower range value and the span caused by the adjustment of the power supply to the following values, load impedance being as specified in 5.1.

a) Voltage:

- a) nominal value;
- b) reference value plus 10 %, or the manufacturer's limit, if less;
- c) reference value minus 15 %, or the manufacturer's limit, if less.

b) Frequency:

- a) nominal value;
- b) reference value plus 2 % and reference value minus 10 %, or the manufacturer's limit, if narrower.

³⁾ Percentage positions of gate valve closure are defined in terms of the position of the valve blade leading edge, expressed as a percentage of the pipe diameter, and with the valve fully-open position as the datum.

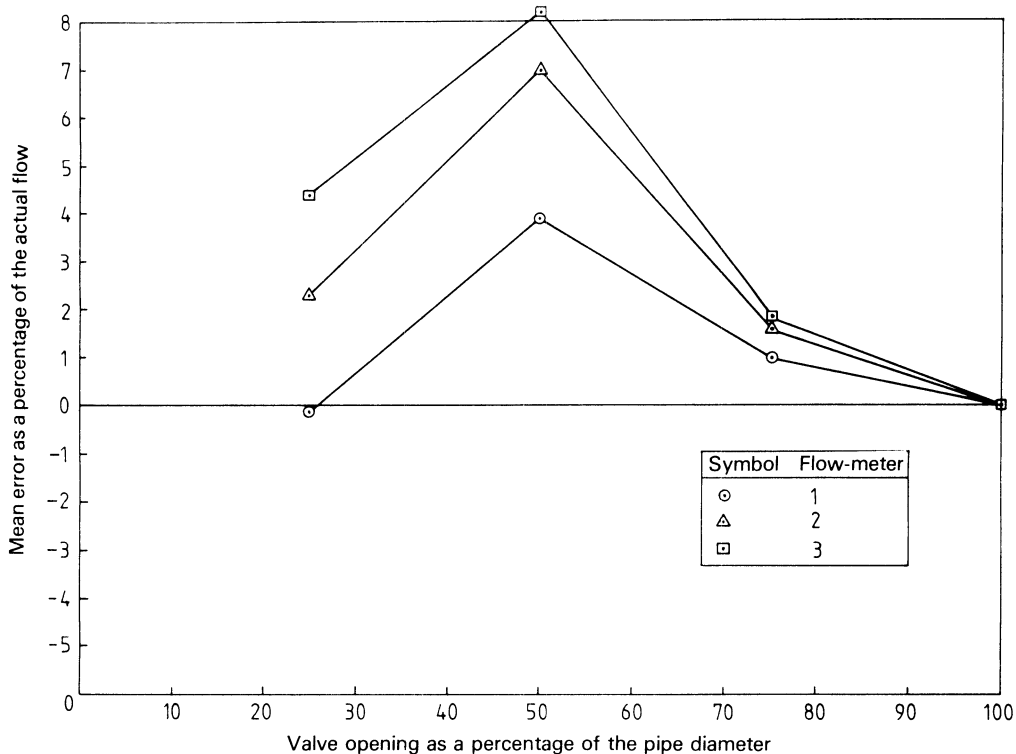



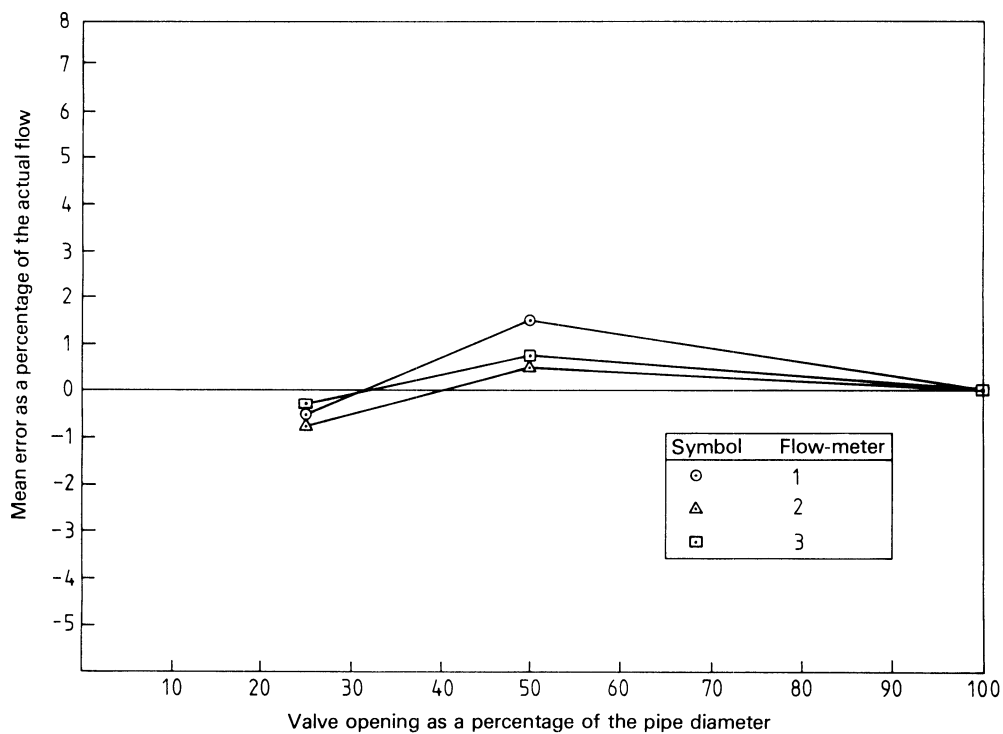







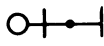
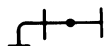
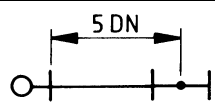
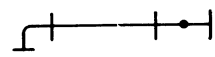
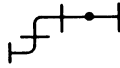
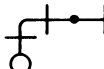
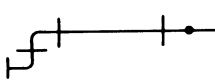
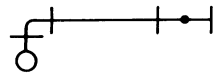
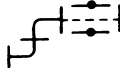
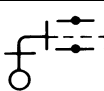
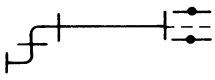

















a) Example for the valve positioned 1,5 DN upstream of the electrode plane, with the spindle at right-angles to the electrode axis



b) Example for the valve positioned 5,5 DN upstream of the electrode plane, with the spindle at right-angles to the electrode axis

Figure 3 — Examples showing the effect of an upstream gate valve on three electromagnetic meters of DN 500 (based on real data)

Table 4

Test arrangement	Description	Distance from outlet of pipe bend to electrode plane	General remarks	Explanatory diagram of circuit configuration ^a															
1	Single bend in the axial plane of the electrodes	Minimum																	
2	Single bend at right-angles to the axial electrode plane	Minimum																	
3	As test arrangement 1	5 DN																	
4	As test arrangement 2	5 DN																	
5	Two adjacent bends in the same plane	Minimum																	
6	Two adjacent bends in orthogonal planes	Minimum																	
7	As test arrangement 5	5 DN																	
8	As test arrangement 6	5 DN																	
9	As test arrangement 5	Minimum	Meter electrode plane at right-angles to that for arrangement 5																
10	As test arrangement 6	Minimum	Meter electrode plane at right-angles to that for arrangement 6																
11	As test arrangement 7	5 DN	Meter electrode plane at right-angles to that for arrangement 7																
12	As test arrangement 8	5 DN	Meter electrode plane at right-angles to that for arrangement 8																
^a Key: <table style="display: inline-table; vertical-align: middle;"> <tr> <td style="text-align: right;">Flow-meter</td> <td></td> <td style="text-align: left;">Bend</td> <td></td> <td></td> </tr> <tr> <td style="text-align: right;">Electrodes in the vertical plane</td> <td></td> <td></td> <td></td> <td></td> </tr> <tr> <td style="text-align: right;">Electrodes in the horizontal plane</td> <td></td> <td></td> <td></td> <td></td> </tr> </table>					Flow-meter		Bend			Electrodes in the vertical plane					Electrodes in the horizontal plane				
Flow-meter		Bend																	
Electrodes in the vertical plane																			
Electrodes in the horizontal plane																			

Under low-voltage/low-frequency conditions a check shall be made to establish that with the input near the upper range value, the output does not reach a limiting value below its upper range value. The effect shall be stated as a percentage of the output span.

5.3.1.2 Power supply interruptions

The purpose of this test is to determine the behaviour of the flow-meter on switching from the normal specified supply to a standby supply. The flow shall be held constant at 50 % of the span.

The power supply shall be interrupted for 5 ms, 20 ms, 100 ms, 200 ms and 500 ms for a d.c. supply, and for 1 cycle, 5 cycles, 10 cycles and 25 cycles at the crossover point for an a.c. supply.

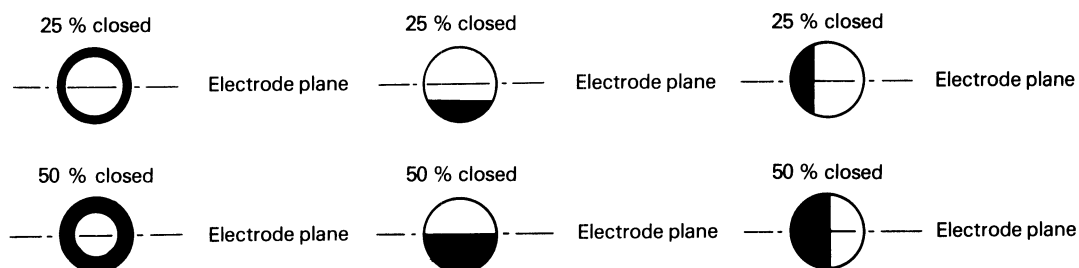

Figure 4 — Annular or segmental obstructions used to determine the effects of a disturbance in the inlet flow on the response of the flow-meter

The following values shall be recorded:

- the maximum transient negative and positive changes in output;
- the time taken for the output to reach 99 % of its steady-state value following reapplication of power;
- any permanent change in output.

In order to obtain a better estimate of the uncertainty, this test should be repeated ten times, the period of time between any two tests being at least equal to ten times the duration of the test.

5.3.1.3 Power supply distortion

A third-harmonic distortion of 5 % with variable phase shall be superimposed on the supply voltage. The maximum change in flow signal shall be determined and expressed as a percentage of the span.

5.3.2 Electrical interferences

During all the tests specified in this subclause, the flow shall be held constant at 50 % of the span.

5.3.2.1 Mains power supply transient overvoltages

Voltage spikes shall be superimposed on the mains supply. The spike energy shall be 0,1 J, and the spike amplitudes shall be 100 %, 200 % and 500 % overvoltage [percentage of nominal mains root-mean-square (r.m.s.) voltage]. The spike may be generated by capacitor discharge or by any means giving an equivalent waveform.

The power supply lines shall be protected by a suitable suppression filter, consisting at least of a choke of 500 μH capable of carrying the line current.

Two pulses of each amplitude phased to mains peak voltage shall be applied, or, alternatively, at least ten pulses randomly phased with respect to the mains supply shall be applied. Any transients or d.c. output changes appearing at the output of the instrument shall be recorded.

5.3.2.2 The influence of disturbing voltages

It may be necessary to adjust the secondary device so that both positive and negative changes can be detected. Figure 5 shows a typical circuit.

The results of each test shall be expressed as the ratio of the error to the value of the disturbance which caused the error.

5.3.2.2.1 Common mode — influence of an a.c. voltage between the earths of the primary and secondary device (artificially induced common-mode voltages) [Figure 6 a)]

A potential difference between the earth of the primary device and the earth of the secondary device will give rise to common-mode voltages on the measuring electrodes.

This potential difference will often be at the supply frequency. The following test is designed to measure the effect of mains frequency common-mode voltages on the performance of the electromagnetic flow-meter.

An a.c. voltage of 50 V (r.m.s.) at mains frequency shall be applied between the earth terminals of the primary and secondary devices. Two series of tests shall be performed, one with the disturbing voltage in phase with the mains and one with the disturbing voltage in quadrature with the mains.

During these tests it will be necessary to ensure that the primary device and the liquid therein are isolated from earth. The errors shall be stated as percentages of the output span.

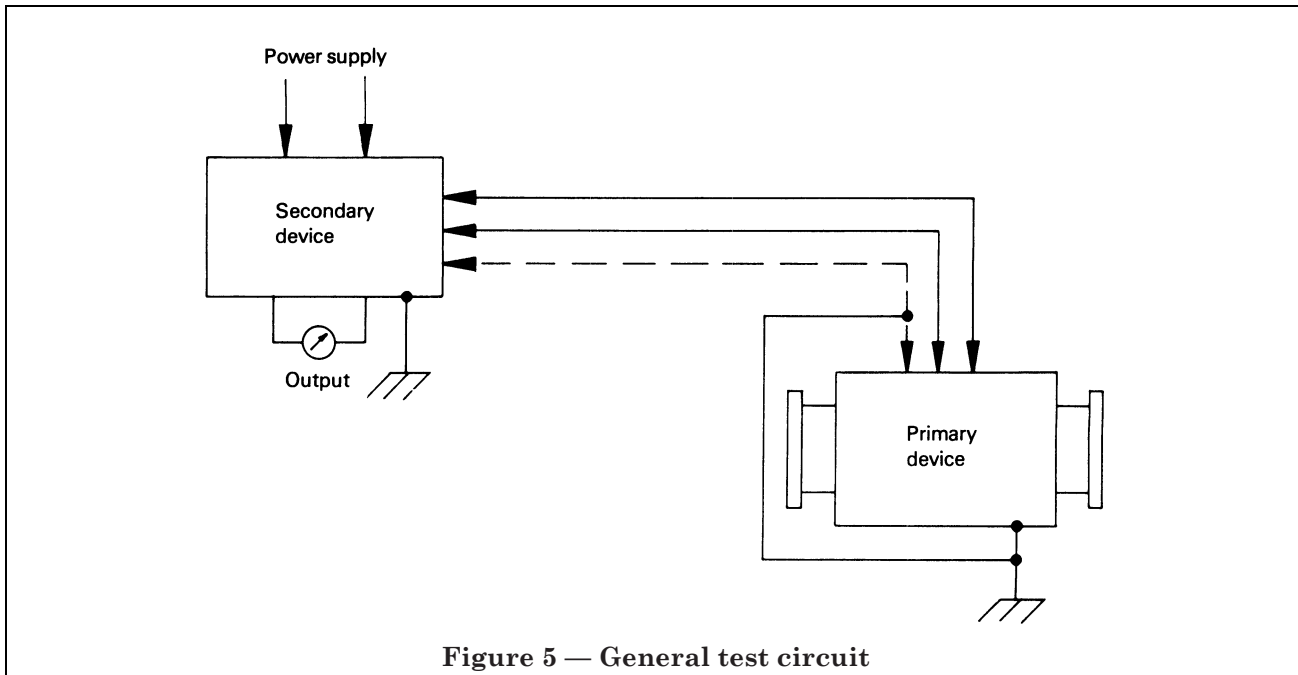

Figure 5 — General test circuit

5.3.2.2.2 Influence of an a.c. voltage between the earth and the mains supply (high neutral line voltage [Figure 6 b])

A potential difference adjustable between 0 V and 50 V (r.m.s.) at mains frequency shall be applied between the neutral and earth terminal of the primary device. The process is similar to that described in 5.3.2.2.1.

5.3.2.2.3 Influence of an a.c. voltage between the earth and the output terminals (Figure 7)

A potential difference adjustable between 0 V and 50 V (r.m.s.), or at a maximum voltage specified by the manufacturer, shall be applied between earth and the output terminals at mains frequency. Two series of tests shall be conducted with the disturbing voltage respectively in phase and in quadrature with the mains supply voltage. The error shall be stated as a percentage of the output span referring to the voltage.

NOTE 7 If there is no galvanic separation in the secondary device, the advice of the manufacturer should be sought.

5.3.2.2.4 Influence of currents flowing in an earthed connection between the primary and secondary devices (Figure 8)

In this case the process described in 5.3.2.2.1 is modified by replacing the disturbing voltage by a current adjustable between 0 A and 20 A. The errors shall be expressed as percentages of the output span referring to the current in amperes.

5.3.2.2.5 Influence of series-mode interferences (Figure 9)

These tests are only applicable to pulsed d.c. electromagnetic flow-meters or electromagnetic flow-meters operating at a frequency other than mains frequency. Since the flow-meters can to some extent reject series-mode interference at mains frequency, additional tests can be performed to measure the effect of series-mode signals at the supply frequency. There are several ways of performing these tests, most of which make use of a transformer to generate a small a.c. signal at mains frequency between the electrodes. The errors shall be expressed as percentages of the output span referred to the disturbing voltage in millivolts.

5.3.2.2.6 Influence of earthing

These tests are applicable only to secondary devices with electrical inputs and outputs isolated from earth.

The tests shall be carried out by measurement of the steady-state change in the lower range value and span caused by earthing each input and output terminal in turn.

Any transient changes shall be noted.

Care should be taken to eliminate any effect due to earthing of the test signal source.

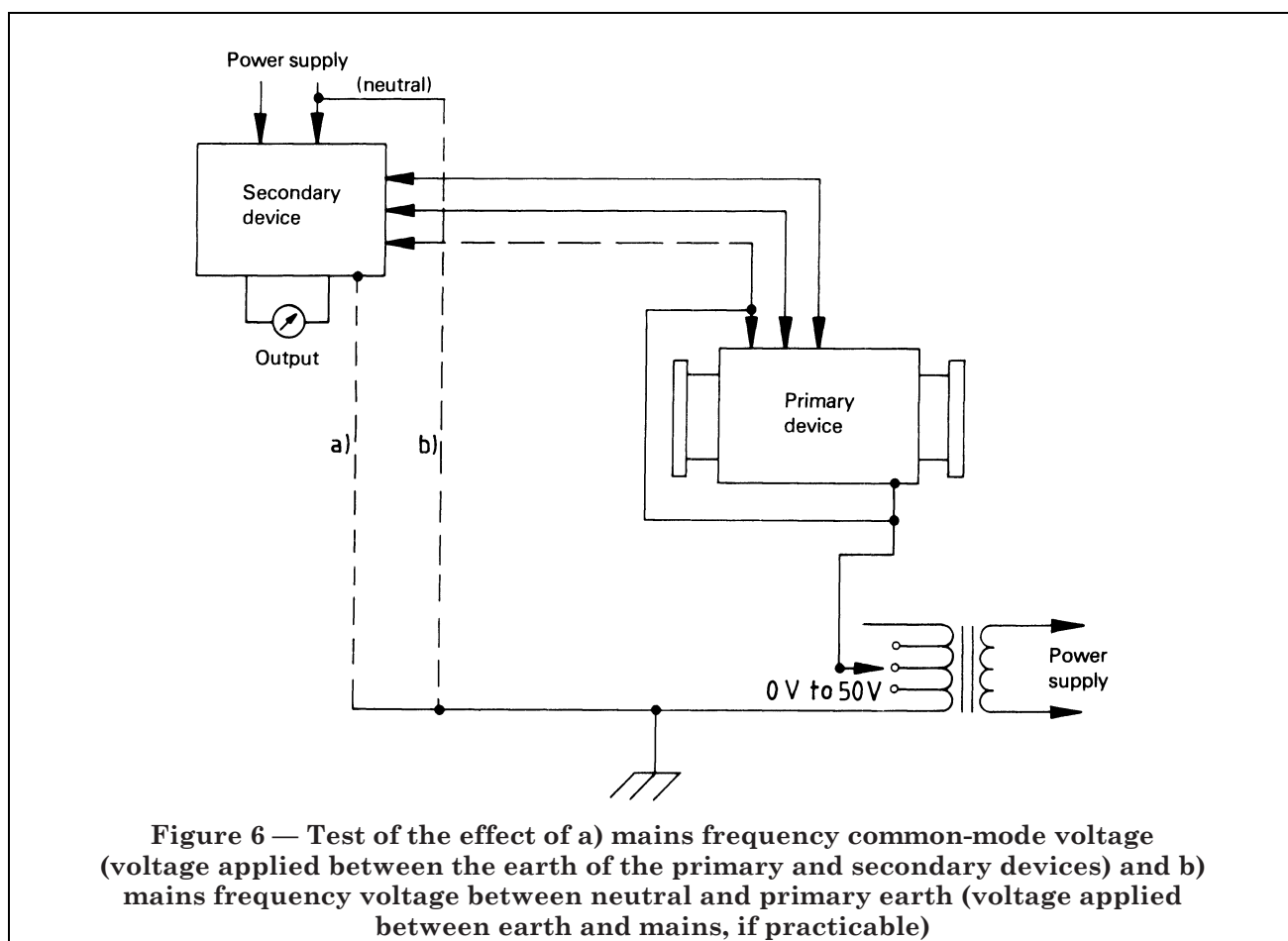

Figure 6 — Test of the effect of a) mains frequency common-mode voltage (voltage applied between the earth of the primary and secondary devices) and b) mains frequency voltage between neutral and primary earth (voltage applied between earth and mains, if practicable)

5.3.3 Ambient temperature

For those flow-meters of which the primary and secondary device are a unit, the test should, when practicable, be performed for the total unit. A minimum temperature-stabilization time of 4 h shall be applied to each temperature setting. The temperature range of this test should be determined by the operational conditions envisaged for the flow-meter system.

Remote secondary devices should be tested in accordance with IEC 770 as follows.

The changes in the value of the output signal shall be measured at the maximum and minimum operating temperatures specified by the manufacturer. If they are included in this operating range, the changes shall be measured at each of the following ambient temperatures:

- + 20 °C, + 40 °C, + 55 °C, 0 °C, – 10 °C,
- 25 °C, + 20 °C

The temperature shall be changed step by step in the order given, and without any adjustment of the flow-meter. A second temperature cycle, identical to the first, shall be performed without readjustment of the flow-meter.

The tolerance for each temperature is ± 2 °C. Sufficient time shall be allowed for stabilization of the temperature at all parts of the flow-meter. The effects shall be stated as percentages of the output span referring to the ambient temperature variation.

NOTE 8 The above temperatures relate to the ambient air temperature as stated. The process fluid should be at the nominal reference temperature.

5.3.4 Humidity (secondary device only)

This series of tests is based on the procedure described in IEC 68-2-3 and IEC 68-2-4.

Immediately after a further period of 24 h at ambient conditions, the error shall be determined at intervals of approximately 20 % span for upscale and downscale signals. Changes in error from those measured initially under ambient conditions shall be stated.

5.3.5 Mechanical vibration

A general procedure is described in IEC 68-2-6. However, it should be recognized that these tests may be very expensive or even impossible to carry out for large sizes of flow-meters. At the end of the test any change in calibration shall be stated.

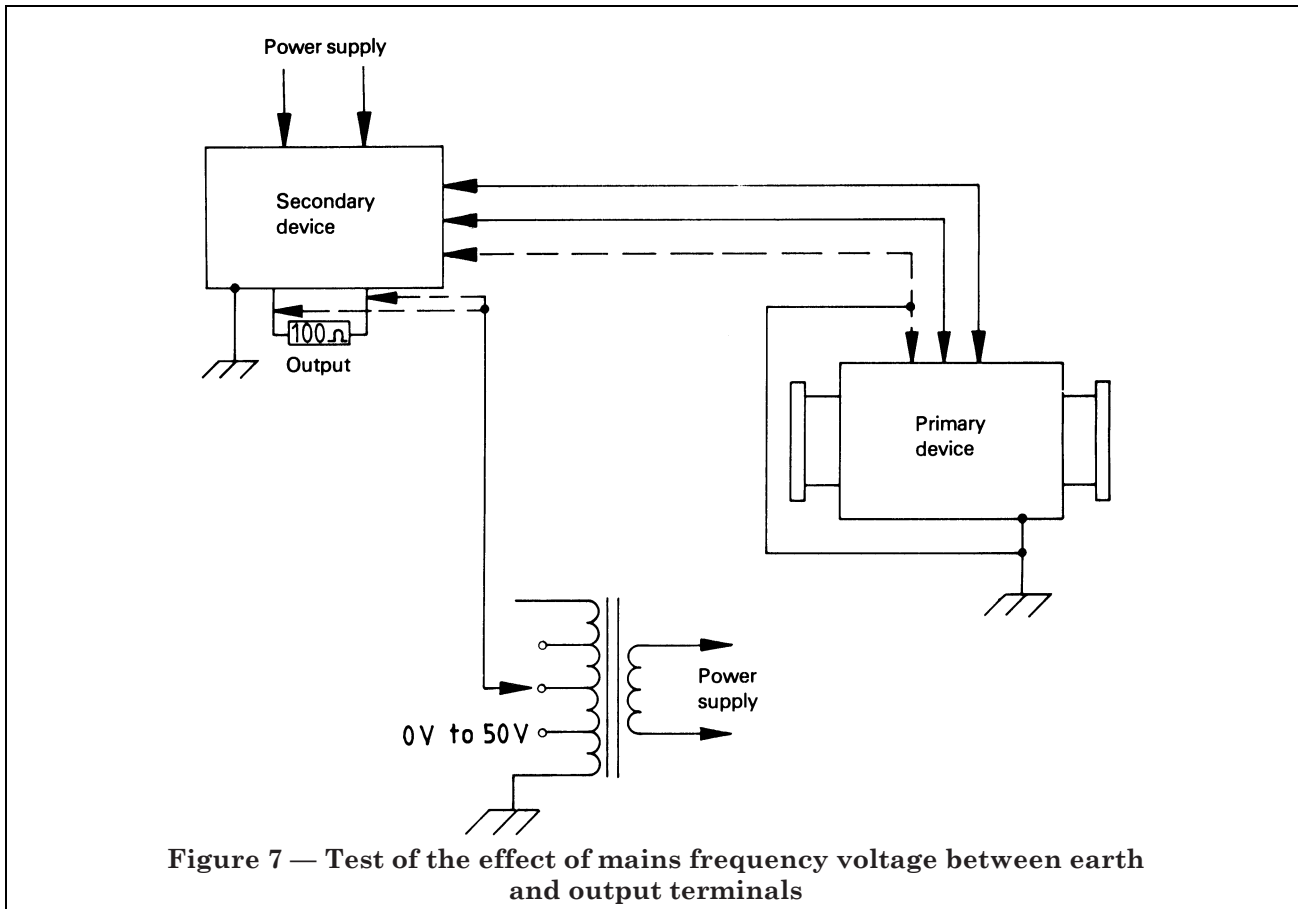

Figure 7 — Test of the effect of mains frequency voltage between earth and output terminals

5.3.6 Mechanical shock (secondary device only)

This test shall be carried out in accordance with IEC 68-2-27.

6 Tests for the evaluation of the effects of other influence quantities

6.1 Magnetic influence

If there is a possibility of influence from surrounding ferromagnetic materials or sources of magnetic field, a suitable test should be agreed with the manufacturer. The results of these tests shall be stated.

6.2 Output load impedance

This test shall be carried out by measurement of the change caused by variations in load impedance from the minimum to the maximum value specified by the manufacturer at the maximum test flow-rate. The output changes shall be expressed as percentages of the output span.

6.3 Long-term drift

The meter tube of the electromagnetic flow-meter shall be filled with water at ambient temperature. Before carrying out measurements, agitation of the water is recommended to ensure homogeneity. After being carefully adjusted, the electromagnetic flow-meter shall be switched off for 24 h. Then it shall be switched on and any change in the zero reading, after a suitable warm-up time, recorded and expressed as a percentage of the output span. Over the following four-week period the zero shall be rechecked every week and any change recorded.

6.4 Stray currents within the liquid

Stray currents flowing in the liquid inside an electromagnetic flow-meter may have an influence on the output of the flow-meter. Currents may be induced in the liquid using the system shown in Figure 10. Two series of tests shall be made with the disturbing voltage respectively in phase and in quadrature with the mains voltage. The errors shall be expressed as a percentage of the span per ampere.

6.5 Radio interference

Tests of the effect on the output of radio frequency interference shall be the subject of specific agreement between the manufacturer and the user.

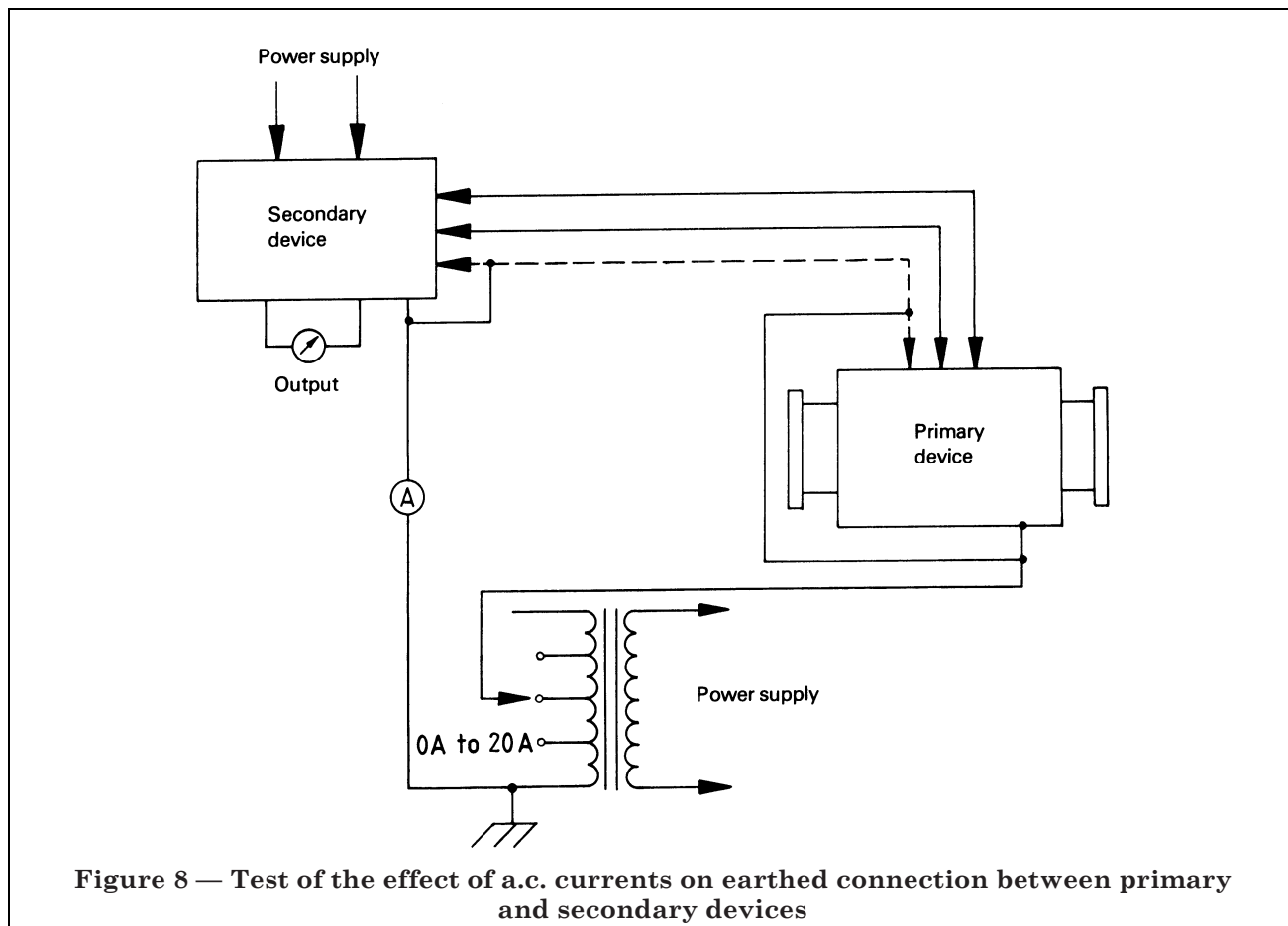

Figure 8 — Test of the effect of a.c. currents on earthed connection between primary and secondary devices

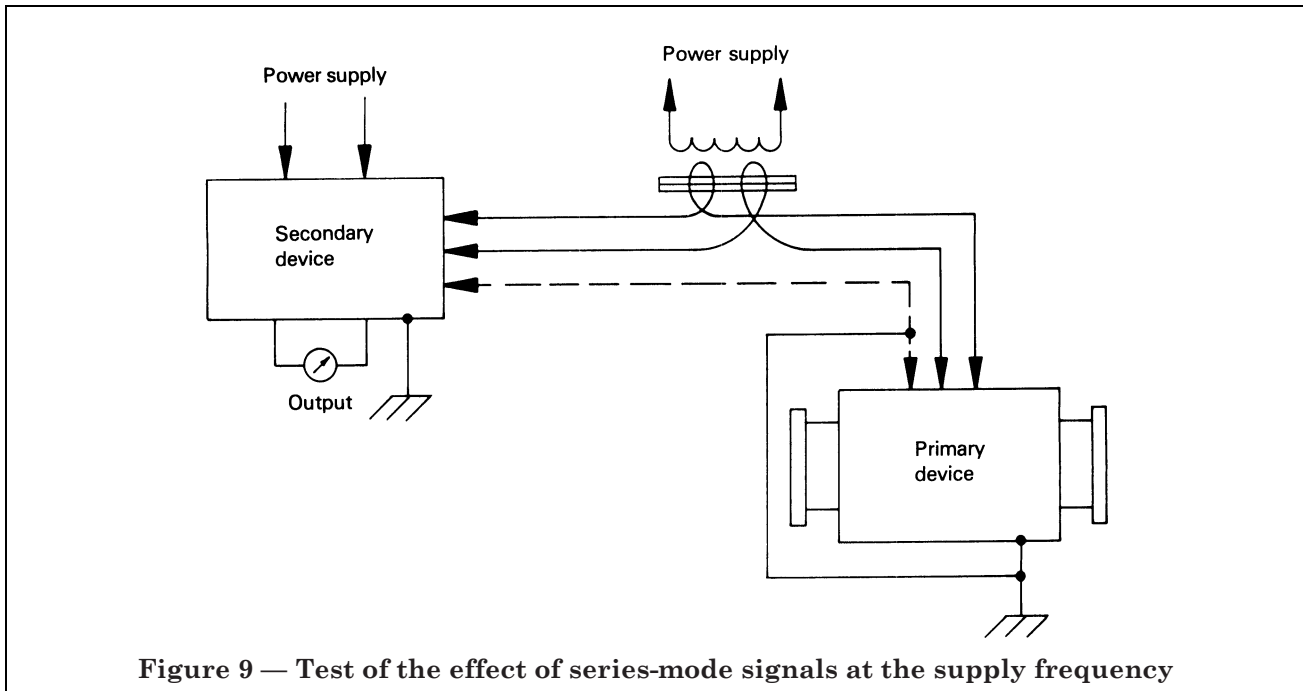

Figure 9 — Test of the effect of series-mode signals at the supply frequency

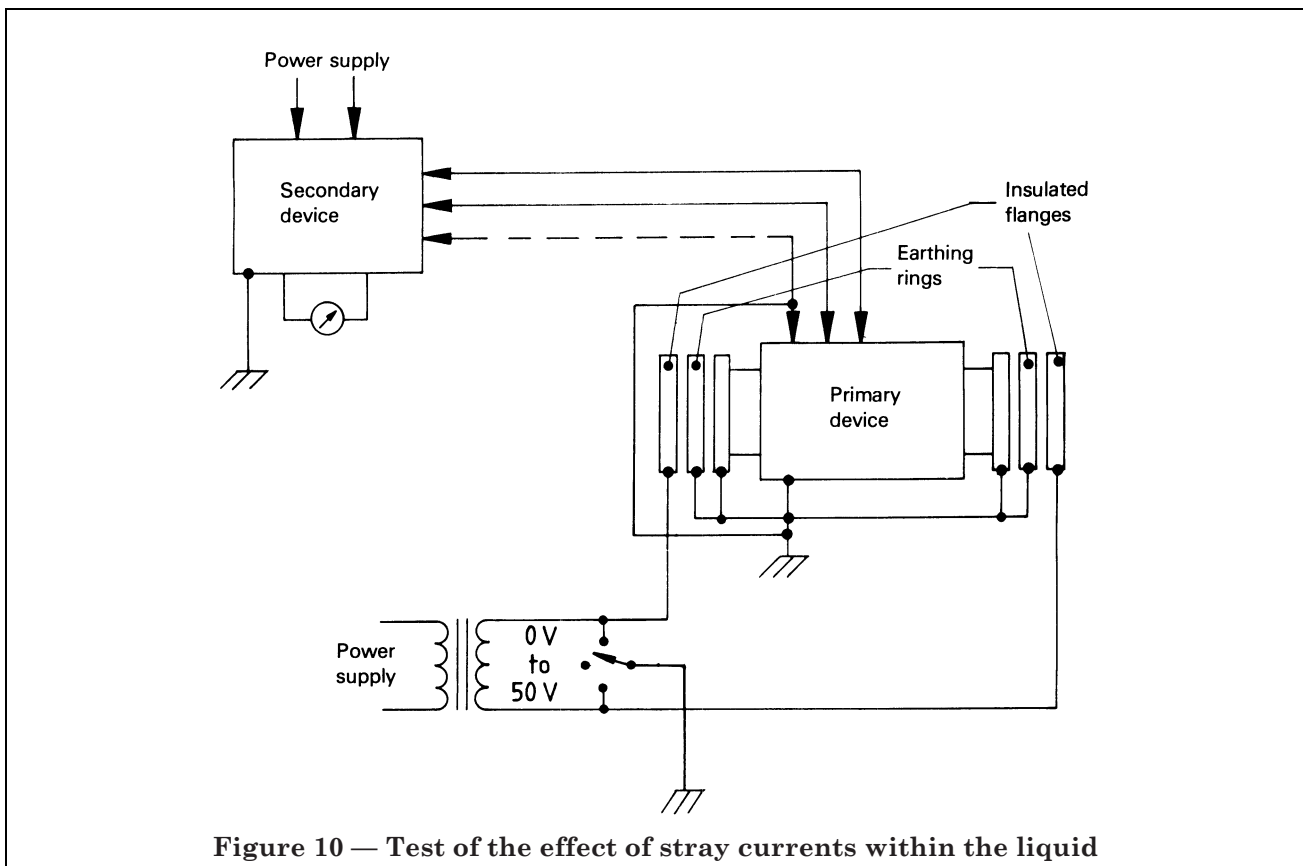

Figure 10 — Test of the effect of stray currents within the liquid

Annex A (informative)

Bibliography

- [1] IEC 160:1963, *Standard atmospheric conditions for test purposes.*
- [2] IEC 770:1984, *Methods of evaluating the performance of transmitters for use in industrial process control systems.*

Annex ZA (normative)**Normative references to international publications with their relevant European publications**

This European Standard incorporates by dated or undated reference, provisions from other publications. These normative references are cited at the appropriate places in the text and the publications are listed hereafter. For dated references, subsequent amendments to or revisions of any of these publications apply to this European Standard only when incorporated in it by amendment or revision. For undated references the latest edition of the publication referred to applies (including amendments).

Publication	Year	Title	EN/HD	Year
ISO 3966	1977	<i>Measurement of fluid flow in closed conduits — Velocity-area method using current-meters in full conduits and under regular flow conditions</i>	—	—
ISO 4006	1991	<i>Measurement of fluid flow in closed conduits — Vocabulary and symbols</i>	EN 24006	1993
ISO 4185	1980	<i>Measurement of liquid flow in closed conduits — Weighing method</i>	EN 24185	1993
ISO 5168	1978	<i>Measurement of fluid flow — Estimation of uncertainty of a flow-rate measurement</i>	—	—
ISO 6817	1992	<i>Measurement of conductive liquid flow in closed conduits — Method using electromagnetic flowmeters</i>	—	—
ISO 7066-1	1989	<i>Assessment of uncertainty in the calibration and use of flow measurement devices — Part 1: Linear calibration relationships</i>	—	—
ISO 7066-2	1988	<i>Assessment of uncertainty in the calibration and use of flow measurement devices — Part 2: Non-linear calibration relationships</i>	—	—
ISO 8316	1987	<i>Measurement of liquid flow in closed conduits — Method by collection of the liquid in a volumetric tank</i>	—	—
IEC 68-2-3	1969	<i>Basic environmental testing procedures — Test Ca: damp heat, steady state</i>	—	—
IEC 68-2-4	1960	<i>Basic environmental testing procedures — Test D: Accelerated damp heat</i>	—	—
IEC 68-2-6	1982	<i>Basic environmental testing procedures — Test Fc and guidance: Vibration (sinusoidal)</i>	—	—
IEC 68-2-27	1972	<i>Basic environmental testing procedures — Part 2: Tests. Test Ea and Guidance: Shock</i>	—	—

Publication(s) referred to

See national foreword.

BSI — British Standards Institution

BSI is the independent national body responsible for preparing British Standards. It presents the UK view on standards in Europe and at the international level. It is incorporated by Royal Charter.

Revisions

British Standards are updated by amendment or revision. Users of British Standards should make sure that they possess the latest amendments or editions.

It is the constant aim of BSI to improve the quality of our products and services. We would be grateful if anyone finding an inaccuracy or ambiguity while using this British Standard would inform the Secretary of the technical committee responsible, the identity of which can be found on the inside front cover. Tel: 020 8996 9000. Fax: 020 8996 7400.

BSI offers members an individual updating service called PLUS which ensures that subscribers automatically receive the latest editions of standards.

Buying standards

Orders for all BSI, international and foreign standards publications should be addressed to Customer Services. Tel: 020 8996 9001. Fax: 020 8996 7001.

In response to orders for international standards, it is BSI policy to supply the BSI implementation of those that have been published as British Standards, unless otherwise requested.

Information on standards

BSI provides a wide range of information on national, European and international standards through its Library and its Technical Help to Exporters Service. Various BSI electronic information services are also available which give details on all its products and services. Contact the Information Centre. Tel: 020 8996 7111. Fax: 020 8996 7048.

Subscribing members of BSI are kept up to date with standards developments and receive substantial discounts on the purchase price of standards. For details of these and other benefits contact Membership Administration. Tel: 020 8996 7002. Fax: 020 8996 7001.

Copyright

Copyright subsists in all BSI publications. BSI also holds the copyright, in the UK, of the publications of the international standardization bodies. Except as permitted under the Copyright, Designs and Patents Act 1988 no extract may be reproduced, stored in a retrieval system or transmitted in any form or by any means – electronic, photocopying, recording or otherwise – without prior written permission from BSI.

This does not preclude the free use, in the course of implementing the standard, of necessary details such as symbols, and size, type or grade designations. If these details are to be used for any other purpose than implementation then the prior written permission of BSI must be obtained.

If permission is granted, the terms may include royalty payments or a licensing agreement. Details and advice can be obtained from the Copyright Manager. Tel: 020 8996 7070.