

BS EN 28510-1:2014



BSI Standards Publication

Adhesives — Peel test for a flexible-bonded-to-rigid test specimen assembly

Part 1: 90° peel

bsi.

...making excellence a habit.™

National foreword

This British Standard is the UK implementation of EN 28510-1:2014. It supersedes BS EN 28510-1:1993 which is withdrawn.

The UK participation in its preparation was entrusted to Technical Committee PRI/52, Adhesives.

A list of organizations represented on this committee can be obtained on request to its secretary.

This publication does not purport to include all the necessary provisions of a contract. Users are responsible for its correct application.

© The British Standards Institution 2014. Published by BSI Standards Limited 2014

ISBN 978 0 580 82574 3

ICS 83.180

Compliance with a British Standard cannot confer immunity from legal obligations.

This British Standard was published under the authority of the Standards Policy and Strategy Committee on 30 April 2014.

Amendments issued since publication

Date	Text affected
------	---------------

English Version

**Adhesives - Peel test for a flexible-bonded-to-rigid test specimen
assembly - Part 1: 90° peel**Adhésifs - Essai de pelage pour un assemblage collé
flexible-sur-rigide - Partie 1: Pelage à 90°Klebstoffe - Schälprüfung für flexibel/starr geklebte Proben -
Teil 1: 90° Schälversuch

This European Standard was approved by CEN on 9 February 2014.

CEN members are bound to comply with the CEN/CENELEC Internal Regulations which stipulate the conditions for giving this European Standard the status of a national standard without any alteration. Up-to-date lists and bibliographical references concerning such national standards may be obtained on application to the CEN-CENELEC Management Centre or to any CEN member.

This European Standard exists in three official versions (English, French, German). A version in any other language made by translation under the responsibility of a CEN member into its own language and notified to the CEN-CENELEC Management Centre has the same status as the official versions.

CEN members are the national standards bodies of Austria, Belgium, Bulgaria, Croatia, Cyprus, Czech Republic, Denmark, Estonia, Finland, Former Yugoslav Republic of Macedonia, France, Germany, Greece, Hungary, Iceland, Ireland, Italy, Latvia, Lithuania, Luxembourg, Malta, Netherlands, Norway, Poland, Portugal, Romania, Slovakia, Slovenia, Spain, Sweden, Switzerland, Turkey and United Kingdom.

EUROPEAN COMMITTEE FOR STANDARDIZATION
COMITÉ EUROPÉEN DE NORMALISATION
EUROPÄISCHES KOMITEE FÜR NORMUNG**CEN-CENELEC Management Centre: Avenue Marnix 17, B-1000 Brussels**

Foreword

This document (EN 28510-1:2014) has been prepared by Technical Committee CEN/TC 193 “Adhesives”, the secretariat of which is held by AENOR.

This European Standard shall be given the status of a national standard, either by publication of an identical text or by endorsement, at the latest by October 2014 and conflicting national standards shall be withdrawn at the latest by October 2014.

Attention is drawn to the possibility that some of the elements of this document may be the subject of patent rights. CEN [and/or CENELEC] shall not be held responsible for identifying any or all such patent rights.

This document supersedes EN 28510-1:1993.

No technical provisions have been amended in this edition, however the references have been updated.

SAFETY STATEMENT — Persons using this document should be familiar with the normal laboratory practice, if applicable. This document does not purport to address all of the safety problems, if any, associated with its use. It is the responsibility of the user to establish appropriate safety and health practices and to ensure compliance with any regulatory conditions.

ENVIRONMENTAL STATEMENT — It is understood that some of the material permitted in this standard may have negative environmental impact. As technological advantages lead to acceptable alternatives for these materials, they will be eliminated from this standard to the extent possible.

At the end of the test, the user of the standard should take care to carry out an appropriate disposal of the wastes, according to local regulation.

According to the CEN-CENELEC Internal Regulations, the national standards organizations of the following countries are bound to implement this European Standard: Austria, Belgium, Bulgaria, Croatia, Cyprus, Czech Republic, Denmark, Estonia, Finland, Former Yugoslav Republic of Macedonia, France, Germany, Greece, Hungary, Iceland, Ireland, Italy, Latvia, Lithuania, Luxembourg, Malta, Netherlands, Norway, Poland, Portugal, Romania, Slovakia, Slovenia, Spain, Sweden, Switzerland, Turkey and the United Kingdom.

1 Scope

This part of EN 28510 specifies a 90° peel test for the determination, under specified conditions, of the peel resistance of a bonded assembly of two adherends where at least one adherend is flexible. If a normal tensile testing machine is used for the test, the peel angle will not be constant at exactly 90°. If a constant angle of exactly 90° is required, a roller peeling device is used (see 4.1).

The 90° peel test is particularly suitable for use with less flexible adherends for which a 180° peel test is not suitable because the adherends crack, break or delaminate.

A 180° peel test is described in EN ISO 8510-2.

2 Normative references

The following documents, in whole or in part, are normatively referenced in this document and are indispensable for its application. For dated references, only the edition cited applies. For undated references, the latest edition of the referenced document (including any amendments) applies.

EN 13887, *Structural Adhesives - Guidelines for surface preparation of metals and plastics prior to adhesive bonding*

EN ISO 291, *Plastics - Standard atmospheres for conditioning and testing (ISO 291)*

ISO 5725-2, *Accuracy (trueness and precision) of measurement methods and results — Part 2: Basic method for the determination of repeatability and reproducibility of a standard measurement method*

3 Principle

A bonded assembly of two adherends is prepared using the adhesive under test. The adherends are then pulled apart at a substantially steady rate, starting at the open end of the bond, in such a way that separation occurs progressively along the length of the bonded adherends. The force is applied approximately normal to the plane of the bond, through the separated part of the flexible adherend.

4 Apparatus

4.1 Tensile testing machine (incorporating a roller peeling device if a constant peel angle of exactly 90° is required), capable of supplying a tensile force with a constant rate of grip separation. The machine shall be equipped with a force-measuring system complete with an indicator and/or a recorder. The indicated force shall not differ from the true applied force by more than 2 %. The response time of the machine shall be short enough not to affect the accuracy with which the force applied at the time of rupture can be measured. The force at rupture of the specimen shall lie in the range between 10 % and 80 % of the full-scale reading.

4.2 Grips, one of which shall be suitable for firmly clamping the rigid adherend (see 5.1.2), while the other shall be suitable for holding the flexible adherend (see 5.1.3) as shown in Figure 1. The latter grip shall be self-aligning, so that the force will be exerted normal to the plane of the bond, and linked to the sensor of the tensile testing machine (4.1) by a wire of minimum length 600 mm.

5 Test specimens

5.1 Adherends

5.1.1 General

The adherends shall be thick enough to withstand the expected tensile force, and their dimensions shall be measured accurately and reported in full in the test report.

The recommended thicknesses of test specimens are: metals 1,5 mm; plastics 1,5 mm; wood 3 mm; compounded rubbers 2 mm. Other thicknesses agreed on between the purchaser and the supplier of the adhesive may be used.

5.1.2 Rigid adherend

The surface to be bonded shall have a width of $(25,0 \pm 0,5)$ mm and a minimum length of 150 mm.

The preferred material is mild steel, and, if this material is used, it is convenient to use a mild-steel T-piece having a stem of dimensions 75 mm × 25 mm × 10 mm.

If a material other than mild steel is used, a piece of this other material of width $(25,0 \pm 0,5)$ mm and minimum length 150 mm shall be bonded to the head of a T-piece of the kind described above. This allows the method to be used for testing an adhesive using two flexible adherends, one of which is bonded to the T-piece. The adhesive used for this purpose shall have adequate strength to ensure that this joint will not debond.

5.1.3 Flexible adherend

The flexible adherend shall be capable of being bent through an angle a little greater than 90° without irreversible dimensional change. The flexible adherend shall be of dimensions $(250,0 \pm 0,5)$ mm × $(25,0 \pm 0,5)$ mm.

5.2 Preparation of test specimens

The procedure used in preparing the test specimens shall be such as to minimize variations. The use of a pneumatic or hydraulic press, hand or power-operated, that can apply a pressure of up to 1 MPa, is recommended.

Surface treatments shall be in accordance with EN 13887, or, if not feasible, in accordance with the manufacturer's instructions. The adhesive under test shall be applied, allowed to set, and, if necessary, cured in accordance with the recommendations of the manufacturer of the adhesive.

A convenient method of obtaining a sharp adhesive boundary is to place a thin strip of material to which the adhesive does not adhere (anti-adhesive strip) at the end at which separation will commence of one of the adherends (see Figure 1).

If a rigid adherend other than the T-piece described in 5.1.2 is used, it shall be fastened to a T-piece of the kind described in 5.1.2 by a suitable method.

Bond the flexible adherend to the T-piece (or other rigid adherend) as shown in Figure 1, preferably using the method recommended by the manufacturer of the adhesive under test.

If a press is used to make the test specimens, it shall be capable of applying an even pressure over the entire bonded area and should preferably be fitted with a timer-controlled release mechanism. In order to provide a uniform distribution of pressure over the bonded area, the platens of the press shall be parallel. When this is impracticable, one platen shall be covered with a resilient pad. A 10 mm thick pad of rubber of Shore A hardness approximately 45 has been found to be satisfactory, using a press that applies a pressure of up to 700 kPa.

Determine the average thickness of the applied adhesive as accurately as practicable by weighing or another suitable technique.

5.3 Number of test specimens

A minimum of 5 specimens shall be tested.

6 Conditioning and testing atmosphere

The test specimens shall be conditioned and tested in one of the standard atmospheres specified in EN ISO 291.

7 Procedure

Place the stem of the T-piece in the grip at the non-sensing end of the test machine (see Figure 1). Position the test specimen in such a way that the centreline of the test machine coincides with the centre of the bonded area and is normal to the plane of the bond. Connect the free end of the flexible adherend to the wire by means of its grip. Set the machine in motion at a constant rate of grip separation.

The recommended rate of grip separation is (50 ± 5) mm/min.

Record the rate of grip separation. Also record the force as a function of grip separation, preferably autographically. Continue the test until a bonded length of at least 50 mm each side of the centre of the T-piece has separated. Note the type of failure, i.e. adhesive failure, cohesive failure or adherend failure.

8 Expression of results

For each specimen, determine from the curve of force versus grip separation the average peel force, in newtons, over a peel length of 50 mm each side of the centre of the T-piece. This may be done by drawing an estimated average line (see Figure 2) or by planimetry, or by another suitable means if a more accurate result is required. Record the maximum and minimum force in this range. Calculate the arithmetic mean of the average peel forces for all the specimens tested, as well as the arithmetic means of the maximum and minimum forces.

For the statistical treatment of results, see ISO 5725-2. If required, initial peak values occurring outside the test peel length may be recorded separately, but are excluded from the averaging procedure.

9 Precision

The precision of this test method is not known because inter-laboratory data are not available.

10 Test report

The test report shall include, at least, the following information:

- a) reference to this standard (EN 28510-1);
- b) complete identification of the adhesive tested, including type, source, manufacturer's code number, batch or lot number, form, etc.;
- c) complete description of the adherends, including dimensions, type of material and surface preparation;
- d) description of the bonding process, including method of application of adhesive, drying or pre-curing conditions and curing time (where applicable), and bonding temperature and pressure;
- e) average thickness of the adhesive layer after formation of the bond;
- f) complete description of the test specimens, including dimensions, construction and number tested;
- g) conditioning procedure prior to testing, and the atmosphere;
- h) rate of separation of the grips;

- i) method of determining the average peel force;
- j) maximum, minimum and average values of the peel force, in newtons, for each test specimen, and the arithmetic means of these values for all the test specimens;
- k) the type of failure for each test specimen, i.e. adhesive, cohesive or adherend;
- l) any deviation from the procedure specified that may have affected the results.

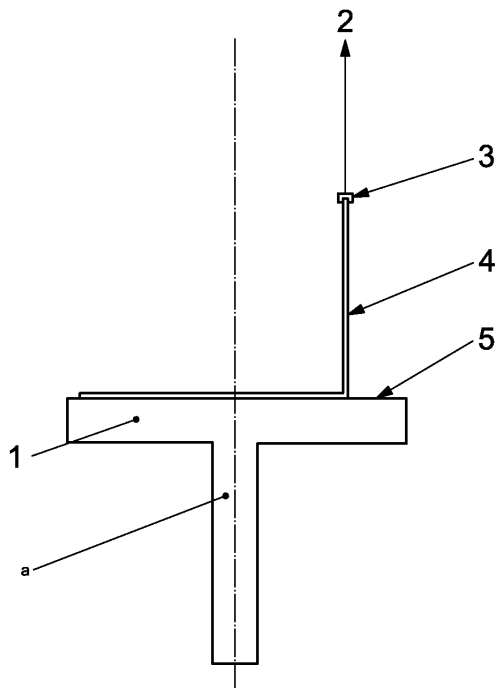

Key

- 1 rigid adherend
- 2 wire (minimum length 600 mm), connected to sensing element of tensile testing machine
- 3 grip
- 4 flexible adherend
- 5 anti-adhesive strip (see 5.2)
- a Connected to non-sensing grip of tensile testing machine

Figure 1 — Schematic diagram 90° peel test for a flexible-bonded-to-rigid assembly

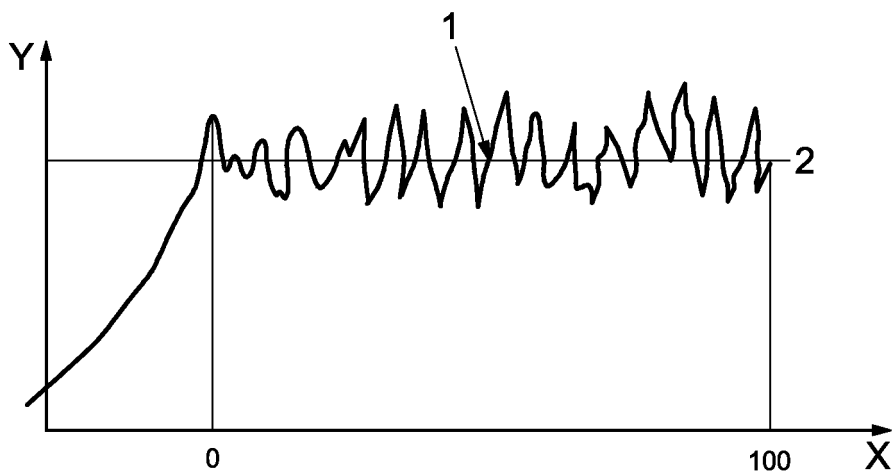

Key

- 1 centre of T-piece
- 2 estimated average value of peel force
- X Peel length, mm
- Y Force, N

Figure 2 — Typical peel force curve

Bibliography

- [1] EN ISO 527, *Plastics — Determination of tensile properties (ISO 527)*
- [2] EN ISO 8510-2, *Adhesives - Peel test for a flexible-bonded-to-rigid test specimen assembly - Part 2: 180 degree peel (ISO 8510-2:2006)*

British Standards Institution (BSI)

BSI is the national body responsible for preparing British Standards and other standards-related publications, information and services.

BSI is incorporated by Royal Charter. British Standards and other standardization products are published by BSI Standards Limited.

About us

We bring together business, industry, government, consumers, innovators and others to shape their combined experience and expertise into standards-based solutions.

The knowledge embodied in our standards has been carefully assembled in a dependable format and refined through our open consultation process. Organizations of all sizes and across all sectors choose standards to help them achieve their goals.

Information on standards

We can provide you with the knowledge that your organization needs to succeed. Find out more about British Standards by visiting our website at bsigroup.com/standards or contacting our Customer Services team or Knowledge Centre.

Buying standards

You can buy and download PDF versions of BSI publications, including British and adopted European and international standards, through our website at bsigroup.com/shop, where hard copies can also be purchased.

If you need international and foreign standards from other Standards Development Organizations, hard copies can be ordered from our Customer Services team.

Subscriptions

Our range of subscription services are designed to make using standards easier for you. For further information on our subscription products go to bsigroup.com/subscriptions.

With **British Standards Online (BSOL)** you'll have instant access to over 55,000 British and adopted European and international standards from your desktop. It's available 24/7 and is refreshed daily so you'll always be up to date.

You can keep in touch with standards developments and receive substantial discounts on the purchase price of standards, both in single copy and subscription format, by becoming a **BSI Subscribing Member**.

PLUS is an updating service exclusive to BSI Subscribing Members. You will automatically receive the latest hard copy of your standards when they're revised or replaced.

To find out more about becoming a BSI Subscribing Member and the benefits of membership, please visit bsigroup.com/shop.

With a **Multi-User Network Licence (MUNL)** you are able to host standards publications on your intranet. Licences can cover as few or as many users as you wish. With updates supplied as soon as they're available, you can be sure your documentation is current. For further information, email bsmusales@bsigroup.com.

Revisions

Our British Standards and other publications are updated by amendment or revision.

We continually improve the quality of our products and services to benefit your business. If you find an inaccuracy or ambiguity within a British Standard or other BSI publication please inform the Knowledge Centre.

Copyright

All the data, software and documentation set out in all British Standards and other BSI publications are the property of and copyrighted by BSI, or some person or entity that owns copyright in the information used (such as the international standardization bodies) and has formally licensed such information to BSI for commercial publication and use. Except as permitted under the Copyright, Designs and Patents Act 1988 no extract may be reproduced, stored in a retrieval system or transmitted in any form or by any means – electronic, photocopying, recording or otherwise – without prior written permission from BSI. Details and advice can be obtained from the Copyright & Licensing Department.

Useful Contacts:

Customer Services

Tel: +44 845 086 9001

Email (orders): orders@bsigroup.com

Email (enquiries): cservices@bsigroup.com

Subscriptions

Tel: +44 845 086 9001

Email: subscriptions@bsigroup.com

Knowledge Centre

Tel: +44 20 8996 7004

Email: knowledgecentre@bsigroup.com

Copyright & Licensing

Tel: +44 20 8996 7070

Email: copyright@bsigroup.com

BSI Group Headquarters

389 Chiswick High Road London W4 4AL UK



...making excellence a habit.™