



BSI Standards Publication

**Reaction to fire tests
for building products —
Determination of a building
product's propensity
to undergo continuous
smouldering**

National foreword

This British Standard is the UK implementation of EN 16733:2016.

The UK participation in its preparation was entrusted to Technical Committee FSH/21/-/17, Reaction to fire tests - European fire test methods including ignitability tests.

A list of organizations represented on this committee can be obtained on request to its secretary.

This publication does not purport to include all the necessary provisions of a contract. Users are responsible for its correct application.

© The British Standards Institution 2016.

Published by BSI Standards Limited 2016

ISBN 978 0 580 83888 0

ICS 13.220.50

Compliance with a British Standard cannot confer immunity from legal obligations.

This British Standard was published under the authority of the Standards Policy and Strategy Committee on 31 May 2016.

Amendments/corrigenda issued since publication

Date	Text affected
------	---------------

EUROPEAN STANDARD

EN 16733

NORME EUROPÉENNE

EUROPÄISCHE NORM

May 2016

ICS 13.220.50

English Version

Reaction to fire tests for building products - Determination of a building product's propensity to undergo continuous smouldering

Essais de réaction au feu pour les produits de construction - Détermination de la propension d'un produit de construction à subir un feu couvant continu

Prüfungen zum Brandverhalten von Bauprodukten - Bestimmung der Neigung eines Bauprodukts zum kontinuierlichen Schwelen

This European Standard was approved by CEN on 12 February 2016.

CEN members are bound to comply with the CEN/CENELEC Internal Regulations which stipulate the conditions for giving this European Standard the status of a national standard without any alteration. Up-to-date lists and bibliographical references concerning such national standards may be obtained on application to the CEN-CENELEC Management Centre or to any CEN member.

This European Standard exists in three official versions (English, French, German). A version in any other language made by translation under the responsibility of a CEN member into its own language and notified to the CEN-CENELEC Management Centre has the same status as the official versions.

CEN members are the national standards bodies of Austria, Belgium, Bulgaria, Croatia, Cyprus, Czech Republic, Denmark, Estonia, Finland, Former Yugoslav Republic of Macedonia, France, Germany, Greece, Hungary, Iceland, Ireland, Italy, Latvia, Lithuania, Luxembourg, Malta, Netherlands, Norway, Poland, Portugal, Romania, Slovakia, Slovenia, Spain, Sweden, Switzerland, Turkey and United Kingdom.



EUROPEAN COMMITTEE FOR STANDARDIZATION
COMITÉ EUROPÉEN DE NORMALISATION
EUROPÄISCHES KOMITEE FÜR NORMUNG

CEN-CENELEC Management Centre: Avenue Marnix 17, B-1000 Brussels

Contents		Page
European foreword		3
Introduction		4
1	Scope	5
2	Normative references	5
3	Terms and definitions	5
4	Principle	6
5	Test apparatus	6
5.1	Main apparatus	6
5.1.1	Test specimen holder	7
5.1.2	Wire mesh box	7
5.1.3	Propane burner	7
5.1.4	Thermocouples in the test specimen	7
5.1.5	Recording device	7
5.2	Additional equipment	8
5.2.1	Flowmeter	8
5.2.2	Timing device	8
5.2.3	Anemometer	8
5.2.4	Fire extinguishing board	8
6	Test specimens	8
6.1	General	8
6.2	Dimensions and number of test specimens	8
6.3	Loose fill materials	8
7	Conditioning of specimens	8
8	Test procedure	9
9	Termination of test	9
10	Expression of results	10
11	Performance criteria and declaration	10
12	Direct and extended application of test results	10
13	Test report	11
Annex A (informative) Precision of the method		19
A.1	General	19
A.2	Conclusions	20
Bibliography		21

European foreword

This document (EN 16733:2016) has been prepared by Technical Committee CEN/TC 127 “Fire safety in buildings”, the secretariat of which is held by BSI.

This European Standard shall be given the status of a national standard, either by publication of an identical text or by endorsement, at the latest by November 2016, and conflicting national standards shall be withdrawn at the latest by February 2018.

Attention is drawn to the possibility that some of the elements of this document may be the subject of patent rights. CEN [and/or CENELEC] shall not be held responsible for identifying any or all such patent rights.

This document has been prepared under a mandate given to CEN by the European Commission and the European Free Trade Association.

This standard is produced in response to the EC mandate M/385. CEN/TC 127 was requested to develop this test method to determine possible glowing combustion behaviour in building products. This test method forms part of the present EC classification system for the reaction to fire.

Task Group 6 of CEN TC 127/WG4 was created to develop this test method. In the early stages of its development, it was found that the term ‘glowing combustion’ as defined in EN ISO 13943 does not completely characterize the specific combustion behaviour of a building product. In particular, the increase of temperature which is considered as typical for the process of smouldering is not considered in the EN ISO 13943 definition. Therefore the task group made a clarification and changed the term glowing combustion to smouldering combustion. Smouldering is defined in this standard as ‘combustion of a material without flame and with or without visible light’. This includes glowing combustion.

According to the CEN/CENELEC Internal Regulations, the national standards organizations of the following countries are bound to implement this European Standard: Austria, Belgium, Bulgaria, Croatia, Cyprus, Czech Republic, Denmark, Estonia, Finland, Former Yugoslav Republic of Macedonia, France, Germany, Greece, Hungary, Iceland, Ireland, Italy, Latvia, Lithuania, Luxembourg, Malta, Netherlands, Norway, Poland, Portugal, Romania, Slovakia, Slovenia, Spain, Sweden, Switzerland, Turkey and the United Kingdom.

Introduction

This test method has been developed considering methods NT FIRE 002 and NT FIRE 035 and standards BS 5803-4 and Önorm B 3800. It specifies a test for determining the propensity of products to smoulder continuously when tested in a vertical orientation. The method does not impose a mechanically influenced airflow through the test specimens since this would not represent most end-use conditions.

Safety warning

The attention of all persons concerned with managing and carrying out this test is drawn to the fact that fire testing may be hazardous and that there is a possibility that toxic and/or harmful smoke and gases may be evolved during the test. Operational hazards may also arise during the testing of specimens and the disposal of test residues.

An assessment of all potential hazards and risks to health should be made and safety precautions should be identified and provided. Written safety instructions should be issued. Appropriate training should be given to relevant personnel. Laboratory personnel should ensure that they follow written safety instructions at all times.

Adequate means of extinguishing the specimen should be provided, bearing in mind that some specimens may produce severe flaming during the test. A hand water spray or an inert gas suppression system e.g. compressed nitrogen which can be directed to the burning area should be available together with other means, such as fire extinguishers etc.

In some cases, smouldering may be difficult to extinguish completely and immersion in water may be necessary.

1 Scope

This European Standard specifies a test method to determine the propensity (ability) of a building product to smoulder continuously when exposed to an open flame under the influence of natural convective airflow.

It is intended for all building products classified according to EN 13501-1. Details as to how the products is mounted and fixed for this test are given in the relevant product standards. The field of application of the test results is defined in the product standards.

2 Normative references

The following documents, in whole or in part, are normatively referenced in this document and are indispensable for its application. For dated references, only the edition cited applies. For undated references, the latest edition of the referenced document (including any amendments) applies.

EN 13238 *Reaction to fire tests for building products — Conditioning procedures and general rules for selection of substrates*

EN 60584-1 *Thermocouples — Part 1: EMF specifications and tolerances (IEC 60584-1)*

EN ISO 13943, *Fire safety — Vocabulary (ISO 13943)*

3 Terms and definitions

For the purposes of this document, the terms and definitions given in EN ISO 13943 and the following apply.

3.1

product

material, composite or assembly about which information is required

3.2

material

basic single substance or a uniformly dispersed mixture of substances e.g. metal, stone, wood, concrete, mineral wool

3.3

composite

combination of materials which are generally recognised as discrete entities e.g. coated or laminated materials

3.4

assembly

fabrication of materials and/or composites e.g. sandwich panels

3.5

exposed surface

surface of the product which is subjected to the heating conditions of the test

3.6

test specimen

representative piece of the sample (prepared for testing in accordance with instruction)

3.7 smouldering

combustion of a material without flame and with or without visible light. This includes glowing combustion

Note 1 to entry: Smouldering is generally evidenced by an increase in temperature and/or by the presence of effluents.

3.8 progressive smouldering

self-propagating exothermic oxidation that is not accompanied by flaming combustion

Note 1 to entry: It can be accompanied by glowing.

3.9 sustained flaming

persistence of flaming for a period greater than 10 s

3.10 flame spread

propagation of flame away from the source of sustained flaming

3.11 glowing combustion

combustion of a material in the solid phase without flame but with emission of light from the combustion zone

4 Principle

One test specimen is vertically mounted and exposed to constant heat from a propane gas burner with its flame impinging on the specimen surface. Smouldering is detected by measuring temperatures by using thermocouples installed at defined distances within the vertical test specimen and the observation of sustained flaming following re-ignition.

5 Test apparatus

5.1 Main apparatus

NOTE All dimensions given in the following description are nominal unless tolerances are specified.

The main apparatus is shown in Figures 1, 2 and 3. The apparatus includes:

- specimen holder;
- propane burner;
- wire mesh box (Figure 4);
- six thermocouples inside the specimen connected to a recording device (Figure 5);
- specimen holder frame to hold flexible or thin products in place (Figure 6).

5.1.1 Test specimen holder

The specimen mounting frame shall hold the specimen 50 mm above the test floor. This shall be accomplished by the use of two spacers or supporting devices, maximum 50 mm high x 50 mm wide and 100 mm long placed at the outer edge of the specimen, mounted on the floor upon which the bottom edge of the test specimen shall be located. (See Figures 1, 2 and 3).

The test specimen shall not be continuously covered from top to bottom on the vertical side edges. The maximum cover on the vertical edges of the specimens shall consist of two clamps on each side each not more than 40 mm in height. Neither the top nor the bottom edges of the specimen shall be covered in any way.

For thin or flexible test specimens, a planar surface shall be maintained. This can be achieved either by clamping between the sections of flat steel frame, 800 mm × 300 mm, with a frame width of 10 mm and a thickness of 3 mm or by using a single frame with pins on all four edges upon which the specimen shall be supported. (See Figure 6).

5.1.2 Wire mesh box

For loose fill material the specimen holder shown in Figure 4 shall be used. The specimen holder shall consist of a steel framed wire mesh box, 800 mm high, 300 mm wide and 100 mm deep. The top of the wire mesh box is open and remains open for the test. The wire mesh shall be zinc-coated with a width of mesh 9 mm ± 1 mm and a wire size 1 mm ± 0,2 mm. (See Figure 4).

5.1.3 Propane burner

The burner shall be of the Teclu type (see Figure 7). The nominal inner diameter of the burner is 10,3 mm and the nominal inner diameter of the outer tube is 14,95 mm. The gas nozzle shall have an inner diameter of 0,5 mm ± 0,1 mm. The straight part of the burner tube shall have a length of 100 mm ± 10 mm, the conical part shall have a length of 35 mm ± 3 mm. The lower part of the opening of the conical part shall have an inner diameter of 30 mm ± 5 mm.

Propane having a purity of at least 95 % shall be used.

The air supply to the burner shall be fully open. The propane flow rate of the burner shall be 100 g/h ± 5 g/h. (0,85 l/min ± 0,05 l/min).

5.1.4 Thermocouples in the test specimen

Six sheathed type K thermocouples according to EN 60584-1 with outer diameter of 1,5 mm shall be positioned within the test specimen. The thermocouples shall be located in the positions as shown in Figure 5.

The tips of the thermocouples shall be positioned on the centre line of the test specimen at 100 mm intervals measured vertically from the centre line of the burner (see Figure 5). These thermocouples shall be within the test specimen at half the actual specimen thickness. The thermocouples shall be mounted from the reverse face of the test specimen.

The thermocouples shall be supported by a framework at the rear of the test specimen, 40 mm x 80 mm x 855 mm. This framework shall be positioned at least 50 mm from the reverse face of the test specimen.

5.1.5 Recording device

A recording device shall be used to record the temperatures during the test. The recording device shall be capable of recording data at least every 30 s.

5.2 Additional equipment

5.2.1 Flowmeter

The flow of propane to the burner shall be controlled and measured with a flowmeter. This shall have an accuracy of $\pm 3\%$.

5.2.2 Timing device

This shall have an accuracy of ± 1 s per h.

5.2.3 Anemometer

A hot wire anemometer with an accuracy of $0,1\text{ ms}^{-1}$.

5.2.4 Fire extinguishing board

A calcium silicate board (suggested size $850 \times 320 \times 10$ mm) shall be used to extinguish any flaming established after removal of the burner. The board shall be placed over the face of the specimen to extinguish any flaming.

6 Test specimens

6.1 General

The test specimens shall be cut from a sample which is representative of the product to be tested.

6.2 Dimensions and number of test specimens

6.2.1 At least two specimens shall be cut for test.

6.2.2 The test specimens shall be rectangular with the dimensions (800 ± 3) mm \times (300 ± 3) mm.

6.2.3 The test specimen shall be tested at its end-use thickness up to a maximum of 100 mm. If the test specimen is symmetrical reduce the thickness from the reverse side to 100 mm. If the specimen is unsymmetrical then the thickness shall be reduced from the reverse side however both sides of the specimen shall be tested.

A product with directional properties shall be tested in both directions. In this case test one specimen in each direction and complete the test using the worst orientation.

6.2.4 The test specimen shall be positioned in the test specimen holder.

6.2.5 If the material under test is too small to obtain a test specimen in the correct dimensions, the test specimen may be produced from several small pieces. However, the portion exposed to the gas flame shall be in one piece. The dimensions of the pieces making up such a test specimen shall be specified in the test report.

6.3 Loose fill materials

Loose fill products shall be fitted into a wire mesh box (see Figure 4) in such a way that the density specified by the manufacturer is achieved (see 5.1.2).

7 Conditioning of specimens

Test specimens shall be conditioned as described in EN 13238.

8 Test procedure

8.1 The test shall be carried out in an environment essentially free from air currents. The room temperature shall be $20\text{ }^{\circ}\text{C} \pm 10\text{ }^{\circ}\text{C}$ and the air velocity measured using the hot wire anemometer according to 5.2.3 at 100 mm and 600 mm above the test floor and 100 mm away from the front and rear edges of the test pieces shall not exceed $0,2\text{ ms}^{-1}$ in any direction. The effluent gases shall be extracted without causing any draught near the test specimen to exceed $0,2\text{ ms}^{-1}$ in any direction.

8.2 The test specimen shall be positioned in the specimen holder and six thermocouples shall be positioned within the test specimen (see 5.1.4 and Figure 5).

8.3 The burner shall be ignited and allowed to stabilize for at least 2 min.

8.4 Start the data logger or chart recorder.

8.5 The test shall commence when the burner is placed in position. The burner shall be placed centrally with the axis horizontal and perpendicular to the surface of the test specimen and 100 mm above the bottom edge of the specimen. The distance from the front surface of the burner head to the exposed surface of the specimen shall be $60\text{ mm} \pm 2\text{ mm}$. (See Figure 1).

At the same time as the burner is positioned, the timing device shall be started.

8.6 Expose the specimen to the flame for 15 min.

8.6.1 If the product ignites whilst the burner is being applied, monitor the burning. If the specimen needs to be extinguished due to flame reaching 200 mm above the top of the specimen for a period of more than 30 s, this test method is not suitable for the product being evaluated.

8.6.2 After 15 min the burner shall be removed. The fire extinguishing board shall be applied to the face of the specimen for a period of 20 s.

If the specimen ignites again within 60 s after removal of the fire extinguishing board, apply the board again for a further 40 s. If the specimen again ignites after removal of the fire extinguishing board, the test shall be stopped. This test method shall be deemed to be not suitable for the product being evaluated.

This process has to be done carefully to avoid any interference in the test specimen behaviour.

8.7 If the specimen ignites within 5 min after removal of the burner the fire extinguishing board shall be reapplied for a further 20 s.

8.8 The behaviour of the test pieces during the test and their condition after the test shall be observed. This includes sustained flaming, distance of flame spread, melting, spalling, charring, expansion, shrinkage, delamination or any other behaviour.

8.9 At least two test specimens shall be tested for a formal test. Further specimens shall be tested where the product has directional properties (see 6.2.3).

8.10 The apparatus shall be cooled to ambient temperature between successive tests.

9 Termination of test

9.1 The test shall be terminated:

a) after 6 h or

- b) after all thermocouples have shown no further increase in temperature for at least 60 min and all recorded temperatures are below 50 °C,

whichever is the shorter.

9.2 The test should also be terminated if any of the conditions defined in Clause 10 of this standard are deemed to have occurred.

10 Expression of results

Continuous smouldering has occurred if any one or more of the following has been observed:

- a) sustained flaming at the top or either vertical side of the specimen has occurred which has not been caused by a visible spread of flame on the surface of the specimen;
- b) re-ignition of the specimen has occurred on any surface or edge 5 min or more after removal of the burner and after all sustained flaming on the surface of the specimen has ceased;
- c) after removal of the burner flame, thermocouple 6 (see Figure 5) registers a temperature rise of more than 250 °C;
- d) after the maximum test duration of 6 h any of the thermocouples registers more than 50 °C or increasing temperatures for at least 60 min.

An assessment is not possible if the test has been stopped according to 8.6.2.

In addition to reporting the results as given above, the following shall be reported for each specimen:

- 1) the maximum temperature recorded for each thermocouple and the time at which this occurs;
- 2) graphs of the temperatures recorded by each thermocouple with time;
- 3) record of sustained flaming of the specimen surface and time it occurs;
- 4) record of time of second application of extinguishing board within the 5 min period after removal of the burner flame, if required;
- 5) time to flaming at an edge.

11 Performance criteria and declaration

Based upon the results described in Clause 10, the following shall be reported and declared:

- test has been passed; the product does not show propensity for continuous smouldering combustion, or
- test has been failed; the product shows propensity for continuous smouldering combustion, or
- assessment of the propensity for continuous smouldering combustion is not possible.

12 Direct and extended application of test results

The field of application which includes direct and extended application of test results is defined in the relevant product standards.

It is assumed that the following product parameters have an influence on the smouldering behaviour of a product:

- density;
- thickness;
- composition;
- orientation.

These and other parameters should be addressed in the relevant product standard.

The test result is valid for the product which was tested.

The test result shall also be valid for products of greater thickness when the test specimen has been tested at a thickness of 100 mm.

13 Test report

The test report shall include the following information as a minimum. A clear distinction shall be made between the data provided by the sponsor and data determined by the test:

- a) reference that the test was carried out in accordance with EN 16733;
- b) any deviations from the test method;
- c) name and address of the testing laboratory;
- d) date and identification number of the report;
- e) name and address of the sponsor;
- f) name and address of the manufacturer/supplier, if known;
- g) date of test specimen arrival;
- h) identification of the product;
- i) for asymmetrical products, face tested;
- j) for directional products, orientation;
- k) description of the sampling procedure, where relevant;
- l) a general description of the product tested including density, mass per unit area and thickness, together with the details of construction of the test specimen;
- m) details of conditioning;
- n) date of test;
- o) test results and assessment expressed in accordance with Clauses 10, 11 and 12;
- p) all observations made during the test;
- q) photographs of the test specimens after test cut vertically through to show extent of smouldering;
- r) information on the intended application of the building product, if known;

- s) the statement 'the test results relate to the behaviour of the test specimens of a product under the particular conditions of the test; they are not intended to be the sole criterion for assessing the potential fire hazard of the product in use'.

Dimensions in mm

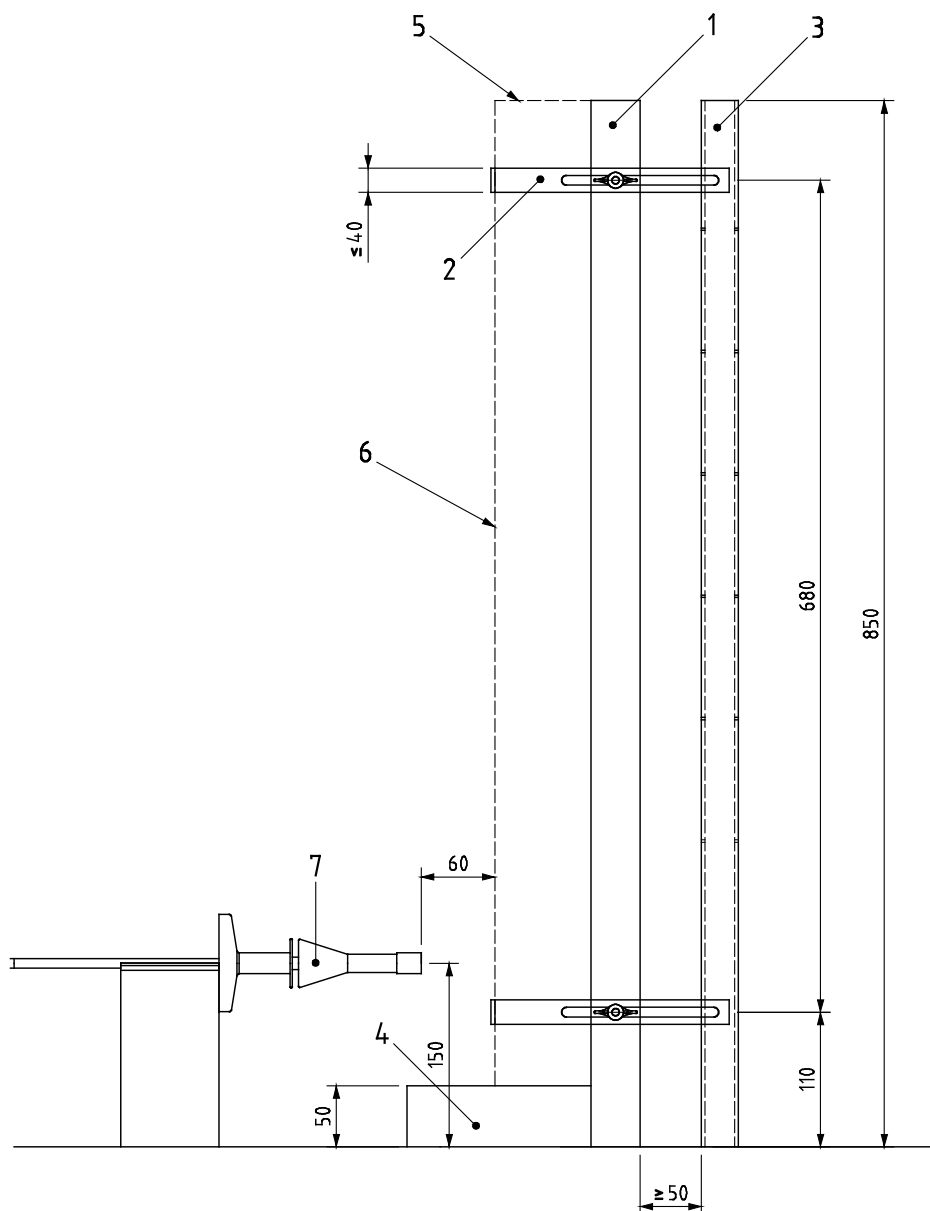

Key

- 1 sample support frame (40 × 40 × 850 mm)
- 2 clamps
- 3 TC support frame (40 × 80 × 850 mm)
- 4 support devices (50 × 50 × 100 mm)
- 5 free top edge test specimen
- 6 front of test specimen
- 7 Teclu burner (see Figure 7)

Figure 1 — Test apparatus - Side elevation

Dimensions in mm

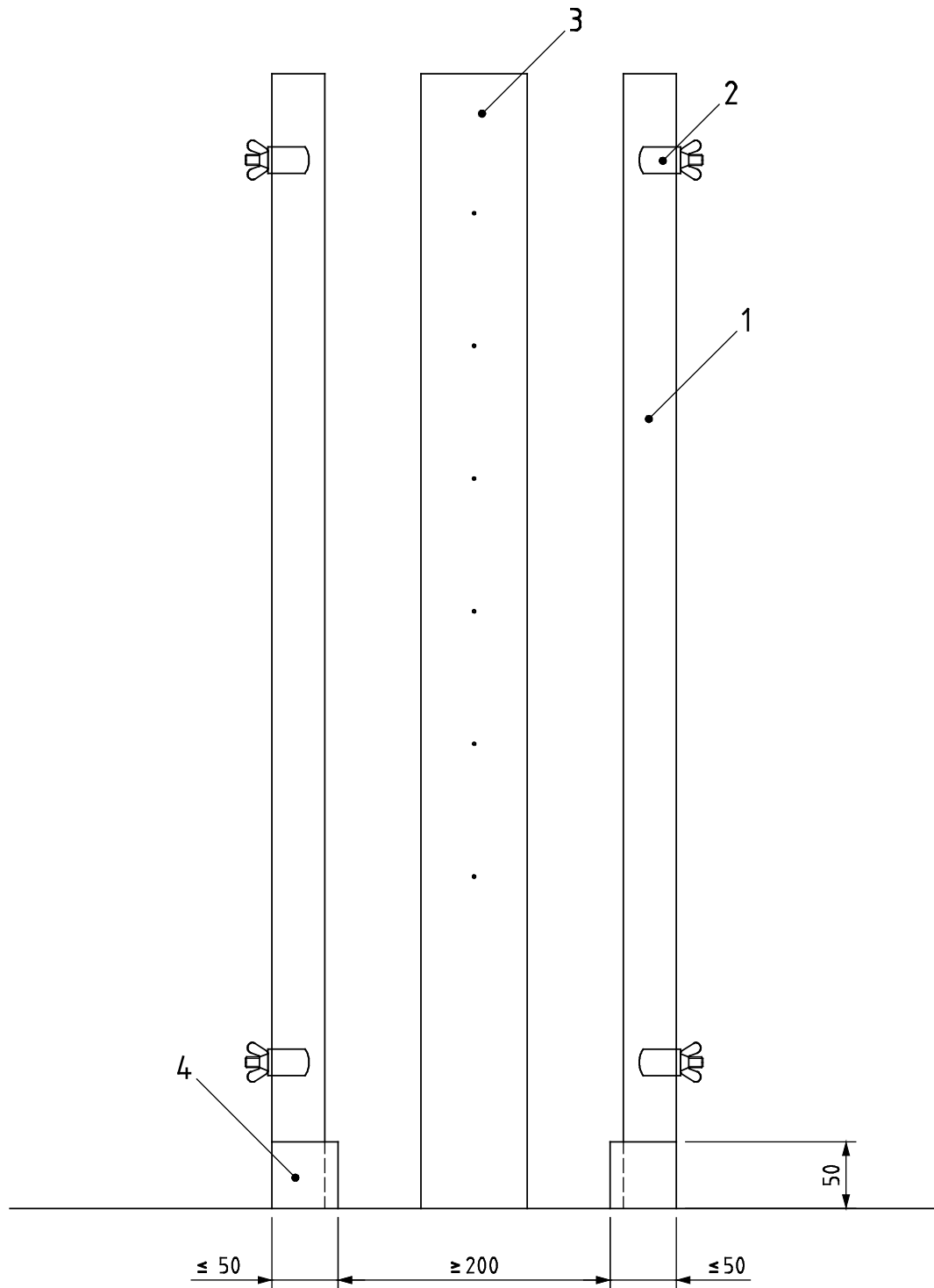

Key

- 1 sample support frame
- 2 clamps
- 3 TC support frame (40 × 80 × 850 mm)
- 4 support devices (50 × 50 × 100 mm)

Figure 2 — Test apparatus - Front elevation

Dimensions in mm

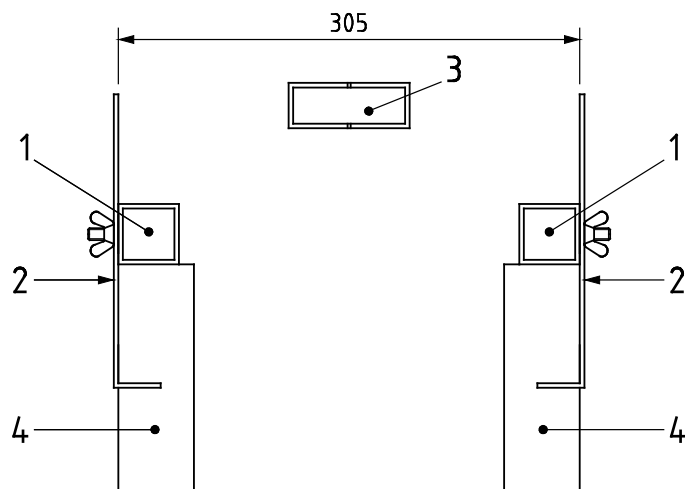

Key

- 1 sample support frame
- 2 clamps
- 3 TC support frame
- 4 support devices (50 × 50 × 100 mm)

Figure 3 — Test apparatus - Plan view

Dimensions in mm

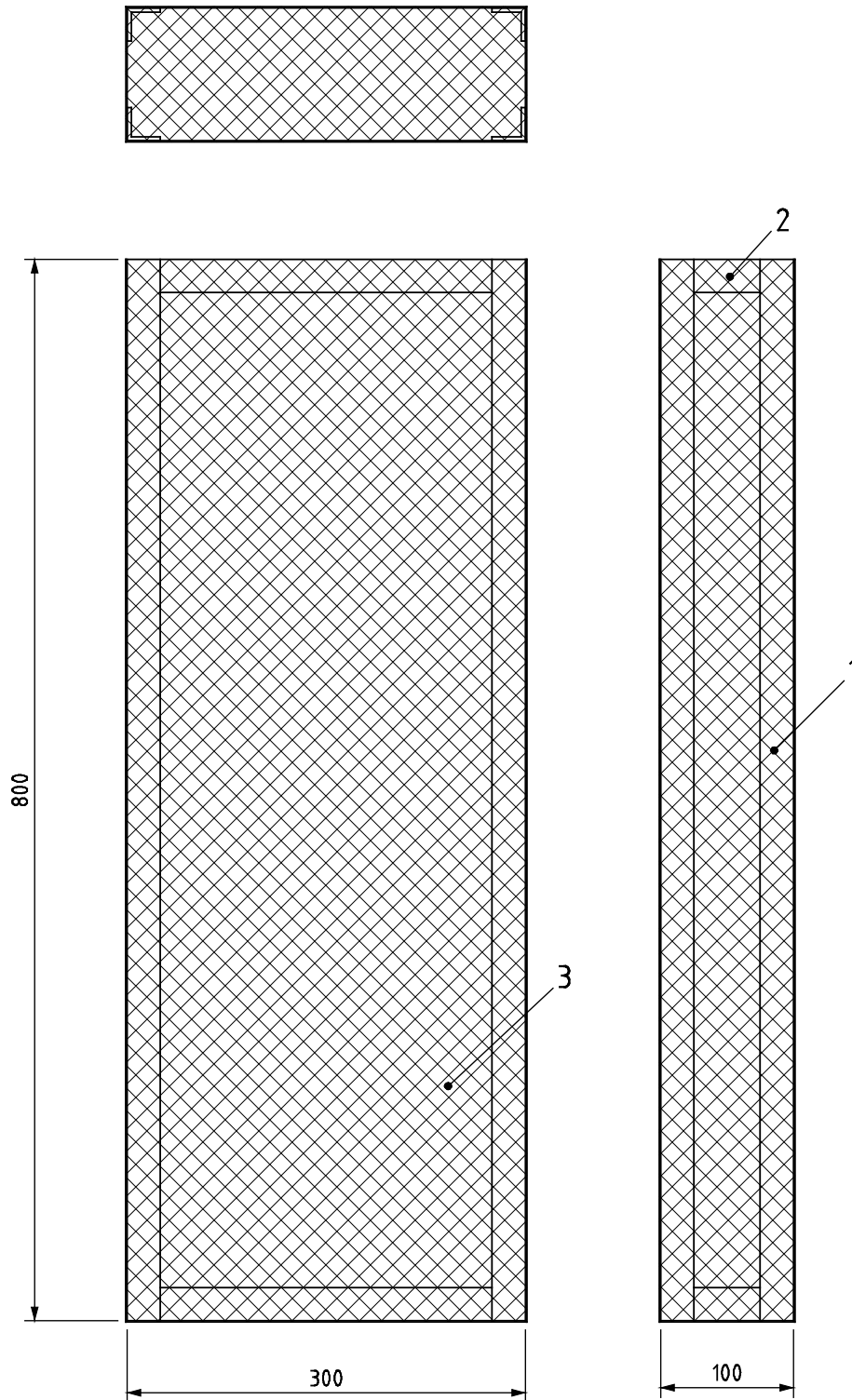

Key

- 1 steel L angle (15 × 15 × 3 mm)
- 2 steel flat plate (15 × 3 mm)
- 3 wire mesh (see 5.1.2 for specifications)

Figure 4 — Wire mesh box

Dimensions in mm

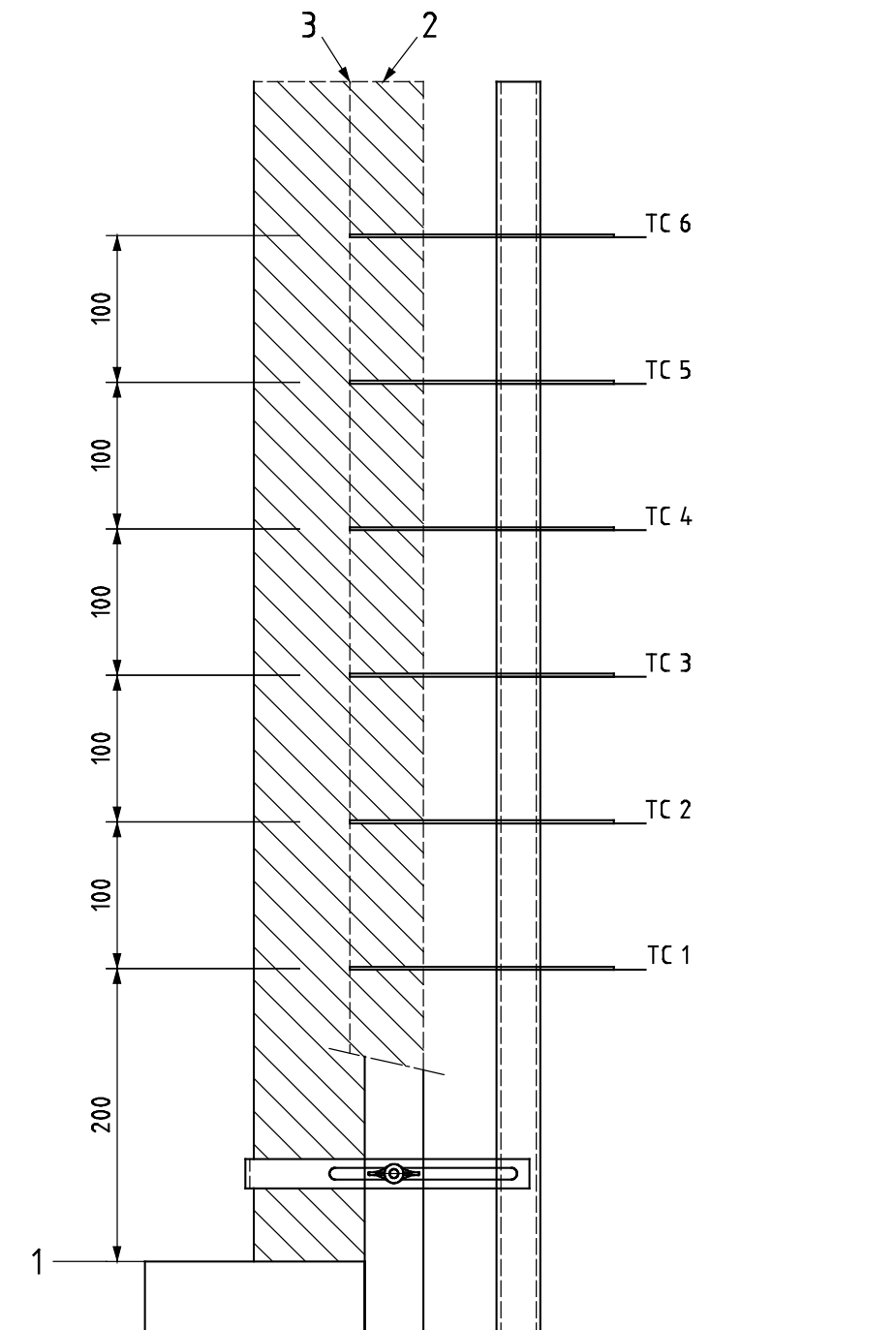

Key

- 1 bottom edge test specimen
- 2 test specimen
- 3 centre of test specimen

Figure 5 — Positions of thermocouples

Dimensions in mm

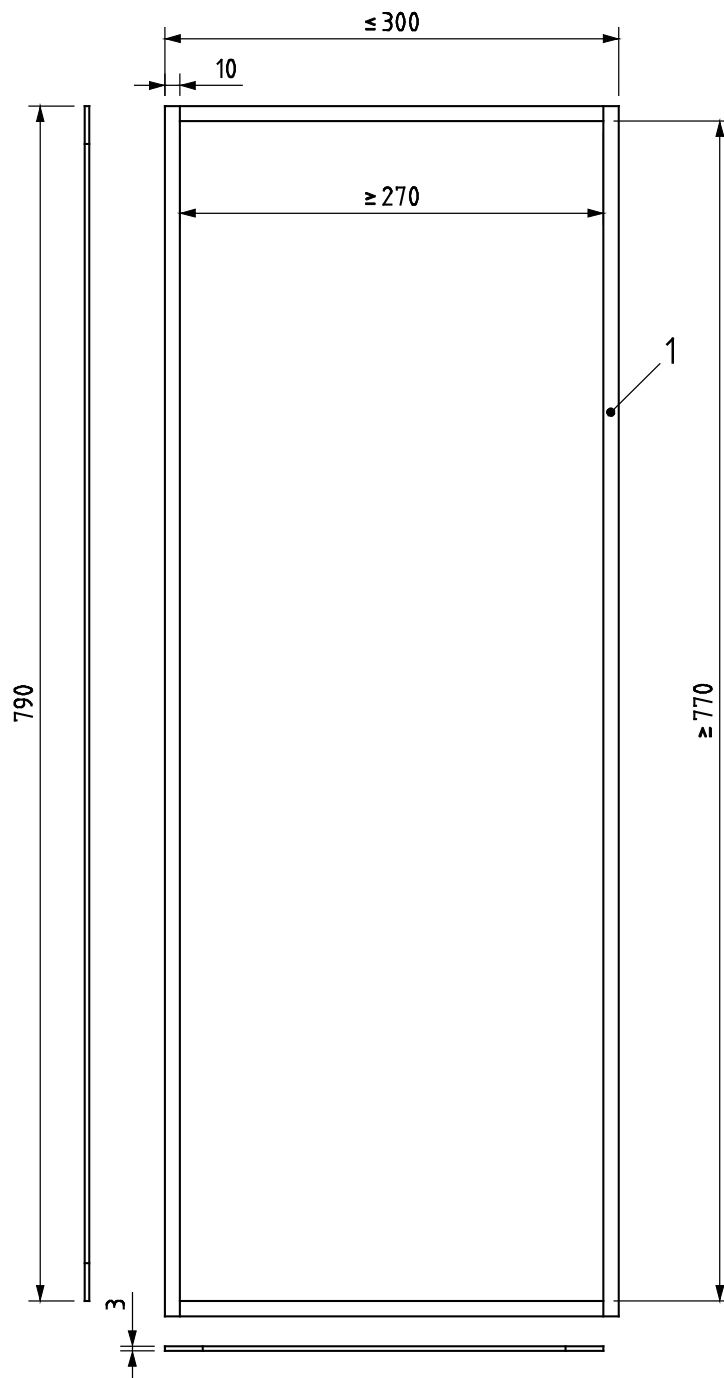

Key

1 steel strip (10 × 3 mm)

Figure 6 — Frame for flexible and thin products

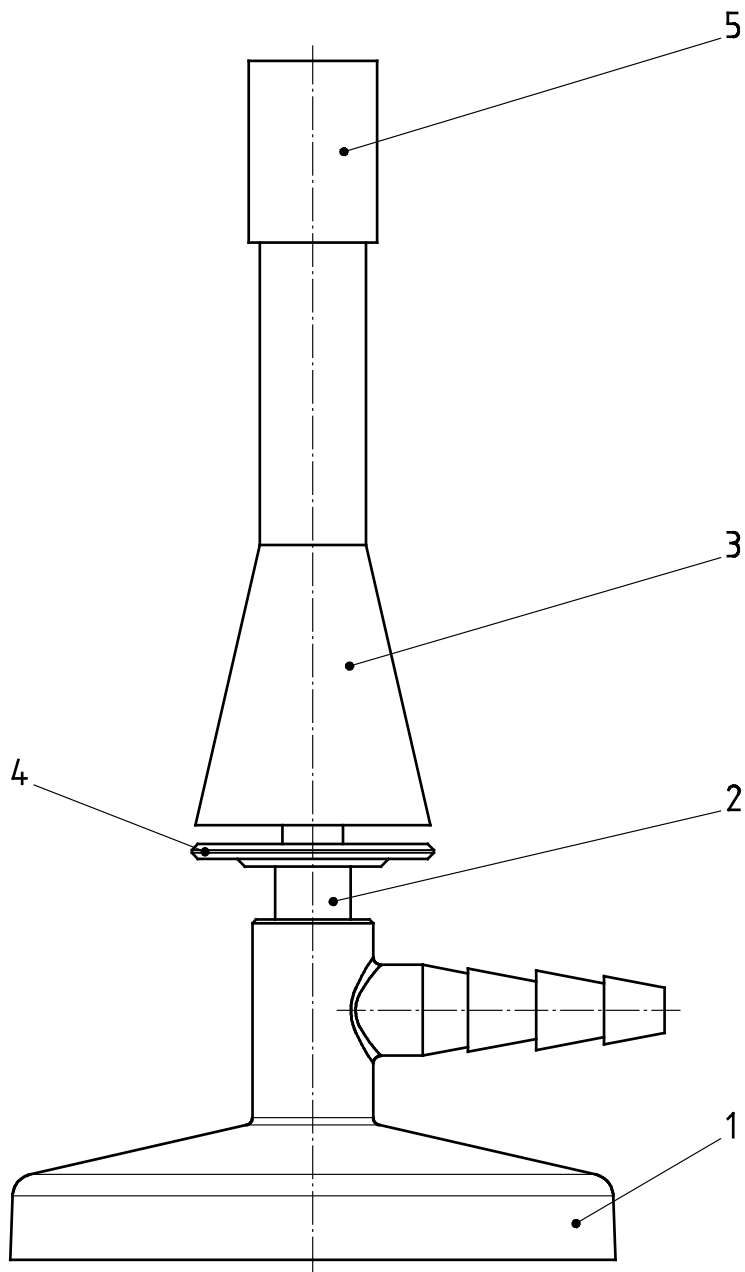

Key

- 1 stand (\varnothing 80 mm)
- 2 nozzle (\varnothing 0,55 mm)
- 3 Teclu tube (\varnothing 14 \times 86 mm) containing perforated disc
- 4 regulator (\varnothing 32 \times 3 mm)
- 5 burner outlet cap (outer \varnothing 17 mm, inner \varnothing 14 mm)

Figure 7 — Teclu burner

Annex A (informative)

Precision of the method

A.1 General

An inter-laboratory trial was conducted on the test method described in this European Standard. The trial involved 6 laboratories and 6 building products. Statistical analysis of the results of the trials on this test method was carried out in order to determine the repeatability and reproducibility of the method.

The data generated by this method consists of yes / no answers.

For these results, the numbers of the yes and no answers, as well as their relative proportions, were evaluated. Also included was an additional non-standard parameter called 'degree of uncertainty' which attempts to combine the proportions of yes and no answers to a single number: This quantity is calculated as $2 \times \min(\text{yes } \%, \text{no } \%)$; hence it equals zero if all the answers are yes or no and 100 % if half of the answers are yes and half of them are no.

The parameters analysed and other relevant details are given in Table A.1 below.

Table A.1

Parameter	Type
Occurrence of sustained flaming at the top edge or vertical sides	Yes/no
Re-ignition of the product 5 min after removal of the flame source	Yes/no
250K temperature rise recorded on Thermocouple 6	Yes/no

Table A.2 shows the results of the yes/no analysis for each of the application times and application areas. The results are consistent for some products and slightly variable for others, which has been shown to be more a function of material/product variation than test method variability.

Table A.2

Material	Smouldering (% Yes)	Sustained flaming at an edge (%)	Re-ignition more than 5 min after removal of flame (%)	Temperature rise greater than 250K (%)	Indication of uncertainty Values Values for Yes/No Answers
A	0	0	0	0	0
B	100	0	0	100	0
C	27	0	0	27	54
D	0	0	0	0	0
E	100	0	0	100	0
F	17	17	17	0	34

A.2 Conclusions

- a) The variability of the yes / no response for each product is generally a function of the product itself rather than the method.
- b) The relative reproducibility was good for all products tested, the differences being mainly related to product variability (see degree of uncertainty values).

Bibliography

EN 13501-1, *Fire classification of construction products and building elements — Part 1: Classification using data from reaction to fire tests*

British Standards Institution (BSI)

BSI is the national body responsible for preparing British Standards and other standards-related publications, information and services.

BSI is incorporated by Royal Charter. British Standards and other standardization products are published by BSI Standards Limited.

About us

We bring together business, industry, government, consumers, innovators and others to shape their combined experience and expertise into standards-based solutions.

The knowledge embodied in our standards has been carefully assembled in a dependable format and refined through our open consultation process. Organizations of all sizes and across all sectors choose standards to help them achieve their goals.

Information on standards

We can provide you with the knowledge that your organization needs to succeed. Find out more about British Standards by visiting our website at bsigroup.com/standards or contacting our Customer Services team or Knowledge Centre.

Buying standards

You can buy and download PDF versions of BSI publications, including British and adopted European and international standards, through our website at bsigroup.com/shop, where hard copies can also be purchased.

If you need international and foreign standards from other Standards Development Organizations, hard copies can be ordered from our Customer Services team.

Subscriptions

Our range of subscription services are designed to make using standards easier for you. For further information on our subscription products go to bsigroup.com/subscriptions.

With **British Standards Online (BSOL)** you'll have instant access to over 55,000 British and adopted European and international standards from your desktop. It's available 24/7 and is refreshed daily so you'll always be up to date.

You can keep in touch with standards developments and receive substantial discounts on the purchase price of standards, both in single copy and subscription format, by becoming a **BSI Subscribing Member**.

PLUS is an updating service exclusive to BSI Subscribing Members. You will automatically receive the latest hard copy of your standards when they're revised or replaced.

To find out more about becoming a BSI Subscribing Member and the benefits of membership, please visit bsigroup.com/shop.

With a **Multi-User Network Licence (MUNL)** you are able to host standards publications on your intranet. Licences can cover as few or as many users as you wish. With updates supplied as soon as they're available, you can be sure your documentation is current. For further information, email bsmusales@bsigroup.com.

Revisions

Our British Standards and other publications are updated by amendment or revision.

We continually improve the quality of our products and services to benefit your business. If you find an inaccuracy or ambiguity within a British Standard or other BSI publication please inform the Knowledge Centre.

Copyright

All the data, software and documentation set out in all British Standards and other BSI publications are the property of and copyrighted by BSI, or some person or entity that owns copyright in the information used (such as the international standardization bodies) and has formally licensed such information to BSI for commercial publication and use. Except as permitted under the Copyright, Designs and Patents Act 1988 no extract may be reproduced, stored in a retrieval system or transmitted in any form or by any means – electronic, photocopying, recording or otherwise – without prior written permission from BSI. Details and advice can be obtained from the Copyright & Licensing Department.

Useful Contacts:

Customer Services

Tel: +44 845 086 9001

Email (orders): orders@bsigroup.com

Email (enquiries): cservices@bsigroup.com

Subscriptions

Tel: +44 845 086 9001

Email: subscriptions@bsigroup.com

Knowledge Centre

Tel: +44 20 8996 7004

Email: knowledgecentre@bsigroup.com

Copyright & Licensing

Tel: +44 20 8996 7070

Email: copyright@bsigroup.com

BSI Group Headquarters

389 Chiswick High Road London W4 4AL UK