

BS EN 16714-2:2016



BSI Standards Publication

Non-destructive testing — Thermographic testing

Part 2: Equipment

National foreword

This British Standard is the UK implementation of EN 16714-2:2016.

The UK participation in its preparation was entrusted to Technical Committee WEE/46, Non-destructive testing.

A list of organizations represented on this committee can be obtained on request to its secretary.

This publication does not purport to include all the necessary provisions of a contract. Users are responsible for its correct application.

© The British Standards Institution 2016.
Published by BSI Standards Limited 2016

ISBN 978 0 580 86967 9

ICS 19.100

Compliance with a British Standard cannot confer immunity from legal obligations.

This British Standard was published under the authority of the Standards Policy and Strategy Committee on 31 August 2016.

Amendments/corrigenda issued since publication

Date	Text affected
------	---------------

EUROPEAN STANDARD

EN 16714-2

NORME EUROPÉENNE

EUROPÄISCHE NORM

August 2016

ICS 19.100

English Version

Non-destructive testing - Thermographic testing - Part 2: Equipment

Essais non destructifs - Analyses thermographiques -
Partie 2: EquipementZerstörungsfreie Prüfung - Thermografische Prüfung -
Teil 2: Geräte

This European Standard was approved by CEN on 25 June 2016.

CEN members are bound to comply with the CEN/CENELEC Internal Regulations which stipulate the conditions for giving this European Standard the status of a national standard without any alteration. Up-to-date lists and bibliographical references concerning such national standards may be obtained on application to the CEN-CENELEC Management Centre or to any CEN member.

This European Standard exists in three official versions (English, French, German). A version in any other language made by translation under the responsibility of a CEN member into its own language and notified to the CEN-CENELEC Management Centre has the same status as the official versions.

CEN members are the national standards bodies of Austria, Belgium, Bulgaria, Croatia, Cyprus, Czech Republic, Denmark, Estonia, Finland, Former Yugoslav Republic of Macedonia, France, Germany, Greece, Hungary, Iceland, Ireland, Italy, Latvia, Lithuania, Luxembourg, Malta, Netherlands, Norway, Poland, Portugal, Romania, Slovakia, Slovenia, Spain, Sweden, Switzerland, Turkey and United Kingdom.

EUROPEAN COMMITTEE FOR STANDARDIZATION
COMITÉ EUROPÉEN DE NORMALISATION
EUROPÄISCHES KOMITEE FÜR NORMUNG**CEN-CENELEC Management Centre: Avenue Marnix 17, B-1000 Brussels**

Contents

Page

European foreword.....	4
1 Scope	5
2 Normative references	5
3 Terms and definitions	5
4 Equipment	5
4.1 Selection of infrared camera	5
4.2 Classification of IR cameras	5
4.2.1 General	5
4.2.2 Temperature range	6
4.2.3 Thermal resolution	6
4.2.4 Spatial resolution and lenses	7
4.2.5 Frame rate and temporal resolution	7
4.2.6 Operating temperature range	7
4.2.7 Storage temperature range	7
4.2.8 Spectral filter	7
4.3 Accessories	8
4.3.1 Interchangeable lenses	8
4.3.2 IR mirrors	8
4.3.3 IR protective windows	8
4.3.4 IR camera protective housing	8
4.3.5 Examples of excitation sources for active thermography	8
5 Function check and traceability	9
5.1 General remarks	9
5.2 Checks by the user	9
5.3 Additional checks by the camera supplier	9
5.4 Frequency of function checks	9
Annex A (normative) Parameters and measuring methods for characterizing IR cameras	10
A.1 Instantaneous field of view (IFOV)	10
Figure A.1 — Instantaneous field of view (IFOV)	11
A.2 Field of view (FOV)	12
Figure A.2 — Field of view (FOV)	12
A.3 Slit response function (SRF)	13
Figure A.3 — Principle for the determination of the slit response function (SRF)	14
Figure A.4 — Slit response function (SRF)	15
A.4 Hole response function (HRF)	15
A.5 Noise Equivalent Temperature Difference (NETD)	16
A.6 Minimum resolvable temperature difference (MRTD)	16
Annex B (informative) Examples for accessories	17

B.1	Thermometer	17
B.2	Moisture measuring devices	17
B.3	Anemometer	17
B.4	Clamp-on ammeter	17
B.5	Cameras in the visible range	17
B.6	Endoscope	17
	Bibliography	18

European foreword

This document (EN 16714-2:2016) has been prepared by Technical Committee CEN/TC 138 “Non-destructive testing”, the secretariat of which is held by AFNOR.

This European Standard shall be given the status of a national standard, either by publication of an identical text or by endorsement, at the latest by February 2017, and conflicting national standards shall be withdrawn at the latest by February 2017.

Attention is drawn to the possibility that some of the elements of this document may be the subject of patent rights. CEN shall not be held responsible for identifying any or all such patent rights.

EN 16714, *Non-destructive testing — Infrared thermographic testing* consists of the following parts:

- *Part 1: General principles*
- *Part 2: Equipment*
- *Part 3: Terms and definitions*

According to the CEN-CENELEC Internal Regulations, the national standards organisations of the following countries are bound to implement this European Standard: Austria, Belgium, Bulgaria, Croatia, Cyprus, Czech Republic, Denmark, Estonia, Finland, Former Yugoslav Republic of Macedonia, France, Germany, Greece, Hungary, Iceland, Ireland, Italy, Latvia, Lithuania, Luxembourg, Malta, Netherlands, Norway, Poland, Portugal, Romania, Slovakia, Slovenia, Spain, Sweden, Switzerland, Turkey and the United Kingdom.

1 Scope

This European Standard describes properties and requirements of infrared cameras used for thermographic testing for non-destructive testing.

This document gives also examples of excitation sources, the properties and requirements are described in application standards for active thermography.

2 Normative references

The following documents, in whole or in part, are normatively referenced in this document and are indispensable for its application. For dated references, only the edition cited applies. For undated references, the latest edition of the referenced document (including any amendments) applies.

EN 16714-3, *Non-destructive testing — Infrared thermographic testing — Part 3: Terms and definitions*

3 Terms and definitions

For the purposes of this document, the terms and definitions given in EN 16714-3 apply.

4 Equipment

4.1 Selection of infrared camera

The infrared camera (IR camera) has to be selected according to the application and the temperature of the inspected object.

IR camera relevant parameters are:

- spectral sensitivity;
- temperature range;
- thermal resolution;
- spatial resolution;
- frame rate;
- temporal resolution.

These parameters shall be provided by the manufacturer.

4.2 Classification of IR cameras

4.2.1 General

IR cameras are classified according to detector arrangement and working principle.

The classification according to the detector arrangement is:

- single element detector with two-dimensional opto-mechanical scanning;
- line scanner with one-dimensional opto-mechanical scanning or linear array;

- two-dimensional detector matrix without mechanical scanning (Focal Plane Array, FPA).

Mechanical scanning is achieved by moving mirrors and/or prisms. However, the frame rate is limited due to the scanning. They are therefore less applicable to capture fast processes than FPA-cameras.

The classification according to the detector working principle is:

- thermal detectors;
- quantum detectors.

Thermal detectors, e.g. microbolometers or pyroelectric detectors, work at room temperature. Quantum detectors have to be cooled down to very low temperatures. Cooling is accomplished with multi-stage Peltier elements (thermo-electric), liquid nitrogen, expansion devices or refrigeration machines (Stirling engine). Quantum detectors have a higher sensitivity (specific detectivity D^*) and can achieve higher frame rates than thermal detectors.

IR cameras can be just imagers or radiometric calibrated devices. IR-imagers are sufficient for qualitative tasks like hot spot detection or analysis of radiation distributions. Radiometric calibrated IR-cameras allow for the measurements of radiance, temperature differences or absolute temperatures provided that object parameters, such as (but not limited to) emissivity and reflected apparent temperature are known.

IR cameras are adapted to the transmission properties of the atmosphere for infrared radiation (atmospheric windows):

- short Wave, SW: wavelength between approx. 0,8 μm and 2,0 μm ;
- mid Wave, MW: wavelength between approx. 2,0 μm and 5,0 μm ;
- long Wave, LW: wavelength between approx. 8,0 μm and 14,0 μm .

4.2.2 Temperature range

The temperature range is the interval between lowest and highest measurable temperature. The range should be specified for black-body temperatures (emissivity = 1).

NOTE 1 Temperature range means the total temperature range, which can consist of several partial measurement ranges that can be adjusted separately at the device.

NOTE 2 The use of optical components like spectral filters can alter the measurable temperature range.

4.2.3 Thermal resolution

The thermal resolution describes the ability of an IR camera to resolve small temperature differences. The thermal resolution is commonly described by the noise equivalent temperature difference (NETD, see A.5).

The thermal resolution depends among others on:

- the object temperature;
- the integration time or response time;
- the temperature range.

Therefore, it shall be specified at least with indication of these values.

The required thermal resolution depends strongly on the application.

NOTE Typical values for the thermal resolution for object temperatures around 300 K are 0,05 K for uncooled thermal detectors and 0,02 K for cooled quantum detectors.

4.2.4 Spatial resolution and lenses

The spatial resolution describes the ability of an IR camera to resolve small objects or details. The spatial resolution is commonly quantified with the *slit response function* (SRF, see A.3), *hole response function* (HRF, see A.4) or the *instantaneous field of view* (IFOV, see A.1) which is field of view for a single detector element.

These specifications are needed to calculate the spot size diameter. They depend not only on the camera itself but also on the field of view of the lens. The spot size diameter also depends on the distance between the camera and the object.

The required spatial resolution of the combination IR camera / lens depends strongly on the size of the investigated object or object detail.

NOTE A typical value for the horizontal viewing angle of a single detector element is 1 mrad (for a lens with a 20° field of view and a detector matrix of 320 horizontal detector elements).

The minimum resolvable temperature difference (MRTD, see A.6) considers thermal as well as spatial resolution of IR cameras including the observer. The MRTD characterizes the ability of the combined system IR camera and human observer to resolve small temperature differences at small structures in relation with the whole FOV (see A.2).

4.2.5 Frame rate and temporal resolution

The frame rate is the number of frames which are read out from the detector per time unit.

NOTE 1 If windowed frames are selected the frame rate can be higher.

The maximum frame rate is limited by the read out circuit. Other parameters such as (but not limited to) integration time, read out mode (integrate then read, integrate while read) and response time may also impact the maximum frame rate. Temporal and thermal resolution are closely connected.

For quantum detectors, for defined object conditions highest thermal resolution is achieved with long integration times, which in turn limits the maximum frame rate.

The temporal resolution of IR cameras is important for capturing moving objects (or for moving cameras) as well as fast temperature changes.

NOTE 2 Typical values for frame rates are for scanning cameras with a single detector element around 30 s⁻¹, for FPA cameras with uncooled thermal detectors around 60 s⁻¹ and for FPA cameras with cooled quantum detectors up to 300 s⁻¹ for full frames and up to 70 000 s⁻¹ for windowed frames.

4.2.6 Operating temperature range

The operating temperature range is the intended ambient temperature range for operating the camera. The operating temperature range is provided by the manufacturer of the camera.

4.2.7 Storage temperature range

The storage temperature range is the intended ambient temperature for storing the camera. The storage temperature range is provided by the manufacturer of the camera.

4.2.8 Spectral filter

Spectral filters limit the spectral sensitivity range of IR cameras. They are used to adapt the camera to material specific emission or absorption properties and/or adjust the temperature measurement range.

In many cases MW cameras are used for analysing material properties because many absorption and transmission bands lay within the wavelength range between 2 μm and 5 μm . Examples are measurements through/on glass, plastics, flames, gases, etc. The absorption and transmission bands should be known beforehand so that the right filters can be chosen.

4.3 Accessories

4.3.1 Interchangeable lenses

Interchangeable lenses are used to adapt the camera system to specific spatial requirements of measurement tasks (image area, required minimal spatial resolution, working distance).

There are standard lenses, e.g. wide angle and telephoto lenses as well as accessory lenses for the measurement of small objects. For calibrated cameras the calibration process shall include each lens together with the camera.

4.3.2 IR mirrors

IR mirrors are flat highly polished metal surfaces that reflect infrared radiation. They are usually used for imaging of inaccessible objects or object parts.

4.3.3 IR protective windows

IR protective windows consist of materials with good transmission properties for infrared radiation. They are used to protect the lens from mechanical and/or chemical damage or high environmental temperatures.

4.3.4 IR camera protective housing

Protective housings protect IR cameras against extreme environmental conditions like:

- heat;
- dust;
- water;
- aggressive chemical substances;
- strong magnetic and electric fields;
- mechanical damage;
- explosive atmospheres.

4.3.5 Examples of excitation sources for active thermography

4.3.5.1 Flash lamps

Flash lamps heat up the surface of the investigated object with very short light pulses (pulse thermography).

4.3.5.2 Lamps, LED and laser

Lamps, LED and laser are used for modulated or pulsed excitation of the investigated object.

4.3.5.3 Hot or cold air

Hot or cold air is used for convective heating or cooling of the investigated object.

4.3.5.4 Induction coils

Induction coils are used for contactless heating of electrically conductive objects.

4.3.5.5 Mechanical excitation

Objects can also be excited by mechanical excitation (e.g. by ultrasound or vibration sources). Certain object areas are selectively heated up because of mechanical losses (e.g. hysteresis, Coulomb friction).

5 Function check and traceability

5.1 General remarks

The functioning of all devices has to be checked regularly. This includes checking of mechanical, optical, and electronic properties, as well as the correct functioning of the software.

5.2 Checks by the user

The following items shall be checked before starting a test:

- the starting procedure and general function check (live image, reaction on pushing buttons);
- image quality (focusing, thermal resolution, non-uniformity correction (NUC));
- data storage (store and open IR images);
- temperature calibration (e.g. with black-body): cameras that are used for quantitative measurements of temperatures or temperature differences shall be calibrated with sufficient accuracy according to the international temperature scale.

5.3 Additional checks by the camera supplier

Check of accuracy of temperature measurement according to traceable standards (new calibration if necessary).

5.4 Frequency of function checks

- a) by the user: before every use and after any malfunction of the device;
- b) by the camera supplier: according to the recommended service and calibration intervals.

Annex A (normative)

Parameters and measuring methods for characterizing IR cameras

A.1 Instantaneous field of view (IFOV)

	Alternative name	detector footprint
	specifies the	theoretical spatial resolution of an IR camera, with a certain lens.
	meaning:	It is the one dimensional angle subtended by the detector area. For a matrix detector, one refers to horizontal IFOV and vertical IFOV, see Figure A.1. For a FPA it corresponds to the field of view for a pixel.
	<u>definition</u>	optical projection of a single detector or detector element (backwards) through an <i>ideal</i> optical system on the measured object. <u>Equation</u> : $IFOV = \text{pixel size} / \text{focal length}$
	Physical quantity: Unit:	angle radian (typically mrad)
	Notes:	<p>1. Has to be specified for each lens separately.</p> <p>2. Has to be specified for each detector direction separately.</p> <p>3. Based on the IFOV value in mrad and the object distance d in m the theoretically smallest spot size (frequently termed ideal spot size) x_{ideal} in mm (for quadratic detectors) can be calculated: $x_{\text{ideal}} = d \times IFOV$</p> <p>4. Based on the IFOV-value in mrad the real spot size x_{real} in mm (for quadratic detectors) can be calculated as follows (where f_{optic} is a correction term): $x_{\text{real}} = d \times IFOV \times f_{\text{optic}}$</p> <p>In the real life, optics cannot be considered geometric. Edges of targets get blurred by diffraction and aberrations in the lens. This softening of edges leads to uncertainty in the size measurements of targets, as well as a change in radiance for edge pixels.</p>

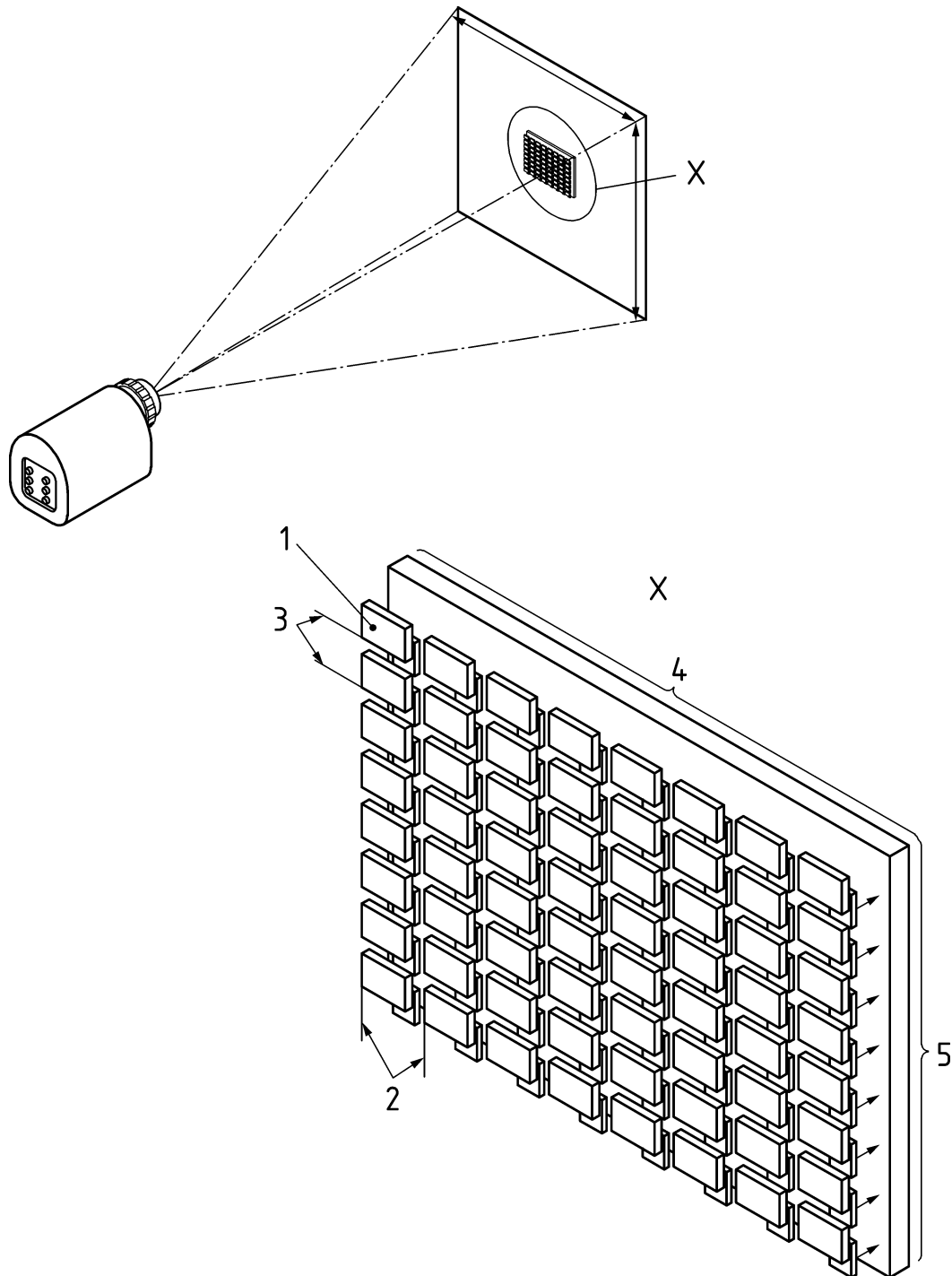

Key

- 1 one single pixel
- 2 $IFOV_H$ Horizontal instantaneous field of view
- 3 $IFOV_V$ Vertical instantaneous field of view
- 4 field of view in horizontal direction
- 5 field of view in vertical direction

Figure A.1 — Instantaneous field of view (IFOV)

A.2 Field of view (FOV)

	specifies the	optical system of IR cameras and lenses
	meaning:	The total angular dimensions within which objects can be imaged and displayed both in the horizontal and vertical directions (see Figure A.2).
	measuring specification	The field of view of scanning cameras is characterized by the horizontal and vertical scanning angle. The focal length of the lens is taken into account. When focused to infinity, for a focal plane array detector the field of view is calculated from the size of the detector array (x,y) and the focal length (f) of the lens. <u>Equation:</u> $FOV_H = 2\arctan(x/2f)$ and $FOV_V = 2\arctan(y/2f)$
	Physical quantity:	angle
	Unit:	degrees or radian (typically degrees)
	Notes:	1. Has to be specified for each lens separately.

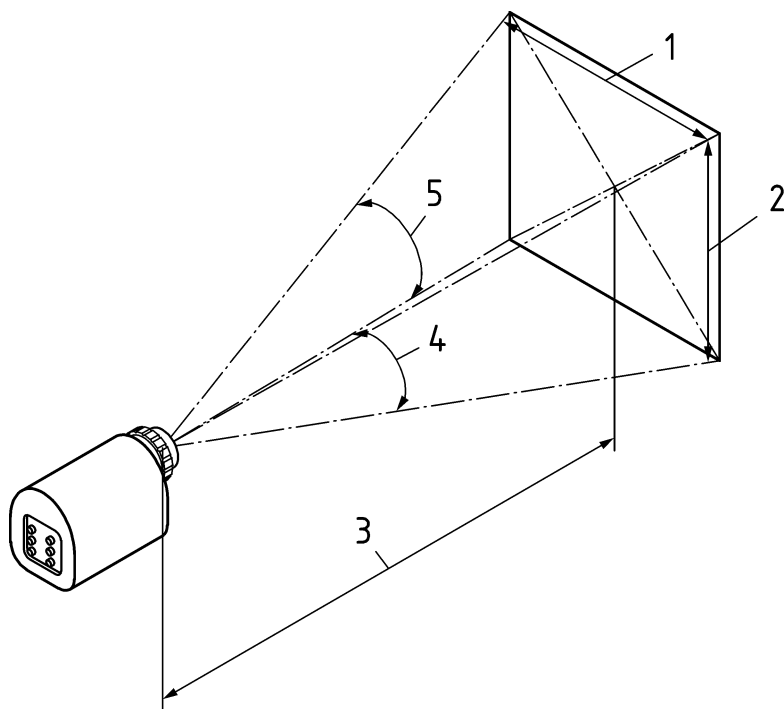

Key

- 1 size of image in horizontal direction
- 2 size of image in vertical direction
- 3 distance d
- 4 FOV_H Horizontal field of view
- 5 FOV_V Vertical field of view

Figure A.2 — Field of view (FOV)

A.3 Slit response function (SRF)

	specifies the	measured spatial resolution of an IR camera and the used lens, either horizontal and/or vertical
	meaning:	image detail which is resolvable by an IR camera
	measuring specification	<p>A SRF experimental set-up consists of three components:</p> <ul style="list-style-type: none"> • An extended wide black-body. • A system of slits of variable widths. This can be a mechanical sliding slit, or a set of plates with interchangeable machined slits. • An IR camera. <p>The camera looks at the black-body through the slit. The basic analysis tool is a line placed perpendicularly to the slit (see Figure A.3). The shape of the profile graph varies according to the slit width.</p> <p>From these raw graphs, a relative response value is extracted. It is a dimensionless quantity equal to the current max-to-min amplitude of the graph, divided by the max-to-min amplitude of the same graph when the slit is wide open.</p> <p>The final step consists in drawing the SRF curve (see Figure A.4). It shows the response value in percent (on the y-axis), as a function of the slit width (on the x-axis). The x-axis is traditionally graduated in angle (mrad).</p> <p>The angle at which the response is 50 % (1,1 mrad in the graph) (see Figure A.4) corresponds to the IFOV, or the pixel angular projection in the FOV.</p> <p>The angle corresponding to 95 % (3,5 mrad in the graph) is widely accepted as the horizontal (or vertical) measuring limit of the equipment (see Figure A.4). It is called the Measurement Field Of View – MFOV. It is a real measuring feature.</p>
	Physical quantity:	Angle
	Unit:	Radian, typically milliradian
	Notes:	<ol style="list-style-type: none"> 1. Shall be specified for each lens separately. 2. The slit response function cannot be obtained from temperature values. The original data shall be linear with the measured radiance. Therefore, it can be the radiance itself if the camera is calibrated in radiance, or any other linearized quantity (e.g. analog values, digital levels, digital counts). 3. Together with the SRF it is recommended to provide the distance at which it was recorded.

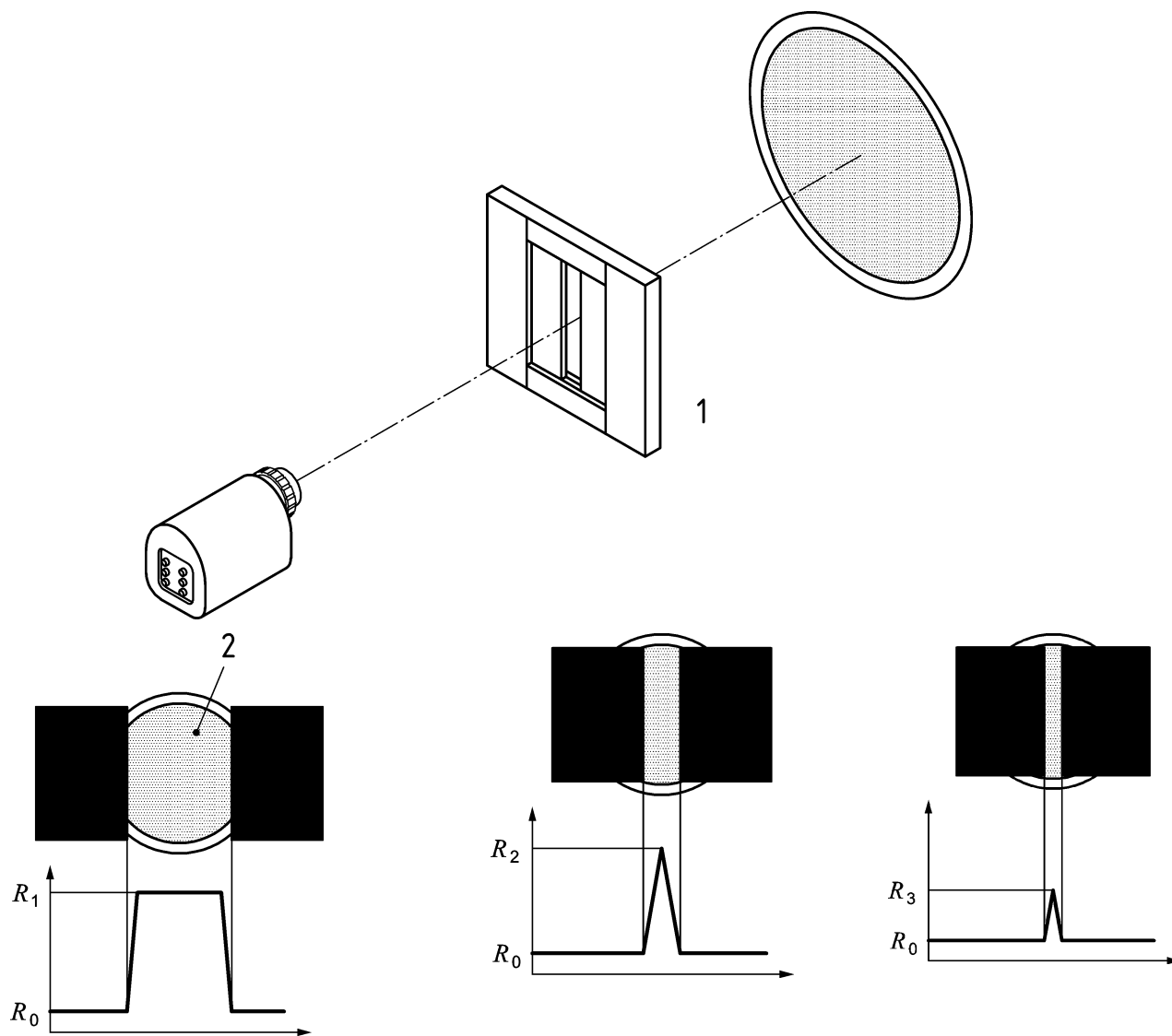

Key

1 system of slits of variable widths

2 black-body at temperature T_2

R_0 Response to temperature T_1 of the slits

R_1 Response to black-body temperature T_2 with open slits

R_2 Response to black-body temperature T_2 with less slit width

R_3 Response to black-body temperature T_2 with even more less slit width

Figure A.3 — Principle for the determination of the slit response function (SRF)

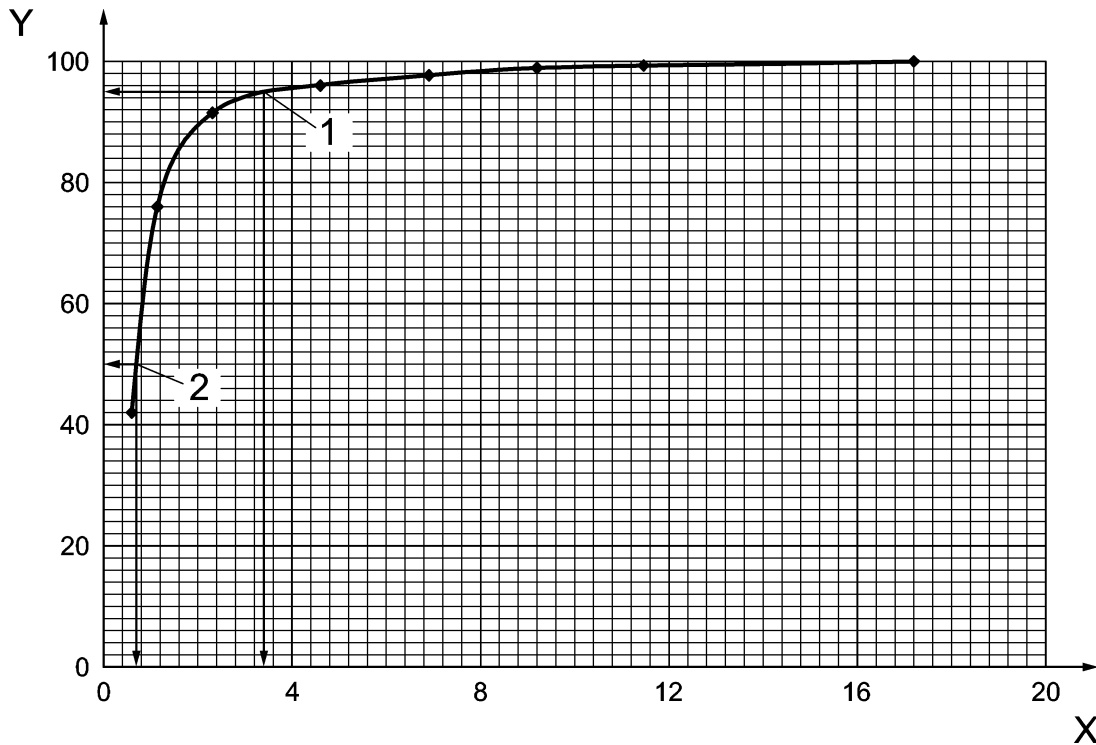

Key

X Slit width in angle (mrad)

Y Relative slit response value in %

1 Measurement point at 95 % slit response corresponds to the Measurement Field of View (MFOV)

2 Measurement point at 50 % slit response corresponds to the Instantaneous Field of View (IFOV)

Figure A.4 — Slit response function (SRF)

A.4 Hole response function (HRF)

	specifies the	Measurement capability for two dimensional objects (for FPAs only)
	meaning:	The HRF method is an extrapolation of the SRF method to two dimensions. Instead of looking at a black-body through linear slits of various widths, the camera looks through concentric holes of various diameters.
	measuring specification	Measurement of the two dimensional FOV instead of the one dimensional FOV as for the SRF. The resolution is typically expressed by the ratio between the distance of measurement to the hole diameter. The measurement resolution corresponds to the ratio giving 95 % of relative response. The HRF makes use of two analysis tools: the maximum measured over the hole, and the average on a reference zone considered as the ambience. A difference (Delta) between the two is considered.

Physical quantity:	Ratio distance-to-diameter
Unit:	NA
Notes:	The HRF cannot be obtained from temperature values. The original data shall be linear with the measured radiance. Therefore, it can be the radiance itself if the camera is calibrated in radiance, or any other linearized quantity (e. g, analog values, digital levels, digital counts).

A.5 Noise Equivalent Temperature Difference (NETD)

Alternative name	Noise Equivalent Difference Temperature (NEDT, NE ΔT)
specifies the	thermal resolution of IR cameras
meaning:	smallest resolvable temperature difference with a certain IR camera; it is the temperature difference which would generate a signal equal to the cameras temporal noise.
measuring specification (simplified)	<p>The NETD is calculated by dividing the temporal noise by the responsivity of the camera system.</p> <p>The responsivity per K can be calculated from the difference of the measured intensities of thermal sequences recorded at two different blackbody temperatures, divided by the temperature difference.</p> <p>The temporal noise array is calculated from the standard deviation of each pixel of a short time (typically 1 s) thermal sequence recorded at a blackbody temperature of e.g. 30 °C. The mean value of this noise array divided by the responsivity gives the NETD.</p> <p><u>Result:</u> ΔT</p>
Physical quantity:	temperature difference ΔT
Unit:	K
Notes:	<ol style="list-style-type: none"> 1. Shall be specified for a certain frame rate and integration time without time averaging; 2. Shall be specified for a certain black-body temperature; 3. The NETD corresponds to a signal-to-noise ratio of 1. An appropriate measurement might need a higher value.

A.6 Minimum resolvable temperature difference (MRTD)

The MRTD shall be determined according to the relevant standards (for example: ASTM E 1213-97).

Annex B (informative)

Examples for accessories

B.1 Thermometer

Thermometers are measurement devices to determine temperatures of matter.

Depending on the measuring principle, it is distinguished between contact and radiation thermometers. In thermography practice, contact thermometers are used for measuring ambient temperatures and point wise surface temperatures to determine emission coefficients.

B.2 Moisture measuring devices

Moisture measuring devices are used to determine relative and absolute moisture contents in gases, liquids, and solids. In thermography practice, moisture measuring devices are used to measure ambient humidity and moisture in masonry and insulation materials.

B.3 Anemometer

Anemometers are measurement devices to estimate flow velocities of air. In thermography practice, turbine, cup, and hot wire anemometers are used to measure wind speed.

B.4 Clamp-on ammeter

Clamp-on ammeters are measurement devices to determine currents in electrical conductors. In electrical thermography practice, clamp-on ammeters are used to measure instantaneous currents. Thermal abnormalities indicate possible temperature rises at nominal currents.

B.5 Cameras in the visible range

In thermography practice, cameras in visible range are used to photograph the thermographically analysed objects

B.6 Endoscope

Endoscopes are optical devices for visual analysis of cavities behind surfaces.

Bibliography

- [1] EN 16714-1, *Non-destructive testing — Thermographic testing — Part 1: General principles*
- [2] EN 13187, *Thermal performance of buildings - Qualitative detection of thermal irregularities in building envelopes - Infrared method (ISO 6781)*
- [3] EN ISO 9288, *Thermal insulation - Heat transfer by radiation - Physical quantities and definitions (ISO 9288)*
- [4] EN ISO 9712, *Non-destructive testing - Qualification and certification of NDT personnel (ISO 9712)*
- [5] ASTM E 1213, *Standard test method for minimum resolvable temperature difference of thermal imaging systems*
- [6] ASTM E 1543-93, *Standard test method for noise equivalent temperature difference of thermal imaging systems*
- [7] Gerald C. Holst, *Testing and Evaluation of Infrared Imaging Systems*, ISBN 0819428264, Verlag: SPIE – International Society for Optical Engineering
- [8] *Non destructive Testing Handbook Vol. 3. Infrared and Thermal testing, Chapter 11: Techniques of Infrared Thermography*, American Society for Nondestructive Testing, S. 318 bis 327, ISBN 1-57117-044-8
- [9] SCHUSTER N., KOLOBRODOV V.G. *Infrarotthermographie*. Wiley-VCH, Berlin, 2000
- [10] ROGALSKI A. *Infrared Detectors*. CRC Press Taylor and Francis Group, Second Edition, 2011
- [11] *The Thermography Monitoring Handbook*, First Edition, Roderick A. Thomas Coxmoor Publishing Company, 1999 ISBN 1 90189 201 8

British Standards Institution (BSI)

BSI is the national body responsible for preparing British Standards and other standards-related publications, information and services.

BSI is incorporated by Royal Charter. British Standards and other standardization products are published by BSI Standards Limited.

About us

We bring together business, industry, government, consumers, innovators and others to shape their combined experience and expertise into standards-based solutions.

The knowledge embodied in our standards has been carefully assembled in a dependable format and refined through our open consultation process. Organizations of all sizes and across all sectors choose standards to help them achieve their goals.

Information on standards

We can provide you with the knowledge that your organization needs to succeed. Find out more about British Standards by visiting our website at bsigroup.com/standards or contacting our Customer Services team or Knowledge Centre.

Buying standards

You can buy and download PDF versions of BSI publications, including British and adopted European and international standards, through our website at bsigroup.com/shop, where hard copies can also be purchased.

If you need international and foreign standards from other Standards Development Organizations, hard copies can be ordered from our Customer Services team.

Copyright in BSI publications

All the content in BSI publications, including British Standards, is the property of and copyrighted by BSI or some person or entity that owns copyright in the information used (such as the international standardization bodies) and has formally licensed such information to BSI for commercial publication and use.

Save for the provisions below, you may not transfer, share or disseminate any portion of the standard to any other person. You may not adapt, distribute, commercially exploit, or publicly display the standard or any portion thereof in any manner whatsoever without BSI's prior written consent.

Storing and using standards

Standards purchased in soft copy format:

- A British Standard purchased in soft copy format is licensed to a sole named user for personal or internal company use only.
- The standard may be stored on more than 1 device provided that it is accessible by the sole named user only and that only 1 copy is accessed at any one time.
- A single paper copy may be printed for personal or internal company use only.

Standards purchased in hard copy format:

- A British Standard purchased in hard copy format is for personal or internal company use only.
- It may not be further reproduced – in any format – to create an additional copy. This includes scanning of the document.

If you need more than 1 copy of the document, or if you wish to share the document on an internal network, you can save money by choosing a subscription product (see 'Subscriptions').

Reproducing extracts

For permission to reproduce content from BSI publications contact the BSI Copyright & Licensing team.

Subscriptions

Our range of subscription services are designed to make using standards easier for you. For further information on our subscription products go to bsigroup.com/subscriptions.

With **British Standards Online (BSOL)** you'll have instant access to over 55,000 British and adopted European and international standards from your desktop. It's available 24/7 and is refreshed daily so you'll always be up to date.

You can keep in touch with standards developments and receive substantial discounts on the purchase price of standards, both in single copy and subscription format, by becoming a **BSI Subscribing Member**.

PLUS is an updating service exclusive to BSI Subscribing Members. You will automatically receive the latest hard copy of your standards when they're revised or replaced.

To find out more about becoming a BSI Subscribing Member and the benefits of membership, please visit bsigroup.com/shop.

With a **Multi-User Network Licence (MUNL)** you are able to host standards publications on your intranet. Licences can cover as few or as many users as you wish. With updates supplied as soon as they're available, you can be sure your documentation is current. For further information, email subscriptions@bsigroup.com.

Revisions

Our British Standards and other publications are updated by amendment or revision.

We continually improve the quality of our products and services to benefit your business. If you find an inaccuracy or ambiguity within a British Standard or other BSI publication please inform the Knowledge Centre.

Useful Contacts

Customer Services

Tel: +44 345 086 9001

Email (orders): orders@bsigroup.com

Email (enquiries): cservices@bsigroup.com

Subscriptions

Tel: +44 345 086 9001

Email: subscriptions@bsigroup.com

Knowledge Centre

Tel: +44 20 8996 7004

Email: knowledgecentre@bsigroup.com

Copyright & Licensing

Tel: +44 20 8996 7070

Email: copyright@bsigroup.com

BSI Group Headquarters

389 Chiswick High Road London W4 4AL UK