

BS EN 16602-70-13:2015



BSI Standards Publication

Space product assurance — Measurements of the peel and pull-off strength of coatings and finishes using pressure- sensitive tapes

bsi.

...making excellence a habit.™

National foreword

This British Standard is the UK implementation of EN 16602-70-13:2015. It supersedes BS EN 14099:2001 which is withdrawn.

The UK participation in its preparation was entrusted to Technical Committee ACE/68, Space systems and operations.

A list of organizations represented on this committee can be obtained on request to its secretary.

This publication does not purport to include all the necessary provisions of a contract. Users are responsible for its correct application.

© The British Standards Institution 2015. Published by BSI Standards Limited 2015

ISBN 978 0 580 86499 5

ICS 49.140

Compliance with a British Standard cannot confer immunity from legal obligations.

This British Standard was published under the authority of the Standards Policy and Strategy Committee on 28 February 2015.

Amendments issued since publication

Date	Text affected
------	---------------

English version

Space product assurance - Measurements of the peel and pull-off strength of coatings and finishes using pressure-sensitive tapes

Assurance produit des projets spatiaux - Mesure de la force d'arrachement des revêtements et apprêts de rubans auto-adhésifs

Raumfahrtproduktsicherung - Ermittlung der Schäl- und Abziehfestigkeit von Überzügen und Beschichtungen unter Anwendung von Haftbändern

This European Standard was approved by CEN on 11 October 2014.

CEN and CENELEC members are bound to comply with the CEN/CENELEC Internal Regulations which stipulate the conditions for giving this European Standard the status of a national standard without any alteration. Up-to-date lists and bibliographical references concerning such national standards may be obtained on application to the CEN-CENELEC Management Centre or to any CEN and CENELEC member.

This European Standard exists in three official versions (English, French, German). A version in any other language made by translation under the responsibility of a CEN and CENELEC member into its own language and notified to the CEN-CENELEC Management Centre has the same status as the official versions.

CEN and CENELEC members are the national standards bodies and national electrotechnical committees of Austria, Belgium, Bulgaria, Croatia, Cyprus, Czech Republic, Denmark, Estonia, Finland, Former Yugoslav Republic of Macedonia, France, Germany, Greece, Hungary, Iceland, Ireland, Italy, Latvia, Lithuania, Luxembourg, Malta, Netherlands, Norway, Poland, Portugal, Romania, Slovakia, Slovenia, Spain, Sweden, Switzerland, Turkey and United Kingdom.

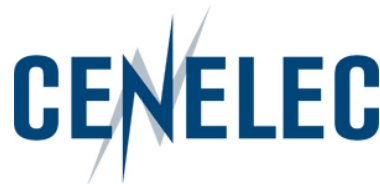

**CEN-CENELEC Management Centre:
Avenue Marnix 17, B-1000 Brussels**

Table of contents

Foreword	4
1 Scope	5
2 Normative references	6
3 Terms, definitions and abbreviated terms	7
3.1 Terms from other standards.....	7
3.2 Terms specific to the present standard	7
3.3 Abbreviated terms.....	7
4 Principles	8
5 Requirements	10
5.1 Preparatory conditions.....	10
5.1.1 Hazards, health and safety precautions	10
5.1.2 Preparation of samples	10
5.1.3 Facilities	12
5.1.4 Equipment.....	12
5.2 Test procedure	14
5.2.1 Preparation	14
5.2.2 Peel and pull-off test	14
5.2.3 Handling and packaging of tested samples	15
5.3 Acceptance criteria	15
5.4 Quality assurance.....	16
5.4.1 Data	16
5.4.2 Nonconformance.....	16
5.4.3 Calibration.....	16
5.4.4 Traceability	16
Annex A (normative) Test result sheet - DRD	17
Annex B (informative) Peel and pull-off test procedure	20
Annex C (informative) Fracture lines	22

Bibliography.....23

Figures

Figure 4-1 Test procedure flow diagram9
Figure 5-1: Side view of the test fixtures.....13

Figure A-1 : Example of test result sheet.....19
Figure C-1 : Schematic cross-section of a coated substrate showing various fracture
lines dependent on the weakest layer22

Foreword

This document (EN 16602-70-13:2015) has been prepared by Technical Committee CEN/CLC/TC 5 “Space”, the secretariat of which is held by DIN.

This standard (EN 16602-70-13:2015) originates from ECSS-Q-ST-70-13C Rev.1.

This European Standard shall be given the status of a national standard, either by publication of an identical text or by endorsement, at the latest by July 2015, and conflicting national standards shall be withdrawn at the latest by July 2015.

Attention is drawn to the possibility that some of the elements of this document may be the subject of patent rights. CEN [and/or CENELEC] shall not be held responsible for identifying any or all such patent rights.

This document has been prepared under a mandate given to CEN by the European Commission and the European Free Trade Association.

This document supersedes EN 14099:2001.

This document has been developed to cover specifically space systems and has therefore precedence over any EN covering the same scope but with a wider domain of applicability (e.g. : aerospace).

According to the CEN-CENELEC Internal Regulations, the national standards organizations of the following countries are bound to implement this European Standard: Austria, Belgium, Bulgaria, Croatia, Cyprus, Czech Republic, Denmark, Estonia, Finland, Former Yugoslav Republic of Macedonia, France, Germany, Greece, Hungary, Iceland, Ireland, Italy, Latvia, Lithuania, Luxembourg, Malta, Netherlands, Norway, Poland, Portugal, Romania, Slovakia, Slovenia, Spain, Sweden, Switzerland, Turkey and the United Kingdom.

1 Scope

This Standard details a test in which pressure-sensitive tapes are used to assess the suitability of, for example, coatings, paints, films and other thin materials, proposed for use on spacecraft and associated equipment.

Surface coatings, such as thermal control paints and corrosion protection coatings, are affected, both on the ground and after launch, by exposure to the environment.

It is therefore important that the adhesion of the coating to the relevant substrate remains at an acceptable level after exposure to the relevant environmental condition.

The following materials and assemblies are covered by this test method:

- organic coating, e.g. varnishes, paints and plastic films;
- metallic finishes on, for example, printed circuit boards, second-surface mirrors, thermal radiators, plastic films;
- adhesive layers;
- composite thin films;
- small assemblies, e.g. solar cells having attached glass covers.

This standard may be tailored for the specific characteristics and constraints of a space project in conformance with ECSS-S-ST-00.

2

Normative references

The following normative documents contain provisions which, through reference in this text, constitute provisions of this ECSS Standard. For dated references, subsequent amendments to, or revision of any of these publications do not apply. However, parties to agreements based on this ECSS Standard are encouraged to investigate the possibility of applying the more recent editions of the normative documents indicated below. For undated references, the latest edition of the publication referred to applies.

EN reference	Reference in text	Title
EN 16601-00-01	ECSS-S-ST-00-01	ECSS system – Glossary of terms
EN 16602-10-09	ECSS-Q-ST-10-09	Space product assurance – Nonconformance control system
EN 16602-20	ECSS-Q-ST-20	Space product assurance – Quality assurance
EN 16602-40	ECSS-Q-ST-40	Space product assurance – Safety
EN 16602-70-02	ECSS-Q-ST-70-02	Space product assurance – Thermal vacuum outgassing test for the screening of space materials

3

Terms, definitions and abbreviated terms

3.1 Terms from other standards

For the purpose of this Standard, the terms and definitions from ECSS-S-ST-00-01 apply, in particular for the following terms:

requirement

3.2 Terms specific to the present standard

3.2.1 batch

quantity produced at one operation.

NOTE One batch can be subdivided into several lots.

3.3 Abbreviated terms

For the purpose of this Standard, the abbreviated terms from ECSS-S-ST-00-01 and the following apply:

Abbreviation	Meaning
RH	relative humidity

4

Principles

This Standard details a test in which pressure-sensitive tapes are used to assess the suitability of, for example, coatings, paints, films and other thin materials, proposed for use on spacecraft and associated equipment.

This test has nine test steps as outlined in Figure 4-1.

Preparation: See 5.2.1

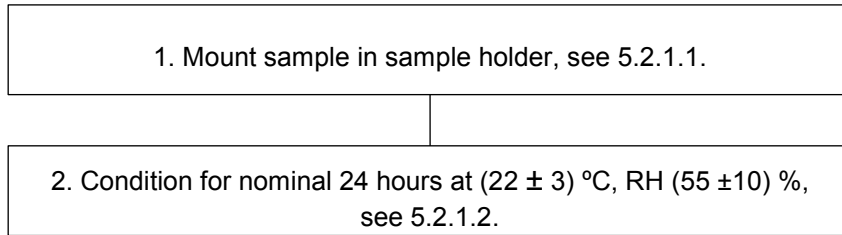

Peel and pull-off test: See 5.2.2

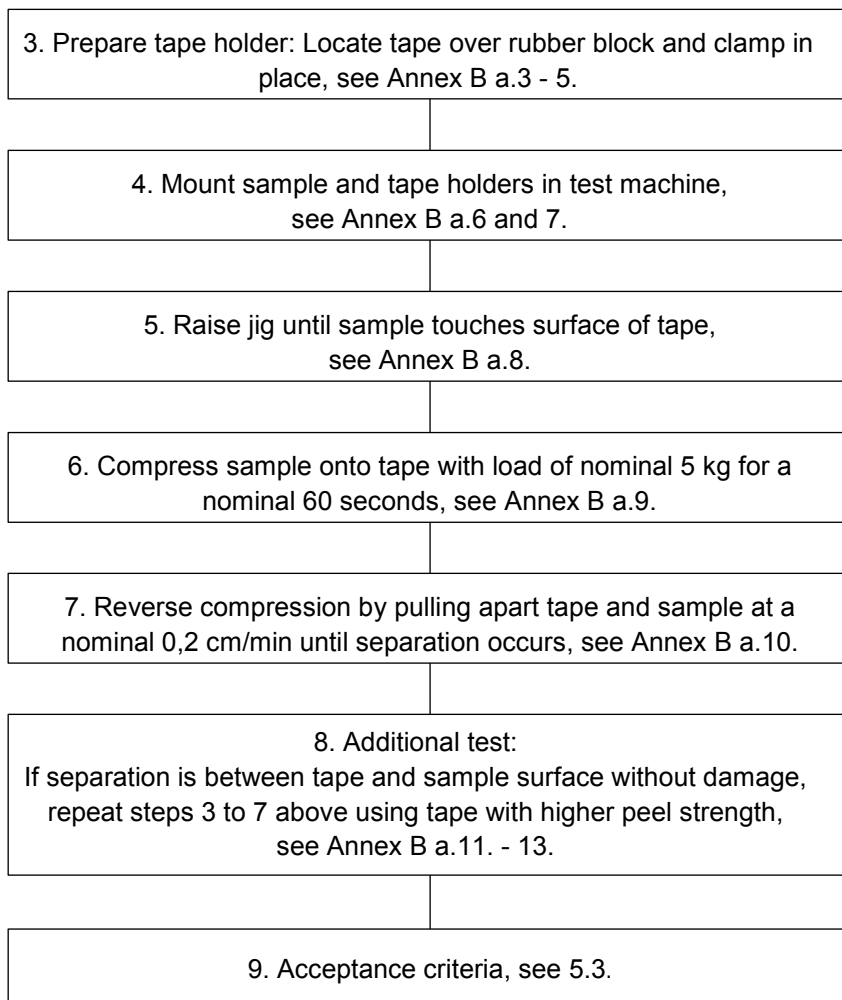

Figure 4-1 Test procedure flow diagram

5 Requirements

5.1 Preparatory conditions

5.1.1 Hazards, health and safety precautions

- a. The supplier shall identify, manage and process materials and parts with hazardous characteristics according to ECSS-Q-ST-40.
- b. The supplier shall keep the health and safety precautions according to the supplier's national safety regulations.

5.1.2 Preparation of samples

5.1.2.1 Configuration

- a. The supplier shall prepare the material samples according to the process specifications or manufacturer's data.
- b. The material samples shall be representative of batch variance.
- c. If it is not practicable to test completed assemblies, the supplier shall submit samples made from the same materials and by the same processes as those used in the manufacture of the assemblies.
- d. The sample for testing shall have clean flat surfaces which do not overlap the sample holder described in clause 5.1.4.
- e. The width of the test sample surface face shall be at least equal to the width of the tape used in the test procedure.
- f. The nominal tape width shall be 20 mm.
- g. The supplier shall specify the number of samples to be taken from a qualification batch, test programme, or production batch at the start of the test in conformance with the DRD in Annex A..
- h. The supplier shall test at least ten test samples.
- i. If it is not practicable to obtain test samples from the finished article, the supplier shall furnish bonded test samples for the test.

NOTE These samples are not used for any other purpose than the designated test.

- j. The supplier shall furnish a certificate of conformity for the purpose of traceability.

NOTE This certificate of conformity is delivered by the manufacturer in order to provide evidence that the product is compliant with the manufacturer's process.

- k. The supplier shall mark all test samples with identification to maintain traceability but in such a way as not to degrade the quality of the sample during testing.

5.1.2.2 Cleaning

- a. The supplier shall perform the same cleaning and other treatments of the sample as that applied to the finished article, which the sample is intended to represent, prior to integration into the spacecraft.
- b. The supplier shall not carry out further cleaning or other treatments.

5.1.2.3 Handling and storage

- a. The supplier shall handle the samples only with clean nylon or lint-free gloves.
- b. The supplier shall store the samples in a controlled area, with an ambient temperature of (22 ± 3) °C and relative humidity of (55 ± 10) %.
- c. The supplier shall shield coated surfaces from contact by using polyethylene or polypropylene bags or sheets.
- d. The supplier shall avoid physical damage by packing the polyethylene or polypropylene-wrapped workpieces in clean, dust- and lint-free material.
- e. The supplier shall label limited-life materials with their shelf lives and dates of manufacture, or date of delivery if date of manufacture is not known.

5.1.2.4 Identification

5.1.2.4.1 Materials

- a. The supplier shall identify materials submitted for testing in conformance to annex A of ECSS-Q-ST-70-02.

5.1.2.4.2 Assemblies

- a. The supplier shall identify assemblies submitted for testing, as a minimum, by:
 - 1. trade name and batch number;
 - 2. name of manufacturer or supplier through whom the purchase was made;
 - 3. configuration control status of the assembly.

5.1.3 Facilities

5.1.3.1 Cleanliness

- a. The work area shall be clean and free of dust.
- b. The supplier shall filter the air used for ventilation to prevent contamination of the sample.

5.1.3.2 Sample conditioning

- a. The supplier shall environmentally condition the sample for a nominal 24 hour period at (22 ± 3) °C with a relative humidity of (55 ± 10) %.

NOTE 1 The humidity requirement can be achieved either in a conditioning room, or by dessicators filled with silica gel or a saturated salt solution.

NOTE 2 A saturated salt solution of calcium nitrate gives approximately 51 % relative humidity at the testing temperature.

5.1.4 Equipment

5.1.4.1 Special equipment

- a. The supplier shall use the equipment as detailed in clauses 5.1.4.2 and 5.1.4.3.

5.1.4.2 Testing machine

- a. The supplier shall employ a power-driven machine capable of maintaining a specified constant rate of loading and able to be used for both tensile and compressive testing.
- b. The machine shall have a fixed or essentially stationary member supporting a load cell and the tape holder.
- c. A movable member shall carry the sample holder.
- d. The applied compressive and tensile loads, as measured and recorded, shall be accurate within 1 percent of the load.
- e. The rate of travel of the sample holder shall be at a nominal rate of 0,2 cm/min.

5.1.4.3 Fixtures

- a. The tape holder should be of a design similar to that depicted in Figure 5-1.
- b. The part shall be screwed into the fixed member of the testing machine or be located firmly on it.
- c. The supplier shall clamp a length of pressure-sensitive tape from one tape holder over the rubber block to the other tape holder.
- d. The surface of the pressure-sensitive tape in contact with the flat surface of the rubber block shall be $4 \text{ cm}^2 \pm 5 \%$.

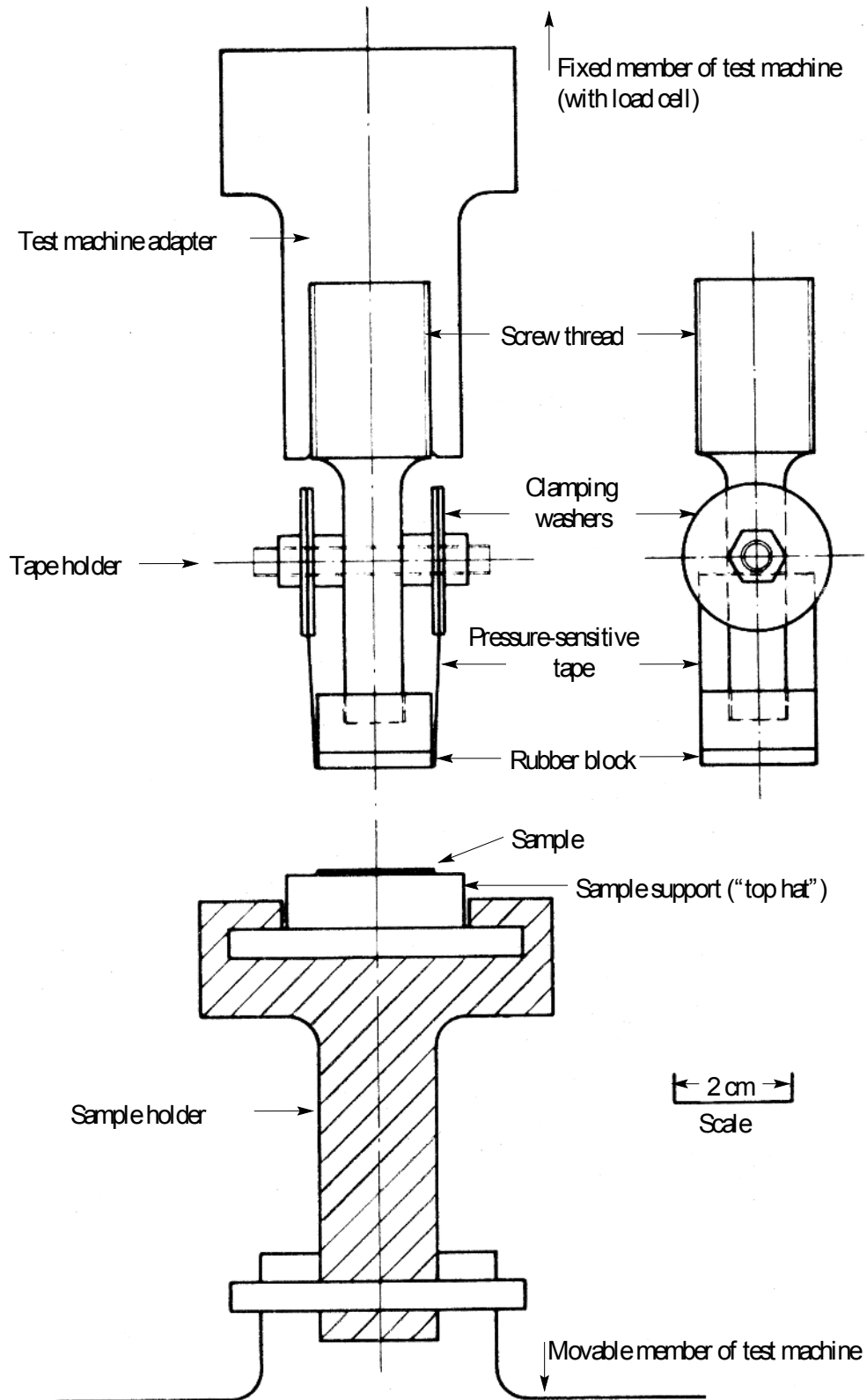

Figure 5-1: Side view of the test fixtures

5.1.4.4 Sample holder

- a. The sample holder shall be firmly located beneath the tape holder on the movable member of the testing machine.

NOTE 1 A suitable design is seen in Figure 5-1.

NOTE 2 This preferred system utilizes “top hat” supports onto which individual samples can be mechanically clamped or bonded in such a way that there is no relative movement between the support and the test sample at any time during the test cycle.

- b. In case a “top hat” sample support is used, it shall slide into a horizontal fixture slot in such a way that its top surface is parallel to and directly beneath the rubber face of the tape holder.

5.1.4.5 Peel adhesion tape

- a. The supplier shall employ a range of pressure-sensitive tapes for the tests with peel adhesion strengths of 220, 330, 440 and 670 g/cm, all with a tolerance of $\pm 10\%$.

5.2 Test procedure

5.2.1 Preparation

5.2.1.1 Mounting

- a. The supplier shall locate the test sample on the sample holder in conformance with the requirements stated in clause 5.1.4.3.
- b. If an adhesive bond is used between the sample and the sample support, this shall in no way interfere with the area under test.
- c. The supplier shall ensure that there is no physical or chemical interaction between any adhesive employed during sample preparation and the sample materials.

5.2.1.2 Conditioning

- a. The supplier shall condition the loaded sample support for a nominal 24 hours in conformance with the requirements stated in clause 5.1.3.2 before the test starts.

5.2.2 Peel and pull-off test

- a. The supplier should run the peel and pull-off test as described in Annex B.
- b. If the supplier uses a different procedure, the supplier shall submit it for customer approval.

5.2.3 Handling and packaging of tested samples

- a. The supplier shall apply the conditions specified in clause 5.1.2.3 unless other post test disposal instructions are given.

5.3 Acceptance criteria

- a. The supplier shall classify samples which have been tested and are not seen to be disturbed in any way by the processing described in clause 5.2.2 as having passed this test.
- b. The supplier shall examine samples in detail, which have been disturbed during the test sequence.
- c. The supplier shall carry out a visual examination for sample defects at $\times 7$ magnification.
- d. In case defects are detected at $\times 7$ magnification, the supplier should use higher magnifications during further analysis for locating microscopic defects on any fracture surfaces.

- e. The supplier shall report defects and the appearance of the fracture.

NOTE 1 Defects for instance can be air bubbles or material inclusions.

NOTE 2 Appearance of the fracture for instance can be rough, ductile, smooth or brittle.

- f. The supplier shall state the particular material or interface along which the fracture path has propagated through the test sample.

NOTE This can be wholly or partly an adhesion fracture, a cohesive separation or an adherent fracture as schematically drawn in Figure C-1.

- g. The supplier shall take a photographic record of the tested samples at appropriate level of magnification.

NOTE Typical topographical features are recorded at $\times 2$, $\times 20$, $\times 50$, $\times 100$, $\times 250$, $\times 500$ or $\times 1000$ magnifications.

- h. The supplier shall agree with the customer on the granularity level of failure analysis to be performed on failed samples, prior to the test.

- i. The supplier shall perform the failure analysis as agreed with the customer.

NOTE This failure analysis can include metallographic studies, chemical analysis or scanning electronic microscopy.

5.4 Quality assurance

5.4.1 Data

- a. The supplier shall retain the quality records for at least ten years or in conformance with project business agreement requirements, and in conformance with the Test result sheet - DRD in Annex A.

NOTE Example of such quality records are logbooks.

5.4.2 Nonconformance

- a. The supplier shall disposition any nonconformance which is observed in respect of the test process in conformance with the quality assurance requirements specified in ECSS-Q-ST-10-09.

5.4.3 Calibration

- a. The supplier shall use only measuring equipment calibrated to traceable reference standard.
- b. The supplier shall record any suspected or actual equipment failure as a project nonconformance report according to ECSS-Q-ST-20.

NOTE This is to ensure that previous results can be examined to ascertain whether or not re-inspection and retesting is required.

- c. The supplier shall notify the customer of the nonconformance details.

5.4.4 Traceability

- a. The supplier shall maintain traceability throughout the process from incoming inspection to final test, including details of test equipment and personnel employed in performing the task.

Annex A (normative)

Test result sheet - DRD

A.1 DRD identification

A.1.1 Requirement identification and source document

This DRD is called from ECSS-Q-ST-70-13, requirement 5.4.1a.

A.1.2 Purpose and objective

The purpose of the test result sheet is to summarize the test results.

A.2 Expected response

A.2.1 Scope and content

- a. The test result sheet shall contain the trade names of the materials under test.
- b. The test result sheet shall contain the batch numbers of the materials under test.
- c. The test result sheet shall contain name of manufacturer or supplier through whom the purchase was made.
- d. The test result sheet shall contain summary of the preparation and conditioning schedule.

NOTE This can be for instance the mixing proportions, coating thickness, cure time and temperature, post-cure or cleaning procedure.

- e. The test result sheet shall contain details of the testing room environment conditions and test equipment.
- f. The test result sheet shall contain details of the test parameters outlined in Annex B.

NOTE This also includes any variation in testing environment conditions.

- g. The test result sheet shall contain details of equipment used for visual, mechanical, chemical and physical property measurement or inspection, as outlined in Annex B and test specifications where they exist.
- h. The test result sheet shall contain the number of sample tests.
- i. The test result sheet shall contain the results of the values obtained for peel or pull-off strength.
- j. The test result sheet shall contain the peel strength indicated by the manufacturer of the pressure-sensitive tape used.
- k. The test result sheet shall contain the results of any failure analysis carried out according to clause 5.3.
- l. The test result sheet shall contain the mode of fracture and any photographic records.

NOTE An indication of the various fracture line is given in Figure C-1.

- m. In case of failures, the test result sheet shall contain the following details of failure mode:
 - 1. deficient design;
 - 2. poor workmanship;
 - 3. wrong fabrication or application procedure;
 - 4. wrong choice of materials;
 - 5. others.

A.2.2 Special remarks

- a. The supplier may use the template given in Figure A-1.

Materials Section, Product Assurance Division, ESTEC				
Sample details				
1. Description and history of sample:				
2. Trade name:				
2. Batch number:				
4. Coating or finish material manufacturer:				
5. Supplier through whom material is purchased:				
6. Coating or finish prepared by:				
7. Summary of preparation schedule:				
8. Number of samples submitted:				
9. Criteria for test, e.g. lowest acceptable peel or pull-off strength:				
10. Project and cost code number:				
Date:		Originator:		Telephone:
Test results				
11. Test equipment:				
12. Test temperature: °C			13. Relative humidity: %	
14. Speed of testing: cm/min				
15. Sample number	16. Peel strength of tape employed *	17. Peel or pull-off strength of sample **	18. Mode of fracture, see Figure 3	19. Further examinations
Conclusions				
Date:		Test engineer:		Approval:
* as indicated by manufacturer, the peel strength of tape when sample separation commenced is underlined. ** from chart record				

Figure A-1: Example of test result sheet

Annex B (informative)

Peel and pull-off test procedure

- a. The supplier should perform the peel and pull-off test according to the following procedure:
1. conduct the test as soon as possible after the loaded sample support has been removed from the conditioning atmosphere;
 2. conduct the test under the same environment conditions;
 3. prepare the tape holder by hand;
 4. fix a length of the lowest peel-strength tape in such a way that it follows the contour of the rubber block without creases, folds, visible surface flaws or slack spots;
 5. secure the two free ends of the tape and stretches the tape so as to leave no slack;
 6. locate the tape holder and sample support holder on the fixed member and the movable member of the machine respectively;
 7. position the sample under test, being bonded onto the sample support, in the support holder in such a way as to be directly beneath the rubber block of the tape holder;
 8. then raise the lower adjustable member of the machine so that the surface of the test sample comes into contact with the pressure-sensitive tape;
 9. apply a compressive load of a nominal 5 kg for a nominal 60 s, so as to ensure that the pressure-sensitive tape is in positive contact with the sample surface;
 10. move away the movable member of the machine from the test sample at a constant rate of a nominal 0,2 cm/min until such time as there is complete detachment between the tape and the sample;
 11. visually examine the parted surfaces at a magnification of between $\times 3$ and $\times 7$;
 12. With this examination, determine whether separation has occurred cleanly between the tape and the sample surface or whether the surface finish has delaminated from the substrate of the sample;
 13. In the case where separation has occurred cleanly between the tape and the sample surface, remove the tape fixture from the machine and replace the used tape by a new length of tape having a greater peel strength;

14. recommence the procedure from step 3;
15. Continue the procedure until either delaminating of the surface finish occurs, or the tape having the maximum peel strength given at clause 5.1.4.5 has been employed.

Annex C (informative) Fracture lines

Figure C-1 represents an schematic cross-section of a coated substrate showing various fracture lines dependent on the weakest layer.

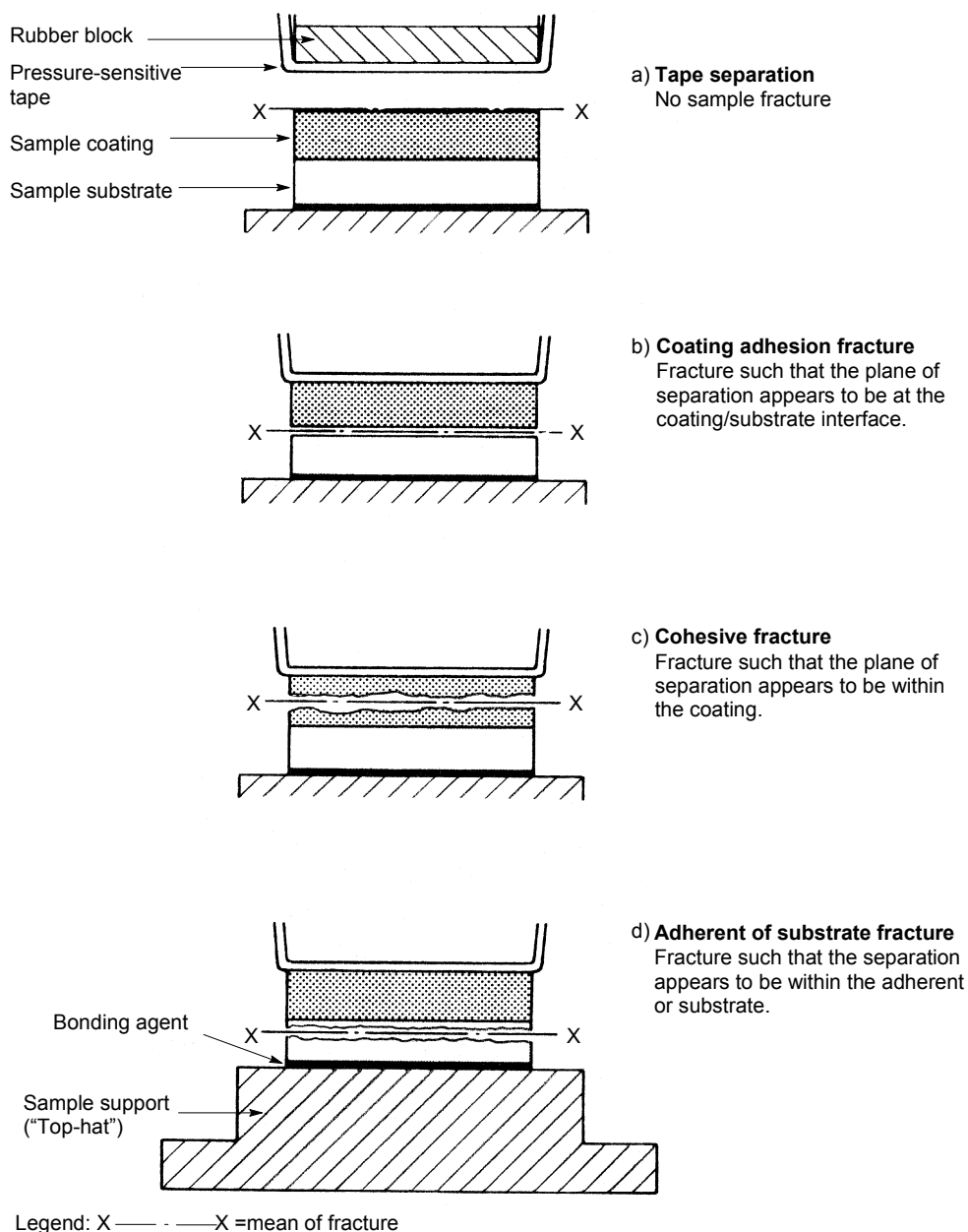

Figure C-1: Schematic cross-section of a coated substrate showing various fracture lines dependent on the weakest layer

Bibliography

EN reference	Reference in text	Title
EN 16601-00	ECSS-S-ST-00	ECSS system – Description, implementation and general requirements

British Standards Institution (BSI)

BSI is the national body responsible for preparing British Standards and other standards-related publications, information and services.

BSI is incorporated by Royal Charter. British Standards and other standardization products are published by BSI Standards Limited.

About us

We bring together business, industry, government, consumers, innovators and others to shape their combined experience and expertise into standards-based solutions.

The knowledge embodied in our standards has been carefully assembled in a dependable format and refined through our open consultation process. Organizations of all sizes and across all sectors choose standards to help them achieve their goals.

Information on standards

We can provide you with the knowledge that your organization needs to succeed. Find out more about British Standards by visiting our website at bsigroup.com/standards or contacting our Customer Services team or Knowledge Centre.

Buying standards

You can buy and download PDF versions of BSI publications, including British and adopted European and international standards, through our website at bsigroup.com/shop, where hard copies can also be purchased.

If you need international and foreign standards from other Standards Development Organizations, hard copies can be ordered from our Customer Services team.

Subscriptions

Our range of subscription services are designed to make using standards easier for you. For further information on our subscription products go to bsigroup.com/subscriptions.

With **British Standards Online (BSOL)** you'll have instant access to over 55,000 British and adopted European and international standards from your desktop. It's available 24/7 and is refreshed daily so you'll always be up to date.

You can keep in touch with standards developments and receive substantial discounts on the purchase price of standards, both in single copy and subscription format, by becoming a **BSI Subscribing Member**.

PLUS is an updating service exclusive to BSI Subscribing Members. You will automatically receive the latest hard copy of your standards when they're revised or replaced.

To find out more about becoming a BSI Subscribing Member and the benefits of membership, please visit bsigroup.com/shop.

With a **Multi-User Network Licence (MUNL)** you are able to host standards publications on your intranet. Licences can cover as few or as many users as you wish. With updates supplied as soon as they're available, you can be sure your documentation is current. For further information, email bsmusales@bsigroup.com.

BSI Group Headquarters

389 Chiswick High Road London W4 4AL UK

Revisions

Our British Standards and other publications are updated by amendment or revision.

We continually improve the quality of our products and services to benefit your business. If you find an inaccuracy or ambiguity within a British Standard or other BSI publication please inform the Knowledge Centre.

Copyright

All the data, software and documentation set out in all British Standards and other BSI publications are the property of and copyrighted by BSI, or some person or entity that owns copyright in the information used (such as the international standardization bodies) and has formally licensed such information to BSI for commercial publication and use. Except as permitted under the Copyright, Designs and Patents Act 1988 no extract may be reproduced, stored in a retrieval system or transmitted in any form or by any means – electronic, photocopying, recording or otherwise – without prior written permission from BSI. Details and advice can be obtained from the Copyright & Licensing Department.

Useful Contacts:

Customer Services

Tel: +44 845 086 9001

Email (orders): orders@bsigroup.com

Email (enquiries): cservices@bsigroup.com

Subscriptions

Tel: +44 845 086 9001

Email: subscriptions@bsigroup.com

Knowledge Centre

Tel: +44 20 8996 7004

Email: knowledgecentre@bsigroup.com

Copyright & Licensing

Tel: +44 20 8996 7070

Email: copyright@bsigroup.com



...making excellence a habit.™