

BS EN 16584-1:2017



BSI Standards Publication

# Railway applications — Design for PRM use — General requirements

Part 1: Contrast

**National foreword**

This British Standard is the UK implementation of EN 16584-1:2017.

The UK participation in its preparation was entrusted to Technical Committee RAE/1/-/15, Railway Applications - People with Reduced Mobility.

A list of organizations represented on this committee can be obtained on request to its secretary.

This publication does not purport to include all the necessary provisions of a contract. Users are responsible for its correct application.

© The British Standards Institution 2017.

Published by BSI Standards Limited 2017

ISBN 978 0 580 74358 0

ICS 11.180.01; 45.020

**Compliance with a British Standard cannot confer immunity from legal obligations.**

This British Standard was published under the authority of the Standards Policy and Strategy Committee on 31 January 2017.

**Amendments/corrigenda issued since publication**

Date	Text affected
------	---------------

---

EUROPEAN STANDARD

**EN 16584-1**

NORME EUROPÉENNE

EUROPÄISCHE NORM

January 2017

ICS 11.180.01; 45.020

English Version

## Railway applications - Design for PRM use - General requirements - Part 1: Contrast

Applications ferroviaires - Conception destinée à l'usage par les PMR - Exigences générales - Partie 1: Contraste

Bahnanwendungen - Gestaltung für die Nutzung durch PRM - Allgemeine Anforderungen - Teil 1: Kontrast

This European Standard was approved by CEN on 10 September 2016.

CEN members are bound to comply with the CEN/CENELEC Internal Regulations which stipulate the conditions for giving this European Standard the status of a national standard without any alteration. Up-to-date lists and bibliographical references concerning such national standards may be obtained on application to the CEN-CENELEC Management Centre or to any CEN member.

This European Standard exists in three official versions (English, French, German). A version in any other language made by translation under the responsibility of a CEN member into its own language and notified to the CEN-CENELEC Management Centre has the same status as the official versions.

CEN members are the national standards bodies of Austria, Belgium, Bulgaria, Croatia, Cyprus, Czech Republic, Denmark, Estonia, Finland, Former Yugoslav Republic of Macedonia, France, Germany, Greece, Hungary, Iceland, Ireland, Italy, Latvia, Lithuania, Luxembourg, Malta, Netherlands, Norway, Poland, Portugal, Romania, Serbia, Slovakia, Slovenia, Spain, Sweden, Switzerland, Turkey and United Kingdom.



EUROPEAN COMMITTEE FOR STANDARDIZATION  
COMITÉ EUROPÉEN DE NORMALISATION  
EUROPÄISCHES KOMITEE FÜR NORMUNG

**CEN-CENELEC Management Centre: Avenue Marnix 17, B-1000 Brussels**

<b>Contents</b>	<b>Page</b>
European foreword.....	4
Introduction .....	5
<b>1</b> Scope .....	<b>6</b>
<b>2</b> Normative references .....	<b>7</b>
<b>3</b> Terms and definitions .....	<b>7</b>
<b>4</b> Symbols and abbreviations .....	<b>11</b>
<b>5</b> Requirements and assessment.....	<b>11</b>
5.1 General.....	11
5.2 Infrastructure .....	12
5.2.1 Obstacle-free routes.....	12
5.2.2 Doors and entrances .....	12
5.2.3 Transparent obstacles.....	14
5.2.4 Furniture and free standing devices .....	14
5.2.5 Handrails.....	14
5.2.6 Platform danger area and edge of platform .....	14
5.2.7 End of platform .....	15
5.3 Rolling stock.....	15
5.3.1 Seats .....	15
5.3.2 Doors.....	17
5.3.3 Exterior doors .....	18
5.3.4 Interior doors .....	21
5.3.5 Toilets (standard and universal).....	22
5.3.6 Customer Information .....	24
5.3.7 Height changes .....	25
5.3.8 Handrails.....	25
5.3.9 Access/egress steps.....	25
5.3.10 Call for aid devices .....	26
5.4 Boarding aids (ramps, lifts and bridging plates) for infrastructure and rolling stock.....	27
<b>6</b> Methodologies for assessing contrast.....	<b>28</b>
6.1 General.....	28
6.2 Establishing LRVs .....	28
6.2.1 General.....	28
6.2.2 Method of establishing LRV .....	28
6.2.3 Specific assessment criteria for stainless steel .....	34
6.3 Method of assessing contrast with LRVs established (as in 6.2).....	35
6.3.1 General requirements for contrast.....	35
6.3.2 Specific requirements for contrast on signage.....	35
6.3.3 Durability of contrast.....	35
6.3.4 Specific requirements for electronic displays .....	36
Annex A (normative) Contrast charts .....	37
A.1 General.....	37
A.2 Worked examples for contrast.....	38

A.3	Self contrasting bands .....	41
<b>Annex B (normative) Contrast for doors and transparent obstacles .....</b>		<b>42</b>
B.1	General.....	42
B.2	Exterior doors .....	42
B.3	Case 1: If the window is less than or equal to 40 % of the visible door leaf.....	42
B.4	Case 2: If the window is greater than 40 % of the visible door leaf.....	44
B.5	Case 3: Alternative if the door leaf is not coloured to contrast with the bodyside .....	45
B.6	Markings for interior doors or transparent obstacles .....	46
<b>Annex C (normative) Effective contrast calculation for displays.....</b>		<b>49</b>
C.1	Illuminated displays.....	49
C.2	Back-lit and/or self-lit displays .....	49
<b>Annex D (normative) EC verification.....</b>		<b>51</b>
D.1	Interoperability constituents .....	51
D.1.1	Conformity assessment.....	51
D.1.2	Application of modules .....	51
D.2	Subsystems .....	52
D.2.1	EC verification (general).....	52
D.2.2	Procedures for EC verification of a subsystem (modules) .....	52
<b>Annex E (normative) Summary of testing requirements.....</b>		<b>54</b>
<b>Annex F (informative) Supporting information from published documents .....</b>		<b>56</b>
F.1	General.....	56
F.2	CIE Publication 196:2011 CIE Guide to Increasing Accessibility in Light and Lighting.....	56
F.3	ADA Accessibility Guidelines for Buildings and Facilities.....	56
F.4	BS 8300 2009 Design of buildings and their approaches to meet the needs of disabled people – Code of practice.....	56
<b>Annex ZA (informative) Relationship between this European Standard and the Essential Requirements of EU Directive 2008/57/EC aimed to be covered.....</b>		<b>58</b>
<b>Bibliography.....</b>		<b>60</b>

## European foreword

This document (EN 16584-1:2017) has been prepared by Technical Committee CEN/TC 256 “Railway applications”, the secretariat of which is held by DIN.

This European Standard shall be given the status of a national standard, either by publication of an identical text or by endorsement, at the latest by July 2017, and conflicting national standards shall be withdrawn at the latest by July 2017.

Attention is drawn to the possibility that some of the elements of this document may be the subject of patent rights. CEN [and/or CENELEC] shall not be held responsible for identifying any or all such patent rights.

This document has been prepared under a mandate given to CEN by the European Commission and the European Free Trade Association, and supports essential requirements of EU Directive 2008/57/EC.

For relationship with EU Directive 2008/57/EC, see informative Annex ZA, which is an integral part of this document.

According to the CEN/CENELEC Internal Regulations, the national standards organizations of the following countries are bound to implement this European Standard: Austria, Belgium, Bulgaria, Croatia, Cyprus, Czech Republic, Denmark, Estonia, Finland, Former Yugoslav Republic of Macedonia, France, Germany, Greece, Hungary, Iceland, Ireland, Italy, Latvia, Lithuania, Luxembourg, Malta, Netherlands, Norway, Poland, Portugal, Romania, Serbia, Slovakia, Slovenia, Spain, Sweden, Switzerland, Turkey and the United Kingdom.

## Introduction

This document is part of a suite of four 'Design for PRM use' standards that have in total nine parts:

- EN 16584 is a standard that covers both infrastructure and rolling stock — Railway applications — Design for PRM use — General requirements:
  - Part 1: Contrast (EN 16584-1)
  - Part 2: Information (EN 16584-2)
  - Part 3: Optical and friction characteristics (EN 16584-3)
- EN 16585 is a standard that covers rolling stock — Railway applications — Design for PRM use — Equipment and components on board rolling stock:
  - Part 1: Toilets (EN 16585-1)
  - Part 2: Elements for sitting, standing and moving (EN 16585-2)
  - Part 3: Clearways and internal doors (EN 16585-3)
- EN 16586 is a standard that covers rolling stock — Railway applications — Design for PRM use — Accessibility of persons with reduced mobility to rolling stock:
  - Part 1: Steps for access and egress (EN 16586-1)
  - Part 2: Boarding aids (EN 16586-2)
- EN 16587 is a standard that covers infrastructure — Railway applications — Design for PRM use — Requirements for obstacle free routes for infrastructure.

These standards aim to clarify the requirements (with clear and consistent terms and definitions) and to define the associated criteria and, where appropriate, methodologies to allow a clear pass/fail assessment.

## 1 Scope

This European Standard describes the specific 'Design for PRM use' requirements applying to both infrastructure and rolling stock and the assessment of those requirements. The following applies to this standard:

- The definitions and requirements describe specific aspects of 'Design for PRM use' required by persons with disabilities and persons with reduced mobility as defined in the PRM TSI.
- This standard defines elements that are universally valid for obstacle free travelling including lighting, contrast, tactile feedback, transmission of visual and acoustic information. The definitions and requirements of this standard cover the infrastructure and rolling stock applications.
- This standard only refers to aspects of accessibility for PRM passengers it does not define non PRM related requirements and definitions.
- This standard assumes that the infrastructure or rolling stock is in its defined operating condition.
- Where minimum or maximum dimensions are quoted these are absolute NOT nominal requirements.

The 'General requirements' standard is written in three parts:

- This document is Part 1 and contains
  - contrast;
- Part 2 contains
  - spoken information;
  - written information;
  - tactile information;
  - pictograms;
- Part 3 contains
  - lighting;
  - low reflective properties;
  - transparent obstacles;
  - slip resistance.



## 2 Normative references

The following documents, in whole or in part, are normatively referenced in this document and are indispensable for its application. For dated references, only the edition cited applies. For undated references, the latest edition of the referenced document (including any amendments) applies.

EN 10088-2:2014, *Stainless steels - Part 2: Technical delivery conditions for sheet/plate and strip of corrosion resisting steels for general purposes*

EN 13272, *Railway applications - Electrical lighting for rolling stock in public transport systems*

EN 16584-2:2017, *Railway applications — Design for PRM use — General requirements — Part 2: Information*

EN 16584-3, *Railway applications — Design for PRM use — General requirements — Part 3: Optical and friction characteristics*

prEN 16586-1:2013, *Railway applications — Design for PRM use — Accessibility of persons with reduced mobility to rolling stock — Part 1: Steps for access and egress*

prEN 16587:2013, *Railway applications — Design for PRM use — Requirements for obstacle free routes for infrastructure*

ISO 17398, *Safety colours and safety signs — Classification, performance and durability of safety signs*

ISO 21542:2011, *Building construction — Accessibility and usability of the built environment*

## 3 Terms and definitions

For the purposes of this document, the following terms and definitions apply.

### 3.1

#### **bezel**

raised area that surrounds a pressel as part of a pushbutton

### 3.2

#### **character height**

vertical size of uppercase letters or numbers

### 3.3

#### **contrast**

perception of a difference visually between one surface or element of a building/rail vehicle and another by reference to their light reflectance values (LRV) or luminance values

Note 1 to entry: See BS 8300:2009+A1:2010 for further information

### 3.4

#### **customer information**

visual and spoken information other than information intended only for staff

### 3.5

#### **first step**

step that is the first step for a passenger to use, to overcome a height change

Note 1 to entry: For the external access/egress steps this will normally be the step that is closest to the platform edge (it may be a fixed or a moveable step), therefore this is the first step when boarding and the last step when alighting.

Note 2 to entry: In the context of steps for internal height changes (other than the external access/egress steps) this means the first usable step when ascending and the edge of the walking floor when descending

### **3.6**

#### **fixed longitudinal seat**

passenger seat which is installed along the body side (not foldable or intended to tip up) facing perpendicular to the direction of travel

### **3.7**

#### **free standing device**

element or item within the confines of the station and on platforms, whether fixed or removable, that is not part of the station structures

Note 1 to entry: Elements that are not included in this definition are lifts, external staircases, walls, any suspended devices, (the lower most part of which is more than 2 100 mm above the walking floor) and items that have a dimension greater (perpendicular to the walking direction) than 2 000 mm (e.g. fence, waiting shelter)

### **3.8**

#### **halo**

illuminated ring surrounding a pressel, not necessarily continuous

### **3.9**

#### **hue and chroma**

attributes of a colour which include its hue (frequency) and saturation (the dominant wavelength of a colour) also known as "chromaticity"

Note 1 to entry: A colour system (colour space, colour model) defines colour by hue, saturation and brightness. The hue is the predominant colour, the saturation is the colour intensity from achromatic (colourless) to the pure colour and the value (result) is the brightness from light to dark

### **3.10**

#### **innovative solution**

technological progression that results in a solution that does not comply with the specification set out in Clause 5 of this standard or for which there are no assessment methods

Note 1 to entry: An innovative solution (Article 6 Commission Regulation (EU) No 1300/2014) may only be used following a positive opinion from the European Commission

### **3.11**

#### **last step**

final step for an ascending passenger to use to overcome a height change, forming the edge of the walking floor

### 3.12

#### **Light Reflectance Value (LRV)**

total quantity of visible light that is reflected by a surface at all wavelengths and directions when illuminated by a light source

Note 1 to entry: The measured range of LRV is between 0 and 100 points.

Note 2 to entry: See Annex F for further information.

### 3.13

#### **low reflective properties**

characteristics that reduce reflection of light from a surface

### 3.14

#### **pictogram**

graphical symbol, diagram or figure with a particular meaning which directly represents or conveys its meaning independently of language through a pictorial representation of a physical object, action or character

Note 1 to entry: Refer to ISO 7001:2007, ISO/TR 7239 and ISO 9186 (all parts) for rules regarding graphical symbols and frames

### 3.15

#### **pressel**

surface of the pushbutton which is pressed in order to activate the pushbutton

### 3.16

#### **routeing information**

information, used by passengers to guide them on their journey, a guide as to which route to take to get to a required destination or facility and changes along that journey

Note 1 to entry: This can be temporary information to an event e.g. exhibition or sporting event but NOT any form of commercial advertising.

### 3.17

#### **spoken information**

information audibly communicated in words

Note 1 to entry: This can be direct, pre-recorded or synthesized information

### 3.18

#### **station**

any form of infrastructure where a train operates and passengers can board or alight in normal operation

### 3.19

#### **station building**

building or structure within the confines of the station in areas for use by passengers which can be open at different times to the overall station

Note 1 to entry: This does not include other commercial structures that are not essential for travel

**3.20**

**tactile**

information that is understood through the physical sense of touch

Note 1 to entry: Tactile signs, controls, symbols, pictograms, guide path and Braille or raised characters are a physical means by which tactile information is provided

**3.21**

**transparent obstacle**

obstacle that allows objects or images to be seen as if there were no intervening material, seen through with a level of clarity

Note 1 to entry: Transparency in this standard is when an obstacle allows at least 50 % direct light transmission

**3.22**

**universal toilet**

toilet designed to be used by all passengers including passengers in wheelchairs

**3.23**

**visual acuity**

clearness or acuteness of vision

**3.24**

**visual information**

written information, pictograms and markings

**3.25**

**written information**

information visually communicated in words, letters and numerals, excluding pictograms and markings

## 4 Symbols and abbreviations

**Table 1 — Abbreviations**

Abbreviation	Designation
CIE	Commission Internationale de l'Eclairage.
EN	European Standard
ISO	the International Organization for Standardization
LRV	Light Reflectance Value
NCS	Natural Colour System
PRM	Persons with disabilities and persons with reduced mobility
TSI	Technical Specification for Interoperability
UV	Ultraviolet light

**Table 2 — Symbols**

Symbol	Designation	Unit
$E_F$	brightness of extraneous light	
$k$	unit of contrast	
K	correlated colour temperature (of a light source)	Kelvin
$K_{eff}$	the effective contrast	
$L$	unit of luminance in candela per square metre	cd/m <sup>2</sup>
$L_0$	the LRV of the object	
$L_1$	the luminous densities for self-lit displays when off	
$L_2$	the luminous densities for self-lit displays when on	
$L_c$	the LRV of the character (signage only)	
$L_F$	the luminance generated by extraneous light	
$L_h$	the LRV of the background or adjacent surface	
lx	illuminance	lux
m	length	metre
mm	length	millimetre
nm	length (one billionth of a metre)	nanometre
$\rho_A$	reflectance value of surface of the display	

## 5 Requirements and assessment

### 5.1 General

Assessment of the requirements identified in Clause 5 shall be according to Annex D and Annex E. Where additional assessment criteria apply, these will be identified against the relevant clause.

The fonts, symbols and pictograms used for visual information shall contrast with their background.

- Contrast shall be assessed according to Annex A.

All dimensions in the figures are in millimetres (mm) unless otherwise stated.

## **5.2 Infrastructure**

### **5.2.1 Obstacle-free routes**

#### **5.2.1.1 Horizontal circulation**

Where thresholds are installed on a horizontal route, they shall contrast with the surrounding floor and shall not be higher than 25 mm.

- Contrast shall be assessed according to Annex A.
- Assessment of height shall be according to prEN 16587:2013.

#### **5.2.1.2 Vertical circulation**

As a minimum the first and last steps of staircases shall be indicated by a contrasting band.

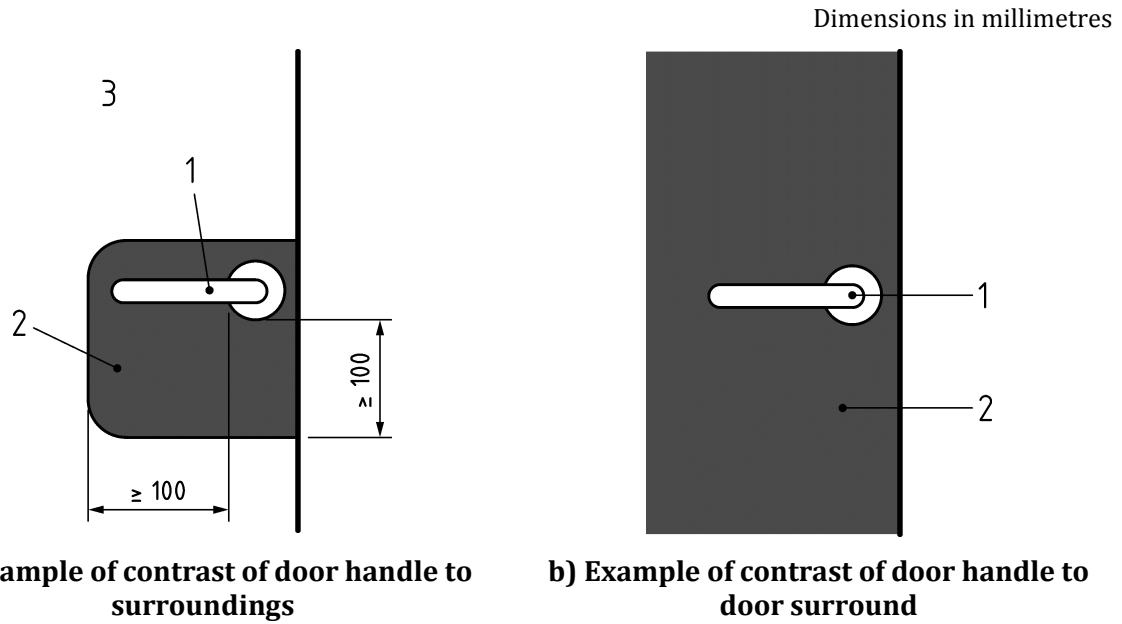
- Contrast shall be assessed according to Annex A.

### **5.2.2 Doors and entrances**

This clause applies to all doors and entrances that are on obstacle-free routes according to prEN 16587:2013 with the exception of doors giving access to the toilets which are not dedicated to persons with disabilities and persons with reduced mobility.

If pushbuttons or other control devices are provided for operation of doors then each pushbutton or device shall contrast with its surroundings:

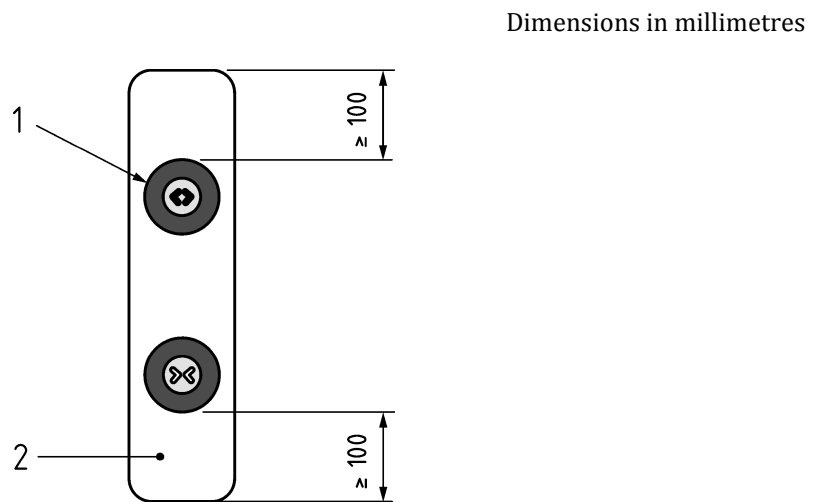
- contrast shall be assessed according to Annex A;
- the surroundings shall be defined as 100 mm in at least two directions (at least 90 degrees apart) from the edge of the control bezel outwards over at least the full width of that control (the resultant area shall be at least 20 000 mm<sup>2</sup>) see Figures 1a and 1b;
- the control for the doors if it is a pushbutton shall be assessed as the pressel, the illuminating halo and the bezel combined which shall have a minimum area of 5 000 mm<sup>2</sup>. See Figure 2.



**Key**

- 1 door control device (handle)
- 2 a) surroundings (may be the whole door or minimised as dimensioned)  
b) surroundings (door)
- 3 the rest of the door when localized contrast is used

**Figure 1 — Examples of contrast of door handles**



**Key**

- 1 door control device (for example pushbutton)
- 2 contrasting surface, min. 20 000 mm<sup>2</sup>, min. 100 mm in at least two directions from a cluster of pushbuttons

**Figure 2 — Example of contrast of pushbuttons to background**

### 5.2.3 Transparent obstacles

Transparent obstacles on or along the routes used by passengers, consisting of glass doors or transparent walls, shall be marked. These markings shall highlight the transparent obstacles.

- Assessment shall be according to ISO 21542:2011 or appropriate national or regional standards.

These markings shall:

- i. contrast with the background against which they are viewed.
  - Contrast shall be assessed according to Annex A.

NOTE 1 The background is the area behind the obstacle as viewed in the direction of passenger movement.

or

- ii. consist of two separate colours that have a minimum difference in LRV of 60 points and comply with requirements in B.3.

NOTE 2 60 point difference in LRV achieves contrast against varying lighting conditions and backgrounds.

- iii. if the obstacle can be approached from two different directions the requirement shall be met on each side that the obstacle can be approached.

NOTE 3 These markings are not required along transparent walls if passengers are protected from impact by other means – for example, by handrails or continuous benches.

### 5.2.4 Furniture and free standing devices

All items of furniture and free standing devices at stations shall contrast with their background:

- contrast shall be assessed according to Annex A;
- assessment shall be according to ISO 21542:2011, 7.3 or appropriate national or regional standards.

### 5.2.5 Handrails

Handrails shall contrast with the surrounding wall colours:

- contrast shall be assessed according to Annex A.

NOTE The surrounding wall is the surface immediately behind the handrail.

Where used, stainless steel handrails shall meet the appropriate requirements of Clause 6.

### 5.2.6 Platform danger area and edge of platform

- 1) the danger area of a platform commences at the rail side edge of the platform and is defined as the area where passengers are not allowed to stand when trains are passing or arriving.
  - the danger area shall be according to National Rules;



- 2) the boundary of the danger area, furthest from the rail side edge of the platform, shall have visual marking and tactile walking surface indicators.
  - The tactile walking surface indicators shall be according to EN 16584-2;
- 3) the visual marking shall be a contrasting, slip resistant, warning line with a minimum width of 100 mm:
  - contrast shall be assessed according to Annex A;
  - slip resistance shall be assessed according to EN 16584-3;
- 4) the width shall be measured horizontally and perpendicular to the track;

NOTE 1 The surface, with which the warning line shall contrast, is the immediately adjacent area of the platform.
- 5) the rail side edge of the platform shall contrast with the darkness of the gap;
- 6) the LRV of the rail side edge of the platform shall be defined and measured according to Clause 6;
- 7) The LRV of the rail side edge of the platform shall be greater than 30 points;

NOTE 2 As it is the gap that is referred to, it means that a train is present and casting a shadow so the gap is therefore dark and assumed to have an LRV of 0.
- 8) If the gap is illuminated by artificial lighting from below, 30 points difference to that gap shall be demonstrated;

### 5.2.7 End of platform

Where there is no physical barrier that prevents public access, then the end of the platform shall have a visual marking and tactile walking surface indicators with an attention pattern indicating a hazard.

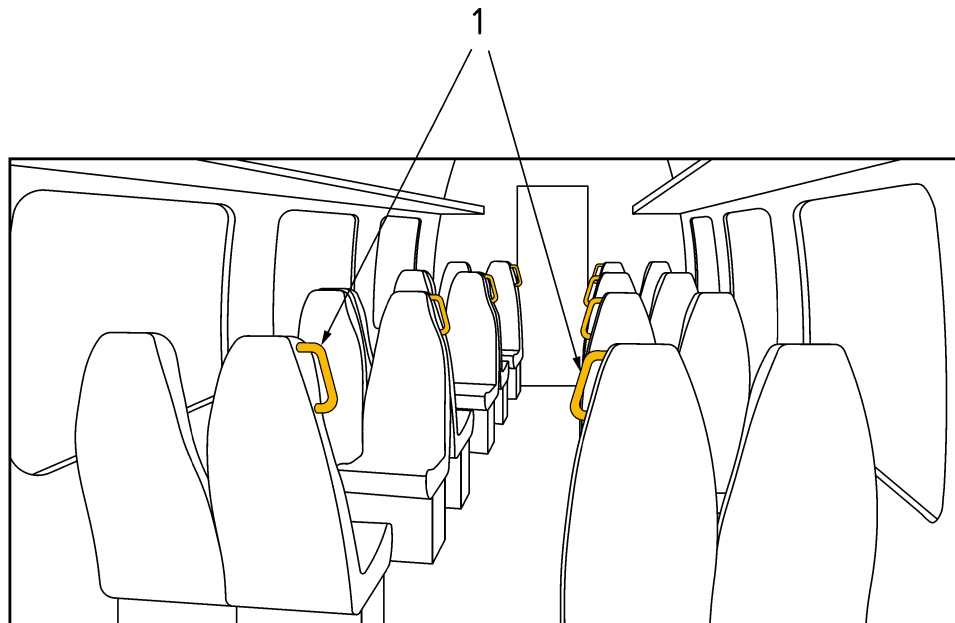
- contrast of the visual marking shall be assessed according to Annex A;
- the tactile walking surface indicators shall be assessed according to EN 16584-2.

## 5.3 Rolling stock

### 5.3.1 Seats

Handholds or other items that can be used for personal stability shall contrast with the seat:

- contrast shall be assessed according to Annex A;
- the surface of the seat that the handhold shall contrast against is the surface that can be viewed in the normal use of that handhold i.e. the front and/or back of the seat depending on the application see Figure 3.



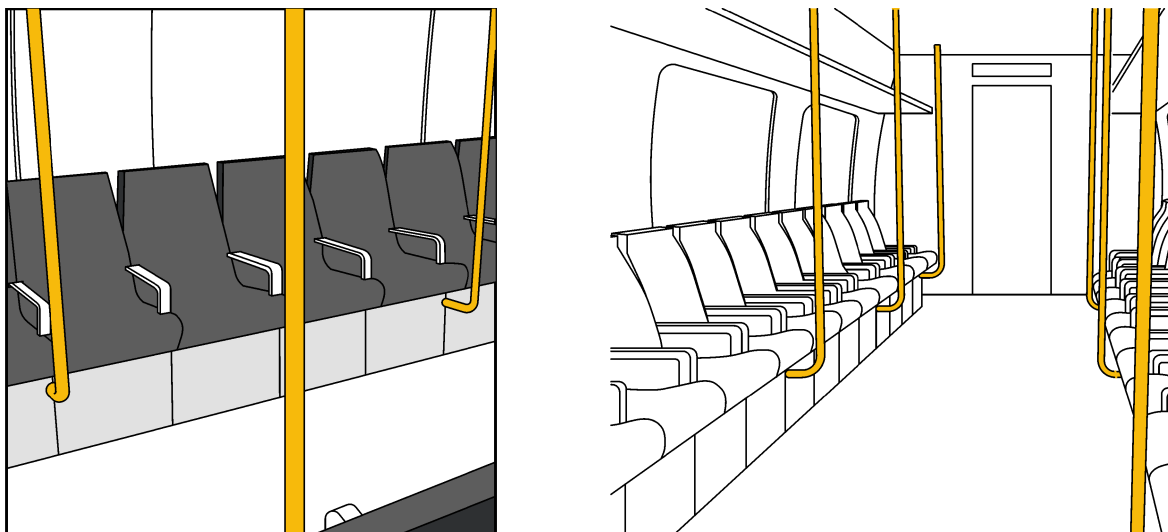
**Key**

- 1 handhold contrasting to back and front of seats

**Figure 3 — Contrast of handholds to background**

In seating areas with fixed longitudinal seats, handrails shall contrast with the vehicle interior surroundings:

- contrast shall be assessed according to Annex A;
- the vehicle interior surroundings are the surfaces behind or adjacent to the seat as viewed in the direction of normal use, these surfaces shall include the wall panels and the seat covering but not the windows or armrests see Figure 4.



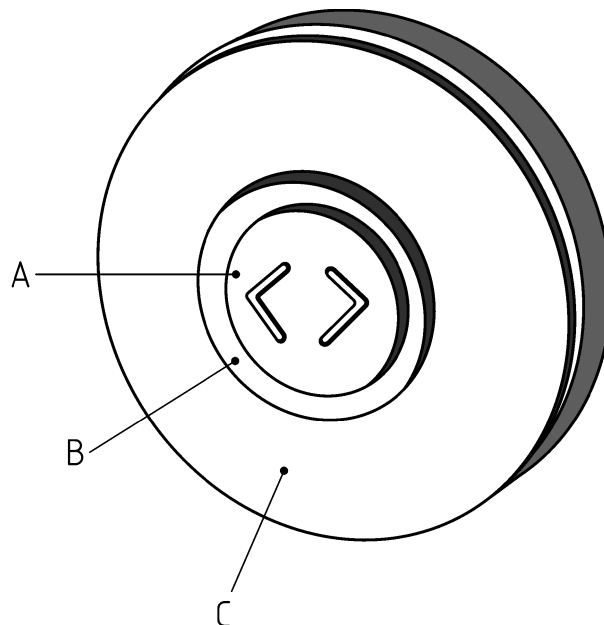
**Figure 4 — Contrast of handrails to background**

## 5.3.2 Doors

### 5.3.2.1 General

Door controls, whether manual, pushbuttons or other devices, shall contrast with the surface on which they are mounted:

- contrast shall be assessed according to Annex A;
- where the control is a manual device see Figure 1 for examples;
- where the control is a pushbutton for the vehicle exterior door (internal and external control) it shall be assessed as the pressel, the illuminating halo and the bezel combined. These elements shall have a minimum area of 5 000 mm<sup>2</sup> of which 3 250 mm<sup>2</sup> as a minimum shall contrast with the surrounding surface. See Figure 5. In all cases (C) shall be part of the contrasting area;

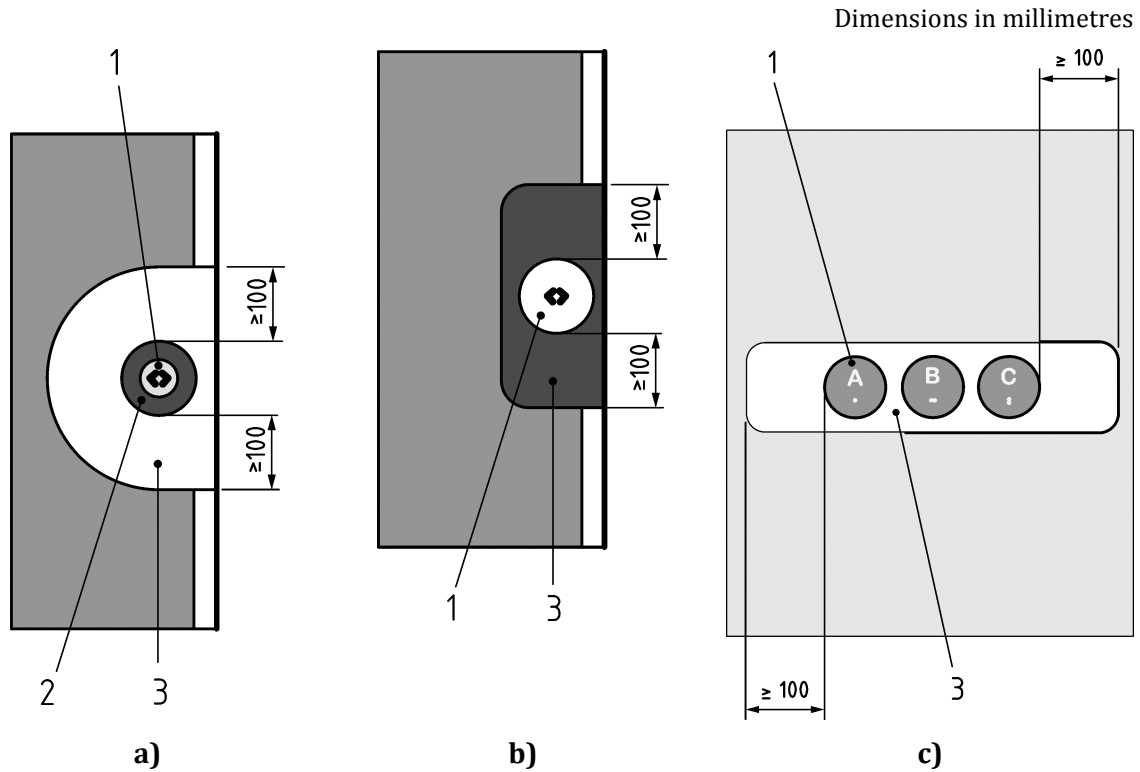


#### Key

- A pressel
- B illuminated halo
- C bezel

**Figure 5 — Key elements of an example door control pushbutton**

- the contrasting surface shall be defined as 100 mm in at least two directions (at least 90° apart) from the edge of the control bezel outwards over at least the full width of that control (the resultant area shall be at least 20 000 mm<sup>2</sup>), see Figure 6a, 6b and 6c. and Figure 1a and 1b.



**Key**

- 1 pressel
- 2 bezel, total area of pressel and bezel min. 5 000 mm<sup>2</sup>
- 3 contrasting surface, min. 20 000 mm<sup>2</sup>, min. 100 mm in at least two directions from control

NOTE The text on the control is an example only.

**Figure 6 — Examples of contrasting door controls**

**5.3.3 Exterior doors**

- 1) All exterior passenger doorways shall be marked on the outside in a way that gives a contrast to the vehicle body-side surrounding them:
  - contrast shall be assessed according to Annex A;
  - the contrasting surface shall be as defined in Annex B.

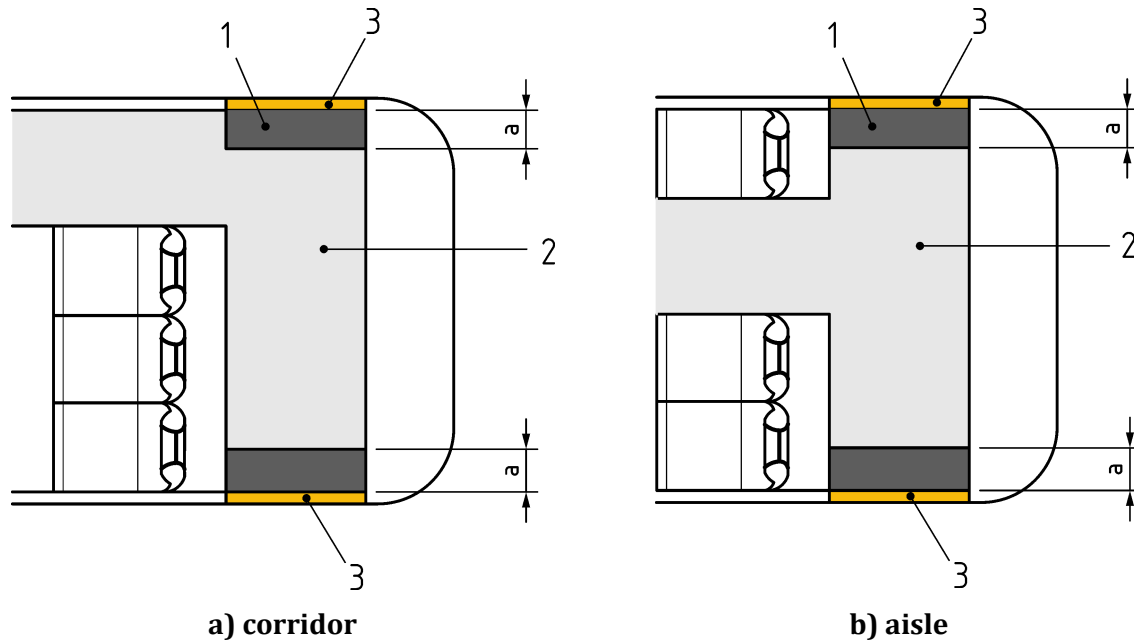
NOTE 1 Examples of compliant and non-compliant marking of the doors are shown in Annex B.

- 2) From the inside of the vehicle the position of external doorways shall clearly be marked by use of contrast on the flooring adjacent to the doorway, as compared with the rest of the flooring of the vehicle:
  - contrast shall be assessed according to Annex A;
  - the flooring adjacent to each doorway shall as a minimum be assessed as the clearway width of the external doorways and for a minimum depth of 200 mm and shall contrast

with the adjacent floor in the passenger areas of that vehicle – as shown in Figure 7a) and 7b), but can also be the complete vestibule floor – as shown in Figure 8a) and 8b);

- if entrance steps are present then Figure 9 and Figure 10 show the minimum contrasting flooring.

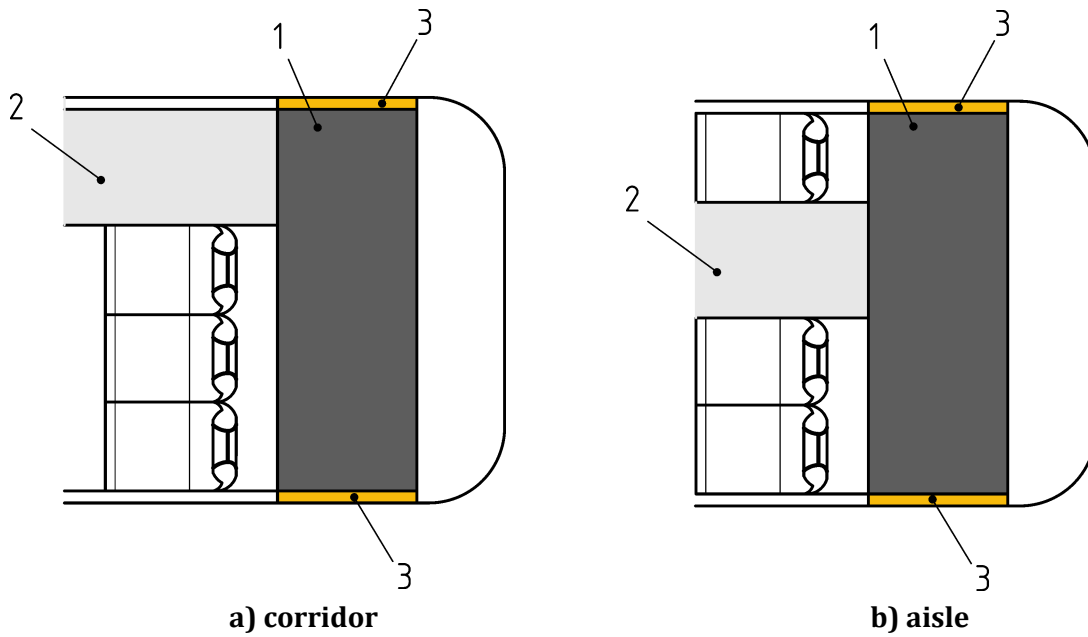
NOTE 2 The rest of the flooring in the vehicle is the primary flooring in the saloon area not the toilet etc.



**Key**

- 1 contrasting floor area
- 2 rest of the flooring of the vehicle
- 3 contrasting band
- a 200 mm minimum

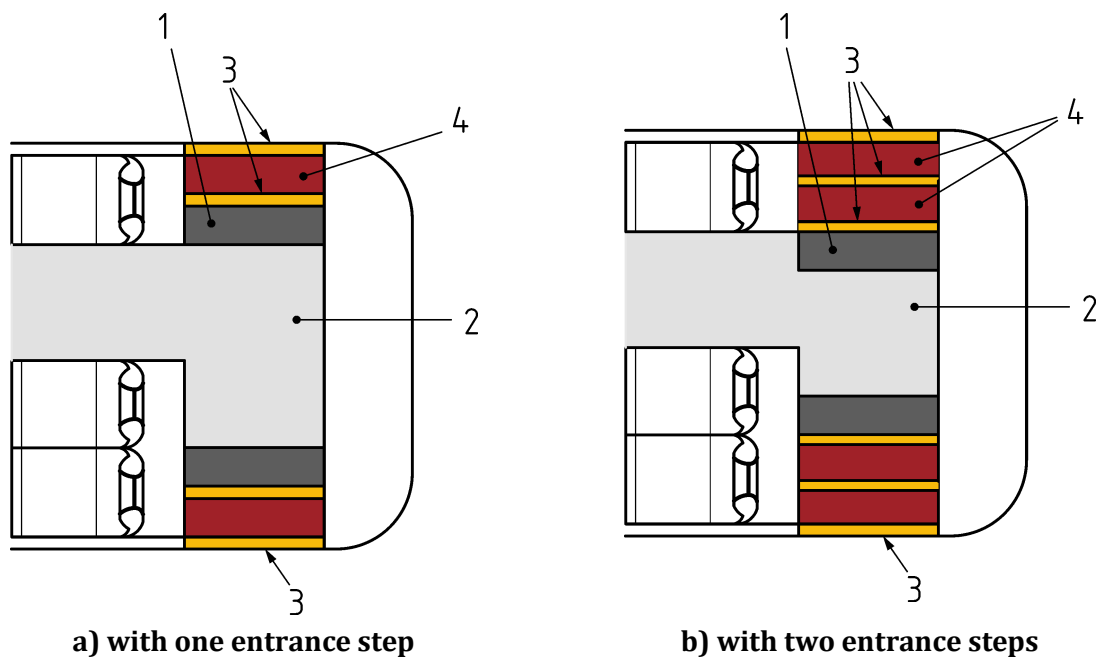
**Figure 7 — Examples of minimum doorway position markings (without entrance steps)**



**Key**

- 1 contrasting floor area (200 mm deep minimum)
- 2 rest of the flooring of the vehicle
- 3 contrasting band

**Figure 8 — Examples of alternative doorway position markings**

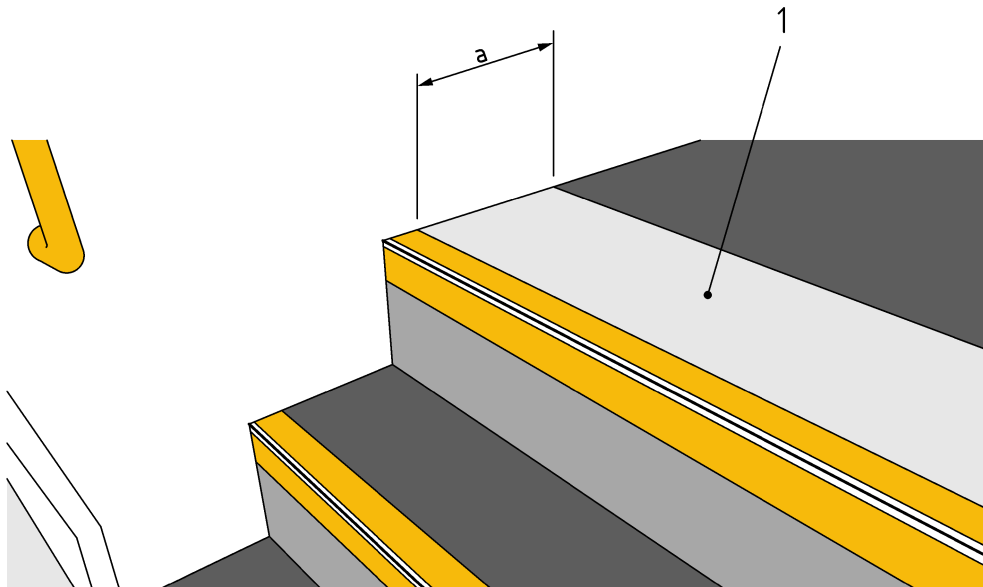


**Key**

- 1 contrasting floor area (200 mm deep minimum)
- 2 rest of the flooring of the vehicle
- 3 contrasting band
- 4 step surface covering

NOTE Contrasting band is only mandatory for the first and last step.

**Figure 9 — Examples of minimum doorway position markings (with entrance steps)**



**Key**

- 1 contrasting floor area
- a 200 mm minimum

**Figure 10— Example of minimum doorway position marking (with entrance steps)**

**5.3.4 Interior doors**

If more than 75 % of a door's visible surface is made of a transparent material, it shall be clearly marked with visual indicators that:

- i. consist of a minimum of two prominent bands made of signs, logos, emblems or decorative features (examples of compliant and non-compliant marking of the doors are shown in Annex B);
- ii. shall be at a height between 1 500 mm and 1 650 mm for the upper band, and between 850 mm and 1 000 mm for the lower band:
  - measured vertically from the walking floor;
- iii. shall contrast with the background over the entire width of the door:
  - contrast shall be assessed according to Annex A and shall be achieved on both sides of the door;

**NOTE** The background is the area behind the door as viewed in the direction of passenger movement.

- the visual bands shall either contrast as defined in Annex A to the background or the bands shall consist of two separate colours that have a minimum difference in LRV of 60 points. See Figure B.10 and Figure B.11 in Annex B. A 60 point difference in LRV achieves contrast against varying lighting conditions and backgrounds; across the full width of the transparent area the share of each of both contrasting colours shall be at least 30 % of the total surface of the band. The total share of these two colours shall be at least 75 % of the total surface of the band. The grid dimension of contrasting colours shall be more than 30 mm. See Figure B.15 in Annex B.

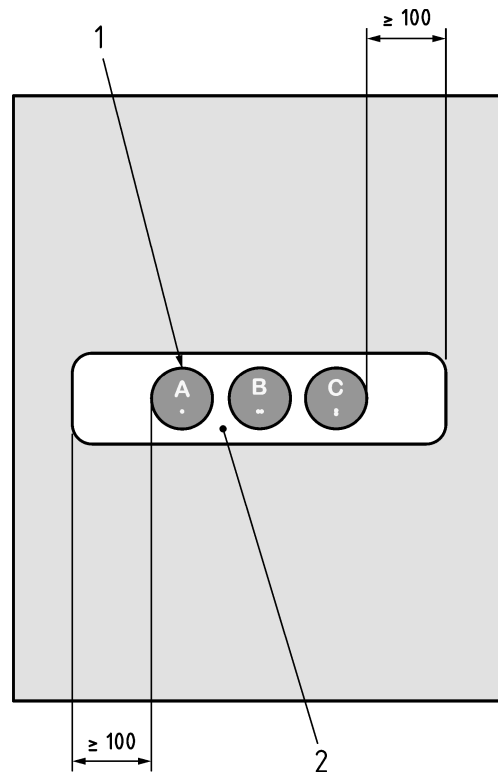
- iv. if the band is formed of signs, logos, emblems or decorative features then the remaining transparent part of the band shall form no more than 25 % of the band:
  - these bands shall be a minimum of 100 mm high;
  - measured vertically from the walking floor.

### 5.3.5 Toilets (standard and universal)

- 1) Any control device, including flushing system shall contrast with the background surface:
  - contrast shall be assessed according to Annex A;
  - the controls to be assessed under this requirement are:
    - door controls (open, close and lock);
    - toilet flush control;
    - controls for soap dispenser, hand dryer and water dispenser:
      - i. these controls, if pushbuttons shall include the pressel, the illuminating halo (if fitted) and the bezel. More than one pressel may be fitted to a bezel e.g. open and close pressels on a bezel. See Figure 11;
      - ii. the contrasting surface shall be defined as 100 mm in at least two directions (at least 90° apart) from the edge of the control outwards over the full width of that control (the resultant area shall be at least 20 000 mm<sup>2</sup>), see Figure 11:



Dimensions in millimetres



**Key**

- 1 control area min. 5 000 mm<sup>2</sup> of which 3 250 mm<sup>2</sup> as a minimum shall contrast with the surrounding surface
- 2 contrasting surface or bezel, min. 20 000 mm<sup>2</sup>, min. 100 mm in at least two directions from control

NOTE The text on the control is an example only.

**Figure 11 — Example of contrast of toilet door / flush controls**

- 2) The toilet seat and lid, and any handrails shall contrast with the background:
  - contrast shall be assessed according to Annex A;
  - the background shall be the surfaces adjacent to the toilet seat/lid, seen in every direction of normal approach. These surfaces include the floor, the wall panels and the sanitary ware (due to the space constraints in a standard toilet, the normal approach shall see the toilet seat/lid against the floor rather than the wall);
  - the background shall be the surfaces adjacent to the handrails, seen in every direction of normal approach.

NOTE In addition to the above requirements, it is good practice to ensure contrast for other elements in the toilet used by a PRM, for example wash basin, taps, toilet paper or hand towel dispenser, litter bin, coat hook etc to help with identification and usability.

### 5.3.6 Customer Information

#### 5.3.6.1 General

The requirements in 5.3.6.2 below shall apply to the following information:

- safety information and safety instructions;
- warning, prohibition and mandatory actions signs;
- information concerning the route of the train, including information about delays and unplanned stops;
- information concerning the location of on-board facilities.

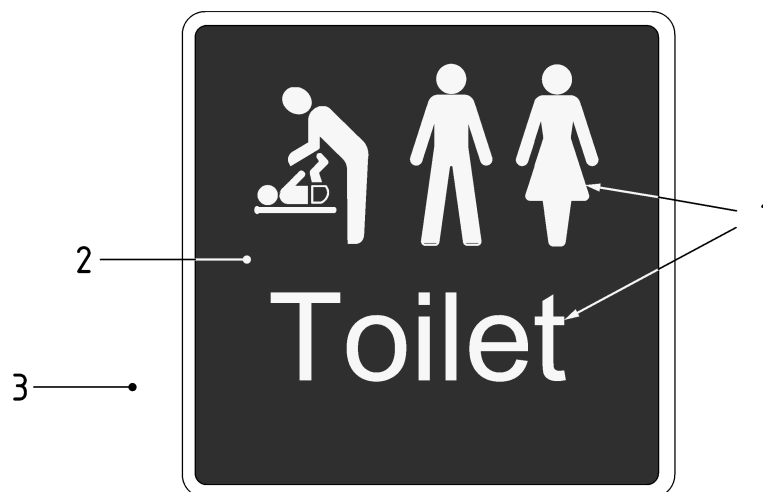
All information should be coherent and consistent with the general routeing and information system especially colour and contrast on trains.

#### 5.3.6.2 Contrast of signage, pictograms and seat identification characters

1) Visual information shall contrast with its background:

- contrast shall be assessed according to Annex A;
- the background in this context means both:
  - within the sign (see Figure 12) the background is the main colour on which the pictogram or information is displayed;
  - the main colour of the sign shall contrast with the surface on which the sign is displayed or mounted;

2)



#### Key

- 1 information on the sign
- 2 background colour of the sign
- 3 background surface on which the sign is mounted or displayed

**Figure 12 — Example sign to show background contrast required**

### 5.3.7 Height changes

Where internal steps (other than those for external access) are provided, as a minimum the first and the last step shall be indicated by a contrasting band with a depth of 45 mm to 55 mm:

- contrast shall be assessed according to Annex A;
- the band shall extend to the full useable width of the steps on both the front and the top surfaces of the step nosing;
- the depth of the top band shall be measured horizontally and perpendicular to the step edge;
- the depth of the front band shall be measured vertically down the face of the step riser and perpendicular to the step edge;
- the edge of the contrasting band closest to the step nosing shall be within 10 mm of the effective nose (vertically and horizontally see Figure 13);
- where the nose of the step is curved or chamfered, the effective nose of the step shall be as shown in prEN 16586-1:2013.

NOTE First and last step are permitted to be interpreted for this set of requirements as the top of the first and last riser as you ascend the steps.

### 5.3.8 Handrails

All handrails shall contrast with their background:

- contrast shall be assessed according to Annex A;
- the background shall be the surfaces adjacent to the handrails seen in every direction of normal approach;
- as an alternative the contrast to the background is not required when the characteristics specified in 6.2.3.2 are met.

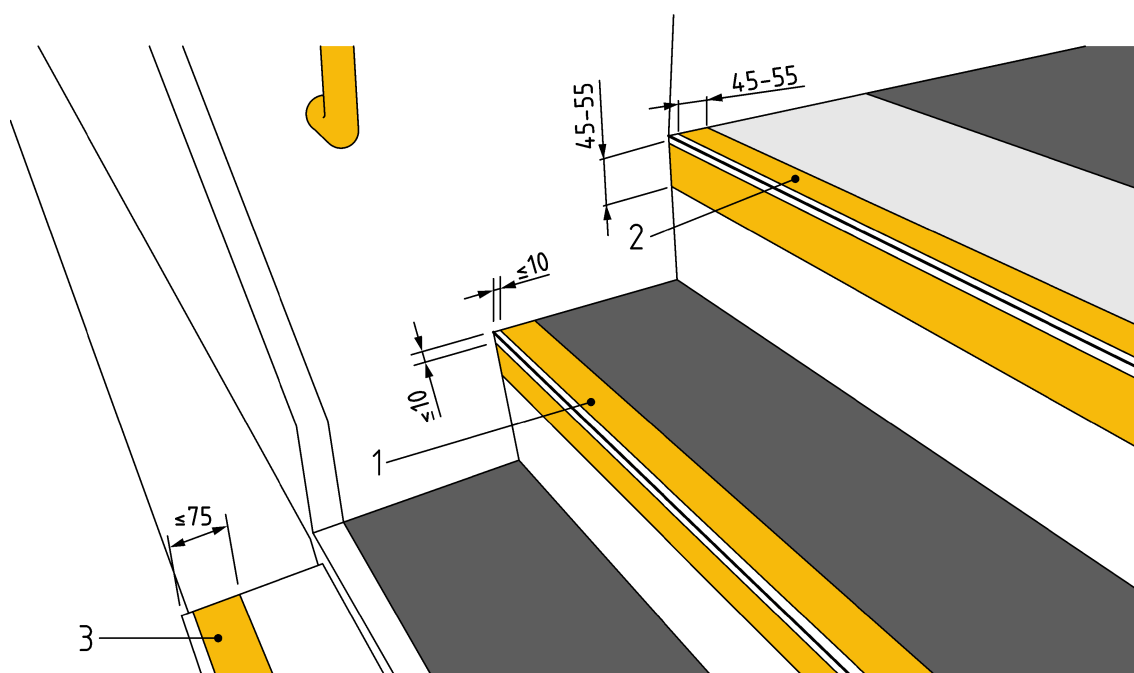
### 5.3.9 Access/egress steps

The first and the last step shall be as defined in prEN 16586-1:2013, as a minimum the first and the last step shall be indicated by contrasting bands:

- the contrasting bands shall have a depth of 45 mm to 55 mm;
  - contrast shall be assessed according to Annex A;
  - if intermediate steps are indicated by a contrasting band then all the bands shall be the same colour, depth and width;
- the band shall extend to a minimum of 80 % of the full useable width of the top surface of the first and last steps and on the front surface of the step nosing of the last step when entering;
  - the depth of the top band shall be measured horizontally and perpendicular to the step edge;

- the front band shall be measured down the face of the step riser and perpendicular to the step edge;
- the edge of the contrasting band closest to the step nosing shall be within 10 mm of the effective nose (vertically and horizontally see Figure 13); for renewal or upgrade this requirement is permitted to be within 15 mm of the effective nose;
- where the nose of the step is curved or chamfered, the effective nose of the step shall be as defined in prEN 16586-1:2013 Annex B;
- if the first step is an external step board or a moving step then this band shall be within the first 75 mm of the step edge in the horizontal plane ONLY and measured perpendicular to the step edge.

Dimensions in millimetres



**Key**

- 1 first step contrasting band
- 2 last step contrasting band
- 3 first step contrasting band when external step board or a moving step is defined as first step

**Figure 13 — Example of a first and last step indication including a movable step**

**5.3.10 Call for aid devices**

- The call for aid devices fitted in the wheelchair space, universal toilet and wheelchair accessible sleeping accommodation shall:
  - i. be distinct from all other control devices within the locations specified above;
    - assessment shall be according to EN 16584-2;

- ii. be coloured differently from other control devices;
  - assessment shall be according to EN 16584-2;
- iii. contrast with their background;
  - contrast shall be assessed according to Annex A.

#### **5.4 Boarding aids (ramps, lifts and bridging plates) for infrastructure and rolling stock**

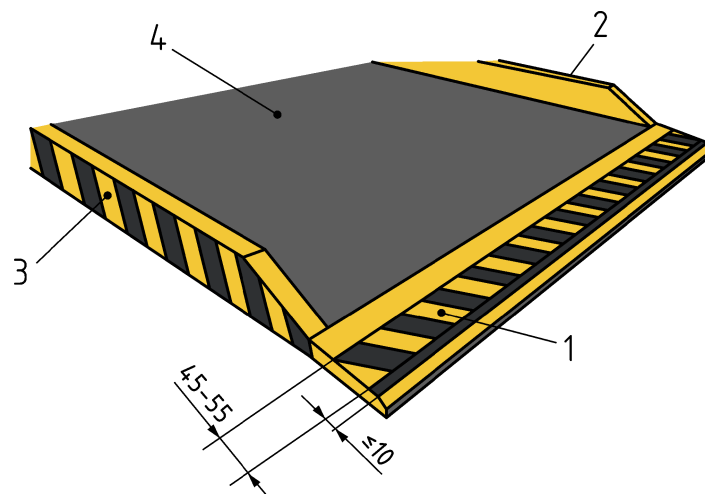
The up-stands on boarding aids (lifts or ramps) including those fitted or stored on platforms or on board rolling stock shall have:

- contrasting hazard warning bands that shall have a depth of 45 mm to 55 mm, see Figure 14;
- contrast shall be assessed according to Annex A;
- due to the variety of backgrounds against which this band will be viewed, it shall be self-contrasting according to A.3;
- the band shall be consistent over the full effective clear width of the device and start no further than 10 mm from the edge of the device.

Both the inner and outer faces of the raised sides or edges on boarding aids (lifts or ramps) including those fitted or stored on platforms or on board rolling stock shall have contrasting markings.

- for the inner faces of the raised sides or edges, contrast shall be assessed according to Annex A where the background to contrast against is the main surface of the ramp;
- for the outer faces of the raised sides or edges, contrast shall be assessed according to Annex A where self-contrasting markings shall be used;

Dimensions in millimetres



**Key**

- 1 45 mm to 55 mm wide self-contrasting hazard warning band on the bevelled up-stand
- 2 inner face of raised edge (to contrast with main surface)
- 3 outer face of raised edge (to self-contrast)
- 4 main surface

NOTE Max 10 mm allowed from edge of bevelled up-stand to self-contrasting hazard warning band

**Figure 14 — Example of use of contrast on boarding aid**

## 6 Methodologies for assessing contrast

### 6.1 General

When applying colour to two adjacent surfaces, to provide sufficient contrast, the contrast between the colours shall be determined by the light reflectance value, the hue and by the chromatic value of each.

NOTE For the purposes of this standard “Contrast” is to be assessed by the diffused light reflectance value, but can be enhanced by variation in hue and chroma.

### 6.2 Establishing LRVs

#### 6.2.1 General

Colours for all items, surfaces, materials, etc. shall be defined with a LRV, where contrast is required. The methods for defining the LRV are set out below.

#### 6.2.2 Method of establishing LRV

##### 6.2.2.1 Where the specification of the colour IS known

If the colours of the materials:

- 1) are from a colour system that defines the LRV of those colours (e.g. NCS) ; and/or
- 2) have a previously confirmed LRV (test output to be used as evidence)

then these may be used rather than re-testing when calculating the contrast.

For infrastructure only: The reflectance or the light reflectance value of the existing surface can be approximated by reference to appropriate colour swatches or panels of colour samples. This approximate method can be used for (preliminary) site assessments. Consideration should be given to tolerances with an approximation and an additional 5 points should be allowed.

#### **6.2.2.2 Where the specification of the colour IS NOT known**

This clause is based on BS 8493:2008+A1:2010.

The method of test is applicable to:

- 1) opaque paint coatings and paint systems, including those that cause extreme angular dependences of reflected light and those that have a smooth surface where the texture varies by less than 2 mm;
- 2) opaque coverings including those that cause extreme angular dependences of reflected light, and those that have a surface where the texture varies by less than 2 mm;
- 3) opaque coverings with a flexible pile, e.g. carpet;
- 4) opaque materials, including those that cause extreme angular dependences of reflected light, and those that have a smooth surface where the texture varies by less than 2 mm, e.g. finished metals;
- 5) opaque materials coated with non-opaque coatings or coverings, e.g. timber door coated with a wood stain, including those that:
  - cause extreme angular dependences of reflected light;
  - have a surface where the texture varies by less than 2 mm;
- 6) multi-coloured surfaces;
- 7) ordinary materials.

The test method is neither suitable for:

- thermochromic; photochromic; retro reflecting; fluorescent or phosphorescent surfaces

nor for

- surfaces involving electrical power for light emission,
- surfaces with self-luminous characteristics,
- free-standing, non-opaque materials, e.g. glass and clear plastic for curved surfaces.

##### **6.2.2.2.1 Apparatus**

A sphere-type spectrophotometer shall be used, capable of measuring LRV to a precision compatible with the reproducibility of 1 unit  $\Delta E$  CIE  $L^*a^*b^*$

NOTE 1 See CIE 15:2004 Colourimetry.

This is termed “instrument” within this standard. The instrument shall have a spectral range capable of measuring the LRV of a specimen at 16 wavelength points spaced at 20 nm

wavelength intervals from 400 nm across the visible spectrum. The instrument shall be capable of measuring a 10° visual field ( $Y_{10}$  or the 10° standard colourimetric observer).

The differences between the LRVs obtained from the 10° standard colourimetric observer and the 2° standard colourimetric observer ( $Y_2$ ) (CIE 15:2004) are generally minor. An LRV obtained from the 2° observer can be up to 1 point higher and for strong yellows up to 4 points higher.

The measured LRVs are affected by the geometric relationships between the measuring equipment geometry and the specimen, therefore a specific geometry is required. The instrument shall be designed such that a correctly positioned specimen is irradiated uniformly from all directions within the hemisphere bounded by its plane. The instrument aperture shall be delimited by the area over which the receiver senses flux rather than the area illuminated. Radiation reflected at the sampling aperture shall be evaluated uniformly at all directions within 5° of the axis of the collection beam. The axis of the reflected beam shall be 8° off the normal of the centre of the specimen plane in which the specimen is placed during measurements. The reduction in sphere efficiency due to specimen absorption shall be corrected to produce a linear output.

The  $d/8^\circ$  setting of the instrument makes it applicable for high-gloss surfaces as well as matt surfaces. A spectrophotometer designed to meet the same conditions as 6.2.2.2.3.2 but with the light path reversed is permitted. Where a single beam integrating sphere is used, the treatment of the outputs shall include a correction for the reduction in sphere efficiency caused by specimen absorption. Without such a correction the instrument shall give a nonlinear output.

NOTE 2 Standard illuminant, CIE  $D_{65}$ , (as defined in CIE 15:2004.)

NOTE 3 This is generally representative of a phase of daylight with a correlated colour temperature of approximately 6 500 K.

Measurement area shall be at least 7 mm diameter compatible with that provided by commercially available spectrophotometers.

The measurement area allows the LRV of solid colour surfaces and surfaces having a fine coloured pattern to be determined.

#### **6.2.2.2.2 Preparation of test specimens**

##### **6.2.2.2.2.1 General**

Three specimens shall be selected as being representative of the surface for the test. Where there is variability in the colour of the three specimens, then nine specimens shall be selected.

NOTE Variability in the colour of the three specimens occurs where the difference between the highest and lowest LRV is greater than or equal to 4.

##### **6.2.2.2.2.2 Specimen preparation**

The surface of the specimens shall be clean and representative of the surface of the material. There shall be no pressure marks on, or foreign matter attached to, the surface of the specimens to be tested. Plastic or painted specimens require no specimen preparation but shall be clean. Prior to starting the test, specimens that are sensitive to stroking shall be brushed with a clothing brush, once against the grain, where the specimen would appear darker, and then once with the grain, where the specimen would appear lighter and more homogeneous in structure. Cut pile carpets shall be brushed with a clothing brush in the direction of the natural pile lay before measurement.

NOTE 1 Surfaces that are not sensitive to stroking do not need to be pre-treated in this way.



Prior to starting the test, all specimens shall be held between an observer and an unobstructed patch of sky seen through a north-facing window glazed with clear glass. Any specimens that are light permeable, or non-opaque, shall not be measured.

Where there is concern with regard to the stability of the colour and appearance of a specimen over the period of the test, the specimen shall be tested in accordance with measurement requirements of the appropriate European or National Standard for the material as represented by the specimen.

NOTE 2 For textiles the stability of the colour and appearance of a specimen is defined in EN ISO 105-B05.

Specimens shall be large enough to extend beyond the measurement area of the instrument.

### **6.2.2.2.3 Procedure**

#### **6.2.2.2.3.1 Instrument performance and measurement**

The manufacturer's recommendations for monitoring the instrument performance and maintenance shall be followed.

#### **6.2.2.2.3.2 Calibration**

The instrument shall be switched on and have been allowed sufficient time for stabilization in accordance with the manufacturer's recommendations. Where applicable, it shall be ensured that the instrument has sufficient battery voltage and capacity to undertake the required measurements.

Select the measurement conditions required for calibration of the instrument being used as follows:

- 1) wavelength range and interval;
- 2) size of aperture;
- 3) specular component included;
- 4) standard illuminant type;
- 5) where there is choice of percentage UV, select 100 % UV.

NOTE The sequence to be followed varies between different instruments.

The instrument shall be calibrated in accordance with the manufacturer's recommendations.

During the use of the instrument, repeat the calibration at regular intervals in accordance with the manufacturer's recommendations.

Where appropriate, re-calibration may be required at regular intervals during measurements.

#### **6.2.2.2.4 Test**

The sequence to be followed may vary from one instrument to another, but shall include the following steps:

- a) the specimen shall be determined to be opaque, using the method shown above;
- b) the method of preparation and presentation of the specimens shall be selected;

- c) if the instrument conditions required to measure the specimen are not those used during the calibration, adjust to comply with the requirements of 6.2.2.2.3.2;
- d) measure the LRV of the specimen in accordance with this standard, using CIE Tristimulus  $Y_{10}$ , Illuminant D65 (as defined in CIE 15:2004) and the  $10^\circ$  colourimetric observer;

NOTE 1 See 6.2.2.2.6 item j.

- e) all measurements shall be taken with the instrument using even pressure without deforming the specimen.

When selecting the measuring points, they should be distributed over the entire surface of the specimen.

- f) the measuring points for specimens that have a texture or surface structure shall be distributed over the surface so as to ensure that all differences in surface texture or structure are measured;
- g) the specimens shall be measured on a measurement grid as shown in Figure 15a) and Figure 15b).
- h) for specimens which do not have a patterned or textured surface a specimen size of a minimum  $150\text{ mm} \times 100\text{ mm}$  shall be used. LRV measurements shall be taken at the centre points of a  $76\text{ mm} \times 76\text{ mm}$  grid that covers the surface of the specimen, as shown in Figure 15b).
- i) for multi-coloured specimens where areas of the surface are composed of different uniform colours, which when viewed from a distance of 3 m remain distinct areas of colour, the LRV shall be measured as follows. At least four measurement points shall be located on each distinct area of colour. Following the first measurement at each measurement point, the instrument shall be turned  $90^\circ$  three times and measurements taken after each  $90^\circ$  turn. The results of each measurement shall be recorded and the average LRV for each area of distinct colour determined.

The average LRV ( $LRV_{av}$ ) for the overall specimen is given by:

$$LRV_{av} = [(LRV_{av1} \times A_1) + (LRV_{av2} \times A_2) + (LRV_{avn} \times A_n)]/A$$

Where:

$LRV_{av}$  = average LRV of the overall specimen (CIE  $Y_{10}$ )

$LRV_{av1}$  = average LRV of distinct colour "1" of the specimen (CIE  $Y_{10}$ )

$A_1$  = area of distinct colour "1" ( $\text{m}^2$ )

$LRV_{av2}$  = average LRV of distinct colour "2" of the specimen (CIE  $Y_{10}$ )

$A_2$  = area of distinct colour "2" ( $\text{m}^2$ )

$LRV_{avn}$  = average LRV of the last distinct colour "n" on the specimen (CIE  $Y_{10}$ )

$A_n$  = area of the last distinct colour "n" ( $\text{m}^2$ )

$A$  = total area of specimen ( $\text{m}^2$ ).

NOTE 2 All of the “Y” terms in the formula in 6.2.2.2.4, item i) are  $Y_{10}$ , as 6.2.2.2.4, item d).

NOTE 3 The area of the specimen is to be either 0,202 5 m<sup>2</sup> for a 450 mm × 450 mm specimen or 0,81 m<sup>2</sup> for a 900 mm × 900 mm specimen.

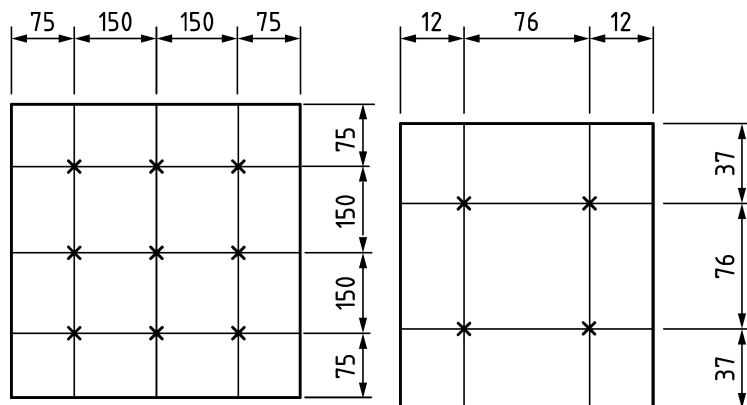
Where the surface comprises many small colour specks or chips which, when viewed from a distance of 3 m, assume the appearance of one slightly varying colour, the average LRV ( $LRV_{av}$ ) is found in accordance with 6.2.2.2.4.

Measurements on general surfaces, including carpet specimens, shall be taken on specimens of a minimum size of 450 mm × 450 mm where the nature of the pattern is such that a specimen size of these dimensions is fully representative of the pattern. LRV measurements shall be taken at the 9 centre points of each of the 150 mm × 150 mm area grids which cover the surface of the specimen, by placing the measurement point at the centre of equal areas of the specimen surface, as shown in Figure 15a).

Following the first measurement at each measurement point the instrument shall be turned 90° three times and measurements taken after each 90° turn. The results of each measurement shall be recorded and the average LRV ( $LRV_{av}$ ) for the specimen determined.

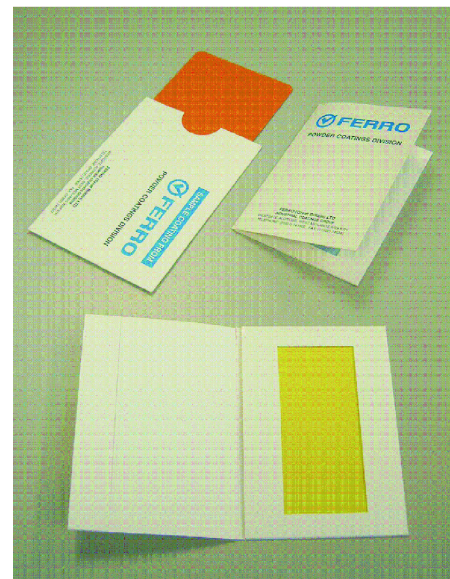
Where patterns on surfaces cannot be fully represented by a specimen of this size (450 mm × 450 mm) then a specimen size of 900 mm × 900 mm shall be used and the LRV measurements shall be taken at the 36 centre points of each of the 150 mm × 150 mm grid, set out to place the measurement point at the centre of equal areas of the specimen surface.

Dimensions in millimetres



a) measurement grid for 450 mm × 450 mm specimens

b) measurement grid for 100 mm × 150 mm specimens



c) typical paint samples (100 mm × 150 mm)

Figure 15 — Measurement grids and paint samples

#### 6.2.2.2.5 Expression of results

The instrument shall, either independently or with additional software and hardware, calculate the LRV, which is the CIE Tristimulus Y<sub>10</sub> value.

Additionally the x<sub>10</sub>, y<sub>10</sub> of the colour shall be calculated. Output and record the LRV as required.

#### 6.2.2.2.6 Test report

The results of all the LRV measurements for the specimen surface shall be reported in a way that enables the LRV difference between two visually adjacent surfaces to be readily determined. The test report shall contain at least the following information:

- a) the number and date of this standard, for example EN 16584-1:2017;
- b) name of organization carrying out the test;
- c) date of test;
- d) the specimen identification details;
- e) the number of specimens measured;
- f) the method of specimen preparation used;
- g) identification of the instrument used including, where appropriate, manufacturer, model, serial number and optical geometry;
- h) details of the conditions of test as specified in 6.2.2.2.4;
- i) measurement area and observer angle;
- j) description of specimen including CIE Y<sub>10</sub>, x<sub>10</sub>, y<sub>10</sub> colour identification;
- k) description of additional feature, e.g. texture, gloss or grain;

NOTE In the test report inclusion of a visual record of the specimen, e.g. a photograph or scan is useful.

- l) size of specimen used in the test;
- m) LRV measurements for all measurement points;
- n) average LRV (LRV<sub>av</sub>) measurement for each specimen and the range of measured LRVs;
- o) for multi-coloured specimens the average LRV for the overall specimen (LRV<sub>av</sub>) and the average LRV for each of the distinct colours on the specimen;
- p) any deviations from the specified procedures.

### 6.2.3 Specific assessment criteria for stainless steel

#### 6.2.3.1 General

Stainless steel has many benefits that make it a desirable material for handrail, grab rail and grab pole applications but as it is a reflective surface it has had problems with consistency when

measuring resulting in a LRV variance in excess of 5 points. The following conditions shall be considered when *assessing* stainless steel.

### 6.2.3.2 For cylindrical grab-poles, grab-rails and handrails ONLY

For cylindrical grab-poles, grab-rails and handrails (including bends in that rail or pole) the use of stainless steel with a 'dull buffed' surface finish shall be permitted as it performs as a self-contrasting pole (ONLY when the lighting is in accordance with EN 13272 for rolling stock and European or national standards for infrastructure).

A 'dull buffed' surface shall have a uniform straight grained finish that is equivalent to either a 2J mechanically brushed or dull polished finish according to EN 10088-2:2014.

### 6.2.3.3 Other applications of stainless steel

Other than the specific situation in 6.2.3.2, stainless steel in all other applications shall meet the contrast requirement to its background in accordance with the assessment/measuring methodology as in Annex A and 6.2.3 and shall be assessed with an increased difference of 35 points (0,35) to ensure that the variance in readings does not drop below 30 points.

## 6.3 Method of assessing contrast with LRVs established (as in 6.2)

### 6.3.1 General requirements for contrast

The contrast shall be assessed using Figure A.1 in Annex A which has been derived from the following:

- i. Michelson contrast formula in A.1 up to 30 points then a 30 point constant difference with an initial 10 point minimum difference for non flooring finishes;
- ii. flooring finishes use the lines derived from the Michelson contrast formula in A.1 from 0 up to the 30 point difference point on the graph (this is required due to the degradation of a flooring material with use or wear).

NOTE 1 See Annex A for further clarification and worked examples (written examples i.e.  $L_0$  of 1 requires  $L_h$  of 11 to 100.)

NOTE 2 Michelson contrast formula referenced as  $K = \frac{L_o - L_h}{L_o + L_h}$

### 6.3.2 Specific requirements for contrast on signage

Establish LRV for parts of the sign.

— If the LRVs for the parts of the sign are not known the method is according to 6.2.2.2.

Once the LRVs for the parts of the sign are established, use the simple calculation based on 60 point difference according to A.2.

See Figure A.2 for simple calculation method.

### 6.3.3 Durability of contrast

To maintain minimum required contrast in normal operation and not just when assessed as new, when reviewed at type test etc, the selected materials chosen to deliver requirements shall be demonstrated to have suitable properties that make them fit for purpose, e.g. decals shall be UV stable and colour fast as applicable to the relevant application. ISO 17398 shall be used when assessing the durability of signage and decals.

For example if a selected material or process is known to degrade over the design life in a way that impacts its contrasting properties, this should be anticipated and compensated for in the original colours selected. Therefore if the LRV is anticipated to degrade by 8 points, for example, then the original difference should be at least 38 points, not the 30 point minimum prescribed.

An alternative method of proving contrast is being maintained can be to test periodically for compliance to the minimum requirement.

#### **6.3.4 Specific requirements for electronic displays**

When the relevant criteria from the electronic displays is known then a calculative *K* value of 0,6 or greater is required.

See Annex C of this standard for the method of calculation and EN 16584-2:2017, Annex D for relevant information.

The criteria that are pertinent to this assessment are:

- a) visual acuity of 0,5 shall be the minimum (or prescriptive character height requirements in EN 16584-2:2017, Clause 5 with a recommended 0,1;
- b) reading distance range, height and angle range of the display, height of the eye points shall be assumed to be 1,5 m above the floor;
- c) ambient light limits (see EN 16584-3);
- d) luminance of the display and reflection on the screen (including the protective housing/cover/ glass);
- e) character heights (quantity of information and size of display are a key consideration when defining the character height).

Points a) to e) can be assessed independently to the installation (e.g. under laboratory conditions) except point c) which is dependent on the installation so can only be defined as a set of limits under which a display is acceptable.

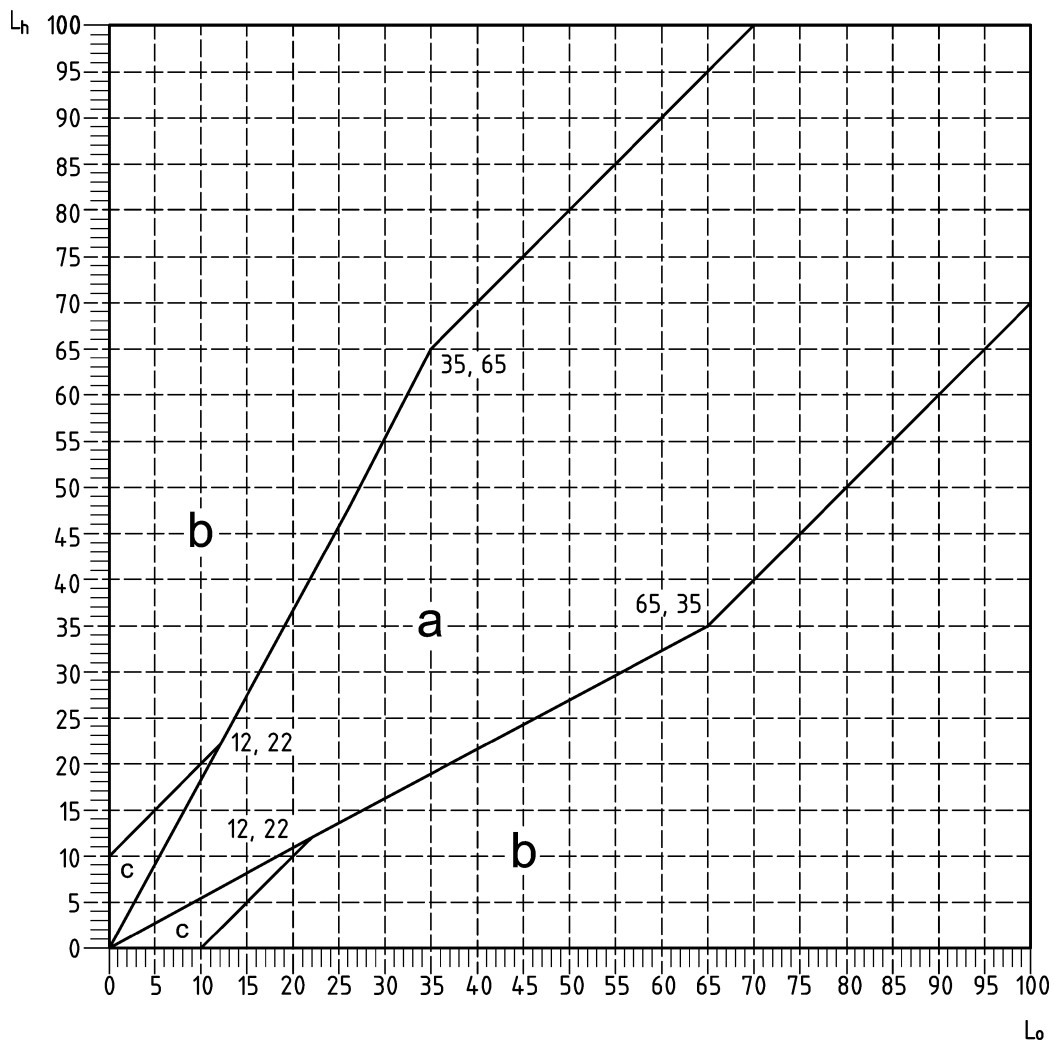
NOTE See to EN 16584-2:2017 for applicable criteria when assessing electronic display contrast.

## Annex A (normative)

### Contrast charts

#### A.1 General

When LRVs of the surfaces that are required to contrast are known, these should be plotted on the appropriate chart. For general contrast use Figure A.1.

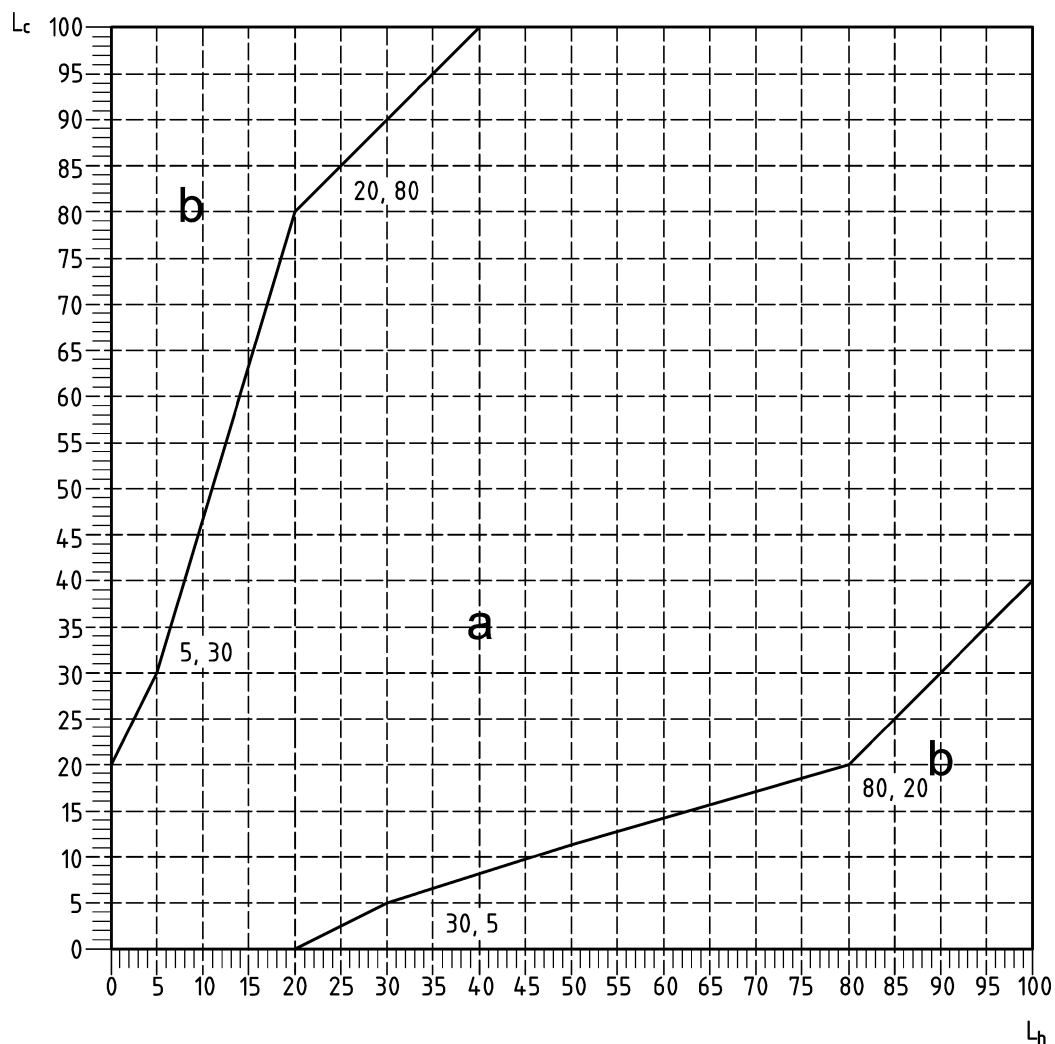


#### Key

- 'a' LRVs that intersect in this area do not achieve a compliant contrast level
  - 'b' LRVs that intersect in this area achieve a compliant contrast level
  - 'c' LRVs that intersect in this area achieve a compliant contrast level ONLY if the material being assessed is a flooring material
- $L_o$  the LRV of the object  
 $L_h$  the LRV of the background or adjacent surface

Figure A.1 — General Contrast Chart

For signage contrast use Figure A.2.



**Key**

- a' LRVs that intersect in this area do not achieve a compliant contrast level
- 'b' LRVs that intersect in this area achieve a compliant contrast level
- L<sub>h</sub> the LRV of the background or adjacent surface
- L<sub>c</sub> the LRV of the character (number, letter or symbol)

**Figure A.2 — Colour contrast for signage**

The position of the intersection point of the LRVs on the chart determines whether compliant contrast has been achieved.

**A.2 Worked examples for contrast**

Worked examples of the values vs. the compliant contrast diagram are contained below.



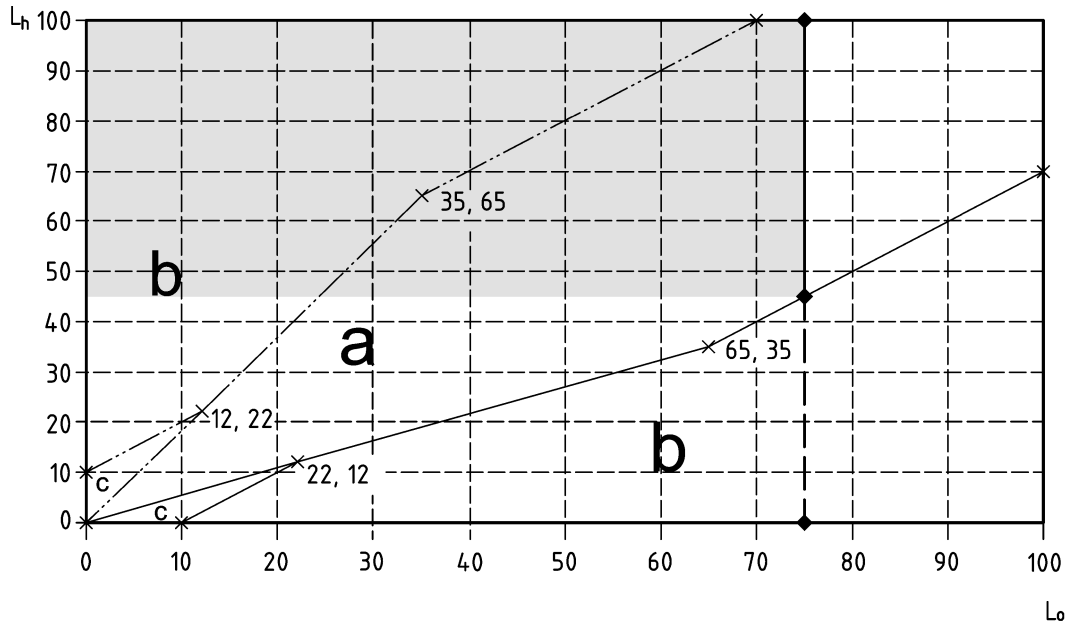


Figure A.3 — Worked example 1

Figure A.3 gives an example where the value of  $L_0$  is 76 then the value of  $L_h$  to be compliant shall be between 0 and 46 points.

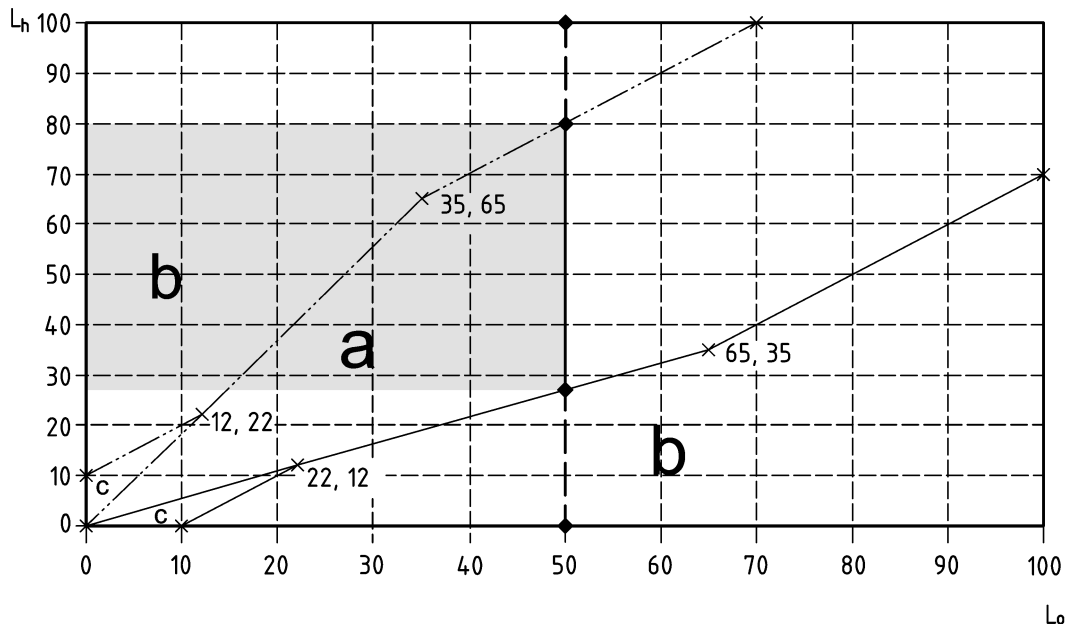


Figure A.4 — Worked example 2

Figure A.4 gives an example where the value of  $L_0$  is 50 then the value of  $L_h$  to be compliant shall be between 0 and 26 or between 80 and 100 points.

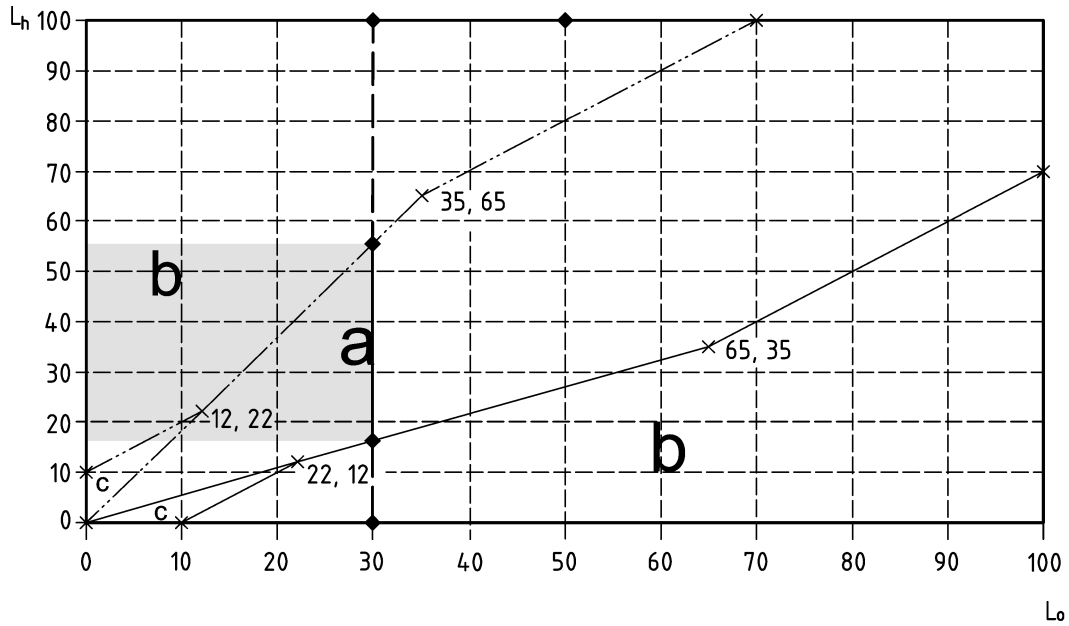


Figure A.5 — Worked example 3

Figure A.5 gives an example where the value of  $L_0$  is 30 then the value of  $L_h$  to be compliant shall be between 0 and 16 or between 56 and 100 points.

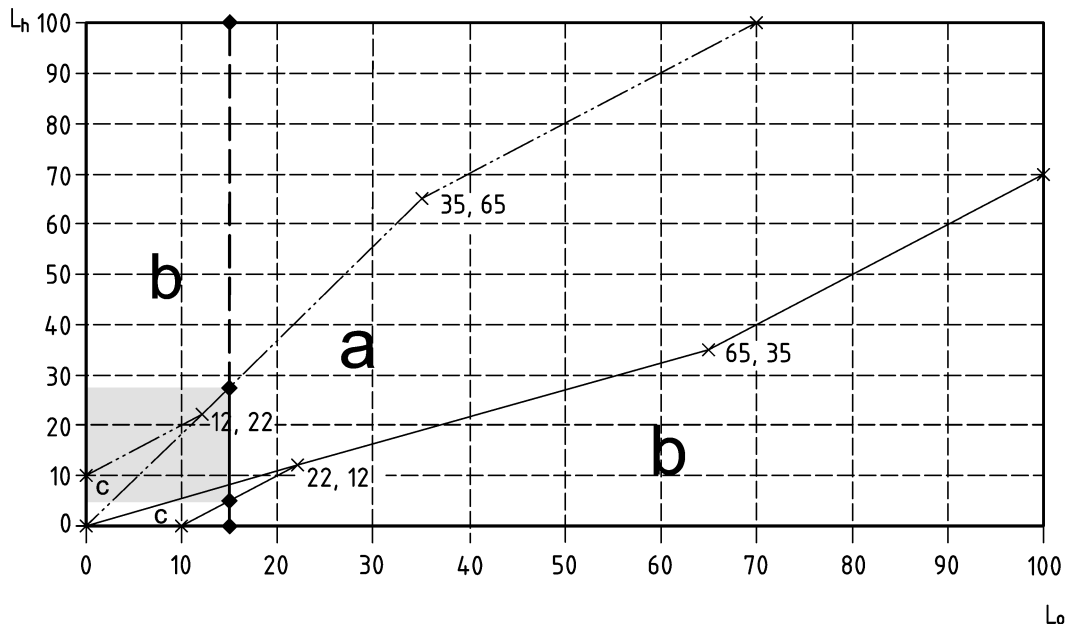


Figure A.6 — Worked example 4

Figure A.6 gives an example where the value of  $L_0$  is 14 then the value of  $L_h$  to be compliant shall be between 0 and 5 or between 26 and 100 points unless the materials being assessed are flooring materials which allows the use of zone c and therefore the lower range for  $L_h$  would be between 0 and 7.

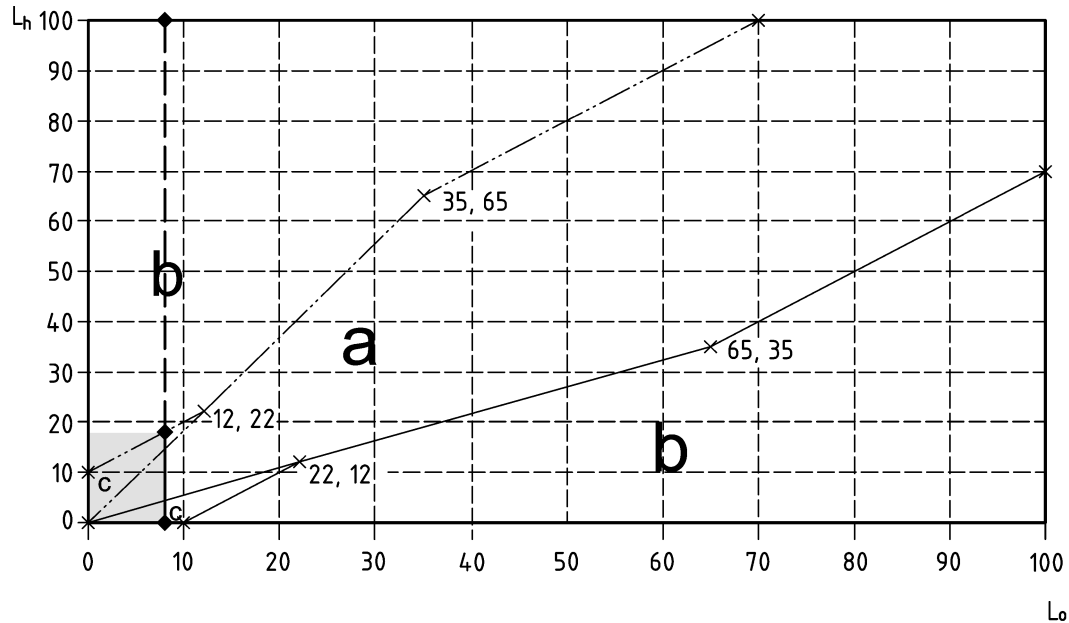


Figure A.7 — Worked example 5

Figure A.7 gives an example where the value of  $L_0$  is 7 then the value of  $L_h$  to be compliant shall be between 17 and 100 points unless the materials being assessed are flooring materials which allows the use of zone c and therefore the lower range for  $L_h$  would be between 0 and 4 and the upper range of 13 to 100.

### A.3 Self contrasting bands

Where a contrasting band is made up from two contrasting colours, with a minimum difference in LRV of 60 points, the requirement to contrast with its background need not be met. This shall be used for transparent obstacle marking and hazard warning bands on boarding aids where the specific background is difficult to determine.

- i. for transparent obstacles see 5.2.3
- ii. for interior doors see 5.3.4 and Annex B
- iii. for hazard warning bands see ISO 3864-1

## Annex B (normative)

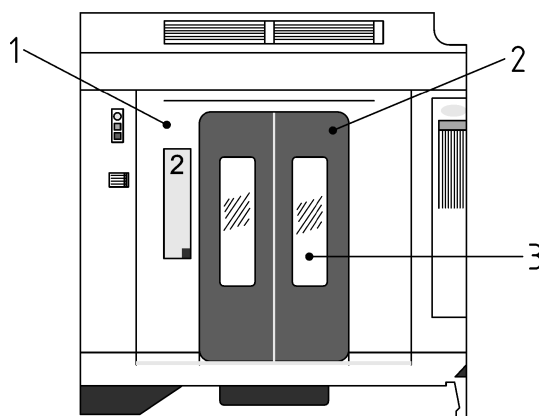
### Contrast for doors and transparent obstacles

#### B.1 General

This annex contains diagrams and examples to explain the requirements in Clause 5 of this standard, for contrast of doors and transparent obstacles.

#### B.2 Exterior doors

This clause contains diagrams and examples to explain the requirements in Clause 5 of this standard, for the contrast between the passenger body-side entrance doors and the exterior of the train.



#### Key

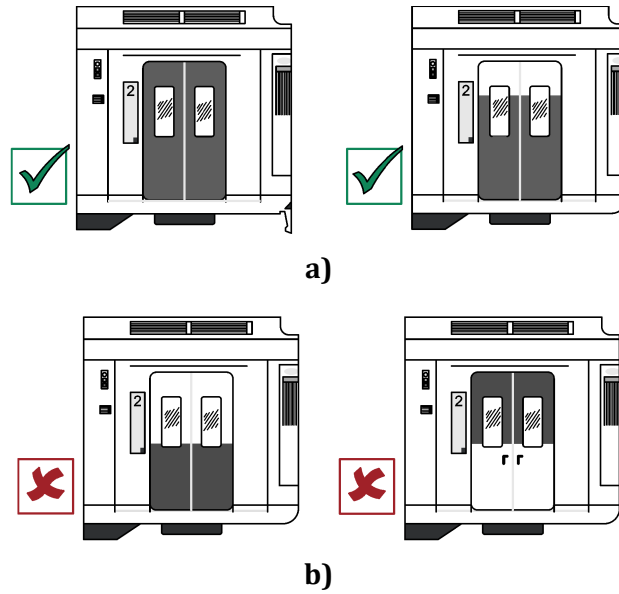
- 1 exterior of train
- 2 door leaf (visible part)
- 3 window (transparent part of the door)

If there is another element of the door leaf assembly other than seals, for example window frame, it shall be coloured as the main contrasting part of the door leaf.

**Figure B.1 — Key elements for door contrast requirements**

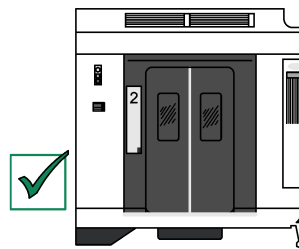
#### B.3 Case 1: If the window is less than or equal to 40 % of the visible door leaf

The contrast area shall be as a minimum 75 % of the door leaf starting not higher than a point corresponding with the first step (see Figure B.2 for examples).

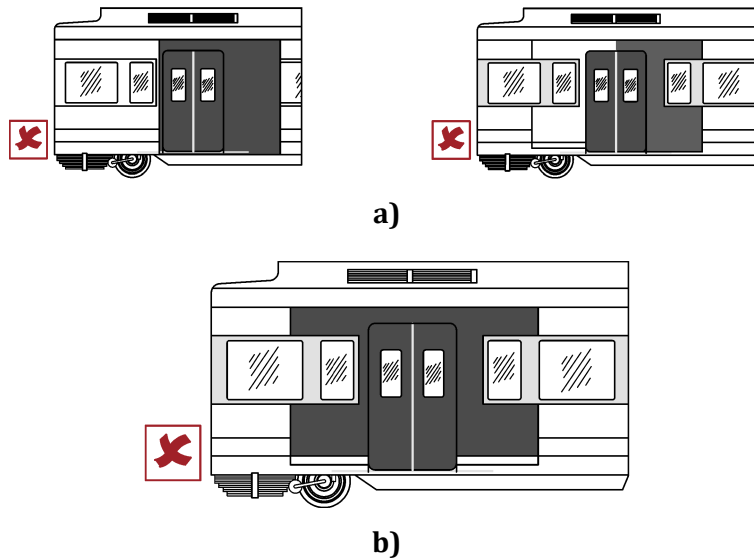


**Figure B.2 — Two compliant and two non-compliant examples**

Where the contrast area extends beyond the door leaf it should be no greater than or equal to 1,5 times the width of the visible door leaves (when closed) and centred on the axis of the door leaf or leaves (see Figure B.3 for compliant examples and Figure B.4 for non-compliant examples).



**Figure B.3 — Example showing a compliant contrast area not exceeding 1,5 times the width of the door leaves and centred on the door**



**Figure B.4 — Examples of non-compliant contrasting areas where they are either not centred and/or exceed 1,5 times the width of the door leaves**

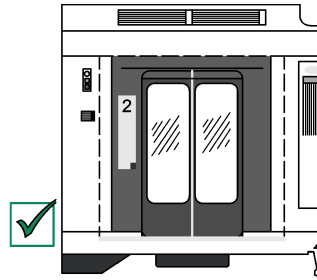
#### **B.4 Case 2: If the window is greater than 40 % of the visible door leaf**



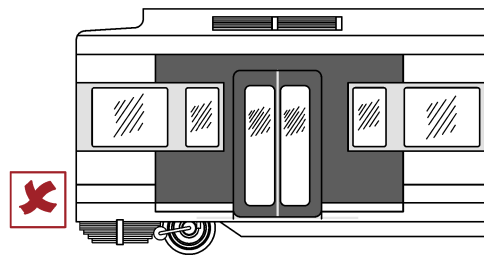
**Figure B.5 — Example of where the window is greater than 40 % of the total visible area of the door leaf**

Where the transparent area of the window in the door leaf is greater than 40 % of the total visible area of that door leaf the following shall apply:

- the contrasting area shall be a minimum of 75 % of the total area of the door leaf or leaves (where double doors are fitted);
- the contrasting area shall therefore extend to the bodyside but shall not be greater than 1,5 times the length of the doors;
- the contrasting area shall be centred on the axis of the door leaf or leaves (see Figure B.6 for a compliant example and Figure B.7 and B.8 for non-compliant examples).



**Figure B.6 — Compliant example showing the contrasting area correctly centred on the axis of the door and of the required surface area**



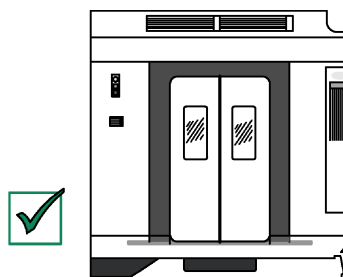
**Figure B.7 — Non-compliant example as the contrasting area is not of the required surface area**



**Figure B.8 — Non-compliant examples as the contrasting area is not centred on the axis of the door**

### **B.5 Case 3: Alternative if the door leaf is not coloured to contrast with the bodyside**

If the door leaf is not coloured to contrast with the bodyside, a contrasting area shall be created on the bodyside that shall be to the sides and on top of the door leaves. This contrasting area shall be as a minimum 150 mm wide at the sides of the doorway up to the full height of the door leaves with the addition of a minimum of 150 mm above the door leaves across the full width of the door leaf or leaves (plus the additional band width on either side). See Figure B.9 for a compliant example.



**Figure B.9 — Compliant example**

## B.6 Markings for interior doors or transparent obstacles

This clause contains diagrams and examples to explain the requirements in Clause 5 of this standard, for markings for interior doors or transparent obstacles by means of a contrasting band.

The contrasting band shall be made up from two contrasting colours unless it can be proven that a solid single colour band contrasts with the background as described in 5.3.4.

A minimum of 75 % of the area of the 100 mm tall band across the door or obstacle shall be made from two contrasting colours and a maximum of 25 % of the area of the contrasting band may be transparent or other. The minimum either of the two colours shall be 30 % of the total contrasting band area but combined shall always be a minimum of 75 % of the total contrasting band area.

The contrasting band shall always be across the full width of the transparent area of the door or obstacle.

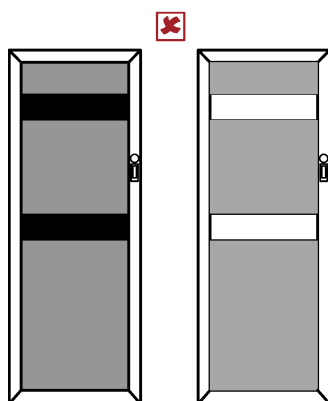


Figure B.10 — Non-compliant examples (not self contrasting)

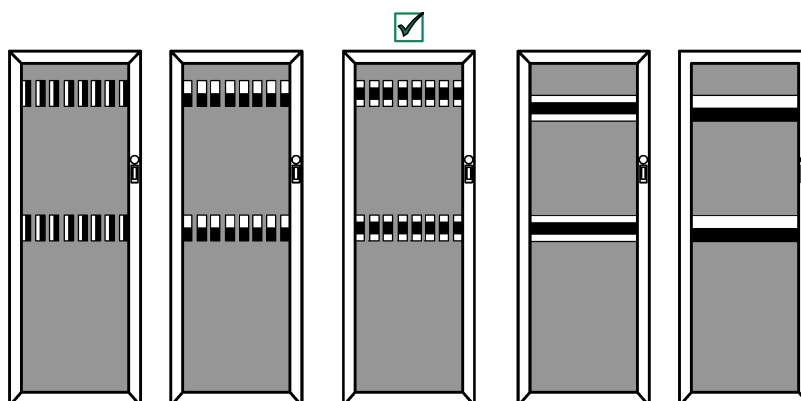


Figure B.11 — Compliant examples (self contrasting with correct proportions and areas of colour)



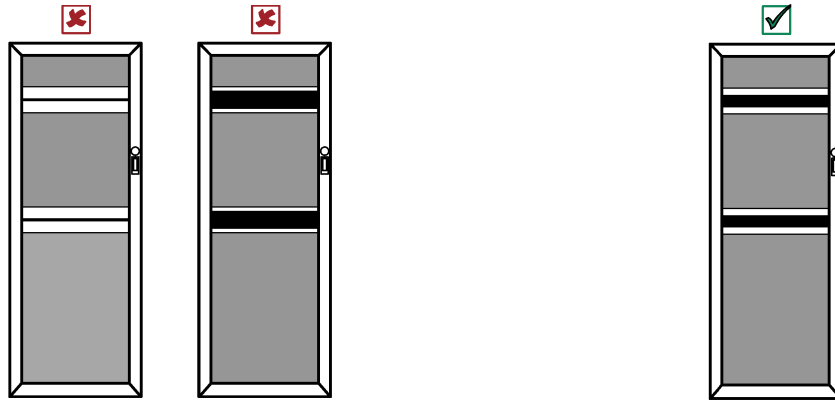


Figure B.12 — Two non-compliant examples where the proportion of each colour is wrong and a compliant example

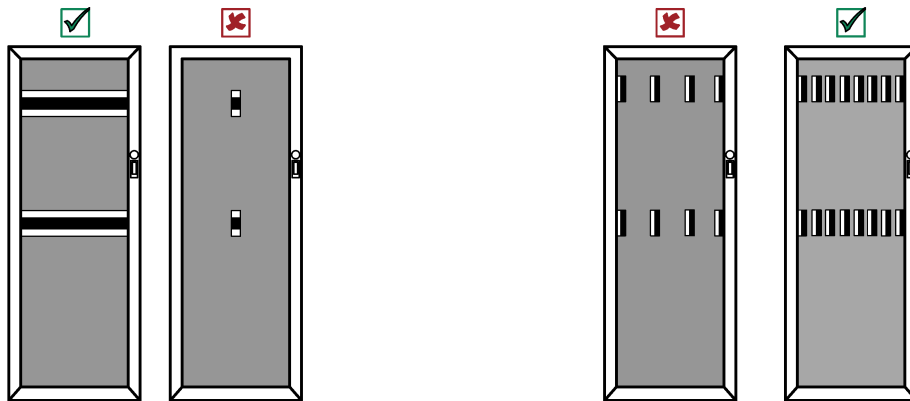


Figure B.13 — Two non-compliant examples as the total area of colours is wrong and two compliant examples

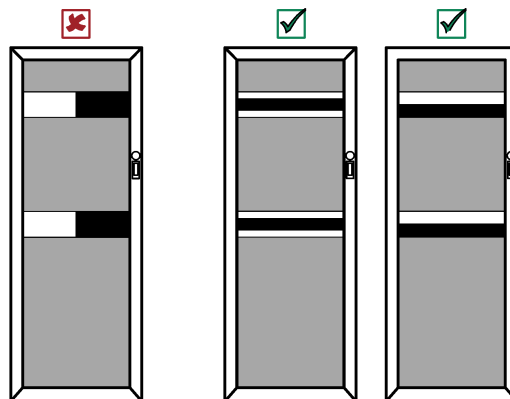
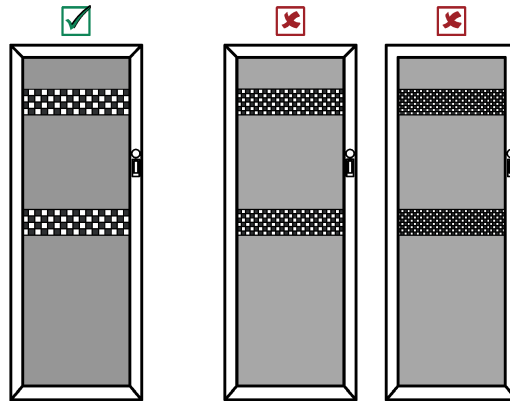


Figure B.14 — Two examples where the proportion of each colour is compliant and a non-compliant example



**Figure B.15 — Example showing a compliant band (120 mm height) made up from the minimum 30 mm x 30 mm grid and two non-compliant examples where the grid used is less than 30 mm x 30 mm**

## Annex C (normative)

### Effective contrast calculation for displays

#### C.1 Illuminated displays

For illuminated displays, the luminance densities  $L_1$  and  $L_2$  of two adjacent surfaces (print and background) required for the determination of the (Michelson) contrast  $K$  (Formula C.1) can be derived from the knowledge of the reflection properties of the surfaces and the illumination provided by the lighting installation.

$$K = \frac{L_1 - L_2}{L_1 + L_2} \quad (\text{C.1})$$

#### C.2 Back-lit and/or self-lit displays

For back-lit and/or self-lit displays, a luminance  $L_F$ , caused by extraneous light, can superimpose the luminances  $L_1$  and  $L_2$  and reducing the original contrast  $K$ .

NOTE 1 For self-lit displays the luminous densities  $L_1$  (OFF) and  $L_2$  (ON) are determined one after the other at the same position (pixel contrast).

The effective contrast  $K_{\text{eff}}$  (Formula (C.2) then results from the original contrast  $K$  (without extraneous light) as:

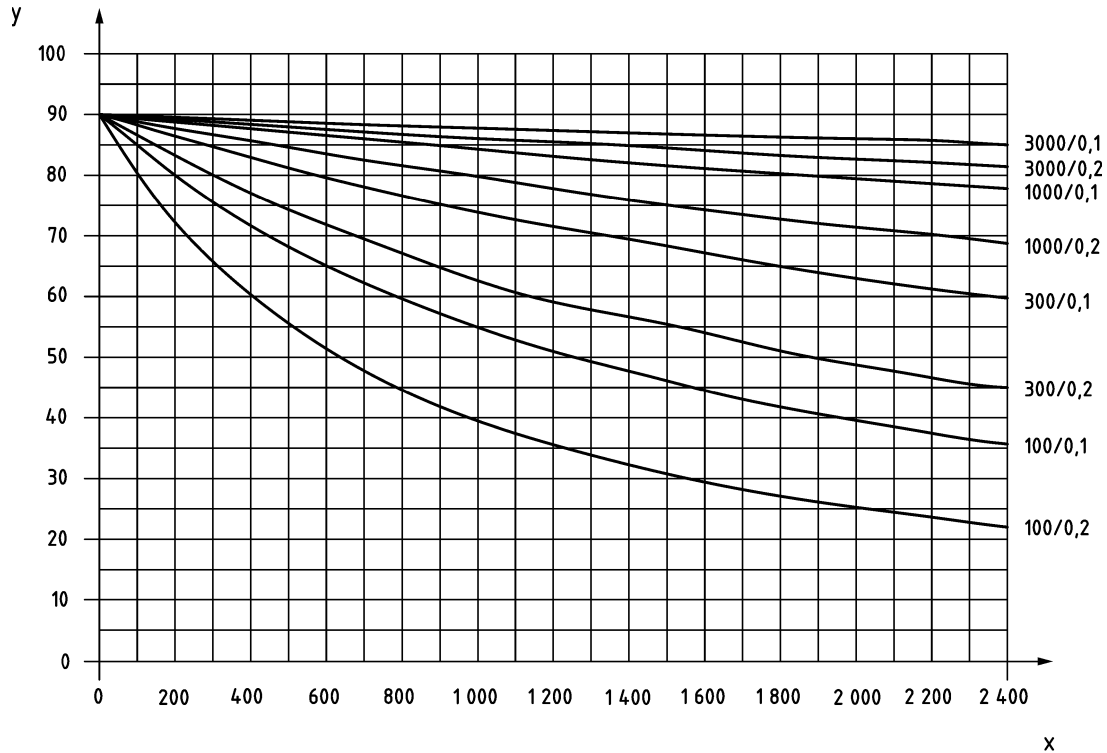
$$K_{\text{eff}} = \frac{L_1 - L_2}{L_1 + L_2 + 2 * L_F} \quad (\text{C.2})$$

Assuming perfect diffuse reflection, the luminance  $L_F$  caused by extraneous light can be determined from the knowledge of the reflectance value  $\rho_A$  and the extraneous illuminance  $E_F$ :

$$L_F = \frac{\rho_A}{\pi} * E_F \quad (\text{C.3})$$

A contrast  $K$  without extraneous light of 0,90 results in an effective contrast  $K_{\text{eff}}$  as a function of the extraneous illuminance  $E_F$  as shown in Figure C.1 for luminances of the lighter surface of 100 cd/m<sup>2</sup>, 300 cd/m<sup>2</sup>, 1 000 cd/m<sup>2</sup> and 3 000 cd/m<sup>2</sup> and assumed reflectances  $\rho_A$  of 0,10 and 0,20.

The contrast required for the representation of information consisting of letters and signals shall be observed for displays fastened in interiors without the effect of daylight at least up to a vertical extraneous brightness of 200 lx and for outdoor installation at least up to an extraneous illuminance of 2 000 lx.



**Key**

- X brightness of extraneous light (lx)
- Y effective contrast

**Figure C.1 — Effective contrast as a function of the extraneous light brightness (lx) for selected combinations of sign luminance (cd/m<sup>2</sup>) and reflectance value. Initial contrast  $K = 0,9$**

NOTE 2 The illustrated contrast reduction by the reflection of extraneous light at the surfaces of the self-lit displays is based on the assumption of constant initial luminous densities. For energy saving purposes on one hand and for the prevention of blooming on the other hand, self-lit displays are increasingly brightness-controlled. For transfective displays high extraneous illuminances can be used to increase the initial illuminance, which counteract the contrast reduction.

NOTE 3 In outside areas self-lit displays are often provided with a protective pane (e.g. to protect them from humidity and dust). In this case the additional reflection given by this protective pane can be taken into account in the examination of contrast conditions.

NOTE 4 This method is an extract from DIN 32975:2009

## Annex D (normative)

### EC verification

#### D.1 Interoperability constituents

##### D.1.1 Conformity assessment

An EC declaration of conformity or suitability for use shall be drawn up by the manufacturer or his authorized representative established in the Union before placing an interoperability constituent on the market.

The conformity assessment of an interoperability constituent shall be according to the prescribed module(s) of that particular constituent specified in D.1.2 of this standard.

##### D.1.2 Application of modules

The modules for the EC certification of conformity of interoperability constituents are listed in Table D.1:

**Table D.1 — Modules for EC certification of conformity of interoperability constituents**

Module CA	Internal production control
Module CA1	Internal production control plus product verification by individual examination
Module CA2	Internal production control plus product verification at random intervals
Module CB	EC-Type examination
Module CC	Conformity to type based on internal production control
Module CD	Conformity to type based on quality management system of the production process
Module CF	Conformity to type based on product verification
Module CH	Conformity based on full quality management system
Module CH1	Conformity based on full quality management system plus design examination
Module CV	Type validation by in service experience (Suitability for use)

The manufacturer or his authorized representative established within the Union shall choose one of the modules or module combinations indicated in Table D.2 for the constituent to be assessed:

**Table D.2 — Combination of modules for EC certification of conformity of interoperability constituents**

Clause	Constituents to be assessed	Module						
		CA	CA1 or CA2 <sup>a</sup>	CB +CC	CB +CD	CB +CF	CH <sup>a</sup>	CH1
5.3.5	Toilets (standard and universal)		X	X	X		X	X
5.3.10	Call for aid devices	X		X			X	
5.4	Boarding aids (ramps, lifts and bridging plates)		X		X	X	X	X

<sup>a</sup> Modules CA1, CA2 or CH may be used only in the case of products manufactured according to a design developed and already used to place products on the market before the application of relevant TSIs applicable to those products, provided that the manufacturer demonstrates to the notified body that design review and type examination were performed for previous applications under comparable conditions, and are in conformity with the requirements of the relevant TSI; this demonstration shall be documented, and is considered as providing the same level of proof as module CB or design examination according to module CH1.

## D.2 Subsystems

### D.2.1 EC verification (general)

The EC verification procedure shall be performed according to the prescribed modules(s) specified in point D.2.2 of this standard.

For the infrastructure subsystem, if the applicant demonstrates that tests or assessments of a subsystem or parts of a subsystem are the same or have been successful for previous applications of a design, the notified body shall consider the results of these tests and assessments for the EC verification.

The approval process and the contents of the assessment shall be defined between the applicant and a notified body.

### D.2.2 Procedures for EC verification of a subsystem (modules)

The modules for the EC verification of subsystems are listed in Table D.3:

**Table D.3 — Modules for the EC verification of subsystems**

Module SB	EC-type examination
Module SD	EC verification based on quality management system of the production process
Module SF	EC verification based on product verification
Module SG	EC verification based on unit verification
Module SH1	EC verification based on full quality management system plus design examination

The applicant shall choose one of the modules or module combinations indicated in Table D.4.

**Table D.4 — Combination of modules for the EC verification of subsystems**

<b>Subsystem to be assessed</b>	<b>Module SB+SD</b>	<b>Module SB+SF</b>	<b>Module SG</b>	<b>Module SH1</b>
Rolling stock subsystem	X	X		X
Infrastructure subsystem			X	X

The characteristics of the subsystem to be assessed during the relevant phases are indicated in Annex E, Table E.1 for infrastructure subsystem and Table E.3 for rolling stock subsystem. The applicant shall confirm that each subsystem produced complies with the type.

## Annex E (normative)

### Summary of testing requirements

The sub-system characteristics that shall be assessed in the different phases of design, development and production are marked by 'X' in Table E.1 for the infrastructure subsystem.

**Table E.1 — Test plan for infrastructure requirements**

<b>Assessment of the infrastructure subsystem (constructed and supplied as a single entity)</b>		
<b>Feature to be tested (all sub-clauses included)</b>	<b>Design and development phase</b>	
	<b>Design review and/or design examination</b>	<b>Construction phase</b>
5.2.1 Obstacle-free route	X	(X) <sup>a</sup>
5.2.2 Doors and entrances	X	(X) <sup>a</sup>
5.2.3 Transparent obstacles	X	(X) <sup>a</sup>
5.2.4 Furniture and free-standing devices	X	(X) <sup>a</sup>
5.2.6 Platform danger area and edge of platform	X	(X) <sup>a</sup>
5.2.7 End of platform	X	(X) <sup>a</sup>
<sup>a</sup> As-built drawings shall be provided or a site inspection shall be carried out when the realization differs from the design rules or drawings that were examined.		

The sub-system characteristics that shall be assessed in the different phases of design, development and production are marked by X in Table E.2 for interoperable constituents.

**Table E.2 — Test plan for interoperable constituents**

<b>Interoperability constituents and characteristics to be assessed</b>	<b>Assessment in the following phase</b>			
	<b>Design and development phase</b>			<b>Production phase</b>
	<b>Design review and/or Design examination</b>	<b>Review of manufacturing process</b>	<b>Type test</b>	<b>Verification of conformity to type</b>
5.3.5 Toilets (standard and universal)	X		X	X
5.3.10 Call for aid devices	X		X	X
5.4 Boarding aids (ramps, lifts and bridging plates)	X		X	X



The sub-system characteristics that shall be assessed in the different phases of design, development and production are marked by X in Table E.3 for the rolling stock subsystem.

**Table E.3 — Test Plan for Rolling Stock requirements**

Characteristics to be assessed	Design and development phase		Production phase
	Design review and/or design examination	Type test	Routine test
5.3.1 Seats	X	X	
5.3.2 Doors	X	X	
5.3.5 Toilets (standard and universal)	X		
5.3.6 Customer information	X	X	
5.3.7 Height changes	X		
5.3.8 Handrails	X	X	
5.3.9 Access/egress steps	X		
5.4 Boarding aids (ramps, lifts and bridging plates)	X	X	X

## **Annex F** (informative)

### **Supporting information from published documents**

#### **F.1 General**

This annex contains extracts from several published documents that support the requirements and assessment methodologies in this standard.

#### **F.2 CIE Publication 196:2011 CIE Guide to Increasing Accessibility in Light and Lighting**

Extract from applicable document that gives information to support assessment.

##### *4.2.3 Special considerations for fonts used in display screens*

*Visual appearance of images in self-luminous screen displays is different from those reflected in printed medium (hard copy documents, books, etc.), and the difference shall be taken into consideration for the display design. In particular, colour appearance of self-luminous displays differs from that of reflected images even if the physical characteristics of the light are the same.*

*Some reference values for the display design have been reported. For example, contrast values between 6:1 and 10:1 are preferred for display screens in DIN/TR 124, while 3:1 is recommended in ISO 9241-303 for screens.*

#### **F.3 ADA Accessibility Guidelines for Buildings and Facilities**

Extract from applicable document that gives information to support contrast requirements and signage.

*703.5 Finish and Contrast: Characters and their background shall have a non-glare finish. Characters shall contrast with their background with either light characters on a dark background or dark characters on a light background.*

*Signs are more legible for persons with low vision when characters contrast as much as possible with their background. Additional factors affecting the ease with which the text can be distinguished from its background include shadows cast by lighting sources, surface, glare and the uniformity of the text and its background colours and textures.*

#### **F.4 BS 8300 2009 Design of buildings and their approaches to meet the needs of disabled people – Code of practice**

Extract from applicable documentation that gives information on LRVs and visual contrast requirements.

*For people with good vision, differences in hue (the nature of the colour) or chroma (the intensity of the colour) provide adequate visual contrast. Unfortunately, this is not the case for all blind and partially sighted people. The main feature of a surface, which appears to be strongly correlated with the ability of blind and partially sighted people to identify differences in colour, is the amount of light the surface reflects, or its light reflectance value (LRV).*

*The LRV scale runs from 0, which is a perfectly absorbing surface that could be assumed to be totally black, up to 100, which is a perfectly reflective surface that could be considered to be the perfect white.*

Because of practical influences in any application, black is always greater than 0 and white never equals 100. For a definition of light reflectance value, see 3.12.

**Annex ZA**  
(informative)

**Relationship between this European Standard and the Essential Requirements of EU Directive 2008/57/EC aimed to be covered**

This European Standard has been prepared under a Commission's standardization request M/483 to provide one voluntary means of conforming to the Essential Requirements of the Directive 2008/57/EC on the interoperability of the rail system (recast) and with the associated TSIs.

Once this standard is cited in the Official Journal of the European Union under that Directive 2008/57/EC, compliance with the normative clauses of this standard given in Table ZA.1 for PRM TSI confers, within the limits of the scope of this standard, a presumption of conformity with the corresponding Essential Requirements of that Directive and associated EFTA regulations and with the TSI requirements.

**Table ZA.1 — Correspondence between this European Standard, the Commission Regulation (EU) No 1300/2014 of 18 November 2014 on the technical specifications for interoperability relating to accessibility of the Union's rail system for persons with disabilities and persons with reduced mobility and repealing Decision 2008/164/EC (published in the Official Journal L 356, 12.12.2014, p.110) and Directive 2008/57/EC**

Clauses/subclauses of this European Standard	Chapter/§/annexes of the Technical Specification for Interoperability (TSI)	Corresponding text, articles/§/annexes of the Directive 2008/57/EC	Comments
Clauses 3, 4, 5, 6 Annexes A, B, C, D, E	4. Characterization of the subsystems 4.2. Functional and technical specifications 4.2.1. Infrastructure subsystem 4.2.2. Rolling Stock subsystem  5. Interoperability constituents 5.3 List and characteristics of constituents 5.3.1 Infrastructure 5.3.2 Rolling stock  6. Assessment of conformity and/or suitability for use 6.1 Interoperability constituents 6.2. Subsystems  Appendix D: Assessment of interoperability constituents Appendix E: Assessment of the subsystems Appendix N: PRM Signage	Annex III, Essential Requirements 1 General requirements 1.1 Safety Clauses 1.1.1, 1.1.5 1.2 Reliability and availability 1.3 Health 1.6 Accessibility Clause 1.6.1  2 Requirements specific to each subsystem 2.1 Infrastructure Clauses 2.1.1, 2.1.2 2.4 Rolling stock Clauses 2.4.1§4, 5, 6, 7, 8, 9, 10, 2.4.2, 2.4.3, 2.4.5	The Essential Requirements incorporate those relating to Accessibility added to Directive 2008/57/EC by Commission Directive 2013/9/EU.  The specific contrast requirements for signage are stated in appendix N (N.3) of the TSI.

**WARNING 1** — Presumption of conformity stays valid only as long as a reference to this European Standard is maintained in the list published in the Official Journal of the European Union. Users of this standard should consult frequently the latest list published in the Official Journal of the European Union.

**WARNING 2** — Other Union legislation may be applicable to the products falling within the scope of this standard.

## Bibliography

- [1] Commission Regulation (EU) No 1300/2014 of 18 November 2014 on the technical specifications for interoperability relating to accessibility of the Union's rail system for persons with disabilities and persons with reduced mobility; OJEU L 356, 12.12.2014
- [2] EN 14752, *Railway applications — Body side entrance systems for rolling stock*
- [3] EN 16585-3:2017, *Railway applications — Design for PRM use — Equipment and components on board rolling stock — Part 3: Clearways and internal doors*
- [4] EN ISO 105-B05, *Textiles — Tests for colour fastness - Part B05: Detection and assessment of photochromism (ISO 105-B05)*
- [5] EN ISO 9241-303, *Ergonomics of human-system interaction — Part 303: Requirements for electronic visual displays (ISO 9241-303)*
- [6] ISO 3864-1, *Graphical symbols — Safety colours and safety signs — Part 1: Design principles for safety signs and safety markings*
- [7] ISO 3864-4, *Graphical symbols — Safety colours and safety signs — Part 4: Colorimetric and photometric properties of safety sign materials*
- [8] ISO 7001:2007, *Graphical symbols — Public information symbols*
- [9] ISO/TR 7239, *Development and principles for application of public information symbols*
- [10] ISO 9186-1, *Graphical symbols — Test methods — Part 1: Method for testing comprehensibility*
- [11] ISO 9186-2, *Graphical symbols — Test methods — Part 2: Method for testing perceptual quality*
- [12] Americans with Disabilities Act ADA *Standards for accessible design 2010*
- [13] BS 8300:2009+A1:2010, *Design of buildings and their approaches to meet the needs of disabled people — Code of practice*
- [14] BS 8475, *Instrumental colour measurement of textiles — Method*
- [15] BS 8493:2008+A1:2010, *Light Reflectance Value (LRV) of a Surface — Method of test*
- [16] DIN 32975:2009, *Designing visual information in the public area for accessible use*
- [17] DIN/TR 124, *Products in design for all*
- [18] DIN 5036-3, *Radiometric and photometric properties of materials; methods of measurement for photometric and spectral radiometric characteristics*
- [19] CIE 15:2004 *Colorimetry*
- [20] CIE 130, *Practical methods for the measurement of reflectance and transmittance*

[21] CIE Publication 196:2011 “CIE Guide to Increasing Accessibility in Light and Lighting”







# British Standards Institution (BSI)

BSI is the national body responsible for preparing British Standards and other standards-related publications, information and services.

BSI is incorporated by Royal Charter. British Standards and other standardization products are published by BSI Standards Limited.

## About us

We bring together business, industry, government, consumers, innovators and others to shape their combined experience and expertise into standards-based solutions.

The knowledge embodied in our standards has been carefully assembled in a dependable format and refined through our open consultation process. Organizations of all sizes and across all sectors choose standards to help them achieve their goals.

## Information on standards

We can provide you with the knowledge that your organization needs to succeed. Find out more about British Standards by visiting our website at [bsigroup.com/standards](http://bsigroup.com/standards) or contacting our Customer Services team or Knowledge Centre.

## Buying standards

You can buy and download PDF versions of BSI publications, including British and adopted European and international standards, through our website at [bsigroup.com/shop](http://bsigroup.com/shop), where hard copies can also be purchased.

If you need international and foreign standards from other Standards Development Organizations, hard copies can be ordered from our Customer Services team.

## Copyright in BSI publications

All the content in BSI publications, including British Standards, is the property of and copyrighted by BSI or some person or entity that owns copyright in the information used (such as the international standardization bodies) and has formally licensed such information to BSI for commercial publication and use.

Save for the provisions below, you may not transfer, share or disseminate any portion of the standard to any other person. You may not adapt, distribute, commercially exploit, or publicly display the standard or any portion thereof in any manner whatsoever without BSI's prior written consent.

## Storing and using standards

Standards purchased in soft copy format:

- A British Standard purchased in soft copy format is licensed to a sole named user for personal or internal company use only.
- The standard may be stored on more than 1 device provided that it is accessible by the sole named user only and that only 1 copy is accessed at any one time.
- A single paper copy may be printed for personal or internal company use only.

Standards purchased in hard copy format:

- A British Standard purchased in hard copy format is for personal or internal company use only.
- It may not be further reproduced – in any format – to create an additional copy. This includes scanning of the document.

If you need more than 1 copy of the document, or if you wish to share the document on an internal network, you can save money by choosing a subscription product (see 'Subscriptions').

## Reproducing extracts

For permission to reproduce content from BSI publications contact the BSI Copyright & Licensing team.

## Subscriptions

Our range of subscription services are designed to make using standards easier for you. For further information on our subscription products go to [bsigroup.com/subscriptions](http://bsigroup.com/subscriptions).

With **British Standards Online (BSOL)** you'll have instant access to over 55,000 British and adopted European and international standards from your desktop. It's available 24/7 and is refreshed daily so you'll always be up to date.

You can keep in touch with standards developments and receive substantial discounts on the purchase price of standards, both in single copy and subscription format, by becoming a **BSI Subscribing Member**.

**PLUS** is an updating service exclusive to BSI Subscribing Members. You will automatically receive the latest hard copy of your standards when they're revised or replaced.

To find out more about becoming a BSI Subscribing Member and the benefits of membership, please visit [bsigroup.com/shop](http://bsigroup.com/shop).

With a **Multi-User Network Licence (MUNL)** you are able to host standards publications on your intranet. Licences can cover as few or as many users as you wish. With updates supplied as soon as they're available, you can be sure your documentation is current. For further information, email [subscriptions@bsigroup.com](mailto:subscriptions@bsigroup.com).

## Revisions

Our British Standards and other publications are updated by amendment or revision.

We continually improve the quality of our products and services to benefit your business. If you find an inaccuracy or ambiguity within a British Standard or other BSI publication please inform the Knowledge Centre.

## Useful Contacts

### Customer Services

**Tel:** +44 345 086 9001

**Email (orders):** [orders@bsigroup.com](mailto:orders@bsigroup.com)

**Email (enquiries):** [cservices@bsigroup.com](mailto:cservices@bsigroup.com)

### Subscriptions

**Tel:** +44 345 086 9001

**Email:** [subscriptions@bsigroup.com](mailto:subscriptions@bsigroup.com)

### Knowledge Centre

**Tel:** +44 20 8996 7004

**Email:** [knowledgecentre@bsigroup.com](mailto:knowledgecentre@bsigroup.com)

### Copyright & Licensing

**Tel:** +44 20 8996 7070

**Email:** [copyright@bsigroup.com](mailto:copyright@bsigroup.com)

### BSI Group Headquarters

389 Chiswick High Road London W4 4AL UK