

BS EN 16471:2014



BSI Standards Publication

Firefighters helmets — Helmets for wildland fire fighting

bsi.

...making excellence a habit.™

National foreword

This British Standard is the UK implementation of EN 16471:2014.

The UK participation in its preparation was entrusted to Technical Committee PH/6/3, Firefighters' helmets.

A list of organizations represented on this committee can be obtained on request to its secretary.

This publication does not purport to include all the necessary provisions of a contract. Users are responsible for its correct application.

© The British Standards Institution 2014.
Published by BSI Standards Limited 2014

ISBN 978 0 580 79312 7

ICS 13.340.20

Compliance with a British Standard cannot confer immunity from legal obligations.

This British Standard was published under the authority of the Standards Policy and Strategy Committee on 31 December 2014.

Amendments/corrigenda issued since publication

Date	Text affected
------	---------------

ICS 13.340.20

English Version

Firefighters helmets - Helmets for wildland fire fighting

Casques de sapeurs-pompiers - Casques pour la lutte
contre les feux d'espaces naturels

Feuerwehrhelme - Helme für Wald- und
Flächenbrandbekämpfung

This European Standard was approved by CEN on 2 November 2014.

CEN members are bound to comply with the CEN/CENELEC Internal Regulations which stipulate the conditions for giving this European Standard the status of a national standard without any alteration. Up-to-date lists and bibliographical references concerning such national standards may be obtained on application to the CEN-CENELEC Management Centre or to any CEN member.

This European Standard exists in three official versions (English, French, German). A version in any other language made by translation under the responsibility of a CEN member into its own language and notified to the CEN-CENELEC Management Centre has the same status as the official versions.

CEN members are the national standards bodies of Austria, Belgium, Bulgaria, Croatia, Cyprus, Czech Republic, Denmark, Estonia, Finland, Former Yugoslav Republic of Macedonia, France, Germany, Greece, Hungary, Iceland, Ireland, Italy, Latvia, Lithuania, Luxembourg, Malta, Netherlands, Norway, Poland, Portugal, Romania, Slovakia, Slovenia, Spain, Sweden, Switzerland, Turkey and United Kingdom.



EUROPEAN COMMITTEE FOR STANDARDIZATION
COMITÉ EUROPÉEN DE NORMALISATION
EUROPÄISCHES KOMITEE FÜR NORMUNG

CEN-CENELEC Management Centre: Avenue Marnix 17, B-1000 Brussels

Contents	Page
Foreword.....	4
1 Scope	5
2 Normative references	5
3 Terms and definitions	6
4 Physical requirements	6
4.1 Materials	6
4.2 Projections	7
4.3 Retention system	7
4.4 Accessories and non-integral additional protective devices.....	7
5 Performance requirements	8
5.1 Extent of Coverage	8
5.2 Shock absorption.....	8
5.2.1 Crown impact	8
5.2.2 Lateral impacts (front, side, rear).....	8
5.3 Penetration resistance	8
5.4 Retention system effectiveness	8
5.5 Retention system strength	8
5.6 Flame resistance.....	8
5.6.1 Helmet shell.....	8
5.6.2 Retention system	8
5.6.3 Accessories and no integral additional protective devices	8
5.7 Radiant heat protection / thermal stress	9
5.8 Thermal resistance	9
5.9 Resistance to hot solids	9
5.10 Field of vision.....	9
5.11 Practical performance	10
5.11.1 General.....	10
5.11.2 Requirements	10
6 Test methods.....	10
6.1 Sampling and helmet adjustment	10
6.1.1 Sampling.....	10
6.1.2 Helmet adjustment.....	10
6.2 Visual inspection	11
6.3 Conditioning.....	11
6.3.1 General.....	11
6.3.2 Cleaning and disinfection	11
6.3.3 Ultraviolet (UV) ageing	11
6.3.4 “Thermal plus” conditioning	11
6.3.5 “Thermal minus” conditioning	11
6.3.6 Wet conditioning.....	11
6.4 Extent of coverage.....	11
6.4.1 Equipment	11
6.4.2 Samples	11
6.4.3 Test method.....	11
6.5 Shock absorption.....	12
6.5.1 General.....	12
6.5.2 Crown impact	12
6.5.3 Lateral impacts (front, side, rear).....	12

6.6	Penetration resistance	12
6.7	Retention system effectiveness	12
6.8	Retention system strength	12
6.9	Flame resistance	13
6.9.1	Helmet shell and items	13
6.9.2	Helmet retention system components	13
6.10	Radiant heat protection/thermal stress	13
6.11	Thermal resistance	13
6.12	Resistance to hot solids	13
6.13	Field of vision	13
6.14	Practical performance testing	13
6.14.1	Test subjects and conditions	13
6.14.2	Procedure	14
6.14.3	Test report	15
6.14.4	Variants	15
7	Marking	15
8	Information to be supplied by the manufacturer	16
Annex A (normative) Conditioning and testing schedule		18
Annex ZA (informative) Relationship between this European Standard and the Essential Requirements of EU Directive 89/686/EEC		20

Foreword

This document (EN 16471:2014) has been prepared by Technical Committee CEN/TC 158 “Head protection”, the secretariat of which is held by BSI.

This European Standard shall be given the status of a national standard, either by publication of an identical text or by endorsement, at the latest by June 2015 and conflicting national standards shall be withdrawn at the latest by June 2015.

Attention is drawn to the possibility that some of the elements of this document may be the subject of patent rights. CEN [and/or CENELEC] shall not be held responsible for identifying any or all such patent rights.

This document has been prepared under a mandate given to CEN by the European Commission and the European Free Trade Association, and supports essential requirements of EU Directive(s).

For relationship with EU Directive(s), see informative Annex ZA, which is an integral part of this document.

The purpose of this European Standard is to provide minimum performance requirements for helmets designed for use for extended periods during wildland fire fighting and associated activities.

Wildland fire fighting involves work primarily in summer temperatures, for many hours during which the fire fighter may develop high levels of metabolic heat. Consequently, the protective helmet should be comfortable, light and commensurate with the risks to which the fire fighter may be exposed in order to be effective without introducing heat stress to the wearer.

This European Standard does not cover helmets for use in situations where helmets conforming to EN 443 are more suitable.

According to the CEN-CENELEC Internal Regulations, the national standards organizations of the following countries are bound to implement this European Standard: Austria, Belgium, Bulgaria, Croatia, Cyprus, Czech Republic, Denmark, Estonia, Finland, Former Yugoslav Republic of Macedonia, France, Germany, Greece, Hungary, Iceland, Ireland, Italy, Latvia, Lithuania, Luxembourg, Malta, Netherlands, Norway, Poland, Portugal, Romania, Slovakia, Slovenia, Spain, Sweden, Switzerland, Turkey and the United Kingdom.

1 Scope

This European Standard specifies the minimum requirements for wildland fire fighting helmets protecting the upper head mainly against the effects of impact, penetration, heat, flame and burning embers while conducting fire fighting and associated activities in wildland environments. Requirements for marking and information to be supplied by the manufacturer are included. Wildland fire fighting involves direct and indirect attack techniques (like wood cutting).

Wildland environments include forests, crops, plantations and grass/heath/scrub or farmland.

Helmets for use while fire fighting in buildings and other structures are not covered by this European Standard (see EN 443). This helmet is not intended to provide protection during fire entrapment.

Protection of the face, eyes, ears and neck may require additional items of personal protective equipment (PPE), which are not covered by this European Standard.

2 Normative references

The following documents, in whole or in part, are normatively referenced in this document and are indispensable for its application. For dated references, only the edition cited applies. For undated references, the latest edition of the referenced document (including any amendments) applies.

EN 168:2001, *Personal eye-protection - Non-optical test methods*

EN 960:2006, *Headforms for use in the testing of protective helmets*

EN 1811, *Reference test method for release of nickel from all post assemblies which are inserted into pierced parts of the human body and articles intended to come into direct and prolonged contact with the skin*

EN 13087-1:2000, *Protective helmets - Test methods - Part 1: Conditions and conditioning*

EN 13087-2, *Protective helmets - Test methods - Part 2: Shock absorption*

EN 13087-3:2000, *Protective helmets - Test methods - Part 3: Resistance to penetration*

EN 13087-4, *Protective helmets - Test methods - Part 4: Retention system effectiveness*

EN 13087-5:2012, *Protective helmets — Test methods — Part 5: Retention system strength*

EN 13087-6, *Protective helmets - Test methods - Part 6: Field of vision*

EN 13087-7:2000, *Protective helmets - Test methods - Part 7: Flame resistance*

EN 13087-10, *Protective helmets - Test methods - Part 10: Resistance to radiant heat*

EN ISO 13688, *Protective clothing - General requirements (ISO 13688)*

ISO 17493, *Clothing and equipment for protection against heat — Test method for convective heat resistance using a hot air circulating oven*

3 Terms and definitions

For the purposes of this document, the following terms and definitions apply.

3.1 helmet for wildland fire fighting
headwear, including all integral components supplied by the manufacturer, intended primarily to protect the upper part of a wearer's head against hazards which may occur during wildland fire fighting activities

Note 1 to entry: Hereafter, helmets for wildland fire fighting are referred to as helmets.

3.2 helmet shell
component in hard material with a smooth finish, which gives the helmet its general shape

3.3 protective padding
material and/or suspension system which serves to dampen impact energy

3.4 retention system
those parts which are responsible for securing the helmet in position on the head, including items which enable adjustment or improved comfort

3.5 chin strap
part of a retention system, including a strap which passes under or on the wearer's chin and which helps to ensure that the helmet is correctly maintained in place

3.6 head form
shape replacing the head which is used for testing certain characteristics

Note 1 to entry: The head form is designed in accordance with EN 960.

3.7 accessories
additional device(s) supplied or recommended by the manufacturer which may be attached to the helmet but which provide no protective function to the wearer

EXAMPLES Lamp brackets, cable clips, badges and trims.

3.8 non-integral additional protective devices
additional protective device(s) supplied or recommended by the manufacturer which may be attached to the helmet and intended to be removable by the user

EXAMPLES Mesh visors, ear defenders, neck-guard and safety goggles.

4 Physical requirements

4.1 Materials

For those parts of the helmet coming, or that may come, into contact with the skin the material used shall not be subject to any known appreciable alteration from contact with sweat or with substances likely to be found in toiletries. Materials shall not be used which are known to cause skin disorders or other adverse effects on health.

Examples of documents, which can be presented as evidence of chemical innocuousness, are given in the note.

NOTE The following list of documents is given for information and as examples of documents to be examined:

- a) materials specifications;
- b) safety data sheets relating to the materials;
- c) information relating to the suitability of the materials for use with food, in medical devices, or other relevant applications;
- d) information relating to toxicological, allergenic, carcinogenic, toxic to reproduction or mutagenic investigations on the materials;
- e) information relating to ecotoxicological and other environmental investigations on the materials.

The examination should determine whether the claim that the materials are suitable for use in the protective helmet is justified. Particular attention needs to be paid to the presence of plasticisers, unreacted components, heavy metals, impurities and the chemical identity of pigments and dyes.

All metallic materials which could come into prolonged contact with the skin (e.g. studs, fittings) shall have a release of Nickel of less than $0,5 \mu\text{g}/\text{cm}^3$ per week, when tested according to EN 1811.

Substances recommended for cleaning, maintenance or disinfection shall have no adverse effect on the helmet and shall be not known to be likely to have any adverse effect upon the wearer, when applied in accordance with the manufacturer's instructions.

Materials shall conform to the relevant requirements of EN ISO 13688.

4.2 Projections

There shall be no sharp edges, roughness or projections on any part of the helmet, which are likely to cause injury to the wearer, in contact or potential contact with the wearer when the helmet is worn. Test according to 6.14.

4.3 Retention system

The helmet shall be fitted with a retention system, including a chinstrap. The chinstrap shall be adjustable in length.

4.4 Accessories and non-integral additional protective devices

When the helmet manufacturer states any accessories and/or non-integral additional protective devices, as defined in 3.7 and 3.8, as being for use with the helmet, the helmet with such items fitted to it shall continue to satisfy the requirements of this European Standard.

However, some accessories and/or non-integral additional protective devices may not be suitable for wildland fire fighting and only suitable for non-fire fighting associated activities such as wood cutting, road clearance, etc. In such cases, information shall be provided by the manufacturer as to the conditions under which such accessories and/or non-integral additional protective devices may be used.

If accessories and non-integral additional protective devices are supplied and/or recommended by the helmet manufacturer they shall individually conform to the requirements of the appropriate standard related to that specific device.

5 Performance requirements

5.1 Extent of Coverage

When the helmet is tested by the method described in 6.4, it shall cover at least area situated above plane AA' as defined in EN 960:2006, Figure 1.

5.2 Shock absorption

5.2.1 Crown impact

When a helmet is tested by the method described in 6.5.2, the force transmitted to the head form shall not exceed 5 kN, for an impact energy of (50 ± 2) J.

5.2.2 Lateral impacts (front, side, rear)

When a helmet is tested by the method described in 6.5.3, the force transmitted to the head form shall not exceed 5 kN, for an impact energy of (25 ± 1) J.

5.3 Penetration resistance

When a helmet is tested by the method described in 6.6, there shall be no contact between the striker and the test block, for an impact energy of (30 ± 1) J.

5.4 Retention system effectiveness

When a helmet is tested by the method described in 6.7, the helmet shall not come completely off the head form.

5.5 Retention system strength

When a helmet is tested by the method described in 6.8, the following shall apply:

- a) Maximum dynamic elongation shall not exceed 25 mm under the intermediate load condition;
- b) Minimum width of the chin strap under intermediate load condition shall be 15 mm;
- c) The release point of the retention system shall be between 500 N and 1 000 N.

5.6 Flame resistance

5.6.1 Helmet shell

When a helmet is tested by the method given in 6.9.1, any of the externally exposed materials of the helmet shell, not within 5 mm of an edge, shall not burn with the emission of flame or drip molten material after a period of 5 s has elapsed from removal of the flame.

5.6.2 Retention system

Materials of the retention system that are outside of the helmet shell, when tested by the method given in 6.9.2, shall not burn with the emission of flame or drip molten material after a period of 5 s has elapsed from the removal of the flame.

5.6.3 Accessories and non-integral additional protective devices

Any items as defined in 3.7 and 3.8 stated as being for use with the helmet by the helmet manufacturer for wildland firefighting and associated operations and on the outside of the helmet shell, shall be tested by the

method given in 6.9.1 in their in-use position. The flame shall not be applied within 5 mm of any edge of the item and the item shall not burn with the emission of flame or drip molten material after a period of 5 s has elapsed from the removal of the flame.

5.7 Radiant heat protection / thermal stress

When a helmet is tested by the method given in 6.10, the following requirements shall be met during all heating cycles;

- a) the temperature inside the helmet shall not increase by more than 25 °C;
- b) no material shall ignite or melt to such a degree as to cause softening or dripping of material so that material that is not in contact with the head form before this test comes into contact with the head form as a result of this test. Test by visual inspection.

If the helmet manufacturer states any accessories and/or non-integral additional protective devices as defined in 3.7 and 3.8 as being for use with the helmet for wildland fire fighting, the helmet with such items fitted to it, in their in-use position shall also satisfy these requirements.

Upon completion of 3 heating cycles and testing according to 6.10, the helmet shall conform to the impact test requirements according to 5.2.1.

5.8 Thermal resistance

When the helmet is tested by the method given in 6.11, it shall conform to the following requirements:

- a) no material that is not in contact with the head form before this test shall come into contact with the head form as a result of this test. Test by visual inspection;
- b) there shall be no separation, melting or dripping of material;
- c) any moveable elements shall remain functional;
- d) there shall be no ignition of any material; and
- e) there shall be no ignition, melting or loss of legibility of the product labels.

If the helmet manufacturer states that any accessories and/or non-integral additional protective devices, as defined in 3.7 and 3.8, as being for use with the helmet for wildland firefighting, the helmet with such items fitted to it in their in-use position shall also satisfy these requirements.

5.9 Resistance to hot solids

No complete penetration, burning, or molten drip of the helmet shell shall occur within 7 s when a helmet is tested by the method given in 6.12.

5.10 Field of vision

When the helmet is tested in accordance with 6.13, the wearer's field of vision shall correspond to the following angles:

- a) horizontal field of vision of not less than 105° on both right and left sides;
- b) vertical field of vision in the upwards direction of not less than 7°;
- c) vertical field of vision in the downwards direction of not less than 45°; and

- d) the specified field of vision shall be achieved with any eye protector in the in-use and out-of-use positions.
- e) The periphery of the eye protector may fall within the specified field of vision.

The eye protector should not restrict the users awareness of the surroundings.

5.11 Practical performance

5.11.1 General

Samples used for practical performance shall be supplied separately by the manufacturer in the appropriate sizes and shall not be utilized for any of the laboratory testing identified in Annex A.

- a) The testing is a subjective assessment of the helmet by the test subject (wearer) and the observer during the trial.
- b) A record of the observer's and test subject's comments shall be made after the trial – see 6.14.3.
- c) Clothing and footwear chosen shall not compromise any of the activities to be undertaken during the practical performance testing.

5.11.2 Requirements

When the helmet is assessed in accordance with 6.14 the following requirements shall be met:

- a) it shall be possible for the helmet to be adjusted to give a snug fit to the head of the 5 test subjects;
- b) the helmet shall always remain in place during the activities listed under 6.14.2;
- c) there shall not be any "NO" answers from any of the 5 test subjects; and
- d) the removal time during doffing of the helmet shall be < 5 s.

6 Test methods

6.1 Sampling and helmet adjustment

6.1.1 Sampling

Helmets shall be submitted for testing in the condition in which they are offered for sale, including any requisite holes or other means of attachment, for any item(s) as defined in the manufacturer's instructions.

If several sizes of helmet are available then the size representing the most unfavourable helmet in relation to headform size shall be used. See Annex A.

6.1.2 Helmet adjustment

Before any testing on a headform, the helmet shall be adjusted in accordance with the manufacturer's instructions.

The headforms for use in this European Standard shall be sizes 495, 535, 575, 605 and 625 conforming to EN 960:2006, as appropriate to the test performed. If the wearing adjustment covers several sizes of headform then the size of headform representing the most unfavourable case shall be used. See Annex A.

6.2 Visual inspection

A visual inspection shall be conducted prior to laboratory testing. This shall consist of an assessment of the device marking and information supplied by the manufacturer and any safety data sheets or declarations relevant to the materials used in its construction. Particular attention needs to be paid to the presence of plasticisers, unreacted components, heavy metals, impurities and the chemical identity of pigments and dyes. [EN ISO 13688, 4.2 Innocuousness] This may entail a certain amount of dismantling in accordance with the manufacturer's instructions for maintenance. If this occurs this helmet shall not be used for further testing.

6.3 Conditioning

6.3.1 General

Before any testing is performed, the helmet shall be conditioned in accordance with the conditioning sequences given in Annex A and the relevant specifications defined in 6.3.2 to 6.3.6:

6.3.2 Cleaning and disinfection

The helmet shall be cleaned and disinfected 5 times according to the manufacturer's instructions.

6.3.3 Ultraviolet (UV) ageing

The helmet shall be preconditioned in accordance with EN 13087-1:2000, 4.7.

6.3.4 "Thermal plus" conditioning

The helmet shall be preconditioned at +50 °C in accordance with EN 13087-1:2000, 4.4

6.3.5 "Thermal minus" conditioning

The helmet shall be preconditioned in accordance with EN 13087-1:2000, 4.5. The temperature selected shall be one of the following; -10 °C, -20 °C, -30 °C or -40 °C as identified in the marking in Clause 7, g), below.

6.3.6 Wet conditioning

The helmet shall be preconditioned in accordance with EN 13087-1:2000, 4.6, Method 1.

6.4 Extent of coverage

6.4.1 Equipment

- a) Headforms of sizes 495, 535, 575, 605 and 625 conforming to EN 960:2006,
- b) ballast mass of $(5,0 \pm 0,5)$ kg.

6.4.2 Samples

One sample shall be tested for each size combination of shell and retention system.

6.4.3 Test method

From the size range stated by the manufacturer for the given combination of shell and retention system, select the largest headform appropriate to that range.

Fit the helmet on the test headform in accordance with the information supplied by the manufacturer and ensure that the longitudinal vertical median plane of the helmet coincides with the longitudinal vertical median plane of the headform.

Place and centre the ballast mass on the crown of the helmet and stabilize it in position.

Determine whether the helmet provides coverage to the appropriate area.

Repeat the determination to ensure any moveable integral corrective eye protector is tested in both in-use and out-of-use positions.

6.5 Shock absorption

6.5.1 General

All four impacts (1 crown and 3 lateral) shall be performed on the same helmet as shown in Annex A. The impact shall be performed following the order (1-2-3-4) as shown in Figure 1.

The first impact shall be performed within one minute of removal from conditioning and subsequent impacts within five minutes, readjusting the helmet on the headform if necessary.

6.5.2 Crown impact

The helmet shall be tested in accordance with EN 13087-2 falling mass method, using the hemispherical striker.

The head form shall be rotated so that the impact point lies along the axis through the striker and transducer.

Allow the striker to fall on to impact point 1 as shown in Figure 1.

6.5.3 Lateral impacts (front, side, rear)

The helmet shall be tested in accordance with EN 13087-2, falling mass method, using the flat striker and impact points 2, 3, 4 as shown in Figure 1. Testing shall ensure that both left and right lateral positions are tested across the three samples 1 to 3 (see Annex A).

6.6 Penetration resistance

The helmet shall be tested in accordance with EN 13087-3 using the conical striker. The helmet shall be tested on two points of impact, separated from each other by a distance of at least 50 mm, within a circle having a radius of 50 mm, centred on point 1 shown in Figure 1.

The first impact shall be performed within one minute of removal from conditioning and the second impact within five minutes.

6.7 Retention system effectiveness

The helmet shall be tested in accordance with both the front and rear pull directions of EN 13087-4.

Rear and front pull tests shall be performed on a single helmet as specified in Annex A. The drop height shall be (175 ± 5) mm.

6.8 Retention system strength

The helmet shall be tested in accordance with EN 13087-5:2012, 5.2, Method b.

The helmet shell shall be fixed relative to the headform to prevent shell movement during retention system strength testing.

The initial tensile force shall be 30 N and the intermediate force shall be 250 N.

The chinstrap width shall be measured one minute after initial application of the intermediate force.

6.9 Flame resistance

6.9.1 Helmet shell and items

The helmet shell and items, as defined in 3.7 and 3.8, shall be tested in accordance with EN 13087-7, using a flame application time of 15 s.

6.9.2 Helmet retention system components

The helmet retention system components shall be tested in accordance with EN 13087-7:2000, using a flame application time of 10 s.

6.10 Radiant heat protection/thermal stress

The helmet shall be tested in accordance with EN 13087-10 with the following modifications.

Heat applied shall be 7 kW/m^2 for 1 min, and the heat flux shall be applied in the region of point 1 (crown impact) of Figure 1.

The impact test to be performed is that described in 6.5.2, and shall take place once 3 heat application cycles have been completed allowing natural cooling to ambient temperature between tests. The next heat application cycle cannot start until the sensor system is also at ambient temperature.

Impact shall be performed within 60 s after the last heat application cycle has been completed without waiting for the cooling down period.

Ambient temperature is defined in EN 13087-1.

6.11 Thermal resistance

The helmet shall be tested in accordance with ISO 17493 with a temperature of $(90 \pm 5) \text{ }^\circ\text{C}$ for 20 min.

Any items, as defined in 3.7 and 3.8, shall be tested in the 'in-use' position.

6.12 Resistance to hot solids

The helmet shall be tested in accordance with EN 168:2001, Clause 11.

The test shall be carried out on each of the impact points of points 1, 2, 3 or 4 of Figure 1.

6.13 Field of vision

The helmet shall be tested in accordance with EN 13087-6.

6.14 Practical performance testing

6.14.1 Test subjects and conditions

The test team shall consist of 5 different people, at least 1 of either sex, familiar with the equipment and apparatus and different head sizes and forms to cover a broad range of anthropometric conditions.

At least one test subject shall be selected whose head size requires a size between the lower limit of the size range as given by the manufacturer and the lower 25th percentile and at least one test subject shall be selected whose head size requires helmets between the upper limit of the size range as given by the manufacture and the upper 75th percentile.

Each type and size of helmet submitted for testing shall be assessed by one test subject. Five helmets covering at least 3 different head sizes shall be tested, including the largest and smallest available models.

Testing atmosphere shall be according to EN 13087-1:2000, 4.2.

6.14.2 Procedure

6.14.2.1 Pre-donning assessment

The test subjects shall choose the correct size in accordance with the information supplied by the manufacturer. Before donning the helmet the test subject shall fully consult the instructions provided by the manufacturer, examine it and respond to the following questions.

1.	Is the inner and outer design of the helmet including accessories, if applicable, free from rough, sharp or hard areas or features that might cause excessive irritation or injury to the wearer? This assessment shall be made by manual and visual inspection.	YES	NO
----	---	-----	----

If the answer to Question 1 is NO, the assessment shall be stopped at this point and the helmet under test shall be deemed to have failed the assessment.

6.14.2.2 Donning

The test subject shall don the helmet and respond to the following questions.

Once the helmet has been put on, it is permissible for the test subject to “get used to the helmet” for a short time to overcome any initial fitting problems before proceeding with the rest of the assessment.

2.	Is it practical to operate the fastener(s) and/or adjustment parts, e.g. head size or height adjustment etc., of the helmet?	YES	NO
3.	When fitted, is the helmet correctly positioned and is it possible to adjust the length of the chin strap to fit comfortably and secure on the head?	YES	NO
4.	Is it practical to assemble and disassemble the accessories and non-integral additional protective devices? (if applicable)	YES	NO
5.	Is it practical to operate the eye and/or face protector(s) and their adjustment parts? (if applicable)	YES	NO
6.	Is it practical to operate the hearing protector(s) and its adjustment parts? (if applicable)	YES	NO
7.	Is it practical to operate the accessories and their adjustment parts? (if applicable)	YES	NO

6.14.2.3 Mobility

The test subject shall carry out the activities listed and respond to the following question.

Each test sequence should be continuous without removal of the equipment.

Between the test sequences equipment may be removed and refitted. The number of sequences is specified by the different variants of the helmet including any items, as defined in 3.7 and 3.8, that are available and described in the manufacturer’s instruction that affect ergonomics.

8.	Can the following activities be carried out without difficulty and does the helmet remain in place during each activity?		
	a) Walking at (4,0 ± 0,5) km/h for 5 min.	YES	NO
	b) Running rapidly at (9,0 ± 0,5) km/h for 1 min.	YES	NO
	c) Moving the head from side to side and up and down each 10 times while standing and during walking.	YES	NO
	d) Climbing and descending a ladder with a total vertical distance of 10 m.	YES	NO
	e) Laying out a fire hose of at least 15 m and recoiling it.	YES	NO
	f) Bending from the waist with straight legs and picking up a small object from the floor 10 times.	YES	NO

The sequence of activities is at the discretion of the organizer of the trials.

6.14.2.4 Doffing

The test subject shall remove the helmet as quickly as possible once the exercises have all been completed, while being timed, and shall respond to the following question.

Several attempts at removal are permitted to ensure the test subject is fully familiar with the particular fastening system.

9.	Can you easily remove the helmet within 5 s ?	YES	NO
----	---	-----	----

6.14.3 Test report

The following information shall be recorded in the test report:

- a) Details of the item or items being assessed;
- b) The test subject's responses to all the questions listed under 6.14.2;
- c) Details of the ambient temperature and humidity of the test environment

6.14.4 Variants

The testing described in 6.14.2 shall be repeated as necessary to ensure that an assessment is made of the effect of all items defined in 3.7 and 3.8 that are available for the helmet.

7 Marking

Every helmet conforming to this European Standard shall carry a permanent marking legible to the user, without dismantling any element, with the following information:

- a) number of this European Standard;
- b) name or identification mark of manufacturer;
- c) year and quarter of manufacture;
- d) manufacturer's designation for the helmet model, this being marked on both the shell and the retention system;

- e) the 'iBook' symbol to indicate to the user that information such as size range (in cm), material of the shell and harness, etc. can be sourced from the user's instruction manual;
- f) size or size range (in cm);
- g) low temperature classification;
 - i) *for products satisfying the requirements for $-10\text{ }^{\circ}\text{C}$,
 - ii) ** for products satisfying the requirements for $-20\text{ }^{\circ}\text{C}$,
 - iii) *** for products satisfying the requirements for $-30\text{ }^{\circ}\text{C}$, and
 - iv) **** for products satisfying the requirements for $-40\text{ }^{\circ}\text{C}$.

Marking shall be easily visible to the user without requiring disassembly of the helmet or removal of accessories.

8 Information to be supplied by the manufacturer

The following information, provided precisely and comprehensibly in the official language(s) of the country of sale, shall accompany each helmet.

- a) The name and address of the manufacturer and/or his established representative in the community.
- b) Telephone and/or facsimile numbers and/or email address of the manufacturer or his authorized representative.
- c) Instructions or recommendations regarding adjustment, fitting, use, cleaning, disinfection, maintenance, servicing and storage.
- d) Manufacturer's type number, identification number or model number; helmet size ranges; mass of the helmet excluding accessories.
- e) Number and year of this European Standard, i.e. EN 16471:2014.
- f) Details of any items, as defined in 3.7 and 3.8 and appropriate spare parts, including reference to sizes and/or materials where necessary.
- g) Guidance regarding the obsolescence deadline or period of obsolescence of the helmet and its components.
- h) Guidance regarding details of the type of packaging suitable for transportation of the helmet.
- i) Warning that the protection intended to be provided by the helmet can only be ensured when it is properly assembled and correctly fitted, and that any removable part shall not be worn separately.
- j) Statement: "Warning: The validity of the EC type-examination certificate might no longer be satisfied if a helmet marked as conforming to this European Standard is fitted with another item of personal protective equipment or with an accessory (other than as supplied by the helmet manufacturer for use with this helmet)".
- k) Statement: "This helmet conforms to the retention requirements of this European Standard when the chin strap supplied by the helmet manufacturer is worn and adjusted in accordance with these instructions."

- l) Statement: "Helmet absorbs the energy of a blow by partial destruction of, or damage to, the helmet. Even though such damage may not be readily apparent, any helmet subjected to a severe impact should be replaced."
- m) Clearly describe the visual controls to apply regularly, and after each specific event, that are to be used to detect any decrease in the performance of the helmet.

The information should be easily understood and where appropriate, the use of illustrations and part numbers and descriptions is encouraged. Appropriate warnings or answers to frequently asked questions should be provided to assist the user to use the helmet correctly.

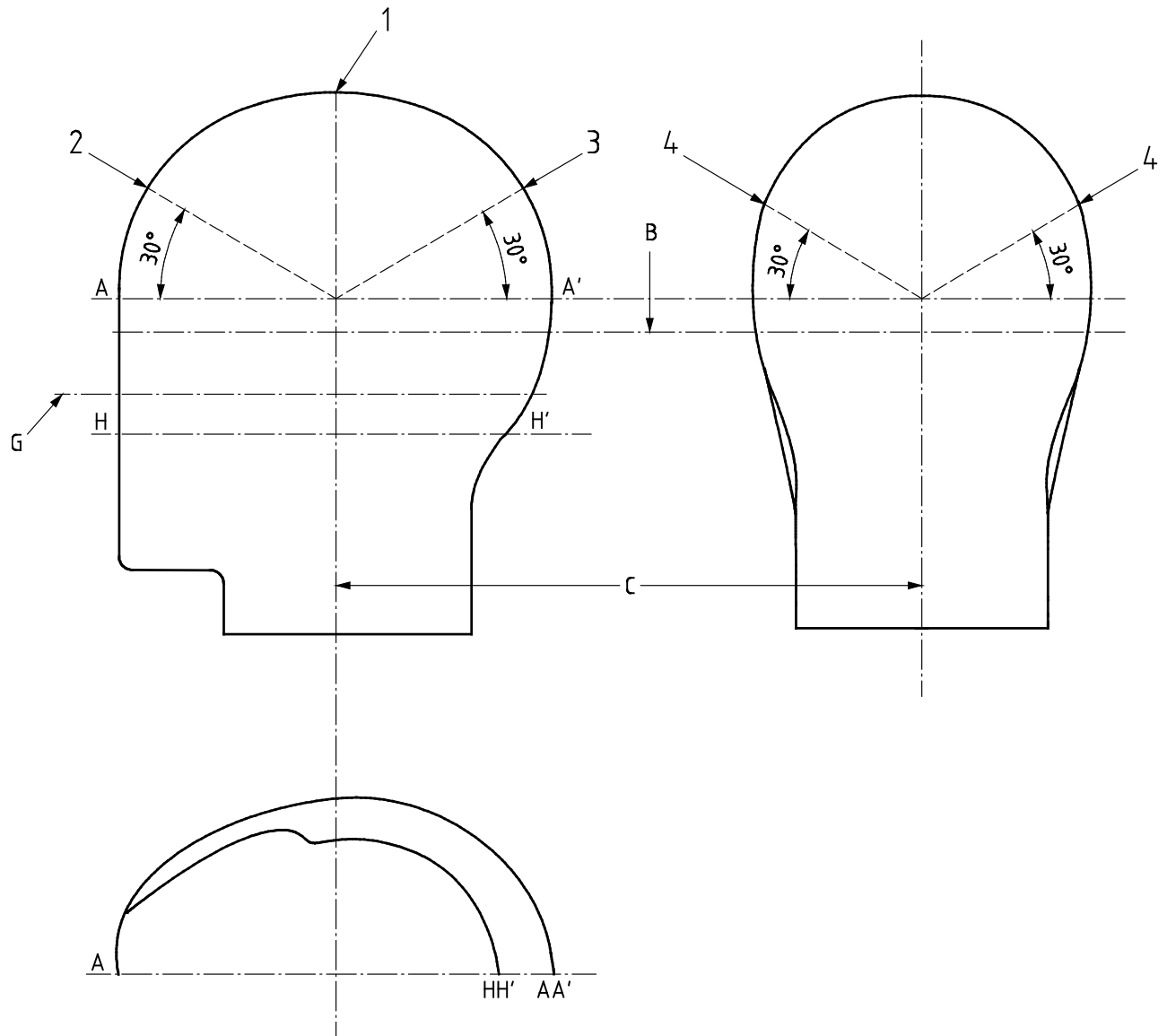

Key

- | | |
|----------|-----------------------|
| 1 to 4 | impact points |
| B | reference plane |
| C | central vertical axis |
| G | basic plane |
| AA', HH' | See EN 960 |

Figure 1 — Impact points on helmet

Annex A
(normative)

Conditioning and testing schedule

Table A.1 — Conditioning and testing schedule

	Sequence	1	2	3	4	5				
Sample	Helmet/Headform combination^a	Cleaning and disinfection 6.3.2	UV aged 6.3.3	Thermal plus 6.3.4	Thermal minus 6.3.5	Wet 6.3.6	Test 1		Test 2	
1	Largest helmet and largest appropriate headform	X	X	X			6.5.2 Impact	Crown	6.5.3 Impacts	Lateral
2	Largest helmet and largest appropriate headform	X	X		X		6.5.2 Impact	Crown	6.5.3 Impacts	Lateral
3	Largest helmet and largest appropriate headform	X	X			X	6.5.2 Impact	Crown	6.5.3 Impacts	Lateral
4	Smallest helmet fitting test block	X	X	X			6.6 Penetration resistance		N/A	
5	Smallest helmet fitting test block	X	X		X		6.6 Penetration resistance		N/A	
6	Largest helmet and smallest appropriate headform	X	X				6.13 Field of Vision		6.7 Retention system effectiveness	
7	Any helmet and appropriate largest headform	X	X				6.4 Extent of Protection		6.8 Retention system strength	
8	Any helmet and appropriate headform	X	X	X			6.9 Flame resistance		N/A	
9	Largest helmet and largest appropriate headform	X	X				6.10 Radiant heat protection		6.5.2 Crown Impact	

	Sequence	1	2	3	4	5		
Sample	Helmet/Headform combination ^a	Cleaning and disinfection 6.3.2	UV aged 6.3.3	Thermal plus 6.3.4	Thermal minus 6.3.5	Wet 6.3.6	Test 1	Test 2
10	Any helmet and appropriate headform	X	X				6.11 Thermal resistance	N/A
11	Any helmet and appropriate headform	X	X				6.12 Resistance to hot solids	N/A
^a The combination of helmet size and associated headform that provides the most unfavourable test condition for the purposes of this European Standard.								

Annex ZA (informative)

Relationship between this European Standard and the Essential Requirements of EU Directive 89/686/EEC

This European Standard has been prepared under a mandate given to CEN by the European Commission to provide a means of conforming to Essential Requirements of the New Approach Directive EU Directive 89/686/EEC.

Once this European Standard is cited in the Official Journal of the European Union under that Directive and has been implemented as a national standard in at least one Member State, compliance with the clauses of this European Standard given in Table ZA.1 confers, within the limits of the scope of this European Standard, a presumption of conformity with the corresponding Essential Requirements of that Directive and associated EFTA regulations.

Table ZA.1 — Correspondence between this European Standard and EU Directive 89/686/EEC

Clause(s)/sub-clause(s) of this EN	Essential Requirements (ERs) of Directive 89/686/EEC	Qualifying remarks/Notes
5.11	1.1.1 Ergonomics	
5.11	1.1.2.1 Highest level of protection possible	
4.3, 5.5, 5.7, 5.9, 5.11	1.2.1 Absence of risks and other 'inherent' nuisance factors	
4.1	1.2.1.1 Suitable constituent materials	
4.2	1.2.1.2 Satisfactory surface condition	
5.1, 5.10, 5.11	1.2.1.3 Maximum permissible user impediment	
4.3, 5.11.2 a), 5.11.2 b)	1.3.1 Adaptation of PPE to user morphology	
6.3	1.3.2 Lightness and design strength	
4.4	1.3.3 Compatibility of different PPE designed for simultaneous use	
4.1, 7, 8	1.4 Information supplied by manufacturer	
5.6	2.1 PPE incorporating adjustment systems	
7	2.4 PPE subject to ageing	
5.6	2.5 PPE which may be caught up during use	
5.11.2 d)	2.7 PPE intended for emergency use or rapid installation and/or removal	
8	2.8 PPE for use in very dangerous situations	

WARNING — Other requirements and other EU Directives may be applicable to the product(s) falling within the scope of this European Standard.

British Standards Institution (BSI)

BSI is the national body responsible for preparing British Standards and other standards-related publications, information and services.

BSI is incorporated by Royal Charter. British Standards and other standardization products are published by BSI Standards Limited.

About us

We bring together business, industry, government, consumers, innovators and others to shape their combined experience and expertise into standards-based solutions.

The knowledge embodied in our standards has been carefully assembled in a dependable format and refined through our open consultation process. Organizations of all sizes and across all sectors choose standards to help them achieve their goals.

Information on standards

We can provide you with the knowledge that your organization needs to succeed. Find out more about British Standards by visiting our website at bsigroup.com/standards or contacting our Customer Services team or Knowledge Centre.

Buying standards

You can buy and download PDF versions of BSI publications, including British and adopted European and international standards, through our website at bsigroup.com/shop, where hard copies can also be purchased.

If you need international and foreign standards from other Standards Development Organizations, hard copies can be ordered from our Customer Services team.

Subscriptions

Our range of subscription services are designed to make using standards easier for you. For further information on our subscription products go to bsigroup.com/subscriptions.

With **British Standards Online (BSOL)** you'll have instant access to over 55,000 British and adopted European and international standards from your desktop. It's available 24/7 and is refreshed daily so you'll always be up to date.

You can keep in touch with standards developments and receive substantial discounts on the purchase price of standards, both in single copy and subscription format, by becoming a **BSI Subscribing Member**.

PLUS is an updating service exclusive to BSI Subscribing Members. You will automatically receive the latest hard copy of your standards when they're revised or replaced.

To find out more about becoming a BSI Subscribing Member and the benefits of membership, please visit bsigroup.com/shop.

With a **Multi-User Network Licence (MUNL)** you are able to host standards publications on your intranet. Licences can cover as few or as many users as you wish. With updates supplied as soon as they're available, you can be sure your documentation is current. For further information, email bsmusales@bsigroup.com.

BSI Group Headquarters

389 Chiswick High Road London W4 4AL UK

Revisions

Our British Standards and other publications are updated by amendment or revision.

We continually improve the quality of our products and services to benefit your business. If you find an inaccuracy or ambiguity within a British Standard or other BSI publication please inform the Knowledge Centre.

Copyright

All the data, software and documentation set out in all British Standards and other BSI publications are the property of and copyrighted by BSI, or some person or entity that owns copyright in the information used (such as the international standardization bodies) and has formally licensed such information to BSI for commercial publication and use. Except as permitted under the Copyright, Designs and Patents Act 1988 no extract may be reproduced, stored in a retrieval system or transmitted in any form or by any means – electronic, photocopying, recording or otherwise – without prior written permission from BSI. Details and advice can be obtained from the Copyright & Licensing Department.

Useful Contacts:

Customer Services

Tel: +44 845 086 9001

Email (orders): orders@bsigroup.com

Email (enquiries): cservices@bsigroup.com

Subscriptions

Tel: +44 845 086 9001

Email: subscriptions@bsigroup.com

Knowledge Centre

Tel: +44 20 8996 7004

Email: knowledgecentre@bsigroup.com

Copyright & Licensing

Tel: +44 20 8996 7070

Email: copyright@bsigroup.com



...making excellence a habit.™