

BS EN 16287-1:2014



BSI Standards Publication

Glass packaging — Screw finishes for pressure capsules

Part 1: Returnable glass MCA 1 finish

bsi.

...making excellence a habit.™

National foreword

This British Standard is the UK implementation of EN 16287-1:2014.

The UK participation in its preparation was entrusted to Technical Committee PKW/0/-/7, Packaging - Glass.

A list of organizations represented on this committee can be obtained on request to its secretary.

This publication does not purport to include all the necessary provisions of a contract. Users are responsible for its correct application.

© The British Standards Institution 2014.
Published by BSI Standards Limited 2014

ISBN 978 0 580 82974 1
ICS 55.100

Compliance with a British Standard cannot confer immunity from legal obligations.

This British Standard was published under the authority of the Standards Policy and Strategy Committee on 31 May 2014.

Amendments issued since publication

Date	Text affected
------	---------------

ICS 55.100

English Version

**Glass packaging - Screw finishes for pressure capsules - Part 1:
Returnable glass MCA 1 finish**Emballage en verre - Bagues à vis pour capsules à
pression - Partie 1: Bague MCA 1 pour verre consignéVerpackungen aus Glas - Schraubmundstücke für Flaschen
mit Innendruck - Teil 1: Mehrweg-MCA 1-(Glas-)Mundstück

This European Standard was approved by CEN on 12 January 2014.

CEN members are bound to comply with the CEN/CENELEC Internal Regulations which stipulate the conditions for giving this European Standard the status of a national standard without any alteration. Up-to-date lists and bibliographical references concerning such national standards may be obtained on application to the CEN-CENELEC Management Centre or to any CEN member.

This European Standard exists in three official versions (English, French, German). A version in any other language made by translation under the responsibility of a CEN member into its own language and notified to the CEN-CENELEC Management Centre has the same status as the official versions.

CEN members are the national standards bodies of Austria, Belgium, Bulgaria, Croatia, Cyprus, Czech Republic, Denmark, Estonia, Finland, Former Yugoslav Republic of Macedonia, France, Germany, Greece, Hungary, Iceland, Ireland, Italy, Latvia, Lithuania, Luxembourg, Malta, Netherlands, Norway, Poland, Portugal, Romania, Slovakia, Slovenia, Spain, Sweden, Switzerland, Turkey and United Kingdom.

EUROPEAN COMMITTEE FOR STANDARDIZATION
COMITÉ EUROPÉEN DE NORMALISATION
EUROPÄISCHES KOMITEE FÜR NORMUNG**CEN-CENELEC Management Centre: Avenue Marnix 17, B-1000 Brussels**

Contents

	Page
Foreword.....	3
Introduction	4
1 Scope	4
2 Terms and definitions	4
3 Dimensions	4
Bibliography	9

Foreword

This document (EN 16287-1:2014) has been prepared by Technical Committee CEN/TC 261 "Packaging", the secretariat of which is held by AFNOR.

This European Standard shall be given the status of a national standard, either by publication of an identical text or by endorsement, at the latest by September 2014 and conflicting national standards shall be withdrawn at the latest by September 2014.

Attention is drawn to the possibility that some of the elements of this document may be the subject of patent rights. CEN [and/or CENELEC] shall not be held responsible for identifying any or all such patent rights.

EN 16287, *Glass packaging — Screw finishes for pressure capsules*, consists of the following parts:

- *Part 1: Returnable glass MCA 1 finish*
- *Part 2: One way glass MCA 1 finish*

According to the CEN-CENELEC Internal Regulations, the national standards organizations of the following countries are bound to implement this European Standard: Austria, Belgium, Bulgaria, Croatia, Cyprus, Czech Republic, Denmark, Estonia, Finland, Former Yugoslav Republic of Macedonia, France, Germany, Greece, Hungary, Iceland, Ireland, Italy, Latvia, Lithuania, Luxembourg, Malta, Netherlands, Norway, Poland, Portugal, Romania, Slovakia, Slovenia, Spain, Sweden, Switzerland, Turkey and the United Kingdom.

Introduction

This European Standard is based on CE.T.I.E. (International Technical Centre for Bottling and related Packaging) data sheet GME 32.05.[1]

Efficient packaging is of great importance for the distribution and the protection of goods. Insufficient or inappropriate packaging can lead to damage or wastage of the contents of the pack.

1 Scope

This European Standard specifies the dimensions of the 28 mm screw finish for glass containers designated MCA 1 for returnable glass.

2 Terms and definitions

For the purposes of this document, the following term and definition applies.

2.1
MCA
 (glass) finish designed for the closure of pressurized or vacuum liquids with a tamper-evident closure (metal or plastic)

3 Dimensions

The design and dimensions of the finish shall be as shown in Table 1 and Figure 1, Figure 2, Figure 3, Figure 4 and Figure 5.

Table 1 — Design and dimensions of the finish

Pitch	β	TPI	\varnothing cutter
3,175 mm	2° 12'	8	12,5 mm
β = Helix angle or angle of fixture to cutter. NOTE TPI = Threads per Inch. One inch is equal to 25,4 mm.			

The Tan β of helix angle for cutter is calculated via the following formula:

$$\tan \beta = \frac{\text{pitch}}{\frac{\pi(\text{nominal } T + \text{nominal } E)}{2}}$$

where

T is the thread diameter;

E is the wall diameter of threaded finish.

The average of the maximum and minimum of « L » diameter is as close as possible to « L » nominal.

The mean diameter $L \frac{\text{diameter max} + \text{diameter min}}{2}$ is in the tolerance of $\pm 0,2$ mm.

Optional: depressed thread at mould parting line (see EN 16292).

Dimensions in millimetres

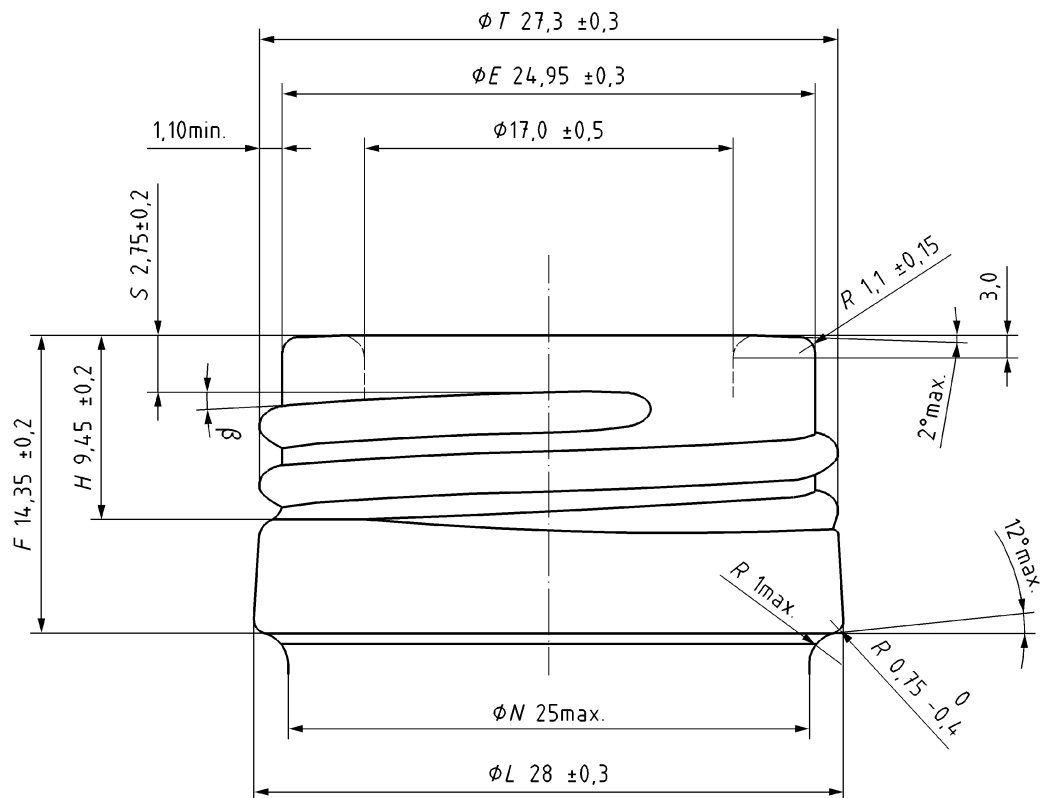

Key

- N* Neck (under bead) diameter
- H* Thread height
- S* Start of thread position from sealing surface to intersection of thread flank
- F* Height of the finish
- L* Locking bead diameter
- T* Thread diameter
- E* Wall diameter of threaded finish

NOTE Bore diameter ($17,0 \pm 0,5$) mm for a depth of 3 mm

Figure 1 — MCA 1 finish

Dimensions in millimetres

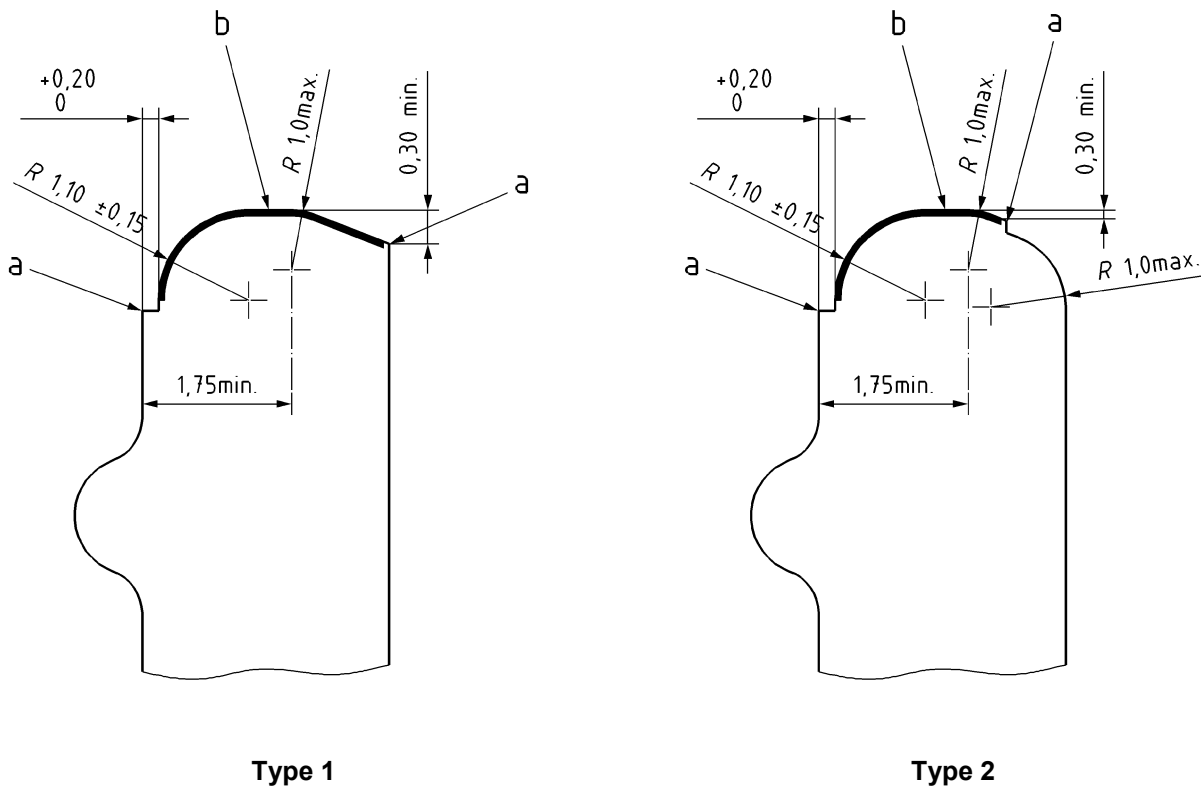

- Key**
- a Mould parting line
 - b Sealing surface

Figure 2 — Possible alternative constructions of the bore entrance to suit glass manufacturer

The sealing surface is smooth and free of any defects and flash.

Dimensions in millimetres
Minimum through bore $\varnothing 16,0$

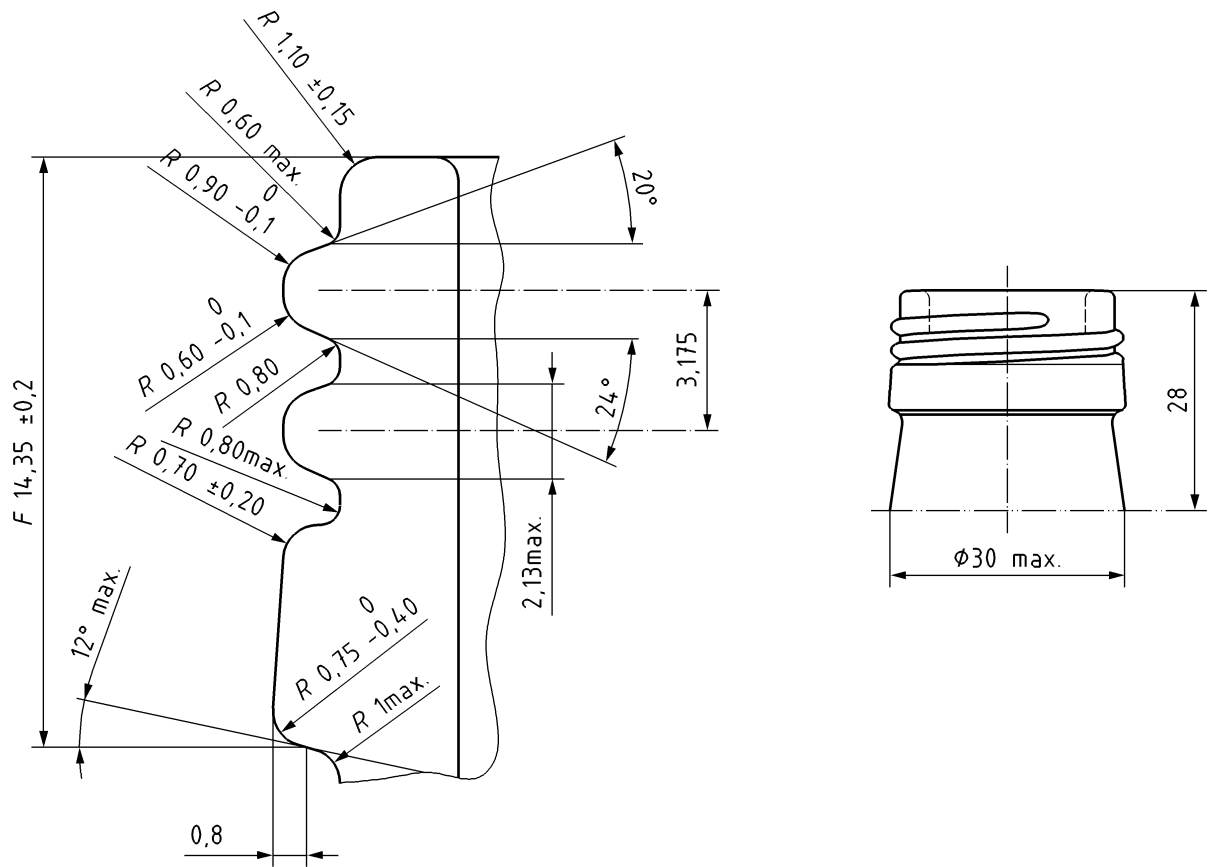
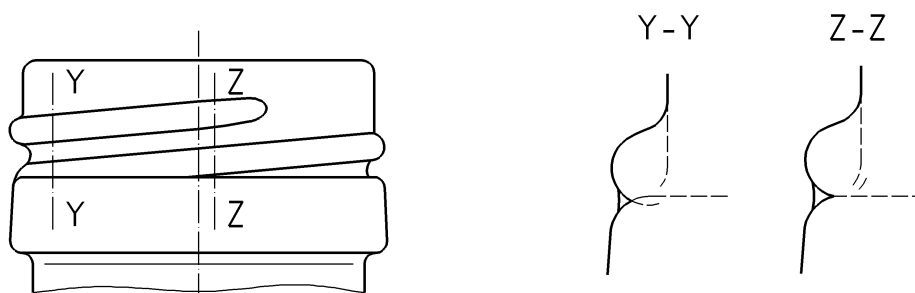

Figure 3 — Detail of the profile



NOTE Z-Z is the last full depth and width of thread. Beyond this point and Y-Y, the thread root is gradually increased to full thread diameter T in 90° .

Figure 4 — Run out of thread

Dimensions in millimetres

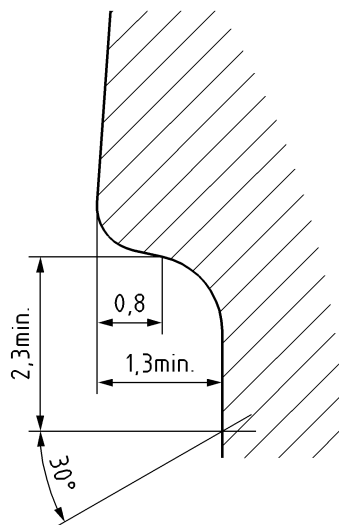

Figure 5 — Limit of construction

Bibliography

- [1] CE. T.I.E. data sheet GME 32.05 - *MCA 1 finish* ¹⁾
- [2] EN 16292, *Glass packaging - Screw finishes - Depressed threads*

¹⁾ Obtainable through *Centre Technique International de l'Embouteillage et du conditionnement* (CE.T.I.E), 112- 114, rue La Boétie, 7500Paris, France www.cetie.org, TP: 0033-1-42 65 26 45, TF: 0033-1-40 07 03 21.

British Standards Institution (BSI)

BSI is the national body responsible for preparing British Standards and other standards-related publications, information and services.

BSI is incorporated by Royal Charter. British Standards and other standardization products are published by BSI Standards Limited.

About us

We bring together business, industry, government, consumers, innovators and others to shape their combined experience and expertise into standards-based solutions.

The knowledge embodied in our standards has been carefully assembled in a dependable format and refined through our open consultation process. Organizations of all sizes and across all sectors choose standards to help them achieve their goals.

Information on standards

We can provide you with the knowledge that your organization needs to succeed. Find out more about British Standards by visiting our website at bsigroup.com/standards or contacting our Customer Services team or Knowledge Centre.

Buying standards

You can buy and download PDF versions of BSI publications, including British and adopted European and international standards, through our website at bsigroup.com/shop, where hard copies can also be purchased.

If you need international and foreign standards from other Standards Development Organizations, hard copies can be ordered from our Customer Services team.

Subscriptions

Our range of subscription services are designed to make using standards easier for you. For further information on our subscription products go to bsigroup.com/subscriptions.

With **British Standards Online (BSOL)** you'll have instant access to over 55,000 British and adopted European and international standards from your desktop. It's available 24/7 and is refreshed daily so you'll always be up to date.

You can keep in touch with standards developments and receive substantial discounts on the purchase price of standards, both in single copy and subscription format, by becoming a **BSI Subscribing Member**.

PLUS is an updating service exclusive to BSI Subscribing Members. You will automatically receive the latest hard copy of your standards when they're revised or replaced.

To find out more about becoming a BSI Subscribing Member and the benefits of membership, please visit bsigroup.com/shop.

With a **Multi-User Network Licence (MUNL)** you are able to host standards publications on your intranet. Licences can cover as few or as many users as you wish. With updates supplied as soon as they're available, you can be sure your documentation is current. For further information, email bsmusales@bsigroup.com.

BSI Group Headquarters

389 Chiswick High Road London W4 4AL UK

Revisions

Our British Standards and other publications are updated by amendment or revision.

We continually improve the quality of our products and services to benefit your business. If you find an inaccuracy or ambiguity within a British Standard or other BSI publication please inform the Knowledge Centre.

Copyright

All the data, software and documentation set out in all British Standards and other BSI publications are the property of and copyrighted by BSI, or some person or entity that owns copyright in the information used (such as the international standardization bodies) and has formally licensed such information to BSI for commercial publication and use. Except as permitted under the Copyright, Designs and Patents Act 1988 no extract may be reproduced, stored in a retrieval system or transmitted in any form or by any means – electronic, photocopying, recording or otherwise – without prior written permission from BSI. Details and advice can be obtained from the Copyright & Licensing Department.

Useful Contacts:

Customer Services

Tel: +44 845 086 9001

Email (orders): orders@bsigroup.com

Email (enquiries): cservices@bsigroup.com

Subscriptions

Tel: +44 845 086 9001

Email: subscriptions@bsigroup.com

Knowledge Centre

Tel: +44 20 8996 7004

Email: knowledgecentre@bsigroup.com

Copyright & Licensing

Tel: +44 20 8996 7070

Email: copyright@bsigroup.com



...making excellence a habit.™