

BS EN 16191:2014



BSI Standards Publication

Tunnelling machinery — Safety requirements

bsi.

...making excellence a habit.™

National foreword

This British Standard is the UK implementation of EN 16191:2014. It supersedes BS EN 12336:2005+A1:2008 and BS EN 815:1996+A2:2008 which are withdrawn.

The UK participation in its preparation was entrusted to Technical Committee B/513, Construction equipment and plant and site safety.

A list of organizations represented on this committee can be obtained on request to its secretary.

This publication does not purport to include all the necessary provisions of a contract. Users are responsible for its correct application.

© The British Standards Institution 2014.
Published by BSI Standards Limited 2014

ISBN 978 0 580 73023 8
ICS 91.220; 93.060

Compliance with a British Standard cannot confer immunity from legal obligations.

This British Standard was published under the authority of the Standards Policy and Strategy Committee on 31 May 2014.

Amendments/corrigenda issued since publication

Date	Text affected
------	---------------

English Version

Tunnelling machinery - Safety requirements

Tunneliers - Prescriptions de sécurité

Tunnelbaumaschinen - Sicherheitstechnische
Anforderungen

This European Standard was approved by CEN on 10 April 2014.

CEN members are bound to comply with the CEN/CENELEC Internal Regulations which stipulate the conditions for giving this European Standard the status of a national standard without any alteration. Up-to-date lists and bibliographical references concerning such national standards may be obtained on application to the CEN-CENELEC Management Centre or to any CEN member.

This European Standard exists in three official versions (English, French, German). A version in any other language made by translation under the responsibility of a CEN member into its own language and notified to the CEN-CENELEC Management Centre has the same status as the official versions.

CEN members are the national standards bodies of Austria, Belgium, Bulgaria, Croatia, Cyprus, Czech Republic, Denmark, Estonia, Finland, Former Yugoslav Republic of Macedonia, France, Germany, Greece, Hungary, Iceland, Ireland, Italy, Latvia, Lithuania, Luxembourg, Malta, Netherlands, Norway, Poland, Portugal, Romania, Slovakia, Slovenia, Spain, Sweden, Switzerland, Turkey and United Kingdom.

EUROPEAN COMMITTEE FOR STANDARDIZATION
COMITÉ EUROPÉEN DE NORMALISATION
EUROPÄISCHES KOMITEE FÜR NORMUNG**CEN-CENELEC Management Centre: Avenue Marnix 17, B-1000 Brussels**

Contents

Page

Foreword.....	5
Introduction	6
1 Scope	7
2 Normative references	7
3 Terms and definitions	10
4 List of significant hazards	12
5 Safety requirements and/or protective measures	14
5.1 General.....	14
5.2 Specific requirements	14
5.2.1 Sharp corners and edges.....	14
5.2.2 Hot surfaces	14
5.2.3 Hydraulic hoses, installation and shielding.....	14
5.2.4 Cutter head	14
5.2.5 Handling of heavy loads	15
5.2.6 Rotation and displacement (axial movement)	16
5.2.7 Structural collapse of the shield	16
5.2.8 Air locks.....	16
5.2.9 Rock bolting devices	17
5.2.10 Access to and egress from operating positions and servicing points	17
5.2.11 Protection against falling objects, face collapse, rockfall and flood	18
5.2.12 Pipe jacking rigs	18
5.3 Control stations	19
5.3.1 General.....	19
5.3.2 Ergonomics	19
5.3.3 Visibility	19
5.4 Guards and protective devices	19
5.4.1 General.....	19
5.4.2 Design of guards.....	19
5.4.3 Belt conveyor	19
5.4.4 Access to excavation chamber, cutter head or other digging equipment.....	19
5.4.5 Auger extensions during jacking operations	20
5.5 Control systems.....	20
5.5.1 Safety and reliability of control systems.....	20
5.5.2 Control devices	21
5.5.3 Remote control.....	21
5.5.4 Starting and stopping.....	22
5.5.5 Warning system	22
5.5.6 Failure of power supply	23
5.6 Towing connection	24
5.7 Laser guidance.....	24
5.8 Ventilation and the control of dust and gas.....	24
5.8.1 General.....	24
5.8.2 Dust control.....	25
5.8.3 Ventilation.....	25
5.8.4 Atmospheric changes and ingress of gases	25
5.8.5 Internal combustion engines.....	26
5.9 Noise	26
5.9.1 General.....	26
5.9.2 Noise reduction at source at the design stage.....	26
5.9.3 Information on residual risk	27

5.10	Electrical equipment.....	27
5.10.1	General.....	27
5.10.2	Protective measures.....	27
5.10.3	Cables.....	28
5.10.4	Transformers.....	28
5.10.5	Bonding.....	28
5.10.6	Switch gear.....	28
5.10.7	Lighting.....	28
5.10.8	Emergency lighting.....	29
5.10.9	Electromagnetic compatibility (EMC).....	29
5.10.10	Isolation of high voltage power supply.....	29
5.11	Hydraulic and pneumatic systems.....	29
5.12	Fire prevention and protection.....	30
5.12.1	General.....	30
5.12.2	Fixed fire extinguishing systems.....	30
5.12.3	Installation of portable fire extinguishers.....	30
5.12.4	Water curtain on towed back-up equipment.....	30
5.13	Storage of rescue equipment.....	30
5.14	Refuge chamber.....	31
5.15	Probe drilling equipment.....	31
5.16	Transportation, lifting and assembly.....	31
5.16.1	Transportation.....	31
5.16.2	Lifting.....	31
5.16.3	Assembly.....	31
5.17	Maintenance.....	31
5.17.1	General.....	31
5.17.2	Work on cutter heads or shield-mounted cutter booms and excavators.....	31
5.17.3	Work on micro tunnelling machines.....	32
6	Verification of the safety requirements and/or protective measures.....	32
7	Information for use.....	32
7.1	General.....	32
7.2	Emergency information, warning signs and symbols.....	32
7.2.1	Warning signs.....	32
7.2.2	Warning devices.....	32
7.2.3	Symbols.....	32
7.2.4	Emergency information.....	32
7.3	Instruction handbook.....	33
7.3.1	General.....	33
7.3.2	Operating instructions.....	34
7.3.3	Maintenance.....	35
7.4	Marking.....	35
Annex A (informative)	Examples of tunnelling machines.....	37
Annex B (normative)	Verification of safety requirements and/or protective measures.....	41
Annex C (normative)	Noise test code.....	45
C.1	Scope.....	45
C.2	A-weighted emission sound pressure levels at working areas.....	45
C.3	Installation and operating conditions.....	46
C.4	Information to be recorded and reported.....	46
C.5	Declaration noise emission values.....	46
Annex D (normative)	Minimum requirements for refuge chamber.....	47
D.1	General.....	47
D.2	Concept and design.....	47

D.3	Air supply	47
D.4	Visual identification	48
D.5	Power supply.....	48
D.6	Interior equipment	48
D.7	Instruction manual.....	48
Annex ZA (informative) Relationship between this European Standard and the Essential Requirements of EU Directive 2006/42/EC		49
Bibliography.....		50

Foreword

This document (EN 16191:2014) has been prepared by Technical Committee CEN/TC 151 “Construction equipment and building material machines - Safety”, the secretariat of which is held by DIN.

This European Standard shall be given the status of a national standard, either by publication of an identical text or by endorsement, at the latest by November 2014 and conflicting national standards shall be withdrawn at the latest by November 2014.

Attention is drawn to the possibility that some of the elements of this document may be the subject of patent rights. CEN [and/or CENELEC] shall not be held responsible for identifying any or all such patent rights.

This document supersedes EN 12336:2005+A1:2008 and EN 815:1996+A2:2008.

The main technical changes compared to EN 12336:2005+A1:2008 and EN 815:1996+A2:2008 are the following:

- update of the scope;
- update of normative references;
- improvement of requirements on access systems, especially on minimum dimensions on walkways and access openings;
- requirements on control systems improved;
- improvement of fire prevention and protection;
- improvement of noise test code.

This document has been prepared under a mandate given to CEN by the European Commission and the European Free Trade Association, and supports essential requirements of EU Directive(s).

For relationship with EU Directive(s), see informative Annex ZA, which is an integral part of this document.

According to the CEN-CENELEC Internal Regulations, the national standards organizations of the following countries are bound to implement this European Standard: Austria, Belgium, Bulgaria, Croatia, Cyprus, Czech Republic, Denmark, Estonia, Finland, Former Yugoslav Republic of Macedonia, France, Germany, Greece, Hungary, Iceland, Ireland, Italy, Latvia, Lithuania, Luxembourg, Malta, Netherlands, Norway, Poland, Portugal, Romania, Slovakia, Slovenia, Spain, Sweden, Switzerland, Turkey and the United Kingdom.

Introduction

This European Standard is a type C standard as stated in EN ISO 12100:2010.

The machinery concerned and the extent to which hazards, hazardous situations and events are covered are indicated in the scope of this document.

The intended use of the machinery is agreed between the manufacturer and the user taking into account information on predicted ground conditions provided by the user.

When provisions of this type C standard are different from those which are stated in type A or B standards, the provisions of this type C standard take precedence over the provisions of the other standards, for machines that have been designed and built according to the provisions of this type C standard.

1 Scope

This European Standard is applicable to tunnelling machinery as defined in Clause 3 used for the construction of tunnels, shafts and other underground excavations.

It deals with all significant hazards, hazardous situations and events relevant to such machinery when they are used as intended and under the conditions of misuse which are reasonably foreseeable by the manufacturer (see Clause 4).

This European Standard covers monitoring for hazardous atmospheres within the confines of the tunnelling machinery.

Hand-arm and whole-body vibration are not considered as significant hazard for tunnelling machinery.

The following items and applications are not covered by this European Standard:

- the additional requirements for the use of tunnelling machinery under hyperbaric conditions;
- the additional requirements for use of tunnelling machinery in potentially explosive atmospheres;

NOTE For the application in potentially explosive atmospheres see EN 1710:2005+A1:2008 for guidance.

- ancillary tools and equipment which are not an integral part of the tunnelling machinery but used on or with the machinery;
- services (e.g. power supply, water, pipes, compressed air, etc.) supplied to the tunnelling machinery;
- loading and transport equipment which is not an integral part of the tunnelling machinery, e.g. man riders, locomotives, grout cars, segment cars, muck cars and shaft hoisting equipment.

This European Standard is not applicable to road headers, continuous miners and impact rippers.

This European Standard is not applicable to tunnelling machinery which is manufactured before the date of publication of this European Standard by CEN.

2 Normative references

The following documents, in whole or in part, are normatively referenced in this document and are indispensable for its application. For dated references, only the edition cited applies. For undated references, the latest edition of the referenced document (including any amendments) applies.

EN 3-7:2004+A1:2007, *Portable fire extinguishers - Part 7: Characteristics, performance requirements and test methods*

EN 363:2008, *Personal fall protection equipment - Personal fall protection systems*

EN 620:2002+A1:2010, *Continuous handling equipment and systems - Safety and EMC requirements for fixed belt conveyors for bulk materials*

EN 894-3:2000+A1:2008, *Safety of machinery - Ergonomics requirements for the design of displays and control actuators - Part 3: Control actuators*

EN 953:1997+A1:2009, *Safety of machinery - Guards - General requirements for the design and construction of fixed and movable guards*

EN 981:1996+A1:2008, *Safety of machinery - System of auditory and visual danger and information signals*

EN 1837:1999+A1:2009, *Safety of machinery - Integral lighting of machines*

EN 1993-1-1:2005, *Eurocode 3: Design of steel structures — Part 1-1: General rules and rules for buildings*

- EN 12110:2014, *Tunnelling machines — Air locks — Safety requirements*
- EN 13309:2010, *Construction machinery - Electromagnetic compatibility of machines with internal power supply*
- EN 13478:2001+A1:2008, *Safety of machinery - Fire prevention and protection*
- EN 14973:2006+A1:2008, *Conveyor belts for use in underground installations - Electrical and flammability safety requirements*
- EN 16228-1:2014, *Drilling and foundation equipment — Safety — Part 1: Common requirements*
- EN 16228-2:2014, *Drilling and foundation equipment — Safety — Part 2: Mobile drill rigs for civil and geotechnical engineering, quarrying and mining*
- EN 60076-2:2011, *Power transformers — Part 2: Temperature rise for liquid-immersed transformers (IEC 60076-2:2011)*
- EN 60079-0:2012, *Explosive atmospheres — Part 0: Equipment — General requirements (IEC 60079-0:2011, modified)*
- EN 60204-1:2006, *Safety of machinery — Electrical equipment of machines — Part 1: General requirements (IEC 60204-1:2005, modified)*
- EN 60204-11:2000, *Safety of machinery — Electrical equipment of machines — Part 11: Requirements for HV equipment for voltages above 1000 V a.c. or 1500 V d.c. and not exceeding 36 kV (IEC 60204-11:2000)*
- EN 60439-2:2000, *Low-voltages switchgear and controlgear assemblies — Part 2: Particular requirements for busbar trunking systems (busways) (IEC 60439-2:2000)*
- EN 60439-3:1991, *Low-voltage switchgear and controlgear assemblies – Part 3: Particular requirements for low-voltage switchgear and controlgear assemblies intended to be installed in places where unskilled persons have access for their use - Distribution boards (IEC 60439-3:1990, modified)*
- EN 60439-4:2004, *Low-voltage switchgear and controlgear assemblies — Part 4: Particular requirements for assemblies for construction sites (ACS) (IEC 60439-4:2004)*
- EN 60529:1991, *Degrees of protection provided by enclosures (IP code) (IEC 60529:1989)*
- EN 60825-1:2007, *Safety of laser products — Part 1: Equipment classification and requirements (IEC 60825-1:2007)*
- EN 60947-1:2007, *Low-voltage switchgear and controlgear — Part 1: General rules (IEC 60947-1:2007)*
- EN 61008-1:2012, *Residual current operated circuit-breakers without integral overcurrent protection for household and similar uses (RCCB's) — Part 1: General rules (IEC 61008-1:2010, modified)*
- EN 61310-1:2008, *Safety of machinery — Indication, marking and actuation — Part 1: Requirements for visual, acoustic and tactile signals (IEC 61310-1:2007)*
- EN 61439-1:2011, *Low-voltage switchgear and controlgear assemblies — Part 1: General rules (IEC 61439-1:2011)*
- EN ISO 3411:2007, *Earth-moving machinery - Physical dimensions of operators and minimum operator space envelope (ISO 3411:2007)*
- EN ISO 3449:2008, *Earth-moving machinery - Falling-object protective structures - Laboratory tests and performance requirements (ISO 3449:2005)*
- EN ISO 3457:2008, *Earth-moving machinery - Guards - Definitions and requirements (ISO 3457:2003)*

- EN ISO 4413:2010, *Hydraulic fluid power - General rules and safety requirements for systems and their components (ISO 4413:2010)*
- EN ISO 4414:2010, *Pneumatic fluid power - General rules and safety requirements for systems and their components (ISO 4414:2010)*
- EN ISO 4871:2009, *Acoustics - Declaration and verification of noise emission values of machinery and equipment (ISO 4871:1996)*
- EN ISO 7096:2008, *Earth-moving machinery - Laboratory evaluation of operator seat vibration (ISO 7096:2000)*
- EN ISO 11202:2010, *Acoustics - Noise emitted by machinery and equipment - Determination of emission sound pressure levels at a work station and at other specified positions applying approximate environmental corrections (ISO 11202:2010)*
- EN ISO 11688-1:2009, *Acoustics - Recommended practice for the design of low-noise machinery and equipment - Part 1: Planning (ISO/TR 11688-1:1995)*
- EN ISO 12100:2010, *Safety of machinery - General principles for design - Risk assessment and risk reduction (ISO 12100:2010)*
- EN ISO 12922:2012, *Lubricants, industrial oils and related products (class L) - Family H (Hydraulic systems) - Specifications for hydraulic fluids in categories HFAE, HFAS, HFB, HFC, HFDR and HFDU (ISO 12922:2012)*
- EN ISO 13732-1:2008, *Ergonomics of the thermal environment - Methods for the assessment of human responses to contact with surfaces - Part 1: Hot surfaces (ISO 13732-1:2006)*
- EN ISO 13849-1:2008, *Safety of machinery - Safety-related parts of control systems - Part 1: General principles for design (ISO 13849-1:2006)*
- EN ISO 13850:2008, *Safety of machinery - Emergency stop - Principles for design (ISO 13850:2006)*
- EN ISO 14122-1:2001, *Safety of machinery - Permanent means of access to machinery - Part 1: Choice of fixed means of access between two levels (ISO 14122-1:2001)*
- EN ISO 14122-2:2001, *Safety of machinery - Permanent means of access to machinery - Part 2: Working platforms and walkways (ISO 14122-2:2001)*
- EN ISO 14122-3:2001, *Safety of machinery - Permanent means of access to machinery - Part 3: Stairs, stepladders and guard-rails (ISO 14122-3:2001)*
- EN ISO 14122-4:2004, *Safety of machinery — Permanent means of access to machinery — Part 4: Fixed ladders (ISO 14122-4:2004)*
- ISO 3795:1989, *Road vehicles, and tractors and machinery for agriculture and forestry — Determination of burning behaviour of interior materials*
- ISO 3864-1:2011, *Graphical symbols — Safety colours and safety signs — Part 1: Design principles for safety signs and safety markings*
- ISO 6405-1:2004, *Earth-moving machinery — Symbols for operator controls and other displays — Part 1: Common symbols*
- ISO 11112:1995, *Earth-moving machinery — Operator's seat — Dimensions and requirements*
- ISO 12508:1994, *Earth-moving machinery — Operator station and maintenance areas — Bluntness of edges*
- ISO 15817:2012, *Earth-moving machinery — Safety requirements for remote operator control systems*

3 Terms and definitions

For the purposes of this document, the terms and definitions given in EN ISO 12100:2010 and the following apply.

3.1

tunnelling machinery

machine used in the excavation and construction of tunnels and shafts, as described in 3.2 to 3.10

3.2

shield machine

steerable ground support structure within which tunnel excavation takes place by manual, mechanical or hydraulic means. Erection of tunnel support may take place within the shield machine

Note 1 to entry: The shield machine is propelled forward by reaction onto the tunnel lining. See Figure A.1. Shield machines provide lateral and/or radial ground support. In addition they can provide various types of face support and ground water control.

3.3

shielded tunnel boring machine

shield machine for full face excavation, having one or more rotating cutter heads in which the cutter head(s) may be separated from the rest of the shield by a shield bulkhead. Passage of material through the shield bulkhead may be controlled

Note 1 to entry: Reaction forces caused by the excavation process are transferred into the tunnel lining. See Figure A.2.

3.4

telescopic shield machine

shielded tunnel boring machine as defined in 3.3 equipped with a gripping system as described in 3.12

Note 1 to entry: Telescopic shield machine is also known as a double shield machine.

3.5

unshielded tunnel boring machine

machine for mechanical excavation using a rotating cutter head. The machine has no shield for ground support but can have a shield for the protection of the cutter head. See Figure A.3

Note 1 to entry: The torque and thrust reactions are resisted by anchoring the complete machinery against the ground by means of a gripping system.

3.6

reaming machine

unshielded tunnel boring machine used to enlarge a pilot tunnel in one or more steps

Note 1 to entry: In most cases unshielded tunnel boring machinery work the full face of the tunnel. However, in some cases the tunnel is driven in two or more phases, by starting with a pilot hole which is enlarged in one or more steps. This method is called reaming. The machines used are in principle the same as an unshielded tunnel boring machine driving the whole tunnel area in one step.

3.7

shaft boring machine

tunnelling machine as defined in 3.2 to 3.6 designed to operate in the vertical or near vertical direction

3.8

micro tunnelling machine

shielded tunnel boring machine designed for non-man entry operation (except for maintenance purposes when out of service) which is remotely controlled by an operator from outside the tunnel. See Figure A.4

3.9

thrust boring machine

machine for constructing pipelines by displacement

3.10

auger boring machine

non-steerable machine for constructing pipelines using continuous flight augers for excavation and spoil removal

3.11

partial face excavation equipment

cutter boom or backhoe excavator installed in a shield machine, see Figure A.1

3.12

gripping system

equipment for the transfer of the reactive forces caused by the excavation process into the tunnel wall

3.13

regripping

process of disengaging the gripping system, relocating and re-engaging the gripping system

3.14

excavation chamber

front part of a shield between ground face and shield bulkhead, into which the ground is excavated

3.15

back-up equipment

steel construction which accommodates equipment, to provide the machine with services for its operation and its crew with facilities for their work and comfort

Note 1 to entry: For tunnelling machinery described in 3.2 to 3.7 the back-up equipment is normally towed behind the machine i.e. it is "towed back-up equipment" whereas for pipe jacking and micro tunnelling equipment, thrust boring and auger boring machines, the back-up equipment is installed at the bottom of an access shaft or on the surface adjacent thereto.

3.16

pipe jacking rig

hydraulic jacking equipment, used to drive a pipe string through the ground to form a tunnel lining

3.17

lining erection equipment (Erector)

handling and erecting equipment for tunnel lining segments, situated within or immediately behind a shield machine

3.18

erecting device

equipment for handling and erection of other ground support elements such as steel ribs, situated within a tunnel boring machine and its back-up equipment

3.19

rockbolting device

equipment for drilling and installation of rock bolts, situated within or behind an unshielded tunnel boring machine

3.20

probe drilling equipment

drilling equipment for ground investigation ahead of and around the tunnel

3.21

control station

any location on a tunnelling machinery or back-up equipment from where one or more functions of the tunnelling machinery, back-up equipment or their separate working units can be controlled by an operator

3.22

main control station

control station from where the excavation operation and the advance of the tunnelling machinery is controlled

- 3.23**
walkway
part of the access system that permits walking or moving between locations on a tunnelling machinery
- 3.24**
access opening
opening within tunnelling machinery through which a man may pass to access servicing points, for example (e.g.) in the shield bulkhead or the cutterhead
- 3.25**
servicing point
any location on a tunnelling machinery or back-up equipment where maintenance or servicing is carried out
- 3.26**
working area
area on or in tunnelling machinery, where work is performed, for example (e.g.) rock bolt installation, ring beam erection, segment handling and ring erection, services extension
- 3.27**
trailing cable
power cable which extends from the towed back-up equipment to the tunnel power supply normally stowed on the cable drum or cable trail
- 3.28**
essential services
service which is maintained in the event of a loss of the main power supply
- 3.29**
refuge chamber
enclosed space which provides life support for persons trapped in tunnel by smoke, fume or gas
- 3.30**
air lock
self-contained pressure vessel with one or more compartments that permits passage between areas of different pressure
- [SOURCE: EN 12110:2014, 3.3]
- 3.31**
shield bulkhead
structure which separates the excavation chamber from the tunnel
- 3.32**
internal diameter
internal diameter of the lining through which the backup equipment is being towed. For unshielded machines, the internal diameter is that within the planned rock support

4 List of significant hazards

This clause contains all the significant hazards, hazardous situations and events, identified by risk assessment as significant for this type of machinery and which require action to eliminate or reduce the risk.

Noise is not a significant hazard for micro tunnelling, thrust boring and auger boring machines as they do not expose persons to noise.

Table 1 — List of significant hazards

	Hazards	Relevant clause/Subclause in this European Standard
4.1	Mechanical hazards	
a)	Crushing hazard	5.2.4, 5.2.7, 5.2.10, 5.2.12, 5.4.1, 5.4.4, 5.4.5, 5.5.1, 5.5.2, 5.5.4.3, 5.16.2, 5.17.2,
b)	Friction or abrasive hazard	5.2.1
c)	High pressure fluid injection hazard	5.2.3, 5.3.1, 5.11
d)	Loss of stability and structural collapse	5.2.6, 5.2.7, 5.2.9, 5.2.12, 5.16.2
e)	Slip, trip and fall hazards	5.2.5.2, 5.2.6, 5.2.10, 5.4.4, 5.6
4.2	Electrical hazards	
a)	Electrical contact, direct or indirect	5.10
b)	External influences on electrical equipment	5.5.3, 5.10.9
4.3	Thermal hazards	5.2.2
4.4	Hazards generated by noise	
a)	Hearing damage, tinnitus, physiological disorders, accidents due to interference with speech communication and perception of danger signals	5.3.1, 5.9
4.5	Hazards generated by radiation	
a)	Laser	5.7
4.6	Hazards generated by materials and substances	
a)	Materials processed, used or exhausted by machinery	5.8.2, 5.15
b)	Dust and gas	5.3.1, 5.5.5, 5.8
c)	Fire or explosion	5.2.3, 5.4.3, 5.5.5, 5.8.4, 5.10.3, 5.10.4, 5.12
d)	Falling objects, face collapse and flood	5.2.4, 5.2.11, 5.4.4, 5.5.5, 5.16.2
4.7	Hazards generated by neglect of ergonomics principles	
a)	Unhealthy posture or excessive efforts	5.2.5, 5.2.10, 5.3.2, 5.3.3, 5.13, 5.14
b)	Inadequate lighting	5.10.7, 5.10.8, 5.14
4.8	Hazards caused by failure of energy supply	
a)	Failure of energy supply	5.2.5.2, 5.2.6.2, 5.4.4, 5.5.1, 5.5.6, 5.11, 5.14
b)	Failure of control system	5.5, 5.11
4.9	Hazards caused by missing and/or incorrectly positioned safety related measures	
a)	All kinds of guards	5.2.10, 5.4, 5.15
b)	All kinds of safety related devices	5.4, 5.5, 5.6, 5.14
c)	Starting and stopping devices	5.2.6, 5.3.3, 5.5.2, 5.5.4,
d)	Safety signs and tags, all kinds of information of warning devices	5.2.4, 5.2.5, 5.2.6, 5.2.7, 5.2.11, 5.4, 5.4.1, 5.5.1, 5.5.5, 5.6, 5.7, 5.8, 5.11, 5.12, 5.16.2, 5.16.3, 7.2.1, 7.2.4, D.3
e)	Energy supply disconnecting devices	5.10.2, 5.10.6

	Hazards	Relevant clause/Subclause in this European Standard
f)	Emergency stop devices	5.5.1, 5.5.4.3
g)	Safe handling of machinery and parts, loading and unloading operations	5.2.5, 5.2.12, 5.16.1, 5.16.2, 5.16.3
h)	Essential equipment and accessories for safe adjustment and/or maintenance	5.16.1, 5.17, 5.16.3
i)	Equipment evacuating gases	5.8

5 Safety requirements and/or protective measures

5.1 General

Tunnelling machinery shall comply with the safety requirements and/or protective measures of this clause.

In addition, the tunnelling machinery shall be designed according to the principles of EN ISO 12100:2010 for hazards relevant but not significant which are not dealt with by this European Standard.

5.2 Specific requirements

5.2.1 Sharp corners and edges

Accessible parts of tunnelling machinery shall be designed and manufactured to minimize sharp edges, angles or rough surfaces which are likely to cause injury.

The design shall be in accordance with ISO 12508:1994.

5.2.2 Hot surfaces

Where there is a risk of contact with hot surfaces in accessible areas, suitable measures shall be taken:

- a) to limit the temperature of hot surfaces, for guidance see EN ISO 13732-1;
- b) where this is not possible, to prevent contact with those surfaces/parts by screens or guards;
- c) to provide warning signs against residual risks, see 7.2.1 and 7.3.2.

5.2.3 Hydraulic hoses, installation and shielding

Hydraulic hoses shall comply with the requirements of EN ISO 4413 and be protected from damage by moving parts.

Adequate shielding in accordance with Clause 9 of EN ISO 3457:2008 shall be provided to protect persons in working areas.

NOTE See for guidance, 30 CFR § 18.65 Flame test of hose, for hoses see website <http://www.msha.gov/techsupp/acc/lists/00hyhose.pdf>.

5.2.4 Cutter head

In order to carry out inspection and maintenance work, access shall be provided including access openings in accordance with 5.2.10.3 to the area behind or inside the cutter head and similarly through a cutter head to the area in front of it. Where possible and in any case for cutter heads of 4,5 m diameter or more the cutter head shall be so designed that replacement of cutters can be done without entering the area in front of the cutter head, e.g. back loaded cutters.

Where certain cutter locations, for example gauge and central part of the cutter head, may not be accessible from behind, alternative arrangements shall be made.

Special instructions shall be given in the instruction handbook.

The design shall allow for safe inspection and maintenance in the excavation chamber, e.g. backloading cutter head, mechanical protection (e.g. face support plates, slot gate closures).

NOTE In case of unstable ground conditions this can also be ensured by:

- ground improvement e.g. pre excavation grouting;
- compressed air for face support and/or groundwater control.

Technical solutions for reducing inspection and maintenance in the excavation chamber shall be preferred. When the cutter head has been stopped, any drift away from that position, for whatever reason other than action on the control devices, shall be prevented (see Table 3). The means of achieving this shall be capable of resisting 5 % of the maximum installed cutter head torque or a minimum eccentric load of 5 kN at the periphery of the cutter head whichever is the greater. Where other movements of the cutter head can occur due to gravity, the load to be resisted shall be 2 times the relevant load given, resulting from the maximum inclination as defined by the manufacturer.

The measures foreseen above, the ground conditions and the permissible inclination for which the machinery has been designed and warnings against residual risks shall be listed in the instruction handbook as required in 7.3.1.

5.2.5 Handling of heavy loads

5.2.5.1 Handling of consumables items and machine parts

Equipment shall be provided for handling consumable items which require regular replacement such as cutters.

Where the weight, size or shape of consumables items or machine parts prevents them from being moved by hand they shall be either:

- a) fitted with attachments for lifting devices or;
- b) so designed that they can be fitted with such attachments or;
- c) shaped in such a way that standard lifting devices can easily be attached.

NOTE See EN 1005–2:2003+A1:2008 for guidance.

5.2.5.2 Handling of elements for ground support

When the ground support method requires the handling of elements weighing more than 50 kg, a handling and erecting device shall be fitted. The handling system for ground support elements shall be designed to avoid the need for persons to be present in a danger zone. Where their presence is necessary, starting and movements of the handling system shall be under the control of its operator.

Segment pick-up devices, including vacuum operated attachment pads on segment erectors and other element handling systems shall be designed so that the factor of safety against pull-off and sliding force shall be a minimum of 1,5, taking into account the maximum load. The preferred means of achieving this shall be the provision of a mechanical device (e.g. shear pin), otherwise the factor of safety shall be a minimum of 2,5.

Where segment elements are handled using vacuum attachment pads the system shall be designed to maintain the minimum required vacuum for at least 20 min following failure of the vacuum pump or the energy supply. When the minimum vacuum drops below 80 % an audible and visual alarm shall be activated (see Table 4).

The design of the system should consider the altitude where the machine is in first use. The relevant instruction should be given in the instruction handbook.

All hydraulic and pneumatic rams and motors and vacuum attachment pads which sustain load shall be designed to hold the load in the event of a circuit or power failure, by means of directly mounted pilot operated check valves or power off brakes. For requirements EN ISO 4413 and EN ISO 4414 shall be considered.

In all cases winches and drive motors shall be fitted with mechanical brakes which are automatically released during operation.

5.2.6 Rotation and displacement (axial movement)

5.2.6.1 Rotation

NOTE Tunnelling machinery can be subjected to unintentional slow rotation due to imbalance of loads and forces.

Provision shall be made in the design and manufacture of tunnelling machinery especially those as defined in 3.2 - 3.8 inclusive to avoid eccentric loadings and such tunnelling machinery shall be fitted with a roll indicator, and effective means for roll correction (e.g. bi-directional cutter head, articulated thrust cylinders, ploughs). The manufacturer shall make recommendations for roll correction in the instruction handbook (see 7.3.2).

Sudden rotation of tunnelling machinery as defined in 3.2 – 3.8 may occur when a cutter head or boom is embedded in the face. All such machines shall therefore be fitted with a device which cuts off power to the drive motor in the event of the machine having rotated more than a pre-set angle as defined by the manufacturer.

5.2.6.2 Gripping and regripping

To prevent rotation or sliding backwards of tunnelling machinery equipped with a gripping system (e.g. unshielded tunnel boring machine, telescopic shield machine, shaft boring machine) the control system shall ensure that the cutter head rotation can be activated and the thrust force applied only when the minimum gripping pressure required as defined by the manufacturer has been reached, see 5.5 and Table 3. Information shall be given in the instruction handbook.

If the gripping pressure falls below this minimum, the cutter head rotation and the thrust force shall be shut off automatically.

For tunnelling application with an inclination of 25 % or more to the horizontal, an additional system e.g. independent gripping system shall be provided. An interlock (see Table 3) shall ensure all times the gripping system or the additional system is engaged to prevent the tunnelling machinery from sliding during regripping. The additional system shall be independent of the main hydraulic system and of the main power source. In the case of regripping or loss of power to the tunnelling machinery, it shall be activated automatically. This additional system shall be able to hold a minimum load equal to 1,25 times of the force caused by the downhill component of the self-weight of the tunnelling machinery. For tunnelling applications with an inclination between 15 % and 25 % the need for an additional system for the safe use of the machine in the ground conditions foreseen shall be determined by the tunnel project risk assessment.

5.2.7 Structural collapse of the shield

Shielded tunnelling machines can act as temporary ground support during the tunnelling operations. They shall therefore be designed in accordance with EN 1993-1-1 to withstand the loads imposed by the ground and ground water. In addition operational loads shall be taken into account. The manufacturer shall provide information about the maximum loads considered in the design of the machine in the instruction handbook.

5.2.8 Air locks

Where the intended use of the tunnelling machinery requires an air lock, the air lock shall comply with EN 12110:2014 and shall be installed in accordance with the instructions given in EN 12110:2014.

The structure of the tunnelling machinery shall be designed to accommodate the installation of the air lock.

5.2.9 Rock bolting devices

Where the intended use of the tunnelling machinery requires a rock bolting device, the rock bolting device shall comply with EN 16228-1 and EN 16228-2.

5.2.10 Access to and egress from operating positions and servicing points

5.2.10.1 General

Tunnelling machinery shall be provided with safe access and egress systems which shall meet the requirements of EN ISO 14122 (all parts) with the exceptions as listed in 5.2.10.2 and 5.2.10.3.

The requirement for rescue by stretchers and the wearing of breathing apparatus by rescue personnel shall be taken into account.

The areas of tunnelling machinery where transfer of materials to and from the tunnel transport system takes place shall be designed and constructed to maintain safe walkways, see 5.2.10.2.

All tunnelling machinery shall be provided with clear and unobstructed escape routes for all operatives.

For micro tunnelling machines, where the dimensions of 5.2.10.2 and 5.2.10.3 are not satisfied, entry in the machine shall be prevented by fixed guards.

5.2.10.2 Walkways

For tunnelling machinery of internal diameter more than 6,0 m walkways within the tunnelling machinery shall have a minimum cross sectional area of 1,2 m² within which there shall be a rectangular clear body opening with a vertical dimension of at least 1,9 m and a horizontal dimension of at least 0,6 m.

For tunnelling machinery of internal diameter of more than 3,5 m and equal or less than 6,0 m walkways within the tunnelling machinery shall have a minimum cross sectional area of 0,8 m² within which there shall be a rectangular clear body opening with a vertical dimension of at least 1,4 m and a horizontal dimension of at least 0,45 m. A reduced vertical dimension of 1,0 m shall be acceptable for a continuous maximum length of 4,0 m.

For tunnelling machinery of internal diameter more than 2,0 m and equal or less than 3,5 m walkways within the tunnelling machinery shall have a minimum cross sectional area of 0,6 m² within which there shall be a rectangular clear body opening with a vertical dimension of at least 1,0 m and a horizontal dimension of at least 0,45 m. A reduced vertical dimension of 0,7 m shall be acceptable for a continuous maximum length of 4,0 m.

For tunnelling machinery of internal diameter equal or less than 2,0 m walkways within the tunnelling machinery shall have a minimum cross sectional area of 0,5 m² within there shall be a rectangular clear body opening with a vertical dimension of at least 0,7 m and a horizontal dimension of at least 0,45 m.

Walkway surfaces shall be at least 0,3 m wide and manufactured with a non-slip surface. Handrails and toeboards shall be provided.

Walkways shall be un-obstructed, e.g. by designated storage areas for materials or equipment. Whenever possible, changes in level and alignment of the walkway shall be avoided. Where ramps steps or stairways are necessary, handrails or handholds to at least one side shall be fitted.

5.2.10.3 Access opening dimension

Access openings shall be as large as possible however they shall have a minimum cross sectional dimension of 0,45 m and minimum cross sectional area of 0,35 m².

For tunnelling machinery of external diameter equal or less than 6,0 m the following reduced minimum cross sectional areas shall be acceptable:

Table 2 — Minimum cross sectional area

Minimum cross sectional dimension	Minimum cross sectional area
≤ 3,5 m	0,2 m ²
> 3,5 m ≤ 6,0 m	0,25 m ²

5.2.11 Protection against falling objects, face collapse, rockfall and flood

5.2.11.1 Falling objects

Where there is a risk that objects may fall on any work station or control station, a falling object protective structure according to level 2 of EN ISO 3449:2008 shall be provided.

When driving inclined shafts of 25 % inclination or more to the horizontal, the main control station shall be protected from rolling or falling objects by a barrier designed to withstand the accumulated load or by installing a deflector to prevent the load from accumulating.

5.2.11.2 Face collapse

Tunnelling machinery shall be provided with face support systems designed to be appropriate to the ground conditions for which the tunnelling machinery is intended, see 5.2.4.

5.2.11.3 Rock fall

In unshielded tunnel boring machines equipment for rock support shall be provided. The type and installation area of the rock support elements shall be in accordance with the intended use of the machinery.

All safety critical components such as cables, transformers, hydraulic pipes and hoses shall be protected against rock fall.

5.2.11.4 Flood

Where for the intended use of the machine there is a specific risk of flooding the manufacturer shall make additional provisions to mitigate the risk.

NOTE These provisions can include:

- Equipment for drilling ahead of the machine;
- equipment for pre-excavation grouting;
- pumping equipment;
- safety related and sensitive components to be so installed that additional risks are minimized;
- appropriate seal systems.

These additional provisions shall be described in the instruction handbook.

5.2.12 Pipe jacking rigs

All load transfers between thrust jacks and pipes in pipe jacking rigs, thrust boring machines and auger boring machines shall be by means of purpose designed spacers and thrust rings. Thrust jacks shall be supported perpendicular to a thrust ring such that no bending shall occur during jacking operations.

The manufacturer shall provide information on the safe use of pipe jacking rig, see 7.3.2.

5.3 Control stations

5.3.1 General

Control stations shall be designed, positioned and protected to ensure that operators are not exposed to mechanical hazards, harmful dust, gases, vapours, noise emissions (see 5.9.3) or heat. For the main control station such protection shall preferably be by means of a cab.

5.3.2 Ergonomics

The operator's position shall meet the requirements of EN ISO 3411, except for tunnelling machinery of less than 2 m diameter where the size of the machine does not provide adequate space. The operator's seat, when fitted, shall in all cases keep the operator in a stable and comfortable position, for dimensions see ISO 11112. The seat shall also meet the requirements of EN ISO 7096.

5.3.3 Visibility

Visibility from a control station shall be such that the operator has a clear view of the controlled working area. Where necessary, visual aids, for example closed circuit television, shall be used.

5.4 Guards and protective devices

5.4.1 General

Where the risk due to moving parts exists, those parts of the tunnelling machinery shall be fitted with guards according to 5.4.2 to prevent risk of contact with moving parts which can lead to accidents. In addition, where moving parts are exposed adequate warning signs in accordance with ISO 3864-1:2011 shall be positioned so as to be readily visible to persons on the machine.

5.4.2 Design of guards

Design of guards shall be in accordance with EN ISO 12100, EN ISO 3457 or EN 953:1997+A1:2009.

5.4.3 Belt conveyor

Belt conveyors shall comply with the requirements of EN 620:2002+A1:2010 and belts of conveyors shall comply with EN 14973:2006+A1:2008.

The machine conveyor belt drive shall be fitted with a key switch for the activation of creep speed.

5.4.4 Access to excavation chamber, cutter head or other digging equipment

Access to the excavation chamber or the area where contact with the cutter head can occur shall only be possible when the cutter head has been brought to a complete standstill (see 5.2.4, 5.5.1 and 5.17.2).

Access openings to the excavation chamber shall be protected by interlocked doors or guards. Opening a door or guard to the excavation chamber shall cut off the power supply to the cutter head motors and to other appliances in the excavation chamber e.g. crusher, screw conveyor, agitators (see Table 3).

On tunnelling machinery incorporating a full face cutter head, a control station for use only during cutter head maintenance shall be provided in the excavation chamber. This control station has to be selected on the main control station by a lockable mode selector. When this mode is selected, it shall cut off the power supply to the cutter head motors and to other appliances in the excavation chamber e.g. crusher, screw conveyor, agitators (see Table 3) and deactivate the interlocking door or guard.

When this control station has been activated, control of movement of the cutterhead and of other appliances in the excavation chamber shall only be possible from this control station in creep or jog mode only.

To re-establish the normal function it is necessary to:

- deactivate the additional control station in the excavation chamber;
- close the access openings with interlocked doors or guards;
- select the normal mode with the lockable mode selector at the main control station.

Where a partial face excavation equipment is mounted in front of a bulkhead in the shield, the same requirements shall apply.

On a shield machine with a direct visibility to the partial face excavation equipment from the main control station, see Figure A.1, it is possible to have only a lockable mode selector at the main control station instead of having a separate maintenance control station.

When creep or jog operation is actuated, an automatic warning signal shall be activated (see 5.5.5).

During work in the excavation chamber, in or in front of the cutter head an access to the excavation chamber with at least the minimum access opening dimensions (see 5.2.10.3) shall be maintained at all times.

Adequate anchoring points for safety harnesses shall be provided for personnel working on the cutter head. For guidance see EN 363. Where there is no access to the excavation chamber or cutter head, the provisions of this clause do not apply.

The manufacturer shall provide full operating instructions in the instruction handbook.

5.4.5 Auger extensions during jacking operations

For microtunnelling machines with augers and auger boring machines (as defined in 3.8 and 3.10) there shall be a reduced speed mode for auger jointing operations. This mode shall be activated by a mode selector.

NOTE Movement includes linear as well as rotational movement.

5.5 Control systems

5.5.1 Safety and reliability of control systems

The parts of the control system which implement the safety function of tunnelling machinery shall conform to the requirements of EN ISO 13849-1.

The required Performance Level (PL_r) for safety functions shall meet the minimum PL_r detailed in Table 3 below.

Table 3 — Required Performance Level (PL_r)

Safety function	Required Performance Level (PL_r)
5.2.4 drift away of cutter head	d
5.2.5.2 sustain load in the event of circuit or power failure	d
5.2.6.2 minimum gripping pressure interlock	b
5.2.6.2 additional independent gripping system interlock	d
5.4.4 access door or guards interlock	c
5.5.4.3 emergency stop device	c/d a)
5.8.4.3. automatic shut down	c
a) according to the risk assessment	

All remaining safety related parts of control systems shall meet as minimum the Performance Level (PL_r) “a” according EN ISO 13849-1.

An interlocking system shall prevent any function from being operated from more than one control point simultaneously. This system shall not however prevent all emergency stop controls remaining active.

5.5.2 Control devices

Control devices shall conform to the requirements of EN 894-3:2000+A1:2008 and shall be:

- clearly visible and identifiable and appropriately marked;
- designed or protected in such a way that the desired effect can only be achieved by an intentional actuation;
- for start and stop controls not operated by the same device, they shall be located close to each other;
- within reach of the operator at the operator’s position;
- logically grouped;
- so arranged that the layout and movement are compatible with the action to be performed and be ergonomically designed;
- of a hold-to-run type for creep or jog operation.

Where local control devices are provided mainly for maintenance purposes they shall be hold-to-run type and be provided with a key to switch off the operation of that part of the tunnelling machinery.

Where a control device is designed and constructed to perform several different actions, the action to be performed shall be clearly displayed and subject to confirmation.

Tunnelling machinery shall be fitted with devices which shall indicate actual working levels of activities in the main control station. The operators shall be able to read them from their control stations.

5.5.3 Remote control

All remote control systems shall comply with ISO 15817.

5.5.4 Starting and stopping

5.5.4.1 Starting

It shall be possible to start tunnelling machinery only by intentional actuation of control devices provided for the purpose.

The same requirement applies, when restarting tunnelling machinery after a stoppage, whatever the cause.

Where starting and/or stopping of parts of tunnelling machinery needs to be performed in a specific sequence, there shall be devices which ensure that these operations are performed in the correct order.

These parts include:

- conveyance systems which shall be started in order from the final point of discharge to the initial point of feeding. Stopping shall be in the reverse order;
- gripping systems (see 5.2.6.2) which shall be engaged before extension of the main shove rams.

5.5.4.2 Normal and operational stop

Tunnelling machinery shall be fitted with stop controls whereby the machinery can be brought safely to a complete stop.

Each control station shall be fitted with control devices to stop the functions of the tunnelling machinery which are controlled from that station (see also 5.2.4; 5.2.5; 5.2.6). Stop controls shall have priority over the start controls. All normal operational functions, which are sequentially started or stopped, shall be capable of being started and stopped individually for maintenance purposes.

5.5.4.3 Emergency stop

All tunnelling machinery shall be fitted with emergency stop devices at each control station and positions defined in 5.7.2.8 of EN 620:2002+A1:2010. Emergency stop devices shall conform to EN ISO 13850 and shall comply with categories 0 or 1, as applicable and in particular:

- a) be clearly identifiable, clearly visible and quickly accessible;
- b) stop the parts of the machine controlled from that station as quickly as possible, without creating additional risks e.g. back-running conveyor.

5.5.4.4 Mode selector

Mode selection by itself shall not initiate machine operation. A separate actuation of the start control shall be required.

Indication of the selected operating mode shall be provided (for example the position of a mode selector, the provision of an indicating light, a visual display indication).

5.5.5 Warning system

5.5.5.1 Moving equipment warning

A warning system shall be fitted to moving equipment such as conveyors, cutter heads and erectors as required in Table 4. The warning system shall be electrically interlocked with the control system in accordance with the requirements of 5.5.1. EN 981:1996+A1:2008 gives specifications for different signals. Sound warning systems shall have a minimum sound level at least 10 dB above the expected ambient machinery noise level under operating conditions.

Table 4 — Audible and visible warning systems

Function	Operating conditions	Type of Warning	Duration	Location of perception
Jog operation of the cutter head		Audible	5 s before start up	At the cutter head area
Operation of a conveyor		Audible	5 s before start up	Along the whole length of the conveyor
Movement of the erector	At all times including during boring	Visible	during rotation movement	In ringbuild area
Movement of the back-up equipment independently of the boring process		Audible and visible	5 s before start up	Be heard and seen in the back-up equipment
Start-up of the cutter boom or back-acter		Audible	5 s before start up	At cutter boom area
Unintentional loss of vacuum on vacuum pick up devices	At all times including during boring	Audible and visible	Continuous	In ringbuild and lifting area

5.5.5.2 Emergency evacuation warning system

An emergency warning system shall be fitted as required in Table 5. EN 981:1996+A1:2008 gives specifications for different signals. Emergency warning systems shall have a minimum sound level at least 10 dB above the expected ambient machinery noise level under operating conditions and shall be readily distinguishable from the function warnings listed in Table 4.

The emergency warning system is an essential service which shall be maintained for at least 1 h.

Table 5 — Audible emergency evacuation warning system

Fault conditions	Type of Warning	Duration	Location of perception
Emergency evacuation	Audible see Table 2 of EN 981:1996+A1:2008	Continuous	Along the whole length of the back-up equipment

NOTE Emergency can include fire, flood or hazardous atmosphere. The response to the emergency is the responsibility of the user.

5.5.5.3 Warning Devices

Warning devices (audible or visible) shall be of robust design and construction and sited where they cannot be easily damaged.

5.5.6 Failure of power supply

An interruption, re-establishment after an interruption or fluctuation of the power supply to the tunnelling machinery shall not lead to a hazardous situation. In particular provision shall be made for the following:

- after re-establishment of the power supply the tunnelling machinery shall only start after an intentional actuation of the start controls;
- the tunnelling machinery shall not be prevented from stopping if the command to stop has already been given;
- the safety measures relating to the access to the cutter head shall remain fully effective.

In the event of failure or interruption of the main power supply power essential services shall automatically be maintained, see 5.5.5.2, 5.8.4.2, 5.8.4.3 and 5.10.8.

5.6 Towing connection

Each individual towing connection within the tunnelling machinery shall be designed and constructed to withstand the tractive force normally required to tow the relevant towed back-up equipment with safety factors as follows:

Table 6 — Safety factors

Towing connection	Safety factor
Chain connections	A factor of 4 on the breaking load
Bars and other connections	A factor of 2 on the yield stress
Hydraulic towing cylinders	A factor of 2 on the towing force

Steel cables shall not be used as towing connections.

In order to avoid overload, the towing connections between machine and towed back-up equipment shall be monitored (e.g. hydraulic pressure, load measuring device).

For the calculation of the tractive force the following friction factors shall be applied:

Table 7 — Friction factors

Calculation of tractive force	Friction factor
For wheel mounted trailers when they run on rail track	$\mu = 0,2$
For wheel mounted trailers when they run on other surfaces	$\mu = 0,3$
For sledge mounted trailers on any surface	$\mu = 1,0$

When the back-up equipment is moved independently, a warning system according to 5.5.5.1 shall be provided. Where the inclination of a tunnel is such that in the event of failure of the towing connection the backup equipment could move due to gravitational forces, a second independent towing connection shall be provided.

For duty in inclined tunnels at an inclination of 25 % or more to the horizontal, the above mentioned safety factors shall be increased by a factor of 1,5.

When driving downhill only bars or hydraulic towing cylinder shall be used and shall be designed according to the gradient of the tunnel.

5.7 Laser guidance

The laser window shall be positioned so that exposure of the eyes of personnel to the laser beam is minimized and signs warning against excessive exposure shall be provided.

Low power lasers designed up to class 3R of EN 60825-1 shall be used.

NOTE The laser is not part of the machine.

5.8 Ventilation and the control of dust and gas

5.8.1 General

The tunnelling machinery shall incorporate ventilation and dust control (dust suppression and collection equipment) where appropriate. The manufacturer shall contribute to dust control by a combination of reduction in dust produced, dust suppression and dust extraction.

Dust control should ensure that exposure to dust (respirable quartz and total dust) does not exceed national limits during intended use of the machines.

5.8.2 Dust control

5.8.2.1 Dust suppression

The dust suppression system shall be incorporated into the cutter head or the excavation chamber and any other position where dust is generated. This shall control the dust and prevent it moving along the tunnelling machinery.

NOTE This can be done by water sprays, air flow, extraction and any combination of these.

5.8.2.2 Dust collection

The dust collection system shall be capable of operating in both wet and dry atmospheric conditions. Dust removed from the atmosphere shall be removed from the tunnel without discharge back into the atmosphere. The system shall be designed to require a minimum of maintenance. Maintenance points and control points on such equipment shall be easily accessible and well illuminated.

NOTE Dust can be discharged as a slurry into the tunnel spoil handling system or removed by means of a dedicated dust handling system.

5.8.3 Ventilation

The ventilation system shall provide sufficient air flow in all sectors of the tunnelling machinery in accordance with national requirements.

5.8.4 Atmospheric changes and ingress of gases

5.8.4.1 General

Tunnelling can present a range of hazards due to atmospheric contamination. This can be due to ingress of gases from the surrounding ground. These gases can be toxic, flammable, radioactive or can simply lead to a reduction in the concentration of oxygen within the normal air to a harmful level.

The ventilation system shall provide sufficient air flow in all sectors of the tunnelling machinery to maintain a safe oxygen concentration and to reduce the concentration of dangerous gases to values below the national exposure limits.

5.8.4.2 Monitoring equipment

All accessible tunnelling machinery as defined in 3.2 to 3.7 shall be fitted with explosion protected atmospheric monitoring equipment capable of detecting oxygen deficiency and methane.

All atmospheric monitoring devices shall give a visible readout and audible warning at the main operator's position.

Methane monitoring sensors shall be mounted at the following positions:

- at the highest point of the cross-section directly behind the cutter head or dust shield;
- in the outflow of the dust removal system;
- in the unloading/transfer points of the muck-conveyance.

For micro tunnelling machines, where the dimensions of 5.2.10.2 and 5.2.10.3 are not satisfied, and entry even for maintenance in the machine has been prevented by fixed guards, monitoring equipment shall be positioned on the jacking rig and in the surface operations container whenever this is situated over the working shaft.

Such equipment is an essential service and shall be maintained for at least 24 h. Provision shall be made for housing additional equipment to monitor toxic gases and radiation that may be considered likely to occur in the ground conditions for which the tunnelling machinery is intended to be used.

5.8.4.3 Provisions for methane ingress

Unless the intended use of the machinery specifically excludes the risk of methane ingress all electrical equipment in the air flow of the dust collection system shall be explosion protected in accordance with EN 60079-0, equipment-group II.

The monitoring system shall give a visible and audible alarm when the preset alarm value specified by national regulations or standards is reached. In the absence of national regulations or standards a preset alarm value of 1 % methane in air by volume shall be used.

When the preset shut-down value specified by national regulations or standards is reached all electrical and mechanical equipment which is unsuitable for use in an explosive atmosphere shall be shut down immediately and automatically. In the absence of national regulations and standards a preset shut-down value of 1,5 % methane in air by volume shall be used.

The following equipment, which shall be explosion protected, shall continue to function following an automatic shutdown:

- atmospheric monitoring equipment, see 5.8.4.2;
- emergency lighting;
- evacuation alarm system;
- other systems identified by the project risk assessment.

5.8.5 Internal combustion engines

Internal combustion engines shall only be used for emergency purposes on tunnelling machinery e.g. for emergency power supply, and then only when appropriate ventilation equipment is incorporated to meet national exposure limits.

Internal combustion engines driving hydraulic power packs for pipe jack rigs and microtunnelling machines, auger boring machines and thrust boring machines shall be designed to allow for exhaust systems to discharge clear of tunnel and shaft openings.

5.9 Noise

5.9.1 General

Tunnelling machinery shall generate noise levels as low as possible and practicable. Therefore noise reduction shall be an integral part of the design process taking into account measures at source as very generally described in EN ISO 11688-1:2009.

The main noise sources include process noise, hydraulic equipment, electric motors, ventilation equipment, slurry pump.

5.9.2 Noise reduction at source at the design stage

When designing tunnelling machinery the available information and technical measures to control noise at source at the design stage shall be taken into account, according to EN ISO 11688-1:2009 and in particular the use of components and ancillaries with lowest possible noise emission.

NOTE EN ISO 11688-2:2000 gives useful information about noise generation mechanisms in machinery.

Noise shall be reduced by the following measures:

- electric motors as of 250 kW capacity and above shall be water cooled;
- pumps and motors shall not be mounted directly on the steel structure of the machine but shall be separated from the structure by vibration isolation mountings;
- for tunnelling machinery of internal diameter more than 6.0 m noise reducing enclosures shall be provided around hydraulic power packs;
- for tunnelling machinery of internal diameter of more than 3,5 m and equal or less than 6,0 m noise reduction enclosures should be provided around hydraulic power packs;
- fans which are part of the permanent ventilation system of the tunnelling machinery shall be fitted with silencers;
- reducing noise emission caused by vibration;
- control cabin with noise protection.

5.9.3 Information on residual risk

Information on residual risk i.e. noise emission values shall be given to the user, see 7.3.1.

5.10 Electrical equipment

5.10.1 General

All electric equipment shall comply with the relevant parts of EN 60204-1 or EN 60204-11 depending on voltage used and as supplemented below.

5.10.2 Protective measures

The circuits for portable equipment, accessories and lighting shall comply with Clause 15 of EN 60204-1:2006 with the addition of the following:

The measures to mitigate the problems associated with electrical equipment in a tunnel environment shall include:

- a) the use of residual current protective device with a fault current rating of a maximum of 30 mA, see EN 61008-1;
- or
- b) the use of 110 V centre earth tap supply.

NOTE This system is predominantly used in the UK.

Control circuits shall comply with Clause 6 of EN 60204-1:2006. In power circuits up to 1000 V a residual current protective device or an insulation monitoring system shall be installed in accordance with the type of supply system. In the case of insulation monitoring, when a reduction of the insulation resistance to less than 100 ohm/v occurs the failure shall be indicated by means of a visible or acoustic signal. Trailing cables and power cables in micro tunnelling machines operating on a voltage above 1000 V shall be able to be monitored by devices which shall immediately shut off the power supply under any of the following conditions:

- a) interruption of the protective earth or the monitoring conductor;
- b) a short circuit between the protective earth conductor and the monitoring conductor;
- c) a short circuit between a phase conductor and the protective earth conductor;
- d) a short circuit between a phase conductor and the monitoring conductor;

e) a short circuit between phase conductors.

It shall not be possible automatically to reconnect the power supply following a disconnection.

NOTE The effectiveness of this device depends of the user of the machine installing appropriate equipment in the tunnel or on the surface.

5.10.3 Cables

All conductors and cables shall be selected in accordance with Clauses 12 and 13 of EN 60204-1:2006. In addition, insulated power cables shall be oil and water proof and have low smoke and flame resistant characteristics.

When cables are wound on drums the current load factor shall be reduced in relation to the straight cable rating as a function of the number of windings in accordance with the cable manufacturer's specification.

5.10.4 Transformers

Only the following transformers shall be used on tunnelling machinery:

- air cooled transformers;
- fluid cooled transformers using synthetic coolants and insulating fluids with flash points above 300 °C (EN 60076-2, classification K).

An air cooled transformer shall not be adversely affected by dust in the cooling air.

5.10.5 Bonding

In addition to the specification of Clause 8 of EN 60204-1:2006 an equipotential bonding conductor shall be installed within the boundaries of the tunnelling machinery. All electrically conductive components of the tunnelling machinery which are individually insulated shall be connected to the bonding conductor in accordance with EN 61439-1:2011, 8.4.3.2.3, shall be connected together and to an equipotential conductor. The material for the bonding conductor shall be copper braid and the cross-section shall be in accordance with EN 61439-1:2011, 8.4.3.2.3.

Where there is a risk of mechanical damage, the minimum cross-section area of the conductor shall be a minimum of 50 mm².

NOTE National regulations can require the cross-section of the bonding conductor to be larger than that required by EN 61439-1.

5.10.6 Switch gear

All low voltage switch gear shall comply with the relevant provisions of EN 61439-1, EN 60439-2, EN 60439-3, EN 60439-4 and EN 60947-1 and shall, where space permits, be installed in cabinets or boxes.

The cabinets or boxes shall have protection to at least class IP 55 and shall be arranged or built to protect the switch gear against mechanical damage. Switch gear outside such a cabinet or box shall have at least protection class IP 55 with mechanical protection where equipment may be subjected to mechanical damage.

The degree of protection provided by an enclosure shall be indicated by the IP Code as described in Clause 4 of EN 60529:1991.

5.10.7 Lighting

The lighting shall comply with EN 1837:1999+A1:2009. Working areas shall be illuminated to a level of at least 100 lux. Illumination at the level of an operator's controls shall be adjustable up to at least 100 lux.

The illumination shall be 30 lux at walkway level. Where service work is intended to be carried out sockets for additional lighting shall be provided.

Light fittings shall be mechanically protected.

For example, they may be installed in glass domes with a protective armoured cage or mounted in domes made of high impact resistant material.

Care shall be taken to mitigate the affect of glare and shadow.

5.10.8 Emergency lighting

Emergency lighting is an essential service and shall be maintained for at least 1 hour.

The level of illumination provided at walking level by the emergency lighting shall be at least 15 lux.

5.10.9 Electromagnetic compatibility (EMC)

Tunnelling machinery shall be designed to avoid any EMC incompatibility between components.

The parts of tunnelling machinery located above ground level, such as pipe-jacking, micro-tunnelling power packs shall adhered to the requirements of EN 13309.

NOTE Tunnelling machinery operating below ground level does not present a significant EMC hazard to machinery operating on the surface.

5.10.10 Isolation of high voltage power supply

Devices for isolation of the mains supply (on both the high and low voltage side of the transformer) shall be provided. Such devices shall be lockable in the open position.

5.11 Hydraulic and pneumatic systems

Hydraulic pumps and motors, control systems and the interconnecting pipe work and hoses shall be designed and constructed according to EN ISO 4413. Adequate shielding in accordance with Clause 9 of EN ISO 3457:2008 shall be provided to protect persons in working areas.

In addition the following requirements shall be met:

- a) non-toxic hydraulic fluids shall be used;
- b) only low-flammability hydraulic fluids shall be used conforming to EN ISO 12922;
- c) all hydraulic systems shall be designed so that in the event of rupture of a component the loss of hydraulic fluid is minimised and early warning is given of the rupture. Hydraulic tanks shall be fitted with low and high level warning alarms;
- d) hydraulic cylinders used for lifting shall be fitted with load-sustaining devices mounted on the cylinder;
- e) hoses and pipes which have to be disconnected in operation shall be fitted with self sealing couplings with built-in check valves, couplings shall be marked to ensure correct reconnection;
- f) a temperature monitoring system which gives a readout at the control panel and a visual warning if the maximum permissible temperature of the hydraulic fluid is exceeded shall be provided in the hydraulic system;
- g) electrically operated valves shall be protected to at least IP 55 in accordance with EN 60529.

Compressors, air motors, control systems and pneumatic accessories and interconnecting pipework and hoses of any pneumatic system shall be designed and constructed according to EN ISO 4414.

Within the system in which the accumulator is fitted it shall be possible to isolate the accumulator and separately to dissipate the energy from it.

All control devices and systems shall meet the requirements set out in 5.5.

5.12 Fire prevention and protection

5.12.1 General

Tunnelling machinery shall be designed to avoid the risks of fire (see EN 13478:2001+A1:2008). In particular the following shall be considered:

- a) reduce sources of ignition, for example, short circuits in electrical systems, hot surfaces, lack of lubrication, hydraulic oil sprays and lubricating oil leakage and grease leakage;
- b) reduce the combustible inventory to a minimum, for example by using fire-resistant materials in accordance with ISO 3795;
- c) timber shall not be used for any structural application on tunnelling machinery or for walkway surfaces;
- d) install a fire extinguishing system.

All tunnelling machinery shall be fitted with a fire detection system and with the means for raising the alarm in the event of a fire being detected, for details see 5.5.5.2, Table 5.

5.12.2 Fixed fire extinguishing systems

All tunnelling machinery shall be equipped with fixed fire extinguishing systems.

The parts of tunnelling machinery to be equipped with fixed fire extinguishing systems includes power units, e.g. motors, transformers, hydraulic power packs and electrical cabinets for tunnelling machinery and areas with concentrations of hydraulic hoses, hydraulic tanks, electrical cables and lubricants.

The systems shall be filled with appropriate extinguishing agents for the fire risks envisaged. Each system shall be activated either by manual operation or automatic operation. Each system once activated, shall be capable of discharging extinguishant over a predetermined area of the tunnelling machinery without the need for further human intervention. For equipment within enclosures, discharge shall be within that enclosure.

NOTE 1 Gas extinguishant is only effective in enclosure.

Potential risk for operator(s) should be considered.

The fixed fire extinguishing system shall be supplemented by portable fire extinguishers for minor fires (see 5.12.3).

NOTE 2 For maintenance and servicing it might be preferable to have fire extinguishing systems supplied from local suppliers.

5.12.3 Installation of portable fire extinguishers

Portable fire extinguishers shall be distributed along the tunnelling machinery including at all operator control points. They shall be easily accessible and clearly marked. Each shall be filled with a minimum of 6 kg of an appropriate extinguishing agent. Portable extinguishers shall fulfil the requirements of EN 3-7:2004+A1:2007.

NOTE In confined spaces powder extinguishants can present a health hazard and cause damage to tunnelling machinery.

5.12.4 Water curtain on towed back-up equipment

The rear of the towed back-up equipment shall be fitted with a water curtain system. This shall provide a curtain of water across the whole of the tunnel cross section for smoke control purposes. It shall be capable of being activated manually and its operation shall not depend on the main electrical power supply.

5.13 Storage of rescue equipment

Readily accessible storage space shall be provided on all towed back-up equipment for personnel rescue equipment, e.g. stretchers, breathing apparatus and first aid equipment.

Such space shall be clearly marked and protected against dust and moisture.

5.14 Refuge chamber

Refuge chamber where provided shall comply with Annex D.

5.15 Probe drilling equipment

All tunnelling machinery as described in 3.2 to 3.5 of 3,0 m outside diameter and above, shall be designed to allow for the future installation and use of forward probe drilling equipment e.g. by the installation of a stuffing box and valve.

Where the intended use of the tunnelling machinery requires probe drilling equipment, it shall comply with EN 16228-1 and EN 16228-2.

The size and type of equipment for which provision has been made shall be given in the instruction handbook.

5.16 Transportation, lifting and assembly

5.16.1 Transportation

To transport tunnelling machinery or parts of tunnelling machinery safely, instructions for tie-down points shall be provided in the operation manual.

5.16.2 Lifting

Lifting points shall be provided and be designed for the mass envisaged for transportation and shall be clearly identified on machines or subassemblies that are to be lifted in one piece. The method of lifting heavy attachments, components and machines shall be described in the operation manual (see 7.3.2). If lifting points have to be removed after assembly, instructions for their replacement shall be included in the information for use.

For lifting symbol, see ISO 6405-1:2004, symbol 7.23.

5.16.3 Assembly

The design of the tunnelling machinery shall take into account the need to assemble it on the job-site.

The manufacturer shall give safety related instructions for assembly, installation and connection, including drawings and diagrams.

5.17 Maintenance

5.17.1 General

Tunnelling machinery shall be designed so that adjustment, maintenance, repair, cleaning and servicing operations can be carried out when the machinery is at a standstill and in a safe configuration.

Where it is necessary to undertake checks or maintenance with the machinery in operation, safe procedures shall be developed including the use of local control stations at which operation in creep speed or jog (see 5.4.4, 5.4.5, 5.5.4.2) can be engaged.

Safe procedures shall be described in the instruction handbook.

5.17.2 Work on cutter heads or shield-mounted cutter booms and excavators

Where access to the cutter head, boom or excavator of tunnelling machinery is required for maintenance purposes, access ways and shield bulkhead openings shall be provided in accordance with 5.2.10.

Tunnelling machinery shall be designed so that maintenance can be carried out from a position within the protection of the shield or other protective structure, see 5.2.4.

Provision shall be made so that the rotation of motors for the cutter head or the power to the boom or excavator shall be shut off and locked against unintentional restart, see 5.5.4.

5.17.3 Work on micro tunnelling machines

Where access for maintenance in accordance with the dimensions set out in 5.2.10 is possible and required on micro tunnelling machines, special arrangements and procedures shall be developed and described in the maintenance handbook.

6 Verification of the safety requirements and/or protective measures

Verification of the compliance with the safety requirements given in this European Standard shall be made by design check, calculation, visual verification, measurement or functional testing preferably during manufacture and shop assembly at the factory, see Annex B (normative).

NOTE In some machinery, the verification can be done only after the first assembly on site.

7 Information for use

7.1 General

On delivery of the tunnelling machinery, the manufacturer shall provide information on its safe operation and maintenance. This shall be drawn up according to EN ISO 12100:2010, 6.4.

The instruction handbook is part of the machine and is important for the safe and proper operation, maintenance and service of the machinery. The text shall be simple, adequate and complete. The information shall be comprehensive and explicit.

7.2 Emergency information, warning signs and symbols

7.2.1 Warning signs

Warning signs shall comply with ISO 3864-1:2011 and are dealt with in 5.2.2, 5.4.1 and 5.7.

Warning signs shall be made of non-corrosive material, the text shall be durable and the warning signs shall be permanently fastened. The text shall be in one of the official languages of the area or the country of first use.

7.2.2 Warning devices

Warning devices, see 5.4.4, 5.5.5, 5.6, 5.8.4.2, 5.11, D.3 and D.4, shall be unambiguous and easily perceived.

7.2.3 Symbols

Symbols used on tunnelling machinery shall be selected from appropriate ISO and EN standards (see particularly EN 61310-1, ISO 3864-1:2011).

7.2.4 Emergency information

A schematic drawing, showing as a minimum the escape routes, emergency equipment storage locations, refuge chamber (if provided) and fire-fighting installations shall be displayed close to the entrance of the back-up equipment and also be included in the instruction handbook.

7.3 Instruction handbook

7.3.1 General

The instruction handbook shall be provided in the official Community language or languages of the Member State in which the instruction handbook is placed on the market and/or place of first use.

The instruction handbook shall be either an 'Original handbook' or a 'Translation of the original handbook', in which the translation shall be accompanied by an original handbook.

On the front cover or first page of the handbook the following information shall be given as a minimum:

- title of handbook with revision number and date of revision;
- designation of the series or type of machine;
- serial or identification number of the machine;
- the business name and full address of the manufacturer and, where applicable, his authorised representative.

The handbook shall contain:

- a technical description of the machinery in accordance with the marking requirements, see 7.4;
- information on the ground and ground water conditions for which the machinery is designed;
- details of the loading conditions for which the machinery is designed;
- the maximum inclination for which the machinery is designed;
- specific instructions for gripping and re-gripping in inclined shafts, see 5.2.6.2;
- a specification of the intended use of the machinery;
- instructions for the use of the air lock in accordance with EN 12110, if installed;
- a specification of the identified hazards and the measures to be taken for safe operation;
- a statement that the operators shall be given practical training in the operation of the machinery with special emphasis on the relevant safety precautions including fire fighting;
- a general view of the machinery in the form of drawings, photographs, videos, etc. and, diagrams for circuits and networks;
- details of the size and type of ground support for which the machinery has been designed (if relevant) and details of the size and type of rolling stock envisaged by the machine designer;
- details of the size and type of forward probe drilling equipment which the machine has been designed to incorporate, see 5.2.11.4 and 5.15;
- details of the pre-excavation grouting equipment which the machine has been designed to incorporate, see 5.2.11.4;
- information on the use of refuge chamber, see Annex D;
- the noise declaration according to Annex C, C.5;
- information on vibration:

- information on hand-arm vibration if this value exceed $2,5 \text{ m/s}^2$. Experience has shown that the magnitude of hand-arm vibration of tunneling machinery is in general significantly below $2,5 \text{ m/s}^2$. In this case it is sufficient to mention that the acceleration is below this limit;
- information on the highest root mean square value of weighted acceleration to which the whole body is subjected, if this value exceeds $0,5 \text{ m/s}^2$. Where this value does not exceed $0,5 \text{ m/s}^2$, this shall be mentioned. The particular operating conditions of the equipment relevant for the determination of this single value shall be indicated. Experience has shown that the highest root mean square value of weighted acceleration to which the whole body is subjected is in general below $0,5 \text{ m/s}^2$. In this case it is sufficient to mention that the acceleration is below this limit;
- the uncertainty of measurement, if relevant.

NOTE Hand-arm and whole-body vibration are not significant risks.

- information on the personal protective equipments to use, in particular adequate hearing protectors;
- safety related instructions for assembly, installation and connection, including drawings and diagrams;
- information of the commissioning, operation and maintenance of the fire protection system;
- information concerning the altitude limitations of the vacuum lifting systems;
- information concerning the capacity of the emergency dewatering system.

For reference see EN ISO 12100:2010, 6.4.2 and 6.4.5.

Specific instructions regarding gripping and regripping shall be given in the instruction handbook.

7.3.2 Operating instructions

The handbook shall contain operating instructions covering:

- complete instructions for the intended operation;
- warnings concerning ways in which the machinery shall not be used that experience has shown might occur;
- a description of the controls and their function;
- an explanation of any symbols used;
- list and location of the warning signs, warning devices and symbols displayed on the machine;
- a specification of how and where the emergency stops according to 5.5.4.3 are installed and function;
- a nomenclature of major components, their functions, locations and relationship within the whole machine shall be listed;
- detailed instructions covering the use of guards, for example that conveyors shall not be used unless guards are in place;
- information regarding the use of the segment handling system, if installed;
- information regarding the use of the pipe-jacking rig, if installed;
- information concerning risks which remain despite the inherent safe design measures, safeguarding and complementary protective measures adopted and the necessary warnings;
- information concerning the operation and maintenance of the fixed and portable fire prevention and protection measures with respect to the intended use of the machine and warnings of any residual fire risk;

- information concerning escape routes, see 7.2.4 and rescue equipment storage locations, see 5.13, 5.14;
- instructions for carrying out roll corrections, see 5.2.6.1;
- information regarding the minimum gripping pressure required before the cutter head can be activated and thrust force applied, see 5.2.6.2.

7.3.3 Maintenance

The handbook shall contain:

- instructions for carrying out safe maintenance operations:
 - with the machine in a “zero energy state” (including disconnecting the power supply, with provisions against reconnection, dissipation of accumulated energy, testing of safe state);
 - where the machine cannot be completely disconnected from the power supply or when accumulated energy cannot be released or when maintenance work can only be carried out with one or more motors running;
 - on micro tunnelling machines where man entry is permissible see 5.17.3.
- instruction for safe work in the excavation chamber or in the cutter head, see 5.4.4;
- special instructions for changing cutters not accessible from behind and including in unstable ground conditions, see 5.2.4;
- special instructions for counteracting cutter head drift, see 5.2.4;
- instruction that while work is carried out on the cutter head of a machine, no work or tests of any electric or hydraulic system which could have an influence on the control systems of the cutter head, shall be carried out, see 5.4.4 and 5.17.2;
- instructions for the safe assembly and dismantling of parts which are heavy or difficult to handle. The weight of parts which are frequently replaced, e.g. cutters, shall be stated;
- a list of parts, which are classified by the manufacturer to be of particular importance for safety with instructions for the frequency of checking and instructions for replacement. The handbook shall contain data for the identification of parts and their location on the machine. It shall contain a spare parts list and a list containing specifications for all spare parts;
- special warnings about actions which can cause injuries to the maintenance personnel or other personnel;
- recommendations regarding the periodic testing of stop controls, emergency stops, gas warning systems, brake systems and audible warning systems. Specification of regular cleaning of equipment, e.g. transformers.

For reference see EN ISO 12100:2010.

7.4 Marking

The minimum markings on the machinery shall include:

- a) business name and full address of the manufacturer and, where applicable, his authorised representative;
- b) designation of machinery;
- c) designation of series or type, if any;
- d) serial or identification number, if any;

- e) electrical power rating information;
- f) weight;
- g) mandatory marking¹⁾;
- h) year of construction, that is the year in which the manufacturing process is completed.

¹⁾ For machines and their related products intended to be put on the market in EEA, CE marking as defined in the applicable European directive(s), e. g. Machinery, low Voltage, Explosive Atmosphere, Gas appliances.

Annex A (informative)

Examples of tunnelling machines

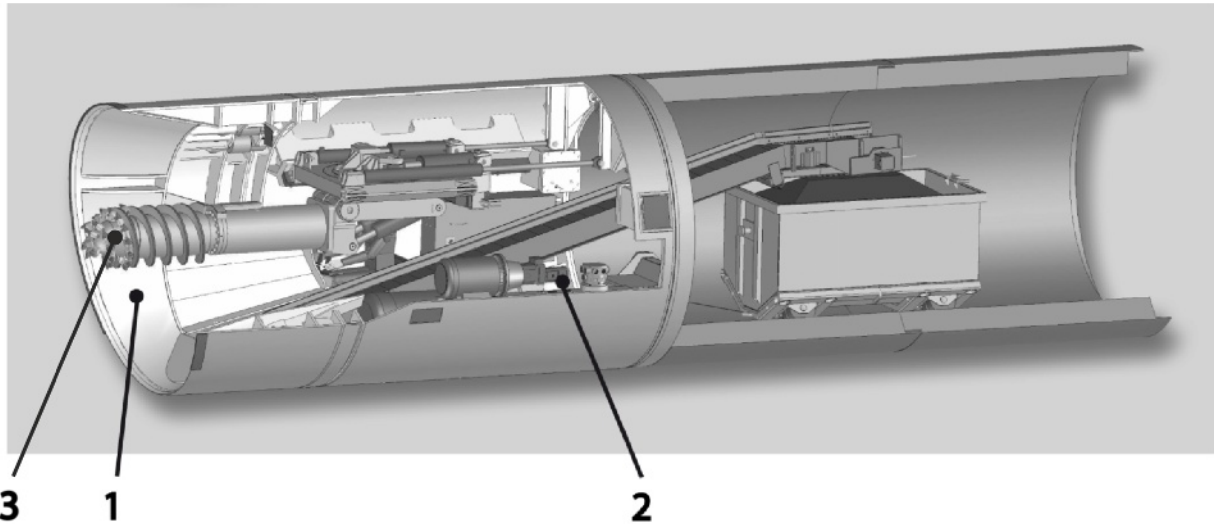

Key

- 1 excavation chamber
- 2 servicing point
- 3 cutter boom

Figure A.1 — Shield machine

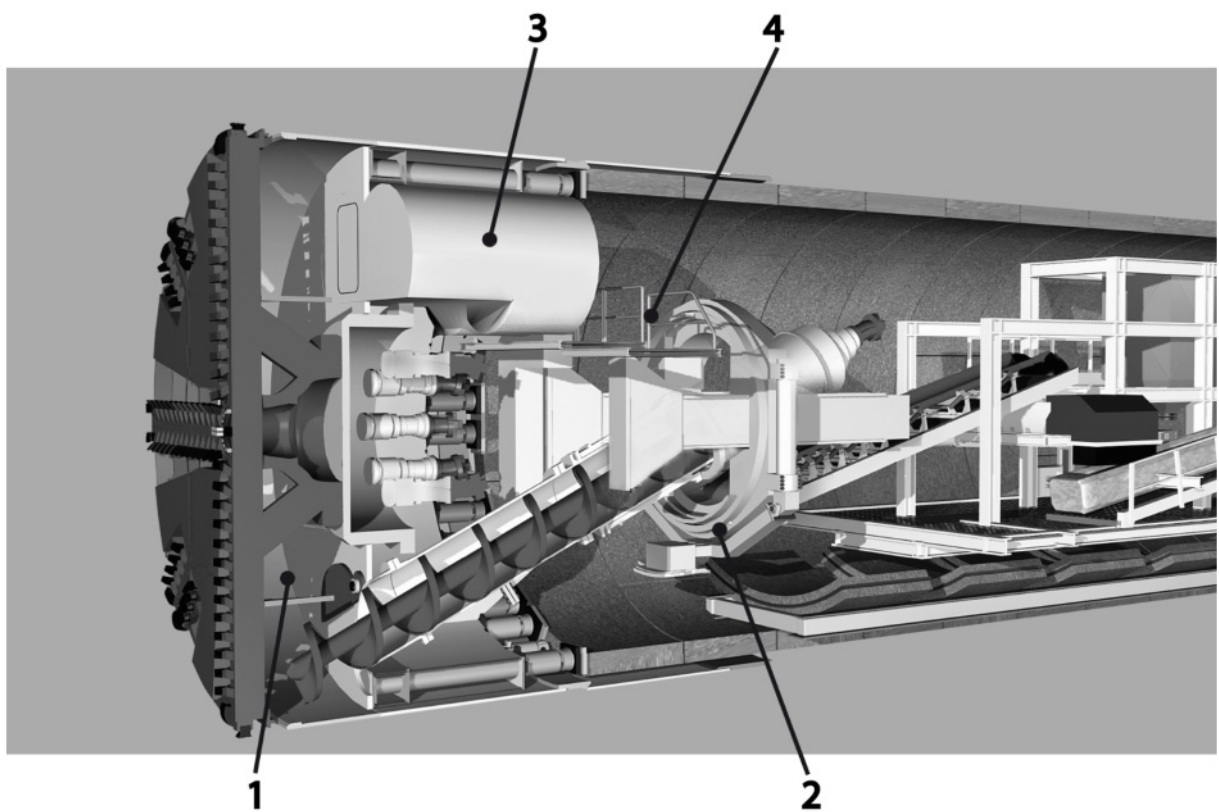

Key

- 1 excavation chamber
- 2 lining erection equipment
- 3 air lock
- 4 working area

Figure A.2 — Shielded tunnel boring machine

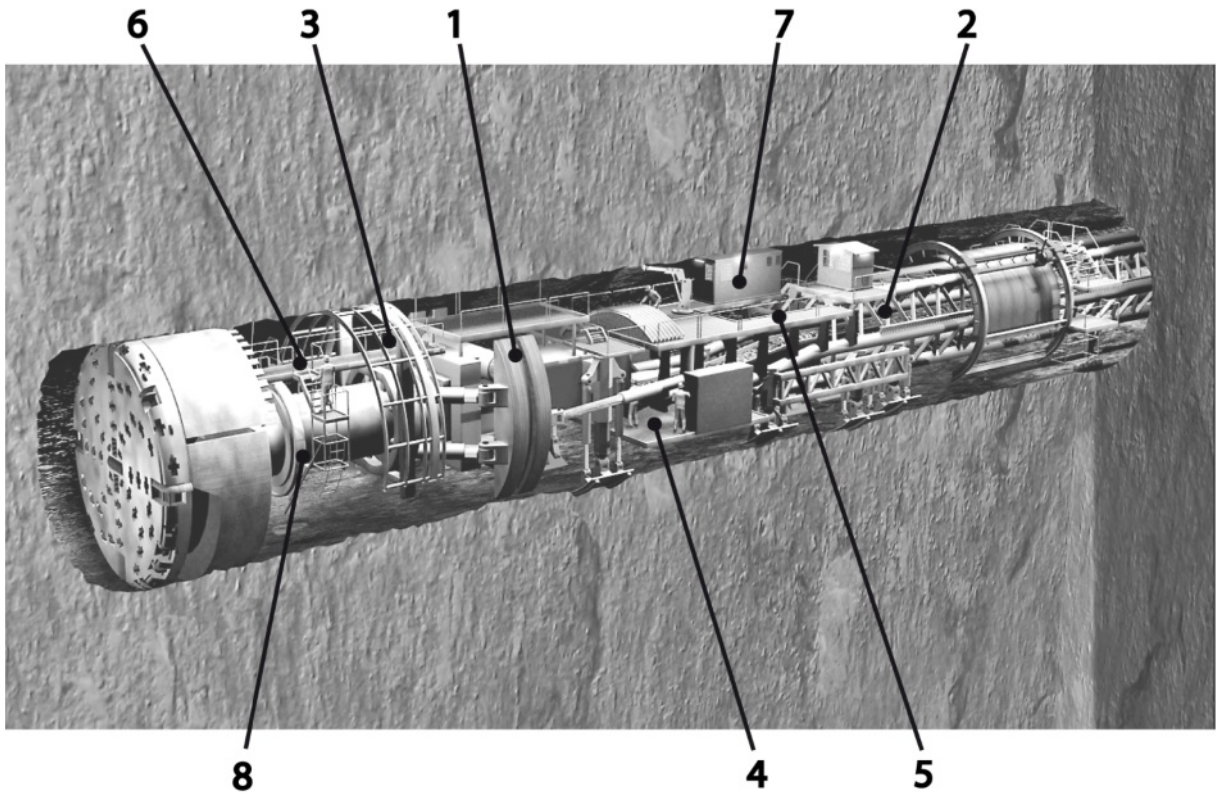

Key

- 1 gripping system
- 2 towed back-up system
- 3 erection device
- 4 control station
- 5 walkway
- 6 working area
- 7 main control station
- 8 rockbolting device

Figure A.3 — Unshielded tunnel boring machine

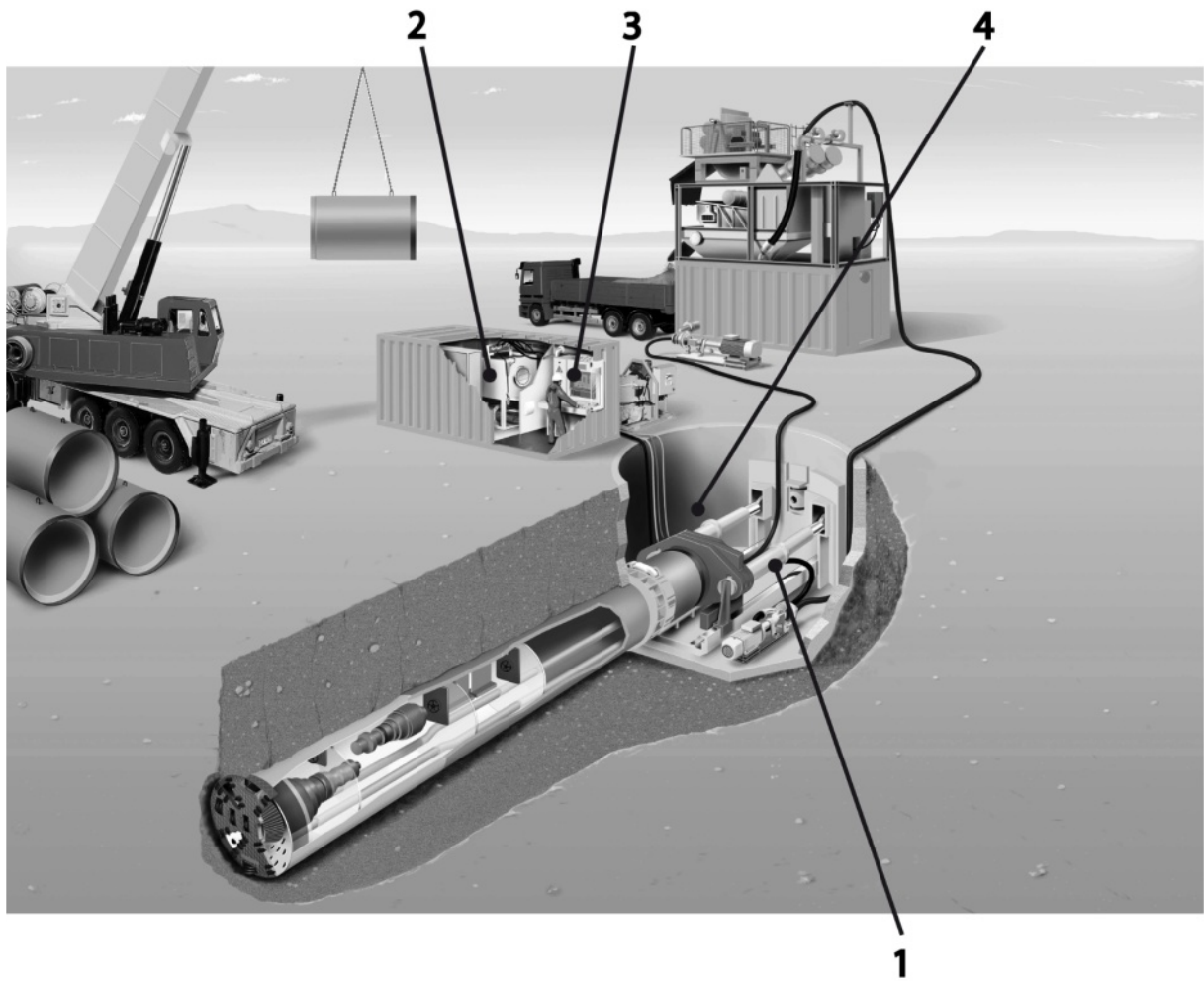

Key

- 1 pipe jacking rig
- 2 stationary backup equipment
- 3 main control station
- 4 working area (shaft)

Figure A.4 — Micro tunnelling machine

Annex B (normative)

Verification of safety requirements and/or protective measures

Safety requirements and/or protective measures of Clauses 5 and 7 of this European Standard shall be fully verified before issuing the declaration of conformity according to the table below. It includes the following types of verification:

- a) design check: the result of which being to establish that the design documents comply with the requirements of this European Standard;
- b) calculation: the results of which being to establish that the requirements of this European Standard have been met;
- c) visual verification: the result of which only being to establish that something is present (e.g. a guard, a marking, a document);
- d) measurement: the result of which shows that the required numerical values have been met (e.g. geometric dimensions, safety distances, resistance of insulation of the electric circuits, noise, vibrations);
- e) functional tests: the result of which shows that the adequate signals intended to be forwarded to the main control system of the complete machine are available and comply with the requirements and with the technical documentation;
- f) special verification: the procedure being given under “remarks” or in the referred clause.

Table B.1 — Verification of safety requirements and/or protective measures

Clause	Design check	Calculation	Visual verification	Measurement	Functional test	Special verification
5.2.1			x			
5.2.2	x		x	x		
5.2.3	x		x			1)
5.2.4, para 1	x		x	x		
5.2.4, para 2	x					
5.2.4, para 3					x	
5.2.4, para 4	x		x			
5.2.4, para 5	x	x			x	
5.2.4, para 6	x		x			
5.2.5.1			x		x	
5.2.5.2, para 1			x			
5.2.5.2, para 2	x				x	
5.2.5.2, para 3				x	x	
5.2.5.2, para 4	x		x		x	
5.2.5.2, para 5				x		
5.2.6.1, para 1	x		x			

5.2.6.1, para 2	x		x			
5.2.6.2, para 1	x				x	
5.2.6.2, para 2	x				x	
5.2.6.2, para 3	x				x	
5.2.7	x	x				2)
5.2.8.	x					3)
5.2.9	x					3)
5.2.10.1	x		x			
5.2.10.2, para 1				x		
5.2.10.2, para 2				x		
5.2.10.2, para 3				x		
5.2.10.2, para 4				x		
5.2.10.2, para 5			x	x		
5.2.10.2, para 6			x			
5.2.10.3				x		
5.2.11.1	x		x			
5.2.11.2	x		x			2)
5.2.11.3	x		x			
5.2.11.4	x		x			
5.2.12	x		x			
5.3.1	x			x		
5.3.2			x			
5.3.3			x		x	
5.4.1			x			
5.4.2			x			3)
5.4.3					x	3)
5.4.4, para 2	x				x	
5.4.4, para 3	x				x	
5.4.4, para 4	x				x	
5.4.4, para 5					x	
5.4.4, para 6	x		x			
5.4.4, para 7			x			
5.4.4, para 8			x			
5.4.4, para 9	x	x	x	x	x	
5.4.4, para 10	x		x			
5.4.4, para 11			x			
5.4.5					x	
5.5.1	x				x	3)
5.5.2			x		x	
5.5.3	x				x	3)

5.5.4.1					x	
5.5.4.2					x	
5.5.4.3	x				x	3)
5.5.5.1				x	x	3)
5.5.5.2				x	x	3)
5.5.5.3			x			
5.5.6	x				x	3)
5.6, para 1		x				
5.6, para 2		x				
5.6, para 3			x			
5.6, para 4					x	
5.6, para 5	x				x	
5.6, para 6	x	x				
5.6, para 7	x	x				
5.7			x			
5.8.1	x					
5.8.2.1	x					
5.8.2.2	x					
5.8.3	x					
5.8.4.1		x				
5.8.4.2	x		x		x	
5.8.4.3	x		x		x	3)
5.8.5			x			
5.9.2	x					
5.9.3				x		3)
5.10.1	x					3)
5.10.2, para 1	x				x	3)
5.10.2, para 3	x				x	3)
5.10.2, para 4					x	
5.10.2, para 5					x	
5.10.3	x		x			
5.10.4			x			
5.10.5				x	x	
5.10.6			x			3)
5.10.7				x		
5.10.8				x	x	
5.10.9	x			x	x	
5.10.10			x		x	
5.11	x					3)

5.12.1	x		x	x	x	3)
5.12.2	x		x			
5.12.3			x			3)
5.12.4	x				x	
5.13			x			
5.14	x		x			
5.15	x					
5.16.1			x			
5.16.2			x			
5.17.1	x		x			
5.17.2, para 1				x		
5.17.2, para 2	x					
5.17.2, para 3					x	
7.2.1			x			3)
7.2.2			x			
7.2.3.			x			3)
7.2.4			x			
7.3.1			x			
7.3.2			x			
7.3.3			x			
7.4			x			

¹⁾ Verification by reference to hose manufacturers documents.

²⁾ The intended use of the machinery shall be agreed between the manufacturer and the user taking into account information on predicted ground conditions provided by the user.

³⁾ Verification by reference to standard which is mentioned in the corresponding Clause.

Annex C (normative)

Noise test code

C.1 Scope

Noise emission characteristics include emission sound pressure levels at workstations and the sound power level. The determination of those quantities is necessary for:

- manufacturers to declare the noise emitted;
- purposes of noise control at the source at the design stage.

Realistic noise emissions can only be obtained during operation of tunnelling machinery inside a tunnel under the conditions of intended use by the manufacturer. Tunnel conditions do not allow the noise emission to be measured using the existing measurement standards. Consequently noise emission values obtained using this noise test code cannot be used for the purpose of comparing tunnelling machinery.

Tunnelling machinery covered by this standard are very large machines (even the smallest ones have a dimension of at least 10 m).

Therefore instead of determining the sound power level, sound pressure levels around the machine at head height 1,6 m above the working platforms should be measured. However in practice such measurements are not possible because the tunnelling machinery is in the tunnel.

NOTE Because of the above limitations and those in C.2, it cannot be considered that this noise test code allows ESHR 1.7.4.2 u of the Machinery Directive to be fulfilled. However, it is the best possible approach that could be done considering the very complex situation of tunnelling machinery regarding noise and the present knowledge in noise emission metrology.

The noise emission values of machinery shall be documented by the noise declaration in the instruction handbook (see 7.2.1).

C.2 A-weighted emission sound pressure levels at working areas

A-weighted emission sound pressure levels shall be determined in accordance with EN ISO 11202 with the following reservations.

In the case of tunnelling machinery it is not possible with the current state of the art to correct the A-weighted sound pressure levels measured at the operating position for environmental influences for measurements in real tunnel conditions. Therefore at this time for measurements in real tunnel conditions, EN ISO 11202 shall be used without an environmental correction and it shall be considered that the accuracy grade attained is grade 3.

The working areas at which to measure the sound pressure levels shall be:

- main control station;
- remote control stations as defined by the manufacturer;
- other working areas related to lining erection equipment, erecting device, rock bolting device.

For measurements in cabins, windows and doors shall be closed.

The measurement time at each measurement position shall be 10 minutes.

NOTE The values obtained are called “emission values”, but they do not describe the noise emission of the tunnelling machine taken alone. They describe the noise emission situation at working areas in the tunnel where the machine operates.

C.3 Installation and operating conditions

Measurement shall be made during the first use of the tunnelling machinery once the whole machinery is installed in the tunnel.

The operating conditions shall be those during the first use of the tunnelling machinery once the whole machinery is installed in the tunnel.

C.4 Information to be recorded and reported

The information to be recorded and reported shall be as follows:

- type of machinery and identification;
- ground conditions;
- tunnel dimensions;
- operating conditions;
- main operation parameters;
- A-weighted emission sound pressure levels at the working areas and associated uncertainty (see C.5);
- place, date of measurement, person responsible for measurement.

C.5 Declaration noise emission values

Noise emission values for tunnelling machinery shall be declared as dual-number noise emission values according to EN ISO 4871.

The following data shall be provided:

- the values of the A-weighted emission sound pressure levels at workstations determined according to C.2;
- the associated measurement uncertainty;
- details about the measurement positions;
- details about the operating conditions of the machine during noise measurements;
- description of the tunnel where the machine operates.

At this point in time there is no detailed knowledge of the measurement uncertainties. Till more experience has been gained, it shall be assumed that the uncertainty related to the measurement of A-weighted emission sound pressure level, K_{pA} for tunnelling machines is 5 dB.

Annex D (normative)

Minimum requirements for refuge chamber

D.1 General

Where shown necessary by the tunnel project risk assessment, a refuge chamber shall be provided on the tunnelling machinery.

The refuge chamber should improve the chance of survival of persons trapped within the tunnel by fume, gas or smoke until external rescue is achieved.

The number of persons accommodated in the chamber shall be determined from the tunnel project risk assessment.

The number of persons accommodated should include the tunnel crew plus 2 persons. Additional capacity for visitors should be considered.

When designing the access the traffic hazard and safe access for rescue (frontal arrangement) shall be taken into consideration.

The location of the refuge chamber shall be determined from the tunnel project risk assessment.

D.2 Concept and design

The dimensions of the chamber shall be sufficient to provide at least $0,75 \text{ m}^2$ /person of floor area, a minimum head-room of 1,6 m and a minimum volume of $1,5 \text{ m}^3$ /person.

Where shown necessary by the tunnel project risk assessment, a refuge chamber with reduced dimensions may be provided for tunnels of internal diameter 3,5 m or less.

There shall be a window either in the door or in the wall of the chamber adjacent to the door to allow visual contact.

It shall be possible to open the door from inside and outside the chamber.

The location of the chamber shall take account of traffic hazards and the need for sufficient access for stretcher.

Measures shall be taken to prevent the pressure in the chamber exceeding 0.01 bar (gauge).

D.3 Air supply

The chamber shall be provided with a connection point to which an external air supply can be attached.

Instructions for connection of the air supply shall be described in the information for use (see 7.3).

There shall be an emergency breathing supply of 4 h (40 l/min per person assumed breathing rate) duration independent of the external air supply.

NOTE This can be achieved either from compressed air supply or from a self-contained regenerative installation on the tunnelling machinery.

Air filters, silencers and diffusers shall be provided.

A visible and audible warning device shall be fitted outside the chamber to signal the interruption of the external air supply.

Controls shall be fitted in the refuge chamber to adjust the air flow.

D.4 Visual identification

The refuge chamber shall be painted white and have a green reflective band at least 100 mm wide around the midsection.

A flashing light or beacon shall be fitted at a low level on the wall of the refuge chamber on which the door is fitted and the activation of the emergency warning system, see 5.5.5.2 shall also switch on this light.

D.5 Power supply

The refuge chamber shall be provided with its own battery power supply capable of powering the chamber facilities for at least 24 h. These facilities include communication, lighting and flashing lights.

D.6 Interior equipment

Interior equipment shall include:

- a) voice communication;
- b) internal lighting 15 lux minimum at the air supply controls;
- c) seats;
- d) at least 2 m³ storage space for rescue equipment (e.g. stretchers, toilet) and water;
- e) air conditioning;
- f) oxygen cylinder(s) and regenerative scrubbing system;
- g) chemical toilet;
- h) internal gas monitoring;
- i) supply of drinking water.

D.7 Instruction manual

The instruction manual shall contain information about the maximum number of persons, for which the refugee chamber is designed.

It shall also contain Information about maintenance, cleaning, air supply, etc.

Annex ZA (informative)

Relationship between this European Standard and the Essential Requirements of EU Directive 2006/42/EC

This European Standard has been prepared under a mandate given to CEN by the European Commission and the European Free Trade Association to provide a means of conforming to Essential Requirements of the New Approach Directive 2006/42/EC on machinery.

Once this standard is cited in the Official Journal of the European Union under that Directive and has been implemented as a national standard in at least one Member State, compliance with the normative clauses of this standard confers, within the limits of the scope of this standard, a presumption of conformity with the relevant Essential Requirements of that Directive, except Essential Requirement 1.7.4.2 of Annex I, and associated EFTA regulations.

WARNING — Other requirements and other EU Directives may be applicable to the product(s) falling within the scope of this standard.

Bibliography

Below are listed standards which have a bearing on the specifications of this European Standard and are not normative references.

- [1] 30 CFR, Code of Federal Regulations
- [2] EN 1005-2:2003+A1:2008, *Safety of machinery - Human physical performance - Part 2: Manual handling of machinery and component parts of machinery*
- [3] EN 1710:2005+A1:2008, *Equipment and components intended for use in potentially explosive atmospheres in underground mines*
- [4] EN ISO 11688-2:2000, *Acoustics - Recommended practice for the design of low-noise machinery and equipment - Part 2: Introduction to the physics of low-noise design (ISO/TR 11688-2:1998)*

British Standards Institution (BSI)

BSI is the national body responsible for preparing British Standards and other standards-related publications, information and services.

BSI is incorporated by Royal Charter. British Standards and other standardization products are published by BSI Standards Limited.

About us

We bring together business, industry, government, consumers, innovators and others to shape their combined experience and expertise into standards-based solutions.

The knowledge embodied in our standards has been carefully assembled in a dependable format and refined through our open consultation process. Organizations of all sizes and across all sectors choose standards to help them achieve their goals.

Information on standards

We can provide you with the knowledge that your organization needs to succeed. Find out more about British Standards by visiting our website at bsigroup.com/standards or contacting our Customer Services team or Knowledge Centre.

Buying standards

You can buy and download PDF versions of BSI publications, including British and adopted European and international standards, through our website at bsigroup.com/shop, where hard copies can also be purchased.

If you need international and foreign standards from other Standards Development Organizations, hard copies can be ordered from our Customer Services team.

Subscriptions

Our range of subscription services are designed to make using standards easier for you. For further information on our subscription products go to bsigroup.com/subscriptions.

With **British Standards Online (BSOL)** you'll have instant access to over 55,000 British and adopted European and international standards from your desktop. It's available 24/7 and is refreshed daily so you'll always be up to date.

You can keep in touch with standards developments and receive substantial discounts on the purchase price of standards, both in single copy and subscription format, by becoming a **BSI Subscribing Member**.

PLUS is an updating service exclusive to BSI Subscribing Members. You will automatically receive the latest hard copy of your standards when they're revised or replaced.

To find out more about becoming a BSI Subscribing Member and the benefits of membership, please visit bsigroup.com/shop.

With a **Multi-User Network Licence (MUNL)** you are able to host standards publications on your intranet. Licences can cover as few or as many users as you wish. With updates supplied as soon as they're available, you can be sure your documentation is current. For further information, email bsmusales@bsigroup.com.

BSI Group Headquarters

389 Chiswick High Road London W4 4AL UK

Revisions

Our British Standards and other publications are updated by amendment or revision.

We continually improve the quality of our products and services to benefit your business. If you find an inaccuracy or ambiguity within a British Standard or other BSI publication please inform the Knowledge Centre.

Copyright

All the data, software and documentation set out in all British Standards and other BSI publications are the property of and copyrighted by BSI, or some person or entity that owns copyright in the information used (such as the international standardization bodies) and has formally licensed such information to BSI for commercial publication and use. Except as permitted under the Copyright, Designs and Patents Act 1988 no extract may be reproduced, stored in a retrieval system or transmitted in any form or by any means – electronic, photocopying, recording or otherwise – without prior written permission from BSI. Details and advice can be obtained from the Copyright & Licensing Department.

Useful Contacts:

Customer Services

Tel: +44 845 086 9001

Email (orders): orders@bsigroup.com

Email (enquiries): cservices@bsigroup.com

Subscriptions

Tel: +44 845 086 9001

Email: subscriptions@bsigroup.com

Knowledge Centre

Tel: +44 20 8996 7004

Email: knowledgecentre@bsigroup.com

Copyright & Licensing

Tel: +44 20 8996 7070

Email: copyright@bsigroup.com



...making excellence a habit.™