

BS EN 16124:2011



BSI Standards Publication

Founding — Low-alloyed ferritic spheroidal graphite cast irons for elevated temperature applications

bsi.

...making excellence a habit.™

National foreword

This British Standard is the UK implementation of EN 16124:2011.

The UK participation in its preparation was entrusted to Technical Committee ISE/111, Steel Castings and Forgings.

A list of organizations represented on this committee can be obtained on request to its secretary.

This publication does not purport to include all the necessary provisions of a contract. Users are responsible for its correct application.

© BSI 2011

ISBN 978 0 580 71354 5

ICS 77.080.10

Compliance with a British Standard cannot confer immunity from legal obligations.

This British Standard was published under the authority of the Standards Policy and Strategy Committee on 31 December 2011.

Amendments issued since publication

Date	Text affected
------	---------------

EUROPEAN STANDARD

EN 16124

NORME EUROPÉENNE

EUROPÄISCHE NORM

November 2011

ICS 77.080.10

English Version

Founding - Low-alloyed ferritic spheroidal graphite cast irons for elevated temperature applications

Fonderie - Fontes ferritiques à graphite sphéroïdal faiblement alliées pour applications à haute température

Gießereiwesen - Niedriglegiertes ferritisches Gusseisen mit Kugelgraphit für Anwendungen bei höheren Temperaturen

This European Standard was approved by CEN on 15 October 2011.

CEN members are bound to comply with the CEN/CENELEC Internal Regulations which stipulate the conditions for giving this European Standard the status of a national standard without any alteration. Up-to-date lists and bibliographical references concerning such national standards may be obtained on application to the CEN-CENELEC Management Centre or to any CEN member.

This European Standard exists in three official versions (English, French, German). A version in any other language made by translation under the responsibility of a CEN member into its own language and notified to the CEN-CENELEC Management Centre has the same status as the official versions.

CEN members are the national standards bodies of Austria, Belgium, Bulgaria, Croatia, Cyprus, Czech Republic, Denmark, Estonia, Finland, France, Germany, Greece, Hungary, Iceland, Ireland, Italy, Latvia, Lithuania, Luxembourg, Malta, Netherlands, Norway, Poland, Portugal, Romania, Slovakia, Slovenia, Spain, Sweden, Switzerland and United Kingdom.



EUROPEAN COMMITTEE FOR STANDARDIZATION
COMITÉ EUROPÉEN DE NORMALISATION
EUROPÄISCHES KOMITEE FÜR NORMUNG

Management Centre: Avenue Marnix 17, B-1000 Brussels

Contents

Page

Foreword.....	3
Introduction	4
1 Scope	5
2 Normative references	5
3 Terms and definitions	5
4 Designation	6
5 Order information	6
6 Manufacture.....	6
7 Requirements	7
7.1 Chemical composition	7
7.2 Microstructure.....	7
7.3 Mechanical properties.....	8
8 Sampling.....	9
8.1 General.....	9
8.2 Cast samples for tensile testing.....	9
8.3 Samples cut from a casting	11
9 Test methods.....	15
9.1 Chemical analysis.....	15
9.2 Micrographic examination	15
9.3 Tensile test	15
9.4 Hardness test	16
9.5 Specific test.....	16
10 Retests	17
10.1 Need for retests.....	17
10.2 Test validity	17
10.3 Non-conforming test results.....	17
10.4 Heat treatment of samples and castings.....	17
11 Inspection documentation	17
Annex A (informative) Guidance values of mechanical properties for 3 special grades.....	18
Annex B (informative) Properties of low alloyed ferritic spheroidal graphite cast irons at elevated temperatures	19
Annex C (informative) Additional information on general mechanical and physical properties	33
Annex D (informative) Heat treatment	34
Annex E (informative) Nodularity.....	35
Annex F (normative) Sectioning procedure for cast samples.....	36
Bibliography	37

Foreword

This document (EN 16124:2011) has been prepared by Technical Committee CEN/TC 190 "Foundry technology", the secretariat of which is held by DIN.

This European Standard shall be given the status of a national standard, either by publication of an identical text or by endorsement, at the latest by May 2012, and conflicting national standards shall be withdrawn at the latest by May 2012.

Attention is drawn to the possibility that some of the elements of this document may be the subject of patent rights. CEN [and/or CENELEC] shall not be held responsible for identifying any or all such patent rights.

Within its programme of work, Technical Committee CEN/TC 190 requested CEN/TC 190/WG 7 "Spheroidal graphite, silicon molybdenum and austempered ductile iron" to prepare EN 16124.

According to the CEN/CENELEC Internal Regulations, the national standards organizations of the following countries are bound to implement this European Standard: Austria, Belgium, Bulgaria, Croatia, Cyprus, Czech Republic, Denmark, Estonia, Finland, France, Germany, Greece, Hungary, Iceland, Ireland, Italy, Latvia, Lithuania, Luxembourg, Malta, Netherlands, Norway, Poland, Portugal, Romania, Slovakia, Slovenia, Spain, Sweden, Switzerland and the United Kingdom.

Introduction

This European Standard classifies low-alloyed ferritic spheroidal graphite cast irons, principally used for their heat and oxidation resistance properties.

NOTE Ferritic spheroidal graphite cast irons alloyed with silicon and molybdenum is also known as SiMo cast irons.

Due to the ferritic structure and the silicon and molybdenum content, these cast irons allow producing castings which are resistant to distortion and oxidation at high temperatures.

Nine grades of low-alloyed ferritic spheroidal graphite cast iron are defined by their silicon and molybdenum content.

Typical applications for the first three grades are medium to heavy castings like turbine housings and compressor parts. The other six grades are mainly applied for exhaust manifolds and turbocharger parts in automotive applications.

The mechanical properties of the material can be evaluated on machined test pieces prepared from cast samples or samples cut from a casting.

Additional information on technical properties for low-alloyed ferritic spheroidal graphite cast iron is given in Annex B and Annex C.

1 Scope

This European Standard defines the grades and the corresponding requirements for low-alloyed ferritic spheroidal graphite cast irons for elevated temperature applications.

These requirements are specified in terms of

- chemical composition: as given for each of the grades,
- graphite form and matrix structure: spheroidal graphite in a predominantly ferritic matrix,
- mechanical properties measured on machined test pieces prepared from cast samples.

This European Standard does not cover technical delivery conditions for iron castings, see EN 1559-1 [1] and EN 1559-3 [2].

2 Normative references

The following referenced documents are indispensable for the application of this document. For dated references, only the edition cited applies. For undated references, the latest edition of the referenced document (including any amendments) applies.

EN 10204, *Metallic products — Types of inspection documents*

EN ISO 945-1:2008, *Microstructure of cast irons — Part 1: Graphite classification by visual analysis (ISO 945-1:2008)*

EN ISO 6506-1, *Metallic materials — Brinell hardness test — Part 1: Test method (ISO 6506-1)*

EN ISO 6892-1, *Metallic materials — Tensile testing — Part 1: Method of test at room temperature (ISO 6892-1)*

3 Terms and definitions

For the purposes of this document, the following terms and definitions apply.

3.1

low alloyed ferritic spheroidal graphite cast iron

cast iron material with carbon mainly present in the form of spheroidal graphite particles, alloyed with silicon in order to produce a predominantly ferritic matrix and alloyed with molybdenum to improve mechanical properties at elevated temperatures

3.2

graphite spheroidizing treatment

operation that brings the liquid iron into contact with a substance to produce graphite in the predominantly spheroidal (nodular) form during solidification

NOTE This operation is often followed by a second one called inoculation.

3.3

cast sample

quantity of material cast to represent the cast material, including separately cast sample, side by side cast sample and cast-on sample

3.4

separately cast sample

sample cast in a separate sand mould under representative manufacturing conditions and material grade

- 3.5**
side-by-side cast sample
sample cast in the mould alongside the casting, with a joint running system
- 3.6**
cast-on sample
sample attached directly to the casting
- 3.7**
relevant wall thickness
wall thickness representative of the casting, defined for the determination of the size of the cast samples to which the mechanical properties apply

4 Designation

The material shall be designated either by symbol or by number as given in Table 1.

NOTE The designation system is in accordance with EN 1560 [3].

In the case of samples cut from the casting, the letter C is added at the end of the designation by symbol.

5 Order information

The following information shall be supplied by the purchaser:

- a) the number of this European Standard;
- b) the designation of the material;
- c) the relevant wall thickness of the casting;
- d) any special requirements.

All requirements shall be agreed between the manufacturer and the purchaser by the time of acceptance of the order, e.g. technical delivery conditions according to EN 1559-1 and EN 1559-3.

6 Manufacture

Unless otherwise specified by the purchaser, the method of manufacture of low-alloyed ferritic spheroidal graphite cast irons and any heat treatment required to obtain the specified mechanical properties and microstructure shall be left to the discretion of the manufacturer.

The manufacturer shall ensure that the requirements defined in this European Standard are met for the material grade specified in the order.

All agreements between the manufacturer and the purchaser shall be made by the time of acceptance of the order.

7 Requirements

7.1 Chemical composition

The silicon and molybdenum content of low-alloyed ferritic spheroidal graphite cast iron grades shall be in accordance with Table 1.

Unless otherwise agreed, the content of other elements shall be left to the discretion of the manufacturer.

If the presence of any element specified in Table 1 is required to be outside the limits indicated, or if any other alloying elements are required, their contents shall be agreed between the manufacturer and the purchaser and specified in the order.

Table 1 — Chemical composition

Material designation		Silicon % (mass fraction)	Molybdenum % (mass fraction)
Symbol	Number		
EN-GJS-SiMo25-5	5.3111	2,3 to 2,7	0,4 to 0,6
EN-GJS-SiMo30-7	5.3112	2,8 to 3,2	0,6 to 0,8
EN-GJS-SiMo35-5	5.3113	3,3 to 3,7	0,4 to 0,6
EN-GJS-SiMo40-6	5.3114	3,8 to 4,2	0,5 to 0,7
EN-GJS-SiMo40-10	5.3115		0,8 to 1,1
EN-GJS-SiMo45-6	5.3116	4,3 to 4,7	0,5 to 0,7
EN-GJS-SiMo45-10	5.3117		0,8 to 1,1
EN-GJS-SiMo50-6	5.3118	4,8 to 5,2	0,5 to 0,7
EN-GJS-SiMo50-10	5.3119		0,8 to 1,1

7.2 Microstructure

7.2.1 Graphite structure

The graphite structure shall be mainly of form V and VI in accordance with EN ISO 945-1. A more precise definition may be agreed upon by the time of acceptance of the order.

NOTE Annex E gives more information on nodularity.

7.2.2 Matrix structure

The matrix structure shall consist of minimum 85 % ferrite, the balance consisting of pearlite and carbides.

Carbides can be present to a maximum of 5 %.

Other limits may be agreed upon by the time of acceptance of the order.

7.3 Mechanical properties

7.3.1 Tensile properties

The mechanical properties of the grades of cast irons obtained from cast samples with a thickness equal or less than 30 mm shall be in accordance with Table 2.

Other requirements, such as the mechanical properties to be met on samples with a thickness > 30 mm or at specified locations on the castings, shall be agreed between the manufacturer and the purchaser and specified in the order. If applicable, the position of the cast-on sample or the specified location on the casting shall be agreed between the manufacturer and the purchaser and specified in the order.

NOTE Tensile testing requires sound test pieces in order to guarantee pure uni-axial stress during the test.

7.3.2 Hardness

Guidance values for the Brinell hardness range of the material grades are given in Table 2 and are applicable to the casting.

Table 2 — Mechanical properties measured at ambient temperature on test pieces machined from cast samples of low-alloyed ferritic spheroidal graphite cast irons

Material designation		0,2 % proof strength	Tensile strength	Elongation	Brinell hardness range ^a
Symbol	Number	$R_{p0,2}$ MPa min.	R_m MPa min.	A % min.	HBW
EN-GJS-SiMo25-5	5.3111	Guidance values are given in Annex A			
EN-GJS-SiMo30-7	5.3112				
EN-GJS-SiMo35-5	5.3113				
EN-GJS-SiMo40-6	5.3114	380	480	8	190 to 240
EN-GJS-SiMo40-10	5.3115	400	510	6	190 to 240
EN-GJS-SiMo45-6	5.3116	420	520	7	200 to 250
EN-GJS-SiMo45-10	5.3117	460	550	5	200 to 250
EN-GJS-SiMo50-6	5.3118	480	580	4	210 to 260
EN-GJS-SiMo50-10	5.3119	500	600	3	210 to 260

^a Values for information, measured on the casting.

8 Sampling

8.1 General

Samples shall be made from the same material as that used to produce the casting(s) which they represent.

Several types of samples (separately cast samples, cast-on samples, side-by-side cast samples, samples cut from a casting) can be used, depending on the mass and wall thickness of the casting.

When relevant, the type of sample should be agreed between the manufacturer and the purchaser. Unless otherwise agreed the choice of the option is left to the discretion of the manufacturer.

When the mass of the casting exceeds 2 000 kg and its thickness exceeds 60 mm, cast-on samples should preferably be used; the dimensions and the location of the cast-on sample shall be agreed between the manufacturer and the purchaser by the time of acceptance of the order.

If the spheroidizing treatment is carried out in the mould (in-mould process), the separately cast sample should be avoided.

All samples shall be adequately marked to guarantee full traceability to the castings which they represent.

The samples shall be subject to the same heat treatment, as that of the castings they represent, if any.

Tensile test pieces shall be finally machined from the samples after the heat treatment.

The samples for chemical analysis shall be cast in a manner which ensures that the accurate chemical composition can be determined.

Due to post inoculation treatments, slight differences regarding the silicon content may be admitted.

8.2 Cast samples for tensile testing

8.2.1 Size of cast samples

The size of the sample shall be in correspondence with the relevant wall thickness of the casting as shown in Table 3.

If other sizes are used, this shall be agreed between the manufacturer and purchaser.

Table 3 — Types and size of cast sample and size of tensile test pieces in relation to relevant wall thickness of the casting

Relevant wall thickness t mm	Type of sample				Preferred diameter of tensile test piece ^a d mm
	Option 1 U-shaped (see Figure 1)	Option 2 Y-shaped (see Figure 2)	Option 3 round bar (see Figure 3)	Cast-on sample (see Figure 4)	
$t \leq 12,5$	—	I	Types b, c	A	7 (Option 3: 14 mm)
$12,5 < t \leq 30$	—	II	Types a, b, c	B	14
$30 < t \leq 60$	b	III	—	C	14
$60 < t \leq 200$	—	IV	—	D	14

^a Other diameters, in accordance with Figure 5, may be agreed between the manufacturer and the purchaser.

^b The cooling rate of this cast sample corresponds to that of a 40 mm thick wall.

8.2.2 Frequency and number of tests

Samples, representative of the material, shall be produced at a frequency in accordance with the process quality assurance procedure adopted by the manufacturer or as agreed with the purchaser.

In the absence of either a process quality assurance procedure or any agreement between the manufacturer and the purchaser, a minimum of one cast sample for the tensile test shall be produced to confirm the material grade, at a frequency to be agreed between the manufacturer and the purchaser.

8.2.3 Separately cast samples

The samples shall be cast separately in sand moulds and under representative manufacturing conditions.

The moulds used to cast the separately cast samples shall have comparable thermal behaviour to the moulding material used to cast the castings.

The samples shall meet the requirements of either Figures 1, 2 or 3.

The samples shall be removed from the mould at a temperature similar to that of the castings.

8.2.4 Side-by-side cast samples

Side-by-side cast samples are representative of the castings concurrently cast and also of all other castings of a similar relevant wall thickness from the same test unit.

When mechanical properties are required for a series of castings belonging to the same test unit, the side-by-side cast sample(s) shall be produced in the last mould(s) poured.

The samples shall meet the requirements of either Figures 1, 2 or 3.

8.2.5 Cast-on samples

Cast-on samples are representative of the castings to which they are attached and also of all other castings of a similar relevant wall thickness from the same test unit.

When mechanical properties are required for a series of castings belonging to the same test unit, the cast-on sample(s) shall be produced in the last mould(s) poured.

The sample shall have a general shape as indicated in Figure 4 and the dimensions shown therein.

The location of the cast-on sample shall be agreed between the manufacturer and the purchaser by the time of acceptance of the order, taking into account the shape of the casting and the running system, in order to avoid any unfavourable effect on the properties of the adjacent material.

8.2.6 Test pieces machined from cast samples

The tensile test piece shown in Figure 5 shall be machined from a sample shown in Figure 3 or from the hatched part of Figures 1, 2 or 4.

The sectioning procedure for cast samples according to Figure 2 and 4 shall be in accordance with Annex F.

Unless otherwise agreed, the preferred diameter for the test piece shall be used.

8.3 Samples cut from a casting

In addition to the requirements of the material, the manufacturer and the purchaser may agree on the properties required at stated locations in the casting. These properties shall be determined by testing test pieces machined from samples cut from the casting at these stated locations.

The manufacturer and the purchaser shall agree on the dimensions of these test pieces.

In the absence of any directions by the purchaser, the manufacturer may choose the locations from which to cut the samples and the dimensions of the test pieces.

The centreline of the test piece should be located at a point half way between the surface and the centre.

NOTE 1 When the zone of last solidification in the casting is included in the test piece diameter, the minimum elongation value may not be obtained.

NOTE 2 In the case of large individual castings trepanned samples may be taken at agreed positions in the casting which are to be stated.

Dimensions in millimetres

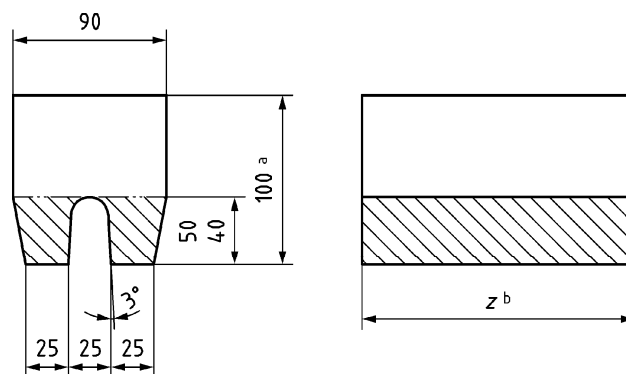

The thickness of the sand mould surrounding the samples shall be at least 40 mm.

Key

- ^a For information only.
- ^b The length z shall be chosen to allow a test piece of dimensions shown in Figure 5 to be machined from the sample.

Figure 1 — Separately cast or side-by-side cast sample — Option 1: U-shaped sample

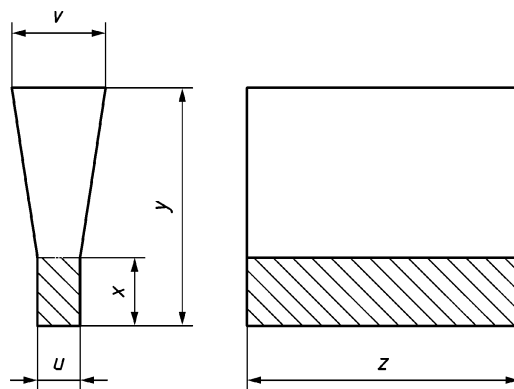

Dimensions in millimetres

Dimension	Type			
	I	II	III	IV
u	12,5	25	50	75
v	40	55	100	125
x	25	40	50	65
y^a	135	140	150	175
z^b	A function of the test piece length			
^a For information only. ^b The length z shall be chosen to allow a test piece of dimensions shown in Figure 5 to be machined from the sample.				

The thickness of the sand mould surrounding the samples shall be at least:

- 40 mm for types I and II;
- 80 mm for types III and IV.

Figure 2 — Separately cast or side by side cast samples — Option 2: Y-shaped sample

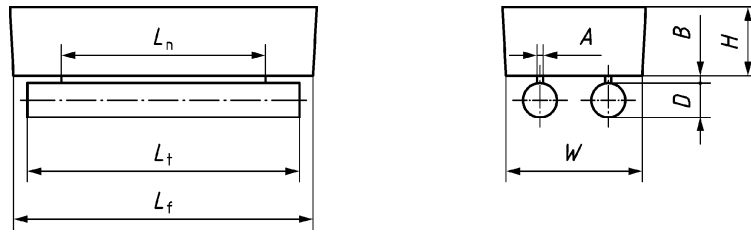

Type a

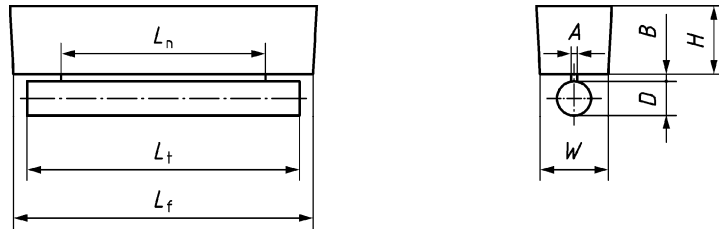

Type b

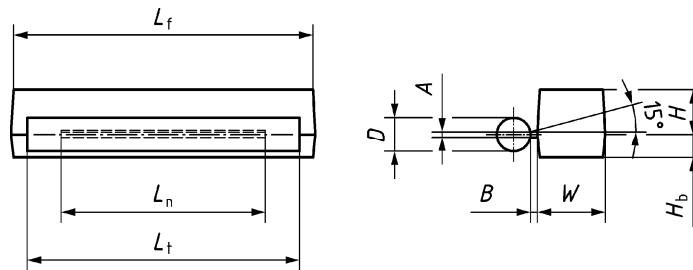

Type c

Dimensions in millimetres

Type	<i>A</i>	<i>B</i>	<i>D</i>	<i>H</i>	<i>H_b</i>	<i>L_f</i>	<i>L_n</i>	<i>L_t</i>	<i>W</i>
a	4,5	5,5	25	50	—	$L_t + 20$	$L_t - 50$	a	100
b	4,5	5,5	25	50	—	$L_t + 20$	$L_t - 50$		50
c	4,0	5,0	25	35	15	$L_t + 20$	$L_t - 50$		50

^a L_t shall be chosen to allow a test piece of dimensions shown in Figure 5 to be machined from the sample.

The thickness of the sand mould surrounding the samples shall be at least 40 mm.

Figure 3 — Separately cast or side by side cast samples — Option 3: round bar-shaped sample

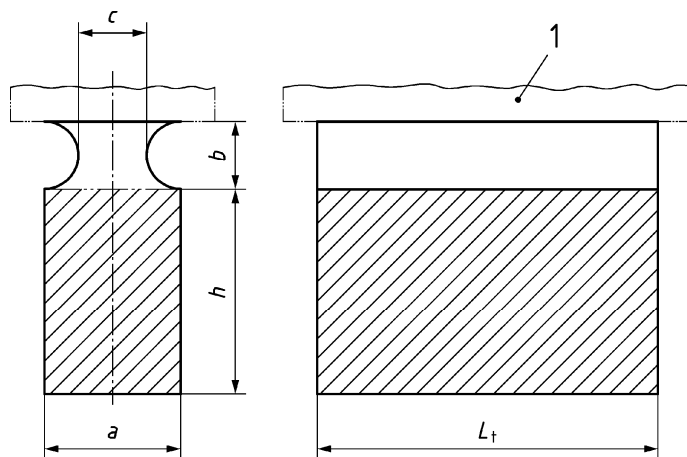

Dimensions in millimetres

Type	Relevant wall thickness of castings t	a	b max	c min	h	L_t
A	$t \leq 12,5$	15	11	7,5	20 to 30	a
B	$12,5 < t \leq 30$	25	19	12,5	30 to 40	
C	$30 < t \leq 60$	40	30	20	40 to 65	
D	$60 < t \leq 100$	70	52,5	35	65 to 105	

^a L_t shall be chosen to allow a test piece of a dimension shown in Figure 5 to be machined from the sample.

Key

1 casting

The thickness of the sand mould surrounding the samples shall be at least:

- 40 mm for types A and B;
- 80 mm for types C and D.

If smaller dimensions are agreed, the followings relationships apply:

$$b = 0,75 \times a$$

$$c = 0,5 \times a$$

Figure 4 — Cast-on samples

9 Test methods

9.1 Chemical analysis

The methods used to determine the chemical composition of the material shall be in accordance with validated procedures. Any requirement for traceability shall be agreed between the manufacturer and the purchaser by the time of acceptance of the order. The chemical analysis shall be carried out on a test sample made from the same melt as the castings the sample represents.

NOTE Optical emission spectrometry and X-ray fluorescence techniques are acceptable methods of analysis.

9.2 Micrographic examination

Graphite and matrix structure shall be confirmed by metallographic examination.

Non-destructive methods can also give information regarding the graphite structure.

In case of dispute, the results of the microscopic examination shall prevail.

9.3 Tensile test

The tensile test shall be carried out in accordance with EN ISO 6892-1.

The preferred test piece diameter is 14 mm but, either for technical reasons or for test pieces machined from samples cut from the casting, it is permitted to use a test piece of different diameter (see Figure 5).

In all cases, the original gauge length of the test piece shall conform to Equation (1):

$$L_o = 5,65 \times \sqrt{S_o} = 5 \times d \quad (1)$$

where

L_o is the original gauge length;

S_o is the original cross-section area of the test piece;

d is the diameter of the test piece along the gauge length.

If Equation (1) for L_o is not applicable, then an agreement shall be made between the manufacturer and the purchaser on the dimensions of the test piece to be made. A test piece with a different gauge length may be agreed upon between the manufacturer and the purchaser.

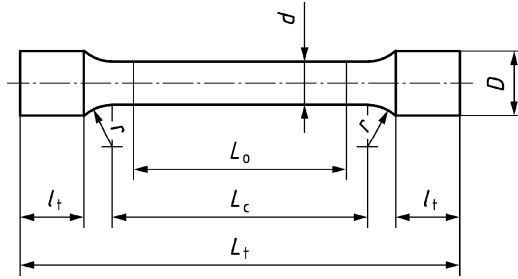

Dimensions in millimetres

d	L_0	L_c min.
5	25	30
7	35	42
10	50	60
14 ^a	70	84
20	100	120

^a Preferred dimension for 25 mm cast sample diameter

where

- L_0 is the original gauge length, i.e. $L_0 = 5 \times d$;
- d is the diameter of the test piece along the gauge length;
- L_c is the parallel length; $L_c > L_0$ (in principle, $L_c - L_0 \geq d$);
- L_t is the total length of the test piece, which depends on L_c ;
- r is the transition radius, which shall be at least 4 mm.

NOTE The method of gripping the ends of the test pieces, together with their length l_t , may be agreed between the manufacturer and the purchaser.

Figure 5 — Tensile test piece

9.4 Hardness test

The hardness shall be determined as Brinell hardness in accordance with EN ISO 6506-1.

Alternative hardness tests and the corresponding required hardness values may also be agreed.

The test shall be carried out on the test pieces or at one or several points on the castings after preparation of the testing area in accordance with the agreement between the manufacturer and the purchaser.

If the measurement locations are not the subject of an agreement, they shall be chosen by the manufacturer.

If it is not possible to carry out the hardness test on the casting, then by agreement between the manufacturer and the purchaser, the hardness test may be carried out on a knob cast-on to the casting.

9.5 Specific test

If specific tests e.g. behaviour at elevated temperature are required this has to be agreed upon by the time of acceptance of the order.

10 Retests

10.1 Need for retests

Retests shall be carried out if a test is not valid.

Retests are permitted to be carried out if a test result does not meet the mechanical property requirements for the specified grade.

10.2 Test validity

A test is not valid if there is

- a) a faulty mounting of the test piece or defective operation of the test machine,
- b) a defective test piece because of incorrect pouring or incorrect machining,
- c) a fracture of the tensile test piece outside the gauge length,
- d) a casting defect in the test piece, evident after fracture.

In the above cases, a new test piece shall be taken from the same cast sample or from a duplicate sample cast at the same time to replace those invalid test results.

10.3 Non-conforming test results

If any test gives results which do not conform to the specified requirements, for reasons other than those given in 10.2, the manufacturer shall have the option to conduct retests.

If the manufacturer conducts retests, two retests shall be carried out for each failed test.

If both retests give results that meet the specified requirements, the material shall be deemed to conform to this European Standard.

If one or both retests give results that fail to meet the specified requirements, the material shall be deemed not to conform to this European Standard.

10.4 Heat treatment of samples and castings

Unless otherwise specified, a heat treatment may be carried out in the case of castings in the as-cast condition with mechanical properties not conforming to this European Standard.

In the case of castings which have undergone a heat treatment and for which the test results are not valid or not satisfactory, the manufacturer shall be permitted to re-heat treat the castings and the representative samples. In this event, the samples shall receive the same number of heat treatments as the castings.

If the results of the tests carried out on the test pieces machined from the re-heat treated samples are satisfactory, then the re-heat treated castings shall be regarded as conforming to the specified requirements of this European Standard.

The number of re-heat treatment cycles shall not exceed two.

11 Inspection documentation

When requested by the purchaser and agreed with the manufacturer, the manufacturer shall issue for the products the appropriate inspection documentation according to EN 10204.

Annex A (informative)

Guidance values of mechanical properties for 3 special grades

A.1 General

Due to limited data available for the grades shown in Table A.1, only guidance values are given for mechanical properties.

These grades are normally not applied for thinner walled castings, as due to the low silicon content, a high amount of pearlite might appear in the matrix structure.

**Table A.1 — Guidance values for mechanical properties
for test pieces machined from cast samples at ambient temperature**

Material designation		Relevant wall thickness mm	0,2 % proof strength	Tensile strength	Elongation	Brinell Hardness range ^a HBW
Symbol	Number		$R_{p0,2}$ MPa min.	R_m MPa min.	A % min.	
EN-GJS-SiMo25-5	5.3111	$30 < t \leq 60$	260	420	12	140 to 210
		$60 < t \leq 200$	250	400	12	130 to 200
EN-GJS-SiMo30-7	5.3112	$30 < t \leq 60$	310	440	10	150 to 220
		$60 < t \leq 200$	300	420	10	140 to 210
EN-GJS-SiMo35-5	5.3113	$30 < t \leq 60$	330	440	8	160 to 230
		$60 < t \leq 200$	320	440	8	150 to 220

^a Values for information, measured on the casting.

Annex B (informative)

Properties of low alloyed ferritic spheroidal graphite cast irons at elevated temperatures

B.1 General

This informative Annex applies to low alloyed ferritic spheroidal graphite cast iron grades, as specified in this European Standard. It gives guidance regarding the mechanical properties of these materials at elevated temperatures.

These materials are produced in a range of compositions and may undergo different kinds of heat treatments, thus the actual specific mechanical properties values are ranging within a wide scatter. During thermal stress, microstructural changes and precipitations may occur which also change the properties [4].

B.2 Physical and mechanical properties

Increasing the silicon content at 4 % raises the AC_1 temperature (transition from ferrite to austenite) to 815 °C, and at 5 % the AC_1 is above 870 °C.

Thus, the matrix structure remains mainly ferritic as far as the temperature of use remains below AC_1 temperature.

Table B.1 illustrates the effect of temperature on the Coefficient of Thermal Expansion (CTE) for several irons [5].

There is no significant effect of the silicon and molybdenum contents on the CTE, which remains around $13,5 \times 10^{-6}/K$.

Figure B.1 shows typical values for temperature dependence of tensile strength of ferritic and austenitic cast iron grades and two cast steel grades. In the case of cast steels and austenitic cast irons, the tensile strength decreases at a constant rate when the temperature increases [4].

For the ferritic spheroidal graphite irons, ductility is restored when temperature exceeds 425 °C, as they show a rapid decrease of tensile resistance over 400 °C.

Alloying with 0,4 % to 1 % Molybdenum generates interdendritic carbides of the Mo_2C type, which remain even through annealing and use of the part. These carbides provide adequate elevated-temperature strength resistance (and creep resistance, see the corresponding paragraph). Higher molybdenum additions tend to reduce toughness and ductility at room temperature.

Silicon and molybdenum additions both increase tensile strength (by about 100 MPa, for 5 % silicon and 1 % molybdenum) and shift the strength decrease toward 500 °C.

Figure B.2 confirms the temperature dependence of tensile strength and 0,2 % proof strength (temperature range 0 °C to 800 °C), in the case of a 5 % silicon and 1 % molybdenum spheroidal graphite cast irons [6].

Figure B.3 shows that increasing the silicon content in spheroidal graphite cast iron raises the tensile strength, the 0,2 % proof strength and the hardness but reduces the elongation [7].

Table B.1 — Average thermal expansion coefficient of ferritic spheroidal graphite cast iron

Composition (mass fraction) %				Average thermal expansion coefficient $10^{-6}/K$ between 20 °C and					
C	Si	Mn	Mo	100 °C	200 °C	300 °C	540 °C	760 °C	815 °C
3,78	2,16	0,50	—	—	—	—	13,0	13,9	—
3,78	2,28	0,49	0,95	—	—	—	12,1	13,3	—
3,39	3,59	0,38	—	9,89	11,83	12,41	—	—	12,96
3,79	4,00	0,37	—	9,89	11,83	12,81	—	—	14,16
3,34	4,02	0,36	1,97 ^a	—	—	—	12,2	—	13,9
3,45	4,03	0,39	—	8,33	11,68	12,87	—	—	13,30
3,36	4,06	0,36	1,98	—	—	—	12,9	—	14,3
3,79	4,12	0,38	—	10,67	12,66	13,42	—	—	13,55
3,07	4,15	0,34	—	—	—	—	12,2	—	13,9
3,05	4,18	0,35	0,98	—	—	—	12,1	—	13,3
3,06	4,21	0,34	4,09	—	—	—	11,9	—	13,3
3,05	4,23	0,34	2,04	—	—	—	12,1	—	13,3

^a Additionally 1,05 % Al.

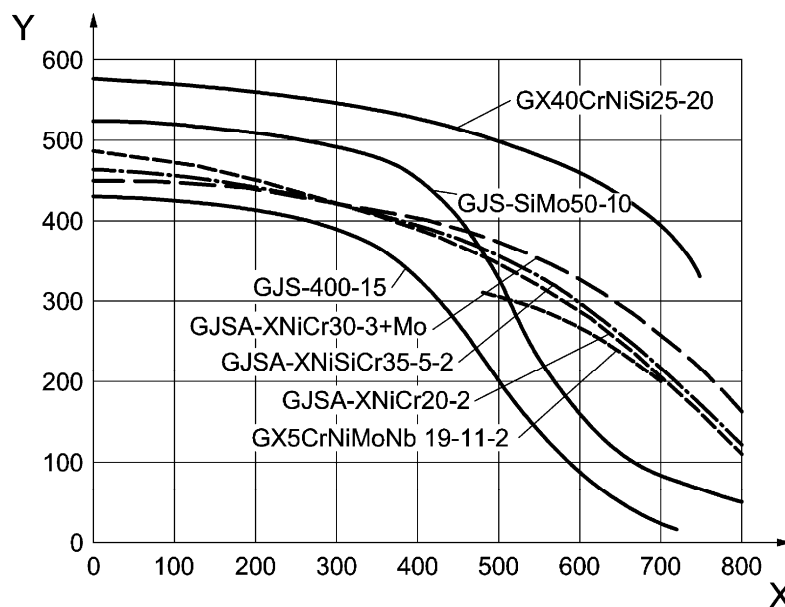

Key

X temperature (°C)

Y tensile strength R_m (MPa)

Figure B.1 — Typical values for temperature dependency of tensile strength of ferritic and austenitic cast iron grades and two cast steel grades

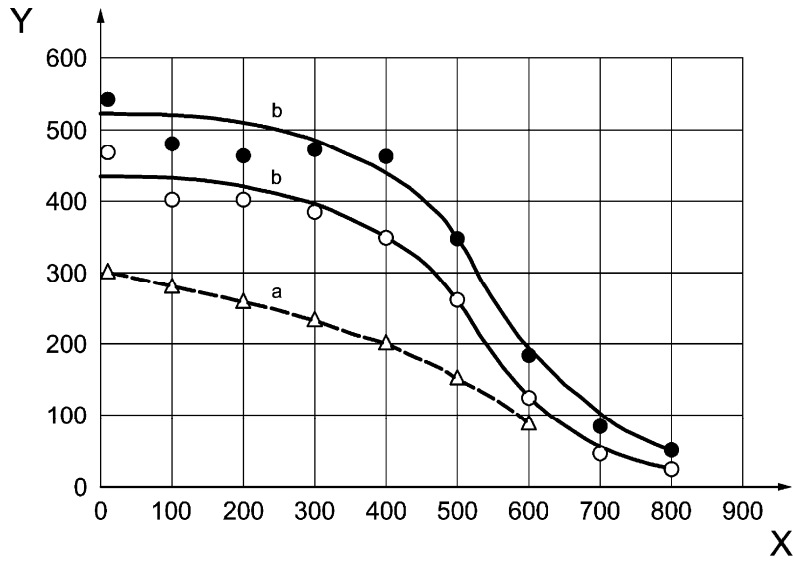

Key

X temperature (°C)

Y tensile strength R_m and 0,2 % proof strength $R_{p0,2}$ (MPa)

^a EN-GJS-400-15: $R_{p0,2}$

^b EN-GJS-SiMo40-10: black dots R_m , white dots $R_{p0,2}$

Figure B.2 — Tensile properties of EN-GJS-400-15 and EN-GJS-SiMo40-10 in temperature range 0 °C to 800 °C

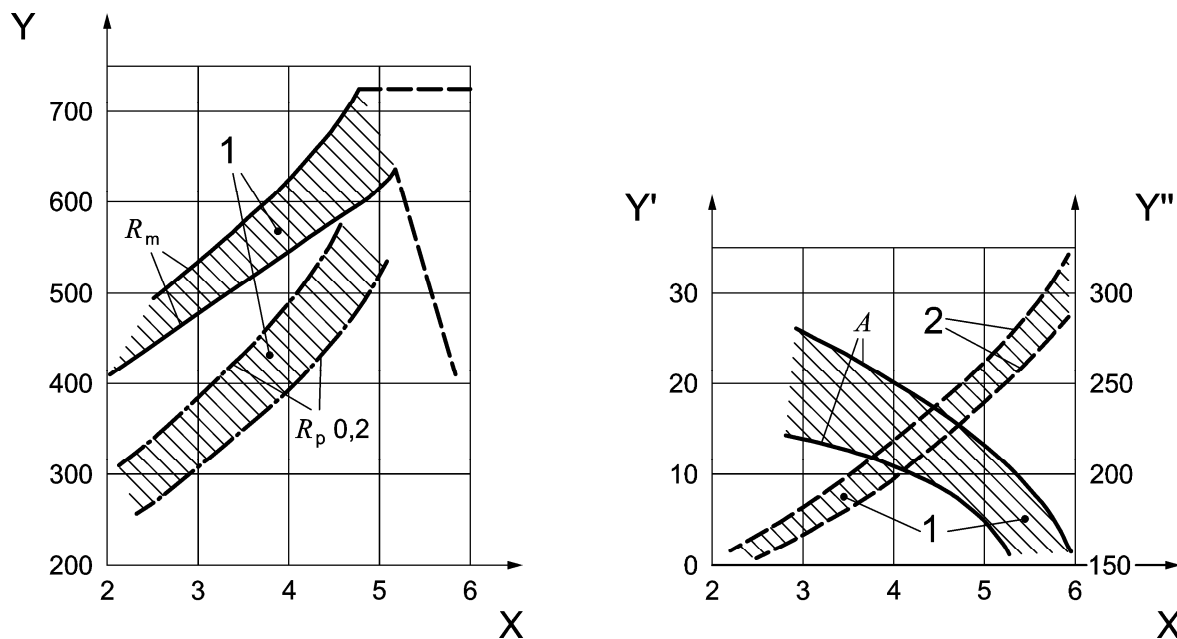

Key

- 1 area of 0 % to 2 % Mo
- 2 Brinell hardness values
- X silicon content (mass fraction, %)
- Y tensile strength R_m and proof strength $R_{p0,2}$ (MPa)
- Y' elongation A (%)
- Y'' Brinell hardness HBW

Figure B.3 — Influence of the silicon content on tensile strength, 0,2 % yield strength, hardness and elongation of ferritised spheroidal graphite cast iron with more than 2,5 % Si and 0 % to 2 % Mo

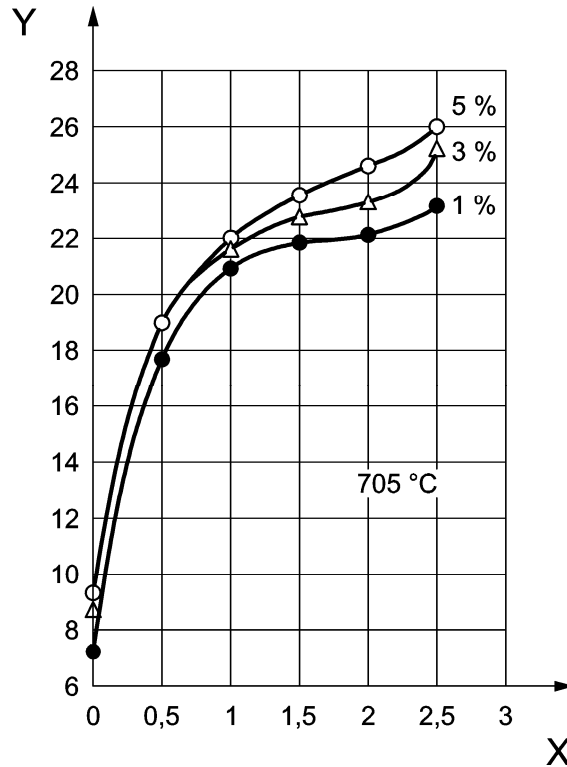

Key

- X molybdenum content (mass fraction, %)
- Y stress (MPa)
- 1 %, 3 %, 5 % permanent strain (ϵ_{per})

Figure B.4 — Influence of the molybdenum content on the 1 000 h time creep limit of ferritised spheroidal graphite cast iron with 4 % Si

Figure B.4 shows that increasing molybdenum content to 2,5 % increases the required stress for a given value of the creep limit by a factor 3 [4].

Figures B.5, B.6 and B.7 show a comparison of the deformation variation with time, for given strengths at 450 °C, for three grades of spheroidal graphite cast irons [8].

On each of these three figures, the number near each curve represents the applied creep stress (MPa). When these curves end with a black point, this corresponds to failure. When the curves are marked with an arrow, this means that the test was interrupted before failure.

Creep presents three steps: initiation, stationary and failure.

The Norton-Bailey equation describes the first two steps.

All conventional spheroidal graphite ferritic irons samples are broken above a 65 MPa stress.

This stress is increased to 150 MPa with a molybdenum addition of 0,5 %.

Increasing silicon content to 3,1 % has little effect, as only creep limit is decreased to 120 MPa.

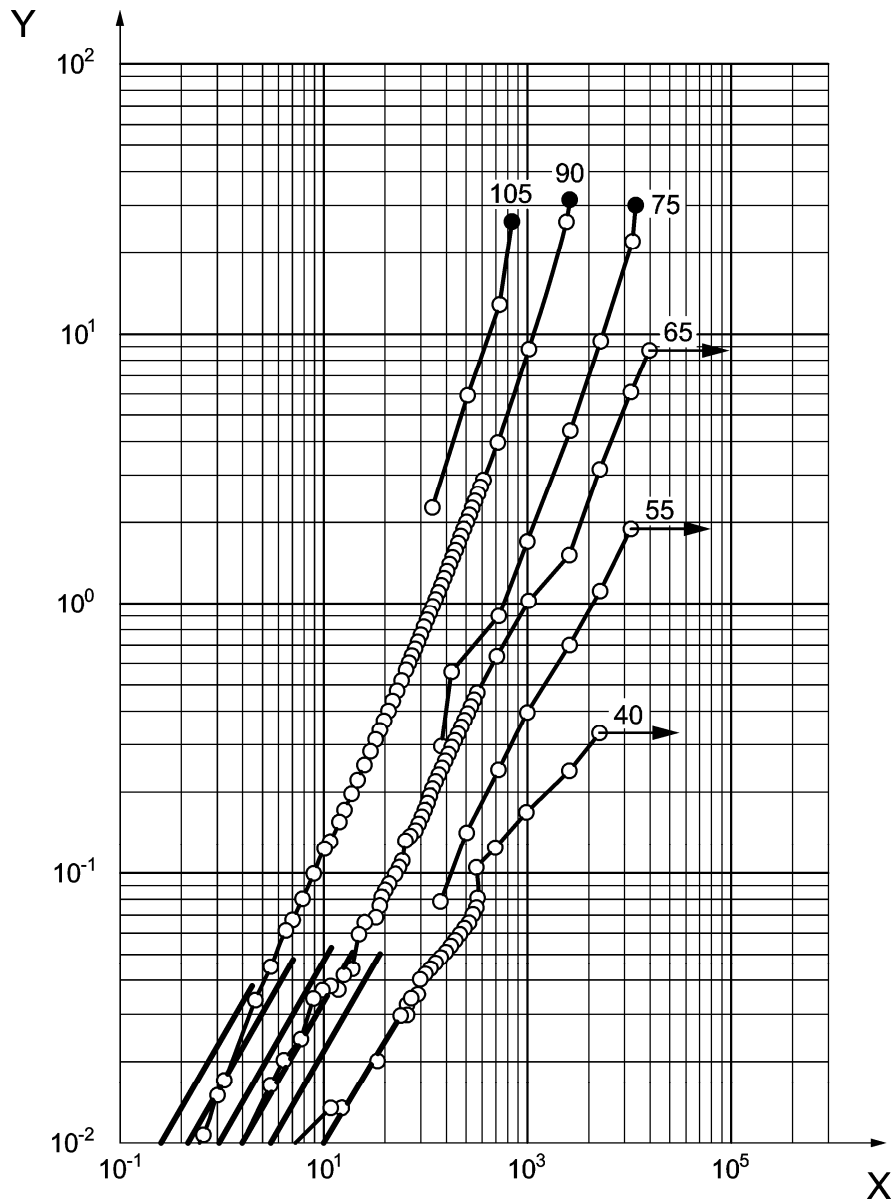

Key

X time (h)

Y permanent strain ϵ_{per} (%)

NOTE The chemical composition of this grade is 3,5 % C, 2,6 % Si, $\leq 0,2$ % Mn, $< 0,1$ % Mo.

Figure B.5 — Creep curves and description of the creeping behaviour with the Norton-Bailey equation for EN-GJS-400-15 at $t = 450$ °C

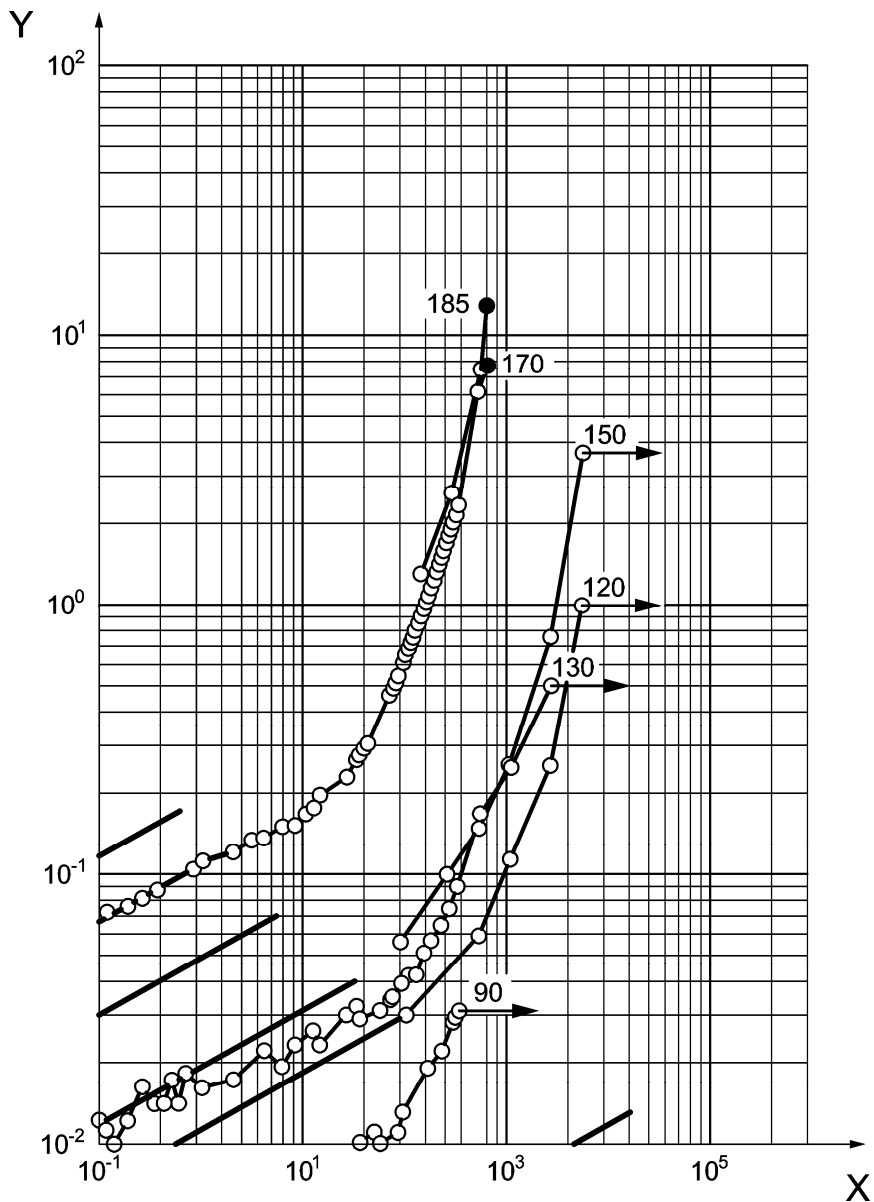

Key

X time (h)

Y permanent strain ϵ_{per} (%)

NOTE The chemical composition of this grade is 3,6 % C, 2,5 % Si, $\leq 0,2$ % Mn, 0,5 % Mo.

Figure B.6 — Creep curves and description of the creeping behaviour with the Norton-Bailey equation for EN-GJS-SiMo 25-5 at $t = 450$ °C

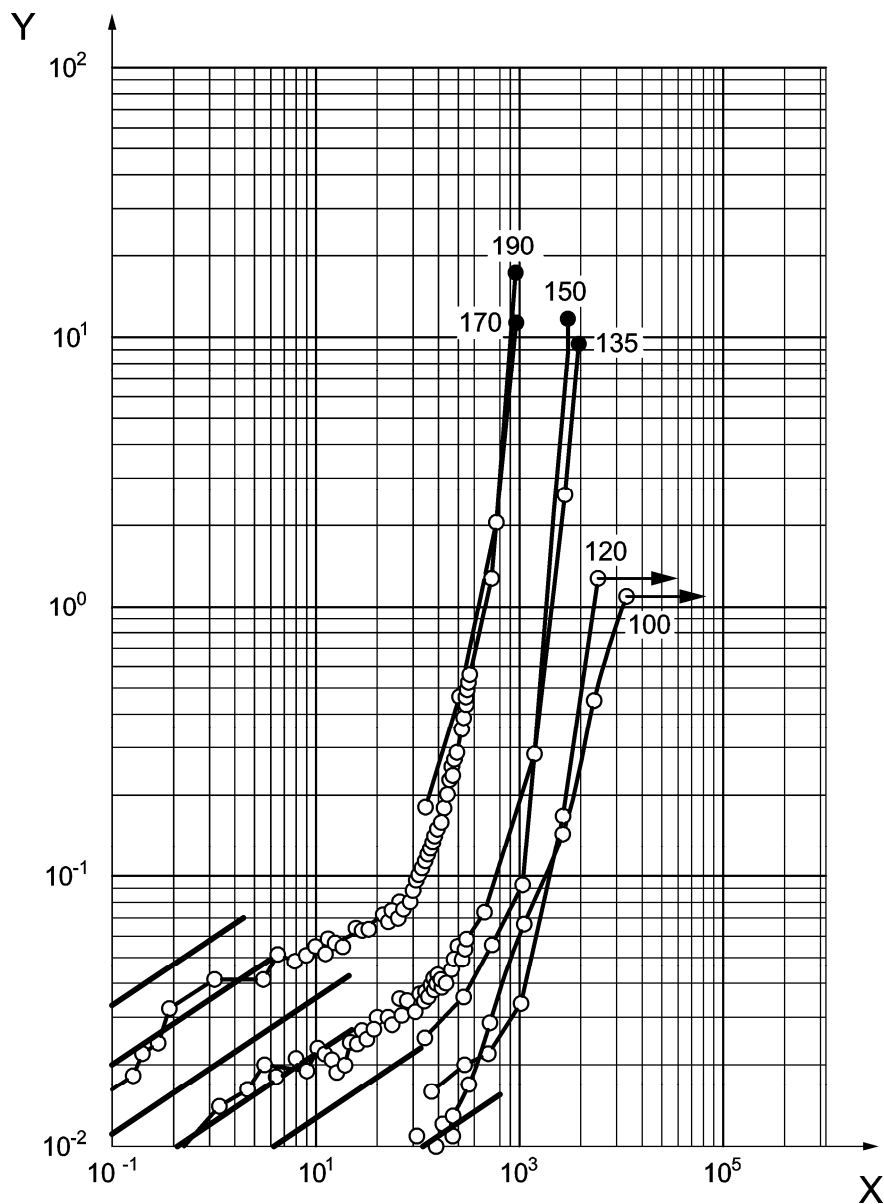

Key

X time (h)

Y permanent strain ϵ_{per} (%)

NOTE The chemical composition of this grade is 3,4 % C, 3,1 % Si, $\leq 0,2$ % Mn, 0,5 % Mo.

Figure B.7 — Creep curves and description of the creeping behaviour with the Norton-Bailey equation for ferritic spheroidal graphite cast iron with 3,1 % Si and 0,50 % Mo at $t = 450$ °C

Figure B.8 shows the variation of elastic modulus E with temperature for EN-GJS-SiMo40-10. The shape of the curve is the same as that of tensile strength (a rapid decrease over 500 °C) [7].

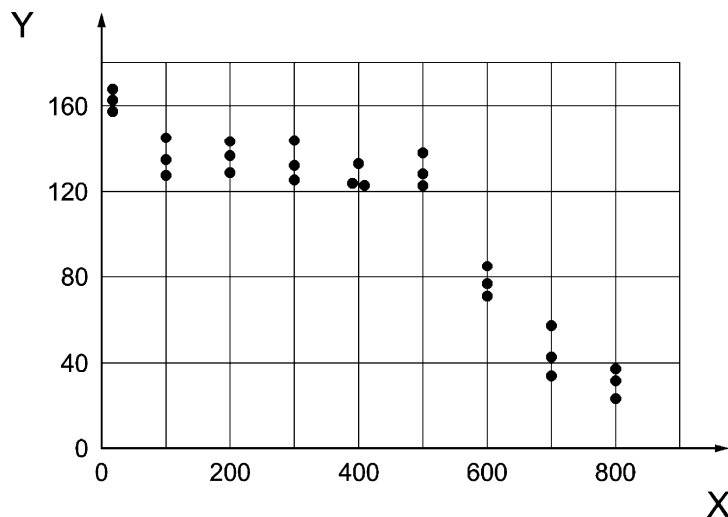

Key

X temperature (°C)

Y elastic modulus (GPa)

Figure B.8 — Dependency of the elastic modulus on the temperature of ferritic spheroidal graphite cast iron with 4,2 % Si and 0,75 % Mo

B.3 Thermal fatigue behaviour

Thermal fatigue occurs when parts are used in an environment with frequent and rapid changes of temperature, generating thermal stresses. These stresses may result in elastic and plastic strains and finally in crack formation. Changes in microstructure (due to stress induced volume changes, surface oxidation, internal oxidation) may also increase the stresses induced by temperature changes.

Interpretation is complicated by the many different test methods used by various investigators.

Figure B.9 shows how silicon and molybdenum improve thermal fatigue resistance (number of cycles heating-cooling until rupture) in low-alloyed ferritic spheroidal cast irons cycled between 200 °C and 650 °C [9].

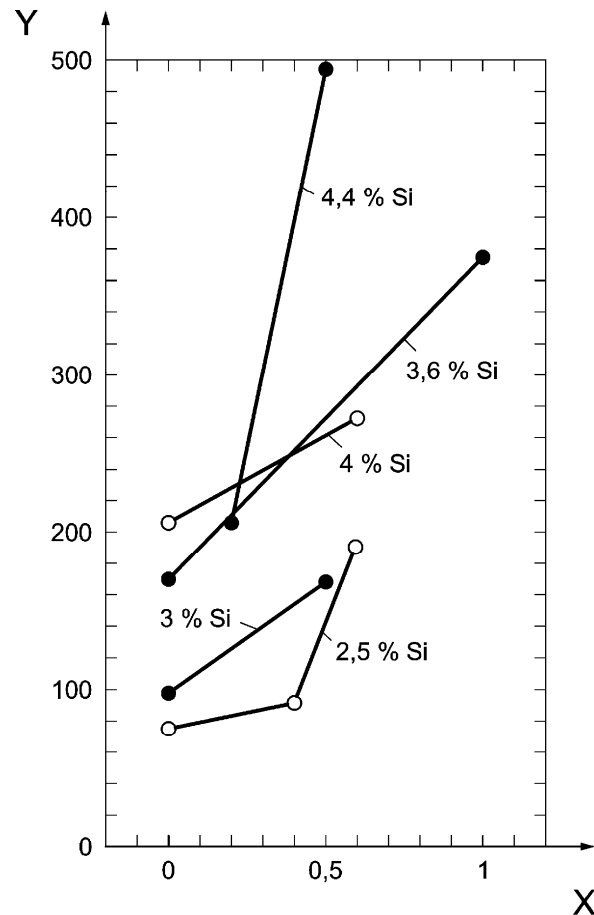

Key

X molybdenum content (mass fraction, %)

Y number of thermal cycles to failure

Figure B.9 — Correlation of thermal fatigue life with molybdenum content in low-alloyed ferritic spheroidal graphite cast iron cycled between 200 °C and 650 °C

B.4 Creep rupture behaviour

There is a continuous increase in the tensile strength and a reduction in creep rate when molybdenum content is increased, from 0 % to 2,5 %.

Alloying with 0,4 % to 1 % molybdenum provides adequate elevated-temperature creep resistance. Higher molybdenum additions tend to generate interdendritic carbide of the Mo_2C type, which persist even through annealing and improve creep resistance at elevated temperature.

Table B.2 shows the effect of cast iron composition on the stress applied to obtain a rupture after 1 000 h at 540 °C. Note the effect of the silicon and molybdenum contents [10].

Table B.2 — Effect of silicon and molybdenum on the high temperature tensile and creep rupture strength of ferritic ductile irons

Material	Tensile strength MPa			Creep strength MPa 1 000 h at 538 °C
	427 °C	538 °C	649 °C	
GJL unalloyed	255	173	83	41
ASTM 60-40-18 (comp. EN-GJS-400-15)	276	173	90	57
GJS with 4 % Si	386	248	90	69
GJS with 4 % Si and 1 % Mo	421	304	131	97
GJS with 4 % Si and 2 % Mo	449	317	138	117

B.5 Oxidation behaviour

Prolonged exposure of irons in air at high temperatures produces a surface scale, primarily by oxidation. The scale consists of a mixture of three iron oxides: an outer layer of Fe_2O_3 , an intermediate layer of Fe_3O_4 , and an inner layer of FeO . This scale is usually continuous and adherent up to 800 °C. The scale may present an adherent and protective type or a cracking type which leads to a continuous oxidation. An adherent scale is associated with a gradually diminishing rate of increase in weight, while a loose or cracked scale permits a rapid gain in weight.

The amount of scaling or gain in weight observed for a graphitic cast iron increases with temperature and exposure time. The relative change depends on the atmosphere and the cast iron composition. The surface oxidation of graphitic cast iron increases very quickly since the temperatures is over 760 °C; this oxidation rate depends on the graphite structure, silicon and alloying elements contents of the cast iron.

Figure B.10 shows the effect of the silicon content on the scaling of spheroidal graphite cast iron, alloyed with 0.9 % Mo, after 96 h at 800 °C in air [4].

Table B.3 compares the scaling of spheroidal graphite cast iron, after 2 000 h at 700 °C [11].

Table B.4 gives values of oxide penetration for different cast iron materials [7] when annealing in air.

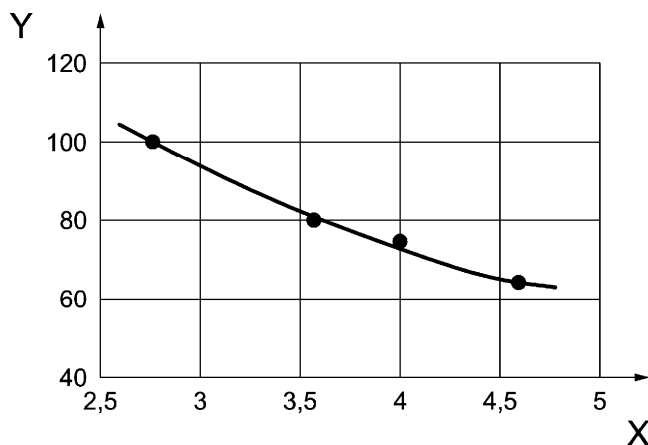

Key

X silicon content (mass fraction, %)

Y oxide layer (μm)

Figure B.10 — Influence of the silicon content on the thickness of the oxide layer at 96 h of annealing in air at 800 °C spheroidal graphite cast iron

Table B.3 — Oxide penetration at 2 000 h and 700 °C

Material	Depth of oxide penetration mm
GJL unalloyed	0,61
ASTM 60-40-18 (comp. EN-GJS-400-15)	0,23
GJS with 4 % Si	0,05
GJS with 4 % Si and 1 % Mo	< 0,02
GJS with 4 % Si and 2 % Mo	< 0,02

**Table B.4 — Guidance values of oxide penetration
when annealing in the air different cast iron materials, specified for 2 000 h,
which were calculated from actual annealing times of 1 000 h to 5 300 h**

Material	Average depth penetration of oxidation after 2 000 h mm Annealing temperature			
	700 °C	800 °C to 815 °C	870 °C	925 °C
Grey cast iron				
1,7 % Si	0,63			
2,0 % Si		1,79		
2,5 % Si	0,86			
Malleable cast iron	0,55			
Spheroidal graphite cast iron				
2,2 % Si ^a	0,24			
2,4 % Si, 2 % Mo ^a	0,19			
2,5 % Si ^a	0,19			
2,8 % Si ^a		0,9		
3,3 % Si ^a		0,26		
4,0 % Si, 0 % to 4 % Mo ^b	0,04	0,17 to 0,21	0,18 ^c	
4,0 % Si, 1 % Al, 1 % to 2 % Mo ^b		0,15 to 0,20		
5,0 % Si, 1 % Mo ^b			0,01 ^c	
5,5 % Si ^a	0,025		0,01 ^c	< 0,05 ^c
5,9 % Si, 1 % Mo ^b				
Austenitic cast iron				
EN-GJL-NiCr 20 2	0,95 to 1,36	2,2 to 3,1		
EN-GJS-NiCr 20 2	0,19 to 0,24	0,49 to 1,88		
EN-GJS-NiCr 20 3	0,24	0,40		
EN-GJS-Ni 22	0,33	1,32		
EN-GJS-NiSiCr 20 4 2	0,24	0,33		
EN-GJS-NiCr 30 3	0,24	0,38		
EN-GJS-NiSiCr 30 5 5	0,025	< 0,15 ^d		
Steel				
Unalloyed rolled steel	1,12			
12 % Cr-steel	0			
^a Normalized ^b Ferritised ^c After 50 annealings, 20 h each ^d From 500 h annealings, approximated				

Annex C
(informative)

Additional information on general mechanical and physical properties

**Table C.1 — Additional mechanical and physical properties
for low alloyed ferritic spheroidal graphite cast iron ¹⁾**

Characteristic	Symbol	Unit	Typical values
Density	ρ	g / cm ³	6,8 to 7,1
Linear thermal expansion coefficient from 20 °C to 200 °C	α	µm / (m K)	11 to 13
Thermal conductivity at 100 °C Thermal conductivity at 400 °C	λ	W / (m K)	22 to 26 25 to 30
Heat capacity at 20° C to 100 °C	c	J / kg K	500 to 720
Modulus of elasticity at 20 °C	E	GPa	160 to 180
Poisson's ratio	ν		0,28 to 0,35

¹⁾ See [12].

Annex D (informative)

Heat treatment ²⁾

The low-alloyed ferritic spheroidal graphite cast irons are predominant, ferritic as-cast, but the presence of carbide stabilizing elements will result in a certain amount of pearlite and often intercellular carbides. These alloys can have higher levels of residual stress due to a lower thermal conductivity and higher elevated-temperature strength as compared to conventional ferritic grades. These factors should be taken into account when deciding on heat treatment requirements.

For the 2,5 % to 3 % silicon alloyed ferritic spheroidal graphite cast irons, high-temperature heat treatment can be applied to anneal excessive pearlite and stabilize the casting against growth in service or to minimize eutectic carbides.

For the 4 % to 5 % silicon alloyed ferritic spheroidal graphite cast irons this will require heating to at least 900 °C for several hours, followed by slow cooling to below 700 °C.

²⁾ See [13].

Annex E **(informative)**

Nodularity

The nodularity of spheroidal graphite cast iron is defined as the percentage of graphite particles that are spheroidal or nodular in shape (form V and VI of EN ISO 945-1).

While the number of particles is detected by $100 \times$ magnification, the determination of the form and its percentage should be done with a magnification which shows the graphite particles in approximately the size according to EN ISO 945-1:2008, Figure 1. While the classification of the graphite form is accomplished on the basis of this European Standard in comparison to reference pictures, the computer aided image analysis with specific software parameters might be applied for this material as well.

Nodularity not only depends on the production process influenced, for example, by the chemical composition, the remaining magnesium concentration or the inoculation method, but also on the solidification rate of the melt in the respective wall areas. Furthermore, it is possible to influence the graphite form in the contact area of the mould area as well.

The nodule roundness marks only one aspect of the material quality. Further parameters influencing the material qualities are, among others, the number of graphite particles and their distribution, the pearlite concentration and its arrangement, the solid solution strengthening of the ferrite and possible microshrinkage. Concerning the guarantee of the minimum material properties specified in this European Standard, it is therefore impossible to define precise standards of nodularity for certain solidification modulus.

However, experience shows that a level of nodularity of 80 % or more generally ensures the minimum tensile properties specified in this European Standard, as long as the matrix of the chosen variety is adjusted accordingly. Most of the of graphite not being in of form V and VI is then in form IV and possibly in form III (and may even be of form II in thick walled castings). Due to the increased silicon content, these low-alloyed ferritic spheroidal graphite cast irons may show some compacted graphite (form III) in heavy sections.

For castings subjected to severe loading, in particular under fatigue conditions, a higher nodularity (including requirements for a specific percentage of form V and VI graphite) may be required. Such a requirement should be evaluated by an experimental study, specific to the casting and the material grade.

Annex F (normative)

Sectioning procedure for cast samples

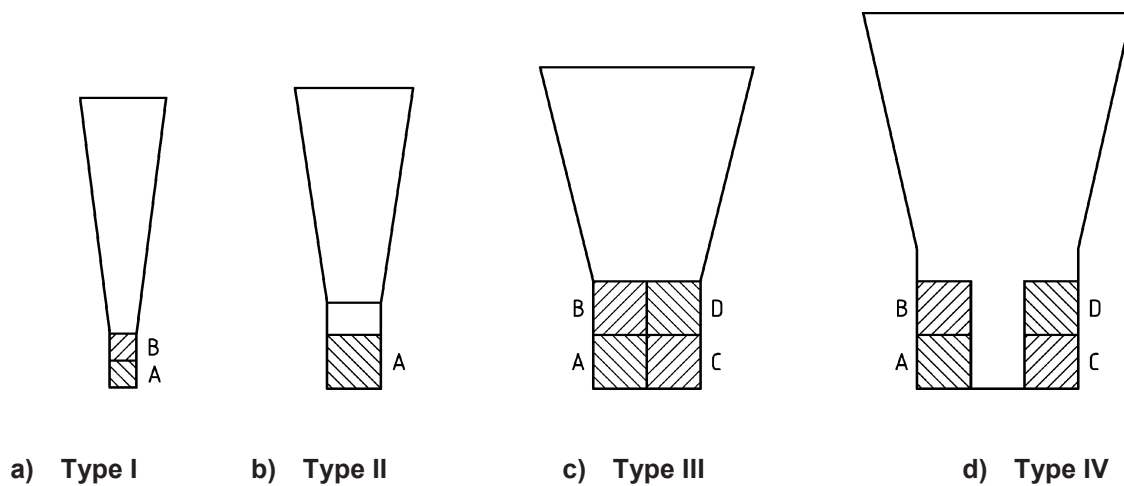

Figure F.1 — Sectioning procedure for Y-shaped samples (see Figure 2)

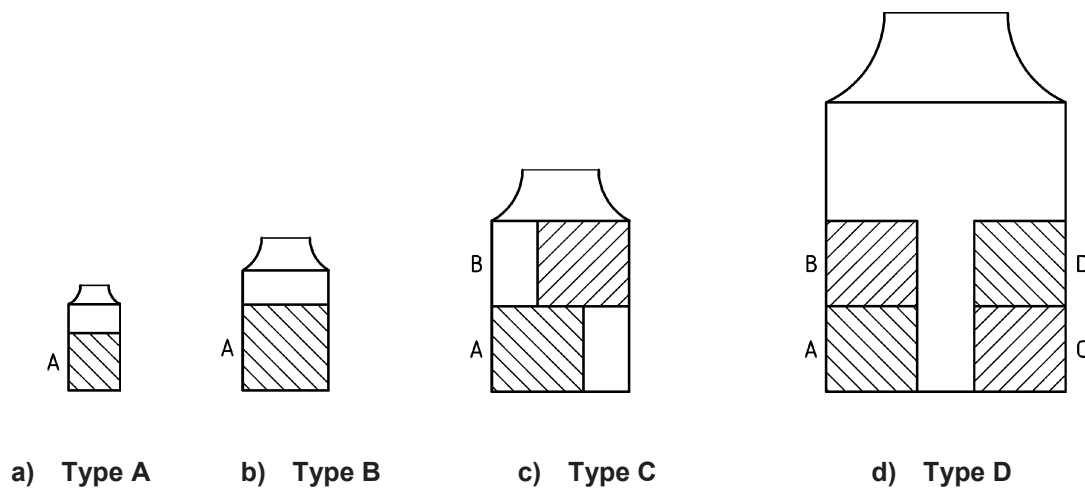

Figure F.2 — Sectioning procedure for cast-on samples (see Figure 4)

Bibliography

- [1] EN 1559-1, *Founding — Technical conditions of delivery — Part 1: General*
- [2] EN 1559-3, *Founding — Technical conditions of delivery — Part 3: Additional requirements for iron castings*
- [3] EN 1560, *Founding — Designation system for cast iron — Material symbols and material numbers*
- [4] Röhrig: Guss für den Motorenbau, Teil 1: Werkstoffe für Abgaskrümmen und Turboladergehäuse. Gießerei-Praxis, 2002-04, S. 140-143
- [5] Röhrig: Eigenschaften von unlegiertem und niedriglegiertem Gusseisen mit Kugelgraphit bei erhöhten Temperaturen. Taschenbuch der Gießerei-Praxis, 1985, Schiele & Schön GmbH, S. 316-335
- [6] Georg Fischer AG, Schaffhausen (Schweiz): GGG-SiMo 51 — Ein warmfester duktiler +GF+ Gusswerkstoff. Technisches Merkblatt, S. 3
- [7] Röhrig: Hitzebeständiges GGG mit 4 bis 6 % Silicium — Eigenschaften. Konstruieren und Gießen 3, 1978, No 4, S. 4-13
- [8] Berger, Roos, Mao, Udoh; Scholz, Klenk: Hochtemperaturverhalten von Gusseisen mit Kugelgraphit. Bericht über das Vorhaben des Vereins Deutscher Gießereifachleute (VDG), 2005, S. 53-72
- [9] Gundlach, Weber, Santanam, Thoma: Thermal fatigue resistance of silicon-molybdenum ductile iron. The ductile iron society's 1998 Keith D. Mills World Symposium on ductile iron, 1998, p 379-398
- [10] Kruse: Should you add ADI, CGI, SiMo, to your iron menu? Engineered casting solutions, 2006, p 34-35
- [11] Vidyasagar: Exhaust manifolds in Si-Mo S. G. iron. Indian Foundry Journal, 1998, Vol. 11, S. TP178-TP180
- [12] NF A 32-501, *Produits de fonderie — Fontes à graphite sphéroïdal ferritiques au silicium molybdène* ³⁾
- [13] Knowledge Article from www.Key-to-Steel.com, www.keytometals.com/

³⁾ In English: *Foundry products — Silicon Molybdenum ferritic cast iron*

British Standards Institution (BSI)

BSI is the national body responsible for preparing British Standards and other standards-related publications, information and services.

BSI is incorporated by Royal Charter. British Standards and other standardization products are published by BSI Standards Limited.

About us

We bring together business, industry, government, consumers, innovators and others to shape their combined experience and expertise into standards-based solutions.

The knowledge embodied in our standards has been carefully assembled in a dependable format and refined through our open consultation process. Organizations of all sizes and across all sectors choose standards to help them achieve their goals.

Information on standards

We can provide you with the knowledge that your organization needs to succeed. Find out more about British Standards by visiting our website at bsigroup.com/standards or contacting our Customer Services team or Knowledge Centre.

Buying standards

You can buy and download PDF versions of BSI publications, including British and adopted European and international standards, through our website at bsigroup.com/shop, where hard copies can also be purchased.

If you need international and foreign standards from other Standards Development Organizations, hard copies can be ordered from our Customer Services team.

Subscriptions

Our range of subscription services are designed to make using standards easier for you. For further information on our subscription products go to bsigroup.com/subscriptions.

With **British Standards Online (BSOL)** you'll have instant access to over 55,000 British and adopted European and international standards from your desktop. It's available 24/7 and is refreshed daily so you'll always be up to date.

You can keep in touch with standards developments and receive substantial discounts on the purchase price of standards, both in single copy and subscription format, by becoming a **BSI Subscribing Member**.

PLUS is an updating service exclusive to BSI Subscribing Members. You will automatically receive the latest hard copy of your standards when they're revised or replaced.

To find out more about becoming a BSI Subscribing Member and the benefits of membership, please visit bsigroup.com/shop.

With a **Multi-User Network Licence (MUNL)** you are able to host standards publications on your intranet. Licences can cover as few or as many users as you wish. With updates supplied as soon as they're available, you can be sure your documentation is current. For further information, email bsmusales@bsigroup.com.

BSI Group Headquarters

389 Chiswick High Road London W4 4AL UK

Revisions

Our British Standards and other publications are updated by amendment or revision.

We continually improve the quality of our products and services to benefit your business. If you find an inaccuracy or ambiguity within a British Standard or other BSI publication please inform the Knowledge Centre.

Copyright

All the data, software and documentation set out in all British Standards and other BSI publications are the property of and copyrighted by BSI, or some person or entity that owns copyright in the information used (such as the international standardization bodies) and has formally licensed such information to BSI for commercial publication and use. Except as permitted under the Copyright, Designs and Patents Act 1988 no extract may be reproduced, stored in a retrieval system or transmitted in any form or by any means – electronic, photocopying, recording or otherwise – without prior written permission from BSI. Details and advice can be obtained from the Copyright & Licensing Department.

Useful Contacts:

Customer Services

Tel: +44 845 086 9001

Email (orders): orders@bsigroup.com

Email (enquiries): cservices@bsigroup.com

Subscriptions

Tel: +44 845 086 9001

Email: subscriptions@bsigroup.com

Knowledge Centre

Tel: +44 20 8996 7004

Email: knowledgecentre@bsigroup.com

Copyright & Licensing

Tel: +44 20 8996 7070

Email: copyright@bsigroup.com



...making excellence a habit.™