



BSI Standards Publication

Tanks for transport of dangerous goods — Digital interface for the data transfer between tank vehicle and with stationary facilities

Part 2: Commercial and logistic data

National foreword

This British Standard is the UK implementation of EN 15969-2:2011.

The UK participation in its preparation was entrusted to Technical Committee AUE/18, Tanks for the transport of dangerous goods.

A list of organizations represented on this committee can be obtained on request to its secretary.

This publication does not purport to include all the necessary provisions of a contract. Users are responsible for its correct application.

© BSI 2011

ISBN 978 0 580 69052 5

ICS 13.300; 23.020.10; 35.240.60

Compliance with a British Standard cannot confer immunity from legal obligations.

This British Standard was published under the authority of the Standards Policy and Strategy Committee on 31 October 2011.

Amendments issued since publication

Date	Text affected
------	---------------

EUROPEAN STANDARD

EN 15969-2

NORME EUROPÉENNE

EUROPÄISCHE NORM

September 2011

ICS 35.240.60

English Version

Tanks for transport of dangerous goods - Digital interface for the data transfer between tank vehicle and with stationary facilities - Part 2: Commercial and logistic data

Citernes destinées au transport de matières dangereuses - Interface numérique pour le transfert de données sur des véhicules citernes et avec des installations fixes - Partie 2 : Données commerciales et logistiques

Tanks für die Beförderung gefährlicher Güter - Digitale Schnittstelle für den Datenaustausch zwischen Tankfahrzeugen und stationären Einrichtungen - Teil 2: Kommerzielle und logistische Daten

This European Standard was approved by CEN on 18 June 2011.

CEN members are bound to comply with the CEN/CENELEC Internal Regulations which stipulate the conditions for giving this European Standard the status of a national standard without any alteration. Up-to-date lists and bibliographical references concerning such national standards may be obtained on application to the CEN-CENELEC Management Centre or to any CEN member.

This European Standard exists in three official versions (English, French, German). A version in any other language made by translation under the responsibility of a CEN member into its own language and notified to the CEN-CENELEC Management Centre has the same status as the official versions.

CEN members are the national standards bodies of Austria, Belgium, Bulgaria, Croatia, Cyprus, Czech Republic, Denmark, Estonia, Finland, France, Germany, Greece, Hungary, Iceland, Ireland, Italy, Latvia, Lithuania, Luxembourg, Malta, Netherlands, Norway, Poland, Portugal, Romania, Slovakia, Slovenia, Spain, Sweden, Switzerland and United Kingdom.



EUROPEAN COMMITTEE FOR STANDARDIZATION
COMITÉ EUROPÉEN DE NORMALISATION
EUROPÄISCHES KOMITEE FÜR NORMUNG

Management Centre: Avenue Marnix 17, B-1000 Brussels

Contents

Page

Foreword.....	3
Introduction	4
1 Scope	6
2 Normative references	6
3 Terms and definitions	6
4 General.....	7
5 Files	7
5.1 Format identifiers.....	7
5.2 Relations	8
5.3 File naming conventions.....	11
6 Fields of special types	11
6.1 Text module reference	11
6.2 Geo-Coordinates.....	12
6.3 UTF-8 strings.....	12
7 Price calculation rules.....	12
7.1 General.....	12
7.2 Low volume (surcharge)	12
7.3 Pricing of packed products, container, pieces.....	13
7.3.1 Article records.....	13
7.3.2 Low volume (surcharge)	13
7.3.3 Price calculation methods	13
7.4 Taxes.....	14
8 Description of trip management.....	14
8.1 Handling of several trips.....	14
8.2 Handling of a pseudo-trip with a pool of orders.....	14
8.3 Handling of orders	14
8.4 Handling of products.....	15
9 Fields and records of RC_File	15
10 Multi-Order Data (Subnode RC_FILE).....	40
10.1 General.....	40
10.2 Node RC_File.....	40
10.3 Information concerning application.....	41
10.3.1 Simple trip plan, using FTL connection	41
10.3.2 Simple Trip Plan, Using FTP and RC_FILE	42
10.3.3 Managing static data, using FTL connection.....	44
10.3.4 Managing static data under FTP	44

Foreword

This document (EN 15969-2:2011) has been prepared by Technical Committee CEN/TC 296 "Tanks for transport of dangerous goods", the secretariat of which is held by AFNOR.

This European Standard shall be given the status of a national standard, either by publication of an identical text or by endorsement, at the latest by March 2012, and conflicting national standards shall be withdrawn at the latest by March 2012.

Attention is drawn to the possibility that some of the elements of this document may be the subject of patent rights. CEN [and/or CENELEC] shall not be held responsible for identifying any or all such patent rights.

This European Standard EN 15969, *Tanks for transport of dangerous goods – Digital interface for the data transfer between tank vehicle and with stationary vehicles*, is divided into the following parts:

Part 1 — Protocol Specification – Control, measurement and event data

Part 2 — Commercial and logistic data

According to the CEN/CENELEC Internal Regulations, the national standards organizations of the following countries are bound to implement this European Standard: Austria, Belgium, Bulgaria, Croatia, Cyprus, Czech Republic, Denmark, Estonia, Finland, France, Germany, Greece, Hungary, Iceland, Ireland, Italy, Latvia, Lithuania, Luxembourg, Malta, Netherlands, Norway, Poland, Portugal, Romania, Slovakia, Slovenia, Spain, Sweden, Switzerland and the United Kingdom.

Introduction

FTL is an acronym for **Fuel Truck Link**, the interface between electronic system(s) on board of a tank truck (Tank-Vehicle-Equipment) and any external computer, Part 2 mainly for a host installed in the office and connected via Internet (TCP/IP); for illustration, see Figure 1.

This European Standard specifies data format for all interconnecting communication paths for commercial issues.

This European Standard offers the user following features:

- Multiple orders (batch processing);
- Pricing;
- Master data (e.g. products, customers, drivers, taxes);
- Additional texts for the printout;
- Information for the drivers;
- Trip management;
- Data for invoicing with surcharge;
- Data for delivery packaged goods;
- Handle planned and unplanned deliveries.

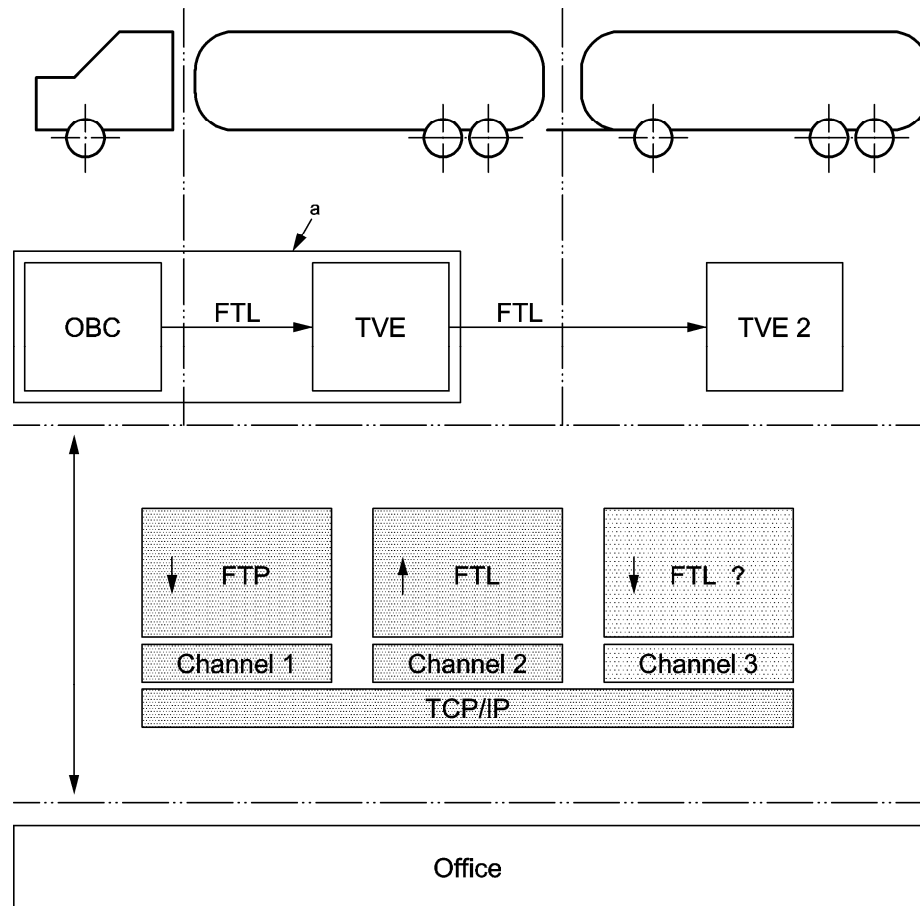

Key

- direction of communication (client → server)
- a may be either two independent units or one single unit which incorporates both functions OBC and TVE

Figure 1 — Communication structure

1 Scope

This European Standard specifies the data structure needed for tour management, scheduling orders of measured and unmeasured products online to the truck. Processed orders are transferred back to the host in the office at once or later every time the truck is online.

It specifies the transfer of commercial and logistic data between transport vehicle equipment, on board computer of the tank vehicle and stationary facilities for all communication channels between these parties.

2 Normative references

The following referenced documents are indispensable for the application of this document. For dated references, only the edition cited applies. For undated references, the latest edition of the referenced document (including any amendments) applies.

EN 14116, *Tanks for transport of dangerous goods — Digital interface for the product recognition device*

EN 15969-1:2011, *Tanks for transport of dangerous goods — Digital interface for the data transfer between tank vehicle and with stationary facilities — Part 1: Protocol specification — Control, measurement and event data*

EN ISO 3166-1; *Codes for the representation of names of countries and their subdivisions — Part 1: Country codes (ISO 3166-1:2006)*

ISO 639-1, *Codes for the representation of names of languages — Part 1: Alpha-2 code*

ISO 4217, *Codes for the representation of currencies and funds*

ISO/IEC 10646-1, *Information technology — Universal Multiple-Octet Coded Character Set (UCS) — Part 1: Architecture and Basic Multilingual Plane*

3 Terms and definitions

For the purposes of this document, the terms and definitions given in EN 15969-1:2011 and the following apply.

3.1 dispatcher

person who manages tour at the host system

3.2 operator (driver)

person who operates the truck and the truck management computer

3.3 tour

set of at least one 'Order Record' and related records, which describes a collection of stops at different customers and the ordered products, so that the driver knows where to go and what to deliver

3.4 article

goods and/or services provided

4 General

This document shall only be used in conjunction with EN 15969-1 and shall not modify or override any of the requirements of EN 15969-1.

5 Files

5.1 Format identifiers

According to EN 15969-1.

Table 1 — Record identifier and file type

Record identifier	Short description	Description of file contents and possible destinations of the file	Primary Key	Deletion Identifier
A	Article	List of all goods and/or services provided	a_art_id	a_deleted
C	Customer	Customer database	c_cus_id	c_deleted
FB	FTL batch	Record type used to mark batch commands inside RC_file; see Table 11.	-	-

Table 1 (continued)

Record identifier	Short description	Description of file contents and possible destinations of the file	Primary Key	Deletion Identifier
H	Trip	A trip consists of a list of trip stops, which could be stops at customers (typ. unloading) or depots (typ. loading).	h_tour_no	h_deleted
L	Location	All locations (depots, customers, etc)	l_loc_id	l_deleted
LR	Location restriction	Restrictions for a location (time windows, vehicle accessibility, permitted actions)	lr_loc_id	lr_deleted
N	Notes	Notes that can be specified for any object.	n_ref_obj n_obj_id n_seq_no	n_deleted
O	Order	Represents a stop in a trip. This could be both a loadstop and an orderstop. per stop, several actions can be performed. These are specified in the p-records of this o-record. If field o_ord_id is 0, the order is unplanned	o_tour_no o_ord_no	o_deleted
OR	Order restrictions	Order restrictions, used for scheduling and routing.	or_ord_id	or_deleted
P	Order lines	Specifies the goods and services to be delivered at this stop (o-record).	p_tour_no p_ord_no p_pos_no	p_deleted
R	Driver	List of all drivers	r_drv_id	r_deleted
S	Text-module reference	Static texts for any object. provides text module references, to add a variable number of static texts to an object for printout.	s_ref_obj s_obj_id s_seq_no	s_deleted
T	Tax	Different applicable VAT rates, used for invoice calculation.	t_tax_id	t_deleted
X	Text modules	Texts which are repetitively used, may be stored in this database and referred to by a three-digit numeric code in the S-record.	x_blk_id x_lang_id	x_deleted
Y	Annotations	Optional annotations to any other type, this annotations are used to add manufacturer specific fields to any record, which trigger an action on the truck and are not only used for printout. It is not allowed to define fields of type y within this standard.	y_ann_obj y_obj_id y_ann_key	y_deleted

5.2 Relations

Figure 2 shows the relations between the different record types and contains only the fields relevant for these relations.

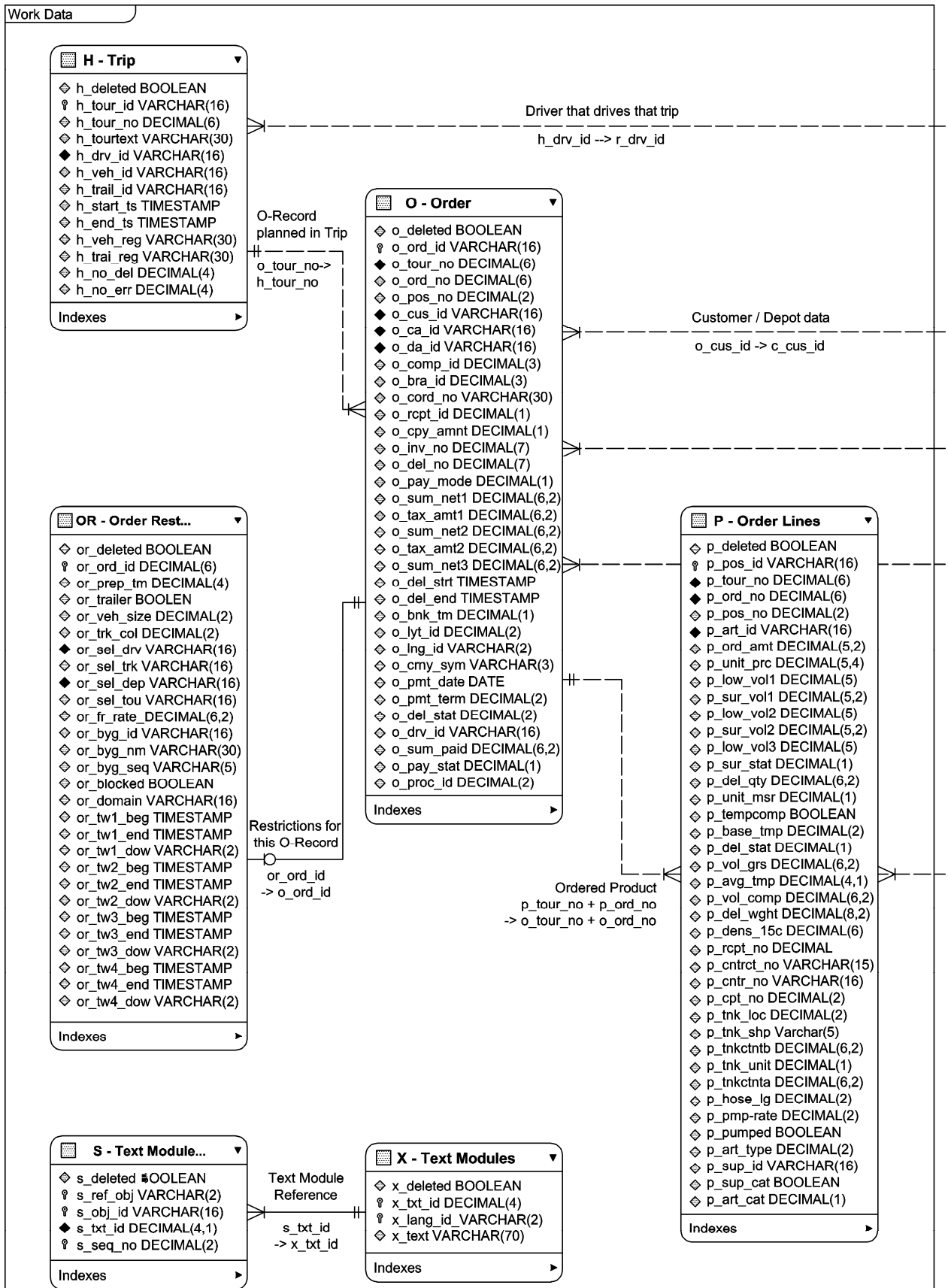

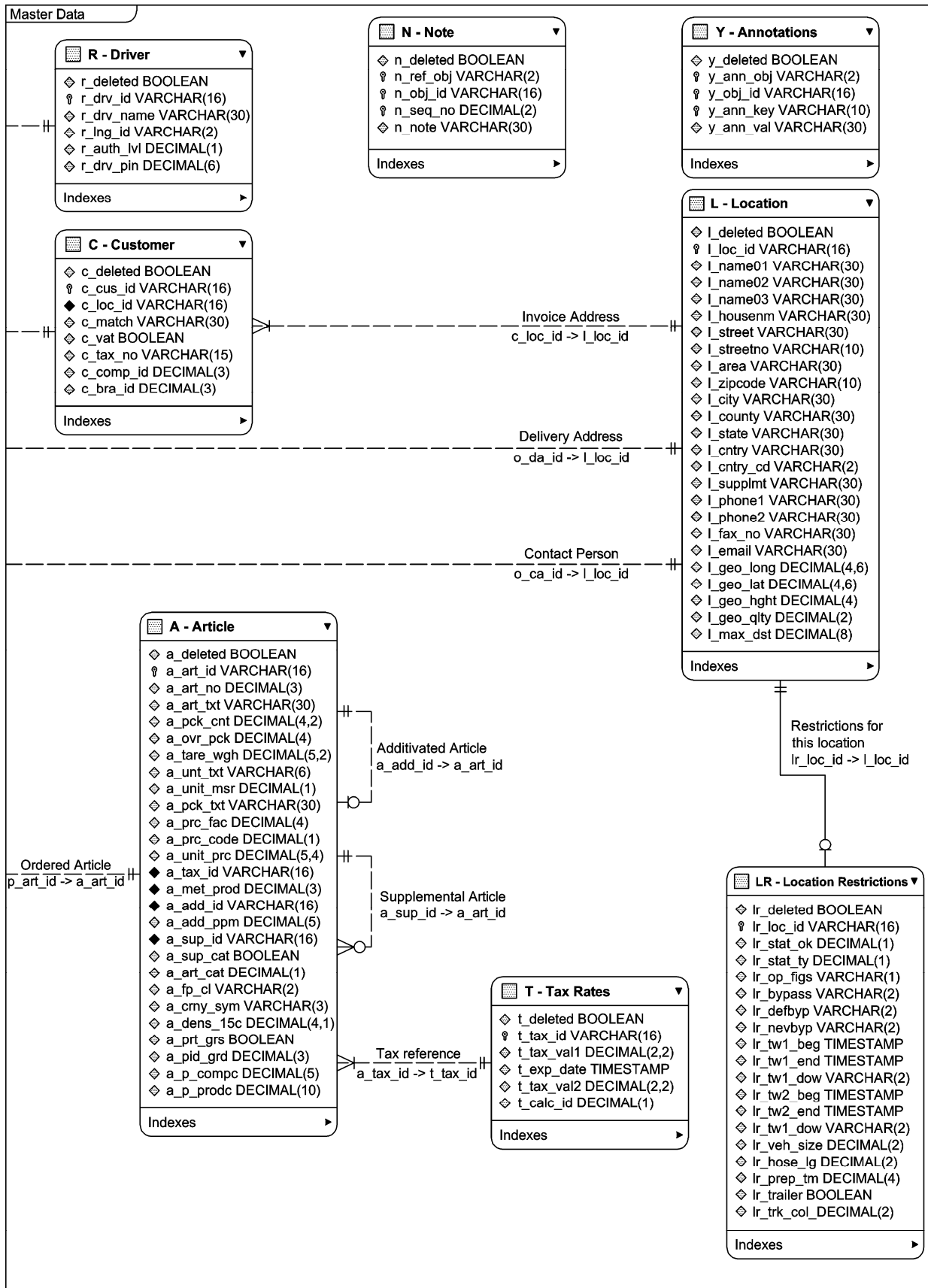

Key



<i>Symbol</i>	<i>Meaning</i>
	Primary key, shall be unique
	Foreign key, this attribute is referencing/reference
	Attribute
≡-----≡	One-to-one relationship, both objects shall exist
≡-----○	One-to-one relationship, the object on the right side is optional (zero or one)
≡-----<≡	One-to-many relationship, both objects shall exist
≡-----○<≡	One-to-many relationship, the object on the right side is optional (zero, one or many)

Figure 2 — Work data and master data

5.3 File naming conventions

When files are being transferred using FTP connection, the file(s) shall be named RC_CCYYMMDDhhmmss.FTL. CCYYMMDDhhmmss is the timestamp according to Table 3 of EN 15969-1:2011.

If more than one file is transferred, they shall be processed in ascending order of file names.

6 Fields of special types

6.1 Text module reference

Table 2 — Text module reference

Type	Size	Explanation
R	N4.1	Text module reference

Text module fields according to Table 2 have the special functionality described below.

The text module selection will be done by a key number. Each record of type X can be used as a single line or as a set of lines. To differentiate between single line and set, the pointer has a special structure.

The text module reference s_txt_id is defined as a numeric value with the size: 4.1.

The text module reference s_txt_id, is defined as a numeric value with the size: 4.1. The leading 4 digit number is the key-field of the record of type X (field x_txt_id). The 1 digit number behind the decimal point counts the number of records following the first record, i.e. this number is used to increment the pointer.

EXAMPLE

Value	Explanation
99.0	Only record no. 99 is printed.
99.2	Record no. 99, 100, 101 are printed.

6.2 Geo-Coordinates

Geo-coordinate fields shall be according to Table 3.

Table 3 — Geo-coordinate field

Type	Size	Explanation
G	N4.6	<p>Longitude and latitude values shall be in degrees and decimal fractions of degree:</p> <ul style="list-style-type: none"> — negative value of longitude is west of Greenwich; positive value is east of Greenwich; — positive value of latitude is north of equator; negative value is south of equator. <p>Examples for longitude GPS: +007.512500 = 7,512500° E = 7° 30' 45" E = 7° 0,750' E 7. 5125 = 7,512500° E = 7° 30' 45" E -007. 512500 = 7,512500° W = 7° 30' 45" W</p> <p>Examples for latitude GPS: +07.512500 = 7,512500° N = 7° 30' 45" N</p>

6.3 UTF-8 strings

UTF-8 strings according to Table 4.

Table 4 — UTF-8 string field

Type	Explanation
Ux	Text with maximum length of x printable characters coded in UTF-8 according to ISO/IEC 10646-1. At most, x-times four bytes are required for storage.

7 Price calculation rules

7.1 General

All prices shall be net prices.

7.2 Low volume (surcharge)

In the event of the actual delivered volume being less than the planned delivered volume, negative price discounts (surcharges) may be applied.

These fields are used to calculate the applicable surcharges. Two surcharge levels are allowed, depending on the difference between the actual delivered volume and the planned delivered volume. For example, if this difference is between "p_low_vol1" and "p_low_vol2" then surcharge "p_sur_vol1" shall be used, and if between "p_low_vol2" and "p_low_vol3" then surcharge "p_sur_vol2" shall be used.

In any of these cases the driver has the possibility to change from invoice to delivery note.

Where the actual delivered volume is so small that it is less than "p_low_vol3", (the limit of prior agreed surcharges) then no price calculation shall be made and only a delivery ticket issued.

Formula:

price = p_del_qty * p_unit_price / a_prc_fac

surcharge = p_del_qty * p_sur_voln / a_prc_fac

7.3 Pricing of packed products, container, pieces

7.3.1 Article records

Packed goods can also be delivered, packed goods have no a_met_prod, a_met_prod is the reference to the metered product on the truck.

7.3.2 Low volume (surcharge)

For this type of product there are also quantity limits available. The conditions are the same as for liquid products.

7.3.3 Price calculation methods

— by piece ('a_prc_code' = 0)

If a_pck_cnt=0 the driver inputs the number of pieces, which is stored in p_del_qty. If a_pck_cnt>0, the driver inputs the number of packings, the quantity is calculated by a multiplication of the number of packings and a_pck_cnt is stored in the data field p_del_qty. The price will be the unit price p_unit_prc. The a_prc_fac shall be taken into consideration. The text for unit of measure is given in a_unit_txt, e.g. can.

Price-Formula:

price = p_del_qty * p_unit_prc / a_prc_fac

— by quantity ('a_prc_code' = 1)

If a_case_cnt>0, a special calculation shall be made to get the delivered quantity 'p_del_qty'. The text for unit of measure is given in 'p_unit_msr'. If a_case_cnt=0, the driver inputs the quantity directly.

Formula:

p_del_qty = number of packings * a_pck_cnt
price = p_del_qty * p_unit_prc / a_prc_fac

— by fixed price ('a_prc_code' = 2)

A price calculation is not needed because this price is negotiated. No quantity input is necessary, the delivered quantity is the preset quantity, text for unit of measure is given in 'p_unit_msr'.

Formula:

$$\text{price} = \text{p_unit_prc}$$

7.4 Taxes

Taxes are defined in the 'Tax Records' and will be referenced by the ordered products and thereby ordered article (a_tax_id). If tax id is zero, this product is tax free.

The tax records contain an expiration date that defines the start of a new tax value that is also defined in this record.

Formula:

$$\text{tax} = (\text{price} * \text{t_tax_val1}) / 100$$

If expiration date is reached:

$$\text{tax} = (\text{price} * \text{t_tax_val2}) / 100$$

8 Description of trip management

8.1 Handling of several trips

Any number of orders of record type O, combined in trips of record type H, can be transferred to the truck. Each order record may be followed by 0 to n product records of type P.

The operator selects one of the pre-planned trips at the truck. This trip record is duplicated into the return data, filled with the actual data and saved. The internal trip number h_tour_no in the return data starts at 1 and is incremented by 1 at every trip. The internal tour number in the return data is not related with the internal tour number in the planned data. In the office, the correlation of the planned data to the return data is shown in field h_tour_id. If field h_tour_id is empty, it is an unplanned trip. If a planned trip is selected repetitively, field h_tour_id in the return data contains the original information. The field h_tour_id is unique in the planned data, but it may not be unique in the return data.

8.2 Handling of a pseudo-trip with a pool of orders

It is also possible to work with only one (pseudo-) trip with a pool of orders. The office deletes executed orders and adds new orders or modifies existing orders of this pool, but always within this trip. This trip is a pseudo trip and always contains the orders for the next few hours. There is no need to select a trip at the truck. This option is configurable at the truck. Within the return data, the trip data contains the completed orders in chronological sequence, e.g. by day, or by shift, after a driver change.

8.3 Handling of orders

Within a trip 0 to n orders exist. The operator chooses one of the given orders at the truck, this order record is duplicated into the return data and will be filled with the actual processed data and saved. The internal order number o_ord_no within the trip is created in the return data, starts at 1 and is incremented by 1 at every order. The internal order number in the return data is not related to the internal order number in the planned data. In the office, the correlation of the planned data to the return data is shown in the field o_ord_id. If field o_ord_id is empty, it is an unplanned order, which has to be processed manually. If a planned order is selected a second time, e.g. because the first processing was not completed, field o_ord_id in the return data contains the original information. The field o_ord_id is unique in the planned data and may not be unique in the return data. If the field o_ord_id is empty, this order has to be handled manually in the office.

8.4 Handling of products

Within an order, 0 to 99 product records may exist. The operator chooses one of the given product records at the truck. This record is duplicated into the return data, filled with the actual data of the transaction (loading or delivery), and saved. The internal number `p_pos_no` within the order is created in the return data, starts at 1 and is incremented by 1 for every product record. The internal number in the return data is not related with the internal number in the planning data. In the office, the correlation of the planned data to the return data is shown in field `p_pos_id`. If field `p_pos_id` is empty, it is an unplanned product record. If a planned product record is chosen a second time, e.g. because the first time failed, field `p_pos_id` in the return data contains the original information. The field `p_pos_id` is unique in the planned data and may not be unique in the return data. If an order contains unplanned product records or product records which are handled twice, it must be processed in the office.

9 Fields and records of RC_File

A record container (RC) file may contain records of one or more different types.

Fields and records of RC_File according to Table 5

Table 5— Fields and records of RC_File

Index	Fieldname	Data Type	Required	DEST	Description	Detailed description
A-Article						
Goods and service description						
A00	a_deleted	B	X		Cancelled-flag	If this Boolean is set to "1", this record shall be deleted from the list of records on the destination system. If an article record is deleted, all corresponding S records shall be deleted automatically!
A01	a_art_id	C16	PK	T	Unique article identification. primary key.	e.g. SAP product no.
A02	a_art_no	N3	U	T	Short product code number, as defined by the host system	Short product no, used for manual input from driver, e.g. CPDP code
A03	a_art_txt	U30	X	T	Article name	
A04	a_pck_cnt	N4.2		T	Content of packing in unit, as given in #A07 for pricing	
A05	a_ovr_pck	N4			Number of items in overpack	e.g. 20 cans per box (only for information, not used for any calculation)
A06	a_tare_wgh	N5.2		T	Empty weight of packing (in kg)	
A07	a_unit_txt	U6	X	T	Abbreviation of unit of measure (SI units shall be used when applicable)	e.g. 'L', 'kg', 'm³', 'pieces'
A08	a_unit_msr	N1	X	T	Unit of measure	0: litres 1: gallons 2: kilograms 3: cubic metres 4: millimetres 5: hPa 6 pieces See #L1007 of EN 15969-1:2011

Table 5 (continued)

Index	Fieldname	Data Type	Required	DEST	Description	Detailed description
A09	a_pck_txt	U30		T	Packing name	e.g. "Pieces", "Drum",...
A10	a_prc_fac	N4		T	Unit price factor	This factor will typically be 1, 10, 100 or 1000
A11	a_prc_code	N1		T	Price code	This code indicates how to handle 'a_unit_prc' within calculations: 0 = piece, the multiplier for 'p_unit_prc' is field #P14 1 = quantity, the multiplier for 'p_unit_prc' is field #P14 2 = fixed price, the field #P07 'p_unit_prc' is the valid price. No calculations will take place.
A12	a_unit_prc	N5.4		T	Price for unplanned delivery	
A13	a_tax_id	C16		T	Tax reference	links to #T01.
A14	a_met_prod	N3	X	T	Metered product code	0 - all unmetered products 1 to 99 - metered products (met_prod) according to EN 14116
A15	a_add_id	C16		T	Product code of additive that shall be injected	links to #A01.
A16	a_add_ppm	N5		T	Ratio in ppm	Ratio concerning #A14; may be used to set on board injection system
A17	a_sup_id	C16		T	code of supplementary product that might be added	links to #A01. The article referenced may be added when this article is delivered. e.g. deposit, ADR surcharge, see #A18
A18	a_sup_cat	B		T	Category of supplementary product	If an supplementary product is specified in #A17 this field specifies whether it is: 0 – mandatory 1 - optional
A19	a_art_cat	N1		T	Category of product	0 – available product 1 – common product (frequently used) 2 – fixed charge incurred (common supplementary product)

Table 5 (continued)

Index	Fieldname	Data Type	Required	DEST	Description	Detailed description
A20	a_fp_cl	C2		T	Flashpoint classes	A1: flashpoint < 21 °C A2: flashpoint ≥ 21 °C, < 55 °C A3: flashpoint ≥ 55 °C
A21	a_crny_sym	C3		T	Currency symbol	according to ISO 4217, e.g. EUR, GBP, DKK, SEK, ...
A22	a_dens_15c	N4.1		HT	Density at 15°C	kg m ⁻³
A23	a_prt_grs	B		T	Print gross quantity	0 – not print gross quantity, only net quantity 1 - print both, gross and net quantity In accordance with national regulations
A24	a_pid_grd	N3	X		PID - Grade	according to EN 14116, 0 non oil products
A25	a_p_compc	N5	X		Company code	Unique oil company code according to EN 14116 0 not specified > 0 specific company code
A26	a_p_prodc	N10	X		Product code	Company specific unique product code according to EN 14116. 0 not specified > 0 specific product code
A27	a_lead_r	N3		T	Lead rate	mg/l
A28	a_sulphur	N4		T	Sulphur content	Unit PPM
A29	a_lubr	N4		T	Lubricant agent	Unit PPM
A30	a_freez	N4		T	Anti-freezing agent	Unit PPM
A31	a_dye_c	N1		T	Dye code	Dyed product d=0: unknown – don't care d=1: undyed product d=2: dyed product, red

Index	Fieldname	Data Type	Required	DEST	Description	Detailed description
						d=3: dyed product, green d=4: dyed product, blue d=5: dyed product, yellow d=6: dyed product, purple d=7: dyed product, brown
A32	a_dye_r	N3		T	Dye ratio	Unit PPM

Table 5 (continued)

Index	Fieldname	Data Type	Required	DEST	Description	Detailed description
C – Customer						
Customer data						
C00	c_deleted	B	X	T	Cancelled-flag	If this Boolean is set to “1”, this record shall be deleted from the list of records on the destination system. If a customer record is deleted, all corresponding S,N records shall be deleted automatically.
C01	c_cus_id	C16	PK	T	Customer number	
C02	c_loc_id	C16	X	T	Invoice address	links to #L01
C03	c_match	U30		T	Match code	
C04	c_vat	B		T	VAT identification: yes or no	0 = customer shall be charged for VAT 1 = customer is VAT exempted
C05	c_tax_no	C15		T	European community tax identification number	
C06	c_comp_id	N3		HT	Company identification	used for several applications. 0 = default company (setup at truck computer)
C07	c_bra_id	N3		HT	Branch identification	used for several applications. 0 = default branch (setup at truck computer)
C08	c_pay_mode	N1		HT	Payment mode	For description see #O15.

Table 5 (continued)

Index	Fieldname	Data Type	Required	DEST	Description	Detailed description
H – Tour header						
H00	h_deleted	B	X		Cancelled-flag	If this Boolean is set to “1”, this record shall be deleted from the list of records on the destination system. If a trip is deleted, the corresponding O- and P-records shall be deleted automatically!
H01	h_tour_id	C16	U	HT	External tour number	This number shall be unique in the planned data and may not be unique in the return data.
H02	h_tour_no	N6	PK	HT	Internal tour no	links to #O02
H03	h_tourtext	U30		T	Short information about the tour	
H04	h_drv_id	C16	X	HT	Driver identification number	see #R01
H05	h_veh_id	C16	X	HT	Truck ID number	Tractor or rigid vehicle
H06	h_trail_id	C16		HT	Trailer ID	Semi-trailer or draw-bar trailer
H07	h_start_ts	S		HT	Timestamp of trip start	
H08	h_end_ts	S		HT	Timestamp of trip end	
H09	h_veh_reg	C30		HT	Truck's registration number	
H10	h_trai_reg	C30		HT	Trailer's registration number	
H11	h_no_del	N4		HT	Total number of orders	Total account of orders that have to be / have been delivered (number of o-records for this trip)
H12	h_no_err	N4		H	Total numbers of errors	Account of errors that occurred when driving this tour.

Table 5 (continued)

Index	Fieldname	Data Type	Required	DEST	Description	Detailed description
L – Location						
Static: Location data						
L00	I_deleted	B	X	T	Cancelled-flag	If this Boolean is set to “1”, this record shall be deleted from the list of records on the destination system.
L01	I_loc_id	C16	PK	T	Unique location ID	
L02	I_name01	U30		T	Name of customer	
L03	I_name02	U30		T	Name of customer, line 2	
L04	I_name03	U30		T	Name of customer, line 3	
L05	I_housenm	U30		T	House name	e.g. “Medical centre”
L06	I_street	U30		T	Street name	
L07	I_streetno	U10		T	House number	e.g. “2a”
L08	I_area	U30		T	Area	Part of town
L09	I_zipcode	U10		T	Post code	
L10	I_city	U30		T	Name of town	
L11	I_county	U30		T	County, district	
L12	I_state	U30		T	Federal state	
L13	I_cntry	U30		T	Country	
L14	I_cntrycd	C2		T	Country code	Two letter code according to EN ISO 3166-1
L15	I_supplmt	U30		T	Supplement	e.g. “near station”

Table 5 (continued)

Index	Fieldname	Data Type	Required	DEST	Description	Detailed description
L16	l_phone1	U30		T	Phone number	e.g. land line
L17	l_phone2	U30		T	Phone number	e.g. mobile phone
L18	l_fax_no	U30		T	Fax number	
L19	l_email	U30		T	Email address	
L20	l_geo_long	G		T	Longitude	See #L0802 of EN 15969-1:2011. Positive value is east of Greenwich; negative value is west of Greenwich.
L21	l_geo_lat	G		T	Latitude	See #L0803 of EN 15969-1:2011. Positive value is north of equator; negative value is south of equator.
L22	l_geo_hght	N4		T	Altitude	See #L0804 of EN 15969-1:2011. metres above sea level

Table 5 (continued)

Index	Fieldname	Data Type	Required	DEST	Description	Detailed description
L23	l_geo_qlty	N2		T	Geo quality	See #L0805 of EN 15969-1:2011. Quality of position data 0 no position data or unknown quality 1 Matching Postcode only 2 Matching Town only 3 Matching Postcode and Town (uncertain) 4 Matching Postcode and Town (exact match) 5 Matching up to Town district (uncertain) 6 Matching up to Street (uncertain) 7 Matching up to Street No. (uncertain) 8 Matching up to Town District (exact match) 9 Matching up to Street (exact match) 10 Matching up to Street No. (exact match) 11 GPS positioning (unknown quality) 12 Manually assigned in digital map 13 GPS positioning (dead reckoning) 14 GPS positioning (single measurement) 15 GPS positioning (differential) 16 GPS positioning (averaged)
L24	l_max_dst	N8		T	Maximum distance between TVE position and position given by #L20 and #L21	
LR – Location restriction						
Restrictions for a location (time windows, vehicle accessibility, permitted actions)						
LR00	lr_deleted	B	X	T	Cancelled-flag	If this Boolean is set to “1”, this record shall be deleted from the list of records on the destination system.
LR01	lr_loc_id	C16	PK	T	Unique location ID	links to #L01

Table 5 (continued)

Index	Fieldname	Data Type	Required	DEST	Description	Detailed description
LR02	lr_stat_ok	N1		T	geofencing 0 use TVE defaults 1 manual override by OBC 2 correct position detected by OBC	See Table 9 of EN 15969-1:2011.
LR03	lr_stat_ty	N1		T	0 tank vehicle 1 gantry 2 refinery 3 workshop 4 service station 5 client 6 trailer	See Table 9 of EN 15969-1:2011.
LR04	lr_op_flg	H1		T	Permitted operations Bit0: discharge permitted Bit1: loading permitted Bit2: service functions permitted (e.g. workshop)	See Table 9 of EN 15969-1:2011.

Table 5 (continued)

Index	Fieldname	Data Type	Required	DEST	Description	Detailed description
LR05	lr_bypass	H2		T	Explicit allowed bypass Bit0: magnetic product code Bit1: electrical product code (PID according to EN 14116) Bit2: overfill protection system assignment Bit3: vapour recovery hose assignment Bit4: overfill protection system present Bit5: vapour recovery hose present Bit6: hose supervision system present	See Table 9 of EN 15969-1:2011.
LR06	lr_defbyp	H2		T	Shall be bypassed for this location List according to #LR05	See Table 9 of EN 15969-1:2011.
LR07	lr_nevbyp	H2		T	May in no case be bypassed List according to #LR05	See Table 9 of EN 15969-1:2011.
LR08	lr_tw1_beg	S		T	Time window 1: Begin	
LR09	lr_tw1_end	S		T	Time window 1: End	
LR10	lr_tw1_dow	H2		T	Time window 1: Day of Week	SUN=6, SAT=5, FRI=4, THU=3, WED=2, TUE=1, MON=0
LR11	lr_tw2_beg	S		T	Time window 2: Begin	
LR12	lr_tw2_end	S		T	Time window 2: End	
LR13	lr_tw2_dow	H2		T	Time window 2: Day of week	SUN=6, SAT=5, FRI=4, THU=3, WED=2, TUE=1, MON=0

Table 5 (continued)

Index	Fieldname	Data Type	Required	DEST	Description	Detailed description
LR14	lr_veh_size	N2		T	Max. vehicle size	
LR15	lr_hose_lg	N2		T	Necessary hose length	In metres. Truck delivering this order position shall have a hose at least this long.
LR16	lr_prep_tm	N4		T	Additional time in minutes	
LR17	lr_trailer	B		T	Trailer allowed	
LR18	lr_trk_col	N2		T	Desired vehicle colour	
N – Notes						
Arbitrary dynamic notes for any object						
N00	n_deleted	B	X	T	Cancelled-Flag	If this Boolean is set to “1”, this record shall be deleted from the list of records on the destination system
N01	n_ref_obj	C2	PK	T	specifies type of referenced record	e.g. “A”, “O”, “P”, ...
N02	n_obj_id	C16	PK	T	referenced object ID	e.g. content of o_ord_id if an O record is the referenced object
N03	n_seq_no	N2	PK	T	Reference No, identifies a note	e.g. this is note “No. 1” for this order
N04	n_note	U30	X	T	Text string	
O – Order record						
O00	o_deleted	B	X	T	Cancelled-Flag	If this Boolean is set to “1”, this record shall be deleted from the list of records on the destination system. If an order is deleted, the corresponding P, S, N and OR-records shall be deleted automatically!
O01	o_ord_id	C16	U	HT	Order number	Order number from host system. This number shall be unique in the planned data and may not be unique in the return data.
O02	o_tour_no	N6	PK	HT	Trip ID	links to #H01.

Table 5 (continued)

Index	Fieldname	Data Type	Required	DEST	Description	Detailed description
O03	o_ord_no	N6	PK	HT	Internal order number	Internal order number for reference between order and items of the order.
O04	o_pos_no	N2	X	HT	Number of products in this order	Sends and returns the number of valid entries in the 'Ordered Product Database' for this order, including unplanned products.
O05	o_cus_id	C16	X	HT	Customer/depot/refinery number	links to #C01
O06	o_ca_id	C16			Contact person	links to #L01
O07	o_da_id	C16	X		Delivery address	links to #L01
O08	o_comp_id	N3		HT	Company identification	used for several applications. 0 = default company (setup at truck computer)
O09	o_bra_id	N3		HT	Branch identification	used for several applications. 0 = default branch (setup at truck computer)
O10	o_cord_no	U30		HT	Customer order number	Order number given by customer
O11	o_rcpt_id	N1		HT	Kind of receipt	0 = delivery note without price 1 = delivery note with price 2 = invoice.
O12	o_cpy_amnt	N1		HT	Amount (number) of copies	Amount of documents (delivery notes/invoices) to be printed after issuing the printout interaction of the operator. More than these copies can be initialized by the operator (depends on truck system).

Table 5 (continued)

Index	Fieldname	Data Type	Required	DEST	Description	Detailed description
O13	o_inv_no	N6		HT	Invoice number	Sequence number of the invoice. If only a delivery note is printed, this field is returned empty to the host.
O14	o_del_no	N6		HT	Delivery note number	Sequence number of the delivery note. If only an invoice and no delivery note was printed, this field is returned empty to the host.
O15	o_pay_mode	N1		HT	Payment mode	At the beginning of the delivery a message shall inform the operator of how the customer should pay. This opens the possibility to interrupt the delivery e.g. in the case that the customer is not able to pay. 0 = no 1 = cash 2 = cheque 3 = credit card 4 = remittance slip 5 = direct debit
O16	o_sum_net1	N6.2		H	Net amount tax 1	
O17	o_tax_amt1	N6.2		H	Tax 1 amount	
O18	o_sum_net2	N6.2		H	Net amount tax 2	
O19	o_tax_amt2	N6.2		H	Tax 2 amount	
O20	o_sum_net3	N6.2		H	Net amount no tax	These fields contain all necessary amounts to validate the invoice.
O21	o_del_strt	S		H	Delivery start: date and time	
O22	o_del_end	S		H	Delivery end: date and time	

Table 5 (continued)

Index	Fieldname	Data Type	Required	DEST	Description	Detailed description												
O23	o_lyt_id	N2		T	Printer layout identification	0 = standard layout >1 = number of layout to be used												
O24	o_lng_id	C2		T	Language identification	ID of language according to ISO 639-1 to use for this order												
O25	o_crny_sym	C3		HT	Currency symbol	according to ISO 4217, e.g. EUR, DKR ...												
O26	o_pmt_date	S		HT	Payment date													
O27	o_pmt_term	N2		T	Payment terms	Used on printout to calculate the payment term <table border="0" style="margin-left: 20px;"> <tr> <td>o_pmt_date</td> <td>o_pmt_term</td> <td>when to pay</td> </tr> <tr> <td>D</td> <td>-</td> <td>due on date D</td> </tr> <tr> <td>0</td> <td>X</td> <td>delivery date + X days</td> </tr> <tr> <td>0</td> <td>0</td> <td>immediate</td> </tr> </table>	o_pmt_date	o_pmt_term	when to pay	D	-	due on date D	0	X	delivery date + X days	0	0	immediate
o_pmt_date	o_pmt_term	when to pay																
D	-	due on date D																
0	X	delivery date + X days																
0	0	immediate																

Table 5 (continued)

Index	Fieldname	Data Type	Required	DEST	Description	Detailed description
O28	o_del_stat	N2			Delivery status	This field indicates the break reasons. This content may effect a force printout of a delivery note. 0 = completed delivery 1 = customer not present 2 = no demand 3 = no money (-> #O15) 4 = technical disturbance on truck 5 = technical disturbance at customer 6 = dispatcher order 7 = truck empty
O29	o_drv_id	C16		T	Driver ID	links to #R01 only necessary, if driver changes within trip.
O30	o_sum_paid	N6.2		H	Amount paid by the customer to the driver	
O31	o_pay_stat	N1		H	Payment state	
O32	o_proc_id	N2	X	HT	Process identification	0=delivery at customer 1=loading from customer 2=loading from depot 3=delivery at depot 4=loading from refinery 5=delivery at refinery 6 = dip only (no product order, but only used to force the driver to dip the tank and enter the result into the OBC)

Table 5 (continued)

Index	Fieldname	Data Type	Required	DEST	Description	Detailed description
OR – Order restrictions						
Delivery restrictions and time windows						
OR00	or_deleted	B	X	T	Cancelled-flag	If this Boolean is set to “1”, this record shall be deleted from the list of records on the destination system.
OR01	or_ord_id	C16	PK	T	Reference to order	links to #O01
OR02	or_prep_tm	N4		T	Additional time in minutes	
OR03	or_trailer	B		T	Trailer allowed	
OR04	or_veh_size	N2		T	Max. vehicle size	
OR05	or_trk_col	N2		T	Desired vehicle colour	
OR06	or_sel_drv	C16			Preferred driver	links to #R01
OR07	or_sel_trk	C16			Preferred vehicle	
OR08	or_sel_dep	C16		T	Preferred depot	links to #C01
OR09	or_sel_tou	C16		T	Preferred standard trip	
OR10	or_fr_rate	N6.2		T	Order specific freight rate	
OR11	or_byg_id	C16		T	Buying group ID	
OR12	or_byg_nm	U30		T	Name of buying group	
OR13	or_byg_seq	C5		T	Seq. No. within BG	
OR14	or_blocked	B		T	Order type: can be planned / not be planned	0: can be planned 1: cannot be planned
OR15	or_domain	C16		T	Order domain: specifies the domain (e.g. area) the order belongs to	e.g. "SOUTH", "NORTH", etc.
OR16	or_tw1_beg	S		T	Time window 1: Begin	

Table 5 (continued)

Index	Fieldname	Data Type	Required	DEST	Description	Detailed description
OR17	or_tw1_end	S		T	Time window 1: End	
OR18	or_tw1_dow	H2		T	Time window 1: Day of Week	SUN=6, SAT=5, FRI=4, THU=3, WED=2, TUE=1, MON=0
OR19	or_tw2_beg	S		T	Time window 2: Begin	
OR20	or_tw2_end	S		T	Time window 2: End	
OR21	or_tw2_dow	H2		T	Time window 2: Day of Week	SUN=6, SAT=5, FRI=4, THU=3, WED=2, TUE=1, MON=0
OR22	or_tw3_beg	S		T	Time window 3: Begin	
OR23	or_tw3_end	S		T	Time window 3: End	
OR24	or_tw3_dow	H2		T	Time window 3: Day of week	SUN=6, SAT=5, FRI=4, THU=3, WED=2, TUE=1, MON=0
OR25	or_tw4_beg	S		T	Time window 4: Begin	
OR26	or_tw4_end	S		T	Time window 4: End	
OR27	or_tw4_dow	H2		T	Time window 4: Day of week	SUN=6, SAT=5, FRI=4, THU=3, WED=2, TUE=1, MON=0
P – Order Lines						
P00	p_deleted	B	X	T	Cancelled-flag	If this Boolean is set to “1”, this record shall be deleted from the list of records on the destination system.
P01	p_pos_id	C16	U	HT	External unique ID	This number shall be unique in the planned data and may not be unique in the return data.
P02	p_tour_no	N6	PK	HT	Tour ID	links to #H02
P03	p_ord_no	N6	PK	HT	Internal order number	links to #O03
P04	p_pos_no	N2	PK	HT	Internal order line counter	Numbers the order lines within one order from 1 to 99.
P05	p_art_id	C16	X	T	Article identification	links to #A01
P06	p_ord_amt	N5.2	X	T	Ordered amount (volume, weight, pieces)	Amount of volume ordered in accordance with the compensation temperature. Type of compensation can be reported by data field P16 and P17.

Table 5 (continued)

Index	Fieldname	Data Type	Required	DEST	Description	Detailed description
P07	p_unit_prc	N5.4		T	Price per unit (pieces or amount)	The price is calculated by the volume of the product. It is also possible to use a fixed price (p_prc_code=2). The fixed price is independent to the delivered quantity. Price calculations are inhibited. The fixed price is always a net price. Tax calculation is not inhibited.
P08	p_low_vol1	N5		T	Quantity for surcharging 1	
P09	p_sur_vol1	N5.2		HT	Surcharge 1	
P10	p_low_vol2	N5		T	Quantity for surcharging 2	
P11	p_sur_vol2	N5.2		HT	Surcharge 2	
P12	p_low_vol3	N5		T	Quantity for surcharge 3	This fields are used to calculate surcharges. If the quantity is between 'p_low_vol1' and 'p_low_vol2', 'p_sur_vol1' shall be used for calculations. If the quantity is between 'p_low_vol2' and 'p_low_vol3', 'p_sur_vol2' shall be taken for calculations. Below 'p_low_vol3' the calculation of the complete delivery shall stopped. Invoice is automatically turned to delivery note.
P13	p_sur_stat	N1		HT	Surcharge status	This status indicates which surcharge is used. 0 = no surcharge 1 = surcharge 1 2 = surcharge 2 3 = surcharge 3
P14	p_del_qty	N6.2		H	Actual delivered quantity	Same unit as specified in #P15. If the unit was 'pieces', the details on the delivered packaging can be found in #A04.

Table 5 (continued)

Index	Fieldname	Data Type	Required	DEST	Description	Detailed description
P15	p_unit_msr	N1		H	This is the unit that has been used by the truck. May differ from the unit that this product is normally sold in (#A08). Shall be filled when sent from truck.	0: litres 1: gallons 2: kilograms 3: cubic metres 4: millimetres 5: hPa 6 pieces See #L1007 of EN 15969-1:2011
P16	p_tempcomp	B		H	Volume has been temperature compensated.	0: not compensated 1: compensated
P17	p_base_tmp	N2		H	Base temperature to use for compensation	In degrees Celsius
P18	p_del_stat	N1		H	Delivery status	If there are quantities and/or products that were not delivered, there should be a code number for the reason: 0 = completely delivered 1 = truck empty 2 = customer tank full 3 = technical disturbance.
P19	p_vol_grs	N6.2		H	Uncompensated total volume	Same unit as specified in #P15
P20	p_avg_tmp	N4.1		H	Average temperature with sign, e.g. +025,1	
P21	p_vol_comp	N6.2		H	Compensated volume at base temperature	Compensated at temperature given in #P17 Same unit as specified in #P15
P22	p_del_wght	N8.2		H	Delivered weight in kilogram	Only calculated value
P23	p_dens_15c	N4.1		H	Density at 15°C	The measured density is returned.

Table 5 (continued)

Index	Fieldname	Data Type	Required	DEST	Description	Detailed description
P24	p_rcpt_no	N6		H	Receipt number of electronic counter head	
P25	p_ctrct_no	C15		HT	Contract number	Host: Contract No. to use Truck: Will be returned if loaded/delivered to/from depot/refinery
P26	p_cntr_no	C16		H	Counter number	Number of electronic counter head.
P27	p_cpt_no	H4		HT	Compartment number	Sends the compartment proposal to the truck computer and the used compartment back to the host. List of compartments with a bit pattern. 1 represents compartment 1 and so on.
P28	p_tnk_loc	N2		HT	Tank location on station	
P29	p_tnk_shp	C5		T	Tank type code	Description of tank. Code includes max. tank content.
P30	p_tnkctntb	N6.2		H	Tank content before delivery	
P31	p_tnk_unit	N1		HT	Tank measurement unit identifier	See #P30 and #P32 0 = cm 1 = l
P32	p_tnkctnta	N6.2		H	Tank content after delivery	
P33	p_hose_lg	N2		T	Necessary hose length	In metres. Truck delivering this order position shall have a hose at least this long.
P34	p_pmp_rate	N2		TH	Maximum pumping rate	In litres per minute. Truck's pump rate power shall be reduced to this value while delivering this order position
P35	p_pumped	B		HT	0 = unpumped; 1 = pumped	Reference to EN 15969-1– existing field “transaction”
P36	p_art_type	N2		T	Type of product order	0 - delivery mandatory, no decision to be made 1 - proposal to operator, may chose to deliver or not
P37	p_sup_id	C16		T	Code of supplementary product that might be added	See #A17.

Table 5 (continued)

Index	Fieldname	Data Type	Required	DEST	Description	Detailed description
P38	p_sup_cat	B		T	Category of supplementary product	See #A18.
P39	p_art_cat	N1		T	Category of product	See #A19.
R – Driver						
Driver data						
R00	r_deleted	B	X	T	Cancelled-Flag	If this Boolean is set to “1”, this record shall be deleted from the list of records on the destination system.
R01	r_drv_id	C16	PK	T	Driver ID	
R02	r_drv_name	U30	X	T	Driver name	
R03	r_lng_id	C2		T	Code of language to be used for user interface of OBC and other truck equipment	Same definition as #O25
R04	r_auth_lvl	N1		T	Driver authorisation level	0 acceptable 1 not acceptable
R05	r_drv_pin	N6		T	PIN code of driver	
S – Text-module reference						
Static texts for any object						
S00	s_deleted	B	X	T	Cancelled-flag	If this Boolean is set to “1”, this record shall be deleted from the list of records on the destination system.
S01	s_ref_obj	C2	PK	T	Specifies type of referenced record	e.g. “A”, “O”, “P”, ...
S02	s_obj_id	C16	PK	T	Referenced object ID	e.g. content of o_ord_id if an O record is the referenced object
S03	s_txt_id	R	X	T	Reference to text module	links to #X01
S04	s_seq_no	N2	PK	T	Reference No, identifies a text module reference.	e.g. this is text module “No. 1” for this order

Table 5 (continued)

Index	Fieldname	Data Type	Required	DEST	Description	Detailed description
T – Tax						
Tax data						
T00	t_deleted	B	X	T	Cancelled-flag	If this Boolean is set to “1”, this record shall be deleted from the list of records on the destination system.
T01	t_tax_id	C16	PK	T	Tax reference number	
T02	t_tax_val1	N2.2	X	T	Actual tax value in percent	
T03	t_exp_date	S	X	T	Expiration date (timestamp)	Expiration date of #T02. If #T03 is empty, no limit is in use.
T04	t_tax_val2	N2.2	X	T	New tax value in percent	
T05	t_calc_id	N1		T	Calculation method	0 = VAT on totals 1 = VAT on each item
X – Text Modules						
Static: Text modules used for print-out						
X00	x_deleted	B	X	T	Cancelled-flag	If this Boolean is set to “1”, this record shall be deleted from the list of records on the destination system.
X01	x_blk_id	N4	PK	T	Text module ID	Each text module may exist in several languages, i.o.w., the combination of #X01 and #X02 shall be unique.
X02	x_lang_id	C2	PK	T	Language ID	Same definition as #O25
X03	x_text	U70	X	T	Textstring	
Y – Annotations						
Arbitrary annotations to any of the above records						
Y00	y_deleted	B	X	T	Cancelled-flag	If this Boolean is set to “1”, this record shall be deleted from the list of records on the destination system.
Y01	y_ann_obj	C2	PK	T	Specifies type of referenced record	e.g. “A”, “O”, “P”, ...

Table 5 (continued)

Index	Fieldname	Data Type	Required	DEST	Description	Detailed description
Y02	y_obj_id	C16	PK	T	Referenced object ID	e.g. content of o_ord_id if an O record is the referenced object
Y03	y_ann_key	C30	PK	T	Key	An annotation always consists of a key/value pair. This is the "key" part.
Y04	y_ann_val	U30	X	T	Value	An annotation always consists of a key/value pair. This is the "value" part.
PK: Primary Key: required, unique U: required, unique X: required						

10 Multi-Order Data (Subnode RC_FILE)

10.1 General

The node FTL,ORDER is only suitable for handling single orders and is limited to metering data. If more than one order and/or commercial data e.g. pricing needs to be exchanged the FTL node "RC_FILE" shall be used. It may contain:

- multiple orders (batch processing);
- pricing;
- master data (e.g. products, customers, drivers, taxes, vehicles);
- additional texts for the printout;
- information for the drivers;
- trip management;
- data for invoicing with surcharge or discharge;
- Data for delivery of packaged goods;
- FTL Batch commands.

Adding or updating orders by the client shall be possible except orders already processed or in process.

10.2 Node RC_File

Setting orders and all related information by RC_FILE

Variable	FTL,RC_FILE,Content=V
Kind	List, write only, optional
Set	Append a record (V)

Variable	FTL,RC_FILE
Kind	Value, write, optional
Clear	Erases all planned H-,O-,P-records and all related N-,S-,Y- and OR-records.

Variable	FTL,n_FILE (n = A, C, L, R, T or X)
Kind	Value, write, optional
Clear	Erases all records of the given type including all related N- and S-records. Erasing L_FILE shall delete all location records and the related LR location restriction records.

Return processed orders by RC_FILE,Result

Variable	FTL,RC_FILE,Result
Kind	List, read only, optional
Enquiry	Retrieve processed order data depending on node "RC_FILE,ResultMode"
Clear	Delete processed order data depending on node "RC_FILE,ResultMode"

Variable RC_FILE,ResultMode

Variable	FTL,RC_FILE,ResultMode
Kind	Value, read/write, optional
Set	Set the filter type for node "RC_FILE,Result"
Value V	0 Read last order. 1 Read all processed orders. 2 Read all processed and yet unread orders.

10.3 Information concerning application

10.3.1 Simple trip plan, using FTL connection

Using an on-line connection, the following sequence of commands creates a new trip plan and updates any of the static database files with the records needed to process the orders in H, O and P data files.

The commands may be issued by the OBC, using order data received from the back office, or directly from the back office by an own client, using FTL channel 2. Examples are given in Table 6.

Table 6 — Trip plan data (FTL connection)

Client request (server response omitted)	Comment
CLR,FTL,RC_FILE	Delete any previous orders (only H, O and P files and all related N-, S-, Y- and OR-records), will not effect static data like articles, locations,...
SET,FTL,RC_FILE,CONTENT=A,0,A00001,1,heating oil,.... SET,FTL,RC_FILE,CONTENT=A,0,A00179,7,odourless heating oil,...	If article numbers A00001, respectively A00179 exist, the existing records will be superseded, otherwise the database will be amended.
SET,FTL,RC_FILE,CONTENT=L,0,,AD0782,Mayer,,, ...	Create/supersede Address record AD0782 (needed for customer entry CU0782).
SET,FTL,RC_FILE,CONTENT=C,0,CU0782,AD0782,May,,, ...	Create/supersede customer record CU0782 (needed for subsequent order T1101).

Table 6 (continued)

Client request (server response omitted)	Comment
SET,FTL,RC_FILE,CONTENT=C,1,CU0103,...	Erase customer record CU0103 (for whatever reason).
SET,FTL,RC_FILE,CONTENT=...	Any additional database records which may be needed for the subsequent orders (text, locations,...).
SET,FTL,RC_FILE,CONTENT=H,0,11,TRIP11,Morning trip,...	First trip
SET,FTL,RC_FILE,CONTENT=O,0,11,1,2,0,0,T11O1,CU0782,...	First order of first trip
SET,FTL,RC_FILE,CONTENT=P,0,11,1,1,T11O1P1,A00001,7000,....	First ordered product in first order
SET,FTL,RC_FILE,CONTENT=P,0,11,1,2,T11O1P2,A03793,1,...	2 nd order, e.g. additive can
SET,FTL,RC_FILE,CONTENT=O,0,11,2,1,0,0,T11O2,CU0911,...	Second order in first trip, one article
SET,FTL,RC_FILE,CONTENT=P,0,11,2,1,T11O2P1,A00179,3000,....	Article ordered in second order
SET,FTL,RC_FILE,CONTENT=H,0,12,TRIP12,Afternoon,...	Second trip
SET,FTL,RC_FILE,CONTENT=O,0,12,1,1,0,0,T12O1,CU1328,...	First order in second trip
SET,FTL,RC_FILE,CONTENT=P,0,12,1,1,T12O1P1,A00179,2000,....	Only one article ordered
<EOT>	Will trigger processing of this RC_file

Assuming that only trip 11 and order 1 of this trip has been processed, and one additional unplanned order has been delivered during the first trip, return data may appear as shown in Table 7.

Table 7 — Trip return data (FTL connection)

Server response to client requests "REQ,RC_FILE,RESULT"	Comment
REP,FTL,RC_FILE,RESULT=H,0,11,1,TRIP11,,7,107,...	Driver 7, truck 107 did trip 11
REP,FTL,RC_FILE,RESULT=O,0,11,1,2,0,0,T11O1,CU0782,...	Customer Mayer, as planned
REP,FTL,RC_FILE,RESULT=P,0,11,1,1,T11O1P1,A00001,7000,...	Heating oil order, as planned
REP,FTL,RC_FILE,RESULT=P,0,11,1,2,,A03792,,,,,,,,,2,...	Two smaller can have been delivered instead of A03793. Marked as unplanned.
REP,FTL,RC_FILE,RESULT=O,0,11,2,1,0,0,,CU0083,...	Unplanned order to customer contained in customer database
REP,FTL,RC_FILE,RESULT=P,0,11,2,1,,A00179,....	Unplanned delivery of odourless heating oil to this customer

10.3.2 Simple Trip Plan, Using FTP and RC_FILE

When no online connection is available, order data may also be transferred from the back office to the OBC using an FTP connection.

In regular intervals, or triggered by a driver command, or by an FTL command received, the OBC may establish an FTP connection and:

- scan the in folder of its home directory for order data;
- transfer return data (of the trips already done) to the out folder of the home directory.

If a file named RC_CCYYMMDDhhmmss .FTL is found on the in directory, the same trip plan as above may be contained in Table 8.

To reduce data transfer times, data files may be compressed. For this compression the ZIP-format shall be used and the file name shall be RC_CCYYMMDDhhmmss .ZIP.

Table 8 — Trip plan data (FTP connection)

File content	Comment
A,0,A00001,1,Heating Oil,... A,0,A00179,7,NoSmell Heating Oil,...	If article numbers A00001, respectively A00179 exist, the existing records will be superseded, otherwise the database will be amended.
L,0,AD0782,Mayer,,, ...	Create/supersede address record AD0782 (needed for customer entry CU0782).
C,0,CU0782, AD0782,May,,, ...	Create/supersede customer record CU0782 (needed for subsequent order T11O1).
C,1,CU0103,...	Erase customer record CU0103 (for whatever reason).
...	Any additional database records which may be needed for the subsequent orders (text, locations,...).
H,0,11,TRIP11,Morning trip,...	First trip
O,0,11,1,2,0,0,T11O1,CU0782,...	First order of first trip
P,0,11,1,1,T11O1P1,A00001,7000,...	First ordered product in first order
P,0,11,1,2,T11O1P2,A03793,1,...	2 nd order, e.g. additive can
O,0,11,2,1,0,0,T11O2,CU0911,...	Second order in first trip, one article
P,0,11,2,1,T11O2P1,A00179,3000,...	Article ordered in second order
H,0,12,TRIP12,Afternoon,...	Second trip
O,0,12,1,1,0,0,T12O1,CU1328,...	First order in second trip
P,0,12,1,1,T12O1P1,A00179,2000,...	Only one article ordered
<EOT>	Will trigger processing of this RC_file

Upon the next FTP connection, the following result file will be transferred to a file named RC_CCYYMMDDhhmmss .FTL in the out folder, assuming the same trip events as in the example above. Examples are given in Table 9.

Table 9 — Trip return data (FTP connection)

File content	Comment
H,0,11,TRIP11,,7,107,...	Driver 7, truck 107 did trip 11
O,0,11,1,2,0,0,T11O1,CU0782,...	Customer Mayer, as planned
P,0,11,1,1,T11O1P1,A00001,7000,...	Heating oil order, as planned
P,0,11,1,2,,A03792,,,,,,,,,2,...	Two smaller can have been delivered instead of A03793. Marked as unplanned.
O,0,11,2,1,0,0,,CU0083,...	Unplanned order to customer contained in customer database
P,0,11,2,1,,A00179,...	Unplanned delivery of odourless heating oil to this customer

H,O,P records for return data shall be in logical sequence, e.g. H,O,P,P,O,P,P,P,O,H,O,P,O,P,O,P,P or H,H,H,O,O,O,P,P,P,P

10.3.3 Managing static data, using FTL connection

Keeping the static data (articles, addresses, customers,...) up to date is a challenge.

When a mirror image of the TVE data structures is kept in the back office, it may be possible to maintain the data on the TVE, using the update and delete functions given in the examples above.

However, when a TVE shall be initialised, it may be necessary to perform a complete update of a database file.

Using an FTL connection, setting up an entirely new article and customer database, for example, may be done by the FTL commands shown in Table 10.

Table 10 — Static data management (FTL connection)

Client request (server response omitted)	Comment
CLR,FTL,A_FILE	Erase all article records.
CLR,FTL,C_FILE	Erase all customer records.
SET,FTL,RC_FILE,CONTENT=A,0,A00001,...	Start filling the article database.
SET,FTL,RC_FILE,CONTENT=A,0,A00002,...	
....	
SET,FTL,RC_FILE,CONTENT=C,0,CU0001,AD0001,Smith,....	Start filling the customer database.
SET,FTL,RC_FILE,CONTENT=C,0,CU0002,AD0002,Myers,....	
....	

10.3.4 Managing static data under FTP

When the same method is to be used through an FTP connection, FTL Batch commands as specified in 9.3.3 of EN 15969-1:2011 may be embedded in the RC_FILE, using the reserved prefix "FB" to mark these commands shown in Table 11.

Table 11 — Static data management (FTP connection)

File content	Comment
FB,ECLR,FTL,A_FILE	FTL Batch command: clear address database file
FB,ECLR,FTL,C_FILE	FTL Batch command: clear customer database file
A,0,A00001,1,Heating Oil,.... A,0,A00002,2,Diesel,....	Start filling the article database.
C,0,CU0001,AD0001,Smith,.... C,0,CU0002,AD0002,Myers,.....	Start filling the customer database.
...	Other updating may be performed.
H,0,11,TRIP11,Morning trip,,.... O,0,	Data of first trip

The success of the operation may be checked using the result file RC_CCYYMMDDhhmmss .FTL, in which the result data shall be embedded as given in Table 12.

Table 12 — Static data management (confirmation file)

File content	Comment
FB,ECLR,FTL,A_FILE FB,a	FTL Batch command: echo the original command and acknowledgement of this command
FB,ECLR,FTL,C_FILE FB,a	Echo the command to clear customer database file and the acknowledge message.
H,0,11,TRIP11, ...	Following are the data of the first trip...

British Standards Institution (BSI)

BSI is the national body responsible for preparing British Standards and other standards-related publications, information and services.

BSI is incorporated by Royal Charter. British Standards and other standardization products are published by BSI Standards Limited.

About us

We bring together business, industry, government, consumers, innovators and others to shape their combined experience and expertise into standards-based solutions.

The knowledge embodied in our standards has been carefully assembled in a dependable format and refined through our open consultation process. Organizations of all sizes and across all sectors choose standards to help them achieve their goals.

Information on standards

We can provide you with the knowledge that your organization needs to succeed. Find out more about British Standards by visiting our website at bsigroup.com/standards or contacting our Customer Services team or Knowledge Centre.

Buying standards

You can buy and download PDF versions of BSI publications, including British and adopted European and international standards, through our website at bsigroup.com/shop, where hard copies can also be purchased.

If you need international and foreign standards from other Standards Development Organizations, hard copies can be ordered from our Customer Services team.

Subscriptions

Our range of subscription services are designed to make using standards easier for you. For further information on our subscription products go to bsigroup.com/subscriptions.

With **British Standards Online (BSOL)** you'll have instant access to over 55,000 British and adopted European and international standards from your desktop. It's available 24/7 and is refreshed daily so you'll always be up to date.

You can keep in touch with standards developments and receive substantial discounts on the purchase price of standards, both in single copy and subscription format, by becoming a **BSI Subscribing Member**.

PLUS is an updating service exclusive to BSI Subscribing Members. You will automatically receive the latest hard copy of your standards when they're revised or replaced.

To find out more about becoming a BSI Subscribing Member and the benefits of membership, please visit bsigroup.com/shop.

With a **Multi-User Network Licence (MUNL)** you are able to host standards publications on your intranet. Licences can cover as few or as many users as you wish. With updates supplied as soon as they're available, you can be sure your documentation is current. For further information, email bsmusales@bsigroup.com.

BSI Group Headquarters

389 Chiswick High Road London W4 4AL UK

Revisions

Our British Standards and other publications are updated by amendment or revision.

We continually improve the quality of our products and services to benefit your business. If you find an inaccuracy or ambiguity within a British Standard or other BSI publication please inform the Knowledge Centre.

Copyright

All the data, software and documentation set out in all British Standards and other BSI publications are the property of and copyrighted by BSI, or some person or entity that owns copyright in the information used (such as the international standardization bodies) and has formally licensed such information to BSI for commercial publication and use. Except as permitted under the Copyright, Designs and Patents Act 1988 no extract may be reproduced, stored in a retrieval system or transmitted in any form or by any means – electronic, photocopying, recording or otherwise – without prior written permission from BSI. Details and advice can be obtained from the Copyright & Licensing Department.

Useful Contacts:

Customer Services

Tel: +44 845 086 9001

Email (orders): orders@bsigroup.com

Email (enquiries): cservices@bsigroup.com

Subscriptions

Tel: +44 845 086 9001

Email: subscriptions@bsigroup.com

Knowledge Centre

Tel: +44 20 8996 7004

Email: knowledgecentre@bsigroup.com

Copyright & Licensing

Tel: +44 20 8996 7070

Email: copyright@bsigroup.com



...making excellence a habit.™