

**Railway applications
— Closing and locking
devices for payload
protecting devices
against environmental
influences —
Requirements
for durability,
operation, indication,
maintenance, recycling**

ICS 45.060.20

National foreword

This British Standard is the UK implementation of EN 15723:2010.

The UK participation in its preparation was entrusted to Technical Committee RAE/1/-/9, Railway Applications - Wagons (Tank/Freight).

"Normative" - A (mandatory) requirement defined as an "expression in the content of a document conveying criteria to be fulfilled if compliance with the document is to be claimed and from which no deviation is permitted" [CEN/CENELEC Internal Regulations, Part 3: Rules for the Structure and Drafting of European Standards (PNE-Rules)].

"Informative" - Information (not mandatory) intended to assist the understanding or use of the document. Informative annexes shall not contain requirements, except as optional requirements. (For example, a test method that is optional may contain requirements but there is no need to comply with these requirements to claim compliance with the document.

A list of organizations represented on this committee can be obtained on request to its secretary.

This publication does not purport to include all the necessary provisions of a contract. Users are responsible for its correct application.

Compliance with a British Standard cannot confer immunity from legal obligations.

This British Standard was published under the authority of the Standards Policy and Strategy Committee on 30 June 2010

© BSI 2010

ISBN 978 0 580 59954 5

Amendments/corrigenda issued since publication

Date	Comments

EUROPEAN STANDARD

EN 15723

NORME EUROPÉENNE

EUROPÄISCHE NORM

January 2010

ICS 45.060.20

English Version

**Railway applications - Closing and locking devices for payload
protecting devices against environmental influences -
Requirements for durability, operation, indication, maintenance,
recycling**

Applications ferroviaires - Dispositifs de fermeture et de
verrouillage des équipements de protection du chargement
contre les influences environnantes - Exigences de
résistance mécanique, exploitation, marquage,
maintenance et recyclage

Bahnanwendungen - Verschluss- und Sicherungsteile von
Ladegutschutzeinrichtungen gegen Umwelteinflüsse -
Anforderungen an Festigkeit, Bedienbarkeit,
Kennzeichnung, Instandhaltung, Entsorgung

This European Standard was approved by CEN on 7 November 2009.

CEN members are bound to comply with the CEN/CENELEC Internal Regulations which stipulate the conditions for giving this European Standard the status of a national standard without any alteration. Up-to-date lists and bibliographical references concerning such national standards may be obtained on application to the CEN Management Centre or to any CEN member.

This European Standard exists in three official versions (English, French, German). A version in any other language made by translation under the responsibility of a CEN member into its own language and notified to the CEN Management Centre has the same status as the official versions.

CEN members are the national standards bodies of Austria, Belgium, Bulgaria, Croatia, Cyprus, Czech Republic, Denmark, Estonia, Finland, France, Germany, Greece, Hungary, Iceland, Ireland, Italy, Latvia, Lithuania, Luxembourg, Malta, Netherlands, Norway, Poland, Portugal, Romania, Slovakia, Slovenia, Spain, Sweden, Switzerland and United Kingdom.



EUROPEAN COMMITTEE FOR STANDARDIZATION
COMITÉ EUROPÉEN DE NORMALISATION
EUROPÄISCHES KOMITEE FÜR NORMUNG

Management Centre: Avenue Marnix 17, B-1000 Brussels

Contents

Page

Foreword.....	3
Introduction	4
1 Scope	5
2 Normative references	5
3 Terms and definitions	5
4 Requirements	7
4.1 General.....	7
4.2 Strength of side doors and their locking devices, sliding doors and single and multi-leafed doors under transverse loading	8
4.3 Strength of sliding walls and their locking devices	8
4.4 Forces resulting from the passing of trains	8
4.4.1 General.....	8
4.4.2 Movable roofs.....	8
4.4.3 Side doors of high-sided open wagons and their closing and locking devices	8
4.4.4 Unloading doors of gravity discharge wagons and their closing and locking devices	8
4.5 Safeguards of movable protecting devices (i.e. doors, sliding walls, sliding roofs, flaps, hoods)	9
4.6 Verification of durability and functioning	9
4.7 Instructions for use	9
4.8 Environmental conditions.....	9
4.9 Recycling	9
5 Maintenance/repair	10
Annex A (normative) Strength requirements for wagon components and systems for payload protection	11
A.1 General.....	11
A.2 Strength of sliding walls	11
A.3 Forces resulting from the passing of trains	12
A.3.1 Individual strength requirements for sliding walls and their locking devices	12
A.4 Moveable roofs.....	13
A.5 Strength of the side doors of high sided open wagons	13
Annex B (informative) Specification tables	14
B.1 General.....	14
B.2 Application case "Movement of lever parallel to the level of symmetry of the human body, using both hands"	15
B.3 Application case "Pulling and pressing in vertical level, using one hand"	17
B.4 Application case "Pulling and pressing in horizontal level, using one hand"	19
B.5 Application case "Pulling and pressing in horizontal level, using both hands"	21
B.6 Application case "Applied forces for lifting, carrying or holding loads"	23
B.7 Application case "Applied moments at cranks with horizontal rotation axis, parallel to the level of symmetry of the human body, using both hands"	25
Annex ZA (informative) Relationship between this European Standard and the Essential Requirements of EU Directive 2008/57/EC	28
Bibliography	29

Foreword

This document (EN 15723:2010) has been prepared by Technical Committee CEN/TC 256 “Railway applications”, the secretariat of which is held by DIN.

This European Standard shall be given the status of a national standard, either by publication of an identical text or by endorsement, at the latest by July 2010, and conflicting national standards shall be withdrawn at the latest by July 2010.

Attention is drawn to the possibility that some of the elements of this document may be the subject of patent rights. CEN [and/or CENELEC] shall not be held responsible for identifying any or all such patent rights.

This document has been prepared under a mandate given to CEN by the European Commission and the European Free Trade Association, and supports essential requirements of EU Directive(s).

For relationship with EU Directive(s), see informative Annex ZA, which is an integral part of this document.

According to the CEN/CENELEC Internal Regulations, the national standards organizations of the following countries are bound to implement this European Standard: Austria, Belgium, Bulgaria, Croatia, Cyprus, Czech Republic, Denmark, Estonia, Finland, France, Germany, Greece, Hungary, Iceland, Ireland, Italy, Latvia, Lithuania, Luxembourg, Malta, Netherlands, Norway, Poland, Portugal, Romania, Slovakia, Slovenia, Spain, Sweden, Switzerland and the United Kingdom.

Introduction

To achieve an undisturbed, reliable and safe operation of freight trains it is essential to define common requirements for closing and locking devices of protecting devices of interoperable trains with respect to e.g. structural requirements, operating characteristics, way of operation, maintenance as well as their handling.

1 Scope

This European Standard applies to new and upgraded freight wagons where an approval is required. These protecting devices are classified into two types of load and this standard defines the requirements for the durability of the closing and locking devices, their status indication, maintenance and recycling. This standard also defines pass-fail criteria for the dimensioning tests.

NOTE Provisions going beyond the scope of these requirements should be agreed by the contracting parties involved.

This standard is not applicable to closing and locking devices which are used to ensure a pressure difference or to retain liquids /liquid payloads. It is not applicable to vehicles which are emptied by pressure, nor is it applicable to loose tarpaulins.

2 Normative references

The following referenced documents are indispensable for the application of this document. For dated references, only the edition cited applies. For undated references, the latest edition of the referenced document (including any amendments) applies.

EN 349, *Safety of machinery — Minimum gaps to avoid crushing of parts of the human body*

prEN 12663-2, *Railway applications — Structural requirements of railway vehicle bodies — Part 2: Freight wagons*

prEN 15877-1, *Railway applications — Marking on railway vehicles — Part 1: Freight wagons*

3 Terms and definitions

For the purposes of this document, the following terms and definitions apply.

3.1

aerodynamic forces

forces affecting the vehicle and component assemblies by an air stream

3.2

forces from selfmass

inertia forces resulting from dynamic forces applied to the protecting (locking) devices

3.3

unloading door

type of door which is subject to the force of the payload (or a proportion of it)

NOTE The door should be able to be secured against un-planned opening (Category 2).

3.4

movable device to protect

device to protect payload against environmental influences and exterior forces

NOTE 1 Loose tarpaulins are not considered as a movable protecting device.

EXAMPLES Sliding walls, flaps, rigid sliding hoods and covers, hinged doors, bottom doors.

3.5
closing and locking device

device for fixing a movable protecting device in a defined position

3.6
operating module

freight wagon load securing or locking unit activated by operating elements

NOTE An operating module can also be an operating element.

3.7
operating element

element which is operated during loading/unloading

EXAMPLES Removable stanchions, hand wheels, sliding walls, levers or movable tie-downs.

3.8
applied force or moment

body force or moment which acts outwardly from the body

NOTE 1 Applied forces or moments are operating forces.

NOTE 2 In order to activate an operating element, both static and dynamic forces are applied.

3.9
percentile

statement on how many participants of the test group (in percent) are able to summon up the applied force or applied moment

NOTE 1 The applied forces or moments stated in the standards always refer to certain percentiles of the test group.

NOTE 2 Typical values of percentiles are 1, 5, 15, 50 or 95. Here the difference between 100 and the percentile value describes the percentage of the test group, which is able to summon up more than the respective applied force or moment. When stating the 85th percentile this means for instance that 85 % of the test persons are able to carry out the described activity – and 15 % will be able to carry out more than the described activity. When stating the 15th percentile this means for instance that 15 % of the test persons are not able to carry out the described activity – and 85 % will be able to carry out the described activity.

3.10
types of load

classification in two types of loads which are considered for the design of closing and locking devices

NOTE 1 These loads are either internal forces from the load itself or external forces during travelling.

NOTE 2 Examples for when these loads are considered for different door types are shown in Table 1.

3.11
automatic safety device

automatic device that prevents danger from wrong operation to and by the user

3.12
safeguard device

device that safely locks the movable items in their defined (open, close intermediate) position preventing unintentional movements

Table 1 — Types of load

Type of door	Load types		Examples of types
	Category 1 Planned/accepted forces by payload (even unloading by gravity), dynamic forces from payload (including unloading)	Category 2 No forces from payload, dynamic forces from exterior forces only	
Doors, discharge	X	X	Tanoos, Fals HAA, HHA CDA
Sliding walls	X	X	Hbi... wagons VGA
Sliding covers/hoods		X	Shimms Rils
Hinged side doors/ end doors	X	X	E-wagons
Curtain sides		X	
Hoppers with opening roof		X	Tamns
Siding roof "spread eagles"	X	X	

4 Requirements

4.1 General

Doors and hatches of freight vehicles shall be designed to be closed and locked. This remains valid while the vehicles are in a moving train (unless this is part of the procedure for discharging the payload). Wagons fitted with special equipment (automatic discharging, opening roof, etc.) shall have instructions concerning operation of this equipment and the safety precautions to be taken, placed in a prominent position and if possible in several languages; these instructions may be accompanied by appropriate pictograms.

The closing and locking devices shall be designed to withstand the loads which are caused by the payload under normal, regular conditions and when the payload has been displaced in a foreseeable manner (see Table 1, Category 1).

The closing and locking devices shall be designed to withstand the loads which could effect to vehicles during operation.

The side doors and the shutters of the ventilation apertures of covered wagons shall be designed to prevent wear and in service stresses causing deformation and resulting in these elements being ripped or falling off during the shunting process or while the train is moving (particularly during passing of two trains).

For all types of covered wagon with sliding side doors, they shall be equipped with suitably dimensioned devices to prevent any unintended disengagement. The devices shall limit the vertical play and shall take effect in any operating condition.

The forces, which are needed to actuate the closing and locking devices, shall be of a magnitude that can be applied by an operator without additional tools. Exceptions are allowable when additional tools are specifically made available or when motor driven systems are used.

For this, locking devices shall be used which indicate their status (open/closed) and they shall be visible by an operator outside the train.

4.2 Strength of side doors and their locking devices, sliding doors and single and multi-leafed doors under transverse loading

The doors and their locking devices, when closed and locked, shall withstand a horizontal normal force from the inside of the wagon outwards, representing the forces produced by a shift in the load as well as by aerodynamic forces during operation.

No permanent deformation or loss of functionality should occur, either on the door itself (wall and framework) or on the locking, sliding or guiding components as a result of these loads except where other pass-fail-criteria are defined.

The load cases are shown in Annex A.

4.3 Strength of sliding walls and their locking devices

The sliding walls and their locking devices, when closed and locked, should resist a horizontal cross force applied from the inside of the wagon outwards. This force represents the forces produced by a shift of the load as well as by pressure differences resulting from aerodynamic forces during operation.

The load cases and pass-fail criteria are shown in A.2.

4.4 Forces resulting from the passing of trains

4.4.1 General

Locking devices shall maintain their functionality.

The load cases and pass-fail criteria are shown in A.3.

4.4.2 Movable roofs

Movable roofs and their closing and locking devices at least shall meet the requirements as shown in Table 1, Category 2.

The load cases and pass-fail criteria are shown in A.4.

4.4.3 Side doors of high-sided open wagons and their closing and locking devices

The side doors and their closing and locking devices shall maintain their functionality.

The load cases and pass-fail criteria are shown in A.5.

4.4.4 Unloading doors of gravity discharge wagons and their closing and locking devices

Strength of walls

The walls should sustain the maximum permissible loads due to the goods they are intended to carry.

The closing and locking devices shall maintain their functionality when they withstand the maximum permissible load, according to the requirements of 4.2.

According to 4.2.

The manual forces, which are needed to actuate the closing and locking devices, shall be of a magnitude that can be applied by an operator without additional tools. Exceptions are allowable when additional tools are specifically made available or when motor driven systems are used.

The requirements of EN 349 apply.

Guidance concerning the determination of the maximum permissible manual forces is defined in Annex B and Annex C.

4.5 Safeguards of movable protecting devices (i.e. doors, sliding walls, sliding roofs, flaps, hoods)

Movable items shall be provided with automatic safety devices to avoid any wrong movement in the course of opening and closing operations.

Movable items, (i.e. doors, walls, roofs) shall be designed to be secured against unintentional movement when placed in their defined position (open, close intermediate) by safeguard devices which shall work automatically.

The final positions are to be fitted with fixed stops.

Movable items shall be secured positively in their final closing position against unintentional opening by forces from inside the loading space or exterior forces.

Locking devices shall be used whose status (open/closed) is recognisable. Locking devices shall indicate their status in a way that can be checked from outside of the wagon.

The locking devices shall be designed to be secured against unintentional opening during running.

4.6 Verification of durability and functioning

Verification of durability for the locking and closing devices of movable protecting devices of Category 1 (see Table 1) is made according to the respective loads to be determined in as far as the load cases set out in Annex A do not apply.

Verification of durability and functioning for locking and closing devices of movable protecting devices of Category 2 (see Table 1) is made by means of suitable measures. These can be, for example, analogy considerations concerning service-proven design solutions, computational demonstration of durability or tests.

4.7 Instructions for use

Suitable and clear instructions for use shall be applied near each locking device and shall be visible by the operator.

The wagon shall bear inscriptions in one or more languages or pictograms showing the relevant information for safe operation.

Specifications regarding the information and pictograms are defined in prEN 15877-1.

4.8 Environmental conditions

The closing and locking devices shall fulfil as a minimum the environmental conditions applicable to the complete wagon.

4.9 Recycling

The closing and locking devices shall be designed to maximise the use of recyclable materials.

5 Maintenance/repair

Wear, failures and other damage may influence the operational safety of railway vehicles. Depending on the wear behaviour, the utilization parameters and the current condition of the railway vehicles, a maintenance system shall be set up to ensure that the safe functional performance is always achieved. This shall be included in the vehicle maintenance documentation.

The closing and locking systems shall be inspected at defined maintenance periods and remedial action taken if signs of damage or malfunction are found.

Areas subject to wear shall be accessible for inspection and repair.

Documentation shall be provided on the areas to be inspected and the intervals of inspection.

Annex A (normative)

Strength requirements for wagon components and systems for payload protection

A.1 General

Annex A provides the requirements for the design of wagon components and systems for payload protection against environmental influences and exterior forces. The requirements shall be adopted only where they are appropriate to the intended application.

The closing, rolling, guiding and locking devices shall withstand the forces transferred to them during the tests, detailed below.

At the centre of the door a force of 8 kN applies over a 1 m × 1 m area. At each attachment point a force of 5 kN applies over 300 mm × 300 mm area.

No permanent visible deformation or deterioration of the elements for closing, rolling, securing, guiding and locking should result from the application of these test loads.

A.2 Strength of sliding walls

- a) Sliding walls which are less than 2,5 m long should meet the same load cases as sliding doors.
- b) Sliding walls from 2,5 m to 5 m long should have a 20 kN load applied at mid-wall over a 1 m × 1 m area.

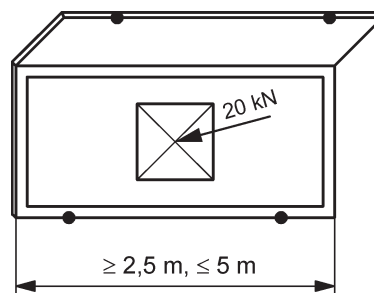

Figure A.1 — Sliding walls from 2,5 m to 5 m long

- c) Sliding walls over 5 m < 7 m long should have a 15 kN load applied in each case at a distance of 1/4 of the sliding wall length from the end of the sliding wall and at a height of 1 m over a 1 m × 1 m area.

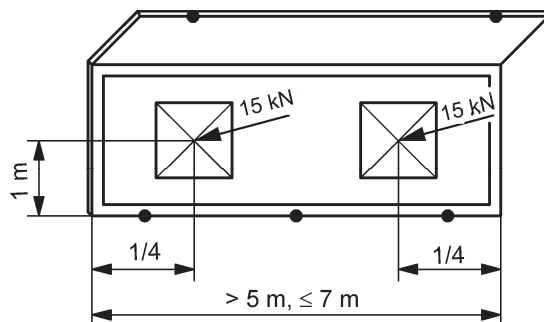

Figure A.2 — Sliding walls over 5 m < 7 m long

- d) Sliding walls over 7 m long should have a 20 kN load applied in each case at a distance of 1/4 of the length of the sliding wall from the end of the sliding wall and at a height of 1 m over a 1 m × 1 m area.

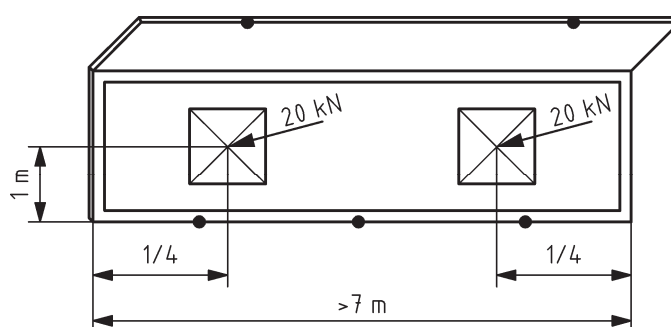

Figure A.3 — Sliding walls over 7 m long

Plus the application of a 10 kN load on the lower flange of a sliding wall between two attachment points immediately above floor level, over an area 200 mm high by 300 mm wide.

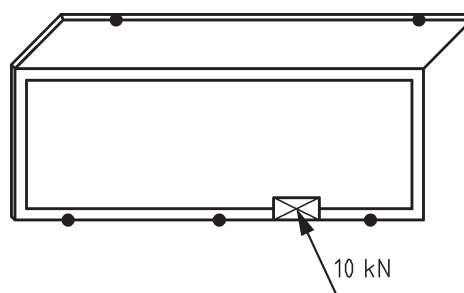

Figure A.4 — Additional test load for sliding walls

No permanent visible deformation or deterioration of the elements for closing, rolling, securing, guiding and locking should result from the application of these test loads.

A.3 Forces resulting from the passing of trains

A.3.1 Individual strength requirements for sliding walls and their locking devices

No permanent visible deformation or deterioration of the elements for closing, rolling and guiding the wall should result from the application of the loads. A permanent deformation, equal at most to half the distance between the inner face of an opened wall and the maximum projecting point of a closed wall, is permissible.

Individual strength requirements for the outside attachment points of the sliding wall (front surface over an area 200 mm high and 300 mm wide):

- a) with two-axle wagons and with bogie wagons with more than two sliding walls per side; force = 11,5 kN;
- b) with bogie wagons with two sliding walls per side; force = 14 kN.

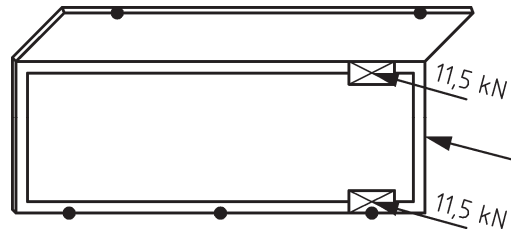

Figure A.5 — Test loads of elements for sliding walls and their locking devices

The point of application should be immediately above the floor and, in the roof area, as close as possible to the upper attachment point. It is permissible for the upper load to be applied to the vertical section of the sliding wall.

No permanent visible deformation or deterioration of the elements for closing, rolling, securing, guiding and locking should result from the application of these test loads.

A.4 Moveable roofs

Sliding roofs shall withstand a vertical force from the inside outwards of 4,5 kN per attachment point applied over a 300 mm × 300 mm square area. No deterioration or permanent deformation of the elements for closing, rolling and guiding the sliding roofs should result from this load.

The test conditions as defined in prEN 12663-2 for moveable roofs shall be applied. Following the test the locking device shall retain its function.

A.5 Strength of the side doors of high sided open wagons

A horizontal force of 20 kN should be applied at a the height of the door locking bar or 1 m above the floor and on the centre-line of the opening.

No permanent visible deformation or deterioration of the elements for closing, rolling, securing, guiding and locking should result from the application of these test loads.

Annex B (informative)

Specification tables

B.1 General

In Annex B the maximum permissible actuating forces at closing and locking devices are defined for various cases of exerting forces.

Annex B contains aids for selecting the cases of exerting forces listed in Table B.1.

Table B.1 — Selection aid for the applied forces shown in Annex B

Table B.2	Movement of lever parallel to the level of symmetry of the human body, using both hands
Table B.3	Pulling and pressing in vertical level, using one hand
Table B.4	Pulling and pressing in horizontal level, using one hand
Table B.5	Pulling and pressing in horizontal level, using both hands
Table B.6	Applied forces for lifting, carrying or holding loads
Table B.7	Applied moments at cranks with horizontal rotation axis, parallel to the level of symmetry of the human body, using one hand

B.2 Application case "Movement of lever parallel to the level of symmetry of the human body, using both hands"

Maximum permissible applied forces at closing and locking devices for the following case of exerting force: Movement of lever parallel to the level of symmetry of the human body, using both hands.¹⁾

Based on a standard person, right-hander, arm length = 700 mm, distance between the two hands < 400 mm.

Since the measurement is taken using a tension spring, there are applied forces listed in the table instead of applied moments.

Application example: Releasing a tarpaulin hood.

Table B.2 — Movement of lever parallel to the level of symmetry of the human body, using both hands

Direction of force	Maximum static applied forces for occasional force application ^{c, d, e}					
	Force application ^{b c} height h_1	Force applied in area A, vertical lever ranging from 45° to 90° or - 45° to - 90°		Force application ^{b c} height h_2	Force applied in area B, vertical lever position ranging from 45° to - 45°	
		Non-safety related	Safety related ^a		Non-safety related	Safety related ^a
Pressure, using both hands	1 850 mm	275 N	220 N	1 850 mm	375 N	290 N
	1 680 mm	315 N	255 N	1 680 mm	375 N	290 N
	1 400 mm	390 N	315 N	1 500 mm	280 N	220 N
	1 200 mm	425 N	300 N	1 320 mm	250 N	195 N
	1 000 mm	410 N	330 N	1 150 mm	190 N	145 N
	800 mm	405 N	280 N	1 000 mm	N.A.	N.A.

1) All applied forces are based upon the details contained in DIN 33411-5:1999, Table 10 and Table 15.

Table B.2 (continued)

Direction of force	Maximum static applied forces for occasional force application ^{c, d, e}					
	Force application ^{b c} height h_1	Force applied in area A, vertical lever ranging from 45° to 90° or - 45° to - 90°		Force application ^{b c} height h_2	Force applied in area B, vertical lever position ranging from 45° to - 45°	
		Non-safety related	Safety related ^a		Non-safety related	Safety related ^a
Tension, using both hands	1 850 mm	230 N	180 N	1 850 mm	315 N	240 N
	1 680 mm	255 N	200 N	1 680 mm	315 N	240 N
	1 400 mm	270 N	210 N	1 500 mm	280 N	220 N
	1 200 mm	285 N	240 N	1 320 mm	315 N	240 N
	1 000 mm	295 N	215 N	1 150 mm	250 N	195 N
	800 mm	320 N	305 N	1 000 mm	N.A.	N.A.

^a Applied forces are safety-relevant whenever the actuating forces are applied in connection with dangerous goods or for closing and locking devices in escape routes (e.g. for safety doors or safety valves).

^b Distance between the footprint area and the hands (see Figures B.1 and B.2).

^c All values exceeding 50 N are rounded to a multiple of 5. Smaller values are rounded to integers.

^d A static work is carried out occasionally in the case of:

- less than 30 repetitions within 1 h;
- less than 60 repetitions within 4 h.

^e Because there is no standard describing a similar case of exerting force, the applied force is approximately given in this table. When using this table please take into consideration that the applied forces are theoretically only valid for the angles 0°, 45° and 180°, because in other cases there are always two components of forces appearing.

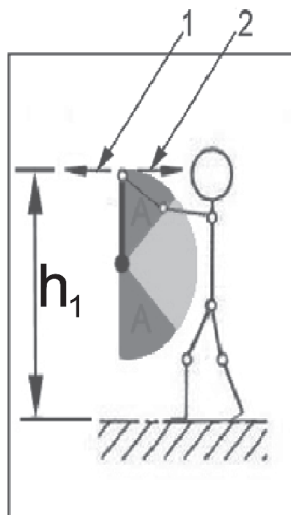

Key

1 pressure

2 tension

h_1 distance between footprint area and the hands

Figure B.1 — Force application case, horizontal tension/pressure

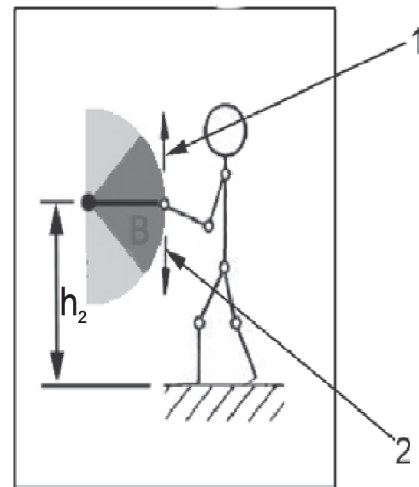

Key

1 tension

2 pressure

h_2 distance between footprint area and the hands

Figure B.2 — Force application case, vertical tension/pressure

B.3 Application case "Pulling and pressing in vertical level, using one hand"

Maximum permissible applied forces at closing and locking devices for the following case of exerting force: Pulling and pressing in vertical level, using one hand.²⁾

Based on a standard person, right-handed, distance between hands < 370 mm.

The applied forces described here refer exclusively to forces applied using the arm but not the body. The forces can be used as a basis for calculating breakaway or closing moments applied to vertical levers at upper body level.

Application example: Laterally unsecuring a movable partition.

2) All applied forces are based upon the details contained in DIN 33411-4:1987, Figure 1.

Table B.3 — Pulling and pressing in vertical level, using one hand

Direction of force	Force application ^{b, e} height	Maximum static applied forces for occasional force application ^{c, d}	
	<i>h</i>	Non-safety related	Safety related ^a
Vertical pressure, using one hand	1 850 mm	120 N	90 N
	1 680 mm	180 N	140 N
	1 500 mm	155 N	120 N
	1 320 mm	95 N	75 N
	1 150 mm	105 N	80 N
	1 000 mm	100 N	80 N
	900 mm	90 N	70 N
Vertical tension, using one hand	1 850 mm	55 N	45 N
	1 680 mm	75 N	60 N
	1 500 mm	95 N	75 N
	1 320 mm	145 N	110 N
	1 150 mm	170 N	130 N
	1 000 mm	140 N	105 N
	900 mm	65 N	50 N

^a Applied forces are safety-relevant whenever the actuating forces are applied in connection with dangerous goods or for opening and locking devices in escape routes (e.g. for safety doors or safety valves).

^b Distance between the footprint area and the hand (see Figure B.1 and Figure B.2).

^c All values exceeding 50 N are rounded to a multiple of 5. Smaller values are rounded to integers.

^d A work is carried out occasionally in the case of:

- less than 30 repetitions within 1 h;
- less than 60 repetitions within 4 h.

^e The height *h* was calculated on the basis of the alpha angle of the standard.

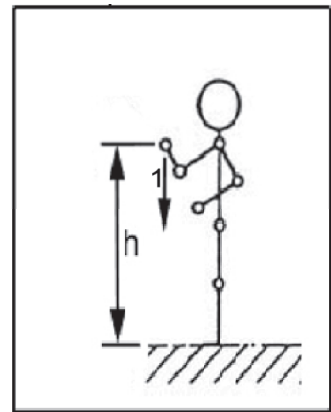

Key

1 pressure

h distance between footprint area and the hands

Figure B.3 — Force application case, vertical pressure, using one hand

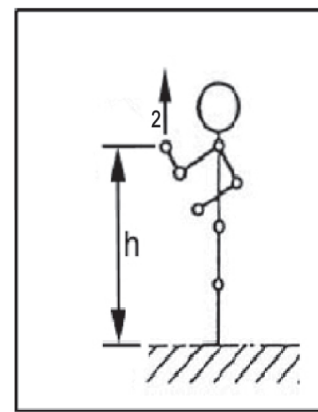

Key

2 tension

h distance between footprint area and the hands

Figure B.4 — Force application case, vertical tension, using one hand

B.4 Application case "Pulling and pressing in horizontal level, using one hand"

Maximum permissible applied forces at closing and locking devices for the following case of exerting force: Pulling and pressing in horizontal level, using one hand.³⁾

Based on a standard person, distance between the two hands < 380 mm.

The applied forces mentioned here exclusively apply to exerting force by the arm without using the body.

Example of use: Pulling out an overtravel plate at car-carrier wagons.

The applied forces can be used as a basis for calculating break-away and closing moments at horizontal levers in the height of the upper body.

Table B.4 — Pulling and pressing in horizontal level, using one hand

Direction of force	Force application height ^{b, e}	Maximum static applied forces for occasional force application ^{c, d, e}	
		Non-safety related	Safety related ^a
Pushing horizontally, using one hand	1 850 mm	95 N	75 N
	1 680 mm	105 N	80 N
	1 500 mm	115 N	85 N
	1 320 mm	100 N	80 N
	1 150 mm	90 N	70 N
	1 000 mm	95 N	75 N
	900 mm	100 N	80 N

3) All applied forces are based upon the details contained in DIN 33411-4:1987, Figure 3.

Table B.4 (continued)

Direction of force	Force application height ^{b, e}	Maximum static applied forces for occasional force application ^{c, d}	
		Non-safety related	Safety related ^a
Pulling horizontally, using one hand	1 850 mm	75 N	60 N
	1 680 mm	75 N	60 N
	1 500 mm	80 N	65 N
	1 320 mm	85 N	65 N
	1 150 mm	90 N	70 N
	1 000 mm	95 N	75 N
	900 mm	95 N	75 N

^a Applied forces are safety-relevant whenever the actuating forces are applied in connection with dangerous goods or for closing and locking devices in escape routes (e.g. for safety doors or safety valves).

^b Distance between the footprint area and the hand (see Figure B.5 and Figure B.6).

^c All values exceeding 50 N are rounded to a multiple of 5. Smaller values are rounded to integers.

^d A work is carried out occasionally in the case of:

- less than 30 repetitions within 1 h;
- less than 60 repetitions within 4 h.

^e The height h was calculated by means of trigonometric functions on the basis of the alpha angle of the standard.

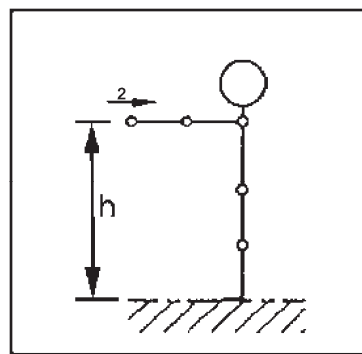
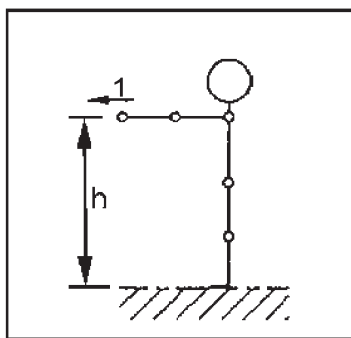

Key

1 pressure

h distance between footprint area and the hands

Key

2 tension

h distance between footprint area and the hands

Figure B.5 — Force application case, horizontal pressure, using one hand

Figure B.6 — Force application case, horizontal tension, using one hand

B.5 Application case "Pulling and pressing in horizontal level, using both hands"

Maximum permissible applied forces at closing and locking devices for the following case of exerting force: Pulling and pressing in horizontal level, using both hands.⁴⁾

Based on a standard person, standing with one foot forward, distance between hands < 440 mm.

Application example: Moving a stanchion on a wire coil car type Rs-y 667.

Table B.5 — Pulling and pressing in horizontal level, using both hands

Direction of force	Force application height h^b	Maximum static applied forces for periodic force application ^{c, d}	
		Non-safety related	Safety related ^a
Pushing horizontally, using one hand	1 850 mm ^e	205 N	165 N
	1 680 mm ^e	235 N	190 N
	1 400 mm	295 N	240 N
	1 200 mm	320 N	225 N
	1 000 mm	310 N	245 N
	800 mm	305 N	210 N
Pulling horizontally, using both hands	1 850 mm ^e	170 N	135 N
	1 680 mm ^e	195 N	150 N
	1 400 mm	205 N	150 N
	1 200 mm	215 N	180 N
	1 000 mm	220 N	160 N
	800 mm	240 N	230 N
^a	Applied forces are safety-relevant whenever the actuating forces are applied in connection with dangerous goods or for closing and locking devices in escape routes (e.g. for safety doors or safety valves).		
^b	Distance between the footprint area and the hand (see Figure B.7 and Figure B.8).		
^c	All values exceeding 50 N are rounded to a multiple of 5. Smaller values are rounded to integers.		
^d	A work is carried out occasionally in the case of:		
	— less than 30 repetitions within 1 h;		
	— less than 60 repetitions within 4 h.		
^e	The height h was calculated by means of trigonometric functions on the basis of the alpha angle of the standard.		

4) All applied forces are based upon the details contained in DIN 33411-4:1987, Figure 3.

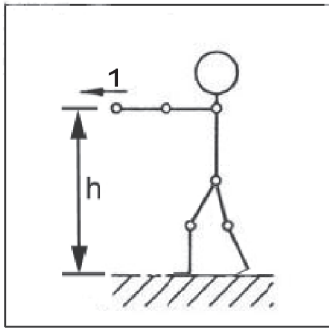

Key

- 1 pressure
- h distance between footprint area and the hands

Figure B.7 — Force application case, horizontal pressure, using both hands

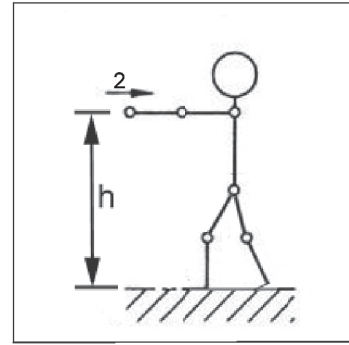

Key



- 2 tension
- h distance between footprint area and the hands

Figure B.8 — Force application case, horizontal tension, using both hands

B.6 Application case "Applied forces for lifting, carrying or holding loads"

Maximum permissible applied forces for lifting, carrying or holding loads.⁵⁾

Table B.6 — Applied forces for lifting, carrying or holding loads

Diagram No.	Typical body and load position ^d	Body position, load position	Maximum force for dynamic muscle stress ^a		Maximum force for static muscle stress ^b	
			Frequency <i>n</i> of the action per shift		Total stress input time per shift ^c	
			<i>n</i> < 40	40 ≤ <i>n</i> < 200	< 15 min	< 60 min
1		Upper torso erect and not twisted Load close to body	< 400 N	< 200 N	< 400 N	< 200 N
2		Slight forward bending or twisting of the torso Load at or close to the body	< 400 N	< 200 N	< 400 N	< 200 N
3		Deep bending or bending far forward Slight forward bending while simultaneously twisting the upper body Load away from the torso or above shoulder height	< 300 N	< 100 N	< 300 N	< 100 N

⁵⁾ All applied forces are based on BGI 523.

Table B.6 (continued)

Diagram No.	Typical body and load position ^d	Body position, load position	Maximum force for dynamic muscle stress ^a		Maximum force for static muscle stress ^b	
			Frequency <i>n</i> of the action per shift		Total stress input time per shift ^c	
			<i>n</i> < 40	40 ≤ <i>n</i> < 200	< 15 min	< 60 min
4		Reaching far forward while simultaneously twisting the upper body Load held away from the body Limited holding stability when standing, crouching or kneeling	< 200 N	-	< 200 N	-

- ^a The forces apply to dynamic actions, e.g. for lifting and moving sequences.
- ^b The forces apply for static actions with the stress input time starting at approx. 5 s.
- ^c Frequency *n* using the following formula: *Frequency* = (total loading time per shift / stress input time).
- ^d Figure 2 to Figure 4 show mainly the positions that occur during a dynamic movement sequence.
- The table can be used, for example, for the following force application cases:
- defining the applied force to raise sideboards (use only half the weight of the sideboard);
 - defining the applied force to move bolsters.

B.7 Application case "Applied moments at cranks with horizontal rotation axis, parallel to the level of symmetry of the human body, using both hands"

Maximum permissible operating moment for hand wheels without crank.⁶⁾

Application example: Opening gates on bulk goods cars.

Table B.7 — Applied moments at cranks with horizontal rotation axis, parallel to the level of symmetry of the human body, using both hands

	Force application height h^c	Static friction breakout/closing moment for occasional moment application ^{b, c, f}			
		Hand wheel diameter = 250 mm		Hand wheel diameter = 400 mm	
		Non-safety related	Safety related ^a	Non-safety related	Safety related ^a
Hand wheel horizontal, in front of the body, standing, using both hands, see Figure B.9	500 mm ^f	65 Nm	55 Nm	115 Nm	105 Nm
	800 mm ^f	70 Nm	60 Nm	125 Nm	115 Nm
	1 000 mm	70 Nm	60 Nm	125 Nm	115 Nm
	1 200 mm	70 Nm	60 Nm	125 Nm	115 Nm
	1 400 mm	65 Nm	55 Nm	105 Nm	95 Nm
	1 600 mm	50 Nm	43 Nm	85 Nm	75 Nm
	1 800 mm	45 Nm	38 Nm	65 Nm	55 Nm

6) All calculations are based on DIN 33411-3.

Table B.7 (continued)

	Force application height h^d	Static friction breakout/closing moment for occasional moment application ^{b, c, f}			
		Hand wheel diameter = 250 mm		Hand wheel diameter = 400 mm	
		Non-safety related	Safety related ^a	Non-safety related	Safety related ^a
Hand wheel vertical in front of the body, standing, using both hands, see Figure B.10	600 mm ^f	65 Nm	55 Nm	115 Nm	100 Nm
	800 mm ^f	55 Nm	47 Nm	95 Nm	85 Nm
	1 000 mm	55 Nm	43 Nm	80 Nm	70 Nm
	1 200 mm	50 Nm	43 Nm	75 Nm	65 Nm
	1 400 mm	50 Nm	43 Nm	75 Nm	65 Nm
	1 600 mm	50 Nm	43 Nm	80 Nm	70 Nm
	1 800 mm	55 Nm	50 Nm	85 Nm	75 Nm

^a An applied moment is defined as safety related if the moment shall be applied in the presence of dangerous goods or to open or close devices located along escape routes (e.g., safety doors or safety valves).

^b For hand wheels with a rim diameter other than 400 mm, the moments shall be recalculated. For two-handed activation:
 Moment = Force × d/2.

^c The values are the same regardless of the direction of the applied moments.

^d Distance between the footprint and middle of the hand wheel rim diameter (horizontal), see Figure B.9, or to the hand wheel axle (vertical), see Figure B.10.

^e All moments greater than 50 Nm are rounded to the nearest multiple of 5.

^f Moment is defined as being applied occasionally when:

- it is repeated less than 30 times inside of 1 h;
- it is repeated less than 60 times inside of 4 h.

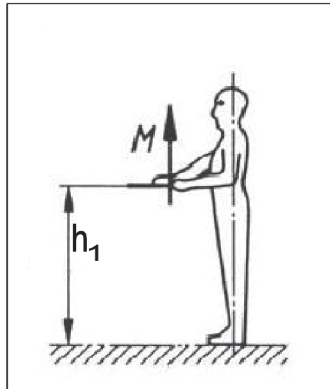

Key

h_1 distance between footprint area and middle of hand wheel rim diameter

M application moment

Figure B.9 — Moment application case, hand wheel horizontal

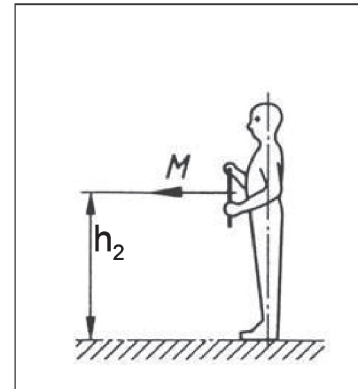

Key

h_2 distance between footprint area and wheel turning axle

M application moment

Figure B.10 — Moment application case, hand wheel vertical

Annex ZA (informative)

Relationship between this European Standard and the Essential Requirements of EU Directive 2008/57/EC

This European Standard has been prepared under a mandate given to CEN/CENELEC/ETSI by the European Commission and the European Free Trade Association to provide a means of conforming to Essential Requirements of the New Approach Directive

— 2008/57/EC of the European Parliament and of the Council of 17 June 2008 on the interoperability of the rail system within the Community.⁷⁾

Once this standard is cited in the Official Journal of the European Union under that Directive and has been implemented as a national standard in at least one Member State, compliance with the clauses of this standard given in Table ZA.1 confers, within the limits of the scope of this standard, a presumption of conformity with the corresponding Essential Requirements of that Directive and associated EFTA regulations.

Table ZA.1 — Correspondence between this European Standard and Directive 2008/57/EC

Clauses/§/annexes of this European Standard	Chapter/§/points and annexes of the CR TSI Rolling Stock WAG dated July 2006 and published in the Official Journal on 8 December 2006	Corresponding text, articles/§/annexes of the Directive 2008/57/EC	Comments
Clauses 1, 2, 3, 4 Annexe A Annexe B	4.2.2.4 Doors closing and locking Annex YY Structures and mechanical parts Strength requirements for certain types of wagon components	Annexe III, Essential Requirements, General Requirements – Clauses 1.1.1, 1.1.3, 1.1.5 Safety Annex III, Essential Requirements, General Requirements – Clause 1.2 Reliability and availability Annex III, Essential Requirements, Requirements Specific to Rolling Stock Subsystem – Clause 2.4.3 Technical compatibility 3 rd §	

WARNING — Other requirements and other EU Directives may be applicable to the product(s) falling within the scope of this standard.

7) Official Journal of the European Union No L191/1 of 18.07.2008.

Bibliography

- [1] DIN 950, *Handräder gekröpft — Nabenloch rund oder mit geradem Vierkant*
- [2] DIN 33411 (all parts), *Körperkräfte des Menschen*
- [3] EN 14067 (all parts), *Railway applications — Aerodynamics*
- [4] EN 1005-1, *Safety of machinery — Human physical performance — Part 1: Terms and definitions*
- [5] DIN 33402 (all parts), *Ergonomie — Körpermaße des Menschen*
- [6] EN 894 (all parts), *Safety of machinery — Ergonomics requirements for the design of displays and control actuators*
- [7] EN 12453, *Industrial, commercial and garage doors and gates — Safety in use of power operated doors — Requirements*
- [8] BGI 523, *Mensch und Arbeitsplatz*⁸⁾ BWA, Wegleitung zur Verordnung 3 des Arbeitsgesetz, 1 Überarbeitung, März 1998, Art 23, 323-2, Abbildung 323-1, 323-2.
- [9] Schmidtke, Heinz (Hrsg.), *Ergonomie*, Auflage 3, München, Wien 1993, Seite 128, Seite 134, Seite 135, Seite 489, Seite 490.
- [10] www.meduniqua.at/module/gesundLeben/physiorueckenguede/01/1_7_1.htm
- [11] http://www.baua.de/nn_5846/de/Themen-von-A-Z/Physische-Belastung/pdf/LMM-Ziehen-Schieben.pdf
- [12] http://www.baua.de/nn_5846/de/Themen-von-A-Z/Physische-Belastung/pdf/LMM-Heben-Halten-Tragen-2.pdf
- [13] http://www.baua.de/nn_5846/de/Themen-von-A-Z/Physische-Belastung/pdf/LMM-Ziehen-Schieben-2.pdf
- [14] http://www.baua.de/nn_5846/de/Themen-von-A-Z/Physische-Belastung/pdf/LMM-Heben-Halten-Tragen.pdf

8) Available at the Federal Institution for Industrial Safety and Industrial Medicine (<http://www.baua.de/>).

BSI - British Standards Institution

BSI is the independent national body responsible for preparing British Standards. It presents the UK view on standards in Europe and at the international level. It is incorporated by Royal Charter.

Revisions

British Standards are updated by amendment or revision. Users of British Standards should make sure that they possess the latest amendments or editions.

It is the constant aim of BSI to improve the quality of our products and services. We would be grateful if anyone finding an inaccuracy or ambiguity while using this British Standard would inform the Secretary of the technical committee responsible, the identity of which can be found on the inside front cover. Tel: +44 (0)20 8996 9000. Fax: +44 (0)20 8996 7400.

BSI offers members an individual updating service called PLUS which ensures that subscribers automatically receive the latest editions of standards.

Buying standards

Orders for all BSI, international and foreign standards publications should be addressed to Customer Services. Tel: +44 (0)20 8996 9001. Fax: +44 (0)20 8996 7001 Email: orders@bsigroup.com You may also buy directly using a debit/credit card from the BSI Shop on the Website <http://www.bsigroup.com/shop>

In response to orders for international standards, it is BSI policy to supply the BSI implementation of those that have been published as British Standards, unless otherwise requested.

Information on standards

BSI provides a wide range of information on national, European and international standards through its Library and its Technical Help to Exporters Service. Various BSI electronic information services are also available which give details on all its products and services. Contact Information Centre. Tel: +44 (0)20 8996 7111 Fax: +44 (0)20 8996 7048 Email: info@bsigroup.com

Subscribing members of BSI are kept up to date with standards developments and receive substantial discounts on the purchase price of standards. For details of these and other benefits contact Membership Administration. Tel: +44 (0)20 8996 7002 Fax: +44 (0)20 8996 7001 Email: membership@bsigroup.com

Information regarding online access to British Standards via British Standards Online can be found at <http://www.bsigroup.com/BSOL>

Further information about BSI is available on the BSI website at <http://www.bsigroup.com>.

Copyright

Copyright subsists in all BSI publications. BSI also holds the copyright, in the UK, of the publications of the international standardization bodies. Except as permitted under the Copyright, Designs and Patents Act 1988 no extract may be reproduced, stored in a retrieval system or transmitted in any form or by any means – electronic, photocopying, recording or otherwise – without prior written permission from BSI.

This does not preclude the free use, in the course of implementing the standard, of necessary details such as symbols, and size, type or grade designations. If these details are to be used for any other purpose than implementation then the prior written permission of BSI must be obtained.

Details and advice can be obtained from the Copyright and Licensing Manager. Tel: +44 (0)20 8996 7070 Email: copyright@bsigroup.com

BSI Group
Headquarters 389
Chiswick High Road,
London, W4 4AL, UK
Tel +44 (0)20 8996 9001
Fax +44 (0)20 8996 7001
[www.bsigroup.com/
standards](http://www.bsigroup.com/standards)