

Steel static storage systems — Application and maintenance of storage equipment

ICS 53.080

National foreword

This British Standard is the UK implementation of EN 15635:2008.

The UK participation in its preparation was entrusted to Technical Committee MHE/8, Steel shelving, bins and lockers.

A list of organizations represented on this committee can be obtained on request to its secretary.

This publication does not purport to include all the necessary provisions of a contract. Users are responsible for its correct application.

Compliance with a British Standard cannot confer immunity from legal obligations.

This British Standard was published under the authority of the Standards Policy and Strategy Committee on 31 January 2009

© BSI 2009

ISBN 978 0 580 55991 4

Amendments/corrigenda issued since publication

Date	Comments

EUROPEAN STANDARD

EN 15635

NORME EUROPÉENNE

EUROPÄISCHE NORM

November 2008

ICS 53.080

English Version

Steel static storage systems - Application and maintenance of storage equipment

Systèmes de stockage statiques en acier - Utilisation et maintenance de système de stockage

Ortsfeste Regalsysteme aus Stahl - Anwendung und Wartung von Lagereinrichtungen

This European Standard was approved by CEN on 5 October 2008.

CEN members are bound to comply with the CEN/CENELEC Internal Regulations which stipulate the conditions for giving this European Standard the status of a national standard without any alteration. Up-to-date lists and bibliographical references concerning such national standards may be obtained on application to the CEN Management Centre or to any CEN member.

This European Standard exists in three official versions (English, French, German). A version in any other language made by translation under the responsibility of a CEN member into its own language and notified to the CEN Management Centre has the same status as the official versions.

CEN members are the national standards bodies of Austria, Belgium, Bulgaria, Cyprus, Czech Republic, Denmark, Estonia, Finland, France, Germany, Greece, Hungary, Iceland, Ireland, Italy, Latvia, Lithuania, Luxembourg, Malta, Netherlands, Norway, Poland, Portugal, Romania, Slovakia, Slovenia, Spain, Sweden, Switzerland and United Kingdom.



EUROPEAN COMMITTEE FOR STANDARDIZATION
COMITÉ EUROPÉEN DE NORMALISATION
EUROPÄISCHES KOMITEE FÜR NORMUNG

Management Centre: rue de Stassart, 36 B-1050 Brussels

Contents

Page

Foreword.....	4
0 Introduction	5
1 Scope	6
2 Normative references	6
3 Terms and definitions	6
4 Operational requirements	9
4.1 System requirements	9
4.2 Storage systems planning	9
5 Important data of relevance to the user	9
6 Assembly and installation	10
6.1 Skills required and provision of instructions	10
6.2 Installation quality and structural design	10
6.3 Aspects of installation work to be observed	11
7 Changes to the storage equipment configuration	12
8 Use of the storage equipment	13
8.1 General safety	13
8.1.1 Person responsible for storage equipment safety PRSES	13
8.1.2 Safe load warning notices	13
8.1.3 Training.....	13
8.1.4 Access to storage levels.....	13
8.2 Pallet or load carrying accessories	13
8.2.1 Loading.....	13
8.2.2 Pallet requirements.....	14
8.2.3 Special load make up accessories and loads.....	14
8.2.4 Precautions necessary for the use of weak pallets and pallets spanning in the incorrect direction.....	15
8.3 Unit load.....	15
8.3.1 Weight.....	15
8.3.2 Load stability.....	15
8.3.3 Unit load clearances.....	15
8.4 Unit load handling.....	16
8.4.1 Placement of loads	16
8.4.2 Damage to storage equipment	16
8.4.3 Timber pallet usage	16
8.4.4 Load make up accessory positioning on supports.....	16
8.4.5 Pallet positioning on the floor	17
8.4.6 Aisle obstructions.....	17
8.4.7 Handling on raised storage areas or on storage equipment supported floors.....	17
8.4.8 Operating aisle clearances	18
8.5 Placement on adjustable pallet racking	19
8.6 Placement in drive-in racking.....	20
8.6.1 Placement.....	20
8.6.2 Loading and unloading sequence for drive-in-racking.....	21
8.6.3 Use of drive-through racking access routes by trucks	22
8.7 Truck mast stiffness and floor flatness.....	22
9 Safety of storage equipment in use and evaluation of damaged components.....	23
9.1 Procedures	23

9.2	User's responsibilities	23
9.3	Reduction of safety level (margin of safety) due to damage	24
9.4	Inspection of storage equipment.....	24
9.4.1	General	24
9.4.2	Inspection.....	25
9.4.3	Inspection of automated systems	25
9.4.4	Damage investigation	26
9.4.5	Damage control procedures.....	26
9.4.6	Inspection for overload damage to beams, cantilevers or shelves	26
9.4.7	Inspection of beam connector locks	27
9.4.8	Inspection of frame uprights for out of verticality	27
9.4.9	Inspection of guidance systems for VNA trucks.....	28
9.5	Rules for the measurement and classification of damage to uprights and bracings	28
9.5.1	Measuring method for upright damage and residual deformation limits, typical for APR systems	28
9.5.2	GREEN LEVEL - requiring surveillance only	29
9.5.3	AMBER RISK – hazardous damage requiring action as soon as possible	29
9.5.4	RED RISK – very serious damage requiring immediate action	30
9.6	Rules for the evaluation of damage to pallet rack beams.....	30
9.7	Damage action procedures	30
9.7.1	Replacement of damaged components	30
9.7.2	Typical damage patterns	30
9.7.3	Inspection procedure flowchart, Inspection – Evaluation – Action	30
10	Changes that require a safety review of storage operations.....	31
Annex A (informative) Supplier's responsibilities		33
Annex B (informative) Examples of typical load warning notices		34
B.1	Load warning notices.....	34
B.2	Load warning notice layout.....	34
B.3	Training.....	34
B.4	Display.....	34
B.5	Checking load warning notice information.....	34
B.6	Equipment inspections	34
B.7	Sizes.....	34
Annex C (informative) Pallet damage.....		49
Annex D (informative) Safety of storage equipment in use and evaluation of damaged components		51
D.1	Reduction in margin of safety of damaged racking uprights or bracing members	51
D.2	Storage equipment inspections.....	53
D.2.1	General	53
D.2.2	Inspection schedules	54
D.2.3	Inspection for overloading of beams, cantilevers or shelves.....	54
Annex E (informative) Use of the storage equipment – Method of placement and orientation.....		56
E.1	General	56
E.2	Placement and asymmetric loading	56
E.3	Unevenly distributed loading on pallets or other media	58
E.4	Incorrect placement of unit loads.....	59
E.5	Correct and incorrect location of unit loads.....	59
Bibliography.....		61

Foreword

This document (EN 15635:2008) has been prepared by Technical Committee CEN/TC 344 "Steel static storage systems", the secretariat of which is held by UNI.

This European Standard shall be given the status of a national standard, either by publication of an identical text or by endorsement, at the latest by May 2009, and conflicting national standards shall be withdrawn at the latest by May 2009.

Attention is drawn to the possibility that some of the elements of this document may be the subject of patent rights. CEN [and/or CENELEC] shall not be held responsible for identifying any or all such patent rights.

According to the CEN/CENELEC Internal Regulations, the national standards organizations of the following countries are bound to implement this European Standard: Austria, Belgium, Bulgaria, Cyprus, Czech Republic, Denmark, Estonia, Finland, France, Germany, Greece, Hungary, Iceland, Ireland, Italy, Latvia, Lithuania, Luxembourg, Malta, Netherlands, Norway, Poland, Portugal, Romania, Slovakia, Slovenia, Spain, Sweden, Switzerland and the United Kingdom.

0 Introduction

0.1 Structural Eurocodes for load-bearing structures and buildings

The Commission of the European Communities (CEC) initiated the work of establishing a set of harmonized technical rules for the design of building and civil engineering works, which would initially serve as an alternative to the different rules in force in the various member states and would ultimately replace them. These technical rules are known as the "Structural Eurocodes".

Because the determination of the safe load-bearing capacity of static storage systems is a structural engineering task, the Eurocodes are relevant, particularly EN 1993-1-1 and EN 1993-1-3, as far as the design is concerned. The codes and guidelines produced by CEN/TC 344 are intended to amplify and clarify the requirements of the Eurocodes since they particularly apply to design while specification, installation and application and maintenance are considered as special requirements for racking and shelving products. This European Standard considers application and maintenance.

0.2 Additional European Standards for racking and shelving

Due to the differences in the shape of structural components, detailing and connection types, additional technical information to the Eurocodes is required in order to provide state of the art guidance. This guidance is for the client or consultant specifying the requirement, the designer producing a sound structural design, the installer building the structure and the user who operates and maintains the structure in accordance with the design specification.

This together with the need to provide harmonized design rules, is the reason that the European Racking Federation (ERF) has taken the initiative to support this development of a range of European Standards for specific types of racking and shelving used in specific applications (see bibliography).

0.3 Additional information specific to EN 15635

This European Standard gives additional information to that in Eurocodes EN 1990 and EN 1991, to be used in the structural design of storage systems (see also prEN 15512) and is intended for use by:

- a) committees drafting design related product, testing and execution standards;
- b) clients (e.g. for the formulation of their specific requirements);
- c) specifiers, designers, suppliers, installers and end users of the product;
- d) relevant building control authorities.

Expertise in the technical properties of racking components and knowledge of the specific methods of calculation to determine the safe load carrying capacity data for the products shall be available normally from the manufacturer of that product. These standardized products can have infinite variation in their configuration. Structural engineering in steel requires special attention for the cold formed sections normally in use and for flexural and (overall) frame instability. Users should refer to prEN 15512 for more information on these aspects.

Users of storage equipment should refer to EN 15629 to ensure that the specified layout and configuration is not in conflict with the methods of operation, ensuring safe operating conditions in the workplace.

This European Standard deals with these user-defined aspects. A clear user specification for the provision of a safe storage equipment design is an essential basis to provide and complement safe working conditions.

This European Standard is also relevant to specifiers and suppliers.

1 Scope

This European Standard gives guidelines for operational aspects relevant to structural safety of storage systems. Such systems operate with heavy mechanical handling equipment working in close proximity to static storage equipment. This European Standard minimizes the risk and consequences of unsafe operation or damage to the structure. Some other forms of storage equipment are only partially covered and further consideration, beyond the scope of this European Standard, can be required.

This European Standard gives guidance in conjunction with prEN 15512, EN 15620, and EN 15629 to ensure that the specifier, user and designer are aware of the constraints in each other's area to allow a safe design to be produced.

This European Standard specifically excludes storage equipment manufactured from materials other than steel (except for certain accessories) and equipment intended to be used for domestic storage purposes

2 Normative references

The following referenced documents are indispensable for the application of this document. For dated references, only the edition cited applies. For undated references, the latest edition of the referenced document (including any amendments) applies.

EN 15629, *Steel static storage systems — The specification of storage equipment*

EN 15620, *Steel static storage systems — Adjustable pallet racking — Tolerances, deformations and clearances*

3 Terms and definitions

For the purposes of this document, the following terms and definitions apply.

3.1 adjustable pallet racking APR

steelwork structure consisting of frames and beams adjustable in height, specifically designed to support load make up accessories and unit loads

3.2 allowable loading

beam, frame or shelf safe load capacity indicated by the storage equipment supplier to the user on the safe load warning notices based upon the data supplied by the specifier

3.3 bay load

total allowable weight of all the unit loads in a bay of racking not including any unit loads that can be stored on the floor of the bay

3.4 clearance

nominal dimension between items

3.5 compartment load

load, which can be loaded into one compartment of a rack or shelving structure from one side

3.6

competent person

person who by means of a combination of training, experience and education has the knowledge to carry out the task and safety requirements effectively

3.7

crane racking

pallet racking arranged as a very narrow aisle system and operated by a stacker crane running on a rail and laterally supported by the racking structure

3.8

frame load

total allowable weight of all the loads transmitted to the frame by the members attached to the frame

3.9

foundation

floor construction on which the equipment is erected and to which it is fixed to provide anchorage and stability

3.10

installer

trained and qualified as a competent person who assembles and builds the racking at the site location

NOTE The installer should be trained and experienced in the work to be done and should be properly supervised and controlled to ensure that the health and safety of workers and others is safeguarded.

3.11

intrusive stacking

placement or retrieval of a pallet where the turning radius or length of fixed-fork lift truck is greater than the aisle width and part of the storage location concerned is used by the truck forks and load when turning to place or retrieve a pallet

3.12

load make up accessory

LMA

storage unit for the handling of loads by lift trucks

NOTE Examples of load make up accessories include pallets, containers, bins, boxes, barrels and stillages

3.13

mechanical handling equipment

MHE

equipment used to transport the unit load to be stored

3.14

pallet

portable platform, with or without superstructure, for the assembly of a quantity of goods to form a unit load for handling and storage by mechanical appliances

3.15

pallet buffer back stop

buffering back stop which is specified as an aid for use by forklift truck drivers to deposit a unit load in the correct position in the racking

3.16

pallet safety back stop

safety back stop to prevent accidental collision of a pallet or its load with other unit loads or equipment, when that load is placed in the storage compartment

type (a) safety device, which protects against unintentional load movement within the racking and prevents loads from protruding or from falling into an aisle or into an area accessible to people

type (b) backstop to prevent accidental damage, usually placed at the back of a storage compartment, to prevent the accidental collision of a pallet or its load with other equipment, such as sprinklers, when a load is placed in the storage compartment

3.17

pick up and deposit stations

P and D stations

storage locations at the end of an aisle used as an interface between different types of mechanical handling equipment

NOTE The P and D stations can be used as an interface between the unit load and handling equipment that is dedicated to the rack aisle (such as very narrow aisle (VNA) trucks or cranes) and the conveyors or free movement trucks which service the installation. The P and D stations can also be used to accurately fix the location of the unit load relative to the racking. This is often used by trucks or cranes having a fixed length of fork stroke and ensures accuracy in the X and Z directions when placing the unit load onto the racking beams.

3.18

person responsible for storage equipment safety

PRSES

person appointed by the warehouse management with responsibility for maintaining the safe operation of the warehouse storage system

3.19

specification

detailed description of the user's requirements including the racking specification and other data such as the ambient storage conditions, the floor construction, local authority requirements, etc. including all details affecting either the design of the installation or its construction

3.20

specified allowable load

unit load allowed in the storage equipment

3.21

specifier

person or company that provides the supplier with a specification based on the user's requirements

NOTE The specifier can be a consultant or other specialist, the end user or the equipment supplier acting as the specifier.

3.22

supplier

company that supplies the storage equipment

NOTE The company can be the original manufacturer or an intermediate company acting as a distributor.

3.23

total racking or shelving load

total allowable load supported by all the primary load supporting members

NOTE This may be the total load from beams or shelves in a defined area of racking or shelving.

3.24

truck operator

person trained and responsible for the safe use of an individual fork lift truck or a range of such equipment

NOTE This would normally be rider-controlled equipment but could also include pedestrian-controlled powered equipment together with hand-operated pallet trucks.

3.25

unit load

weight of an individual stored item that can be placed or retrieved in one operation

3.26

user

company or person who manages and operates the installation on a daily basis and is responsible for the continuing safety of the installation

3.27

90° stacking

placement or retrieval of a pallet where the forklift truck makes a 90° turn to face the rack during the placement or retrieval process

NOTE In making this turn no part of the truck or load intrudes into the racking.

4 Operational requirements

4.1 System requirements

Before first use and continuously during the operation the user shall verify that the data in the project specification is still valid.

4.2 Storage systems planning

In order to determine a safe design of the storage equipment to be supplied for the load carrying capacity the following information shall be provided by the user to the specifier (see EN 15629):

- a) details of the building in which the storage system is intended to be housed and its environment;
- b) properties of the floor used as the foundation for the storage and mechanical handling equipment;
- c) details of the goods to be stored on the equipment and specification of any pallet or other type of load-carrying accessory;
- d) specification of the allowable loads for the storage equipment;
- e) layout and configuration of the equipment to allow for sufficient design clearances to be provided for the safe depositing and retrieval of goods considering the given throughput;
- f) specification of the handling equipment to be used, e.g. type of truck, etc. in relation to the storage equipment. (See EN 15620 for information on a truck's turning radius and operating aisle width requirements);
- g) specified requirements for collision protection and resistance to impact;
- h) specify who shall carry out the installation of the storage equipment (see 6.1);
- i) known information about planned future changes to storage requirements.

5 Important data of relevance to the user

In order to ensure safe use of storage equipment:

- a) storage equipment shall be built in accordance with the specification, plans and the detailed instructions for assembly provided by the supplier. Where the user constructs the installation, it shall comply with the installation instructions of the supplier (see 6.1);
- b) building floor shall have a degree of strength, stiffness, surface levelness and flatness suitable for operational purposes;
- c) in order to instruct the user of the system, a printed load warning notice shall be provided by the supplier giving sufficient loading information on the equipment and shall be permanently displayed by the user on, or adjacent to, the racking or shelving;

NOTE For information to be supplied to the user see Annex A

- d) user management procedure shall ensure that the maximum load conditions stated on the notice are not exceeded (see Annex B for typical warning and load warning notice types.) The procedure shall also ensure that the quality and type of LMA to be used is suitable for the storage equipment;
- e) method of operation shall be in accordance with the supplier's instructions;
- f) lift truck chosen shall be compatible with the racking structure and floor and shall be suitable for the safe loading and unloading of the racks;
- g) turning circle of the lift truck combined with the overall dimensions of the unit loads shall be compatible with the rack aisle width provided (see 8.4.8 and EN 15620);
- h) user shall be responsible for ensuring that during normal working operations the MHE to be used shall be operated in accordance with the instructions of the supplier of that equipment such that it does not damage the storage equipment. Unless the specification includes a requirement for collision protection or a requirement for impact resistance, the storage equipment will be designed for no special effects other than the normal loads and forces arising from good practice in the careful use of the storage-handling equipment by well-trained operatives.

6 Assembly and installation

6.1 Skills required and provision of instructions

The correct assembly and installation of the storage equipment shall be carried out in accordance with the instructions provided by the supplier in a professional manner and is of equal importance to the provision of a safe structural design. The quality and accuracy of the works can have a profound influence on the performance of the storage equipment.

Supplier's workforces shall be trained to carry out installation and have the necessary industrial experience to do so safely. If it is specified that the installation work is not to be carried out by the supplier then the supplier shall provide written assembly and installation instructions on the basis that the level of competence of the installers is equivalent to that of the supplier's workforce.

If the user or the user's sub-contractor and not the supplier carry out this work, it shall be done strictly according to the instructions provided by the supplier.

6.2 Installation quality and structural design

The installation tolerances affect the carrying capacity of the structure and should be in accordance with EN 15620 for APR unless otherwise specified by the designer.

6.3 Aspects of installation work to be observed

Aspects of installation work to be observed include the following:

- a) all storage equipment shall be fixed to the floor to prevent movement of the uprights where mechanical handling equipment is used at or near to the storage equipment. The number and type of floor fixings shall be specified by the storage equipment supplier and these shall be installed in accordance with the instructions of the fixing supplier;
- b) back or spine braced bays of racking or shelving provided for longitudinal (down aisle), stability shall be installed and anchored to the floor in accordance with the supplier's requirements. Bracing, when supplied, shall be installed in accordance with the manufacturer's instructions at all specified positions and shall not be removed or repositioned;

NOTE Where spine bracing and associated plan bracing is incorporated in a racking or shelving design, this is fundamental to the carrying capacity of the product.

- c) single run, single tier hand loaded shelving systems without drawers and with a height of less than 2,5 m or single tier double runs less than 4,0 m in height, need not comply with the requirement regarding floor fixings if the ratio between height to topmost loaded shelf and overall depth is less than 4:1;
- d) base plates shall be in contact under their entire area with the floor of the building or any prepared plinth. The base plates shall be packed up with suitable steel shimming or grouting under the whole of the plan area of the base plate. Steel shims should be permanently located under the base plates or, if preferred, sufficiently strong and shrink-proof mortar can be injected under the base plates to fulfil a similar function. Specialists in this type of operation shall carry out the grouting;
- e) when upright frames used for APR are coupled back to back in double runs at least two run spacers shall be provided. The position of the run spacer shall be as near as possible to a bracing node point to prevent local upright damage by bending if there is truck impact or a frame is damaged by other means. The number and location of the row spacers shall comply with the following minimum requirements:
 - 1) lower run spacer – next to the second lowest horizontal bracing, and in the absence of horizontals next to the second lowest bracing joint (see Figure 1);
 - 2) upper run spacer – next to the highest horizontal bracing member adjacent to a diagonal (see Figure 1);
 - 3) if applicable, a run spacer adjacent to a splice on spliced uprights;
 - 4) if the minimum requirement of two run spacers is fitted, the optimum positions are shown in Figure 1.

NOTE Run spacers fitted in these two positions provide some lateral support for accidentally damaged frames, however, while they can be of help they cannot be guaranteed to prevent the collapse of double runs.

- f) spacing of beams, cantilevers, shelving, etc. shall not be greater than values given by the rack supplier that correspond to their maximum loads or the maximum allowable load on the upright frame as shown on the safe load warning notice;
- g) beams shall be locked in position as prescribed by the rack supplier;
- h) safe load warning notices shall be in position.

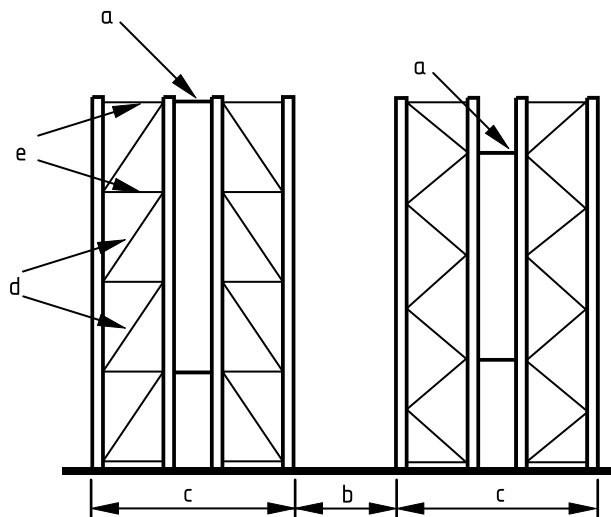

Key

- a run spacer
- b aisle
- c double run rack
- d frame diagonals
- e frame horizontals

Figure 1 — Location of run spacers

7 Changes to the storage equipment configuration

Changes in the safe carrying capacity can occur when the storage equipment is modified. In all cases of changes the supplier or an appropriate expert shall be consulted and any advice received shall be followed before any alterations are made.

Changes shall be made in accordance with the supplier's instructions which shall contain the following:

- a) rack shall be unloaded prior to carrying out the alterations;
- b) additions or changes to the storage equipment by welding or bolting shall not be allowed unless specifically approved by the equipment supplier;
- c) safe load warning notices shall be updated as necessary after all changes to rack configuration;
- d) position of the bracing node points shall be changed if beam positions are changed in racking where back bracing is present. This can also require the repositioning of any horizontal bracing, which can be fixed between some beams (see Figure 2).

NOTE 1 Changes in the safe load carrying capacity of the storage equipment can occur if it is relocated since changes in the floor conditions providing support for the equipment can cause changes in load capacity.

NOTE 2 Changes in the rack or shelving configuration will generally cause a change in the load-carrying capacity of the rack. In braced or un-braced racking, if the height to the first beam level, or the spacing between beams, is increased, the safe load capacity of the frames will be reduced.

NOTE 3 Storage structures that are braced down aisle will always have a higher load-carrying capacity than an identical un-braced structure built of the same components. The removal or faulty rearrangement of any bracing provided will substantially reduce the load carrying capacity of the installation.

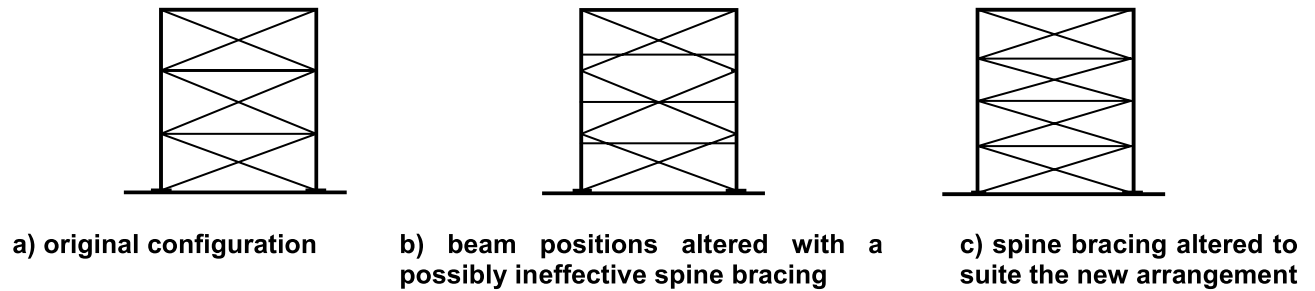

Figure 2 — Changes to beam configuration may require changes to the vertical bracing

8 Use of the storage equipment

8.1 General safety

8.1.1 Person responsible for storage equipment safety PRSES

The user shall appoint a person responsible for storage equipment safety and the name of that person should be publicized to the warehouse staff. The PRSES shall be instructed to identify the supplier(s) of storage equipment, contact the supplier(s) and identify the training necessary to keep the storage equipment in a safe working condition.

The PRSES shall be aware of the nature of the operations in the warehouse (see 4) and the associated dangers on the basis of a risk assessment, as well as the precautions that are taken to prevent or limit the dangers, by means of instructions and/or signs.

8.1.2 Safe load warning notices

Instructions with regard to the safe load capacity shall be displayed in a prominent location on or adjacent to the storage equipment so that they are clearly visible, in the national language and in a durable format. Where necessary, the instructions should be displayed in such a way that persons with inadequate knowledge of the national language could also understand them (see Annex B.) The safe load capacity of storage equipment is based on good practice in the placement and retrieval of unit loads.

8.1.3 Training

Operators shall receive adequate training in the use of the storage and handling equipment (see B.3).

NOTE Truck drivers employed should be certificated/licensed.

8.1.4 Access to storage levels

Safe access equipment shall be used for gaining access to storage levels above ground level. Standing or climbing on the racking or shelving shall not be allowed.

NOTE This does not apply to construction or repairs where a specific risk assessment and safety precautions apply.

8.2 Pallet or load carrying accessories

8.2.1 Loading

The pallet shall not be loaded beyond its rated capacity.

8.2.2 Pallet requirements

The pallet type, dimensions, tolerances, quality and design shall be suitable for the safe operation and storage on the particular storage equipment. Damaged load makeup accessories shall not be used (see Annex C).

The specification of pallets used in drive-in racking shall include for a quality of pallet which, when loaded with the specified goods to be stored does not deflect by more than 25 mm when supported on the beam rails with a minimum bearing on one side of 20 mm and a pallet span equal to the nominal clear dimension between the rails.

NOTE 1 Drive-in racking and live storage systems are particularly sensitive to the type and condition of pallets and inferior or damaged pallets can cause safety problems.

NOTE 2 Damaged pallets (see Annex C) or the failure of a pallet at a high level in a storage rack can be dangerous to any person in the vicinity and can cause disproportionate damage to the storage system.

NOTE 3 Advice on suitable pallet types can be obtained from prospective suppliers.

8.2.3 Special load make up accessories and loads

In the case of steel pallets with feet, pallet foot supports shall be used (see Figure 3). Special loads such as drums, coils of wire, barrels, etc., shall be supported by the correct accessories provided by the original storage equipment supplier.

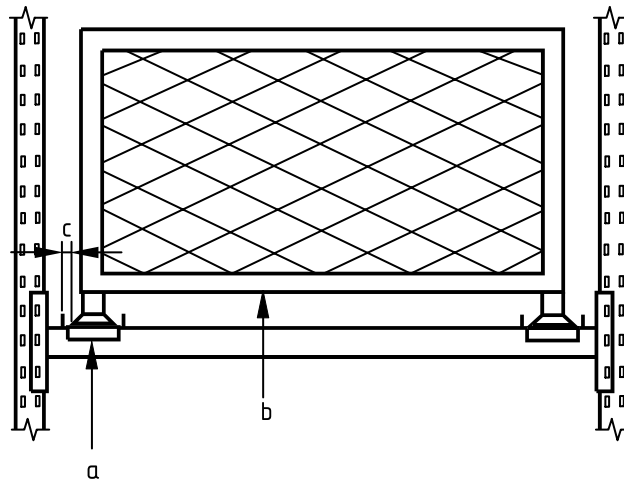

Key

- a pallet foot support
- b cage pallet or stillage
- c clearance between pallet foot and side of foot support

Figure 3 — Cage pallet or stillage supported on pallet foot supports

8.2.4 Precautions necessary for the use of weak pallets and pallets spanning in the incorrect direction

Precautions shall be used for pallets (e.g. disposable pallets) that have insufficient strength to span between supporting beams or beam rails. Examples of such precautions are the use of:

- a) additional pallet support bars;
- b) decking of a compartment to form a supporting shelf;
- c) slave pallet to support a weak pallet.

NOTE In manually operated systems where the positioning of LMA's can vary by more than ± 50 mm in the down aisle direction due to depositing tolerances (e.g. pallets with and without overhang), the position of pallet support bars should be sufficiently visible to allow easy operation by the MHE operator

8.3 Unit load

8.3.1 Weight

Heavier unit loads than those prescribed by the specifier and shown on the load warning notice shall not be placed in the storage system.

8.3.2 Load stability

The goods shall be stacked or palletized such that they are stable.

8.3.3 Unit load clearances

The actual dimensions of the unit loads (see Figure 4) shall not adversely affect the clearances provided for safe operation. (see EN 15620)

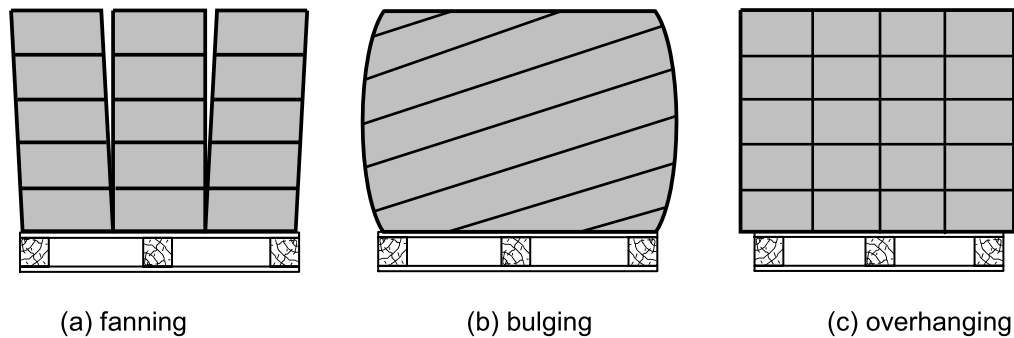

Figure 4 — Characteristics of palletized unit loads that can affect the placing of unit loads

8.4 Unit load handling

8.4.1 Placement of loads

Load makeup accessories shall be loaded into, and picked from, racking with care by trained personnel using the correct type of handling equipment. This shall be carried out in accordance with good practice. It shall be ensured that the loads placed on the storage equipment are the same as those specified.

NOTE 1 The level of consistent accuracy of placement of the pallets both into and out of the system is dependent on training, practice, motivation and supervision, which also have a direct effect on the level of damage in the racking installation.

If the method of placement of the loads is to be altered from that specified to the supplier, then the supplier or an appropriate expert shall be consulted about the consequences. Placement loads can vary if the mechanical equipment is changed.

NOTE 2 Additional unregulated forces can be imposed on the storage equipment caused by faulty loading operations (e.g. pallet drag on beams, or deliberate use of pallet safety backstops to position load make up accessories, etc.).

NOTE 3 Pallet buffer back stops should not be used; they are not a substitute for a well designed rack (see prEN 15512) and rack layout (see EN 15620) combined with good house keeping, warehouse practices and the use of adequately trained and instructed truck drivers.

8.4.2 Damage to storage equipment

Mechanical handling equipment shall be carefully driven and shall only transport the specified unit loads. Any accidental or other damage that does occur shall be reported immediately to the PRSES by any person who observes or causes it (see 9.4.2.1 and Annex D).

8.4.3 Timber pallet usage

Timber pallets shall be placed in a rack such that the pallet bearers span the space between beams, beam rails or cantilever arms. In this context, a bearer may be a one-piece member or a composite construction of top board, bottom board and blocks. Timber pallets shall be supported directly under their blocks to prevent breaking of the bottom boards and a collapse of the pallet.

8.4.4 Load make up accessory positioning on supports

Pallets shall be correctly orientated (see Figure 5), correctly positioned on the storage equipment supporting members and shall make proper use of any load support accessories provided.

Load make up accessories shall be placed symmetrically with respect to a pair of APR beams in the front to back direction or on drive-in racking (DIR) beam rails in the left to right direction.

NOTE In general for APR, a normal overhang from the face of the beam of the wooden pallet or other storage medium will be 50 mm (see EN 15620).

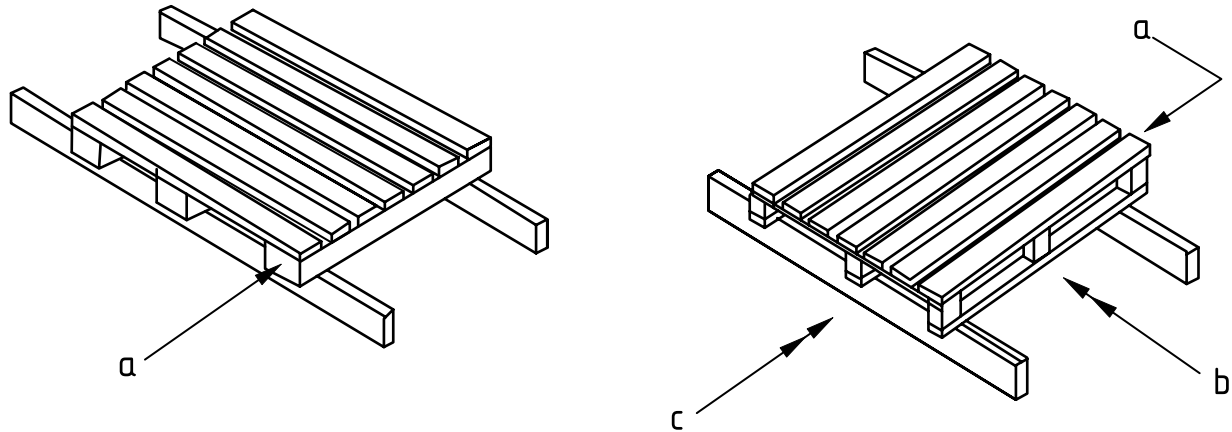

(a) pallet where bearers are solid one piece members

(b) pallet where bearers are a combination of a top deck and bottom boards separated by pallet blocks

Key

- a bearer,
- b entry direction of drive in racks,
- c entry direction of adjustable pallet racks

Figure 5 — Pallets with their bearers spanning in the correct direction between beam rails

8.4.5 Pallet positioning on the floor

The front face of the load make up accessory or its load shall be placed in such a manner as not to protrude into the operating width of the aisle.

NOTE Where the lowest load make up accessory in a rack is supported on the floor, a permanent line drawn down each side of each aisle to mark this position can help to control this issue.

8.4.6 Aisle obstructions

Aisles shall be kept free and goods shall be placed in the racking such that they do not form an obstacle.

8.4.7 Handling on raised storage areas or on storage equipment supported floors

8.4.7.1 Pallet access for raised storage areas

Purpose designed pallet gates shall be used for personnel safety (see Figure 6).

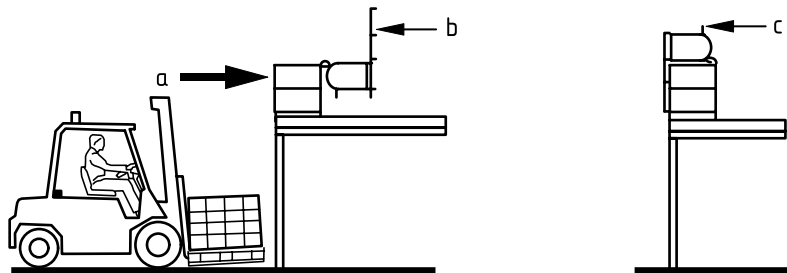

Key

- a fork truck access
- b pallet gate closed for personnel access, open for truck access
- c pallet gate closed for truck access, open for personnel access

Figure 6 — An example of a raised storage area pallet gate and on-load or off-load point

8.4.7.2 Types and loading of MHE

The raised storage area shall not be used by MHE for which it has not been designed and this information shall be displayed on a load warning notice.

8.4.8 Operating aisle clearances

The operating aisle width shall allow sufficient clearance for safe operation. For narrow aisle APR (see Figure 7) and for further information see EN 15620 and data sheets relating the MHE.

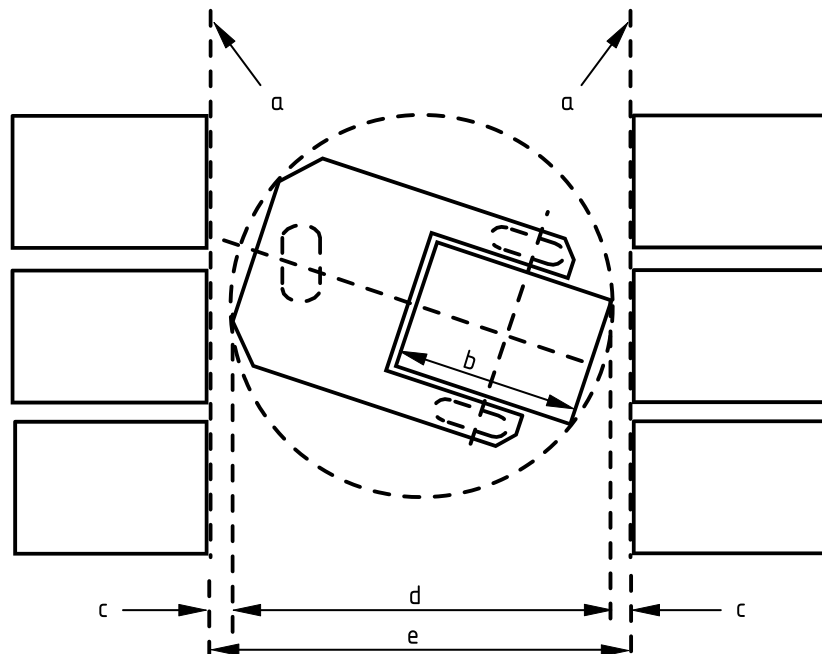

Key

- a positioning line marked on the floor
- b maximum plan dimension of pallet or load
- c clearance
- d diameter of turning circle for truck and load
- e clear operating aisle width

Figure 7 — Example of clear operating aisle width for a narrow aisle system

8.5 Placement on adjustable pallet racking

When a LMA is placed into APR, the loading sequence shall ensure that there shall be no contact with the rack structure or a unit load already stored during the placement or retrieval operation, the sequence being as follows:

- a) fork lift truck drives with a pallet and takes up position in front of the vacant storage location;
- b) LMA shall be lifted clear of the top of the support beam;
- c) forks shall be horizontal;
- d) LMA shall be positioned concentrically in the depth of the rack with regard to the pallet beams;
- e) LMA shall be carefully lowered onto the beams. Once in contact with the beams the LMA shall not be slid or dragged across the supporting members.
- f) after placement the fork entry of the LMA shall be visible to the truck operator.

Any requirements for specialised equipment shall be implemented.

8.6 Placement in drive-in racking

8.6.1 Placement

Drive in racking structures should not be considered as providing any pallet or truck mast guidance.

When a pallet is placed into a drive-in rack, the loading sequence shall be as follows:

- a) fork lift truck drives with a pallet and shall take up position centrally in front of the storage lane;
- b) pallet with no forward tilt on the forks shall be raised to the required storage level;
- c) pallet shall be lined up with the racking lane using side shift, clear of the rack uprights, and with the pallet load positioned centrally between the uprights or guardrails;
- d) truck shall be driven forward from the entry to the set down position keeping the pallet and truck mast clear of contact with the guardrails or other parts of the drive-in rack structure;
- e) pallet shall be carefully and centrally lowered onto the guardrails without touching other pallets, or other parts of the drive in structure and the load released from the forks. Once in contact with the guardrails, the pallet shall not be slid or dragged along or across these supporting members;
- f) drive-in racking fitted with integral or non integral sloping side guards shall be loaded and unloaded as shown in the sequence illustrated in Figure 8;
- g) forks shall be removed from the pallet, as the truck carefully reverses from the lane and then lowers the forks.

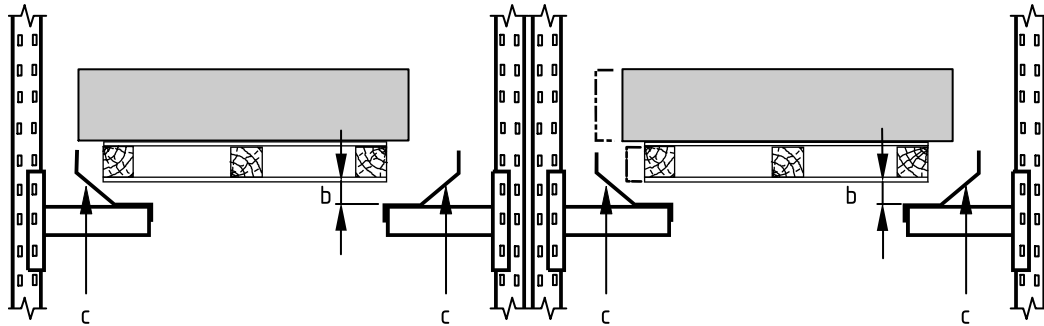

(a) raise pallet to correct storage level at entry to the lane

(b) centralise the pallet between the guardrails at entry to the rack then drive the truck to the set down position

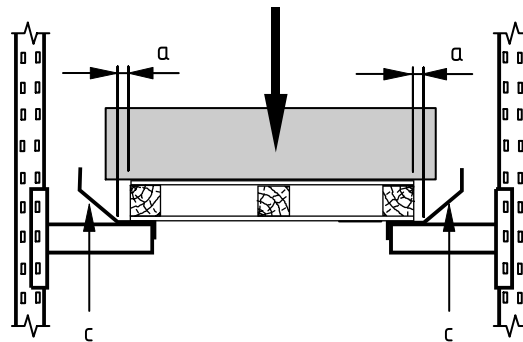

(c) at set down position, place the pallet centrally

Key

- a positioning clearance of the pallet between guardrails
- b sufficient clearance
- c example of a guard integrated into the beam rail

Figure 8 — Correct sequence of loading for types of drive-in systems with guardrails

8.6.2 Loading and unloading sequence for drive-in-racking

In drive-in racking the sequence of placement of loads shown in Figure 9a) and 9b) shall be followed. On the input cycle the first pallet is placed at position 1 and the rack is loaded from the bottom upwards and from the back outwards. On the output cycle the procedure is the exact reverse, from the top down working in towards the back of the drive-in rack. A truck shall not drive under a pallet load supported on the beam rails.

The minimum pallet bearing in the worst case on a beam rail with the pallet in the extreme position on one side shall be 20 mm (see Figure 10).

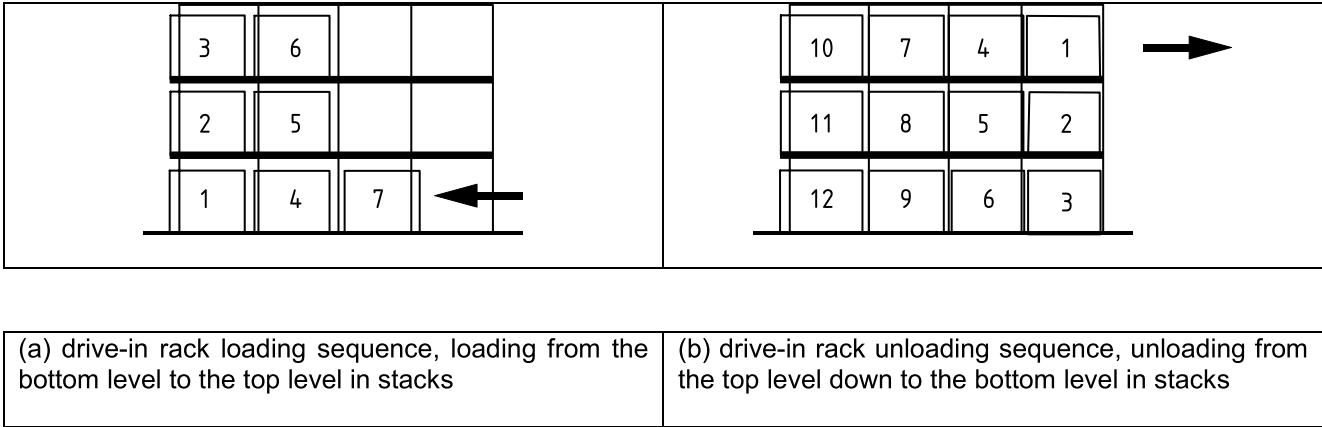

NOTE Drive-through racking can be loaded from one side and unloaded from the other side.

Figure 9 — Loading –Unloading sequence for drive in racking

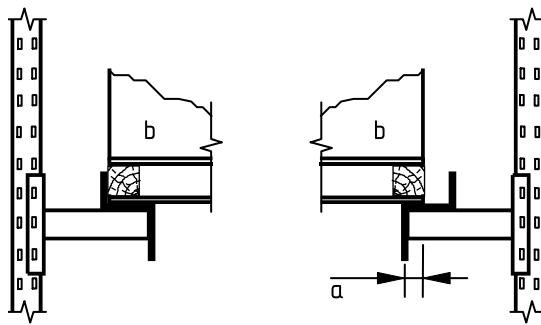

Key

- a minimum 20 mm pallet bearing in the worst case on a beam rail with the pallet in the extreme left position
- b load

Figure 10 — Minimum safe bearing of a pallet on drive-in racking beam rails with the pallet at the extreme left position

8.6.3 Use of drive-through racking access routes by trucks

The lanes of drive-through racking are designed for pallet placement or retrieval; they are not designed to be used as through access routes. The gangways provided, as necessary, between rack blocks or at the ends of racking blocks, are for this purpose.

8.7 Truck mast stiffness and floor flatness

The stiffness of the truck mast and the degree of wear in the mast mechanism, in combination with the degree of floor flatness and levelness in a lane, shall be maintained to avoid excessive sway to cause any part of the truck or its load from striking the racking.

9 Safety of storage equipment in use and evaluation of damaged components

9.1 Procedures

A management procedure shall exist that covers at least the following:

- a) use the storage system in accordance with its specification;
- b) appoint a PRSES (see 8.1.1);
- c) carry out inspections (see 9.4);
- d) carry out maintenance (see 9.7.1);
- e) damage reduction (see 9.7.3).

9.2 User's responsibilities

The storage equipment user has responsibility for the safety of persons working in the vicinity of the equipment and for the safe working condition of the equipment in use. The safety in use of storage equipment serviced by fork lift trucks or other material handling equipment requires the application of risk analysis techniques. This is because of the severity of the damage that can be inflicted on the racking components by accident, or by the faulty use of the handling equipment, combined with the usually considerable weight of the unit loads that can fall as a consequence of damaged rack members.

Where material-handling equipment is used, safe-working conditions shall be established by the user on the basis of the risk analysis to minimize the chances of damage to the storage equipment. Safety can be improved by operator training and by avoiding conditions that give rise to difficult working conditions. The following is a non exclusive list of points that the user shall comply with or consider:

- a) observance of national and local regulations (e.g. fire safety);
- b) provision of personnel, trained in the use of materials-handling equipment and the storage capabilities of the racking or shelving, to operate the storage facility safely;
- c) confirming the environment is in accordance with the specification, e.g. dry, unpolluted, internal or external location exposed to wind and weather, which defines the quality and durability of the paint or other steel surface treatment required. Any spillages in the racking environment shall be cleared up immediately;
- d) overall dimensions and weight of the unit load shall not exceed the limitations in the specification on which the storage equipment has been designed. This ensures that the unit load handling clearances are sufficient for safe unit load manoeuvrability so that the chance of collision between loads or between load and storage equipment is minimised;
- e) suitability of the handling equipment employed including ensuring the turning radius of the lift truck shall not exceed the radius on which the rack layout has been designed. This ensures that the aisle operating clearances are sufficient for safe truck manoeuvrability;
- f) load make up accessory for unit load shall be as specified for the design and is in good condition, also the goods carried on the pallet are stable and within the unit load width tolerance agreed for the design taking into account any variation in conformity which is critical in the case of drive-in racking;
- g) good housekeeping of the truck aisle operating area shall be maintained, ensuring that these critical areas are clear of unintended obstacles;
- h) ensuring that the equipment is used in accordance with the contract specification supplied;

- i) recognizing that there are safety implications in any alterations to the storage system;
- j) provision of a management system that allows different design loads to be calculated for differing configurations of compartment loads, bay loads or runs of bay loads;
- k) ensuring that the detailed assembly and installation erection instructions provided by the storage equipment supplier are correctly implemented when the installation of the equipment is undertaken by the user or a contractor appointed by the user (erection of equipment by the supplier or manufacturer is always the preferred option);
- l) consideration of the rack "foundation" properties to ensure that there is sufficient strength and stiffness to carry the loads and also for identifying any special requirements of any surface layer, floor fixing limitation, surface flatness, etc.;
- m) confirmation, if applicable, that the site location for the calculation of wind, snow and seismic loads is correct;
- n) providing appropriate heating and lighting over the storage area;
- o) ensuring that upright protection is provided where necessary;
- p) regular inspections of the racking or shelving structure shall be carried out during its life including explanations of the 'Green' 'Amber' and 'Red' damage levels to ensure that any damage requiring immediate action is dealt with urgently normally by the replacement of damaged component with identical new parts from the same manufacturer.

NOTE Commentary is provided in Annexes A to E that is intended to provide relevant, detailed background information on the application of certain clauses of the document where this may be helpful to the user.

9.3 Reduction of safety level (margin of safety) due to damage

Users should be aware of the fact that damage will erode the stated design safety factors and reduce the load carrying capacity. A regime of careful regular monitoring and maintenance will control this and will mitigate the problems that arise. All damage shall be identified and rectified promptly.

NOTE A collapse of all or part of a damaged rack may not necessarily be immediate, but can take place over a period that can be several hours or even days. The time taken from initial damage to collapse depends upon the severity of the damage to a component, the location of the damage, the load capacity and the load actually being carried by the component, etc. (see Annex D).

9.4 Inspection of storage equipment

9.4.1 General

Storage equipment shall be checked regularly for safety and specifically for any damage that has occurred. Repairs shall be carried out in a timely and effective manner with due regard for the ongoing safety of the system since this is the basis of design. Records shall be maintained of all damage or other safety problems found and evaluations carried out as part of a damage reduction procedure.

The main structural issues for inspection shall be:

- a) impact damage to any part of the structure, particularly upright damage and beam damage;
- b) out of verticality of the uprights;
- c) condition and effectiveness of all components particularly base plate and beam to upright connections;
- d) cracks in welds or parent material;

- e) condition of the floor of the building;
- f) position of the loads on the pallet;
- g) position of the load make up accessories on the racking and on the floor;
- h) rack is built in accordance with installation instructions

Other safety items that should be checked are that:

- i) load and information notices are present and up to date;
- j) no storage positions are overloaded;
- k) stability of the unit loads is satisfactory;
- l) dimensions of the unit loads are satisfactory.

9.4.2 Inspection

The inspection of all storage equipment should be done systematically on a regular basis and is normally carried out from ground level, which is where most of the damage tends to occur unless there are indications of problems that need investigation. If it is necessary to carry out a high-level inspection then a safe method of access shall be used in order to carry out the inspection. Free climbing shall not be allowed.

The frequency and extent of inspections depends on a variety of factors that are particular to the site concerned and should be determined by the PRSES to suit the operating conditions of the warehouse. This will take into account the frequency and method of operation together with the dimensions of the warehouse, the equipment used and personnel involved, all of which could damage the structure. The inspection follows a hierarchical approach utilizing several levels of inspection.

NOTE It is not normal to require the removal of load make up accessories to carry out a full rack inspection as areas that cannot be seen during one examination will be visible at various times during subsequent examinations. The occupation factor may cause the PRSES to call for more frequent examinations of racking that are operating regularly at almost full capacity.

9.4.2.1 Immediate reporting

As soon as safety problems or damage is observed by any person it shall immediately be reported to the PRSES.

All persons shall therefore receive formal instruction on the safe operation of their system affecting their safety and the safety of others.

9.4.2.2 Visual inspections

The PRSES shall ensure that inspections are made at weekly or other regular intervals based on a risk assessment. A formal written record shall be maintained.

9.4.2.3 Expert inspections

A technically competent person shall carry out inspections at intervals of not more than 12 months. A written report shall be submitted to the PRSES with observations and proposals for any action necessary.

9.4.3 Inspection of automated systems

Automated systems, while less prone to damage at high level, require inspection and the higher levels cannot be seen from the ground. Formal inspection of these systems shall include the following:

- a) immediate written reporting system by maintenance staff who shall have day to day responsibility for the system to ensure that the quantity and scale of any problems can be analysed by the PRSES;
- b) expert inspection every 12 months consisting of a minimum of 20 % of the installation carried out on a rolling basis so that the complete installation is inspected every 60 months;
- c) appraisal of the problems found by the inspection should be carried out by the PRSES to identify if a more wide ranging inspection is necessary.

9.4.4 Damage investigation

Any damage shall result in an investigation of the potential causes of the problem with the intention of reducing or eliminating the possibility of the problem and the damage reoccurring. Appropriate actions shall be taken accordingly.

Conclusions shall be reached, where possible, on the reasons why damage has occurred, such as but not limited to:

- a) faulty lift truck operation;
- b) quality of driver training or retraining;
- c) changes to the original handling equipment;
- d) poor condition of the handling equipment;
- e) changes to the original type or quality of pallet use;
- f) damaged load make up accessories;
- g) overhanging load on load make up accessories;
- h) clearances are too small;
- i) aisle width is too small;
- j) poor housekeeping – spilt goods, load make up accessories obstructing aisles, etc.;
- k) poor lighting;
- l) flooring inadequacies.

9.4.5 Damage control procedures

A management procedure shall require an inspection report of rack damage to initiate the isolation and making safe sections of racking that are red risk (see 9.5.4 and 9.7) after which, repair procedures shall be commenced.

9.4.6 Inspection for overload damage to beams, cantilevers or shelves

A beam, cantilever or shelf shall be deemed overloaded if permanent deformation has occurred or if the deflection is more than the specified deflection.

NOTE Overloading can occur with smaller deflections than those given below.

Typical deflection limits may be the following; however, the specification should be referred to for exact details:

— L/200 in the case of pallet racking beams and steel shelves (see Figure 11);

— $L/100$ in the case of a cantilever.

Where L = span of the load carrying component.

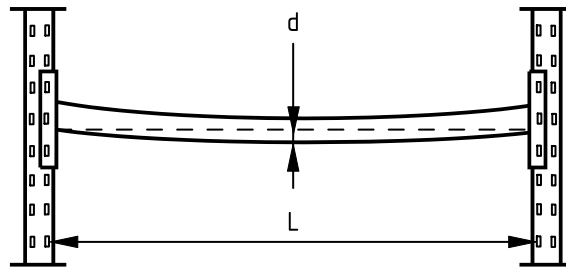

Key

L span of the load carrying component

D mid span deflection

Figure 11 — Beam deflection

9.4.7 Inspection of beam connector locks

The presence of the necessary locking devices shall be checked during inspection and repair. Any missing locking devices shall be replaced immediately to prevent accidental dislodging of beams. A supply of beam locking devices shall be held in stock on site (see Figure 12).

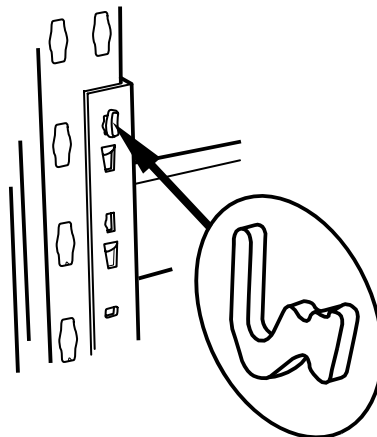

Figure 12 — Example of beam connector with lock used in adjustable pallet racking

9.4.8 Inspection of frame uprights for out of verticality

For all shelving and forklift truck rack installations the out of verticality under load shall not exceed $1/200$. Any displacement in excess of this level shall be referred to the supplier for a design check.

NOTE 1 In some racking systems (e.g. automated or very narrow aisle systems) this limit will be much less.

NOTE 2 Consideration should also be given to any increase in floor deformations caused by consolidation and settlement of the ground under the slab under load. It should be noted that storage equipment may become unsafe with quite small deformations of its floor foundation.

NOTE 3 In the case of cantilever racking uprights the lateral deflection under vertical load affects the out of verticality substantially (see Figure 13). The supplier should be contacted for further information.

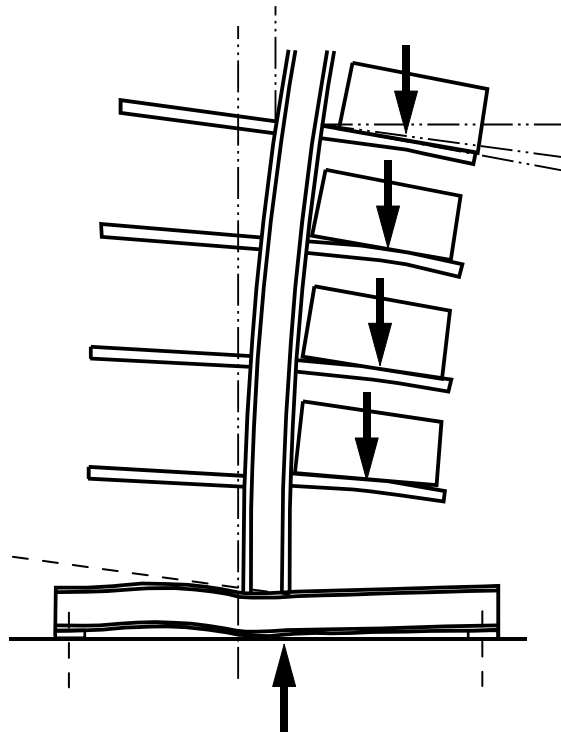

Figure 13 — Cantilever rack deflections

9.4.9 Inspection of guidance systems for VNA trucks

Any mechanical guidance for the truck which is attached to the floor or to the racking itself shall be considered within the racking inspection requirements; however any inspection of electrical systems such as an induction loop system which are in or on the floor shall be the requirement of the truck inspection process.

9.5 Rules for the measurement and classification of damage to uprights and bracings

9.5.1 Measuring method for upright damage and residual deformation limits, typical for APR systems

These rules apply only to damage that produces an overall bend in a member (see Figure 14). They do not apply to highly localized damage such as dents, buckles, tears and splits. Localized bends over a length of less than one metre may be judged pro rata to the 1,0 m limits, e.g. over a half metre length half the prescribed limits apply. Members subjected to tears and splits should always be replaced. Measurement of damage shall be carried out as follows:

- straight edge 1,0 m long is placed in contact with a flat surface on the concave side of the damaged member such that the damaged area lies central, as near as possible, to the length of the straight edge;
- for an upright bent in the direction of the rack beam spans, the maximum gap between the upright and straight edge shall not exceed 5,0 mm;
- for an upright bent in the plane of the frame bracing, the maximum gap between the upright and straight edge shall not exceed 3,0 mm;
- for an upright that has been damaged such that there is a simultaneous bend in both longitudinal and lateral directions the left-to-right and the front-to-back deformation shall be measured and treated separately and the appropriate 5,0 mm and 3,0 mm limits observed;

- e) for bracing members bent in either plane, the gap between the straight edge and the bracing member shall not exceed 10,0 mm over a 1.0 m gauge length or pro rata for shorter bracings where a 1,0 m gauge length is not practical.

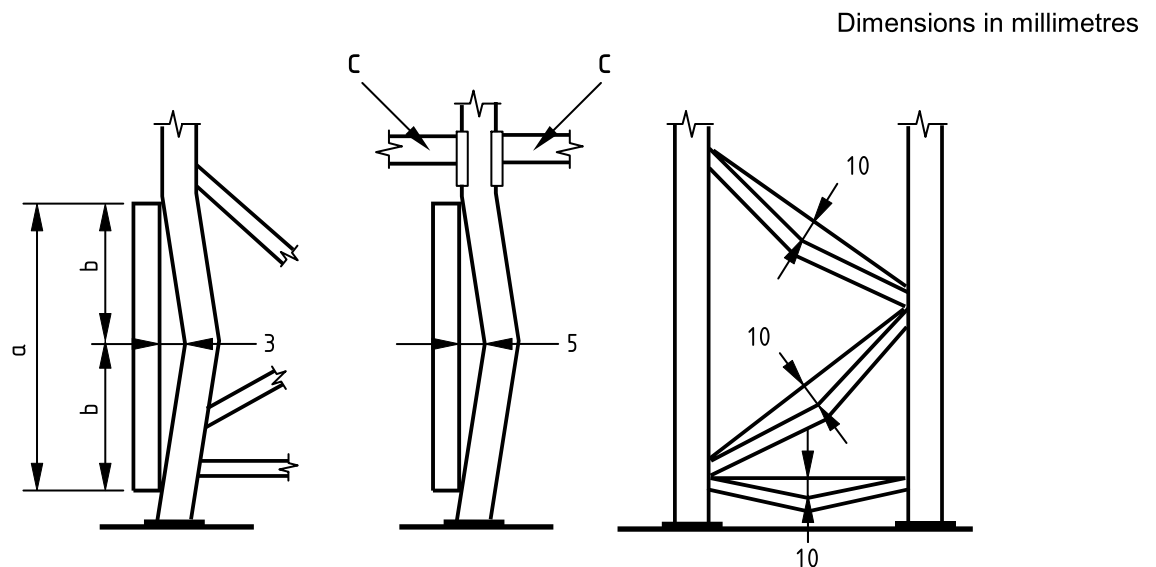

Key

- a gauge length 1000
- b half the gauge length
- c pallet racking beam

Figure 14 — Elevations showing method of damage measurement of typical adjustable pallet racking upright and bracing sections

9.5.2 GREEN LEVEL - requiring surveillance only

This category relates to cases where the limits of Figure 14 are not exceeded.

Green level indicates the limit that does not require a reduction in the rack carrying capacity as stated on the load notice or require repair of the system. This would indicate components of racking that are considered to be safe and serviceable. Such components shall be recorded as suitable for further service until the next management inspection but shall be clearly identified for specific re-examination and re-assessment at future inspections. Exceeding the green level causes risk to the racking system.

9.5.3 AMBER RISK – hazardous damage requiring action as soon as possible

This category relates to damage in which the damage limits of Figure 14 are exceeded by a factor of less than two and shall result in the replacement of the damaged component.

This would identify an area where the damage is sufficiently severe to warrant remedial work but not so severe as to warrant the immediate off-loading of the rack. Once the load is removed from a damaged component, the component shall not be reloaded until repairs have been carried out.

The user shall have a method of isolating such racks to ensure that they do not come back into use until the necessary repairs have been carried out and the equipment certified as safe. For example, use could be made of dated adhesive labels, which indicate racks that are not to be reloaded until rectified. Any racking with **AMBER RISK** category damage should be re-designated **RED RISK** damage if remedial work has not been carried out within four weeks of the original designation.

9.5.4 RED RISK – very serious damage requiring immediate action

This category relates to damage in which the damage limits of Figure 14 are exceeded by a factor equal or greater than two.

These are situations where a critical level of damage is identified, which warrants an area of racking being immediately off-loaded and isolated from future use until repair work is carried out. Such repair work would usually be by replacement of the damaged item.

User companies shall have a method of isolating areas to ensure that they do not come back into use prior to the repair work being carried out.

NOTE For example, a particular bay could be off-loaded in the presence of the inspector and roped off to prevent further use.

9.6 Rules for the evaluation of damage to pallet rack beams

Beams will deflect under normal circumstances and loading conditions to a maximum limit of span/200. This deflection is elastic and should disappear when unloaded. This elastic deflection should not be confused with permanent (inelastic) deformation caused by overloading or impact damage as follows:

- a) residual vertical deformation, caused by accidental overloading, shall not exceed 20% of normal deflection under full working load. Beams showing greater residual deformation shall be unloaded and expert advice sought from the equipment supplier as this can indicate that the beam has been overloaded;
- b) residual lateral deformation, caused by accidental side loads or twisting under overload conditions, shall be measured at the top edge or the bottom edge of a beam and shall not exceed 50% of the normal vertical deflection under full working load. Beams showing greater residual deformation shall be unloaded and expert advice sought from the equipment supplier;
- c) beam end connectors that show any clearly visible deformation shall be unloaded and expert advice sought from the equipment supplier;
- d) welded connections between beam section and end connector shall show no signs of cracking. Beams or connectors showing any signs of cracking shall be unloaded and expert advice sought from the equipment supplier.

9.7 Damage action procedures

9.7.1 Replacement of damaged components

Repairs to damaged components shall not be allowed unless approved by the equipment supplier.

NOTE Damaged components should be replaced rather than repaired as effective quality control is difficult on cold formed materials.

9.7.2 Typical damage patterns

Evaluation of typical damage patterns shall be carried out in order to identify the cause which could help to minimize future damage (see 9.4.4).

9.7.3 Inspection procedure flowchart, Inspection – Evaluation – Action

All damage to racking should be subjected to an objective appraisal of its danger and potential for collapse (see 9.5 and 9.6) by the PRSES as soon as possible after the damage is discovered. Appropriate action shall be initiated using the flow chart in Figure 15 for guidance.

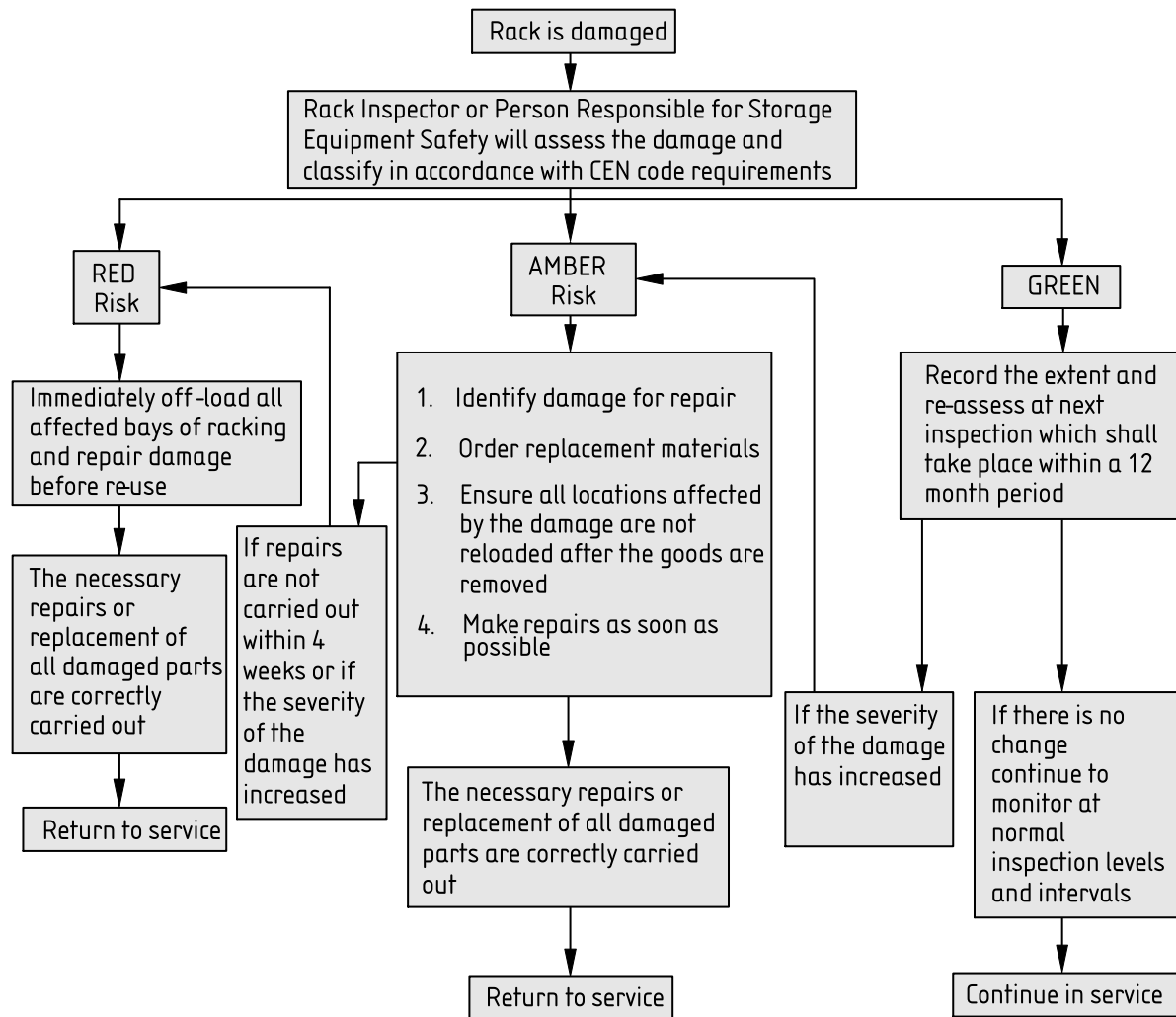

Figure 15 — Inspection procedure for damage classification

10 Changes that require a safety review of storage operations

A safety review of storage operations shall be carried out if the specification of the racking, unit load or mechanical handling equipment changes. A risk analysis of the effect of any changes should be carried out on each change and should be conducted by management at least on a yearly basis using the filed reports to assess the situation historically backed up by a physical on-site visual inspection to ensure the reported situation gives a representative indication of the continuing safety of the storage equipment.

The following is a non-exclusive list of changes that shall result in a safety review:

- a) change of type or make of truck;
- b) change in the method of handling unit loads or the pallet type used;
- c) change in the type of goods being handled;
- d) change in the weight or size of unit loads;
- e) introduction of overhanging loads on load make up accessories (see Annex E);

- f) increase in the amount of storage equipment damage being sustained;
- g) change in the personnel operating the equipment;
- h) change in the throughput of the storage system.

Annex A (informative)

Supplier's responsibilities

A summary of the supplier's responsibilities may be expressed as follows as a non-exclusive checklist for the specifier who should make the user aware of it in order to confirm that the system is appropriate to their requirement and safe to operate.

The supplier should:

- a) specify the technical limitations of the system in terms of its safe operating conditions and carrying capacity in the light of the specifier's requirement (see EN 15629). This may be done by the provision of a drawing or drawings detailing dimensions and the position of the racking with clearances and operating aisle widths shown. This will identify any specific features of the system such as imposed loads or non standard operating conditions, which have been incorporated into the design. Any load accessories provided will be identified;
- b) identify what rack protection equipment should be provided;
- c) identify any truck operating types or criteria of use that has been incorporated into the layout of the racking or the design of the structure;
- d) provide, if required, an installation service by a team of trained and experienced installers working under qualified supervision. This should include a formal post-installation check of the racking on completion of installation by a competent person and a formal handover certificate signed by a competent person presented to the client confirming that the work has been completed to the specified standard;
- e) specify the imposed loads due to the storage equipment on the warehouse floor;
- f) provide ongoing technical advice to the user of the racking particularly relating to the effects of change of use, change of load, or reconfiguration of the rack geometry to suit new requirements;
- g) provide advice to the user of the rack on the need for regular scheduled inspection routines and a formal maintenance programme to deal with any accidental damage that occurs;
- h) make available for purchase replacement components to allow effective repair and maintenance of the racking;
- i) supply load warning notices in approved safety colours providing information on the limitations of the system;
- j) provide information to the user on the safe use of the equipment.

Annex B (informative)

Examples of typical load warning notices

B.1 Load warning notices

These colour plates constitute load warning notices designed for use on storage equipment including: APR, cantilever; mobile racking and shelving; live storage; drive-in and mezzanine floors. Use of load warning notices is an important part of the safe operation and use of the equipment.

B.2 Load warning notice layout

Colours and symbols are in accordance with the Safety Signs and Signals Regulations. All load warning notices are produced in response to European Council Directive 92/58/EEC. Loading notations and text references are in accordance with manufacturers and structural design considerations (see Figure B.1).

NOTE Due to space requirements it may be necessary to split the load warning notice into two parts.

B.3 Training

Load notices provide important information for the safe use of the equipment. However, they are operational signs and as such the information on the actual sign has been kept to a minimum for clarity. Users of storage equipment should always consult the manufacturer of the product to establish safe operational practice and should adequately train all persons who will use the equipment.

B.4 Display

Load notices should be placed in a prominent location on, or adjacent to the equipment so that they are clearly visible.

B.5 Checking load warning notice information

Any doubt about load warning notice information should be referred to the supplier for clarification.

B.6 Equipment inspections

As part of the regular internal inspection routine, users should ensure that load warning notices are in place and are clearly visible. Rack inspectors will check for this when carrying out an inspection.

B.7 Sizes

For sizes and orientations see Table B.1.

Table B.1 — Recommended sizes and orientations for the load warning notices

Product/Equipment	Load warning notice size
Adjustable pallet, mobile and live storage racking (see Figures B2, B3, B4, B5, B6, B7 and B8)	A3 landscape
Shelving (see Figures B9, and B.10)	A4 landscape
Cantilever racking (see Figure B.11)	A4 portrait (A5 if necessary to fit upright)
Mezzanine floors (see Figure B.12)	A3 landscape
Drive in Racking (see Figure B.13)	A3 landscape

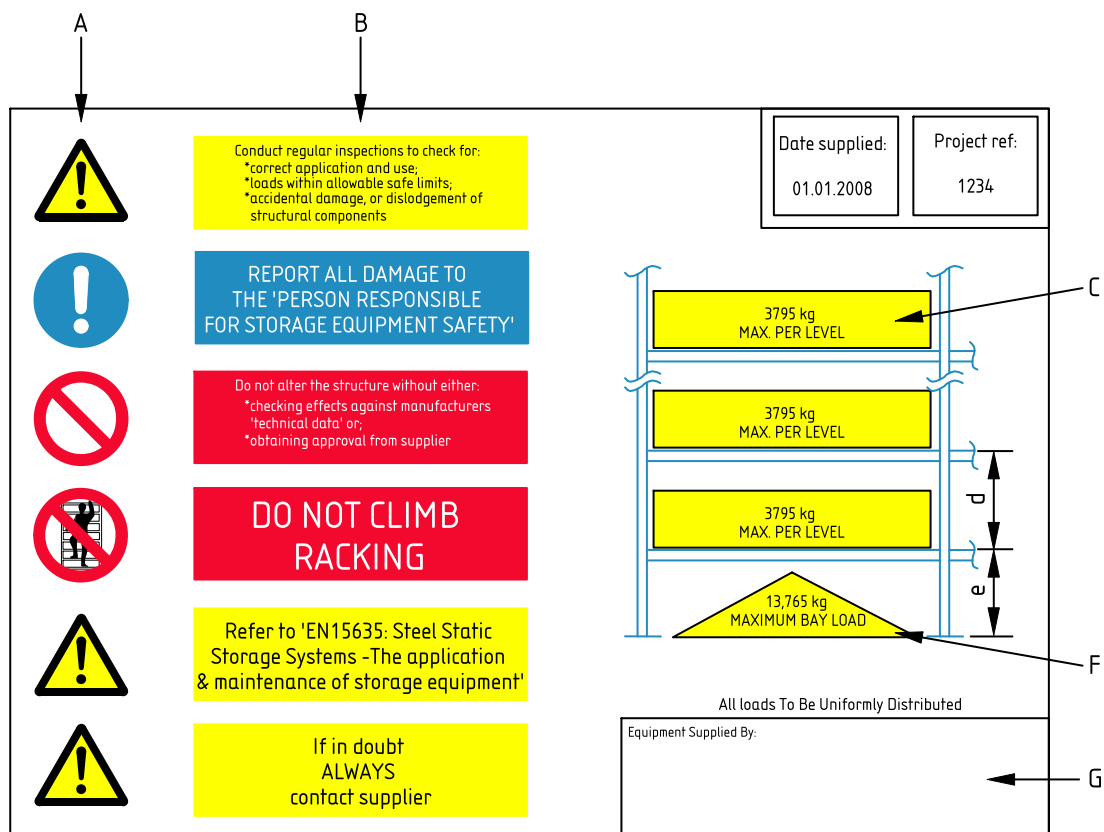

Key

- A symbols (shape and colour) in accordance with Safety Signs and Signals Regulations
- B brief explanatory commentary
- C maximum load per beam level
- d beam pitch
- e height to first beam
- F maximum load of the whole bay
- G space for supplier information e.g. name, logo etc.

Figure B.1 — Layout of load warning notice

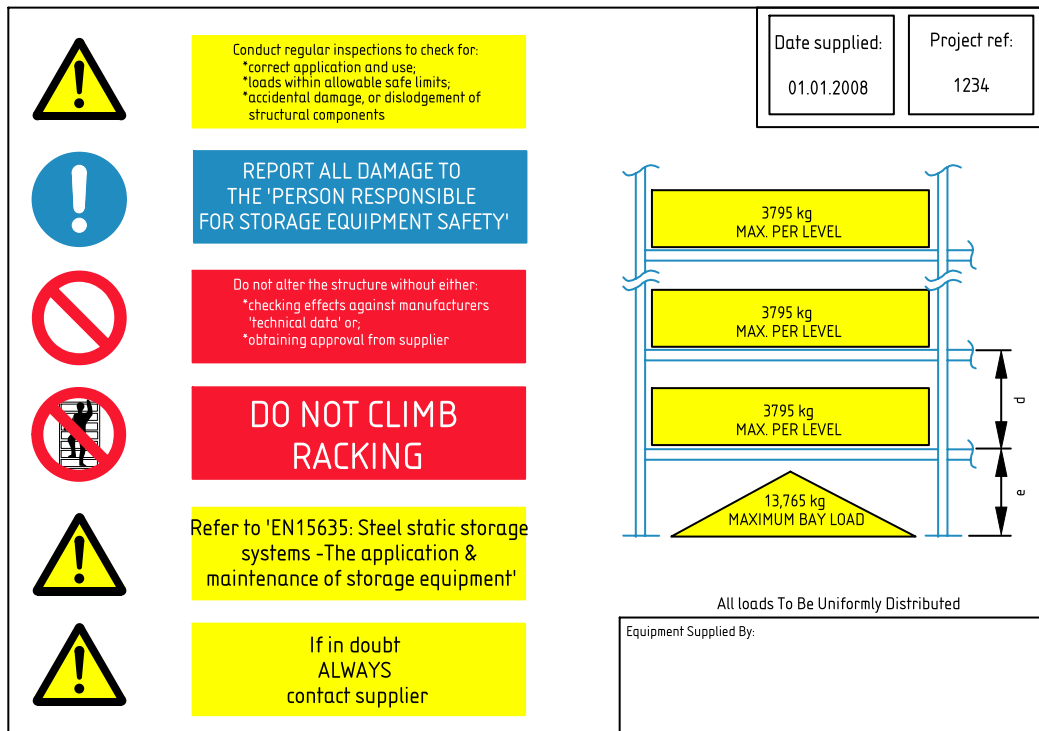

Key

- d beam pitch
- e height to first beam

Figure B.2 — Example: Load warning notice for adjustable pallet racking with a single unit load per pair of beams

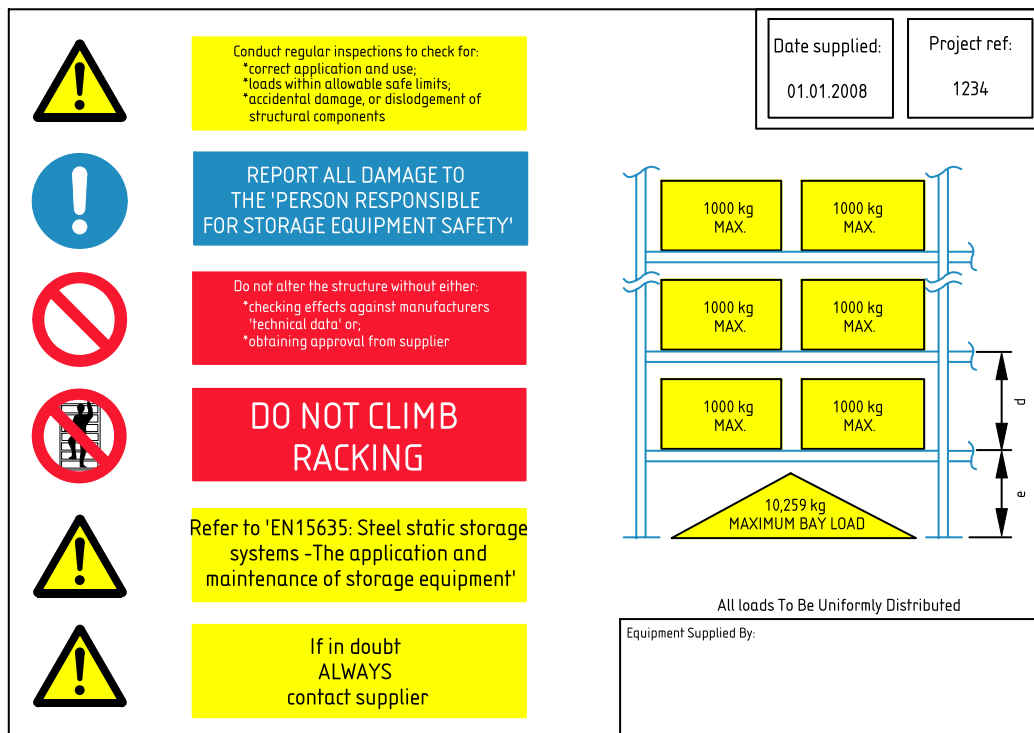

Key

- d beam pitch
- e height to first beam

Figure B.3 — Example: Load warning notice for adjustable pallet racking with two unit loads per pair of beams

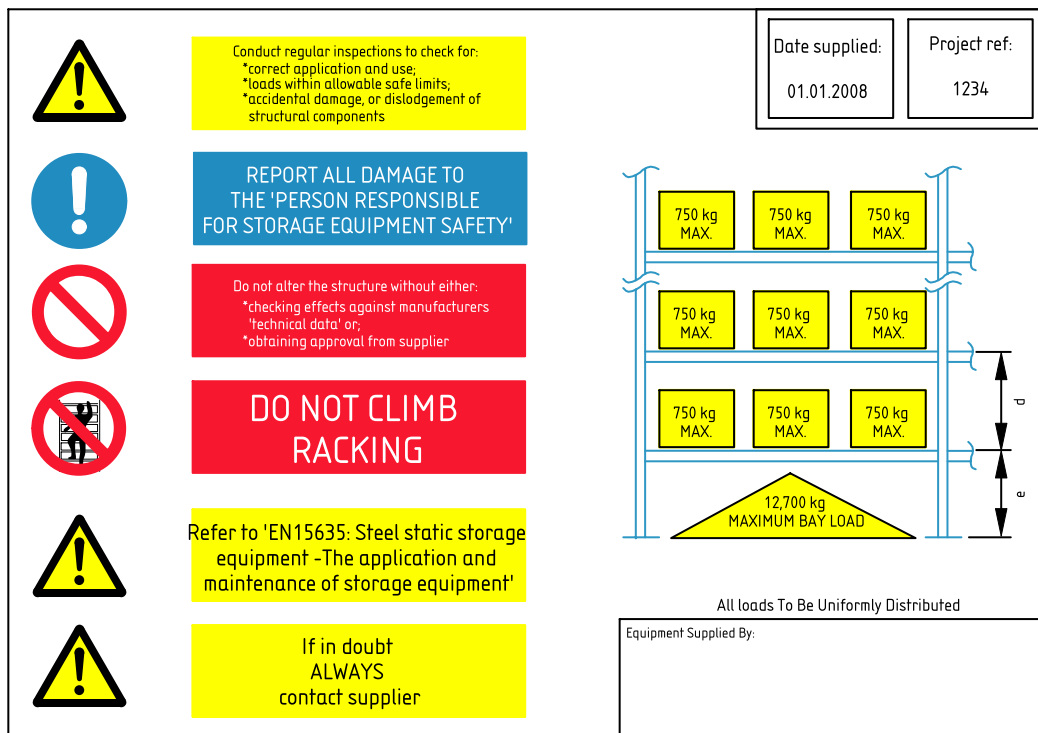

Key

- d beam pitch
- e height to first beam

Figure B.4 — Example: Load warning notice for adjustable pallet racking with three unit loads per pair of beams

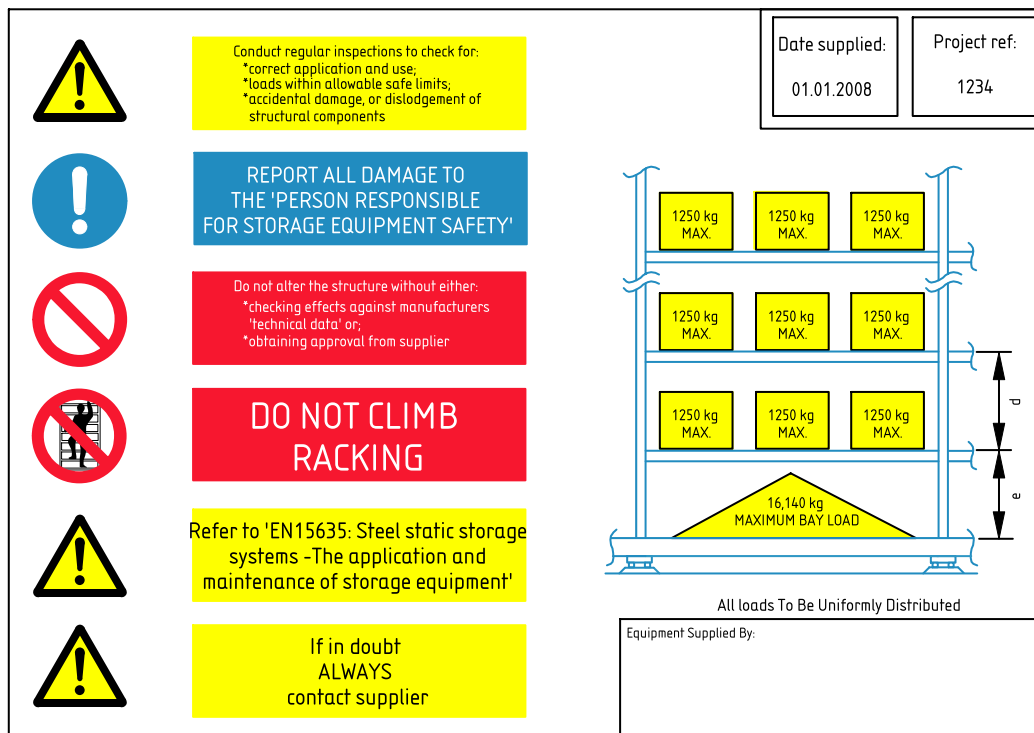

Key

- d beam pitch
- e height to first beam

Figure B.5 — Example: Load warning notice for mobile pallet racking with two unit loads per pair of beams

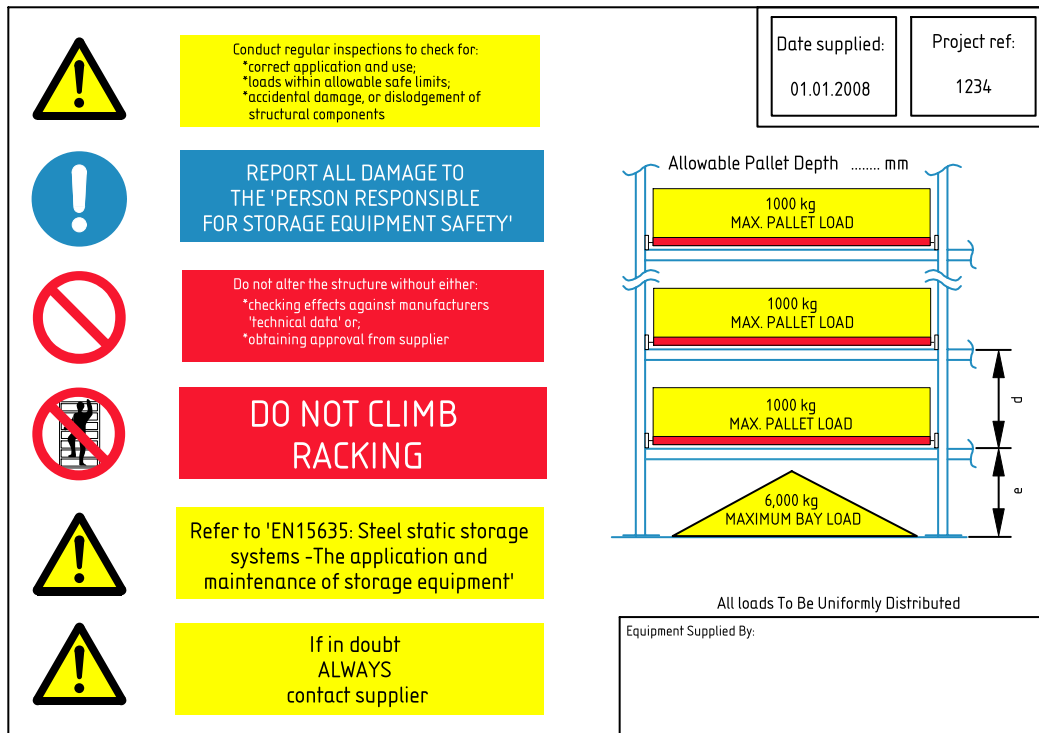

Key

- d beam pitch
- e height to first beam

Figure B.6 — Example: Load warning notice for gravity live storage or push back systems in single pallet lane configuration

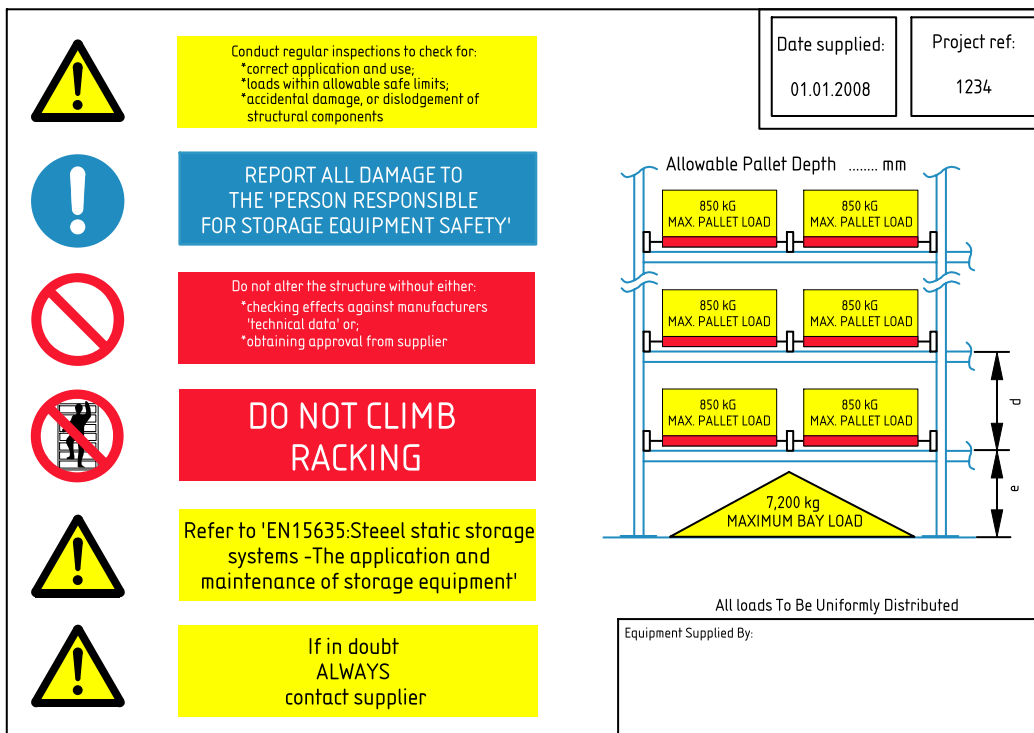

Key

- d beam pitch
- e height to first beam



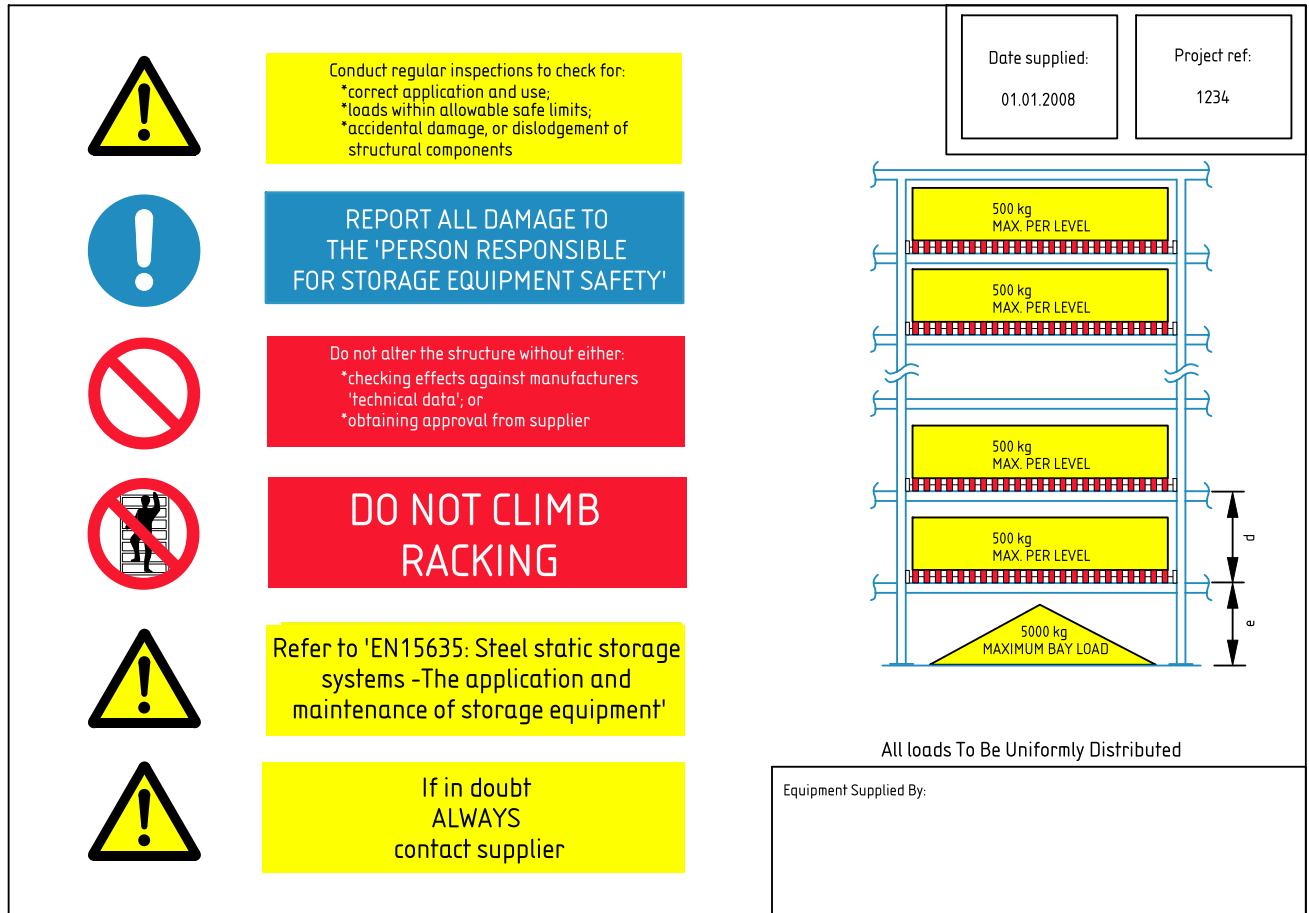
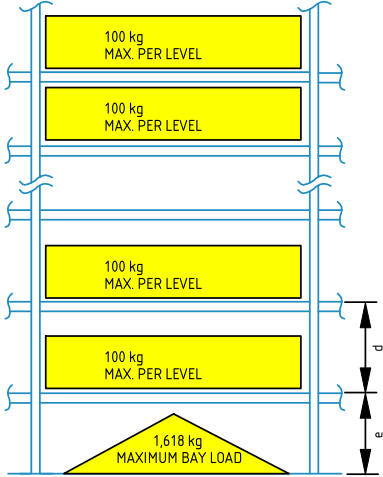



Figure B.7 — Example: Load warning notice for gravity live storage or push back systems in two lane per bay configuration



Key

- d beam pitch
- e height to first beam





Figure B.8 — Example: Load warning notice for carton live storage system

	<p>Conduct regular inspections to check for: *correct application and use; *loads within allowable safe limits; *accidental damage, or dislodgement of structural components</p>	<table border="1" style="width: 100%; border-collapse: collapse;"> <tr> <td style="width: 50%; padding: 5px;">Date supplied: 01.01.2008</td> <td style="width: 50%; padding: 5px;">Project ref: 1234</td> </tr> </table>	Date supplied: 01.01.2008	Project ref: 1234
Date supplied: 01.01.2008	Project ref: 1234			
	<p>REPORT ALL DAMAGE TO THE 'PERSON RESPONSIBLE FOR STORAGE EQUIPMENT SAFETY'</p>			
	<p>Do not alter the structure without either: *checking effects against manufacturers 'technical data' or; *obtaining approval from supplier</p>			
	<p>DO NOT CLIMB SHELVING</p>			
	<p>Refer to 'EN15635: Static steel storage systems -The application and maintenance of storage equipment'</p>			
	<p>If in doubt ALWAYS contact supplier</p>	<p>All loads To Be Uniformly Distributed</p> <table border="1" style="width: 100%; border-collapse: collapse;"> <tr> <td style="padding: 5px;">Equipment Supplied By:</td> </tr> </table>	Equipment Supplied By:	
Equipment Supplied By:				

Key

- d beam pitch
- e height to first beam

Figure B.9 — Example: Load warning notice for adjustable shelving system

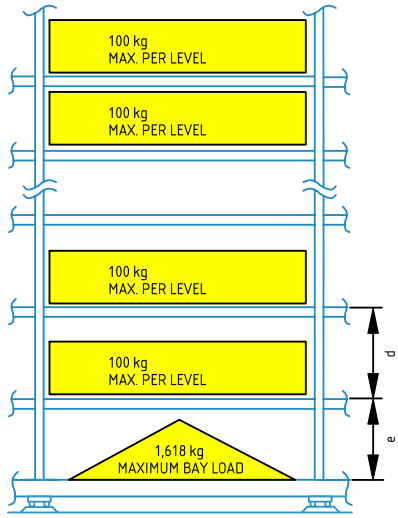
	Conduct regular inspections to check for: *correct application and use; *loads within allowable safe limits; *accidental damage, or dislodgement of structural components		REPORT ALL DAMAGE TO THE 'PERSON RESPONSIBLE FOR STORAGE EQUIPMENT SAFETY'		Do not alter the structure without either: *checking effects against manufacturers 'technical data' or; *obtaining approval from supplier		DO NOT CLIMB SHELVING		If in doubt ALWAYS contact supplier	<table border="1" style="width: 100%; border-collapse: collapse;"> <tr> <td style="width: 50%; padding: 5px;">Date supplied: 01.01.2008</td> <td style="width: 50%; padding: 5px;">Project ref: 1234</td> </tr> </table>	Date supplied: 01.01.2008	Project ref: 1234
Date supplied: 01.01.2008	Project ref: 1234											
												
All loads To Be Uniformly Distributed												
Equipment Supplied By:												

Key

- d beam pitch
- e height to first beam

Figure B.10 — Example: Load warning notice for mobile shelving system

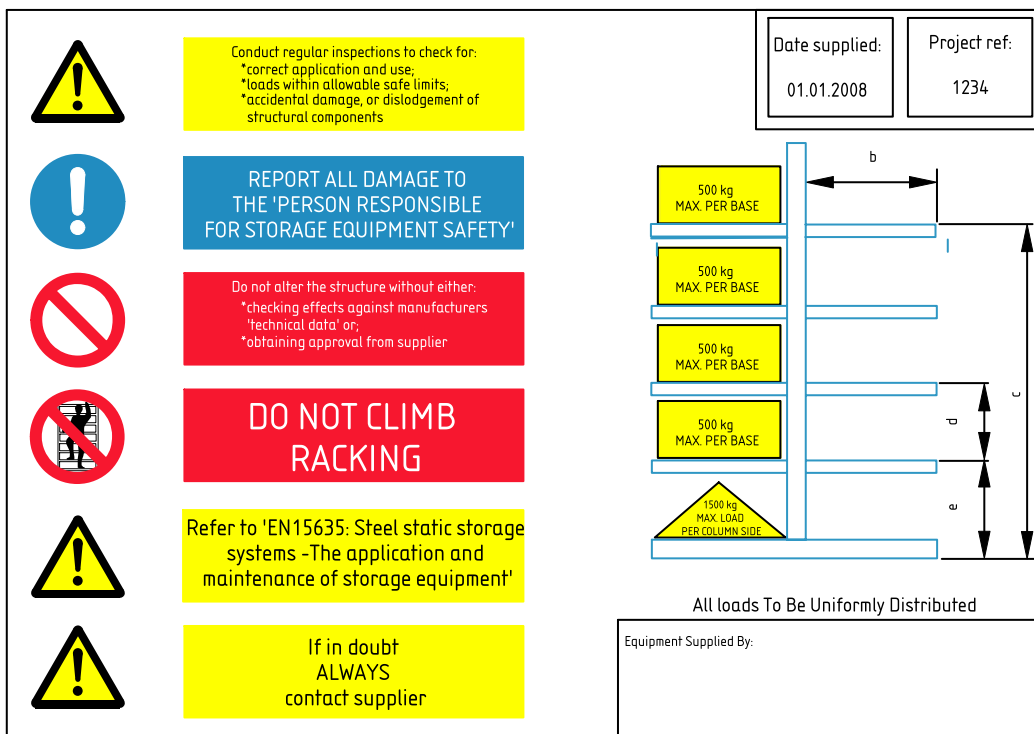

Key

- b arm length
- c maximum height to top arm
- d arm pitch
- e height to first arm

Figure B.11 — Example: Load warning notice for cantilever racking system





    	<p>Conduct regular inspections to check for: *correct application and use; *loads within allowable safe limits; *accidental damage, or dislodgement of structural components</p>	<table border="1"> <tr> <td>Date supplied: 01.01.2008</td> <td>Project ref: 1234</td> </tr> </table>	Date supplied: 01.01.2008	Project ref: 1234															
	Date supplied: 01.01.2008	Project ref: 1234																	
	<p>REPORT ALL DAMAGE TO THE 'PERSON RESPONSIBLE FOR STORAGE EQUIPMENT SAFETY'</p>	 <p style="text-align: right;">STRUCTURAL FLOOR</p>																	
	<p>Do not alter the structure without either: *checking effects against manufacturers 'technical data' or; *obtaining approval from supplier</p>																		
	<p>Refer to 'EN15635:Steel static storage equipment -The application and maintenance of storage equipment'</p>	<table border="1"> <tr> <th colspan="2">INDUSTRIAL TRUCK TYPE ALLOWABLE ON FLOOR</th> </tr> <tr> <td>Manufacturer:</td> <td>.....</td> </tr> <tr> <td>Model:</td> <td>.....</td> </tr> <tr> <td>Type:</td> <td>.....</td> </tr> <tr> <td>Single/Tandem Wheels Allowable</td> <td>.....</td> </tr> <tr> <td>Max Speed:</td> <td>.....</td> </tr> <tr> <td>Carrying Capacity:</td> <td>.....</td> </tr> <tr> <td>Fork Length:</td> <td>.....</td> </tr> <tr> <td>Axel Load:</td> <td>Operator Side:kg Fork Side:kg</td> </tr> </table>	INDUSTRIAL TRUCK TYPE ALLOWABLE ON FLOOR		Manufacturer:	Model:	Type:	Single/Tandem Wheels Allowable	Max Speed:	Carrying Capacity:	Fork Length:	Axel Load:
INDUSTRIAL TRUCK TYPE ALLOWABLE ON FLOOR																			
Manufacturer:																		
Model:																		
Type:																		
Single/Tandem Wheels Allowable																		
Max Speed:																		
Carrying Capacity:																		
Fork Length:																		
Axel Load:	Operator Side:kg Fork Side:kg																		
<p>If in doubt ALWAYS contact supplier</p>	<p style="text-align: center;">All loads To Be Uniformly Distributed</p> <p>Equipment Supplied By:</p>																		

Figure B.12 — Example: Load warning notice for mezzanine floor system



Key

- a pallet width
- b load width
- d guardrail pitch
- e height to first guardrail

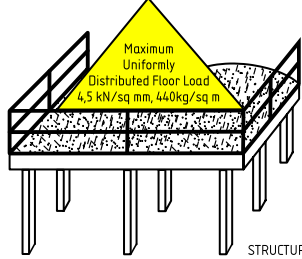
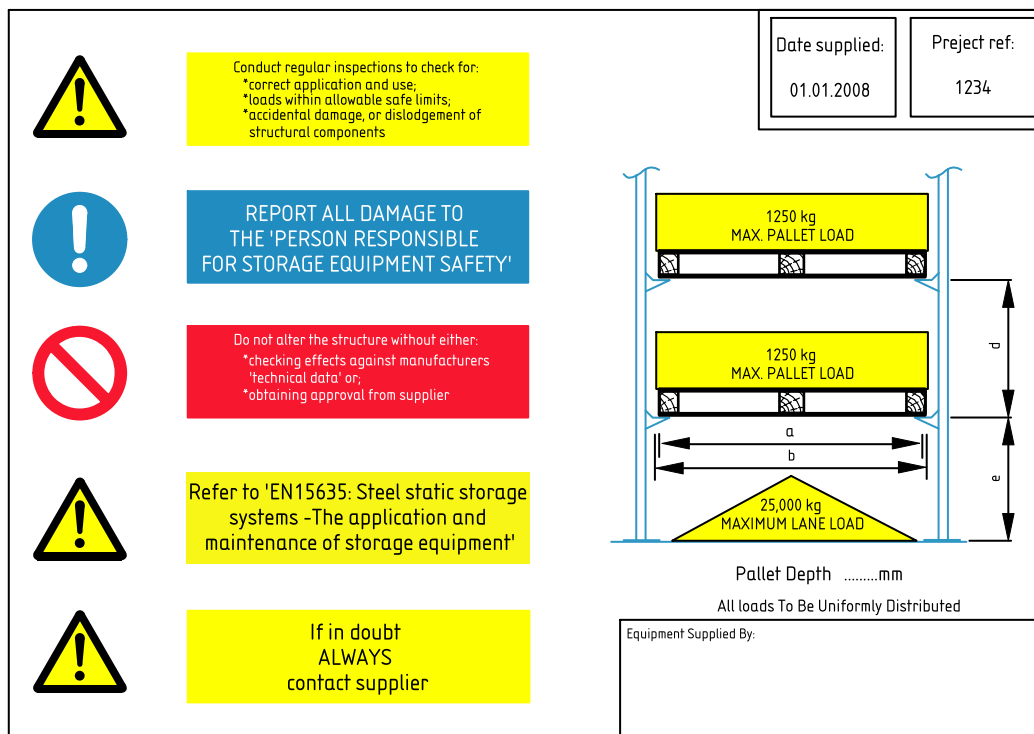
Figure B.13 — Example - Load warning notice for drive-in racking systems

Annex C (informative)

Pallet damage

Damage or defects which make a pallet unacceptable for use in pallet racking are given in Figure C.1

NOTE See EN ISO 18613

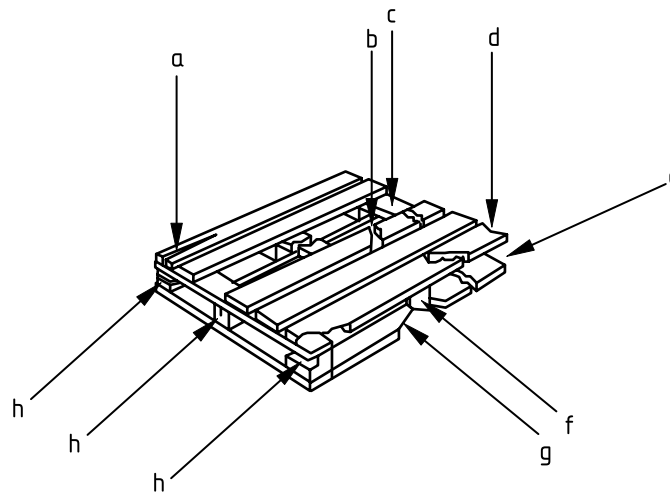

Key

- a splits on boards of more than half of the width or the length of the board
- b broken board
- c missing board
- d missing wood on a board of more than a third of the width of the board
- e missing block
- f block turned more than 30°
- g missing wood on a board between two blocks of more than a quarter of the width of the board or if nails are visible,
- h missing wood or splits on a block of more than half of the width or height of the block

Figure C.1 — Illustration of pallet damage to a perimeter base pallet making its re-use unacceptable

In addition the pallet cannot be re-used if:

- a) nail heads or nail points are protruding from the boards;
- b) inadequate components have been used (boards or blocks too thin, too narrow, too short);
- c) general condition is so poor that the load-bearing capacity cannot be ensured (rotten boards or several splits in boards or blocks) or the merchandise is at risk of being dirtied.

A skid pallet cannot be re-used if:

- i) boards are missing or broken;
- ii) wood is missing on lead boards to such an extent that on one board two or more nail shanks are visible or, on more than two boards, one or more nail shanks are visible;
- iii) blocks are missing, broken or split to such an extent that more than one nail shank is visible;

- iv) essential markings are missing or illegible;
- v) inadequate components appear to have been used (boards or blocks too thin, too narrow, or too short);
- vi) the general condition is so poor that the load-bearing capacity cannot be ensured (rotten boards or several splits in boards or blocks), or the merchandise is at risk of being dirtied.

The guidance given above for perimeter base and skid pallets may be used as a general guide for examining other types of wooden pallets such as euro-pallets marked with the (EUR) stamp.

NOTE The European Pallet Association (EPAL) and the International Union of Railways (UIC) offer advice and supply technical codes of practice for the examination and use of their (EUR) pool pallets.

Annex D (informative)

Safety of storage equipment in use and evaluation of damaged components

D.1 Reduction in margin of safety of damaged racking uprights or bracing members

Almost all damage to storage equipment carrying unit loads is inflicted by the mechanical handling equipment moving in or around the storage installation.

Any damage will reduce the ultimate load carrying capacity of a rack to some degree thereby eroding the manufacturer's design safety factors. Users should be aware of this situation and understand the need to monitor the racking carefully to ensure that all damage is identified and dealt with promptly and appropriately.

Clause 9 contains practical advice based on many years of experience on the use of this APR storage equipment. The action levels provide a reasonable balance between safety and practicality in use and are based on extensive use and experience within the industry. It is not possible however, in the present state of knowledge, to predict exactly the effects of specific damage on ultimate load carrying capacity. Should any user wish to specify that in a particular set of circumstances the manufacturer's design safety factors are the minimum then no damage shall be allowed. Generally, however this document is believed to be an acceptable compromise between the need to provide a safe working environment and the acceptance of minor knocks and a small amount of damage that will occur in the best-regulated situations.

The damage evaluation rules can seem relatively severe when compared to the damage that is sometimes seen in warehouses in use.¹

Moderate damage can result in a substantial loss of load carrying capacity, (see Figures D.1 and D.2). From compression tests, it has been shown that the sketched damage results in a reduction in the load carrying capacity in the order of 30 % to 40 %.

The explanation of this phenomenon can be that there could be a number of positive aspects which will prevent a collapse, such as:

- a) steel strength properties of the rack components can be greater than the minimum values, guaranteed by the specified steel grade (e.g. by as much as 15 %);
- b) actual total of pallet loads present can be somewhat lower than the specified design value. This reduced loading can be substantial in some situations;
- c) tolerances of build and manufacture can be better than those specified giving another small benefit.

For an upright design that fulfils prEN 15512, this situation could perhaps result in 40 % reduction in load carrying capacity. This is after damage up to the GREEN LEVEL limit that has reduced the load carrying capacity.

The new reduced estimate of the load factor, (margin of safety) is, for example, calculated as follows:

¹ Recent research (Dutch Institute TNO Bouw, Report 96-Con-R1371 and Swedish Lund University, Report TVSM – 7122) has confirmed this approach to damage evaluation.

$(\text{reduced load capacity}) \times (\text{design load factor}) \times (\text{increased steel strength}) \div (\text{reduced actual imposed loading})$

Therefore, the reduced margin of safety = $(1,0 - 0,4) \times 1,4 \times 1,15 \div 0,80 = 1,21$.

This value of 1,21 is lower than the basic design value of $(\text{load factor}) \times (\text{material factor}) = 1,4 \times 1,0 = 1,4$ but will not result in an immediate collapse. However, the same damage picture will result in an actual safety margin of about: $(1,0 - 0,4) \times 1,4 = 0,84$ if these positive influences are coincidentally not present.

Because 0,84 is smaller than 1,0 there will be a danger of collapse with serious implications for health, product and productivity.

The user should be responsible for ensuring damage is monitored and for taking immediate appropriate action. A damage level as indicated in Figures D.1 and D.2 is unsafe and should result in the load being immediately removed from the racking components in question.

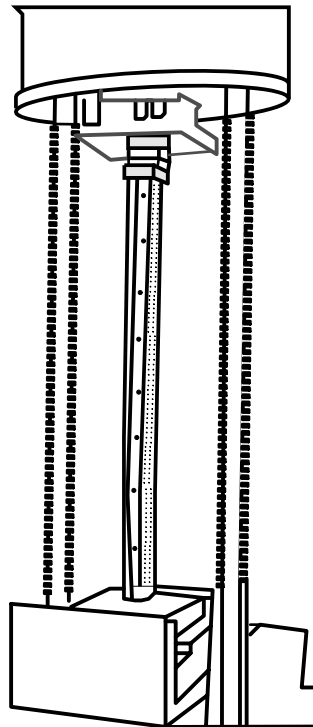

Figure D.1 — Damage of the magnitude shown resulted in a reduction of load carrying capacity under compression test in the order of 30–40 %

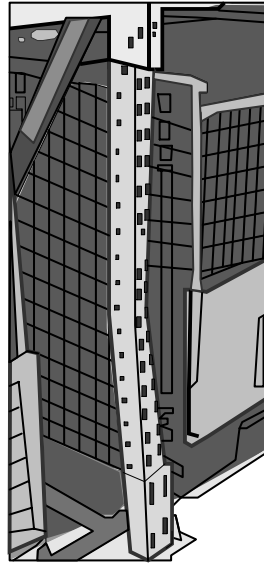

Figure D.2 — Upright damage at approximately 1000 mm above ground level from a rack in which a major collapse had taken place

D.2 Storage equipment inspections

D.2.1 General

A regular schedule of storage equipment inspections is essential and should be carried out to highlight safety problems caused by impact damage. These inspections should be thorough considering the practicalities of the warehouse operation concerned, which can preclude examination of rear beams and uprights and also other components concealed by pallet or shelf loads or at higher levels.

The inspections should be carried out by competent in-house staff, external specialists or the manufacturer's technical staff. In each case, however, the examination should be formal with a written report documenting the extent and results of the examinations. These reports should be reviewed at least annually to generate feedback on improving operating procedures to minimize damage and improve safety.

Inspectors carrying out high-level inspections will require access equipment including appropriate safety equipment. Under no circumstances should inspections be carried out by riding, or being lifted, on the truck forks.

An ongoing training programme for in-house racking inspectors/persons responsible for safety should be considered ensuring an adequate supply of competent persons.

Safety barriers and free standing upright protection should be provided at end uprights located at the intersections of aisles and gangways. Other uprights can also be protected; however, care needs to be taken that adequate clearances exist to ensure the satisfactory operation of all aisle equipment. Upright protection can reduce the effects of an accidental collision and can prevent serious upright damage. Upright protectors are intended as sacrificial protection and will need to be replaced once they are damaged and ineffective.

Inspection of load and information notices should take place. Sufficient notices should be attached to all racking installations to enable fork lift truck operators to see the safe maximum working loads that are the basis of the installation design. Inspectors should be specifically instructed to check and confirm that these notices are present and more importantly are up to date and relevant to the installation. All unauthorized and unapproved modifications should result in a RED RISK category until corrective work is carried out.

New load warning notices for authorized modifications are available from the original racking equipment manufacturer. New load warning notices should be installed at the time of equipment modification.

D.2.2 Inspection schedules

D.2.2.1 General

The frequency and severity of damage to storage equipment is influenced by factors such as:

- a) throughput of the stored goods;
- b) skill of the fork lift truck drivers;
- c) extent and possibility of providing upright protection;
- d) adequacy of the operating clearances.

As a guide, a user should commence by inspecting at intervals as stated in 9.4.2 then increasing the time interval if confidence allows. The rate of usage, steady or intermittent, or throughput of the system will affect the frequency of inspections.

D.2.2.2 Minimizing damage re-occurrence

The chance of an accidental collision damaging and weakening the storage equipment can be minimized by reducing or eliminating the possibility of damage re-occurring. This can be supported by good practice, such as:

- a) good installation layout design;
- b) good management;
- c) good housekeeping;
- d) good MHE operator training;
- e) good aisle markings;
- f) provision of upright protection.

D.2.3 Inspection for overloading of beams, cantilevers or shelves

D.2.3.1 General

Pairs of beams, cantilevers or individual shelves or shelf panels can be accidentally subjected to loads in excess of their specified design load. Overloading may produce a sag in these members, which is permanent.

D.2.3.2 Beam deflection requirement for APR systems

All structures and parts of structures will deform to varying degrees under load. Elastic deformations increase as the load increases and recover completely when all the load is removed.

The deflection requirement for beams is based on the clear span L . The requirement is for the deflection not to exceed the span dimension divided by 200 or another specified ratio.

Thus for span $L/200$, with a span $L = 2\ 700$ mm a deflection limit (δ) = 13,5 mm would result.

D.2.3.3 Beam strength requirements for APR systems

As well as a deflection requirement, structural components should always satisfy a beam strength requirement. If strength governs the beam design then the beam will be overloaded before the deflection limit of span/200 is reached.

Example: if the beam load on a pair of beams is limited by the beam strength and not by deflection, then the deflection at the allowable working load will be less than $L/200$.

If the 2700 mm span beam in the above example had an allowable working load on a pair of beams of 2000 kg and the resulting deflection was 10 mm then the beams would be seriously overloaded by 35 % if the load was increased until the deflection reached the limitation of $\text{span}/200 = 13,5$ mm.

Annex E (informative)

Use of the storage equipment – Method of placement and orientation

E.1 General

Care should be taken in the placement and removal of load make up accessories so that no additional forces to those reflecting the likely result of good practice, or impact loads are applied to the racking by the pallet handling process. Fork lift truck drivers should have specific training where storage equipment is concerned because the design of a rack does not normally consider such large additional and avoidable forces such as drag or impact.

When carried out carefully no substantial horizontal or vertical placement loads will affect the racking. Side shift and tilt movements of the masts especially should be carried out properly.

The stiffness of the fork truck mast will affect the ability of the driver to operate accurately and without impacting the racking when placing load make up accessories at high levels. The heavier the unit load is in relation to the maximum load capacity of the truck, the greater this effect becomes.

The load-carrying capacity of storage equipment is also dependent on the correct location of the unit load. Where a rack compartment, shelf or cantilever arm has been designed for a distributed load then this should be maintained in practice. Figures E.1 and E.2 give examples of non-uniform loads that cause overloading. Similarly, some types of four-way entry pallets can have restrictions of use in certain applications.

It is important, therefore, to ensure that only the correct type of pallet is placed on the racking.

E.2 Placement and asymmetric loading

Asymmetric loading, as shown in Figure E.1, should not occur because of the difficulty in controlling the degree of overhang. Also, the operating aisle width is adversely affected. And not all storage equipment components will be equally loaded. This would be the case for asymmetrically placed loads or if more than two beams or cantilever arms carry the load.

In Figure E.1 the load F acts at the centre of gravity of the unit load.

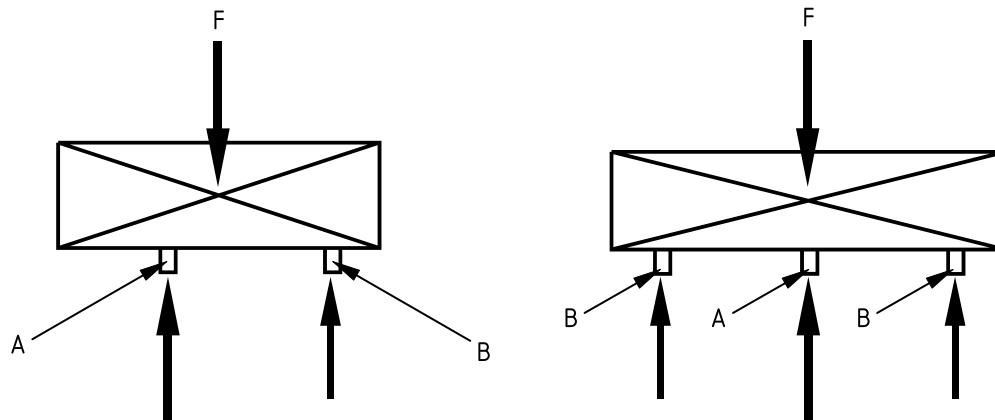

Key

- F weight of Unit load
- A heavier loaded support beam
- B lighter loaded support beam

Figure E.1 — Asymmetrically placed unit load and unit load supported by three arms or beams

The load supported by the beam or arm at A is greater than the load supported by beam or arm at B. The load supported by the outer beams or arms A is not the same as the load supported by the central beam or arm B.

Beams or cantilever arms loaded such that support reactions at A and B are unequal is a situation that is potentially unsafe unless considered in design.

Flexible loads should be correctly stored in or on a purpose-designed medium for storage on beams or cantilever arms.

Figure E.2 shows a flexible load that is incapable of correct load distribution onto three beams or cantilever arms.

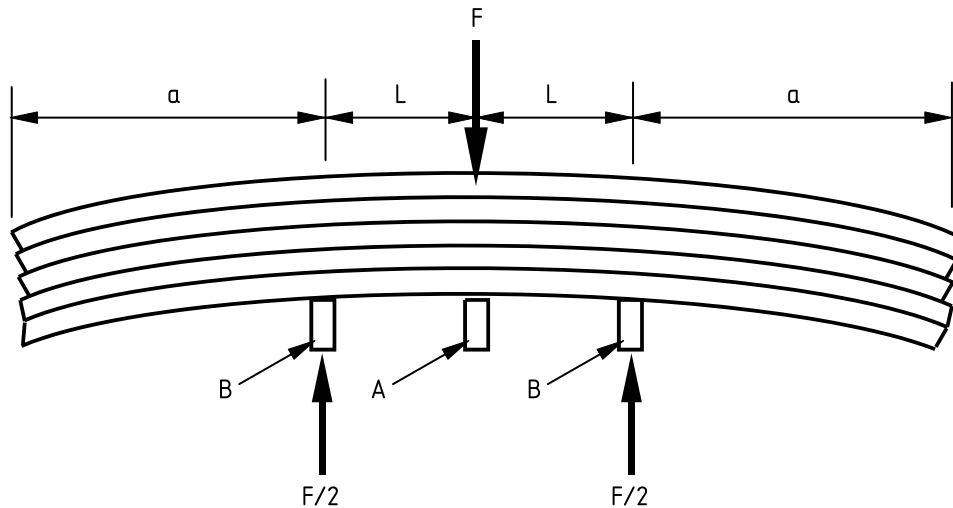

Key

- a equal overhang
- L equal beam or arm spacing
- F load
- A loaded support beam
- B support beam carrying no load

Figure E.2 — Example of the behaviour of a flexible unit load

E.3 Unevenly distributed loading on pallets or other media

Figure E.3 gives an example of point loaded beams despite the goods being palletised. All beams designed to carry such loads should be identified as such on the safe loading notices.

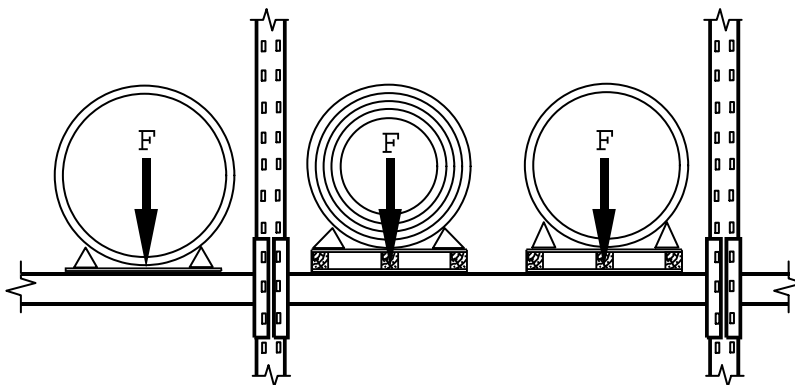

Key

- F Load

Figure E.3 — Beams carrying palletised non-distributed point loads,

Load make up accessories with unevenly distributed loading as shown in Figure E.1 to E.4 result in racking components such as beams, being unequally loaded which may be an unsafe situation.

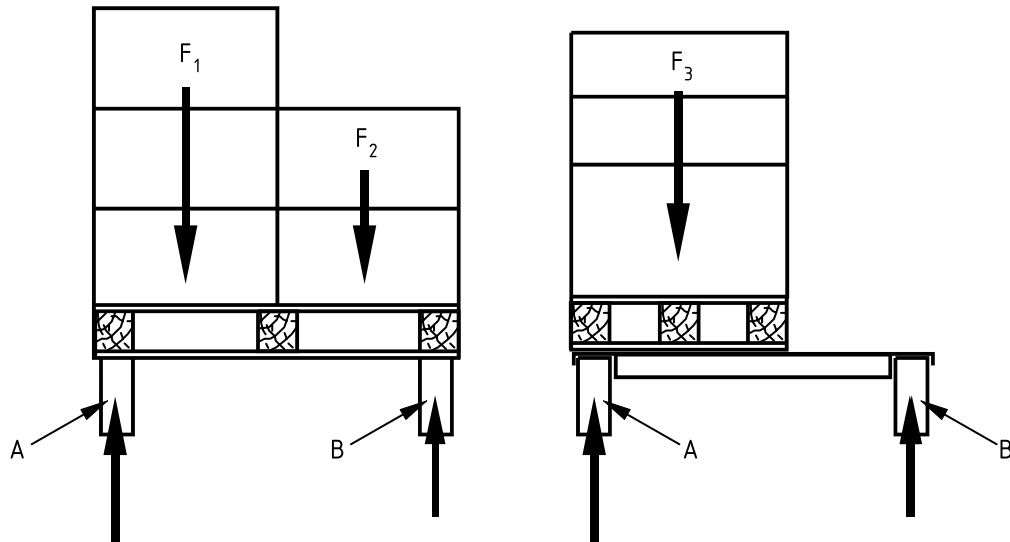

Key

- A heavier loaded support beam
- B lighter loaded support beam
- F_1 load
- F_2 load
- F_3 load

Figure E.4 — Examples of non-uniform pallet loading

E.4 Incorrect placement of unit loads

If a unit load is not placed in the correct way, a larger than normal horizontal and/or vertical force will be exerted on the storage equipment during loading.

For example, a larger than normal horizontal force will be exerted on the storage equipment during loading when either of the following types of misuse occurs:

- a) When a pallet, or other media, is pushed rearwards while in contact with the beams or pallet foot supports, thereby creating a large horizontal frictional force. For example, in the case of a steel stillage when the front two of the four legs are placed on the pallet foot supports and the stillage is slid into the storage position;
- b) When a backstop is intentionally and forcibly used, i.e. the truck driver continues driving until impact occurs with the pallet stop. In practice, this can occur when pallet backstops are provided, thereby creating large impact forces and damage to the backstops and supporting rack structure. Therefore, sufficient horizontal clearance should be provided according to EN 15620 and truck drivers should be trained to place the unit loads correctly and accurately without the use of pallet buffering back stops.

E.5 Correct and incorrect location of unit loads

With a maximum allowable compartment loading of two 1000kg pallets an example of good practice is shown in Figure E.5. The application of load as shown in Figure E.6 is not an overload condition although it should not occur with good operator training. Figure E.7 shows bad practice which results in a dangerous overloading situation.

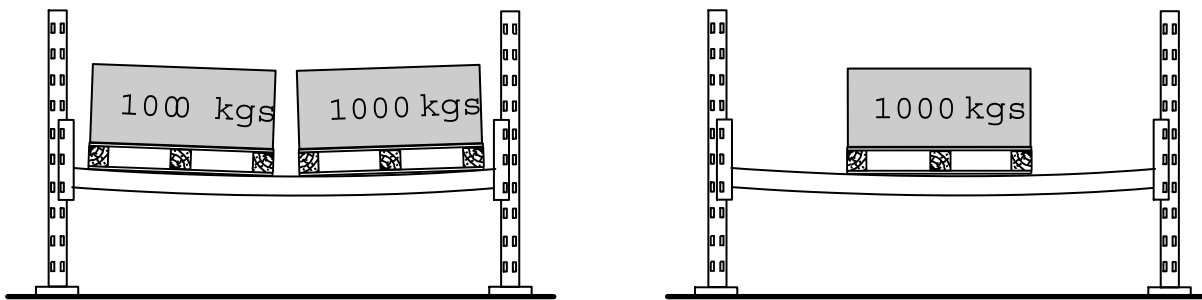

Figure E.5 — Correct two-pallet load distribution Figure E.6 — Incorrectly positioned unit load

For practical purposes the loading shown in Figure E.5 can be assumed to be a uniformly distributed load on a pair of beams where there is an equal front and back pallet and load over hang of the beams.

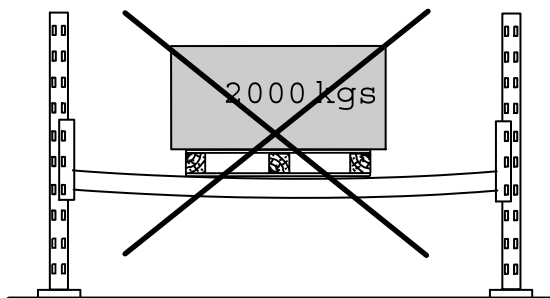

Figure E.7 — Dangerous overload condition

Bibliography

Further information to aid the user and the specifier can be found in the following publications²:

- [1] EN ISO 18613, Repair of flat wooden pallets (ISO 18613:2003)
- [2] FEM 10.2.05³, Safety in working with lift trucks in and around pallet racking
- [3] FEM 10.2.06, The design of hand loaded static steel shelving systems
- [4] FEM 10.2.07, The design of drive-in and drive-through pallet racking
- [5] FEM 10.2.08, The seismic design of static steel pallet racking
- [6] FEM 9.831, Rules for the design of storage and retrieval machines - Tolerances, deformations and clearances in the high-bay warehouse
- [7] European Commission code 92/58/EG Safety colours 1992
- [8] European Council Directive 92/59/EEC to standardise safety signs
- [9] EN 528, Rail dependent storage and retrieval equipment — Safety
- [10] EN 1998 (all parts), Eurocode 8: Design of structures for earthquake resistance
- [11] EN 1993-1-1, Eurocode 3: Design of steel structures - Part 1-1: General rules and rules for buildings
- [12] EN 1993-1-3, Eurocode 3 - Design of steel structures - Part 1-3: General rules - Supplementary rules for cold-formed members and sheeting
- [13] prEN 15512, Steel static storage systems — Adjustable pallet racking systems — Principles for structural design

² All FEM documents mentioned in this document may be purchased online from Fachverband Foerdertechnik in the VDMA at the following address: <http://fem.vdma-verlag.de/>

³ This document is in course of preparation and will be published in the future. It will be mainly of relevance to a user of adjustable pallet racking and drive-in racking.

BSI - British Standards Institution

BSI is the independent national body responsible for preparing British Standards. It presents the UK view on standards in Europe and at the international level. It is incorporated by Royal Charter.

Revisions

British Standards are updated by amendment or revision. Users of British Standards should make sure that they possess the latest amendments or editions.

It is the constant aim of BSI to improve the quality of our products and services. We would be grateful if anyone finding an inaccuracy or ambiguity while using this British Standard would inform the Secretary of the technical committee responsible, the identity of which can be found on the inside front cover. Tel: +44 (0)20 8996 9000. Fax: +44 (0)20 8996 7400.

BSI offers members an individual updating service called PLUS which ensures that subscribers automatically receive the latest editions of standards.

Buying standards

Orders for all BSI, international and foreign standards publications should be addressed to Customer Services. Tel: +44 (0)20 8996 9001. Fax: +44 (0)20 8996 7001 Email: orders@bsigroup.com You may also buy directly using a debit/credit card from the BSI Shop on the Website <http://www.bsigroup.com/shop>

In response to orders for international standards, it is BSI policy to supply the BSI implementation of those that have been published as British Standards, unless otherwise requested.

Information on standards

BSI provides a wide range of information on national, European and international standards through its Library and its Technical Help to Exporters Service. Various BSI electronic information services are also available which give details on all its products and services. Contact Information Centre. Tel: +44 (0)20 8996 7111 Fax: +44 (0)20 8996 7048 Email: info@bsigroup.com

Subscribing members of BSI are kept up to date with standards developments and receive substantial discounts on the purchase price of standards. For details of these and other benefits contact Membership Administration. Tel: +44 (0)20 8996 7002 Fax: +44 (0)20 8996 7001 Email: membership@bsigroup.com

Information regarding online access to British Standards via British Standards Online can be found at <http://www.bsigroup.com/BSOL>

Further information about BSI is available on the BSI website at <http://www.bsigroup.com>.

Copyright

Copyright subsists in all BSI publications. BSI also holds the copyright, in the UK, of the publications of the international standardization bodies. Except as permitted under the Copyright, Designs and Patents Act 1988 no extract may be reproduced, stored in a retrieval system or transmitted in any form or by any means – electronic, photocopying, recording or otherwise – without prior written permission from BSI.

This does not preclude the free use, in the course of implementing the standard, of necessary details such as symbols, and size, type or grade designations. If these details are to be used for any other purpose than implementation then the prior written permission of BSI must be obtained.

Details and advice can be obtained from the Copyright and Licensing Manager. Tel: +44 (0)20 8996 7070 Email: copyright@bsigroup.com