

Steel static storage systems — Specification of storage equipment

ICS 53.080

National foreword

This British Standard is the UK implementation of EN 15629:2008.

The UK participation in its preparation was entrusted to Technical Committee MHE/8, Steel shelving, bins and lockers.

A list of organizations represented on this committee can be obtained on request to its secretary.

This publication does not purport to include all the necessary provisions of a contract. Users are responsible for its correct application.

Compliance with a British Standard cannot confer immunity from legal obligations.

This British Standard was published under the authority of the Standards Policy and Strategy Committee on 31 January 2009

© BSI 2009

ISBN 978 0 580 57755 0

Amendments/corrigenda issued since publication

Date	Comments

EUROPEAN STANDARD

EN 15629

NORME EUROPÉENNE

EUROPÄISCHE NORM

November 2008

ICS 53.080

English Version

Steel static storage systems - Specification of storage equipment

Systèmes de stockage en acier - Spécification du système de stockage

Ortsfeste Regalsysteme aus Stahl - Spezifikation von Lagereinrichtungen

This European Standard was approved by CEN on 5 October 2008.

CEN members are bound to comply with the CEN/CENELEC Internal Regulations which stipulate the conditions for giving this European Standard the status of a national standard without any alteration. Up-to-date lists and bibliographical references concerning such national standards may be obtained on application to the CEN Management Centre or to any CEN member.

This European Standard exists in three official versions (English, French, German). A version in any other language made by translation under the responsibility of a CEN member into its own language and notified to the CEN Management Centre has the same status as the official versions.

CEN members are the national standards bodies of Austria, Belgium, Bulgaria, Cyprus, Czech Republic, Denmark, Estonia, Finland, France, Germany, Greece, Hungary, Iceland, Ireland, Italy, Latvia, Lithuania, Luxembourg, Malta, Netherlands, Norway, Poland, Portugal, Romania, Slovakia, Slovenia, Spain, Sweden, Switzerland and United Kingdom.



EUROPEAN COMMITTEE FOR STANDARDIZATION
COMITÉ EUROPÉEN DE NORMALISATION
EUROPÄISCHES KOMITEE FÜR NORMUNG

Management Centre: rue de Stassart, 36 B-1050 Brussels

Contents

Page

Foreword.....	4
0 Introduction	5
1 Scope	7
2 Normative references	7
3 Terms and definitions	7
4 Specification data of relevance to the supplier	11
4.1 Storage equipment planning	11
4.2 Storage system structural design	11
4.3 Storage equipment dimensioning	11
4.4 Storage equipment installation	11
5 Specification data of relevance to the user	12
6 Specific information to enable the project to be designed	12
6.1 General.....	12
6.2 Floor of the building	13
6.2.1 Floor specification	13
6.2.2 Information for the base plate and anchorage design.....	16
6.2.3 External floors.....	17
6.3 Rack-supported floors and mezzanines.....	17
6.4 Provision of edge guarding	19
6.5 Details of goods to be stored	19
6.5.1 Non-palletized goods	19
6.5.2 Palletized goods.....	19
6.5.3 Special loading accessories, e.g. box pallets, steel bins, skid pallets, roll containers, etc.....	20
6.5.4 Hazardous goods.....	20
6.6 Storage equipment design loads	20
6.6.1 General.....	20
6.6.2 Special considerations for mechanical loading	20
6.6.3 Method of operation	21
6.6.4 Impact provision requirements	21
6.6.5 Back stop specification.....	21
6.6.6 Pallet-buffering back stops.....	21
6.6.7 Pallet safety back stops	22
6.6.8 P&D stations.....	22
6.6.9 Imposed loads from handling equipment	22
6.6.10 Hand-loaded systems.....	22
6.7 Unit loads.....	22
6.7.1 Weight of unit loads.....	22
6.7.2 Overall dimensions.....	23
6.8 Non-uniform loads	23
6.9 Seismic, wind and snow loads	27
6.10 Environment.....	27
7 Support by, or very close to, another structure	28
8 Storage system configuration	28
8.1 Building plans	28
8.2 Precautions to reduce risk to personnel due to goods falling from racking or floors.....	29
8.3 Operational clearances	29
8.3.1 General.....	29

8.3.2	Racking classifications for pallet racking.....	30
8.3.3	Horizontal and vertical clearances for pallet racking	30
8.3.4	Aisle width dimensions.....	30
8.4	Drive-in racking	30
8.4.1	Clearances relating to the placement of pallets.....	30
8.4.2	Pallet specification	30
8.5	Passageways for pedestrians	30
8.6	Passageways for trucks under or through the racking structure	30
8.7	Means of escape.....	31
8.8	Free-standing upright protectors	31
9	Safety colours.....	31
10	Fire safety.....	31
11	Storage equipment inspections.....	32
Annex A (informative) Specifiers' and users' responsibilities		33
Annex B (informative) Suppliers' responsibilities		34
Bibliography.....		35

Foreword

This document (EN 15629:2008) has been prepared by Technical Committee CEN/TC 344 "Steel static storage systems", the secretariat of which is held by UNI.

This European Standard shall be given the status of a national standard, either by publication of an identical text or by endorsement, at the latest by May 2009, and conflicting national standards shall be withdrawn at the latest by May 2009.

Attention is drawn to the possibility that some of the elements of this document may be the subject of patent rights. CEN [and/or CENELEC] shall not be held responsible for identifying any or all such patent rights.

According to the CEN/CENELEC Internal Regulations, the national standards organizations of the following countries are bound to implement this European Standard: Austria, Belgium, Bulgaria, Cyprus, Czech Republic, Denmark, Estonia, Finland, France, Germany, Greece, Hungary, Iceland, Ireland, Italy, Latvia, Lithuania, Luxembourg, Malta, Netherlands, Norway, Poland, Portugal, Romania, Slovakia, Slovenia, Spain, Sweden, Switzerland and the United Kingdom.

0 Introduction

0.1 Racking and Shelving as work equipment

When specifying the design requirements for racking and shelving, there should be an awareness of national legislation regarding work equipment. This legislation is based upon the European Directives:

- a) 89/391/EEC: "Concerning measurements to promote the improvement of safety and health for the use of work equipment by workers at work";
- b) 89/655/EEC: "Concerning the minimum safety and health requirements for the use of work equipment by workers at work"

This European Standard should be considered in conjunction with the application and maintenance of storage equipment (See EN 15635).

0.2 Structural Eurocodes for load bearing structures and buildings

The determination of the safe load bearing capacity of racking and shelving is a structural engineering task and therefore the Eurocodes are relevant, particularly EN 1993-1-1 and EN 1993-1-3, for the design. The codes and guidelines worked out by CEN/TC 344 are intended to amplify and clarify the requirements of the Eurocodes, since they particularly apply to design, while specification, installation, application and maintenance are considered as special requirements for racking and shelving products. This European Standard covers specification.

0.3 Additional European standards for racking and shelving

Due to the differences in the shape of structural components, detailing and connection types, additional technical information to the Eurocodes is required in order to provide state of the art guidance. This guidance is for the client or the consultant specifying the requirement, the practising engineer involved in the design, the installer building the structure and the user who maintains the structure in a sound condition suitable for safe use throughout its working life.

This, together with the need to provide harmonized design rules, is the reason why the European Racking Federation (ERF) has taken the initiative with the CEN/TC 344. This Technical Committee is preparing a number of European standards for specific types of racking and shelving used in specific applications as follows:

prEN 15512, Steel static storage systems — Adjustable pallet racking systems — Principles for structural design

EN 15620, Steel static storage systems — Adjustable pallet racking — Tolerances, deformations and clearances

EN 15635, Steel static storage systems — The application and maintenance of storage equipment

In drafting these documents, a liaison with other CEN TC's has been carried out as appropriate.

0.4 Additional information specific to this document

CEN/TC 344 documents may be useful for design cases not covered by the Eurocodes (other structures, other actions, other materials) and to serve as a reference document for other CEN TC's concerning design matters.

This European standard is applicable to:

- a) specifiers of storage equipment;
- b) committees drafting design-related product, testing and execution standards;
- c) clients (e.g. for the formulation of their specific requirements);
- d) designers and constructors;
- e) relevant authorities.

As part of the specification process, reference to prEN 15512, EN 15620 and EN 15635 ensures that both the user and the designer are aware of the constraints in each other's area and allows an effective design to be produced.

1 Scope

This European Standard supplies guidelines for the technical specification to allow the design of racking and shelving in its various forms such as adjustable pallet racking (APR), crane serviced racking, drive-in racking (DIR), cantilever racking and shelving systems, including their various forms of construction, using manually operated and controlled mechanical handling systems. Some other forms of storage equipments are only partially covered and further consideration, beyond the scope of this document, may be required.

This European Standard gives guidance for the specifier of storage systems to coordinate suppliers of all equipment including individual responsibilities.

This European Standard does not cover storage equipments manufactured from materials other than steel (except for certain accessories) and equipment intended to be used for domestic storage purposes.

2 Normative references

The following referenced documents are indispensable for the application of this document. For dated references, only the edition cited applies. For undated references, the latest edition of the referenced document (including any amendments) applies.

prEN 15512, *Steel static storage systems — Adjustable pallet racking systems — Principles for structural design*

EN 15620, *Steel static storage systems — Adjustable pallet racking — Tolerances, deformations and clearances*

EN 15635, *Steel static storage systems — The application and maintenance of storage equipment*

3 Terms and definitions

For the purposes of this document, the following terms and definitions apply.

3.1

adjustable pallet racking

APR

steelwork structure consisting of frames and beams adjustable in height, specifically designed to support pallets and unit loads

3.2

bay load

total allowable weight of all the unit loads in a bay of racking not including any unit loads that may be stored on the floor of the bay

3.3

compartment load

load which can be loaded into one compartment of a racking or shelving structure from one side

3.4

counterbalanced forklift truck

rider-operated type of forklift truck that carries its load cantilevered forward of its front main wheel axle and is stabilized with a counter weight at the rear of the truck

NOTE This type of truck is a general-purpose truck and may be used in wide-aisle pallet racking systems.

3.5
design clearances

nominal dimension between items used in the design

NOTE These clearances enable input and output of the load to take place without contact of the load with any other loads or any part of the storage system structure other than normal contact when the load is placed on the beams or other members provided for its support in storage.

3.6
double-deep racking

racking in which pallets can be stored two deep from one aisle into the installation and accessed by a specially adapted long reach fork mechanism

3.7
drive-in racking
DIR

system of racking that provides blocks of storage where pallets are stored two or more deep and access is gained by driving a lift truck into a lane with pallets supported along their sides on beam rails supported from the uprights

3.8
drive-through racking

system of racking that provides blocks of storage where pallets are stored two or more deep similar to DIR except that the truck can be driven into a lane on one side of the block and out of the other if there are no obstructions

3.9
frame load

total allowable weight of all the unit loads transmitted to the frame by the members attached to the frame

3.10
hand pallet truck

small hand-operated truck used for moving pallets around on level floors and the pallet is lifted clear of the floor by raising and lowering a tiller bar that operates a hydraulic lifting device

3.11
intrusive stacking

placement or retrieval of a pallet where the turning radius or length of a lift truck is greater than the aisle width and part of the pallet storage location concerned is used by the truck forks and load when turning to place or retrieve a pallet

3.12
mechanical handling equipment
MHE

mechanical equipment used to transport the unit load to be stored

3.13
mezzanine floors
RSA

additional floor above the ground floor slab level used for storage which can be free standing or attached to the building structure

3.14
narrow-aisle racking

pallet racking arranged in a similar way to wide aisle racking but having aisles of a reduced width for use with more specialist types of lift truck

3.15

pallet

portable platform, with or without superstructure, for the assembly of a quantity of goods to form a unit load for handling and storage by mechanical appliances

3.16

pallet buffer back stop

buffering back stop, which is specified as an aid for use by forklift truck drivers to deposit a unit load in the correct position in the racking

3.17

pallet safety back stop

safety back stop to prevent accidental collision of a pallet or its load with other unit loads or equipment, when that load is placed in the storage compartment

type (a) safety device, which protects against unintentional load movement within the racking and prevents loads from protruding or from falling into an aisle or into an area accessible to people

type (b) backstop to prevent accidental damage, usually placed at the back of a storage compartment, to prevent the accidental collision of a pallet or its load with other equipment, such as sprinklers, when a load is placed in the storage compartment

3.18

pick up and deposit stations

P and D stations

storage locations at the end of an aisle used as an interface between different types of mechanical handling equipment

NOTE The P and D stations can be used as an interface between the unit load and handling equipment that is dedicated to the rack aisle (such as very narrow aisle (VNA) trucks or cranes) and the conveyors or free movement trucks which service the installation. The P and D stations can also be used to accurately fix the location of the unit load relative to the racking. This is often used by trucks or cranes having a fixed length of fork stroke and ensures accuracy in the X and Z directions when placing the unit load onto the racking beams.

3.19

powered hand pallet truck

small hand-operated truck used for moving pallets around on level floors where the power for lifting and moving the pallet loads is provided by a battery and electric motor.

3.20

reach truck

stacking lift truck with outriggers where the load can be repositioned by moving the mast or fork arm carriage

NOTE These trucks are generally used in narrow aisle racking because their overall length is less than a counterbalanced lift truck of the same lifting capacity.

3.21

shelving

hand-loaded supporting surfaces supported by upright frames

3.22

specified allowable unit load

unit load allowed in the storage equipment

3.23

specifier

person or company that provides the supplier with a specification based on the user's requirements

NOTE The specifier can be a consultant or other specialist, the end user or the equipment supplier acting as the specifier.

3.24

storage equipment

structure used to store the unit loads

3.25

straddle-type stacker trucks

manually or electrically operated pallet trucks with straddle legs

3.26

supplier

company that supplies the storage equipment

NOTE The company may be the original manufacturer or an intermediate company acting as a distributor.

3.27

total racking or shelving load

total allowable load supported by all the primary load supporting members

NOTE This may be the total load from beams or shelves in a defined area of racking or shelving.

3.28

unit load

weight of an individual stored item that can be placed or retrieved in one operation

3.29

user

company or person who manages and operates the installation on a daily basis and is responsible for the continuing safety of the installation

3.30

very narrow aisle racking

VNA racking

pallet racking arranged with aisles of a width to cater only for the truck and the unit load width plus an operational clearance where the truck cannot make 90° turns into the rack face for loading and off loading

3.31

very narrow aisle truck

VNA truck

rider operated fork lift truck which can work in aisles only slightly wider than the truck or the unit load carried and is fitted with a fork mechanism permitting access on either side of the aisle without turning the main body of the truck.

NOTE 1 VNA trucks are normally guided within the aisles. Because of the accuracy required in placing pallets into the racking, these trucks usually pick the pallet loads up from a specially designed P&D station at the entrance to each aisle.

NOTE 2 A VNA truck is sometimes known as a Turret Truck.

3.32

wide-aisle racking

pallet racking arranged to leave aisles of sufficient width to allow the forklift truck equipment to traverse the length of the aisle and to make 90° turns into the rack face for loading and off loading.

3.33

90° stacking

placement or retrieval of a pallet where the forklift truck makes a 90° turn to face the rack during the placement or retrieval process.

NOTE In making this turn no part of the truck or load intrudes into the racking.

4 Specification data of relevance to the supplier

4.1 Storage equipment planning

In order to determine a safe design of the storage equipment to be supplied for the load carrying capacity, the following information shall be provided as a minimum by the user to the specifier:

- a) details of the site and building in which it shall be housed, its environment, its exposure to wind, snow and seismic conditions;
- b) properties of the storage equipment foundation, the floor;
- c) details of the goods to be stored on the equipment including the specification of the load carrying accessory, e.g. pallet, box, bin, etc.;
- d) specification of the allowable loads for the storage equipment;
- e) throughput and anticipated configuration of the equipment. The specifier shall consider all operational factors in the evaluation of the risk in the operation (see EN 15620);

NOTE This is to allow sufficient design clearances to be provided for the safe depositing and retrieval of goods.

- f) specification of the handling equipment to be used, e.g. type of truck etc., in relation to the storage equipment (see EN 15620 for information on truck turning radius and effective aisle width requirements);
- g) specify if the user shall carry out the installation of the storage equipment;
- h) all known information about planned future changes to storage requirements;

The specifiers' and users' responsibilities are further clarified in Annex A.

4.2 Storage system structural design

The supplier, provided with the relevant specification information, shall design the storage equipment in accordance with the relevant European Standards or, if not available, industry codes of practice. The designer may assume that the clearances specified in relation to the material handling equipment intended for use with its operational specification, are such that accidental collision forces may be neglected in the structural design.

4.3 Storage equipment dimensioning

For adjustable pallet racking, EN 15620 shall be used in the design and layout to provide guidance on the relevant tolerances, deformations and clearances.

4.4 Storage equipment installation

If it is specified that the installation work is not to be undertaken by the supplier, then the supplier shall provide written assembly and installation instructions to their customers on the basis that the installers are experienced and competent for the work involved.

NOTE The correct assembly and installation of the storage equipment is of equal importance to the provision of a safe structural design. The persons carrying out the assembly and installation should be trained and experienced in the work to be done and should be properly supervised and controlled to ensure that the health and safety of all persons is safeguarded. The quality and accuracy of the installation work can have a significant effect on the performance and structural integrity of the storage equipment. The supplier's workforce should be trained to carry out this work efficiently and have the experience to do so safely.

5 Specification data of relevance to the user

The specifier shall ensure that the user is made aware of all the details of the contract specification provided to the supplier for the design of the installation. In order to maintain the continuing safe use of storage equipment, the user shall ensure the following information specified for its design, construction and operation is taken into account:

- a) design layout and configuration;
- b) lift truck make and type specified including characteristic of the lift truck (e.g. dimension, turning radii, etc., see EN 15620);
- c) adequacy of the floor of the building on which the equipment shall be erected. The floor is the foundation and supports the applied loads including the storage equipment and the MHE and receives the base plate floor fixings;
- d) avoidance of rapid cooling or heating in cold store that can cause differential expansion or contraction movement between the racking and the concrete floor. Raising or lowering of the store temperature shall be done in such a way that it will not cause harmful differential movements that adversely affect the storage equipment or its floor fixings;
- e) instructions for assembly and installation provided by the supplier are fully implemented if the user constructs the installation or if a contractor other than the supplier constructs the installation;
- f) allowable load carrying capacity information that shall be provided by the supplier;
- g) method of equipment operation shall accord with the design information supplied by the user to the specifier. The lift truck shall be in accordance with the operational conditions (e.g. throughput, safe depositing at height, and moving of VNA trucks at height). Unless otherwise specified, the storage equipment supplier may assume correct application and maintenance for the design and that there are no special impact forces arising from loading operations to be taken into account;
- h) pallet shall be suitable for storage on beams or beam rails. Damaged pallets shall not be used;
- i) continuing safety of the storage equipment is dependent upon regular inspection for damage and maintenance during the life of the equipment. Information on the frequency and level of inspections is detailed in EN 15635;
- j) continuing safety of the system is dependent upon regular maintenance of the handling equipment;
- k) continuing safety of the storage equipment is dependant on the original structural design configuration not being altered without any proposed changes being first approved by the supplier or other qualified engineers.

NOTE To ensure safe operation of trucks and to avoid unforeseen difficulties or loss of storage capacity, the warehouse should, ideally, be designed after the storage equipment configuration has been decided upon.

6 Specific information to enable the project to be designed

6.1 General

The use of the storage equipment in practice shall not be in conflict with the information supplied to the specifier by the user. The design of the storage equipment should not generally take place without information being supplied to the specifier by the user.

This document covers those aspects of the specification that shall be provided as a minimum for the structural design:

- a) size and weight of items to be stored;
- b) reasons for provision of the back stops, e.g. for accident prevention or for pallet positioning;
- c) design resistance forces and stiffness requirements for the pallet back stops;
- d) equivalent static support forces applied to rack supported guide rails or by other equipment supported by the storage equipment.

The suppliers' responsibilities are further clarified in Annex B.

NOTE In designing the layout and configuration of the storage facility, the specifier should be familiar with the various requirements for the safe and economic design of the storage equipment as follows:

- 1) upright widths available for the bay loads and beam spacing;
- 2) beam dimensions available for the loads and spans envisaged;
- 3) use of back or spine bracing;
- 4) differences in turning radii and overall dimensions between lift truck models;
- 5) spatial requirements for safe operation;
- 6) level of skill provided by the nominated equipment installers.

6.2 Floor of the building

6.2.1 Floor specification

6.2.1.1 Floor construction

The specifier shall be responsible for confirming the suitability of the intended floor or foundation and its performance characteristics for the loads being imposed upon it by the racking, shelving or mechanical handling equipment.

NOTE 1 Floor construction materials that are easily compressible, such as many bituminous compounds, can offer negligible support and should be given special consideration.

NOTE 2 Floors constructed from tiles or small prefabricated slabs, etc. usually have low load carrying capacity and can suffer from irregular settlement. Such floors should not be used where heavy concentrated loads are imposed.

6.2.1.2 Floor loading

With a warehouse facility, the specifier shall confirm that the floor shall be suitable to support the imposed loads from the storage equipment and the MHE and shall be suitable for floor anchor fixings to be used.

NOTE 1 Floor fixings are installed by drilling holes in the floor slab and securing via mechanical, chemical or grouted anchors.

NOTE 2 The deformations of the floor, occurring as a consequence of the imposed loads, will cause the racking to be out of plumb. If the racking is no longer vertical, the gravity loads exerted by the contents of the racking will generate a horizontal sway load component, (see Figures 1 and 2). For a large unanticipated floor deformation, this horizontal component of load can be greater than the safe value considered in the design of the storage equipment.

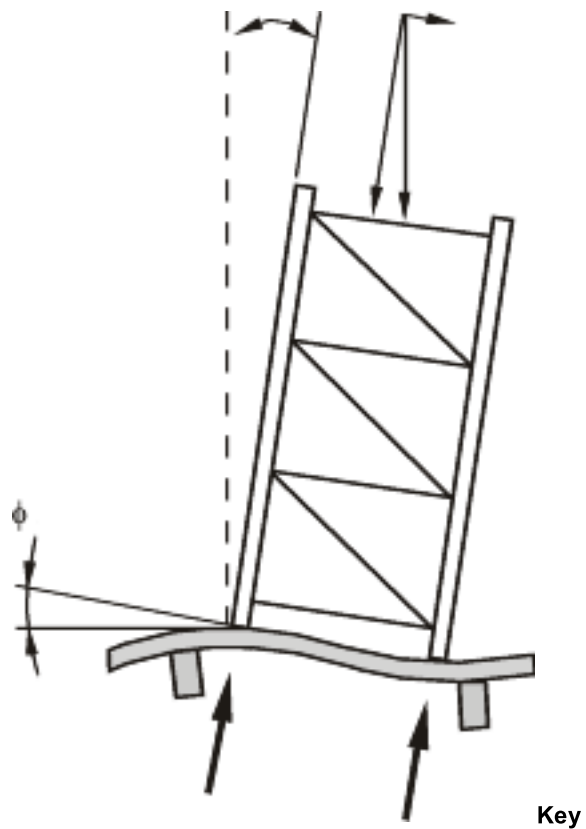

ϕ floor slope under the rack frame

Figure 1 — Tilt due to the suspended floor deformation resulting in additional bracing load and unequal column load effects

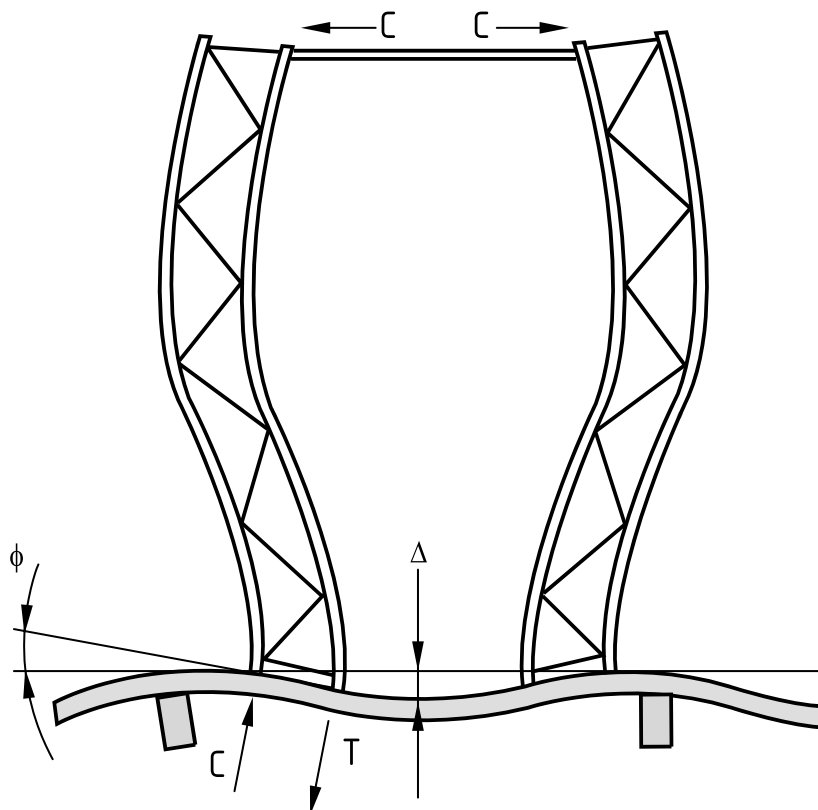

Key

- C compression
- T tension
- Δ floor deflection
- φ floor slope under the rack frame

Figure 2 — Additional horizontal and vertical forces on the storage equipment components such as portal ties, frame bracing, uprights and floor fixings due to suspended floor deformation

6.2.1.3 Floor deformations

The properties of the foundation base, including floor deformation over time, shall be defined by the specifier.

NOTE 1 Elastic floor deformation effects, such as those shown in Figures 1 and 2, can increase with time due to the creep of structural materials such as concrete, timber or unstable floor materials such as bitumen. Settlement of the subsoil under a concrete ground bearing floor slab or foundation base can also cause these effects.

NOTE 2 The storage equipment designer may consider the floor as quasi rigid (see EN 15620) unless otherwise specified.

NOTE 3 When VNA lift trucks are used, there is a relationship between the flatness, levelness, and deformation of the floor and safety and efficiency in use. For a given unevenness of the floor, the truck, which may elevate loads while travelling, will sway sideways in the aisle so as to risk colliding with the equipment or loads already placed.

6.2.1.4 Movement joints

The specifier shall define the extent of the potential movement across the movement joint. Special consideration shall be given to storage equipment floor fixings when they occur near to a joint and to the effects of joint movement on any storage equipment that may straddle such joints.

NOTE The purpose of movement joints in a concrete floor slab is to ensure that the stresses due to concrete shrinkage or to temperature changes concentrate the movement at clearly defined positions and do not fracture the slab randomly. Movement joints under racking uprights should be avoided within the rack area.

6.2.2 Information for the base plate and anchorage design

The specifier shall provide the supplier with comprehensive information regarding the floor for the design of base plates and fixings for the storage equipment.

Relevant information shall include the following.

- a) The concrete slab type:
 - 1) suspended or ground bearing;
 - 2) solid concrete or other type;
 - 3) with or without a top screed;
 - 4) thickness and grade of screed;
 - 5) thickness of structural slab;
 - 6) quality or grade of the structural slab concrete;
 - 7) use of additives, to the concrete during construction of a floor. These additives may cause metal parts such as base plates and floor fixings to corrode;
 - 8) size and location of any steel reinforcement relative to the slab surface;
 - 9) position and construction details of all expansion and movement joints;
 - 10) location of all cut out shrinkage joints which shall be treated as an edge of the concrete slab.

If no floor information is available, the equipment supplier may assume, for the purpose of design of the anchorage and base plate, that the floor is solid concrete, without a surface screed, and has a minimum strength of class C20/25.

- b) The floor materials, if the floor is not solid concrete, e.g. bituminous floors or concrete floors with bituminous surface screeds appropriate performance data shall be provided. If no information is available on the characteristics of a bituminous floor or screed, the equipment supplier may assume, for the purpose of design, that the allowable long term contact stress under a base plate has a design value of $0,3 \text{ N/mm}^2$ and is of a suitable thickness. Special consideration shall be given when anchoring to a bituminous floor or concrete floor with a bituminous surface screed.
- c) Deformations, flatness and variations in the horizontal level of the floor (for adjustable pallet racking refer to EN 15620).
- d) The presence of pre or post tensioning or other cables, ducts or under floor electric heater cables, it is very important for the personnel's safety and to prevent functional or structural damage to the floor to avoid any contact with these hidden dangers during drilling operations. The positions where drilling shall or shall not occur shall be clearly marked by the building owner or user.

NOTE Problems can occur if the floor contains hidden cavities such as in hollow pot or pre-cast slab floors. Such floor types can also cause problems under the effects of concentrated upright loads.

6.2.3 External floors

Racking erected in an external environment is subject to additional loads such as wind and snow loads and these forces shall be considered for the design including the design of the connection fixings and the foundation. Special considerations shall be made for hard standing areas.

6.3 Rack-supported floors and mezzanines

The following additional information shall be provided by the specifier for floors that are supported by storage equipment, such as floors over racks or shelving¹ suspended walkways and mezzanines:

- a) intended use of the floor, e.g. for office, storage, walkway, etc.;
- b) maximum uniformly distributed load over the floor area not occupied by storage equipment;
- c) maximum local loads that can occur, e.g. at lift truck loading and/or unloading areas;
- d) maximum concentrated loads may be caused by wheeled traffic such as pallet trucks or trolleys or by shelving standing on the floor decking (see below) imposed on the floor or mezzanine;
- e) additional requirements such as anti-slip, wear and tear resistance, ceiling light reflection etc.;
- f) requirement imposed due to fire safety regulations.

The minimum loads specified in prEN 15512 should be used for the design.

NOTE 1 In some countries national regulations may specify other minimum values for these loads and may require specific approval.

NOTE 2 Figures 3, 4, 5 and 6 show different configurations of a racking or shelving supported mezzanine or a walkway floor.

NOTE 3 The concentrated loads imposed on the mezzanine floor decking can be relatively high and load spreaders may be required.

The floor structure shown in Figure 4 shall be designed for the point loads caused by the storage equipment on the upper tier.

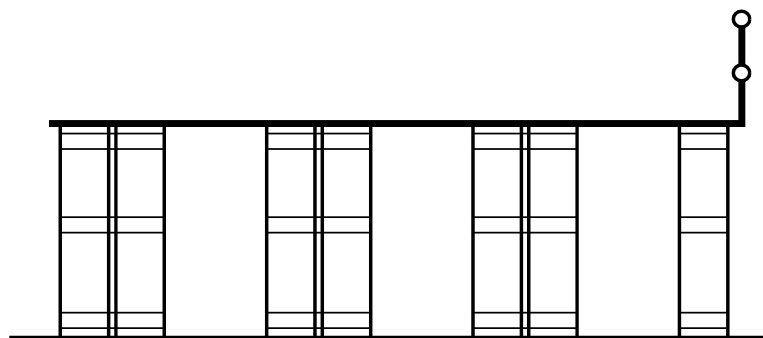

Figure 3 — Over-rack mezzanine floor

¹ Guidance on shelving design is available in FEM 10.2.06.

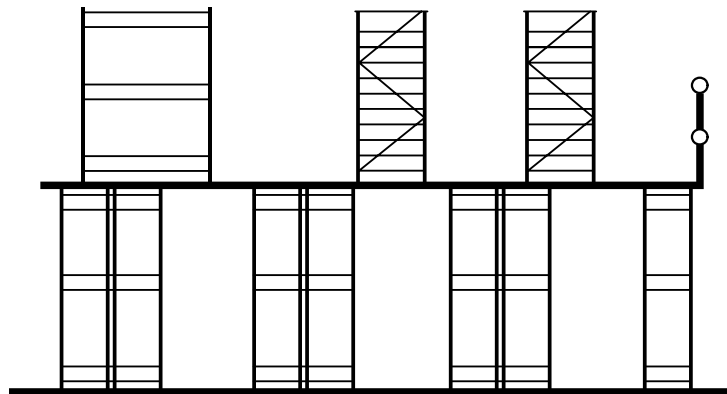

Figure 4 — Over-rack mezzanine floor supporting shelving

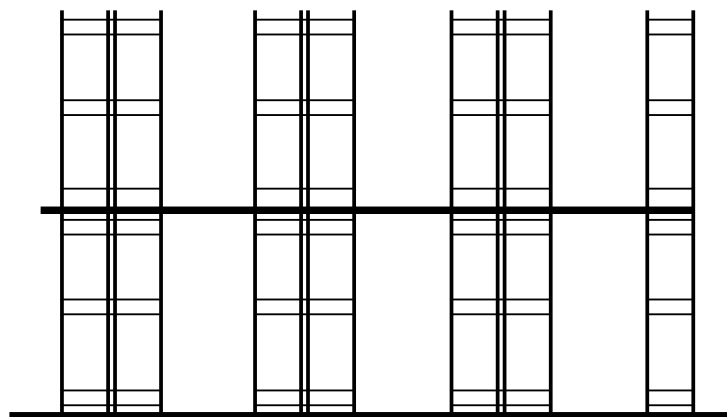

Figure 5 — Multi-tier shelf racking

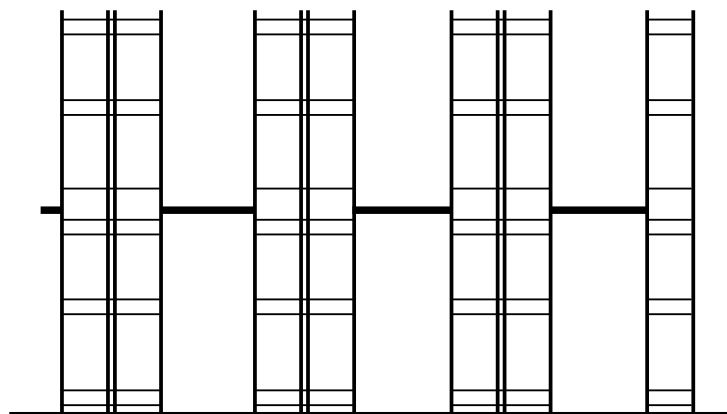

Figure 6 — Walkways suspended between the upright frames

The specification of the details and loading of all wheeled traffic on a floor shall be provided by the specifier to ensure a safe design. Details shall include the following:

- i) type and make of the wheeled load carrier plus the manufacturer's construction details;
- ii) if hand operated;
- iii) if powered, the acceleration, cornering and braking forces applied to the floor together with the maximum operational speed;
- iv) if a man-rider power-operated truck, the additional dynamic load effects; braking, accelerating, cornering, etc.;
- v) wheel diameters single or tandem, wheel base, spacing, etc.;
- vi) wheel material, steel, rubber, polyurethane, etc.;
- vii) distribution of the dead weight of the carrier to the wheels;
- viii) distribution of the maximum weight of the goods to the wheels.

6.4 Provision of edge guarding

The requirements of edge guarding in areas accessible to people may be controlled by national safety standards. Unless included in the project specification, edge guarding shall be provided for personnel safety only and shall not take into account the effect of impact from mechanical handling equipment.

Edge guarding shall be of adequate strength and stability to restrain a person liable to fall onto or against it.

NOTE 1 Areas where goods are raised or lowered by means of a lift truck are high risk areas. One method of edge guarding an opening at the edge of a floor can be to provide a special type of fence or barrier, which the worker can raise without having to approach the edge.

NOTE 2 Examples of edge guarding are handrails, knee rails, pallet gates, mesh screens and kickboards.

6.5 Details of goods to be stored

6.5.1 Non-palletized goods

Data to be provided in the specification shall include:

- a) length, width, height and shape per item;
- b) tolerances of unit load dimensions;
- c) weight per item;
- d) manner of handling.

6.5.2 Palletized goods

Data to be provided in the specification shall include:

- a) maximum weight of goods on one pallet;
- b) type and quality of pallet, pallet tolerances (actual minimum pallet dimensions) and pallet entry directions;

- c) maximum dimension of the unit load considering overhang, bulging and/or fanning out of goods, height of loaded pallet (see Figure 7).

6.5.3 Special loading accessories, e.g. box pallets, steel bins, skid pallets, roll containers, etc.

Data to be provided in the specification shall include:

- a) exact description of the loading accessory;
- b) maximum weight of goods in or on the loading accessory;
- c) dimensions;
- d) tolerances.

6.5.4 Hazardous goods

For the storage of hazardous goods the specifier shall define the additional requirements for the design of the storage equipment, if any.

6.6 Storage equipment design loads.

6.6.1 General

Data in the specification shall include, where applicable:

- a) maximum weight of the unit load;
- b) maximum uniformly distributed load per compartment;
- c) maximum loading per metre run or maximum weight plus dimension in the run direction of the uniform load, e.g. drive-in racking beam rails or dynamic storage racks;
- d) maximum load on a cantilever arm and the location of its centre of gravity;
- e) floor loading imposed on the storage equipment;
- f) flexibility of the load;
- g) if design loading is not uniform or is different from the above considerations, then all special and relevant details shall be provided.

6.6.2 Special considerations for mechanical loading

Special considerations in the specification, for mechanical loading, shall include:

- a) additional forces imposed on the storage equipment caused by the loading operation;
- b) types of fork lift trucks to be used;
- c) type of storage and retrieval equipment with a description of the loading imposed by the storage and retrieval equipment on the storage equipment if so supported.

6.6.3 Method of operation

The method of equipment operation shall be in accordance with the design information supplied by the user to the specifier. Unless specified otherwise the storage equipment supplier shall assume for the purposes of design that the requirements as defined in EN 15620 and EN 15635 are adhered to.

The method of handling goods shall be defined for establishing the loads imposed on the racking during placing operations.

NOTE 1 Good handling practice with mechanical handling equipment will not misuse or cause any impact loading to the storage equipment (see EN 15635). For crane storage and retrieval machines see FEM 9.831.

NOTE 2 If a forklift truck does not place a pallet in a controlled manner, a larger than normal force will be exerted on the storage equipment during loading. Examples are:

a) when a pallet is pushed to the back over and is in contact slid into position thereby creating a large horizontal frictional force (e.g. in the case of a steel stillage when it is tilted forward or backward and two of the four legs are sliding on the pallet foot supports);

b) when a pallet safety back stop is used as a pallet buffer back stop;

c) when the truck mast exhibits excessive flexibility.

6.6.4 Impact provision requirements

The user shall be responsible for preventing racking components being exposed to damage or impact (see EN 15620 and rEN 15635).

If impact resistance is specified by the user, the collision protection and/or impact provisions shall be defined by the specifier. These impact provision requirements shall be based upon the operational features and mechanical handling equipment to be used in the specific application.

6.6.5 Back stop specification

The specifier shall define the back stop design requirements by stating:

a) purpose of the stop, i.e. safety back stop or buffering back stop;

b) maximum allowable deflection of the end stop to protect ancillary equipment or to prevent a unit load from falling from its supports;

c) static equivalent horizontal design force of the dynamic impact force;

d) positions at which the force will be applied.

6.6.6 Pallet-buffering back stops

The forces imposed by the mechanical handling equipment onto the back stop shall be specified by the specifier. If not then the designer shall use the forces specified in prEN 15512.

NOTE 1 The use of pallet buffering back stops should not be used as a means of positioning pallets because they encourage misuse in terms of much higher impact forces than the minimum as defined in prEN 15512.

NOTE 2 Pallet buffering back stops are most frequently found in conjunction with forklift truck operations and are specified as a systematic positioning aid.

NOTE 3 The requirement for any type of pallet back stop should be carefully considered and clearly specified considering the following points:

a) The actual value of the buffering force for the design can exceed 100 % of the maximum unit load and much larger horizontal loads due to impact forces need to be taken into account in designing the racking (see prEN 15512). Inclusion of such impact forces in the structural design process inevitably leads to a heavier and more expensive racking structure.

b) Misuse will inevitably result in accidents and structural damage.

c) The correct choice of clearances based on EN 15620 should result in an economic and safe use of the storage volume available without the necessity for back stops.

6.6.7 Pallet safety back stops

The forces imposed by the mechanical handling equipment on the back stop shall be specified by the specifier. If the forces are not specified, then the designer shall use the forces specified in prEN 15512.

Design clearances shall be specified by the specifier to ensure that the safety pallet stop will only be impacted accidentally.

If, in practice, the pallet safety back stop is used in a systematic way as a positioning aid then it shall be considered as a pallet buffering back stop and be subject to the requirements of 6.6.6.

NOTE 1 Safety pallet stops for incidental loads may be required in accordance with EN 528 or for other reasons and may be provided where sufficient design clearances are available in an installation. These back stops are most frequently found in automated storage/retrieval crane operations.

NOTE 2 This type of stop is intended as a safety device to prevent loads being unintentionally moved within the racking such that they protrude or fall into an aisle or an area accessible to people.

6.6.8 P&D stations

The design loads and positioning tolerances shall be clearly defined in the specification especially if the P&D station is to be subjected to pallet buffering forces when centring devices are used.

NOTE The design specification of P&D stations requires special consideration and attention to performance requirements since these items of storage equipment are frequently positioned at crucial points in the storage system and reliability is important. P&D stations can be used by cranes, trucks or other automated equipment such as conveyors or any combination of such storage handling equipment.

6.6.9 Imposed loads from handling equipment

In the case of cranes or rack-guided VNA trucks, the specifier shall define the static equivalent design forces for all the vertical and horizontal load handling, buffering or dynamic loads to guide or supporting rails to which the storage equipment may be subjected.

6.6.10 Hand-loaded systems

In a hand-loaded situation, where the unit load or package exceeds 10% of the total shelf design load, this shall be specified and the weight of the unit load shall be provided to enable the supplier to make a suitable allowance for impact.

6.7 Unit loads

6.7.1 Weight of unit loads

The specifier shall define the maximum weight of the unit load.

The specifier may define allowable loads for the upright frame and for overall stability (total storage system loads) loads that are up to 20% lower than those based upon the maximum unit load. This variation in

allowable loads for different aspects of design may only be used when a management system is used in the storage equipment to ensure that the lower allowable frame, and stability loads specified are never exceeded.

NOTE 1 The management system should include the distribution of the allowable loads over the racking height at each bay and down the length of the run.

NOTE 2 If reliable warehouse control software is available which can control the upright loading at individual pallet levels, then this may be taken into account in the specification of load distribution in the racking.

6.7.2 Overall dimensions

The physical proportions of the pallet and its load characteristics shall be provided by the specifier and form the basis of providing support and clearances, enabling the system to be operated safely (see Figure 7).

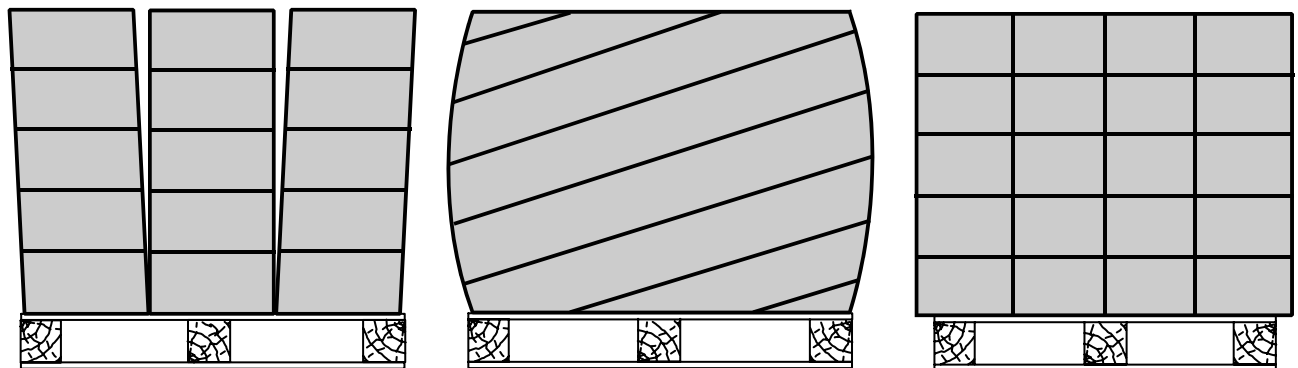

a) fanning load

b) bulging load

c) overhanging load

Figure 7 —Palletized loads that affect design clearances

6.8 Non-uniform loads

The specifier shall define the carrying capacity of the beam or cantilever arm taking into account the most unfavourable condition including any non-uniformly loaded or unsymmetrical placed pallets (see Figures 8 to 14).

NOTE 1 Not all storage equipment components are equally loaded. This would be the case for asymmetrically placed loads or if the load is carried by more than two cantilever arms (see Figure 9 where the reactions at A and B depend upon the stiffness or flexibility of the load).

Unless specified otherwise, the storage equipment designer may assume that pallets, etc. are uniformly loaded and that they are placed symmetrically onto the supports provided that the limits of load eccentricity given in prEN 15512 are fulfilled.

Where a variety of pallet sizes and/or loads are to be stored in a racking system, the specifier shall provide details of the range of pallet sizes and/or loads to the storage equipment supplier who shall ensure adequate safe support for the range of pallet sizes and /or loads.

NOTE 2 Projecting loads as in Figure 8 should not be used because of the difficulty in controlling the degree of overhang as well as the tilting stability of the load, although it is felt appropriate that it should be included in this document. The effective aisle width is also adversely affected.

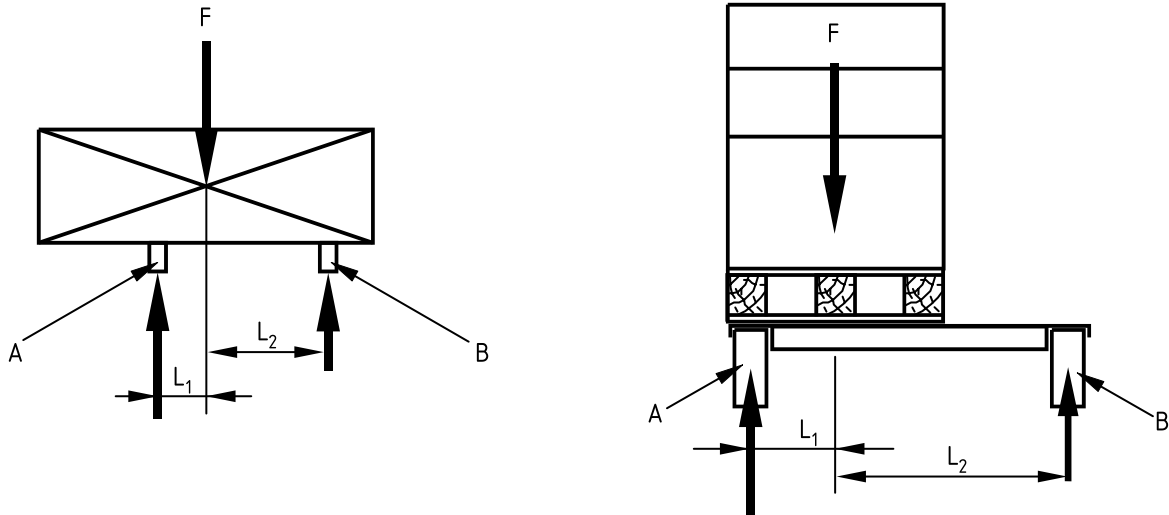

Key

- A Support beam with a larger load than support beam B
- B Support beam with a smaller load than support beam A
- F Unit load F acts at the centre of gravity of the unit load
- L_1 Distance from the centre of load to the beam A
- L_2 Distance from the centre of load to the beam B

Figure 8 — Examples of unequally loaded beams with unequal support reactions at A and B due to asymmetrically placed unit load

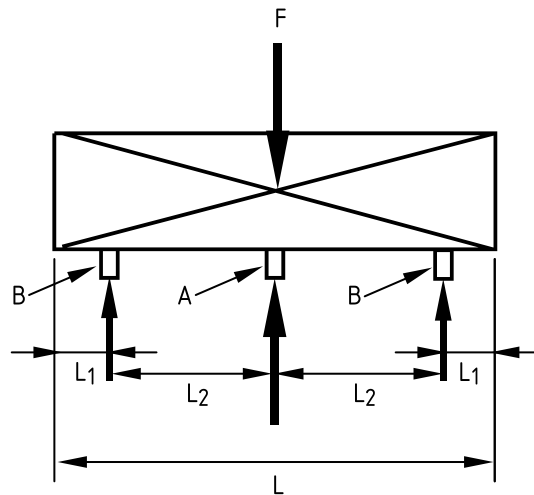

Key

- A Support beam with a larger load than support beam B
- B Support beam with a smaller load than support beam A
- L Length of unit load
- L_1 Distance from the outer beam B to the edge of load
- L_2 Distance from the centre beam A to the outer beam B

Figure 9 — Example of equally loaded beams or cantilever arms with equal support reactions at A due to symmetrically placed unit load where $L_1=L/6$ and $L_2=L/3$

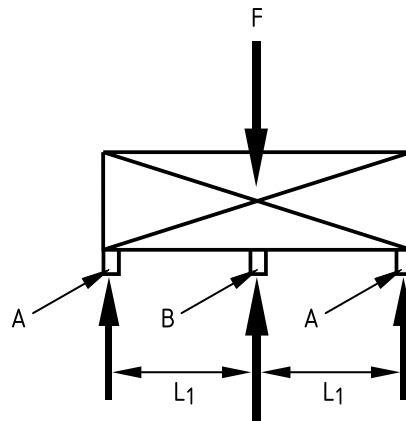

Key

- A Support beam with a smaller load than support beam B
- B Support beam with a larger load than support beam A
- F Weight of unit load
- L_1 Distance from the outer beam to the centre of load

Figure 10 — Example of unequally loaded beams or cantilever arms A and B with unequal support reactions at A and B due to unit load supported on three arms or beams

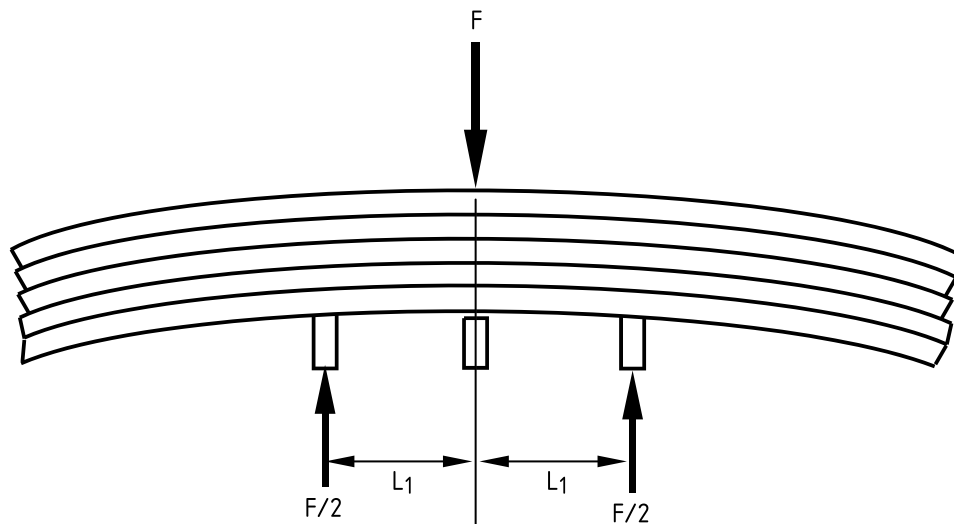

Key

- F Weight of unit load
- L_1 Distance from the outer beam to the centre of load

Figure 11 — Example of unequally loaded beams or cantilever arms with unequal support reactions due to flexible unit load with long overhang being supported on only two of the three arms or beams

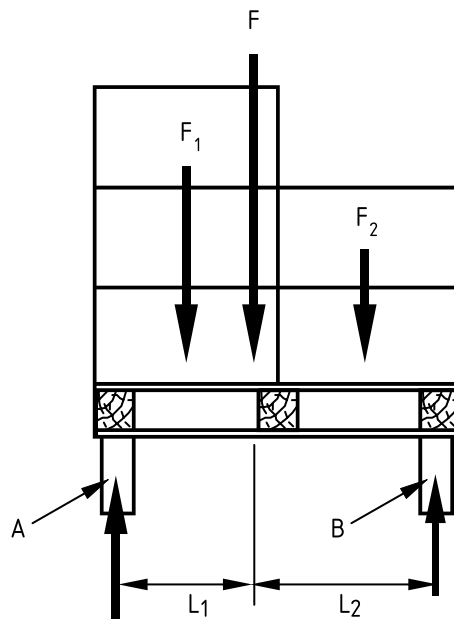

Key

- A Support beam with a larger load than support beam B
- B Support beam with a smaller load than support beam A
- F Weight of loads
- L₁ Distance from the beam A to the centre of load
- L₂ Distance from the beam B to the centre of load

Figure 12 — Non-uniform pallet loads where beam 'A' carries more load than beam 'B'

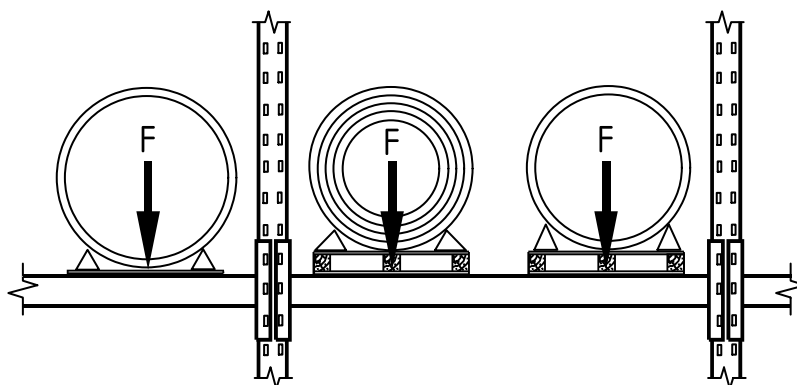

Key

- F Weight of loads

Figure 13 — Point loaded beams due to drums or coils

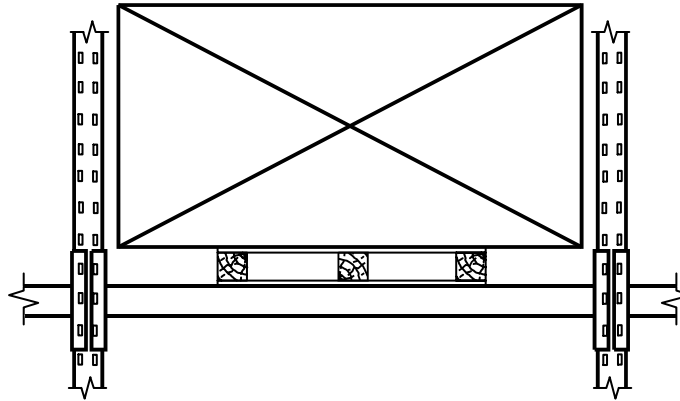

Figure 14 — Non-uniformly loaded compartment

6.9 Seismic, wind and snow loads

The location of the project and the design documents to be used, shall be stated by the specifier in order that the seismic, wind and snow loads can be evaluated for the racking or shelving structure at that specific project site.

Wind and snow loads are only applicable to rack-clad buildings and racking located outside the shelter of a fully clad building unless specified otherwise.

If the racking or shelving is to be designed to have resistance to seismic loads, the following categories of information shall be provided by the specifier relating to:

- a) site, subsoil characteristics, and the basic characteristics of the design earthquake, following specified reference documents;
- b) importance class of the building and the racking system;
- c) characteristics of the goods to be stored, including shape, weight, type of packaging and those of the pallets and load bearing accessories;
- d) interface between the building and the racking system, providing proper clearances in order to accommodate the drift space under seismic forces;
- e) sum of the specified unit loads for a run of racking for the seismic load case.

NOTE 1 The design of the floor slab and racking are interdependent.

NOTE 2 See EN 1998, and national regulations.

6.10 Environment

The minimum and maximum temperatures shall be defined by the specifier to the supplier.

Unless specified otherwise, the storage equipment supplier may assume that:

- a) storage equipment will be subject to a relative humidity greater than 65% during only a few weeks of the year measured at a temperature of 20°C;
- b) environment including the floor slab is dry, non-chemically aggressive and internal;

- c) for cold stores the cooling down procedure shall be such that no additional design requirements are needed for the storage equipment;
- d) appropriate heating and lighting will be provided over the storage area.

Where the above assumptions are not valid, the specifier shall provide information in order for the supplier to determine the quality and durability of the paint or other steel surface treatment for its protection.

NOTE The mechanical and physical properties of materials such as wood and particleboard can change under the influence of high humidity and should be considered.

7 Support by, or very close to, another structure

The specifier shall co-ordinate design activities to ensure that clearances are such that either there is no transfer of force or the effects are taken into account in designing or checking both the storage equipment and the building structure.

8 Storage system configuration

8.1 Building plans

The relevant building plans shall be provided by the user to the specifier in order to determine the racking or shelving layout. All obstructions shall be clearly shown. The building plan shall take account of the location and the absolute dimensions of the storage system including the mechanical handling equipment intended for use.

The following data in respect of the building plans shall be provided for the layout of the racking or shelving within the available clear volume of the building or bay of a building (see Figure 15):

- a) location of mechanical and electrical services, columns, bracings, fire walls, lights, windows, door openings, floor joints, emergency exits, manholes etc.;
- b) details of the area where the racking will be placed: effective clear length, width and height of this area;
- c) type and location of all fire fighting equipment;
- d) building structure tolerances and deformations;
- e) floor tolerances and deformations.

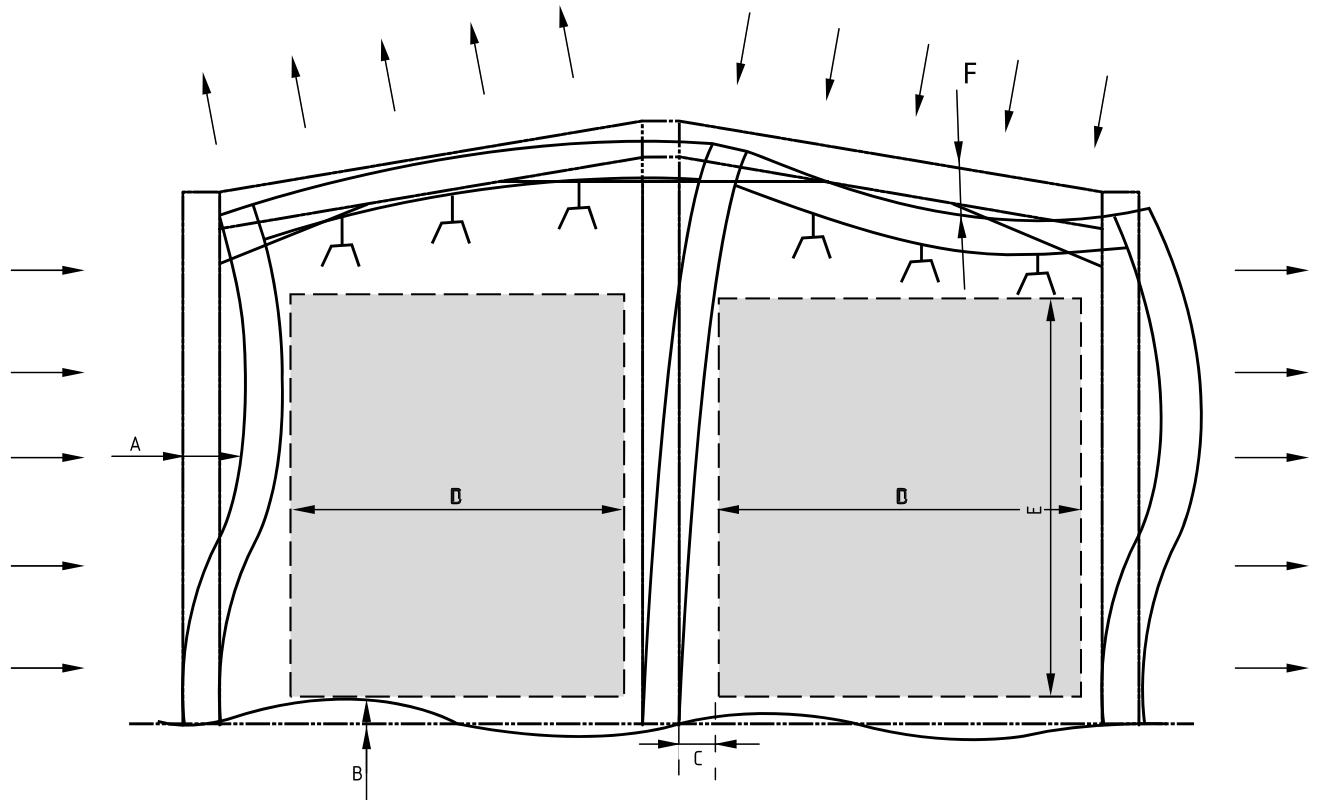

Key

- A The side wall structure wind deflection based upon National Standards design wind load
- B The highest point on the floor
- C The deformation of the column
- D The clear width between columns including deformations
- E The clear height between the floor high point and the lowest ceiling obstruction including deformations
- F The deflection of the roof

Figure 15 — Building deformations due to wind snow and seismic conditions to be used in assessing the effective volume available for racking or shelving

8.2 Precautions to reduce risk to personnel due to goods falling from racking or floors

Where there is a risk of injury to personnel from falling goods, effective preventative measures shall be defined by the specifier. These measures shall take into consideration the dimensions and weights of the goods at risk. Special attention shall be paid to passages, landings, platforms, order picking areas adjacent to racking or shelving and perforated floors.

NOTE In some cases the area at the end of a run can be protected by increasing the height of racking or shelving upright frames at the end of the run.

8.3 Operational clearances

8.3.1 General

The clearances detailed in EN 15620 for pallet racking shall be considered by the specifier in relation to the overall measurements of the pallet and load (i.e. including any pallet load overhang, see Figure 7). The specifier shall confirm the defined minimum clearances are adequate for safe operation.

8.3.2 Racking classifications for pallet racking

The specifier shall define the racking class requirement as defined in EN 15620.

NOTE Pallet racking can be classified in different groups relating to the type of handling system in use. The racking for each classification has a different standard of tolerances, clearances and deformations.

8.3.3 Horizontal and vertical clearances for pallet racking

The minimum clearances that shall be used in conjunction with this document are stated in EN 15620 and EN 15635. Intrusive stacking of unit loads by trucks shall not be considered as within the scope of this document.

8.3.4 Aisle width dimensions

The specifier shall determine the minimum aisle width from information provided by the MHE supplier together with information on the unit loads to be stored. In determining the effective width of a cantilever rack aisle, the cross aisle lateral deflection for column bending shall be taken into account.

8.4 Drive-in racking

8.4.1 Clearances relating to the placement of pallets

Adequate clearances shall be provided by the specifier for the safe placement of pallets.²

NOTE Guidance on drive-in clearances is available in FEM 10.2.03.

8.4.2 Pallet specification

The specification of pallets for drive-in racking shall include for a quality of pallet which, when loaded with the specified goods for the drive-in, shall not deflect more than 25 mm when supported on the beam rails with a minimum bearing on one side of 20 mm and a pallet span equal to the nominal clear dimension between the beam rails.

8.5 Passageways for pedestrians

Passageway clear headroom for pedestrians shall be at least 2,1 m unless otherwise specified in national regulations. Passageways for pedestrians that pass under or through racking or shelving shall be provided with overhead guarding, to prevent any stored goods from falling through the racking.

NOTE Overhead guarding will not prevent the fall of individual goods from the pallet

8.6 Passageways for trucks under or through the racking structure

The headroom in a passage shall be at least equal to the drive-through height of all means of transport using the passage plus a clearance of 250 mm.

Where trucks without overhead guards pass under or through racking or shelving, guarding shall be provided to prevent stored goods from falling through the racking. Overhead guarding shall be of adequate strength to prevent the unit loads from falling through onto the passageway below.

² Guidance on drive-in clearances is available in FEM 10.2.03 "Guidelines for specifiers of static pallet racking and shelving".

NOTE Overhead guarding will not prevent the fall of individual goods from the pallet

8.7 Means of escape

Specifiers shall design storage layouts to national requirements relating to means of escape.

8.8 Free-standing upright protectors

In determining the minimum requirement for aisle and gangway widths, consideration shall be given to the provision of effective upright protection. The minimum locations protected should be:

- a) uprights at the exposed ends of aisles and at passageways used for movement of trucks;
- b) uprights of drive-in racking next to main gangways (not drive-in or drive-through bays).

Column guards shall be made conspicuous by safety colours.

Refer to prEN 15512 for the minimum strength requirements for free standing upright protectors.

NOTE 1 If upright protection is added to an installation as a modification to an original design, it can reduce operating clearances, which in some instances can result in more difficult truck operating conditions.

NOTE 2 Most storage equipment damage results from collisions with forklift trucks. The chance of an accidental collision can be minimized by:

- i) good warehouse management;
- ii) good housekeeping;
- iii) forklift truck driver training and operator discipline;
- iv) use of safety colours or stripes and load signs;
- v) making the trucking aisles and gangways the correct width for the truck being used;
- vi) good aisle markings;
- vii) guide rails where and when appropriate;
- viii) fixed pallet stops secured to the floor.

9 Safety colours

In some countries there may be local regulations fixing safety or warning colours that shall be used for safety reasons, e.g. for upright protection.

NOTE Consideration should be given to the colour of pallet racking beams. A bright clear colour that makes the beam easily visible will enable a lift truck driver to see the beams at high levels.

10 Fire safety

The specifier shall state any particular active fire protection, means of escape or other aspect that is to be provided as part of the design.

NOTE For racking and shelving passive protection is generally not practical.

11 Storage equipment inspections

The need for regular storage equipment inspections shall be drawn to the attention of the user by the specifier in order to maintain a safe working environment (see EN 15635).

Annex A (informative)

Specifiers' and users' responsibilities

Users of storage equipment have specific responsibilities for ensuring safe conditions of operation for their workers and the stored goods.

Specifiers and users of storage equipment should have responsibility for:

- a) specification of the maximum weight and gross dimensions of the goods or unit loads to be stored and any variation in conformity which may occur;
- b) specification of the racking "foundation" properties to ensure sufficient strength and stiffness to carry the loads and for specifying any surface layer, floor fixing limitations, surface flatness, etc.;
- c) specification of specific loads applied by the material handling equipment, such as stacker cranes, fork lift trucks, use of pallet stops, pushing and sliding the goods when in contact with the storage equipment, etc.;
- d) specification of the site location for the calculation of wind, snow and seismic loads, if applicable;
- e) allowing for the minimum clearances, so that the chance of collision between loads or between load and storage equipment will be minimized. Relevant data should be provided by the supplier of the mechanical handling equipment;
- f) specifying the environment, e.g. dry, unpolluted internal or external exposed to wind and weather, in order to determine the quality and durability of the paint or other steel surface treatment for its protection;
- g) specifying surface levelness and flatness for the floor;
- h) use of the storage system in accordance with the contract specification supplied;
- i) ensuring that the detailed assembly and installation instructions provided by the storage equipment supplier are correctly implemented when the installation of the equipment is undertaken by the user or a contractor appointed by the user (installation of equipment by the supplier or manufacturer is the preferred option);
- j) specifying or providing upright protection where required;
- k) environment including the floor slab is dry, non-chemically aggressive and internal.
- l) regular inspections of the racking or shelving structure during its life to ensure that any damage incurred is repaired or damaged component replaced with identical new parts from the same manufacturer;
- m) provision of personnel, trained in the use of materials-handling equipment and the storage capabilities of the racking or shelving, to safely operate the storage facility;
- n) providing appropriate heating and lighting over the storage area;

Annex B (informative)

Suppliers' responsibilities

The suppliers' responsibilities may be summarised as follows as a non-exclusive checklist for the specifier to enable the user to confirm that the system is appropriate to their requirement and safe to operate.

The supplier should:

- a) specify the technical limitations of the system in terms of its safe operating conditions and carrying capacity considering the specifiers requirements based upon EN 15620, prEN 15629 and EN 15635. This may be done by the provision of a drawing or drawings detailing dimensions and the position of the racking with clearances and operating aisle widths shown. This will identify any specific features of the system such as imposed loads or non standard operating conditions, which have been incorporated into the design. Any load accessories provided should be identified;
- b) identify what rack protection equipment is provided as a standard with the system and what additional rack protection equipment is available as a post-installation addition;
- c) identify any truck operating types or criteria of use that have been incorporated into the layout of the racking or the design of the structure;
- d) carry out the structural design based upon prEN 15512 or when not available by the European industry's codes of practice;
- e) provide, if required, an installation service by a team of trained and experienced installers working under qualified supervision. This should include a formal post-installation check of the racking on completion of installation by a competent person and a formal handover certificate signed by a competent person presented to the client confirming that the work has been completed to the specified standard;
- f) make available for the purchase of replacement components to allow effective repair and maintenance of the racking;
- g) provide ongoing technical advice to the user of the racking, particularly relating to the effects of change of use, change of load, or reconfiguration of the rack geometry to suit new requirements;
- h) provide advice to the user of the racking on the need for regular scheduled inspection routines and a formal maintenance programme to deal with any accidental damage that may occur (see advice in EN 15635);
- i) supply load notices in approved safety colours providing information on the limitations of the system (see advice in EN 15635).

Bibliography

Further information to aid the user and the specifier can be found in the following publications:

- [1] EN 528, Rail dependent storage and retrieval equipment — Safety
- [2] EN 1993 (all parts), Eurocode 3: Design of steel structures
- [3] European Commission code 92/58/EG Safety colours 1992
- [4] European Council Directive 92/59/EEC to standardize safety signs
- [5] FEM 10.2.03 Guidelines for static steel racking and shelving
- [6] FEM 10.2.05³⁾ Safety in working with lift trucks in and around pallet racking
- [7] FEM 10.2.06, The design of hand loaded static steel shelving systems
- [8] FEM 10.2.07³⁾, The design of drive-in and drive-through pallet racking
- [9] FEM 10.2.08, The seismic design of static steel pallet racking
- [10] FEM 9.831, Calculation principles of storage and retrieval machines — Tolerances, deformations and clearances in high-bay warehouses
- [11] FEM 9.832, Calculation principles of storage and retrieval machines — Tolerances, deformations and clearances for small parts storage (without silo type)
- [12] EN 1998 (all parts), Eurocode 8: Design of structures for earthquake resistance

3) These documents are in the course of preparation and will be published in the future. They will be available for purchase online from Fachverband Foerdertechnik in the VDMA at <http://fem.vdma.-verlag.de/>

BSI - British Standards Institution

BSI is the independent national body responsible for preparing British Standards. It presents the UK view on standards in Europe and at the international level. It is incorporated by Royal Charter.

Revisions

British Standards are updated by amendment or revision. Users of British Standards should make sure that they possess the latest amendments or editions.

It is the constant aim of BSI to improve the quality of our products and services. We would be grateful if anyone finding an inaccuracy or ambiguity while using this British Standard would inform the Secretary of the technical committee responsible, the identity of which can be found on the inside front cover. Tel: +44 (0)20 8996 9000. Fax: +44 (0)20 8996 7400.

BSI offers members an individual updating service called PLUS which ensures that subscribers automatically receive the latest editions of standards.

Buying standards

Orders for all BSI, international and foreign standards publications should be addressed to Customer Services. Tel: +44 (0)20 8996 9001. Fax: +44 (0)20 8996 7001 Email: orders@bsigroup.com You may also buy directly using a debit/credit card from the BSI Shop on the Website <http://www.bsigroup.com/shop>

In response to orders for international standards, it is BSI policy to supply the BSI implementation of those that have been published as British Standards, unless otherwise requested.

Information on standards

BSI provides a wide range of information on national, European and international standards through its Library and its Technical Help to Exporters Service. Various BSI electronic information services are also available which give details on all its products and services. Contact Information Centre. Tel: +44 (0)20 8996 7111 Fax: +44 (0)20 8996 7048 Email: info@bsigroup.com

Subscribing members of BSI are kept up to date with standards developments and receive substantial discounts on the purchase price of standards. For details of these and other benefits contact Membership Administration. Tel: +44 (0)20 8996 7002 Fax: +44 (0)20 8996 7001 Email: membership@bsigroup.com

Information regarding online access to British Standards via British Standards Online can be found at <http://www.bsigroup.com/BSOL>

Further information about BSI is available on the BSI website at <http://www.bsigroup.com>.

Copyright

Copyright subsists in all BSI publications. BSI also holds the copyright, in the UK, of the publications of the international standardization bodies. Except as permitted under the Copyright, Designs and Patents Act 1988 no extract may be reproduced, stored in a retrieval system or transmitted in any form or by any means – electronic, photocopying, recording or otherwise – without prior written permission from BSI.

This does not preclude the free use, in the course of implementing the standard, of necessary details such as symbols, and size, type or grade designations. If these details are to be used for any other purpose than implementation then the prior written permission of BSI must be obtained.

Details and advice can be obtained from the Copyright and Licensing Manager. Tel: +44 (0)20 8996 7070 Email: copyright@bsigroup.com