

# Steel static storage systems — Adjustable pallet racking — Tolerances, deformations and clearances

ICS 53.080

## National foreword

This British Standard is the UK implementation of EN 15620:2008.

The UK participation in its preparation was entrusted to Technical Committee MHE/8, Steel shelving, bins and lockers.

A list of organizations represented on this committee can be obtained on request to its secretary.

This publication does not purport to include all the necessary provisions of a contract. Users are responsible for its correct application.

**Compliance with a British Standard cannot confer immunity from legal obligations.**

This British Standard was published under the authority of the Standards Policy and Strategy Committee on 31 January 2009

© BSI 2009

ISBN 978 0 580 58292 9

### Amendments/corrigenda issued since publication

Date	Comments

EUROPEAN STANDARD

**EN 15620**

NORME EUROPÉENNE

EUROPÄISCHE NORM

October 2008

ICS 53.080

English Version

**Steel static storage systems - Adjustable pallet racking -  
Tolerances, deformations and clearances**Systèmes de stockage statiques en acier - Rayonnages à  
palettes réglables - Tolérances, déformations et jeuxOrtsfeste Regalsysteme aus Stahl - Verstellbare  
Palettenregale - Grenzabweichungen, Verformungen und  
Freiräume

This European Standard was approved by CEN on 13 September 2008.

CEN members are bound to comply with the CEN/CENELEC Internal Regulations which stipulate the conditions for giving this European Standard the status of a national standard without any alteration. Up-to-date lists and bibliographical references concerning such national standards may be obtained on application to the CEN Management Centre or to any CEN member.

This European Standard exists in three official versions (English, French, German). A version in any other language made by translation under the responsibility of a CEN member into its own language and notified to the CEN Management Centre has the same status as the official versions.

CEN members are the national standards bodies of Austria, Belgium, Bulgaria, Cyprus, Czech Republic, Denmark, Estonia, Finland, France, Germany, Greece, Hungary, Iceland, Ireland, Italy, Latvia, Lithuania, Luxembourg, Malta, Netherlands, Norway, Poland, Portugal, Romania, Slovakia, Slovenia, Spain, Sweden, Switzerland and United Kingdom.

EUROPEAN COMMITTEE FOR STANDARDIZATION  
COMITÉ EUROPÉEN DE NORMALISATION  
EUROPÄISCHES KOMITEE FÜR NORMUNG**Management Centre: rue de Stassart, 36 B-1050 Brussels**

## Contents

Page

Foreword.....	5
Introduction .....	6
1 Scope .....	7
2 Normative references .....	7
3 Terms and definitions .....	8
4 Racking classes .....	13
4.1 General.....	13
4.2 Class 100, Stacker crane.....	13
4.3 Class 200, Stacker crane.....	14
4.4 Class 300, Very narrow aisle .....	14
4.4.1 General.....	14
4.4.2 Class 300A, Very narrow aisle.....	15
4.4.3 Class 300B, Very narrow aisle.....	15
4.5 Class 400, Wide aisle and narrow aisle .....	15
4.5.1 Class 400, Wide aisle.....	15
4.5.2 Class 400, Narrow aisle.....	15
5 Wide aisle and narrow aisle - Class 400.....	17
5.1 Floor tolerances .....	17
5.1.1 Definition of E.....	17
5.1.2 Limiting values for E .....	18
5.2 Installation tolerances.....	19
5.3 Deformation limits .....	22
5.3.1 Floor deformations .....	22
5.3.2 Beam deformation limits in the Y direction .....	22
5.3.3 Frame deformations in the X and Z directions .....	22
5.4 Clearances for unit loads and truck handling equipment .....	22
5.4.1 Clearances relating to the placement of unit loads .....	22
5.4.2 Horizontal lateral and vertical clearances in a bay .....	23
5.4.3 Horizontal clearance in the depth .....	25
5.4.4 Aisle width dimensions.....	27
5.4.5 Clearances for gangways .....	28
6 Very narrow aisle - Class 300 .....	29
6.1 Floor tolerances .....	29
6.1.1 Definition of E, Z and $Z_{SLOPE}$ .....	29
6.1.2 Definition $dZ$ and $dX$ .....	29
6.1.3 Definition $d^2Z$ and $d^2X$ .....	30
6.1.4 Limiting values of properties.....	31
6.2 Installation tolerances.....	32
6.2.1 General.....	32
6.2.2 Tolerance field of frames in X direction .....	36
6.3 Deformation limits .....	36
6.3.1 Floor deformations .....	36
6.3.2 Beam deformation limits in the Y direction .....	36
6.3.3 Frame deformations .....	37
6.3.4 Guide rail deformation .....	37
6.4 Clearances for unit loads and truck handling equipment.....	37
6.4.1 Clearances relating to the placement of unit loads .....	37
6.4.2 Horizontal and vertical clearances in a bay .....	38

6.4.3	Horizontal clearance in the depth.....	39
6.5	Aisle width dimensions.....	42
6.5.1	Minimum aisle clearance for truck and load.....	42
6.5.2	Lowest unit load .....	42
6.6	Pick up and deposit stations.....	42
7	Stacker crane classes 100 and 200 .....	42
7.1	Floor tolerances.....	42
7.1.1	Interdependence of rack and crane on local floor level variation .....	42
7.1.2	Floor Levelness for stacker crane floors .....	42
7.2	Installation tolerances.....	43
7.2.1	General .....	43
7.2.2	Tolerance field of frames in X direction .....	48
7.2.3	Rail fabrication and assembly tolerances.....	48
7.3	Deformation limits .....	49
7.3.1	Slab deformation due to settling and slab deflection.....	49
7.3.2	Beam deformation limitations in the Y direction.....	49
7.3.3	Top guide rail deformations .....	50
7.3.4	Frame deformations in the X and Z directions .....	51
7.3.5	Frame deformations in the X and Z directions for clad rack buildings and wind loads .....	52
7.3.6	Elastic shortening of uprights .....	54
7.4	Clearances for unit loads and crane handling equipment.....	54
7.5	Safety backstop deformations .....	54
7.5.1	Deformations .....	54
7.5.2	Clearances .....	54
8	Warehouse tolerances and deformations.....	54
Annex A (informative) Adjustable pallet racking components.....		55
Annex B (informative) General safety philosophy.....		57
B.1	General .....	57
B.2	Wide and narrow aisle width manoeuvring clearance.....	58
B.3	Intrusive stacking .....	58
B.4	Environments with additional risk.....	59
B.5	Truck requirements .....	59
B.6	Floor tolerances and deformations .....	60
B.6.1	General .....	60
B.6.2	Sloping floors .....	61
B.6.3	MHE lean.....	61
Annex C (informative) Racking measurement surveys.....		63
C.1	General .....	63
C.2	Agreed grid lines and datum's .....	63
C.3	Principal grid lines and datum's .....	63
C.4	Measurement survey reports .....	63
C.4.1	General .....	63
C.4.2	Measuring conditions .....	63
Annex D (informative) Effects of beam hogging and sagging deformations on clearances .....		64
D.1	Effects of beam hogging and sagging deformations on clearances $X_3$ , $X_4$ and $Y_1$ , $Y_2$ and $Y_3$ for non cantilevered beams.....	64
D.2	Effects of beam hogging and sagging deformations on $X_3$ , $X_4$ and $Y_1$ , $Y_2$ and $Y_3$ for cantilevered beams (P and D stations) .....	68
Annex E (informative) Additional information for determining dimensions and clearances in the depth of the rack (Z direction).....		69
E.1	Placement tolerances in the depth of the rack.....	69
E.2	Larger values of $Z_{2a}$ and $Z_{2b}$ .....	70
Annex F (informative) Additional information for very narrow aisle trucks in adjustable pallet racking .....		72
F.1	General .....	72

<b>F.2</b>	<b>Considerations for the Z direction .....</b>	<b>72</b>
<b>F.3</b>	<b>Considerations in the Y direction .....</b>	<b>73</b>
<b>F.4</b>	<b>Height selection device.....</b>	<b>73</b>
<b>F.5</b>	<b>Pick up and deposit (P and D) stations .....</b>	<b>73</b>
<b>Annex G</b>	<b>(informative) Consideration of tolerances and deformations in determining clearances .....</b>	<b>74</b>
<b>G.1</b>	<b>General.....</b>	<b>74</b>
<b>G.2</b>	<b>Storage systems other than single deep adjustable pallet racking .....</b>	<b>74</b>
<b>Annex H</b>	<b>(informative) Top guide rail tolerance recommendations .....</b>	<b>75</b>
<b>Bibliography</b>	<b>.....</b>	<b>76</b>

## **Foreword**

This document (EN 15620:2008) has been prepared by Technical Committee CEN/TC 344 “Steel static storage systems”, the secretariat of which is held by UNI.

This European Standard shall be given the status of a national standard, either by publication of an identical text or by endorsement, at the latest by April 2009, and conflicting national standards shall be withdrawn at the latest by April 2009.

Attention is drawn to the possibility that some of the elements of this document may be the subject of patent rights. CEN [and/or CENELEC] shall not be held responsible for identifying any or all such patent rights.

According to the CEN/CENELEC Internal Regulations, the national standards organizations of the following countries are bound to implement this European Standard: Austria, Belgium, Bulgaria, Cyprus, Czech Republic, Denmark, Estonia, Finland, France, Germany, Greece, Hungary, Iceland, Ireland, Italy, Latvia, Lithuania, Luxembourg, Malta, Netherlands, Norway, Poland, Portugal, Romania, Slovakia, Slovenia, Spain, Sweden, Switzerland and the United Kingdom.

## Introduction

The determination of the safe load bearing capacity of racking is a structural issue and therefore the Eurocodes are relevant, especially EN 1993. The most relevant parts for racking are EN 1993-1-1 and EN 1993-1-3.

In order to have reliable state of the art guidance for those involved in designing these products and due to the differences in the shape of the structural components, detailing and connection types, additional technical information to the Eurocodes is required.

The scope of CEN/TC 344 is to establish European Standards providing guidance for the specification, design, methods of installation, accuracy of build and also guidance for the user on the safe use of steel static storage systems.

This, together with the need for harmonised design rules, was the reason that the European Racking Federation (ERF) has taken the initiative for the CEN/TC 344. This TC is in the course of preparing a series of European Standards regarding Steel static storage systems as follows:

prEN 15512, *Steel static storage systems – Adjustable pallet racking systems – Principles for structural design*;

prEN 15629, *Steel static storage systems – The specification of storage equipment*;

prEN 15635, *Steel static storage systems – The application and maintenance of storage equipment*.

The intention is for these EN series to be published sequentially over a period of ten years.



## 1 Scope

This European Standard specifies tolerances, deformations and clearances that pertain to the production, assembly and erection of pallet racking including the interaction with floors. These tolerances, deformations and clearances are important in relation to the functional requirements and ensuring the proper interaction of the handling equipment used by personnel, trained and qualified as competent, in association with the specific type of racking system. The interaction conditions are also important in determining the reliability of the storage system to ensure that the chance of an industrial truck impact, pallet impact or a system breakdown is acceptably low. The design safety philosophy given in prEN 15512 is based upon compliance with this standard.

This European Standard gives guidance for a variety of issues including operating clearances, manufacturing, assembly and erection tolerance limitations, as well as deflection or strain deformation limitations under loads.

This European Standard is limited to single deep adjustable beam pallet racking operated with industrial trucks or stacker cranes. Drive-in, double deep and satellite systems will be considered for inclusion in the document in the future.

This European Standard specifically excludes the tolerances and deformation of the trucks and stacker cranes. It is the responsibility of the truck or stacker crane supplier and the client or user to ensure that the tolerances, deformations and clearances, as quoted in this European Standard for the racking systems, are acceptable for the safe operation of the overall system.

This European Standard gives guidance to be used in conjunction with the latest information from the truck and stacker crane suppliers regarding turning radii, tolerances and deformations of the truck and stacker cranes.

## 2 Normative references

The following referenced documents are indispensable for the application of this document. For dated references, only the edition cited applies. For undated references, the latest edition of the referenced document (including any amendments) applies.

prEN 15512 *Steel static storage systems – Adjustable pallet racking systems – Principles for structural design*

prEN 15629 *Steel static storage systems – The specification of storage equipment*

prEN ISO 3691-3, *Industrial trucks – Safety requirements and verification – Part 3: Additional requirements for trucks with elevating operator position and trucks specifically designed to travel with elevated loads (ISO/DIS 3691-3:2007)*

### 3 Terms and definitions

For the purposes of this document, the following terms and definitions apply.

#### 3.1 adjustable pallet racking APR

steelwork structure consisting of frames and beams adjustable in height, specifically designed to support pallets and unit loads

NOTE The main racking components are shown in Figure 1. See Informative Annex A for additional detailed information.

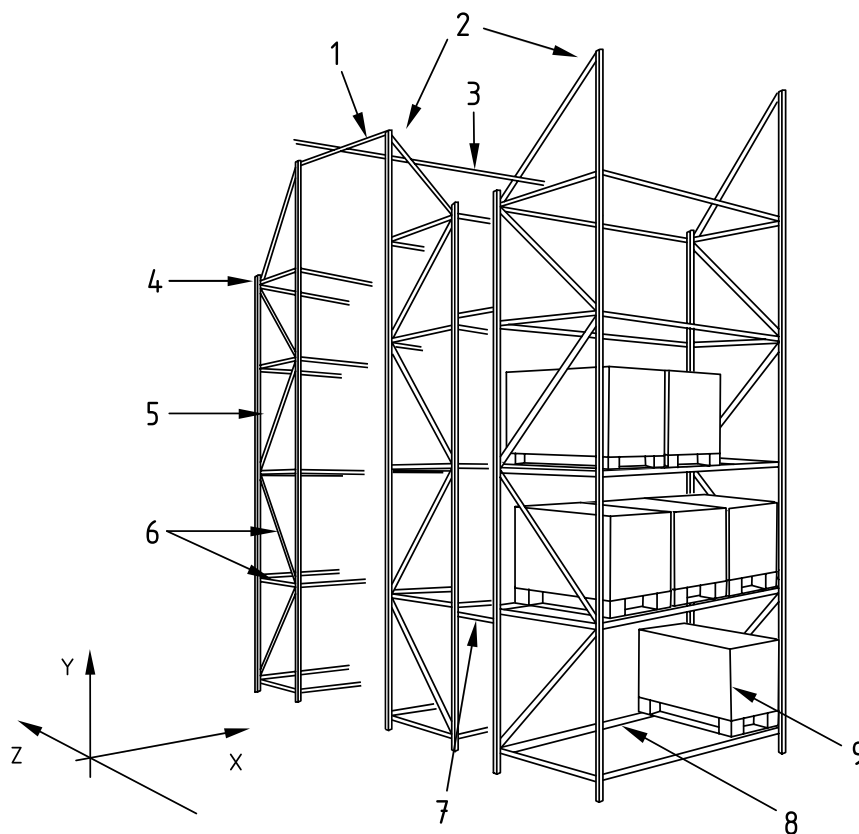

#### Key

- 1 top tie beam
- 2 double entry run
- 3 top guide rail
- 4 frame upright
- 5 single entry run
- 6 frame bracing
- 7 run spacer
- 8 beam
- 9 unit load

Figure 1 — Racking components

**3.2**  
**aisle width**

minimum dimension measured across the aisle at the floor and at any beam level between unit loads located in the nominal position or between the rack structure

NOTE See Informative Annex A for additional detailed information.

**3.3**  
**racking aisle width**

minimum dimension measured across the aisle at the floor and at any beam level between the rack structure

**3.4**  
**clearance**

nominal dimension between items

**3.5**  
**coordinate positioning**

positioning of the storage and retrieval machine using global (x and y) coordinates

**3.6**  
**deformation**

displacement due to external actions

**3.7**  
**double deep racking**

racking in which unit loads can be stored two deep from one aisle into the installation and accessed by a specially adapted long reach fork mechanism

NOTE The layout of double deep racking is shown in Figure 2.

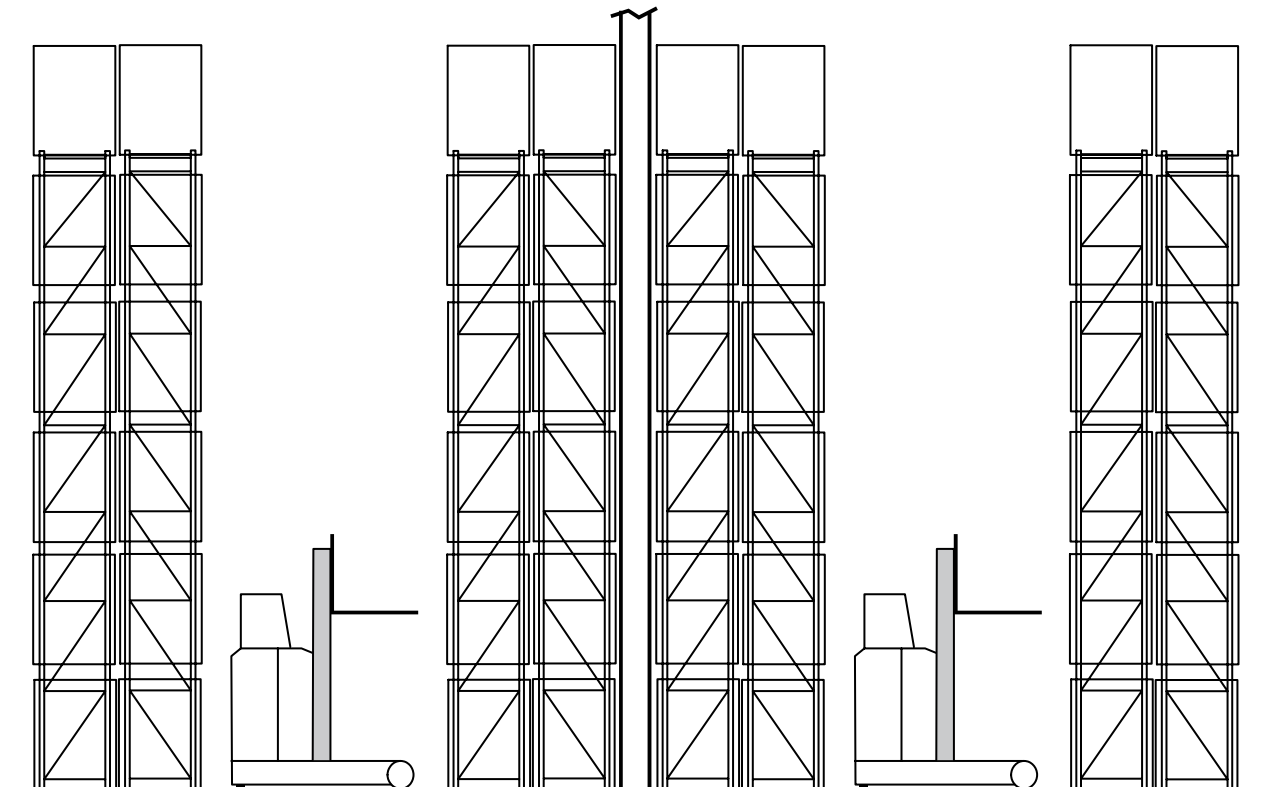

Figure 2 — Double deep racking

### 3.8 Floor surface

#### 3.8.1

##### **elevational difference**

dimension in vertical height between two points

#### 3.8.2

##### **flatness**

surface regularity characteristics over a short distance not related to a datum

#### 3.8.3

##### **levelness**

surface regularity characteristic related to a datum

### 3.9

#### **gangway**

space for movement or transport which does not give access to the picking or loading faces of the storage racking

### 3.10

#### **location fine positioning**

local adjustment of the machine with respect to the rack components in the x and/or y directions using sensors on the crane and location devices on the rack

### 3.11

#### **installers**

trained and qualified as competent personnel who assemble and build the racking at the site location

### 3.12

#### **intrusive stacking**

placement or retrieval of a pallet where the turning radius or length of a lift truck is greater than the aisle width and part of the pallet storage location concerned is used by the truck forks and load when turning to place or retrieve a pallet

### 3.13

#### **mechanical handling equipment**

##### **MHE**

mechanical equipment used to transport the unit load to be stored

### 3.14 Movement

#### 3.14.1

##### **defined movement**

##### **DM**

area where the mechanical handling equipment uses a fixed path

NOTE Defined movement areas are usually associated with high-level storage racking. The layout is designed specifically to accommodate the racking and MHE. Storage facilities often combine areas of free movement for low-level activities alongside areas of defined movement for high-level storage.

#### 3.14.2

##### **free movement**

##### **FM**

area where the mechanical handling equipment (MHE) travels freely in any direction

### 3.15

#### pick up and deposit stations

##### P and D stations

storage locations at the end of an aisle used as an interface between different types of mechanical handling equipment

NOTE The P and D station as shown in Figure 3 can be used as an interface between the unit load and handling equipment that is dedicated to the rack aisle (such as very narrow aisle [VNA] trucks or cranes) and the conveyors or free movement trucks which service the installation. The P and D station can also be used to accurately fix the location of the unit load relative to the racking. This is often used by trucks or cranes having a fixed length of fork stroke and ensures accuracy in the X and Z directions when placing the unit load onto the rack beams.

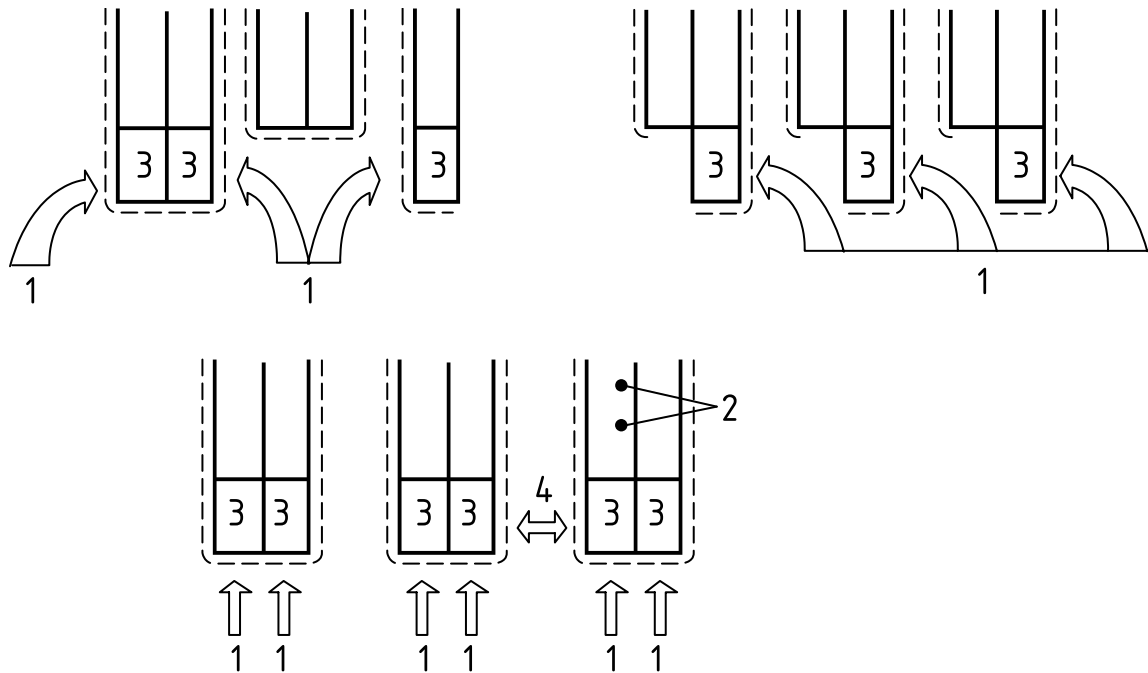

#### Key

- 1 free movement truck access
- 2 unit load positions in the racks
- 3 P and D stations
- 4 very narrow aisle (VNA)

Figure 3 — Example of P and D stations

### 3.16 Racking Classes

#### 3.16.1

##### crane racking class 100 and 200

pallet racking arranged as a very narrow aisle system and operated by a stacker crane running on a rail and stabilised at the top of the mast by a top guide rail

#### 3.16.2

##### narrow aisle racking class 400

pallet racking arranged in a similar way to wide aisle racking, but having aisles of a reduced width for use with more specialist types of lift truck

#### 3.16.3

##### very narrow aisle racking class 300

pallet racking arranged with aisles of a width to cater only for the truck and the unit load width plus an operational clearance where the truck cannot make 90° turns into the rack face for loading and off loading

### **3.16.4**

#### **wide aisle racking class 400**

pallet racking arranged to leave aisles of sufficient width to allow the fork lift truck equipment to traverse the length of the aisle and make 90° turns into the rack face for loading and off loading

### **3.17**

#### **reference directions**

directions at 90° to each other related to the orientation of the racking

NOTE The reference directions X, Y and Z are defined in Figure 1. X is the down aisle direction, Y is the vertical direction and Z is the cross aisle direction.

### **3.18**

#### **single deep racking**

pallet racking where there is only a single run of unit loads each side of the aisle, which is served by the handling equipment in that aisle

### **3.19**

#### **specification**

detailed description of the user's requirements including the racking specification and other data such as the ambient storage conditions, the floor construction, local authority requirements, etc., including all details affecting either the design of the installation or its construction

### **3.20**

#### **specifier**

person or company that provides the supplier with a specification based on the user's requirements

NOTE The specifier may be a consultant, other specialist, the user or the equipment supplier acting as the specifier.

### **3.21**

#### **stacker crane**

a storage and retrieval machine running on a rail and stabilised at the top of the mast by an upper guide rail

### **3.22**

#### **supplier**

company that supplies the storage equipment

NOTE The Company may be the original manufacturer or an intermediate company acting as a distributor.

### **3.23**

#### **tolerances**

dimensional variations from the nominal dimension or position arising from manufacture, assembly and erection of handling and storage equipment and other aspects of their environment that may affect the system such as the building, the unit load and the concrete floor

### **3.24**

#### **user**

company or person who manages and operates the installation on a daily basis and is responsible for the continuing safety of the installation

### **3.25**

#### **very narrow aisle**

#### **VNA**

aisle of a width to cater only for the truck and the unit load width plus an operational clearance where the truck cannot make 90° turns into the rack face for loading and off loading

## 4 Racking classes

### 4.1 General

Erection tolerances, deformations and clearances have been divided into four groups to cover the general requirements of the four groups of handling equipment. The racking for each classification requires a different standard of installation tolerances, deformations and minimum clearances for safe operation. See Annex B for more information on general safety philosophy.

### 4.2 Class 100, Stacker crane

Pallet racking arranged as for a very narrow aisle system but operated by a stacker crane. The aisles are wide enough only for the stacker crane or load width plus operational clearance as shown in Figure 4.

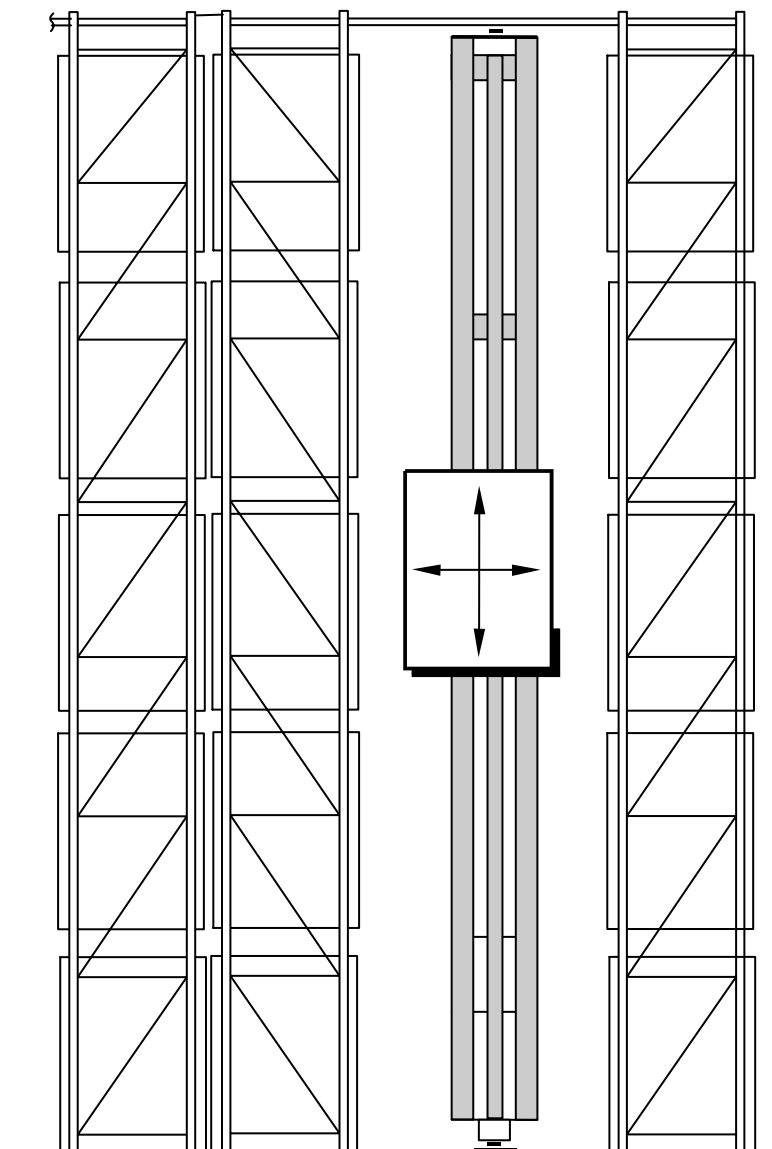

Figure 4 — Crane racking

The stacker cranes are automatically controlled, do not have a fine positioning system at the unit load storage positions and are usually for storage systems less than 18 m in height.

### 4.3 Class 200, Stacker crane

Crane operated installations where the stacker cranes are automatically controlled and have fine positioning system at the unit load storage positions. Also includes installations where the stacker crane is manually controlled.

### 4.4 Class 300, Very narrow aisle

#### 4.4.1 General

Class 300 very narrow aisle pallet racking is arranged with aisles of a width to cater only for the truck and the unit load width plus operational clearance as shown in Figure 5.

The unit loads are handled within the aisles without the need for the truck to turn bodily into the rack face.

The trucks are usually guided into and along the aisle length by guide rails or a wire guidance system and have fixed or rising cabs.

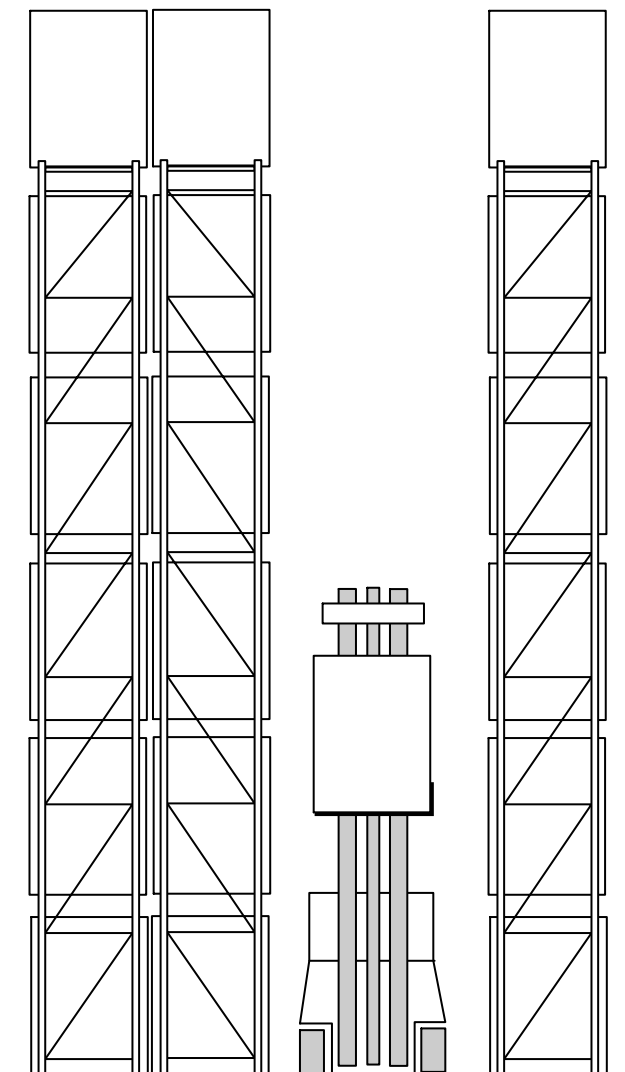

Figure 5 — Very narrow aisle racking

For truck definitions, see prEN ISO 3691-3.



#### 4.4.2 Class 300A, Very narrow aisle

Very narrow aisle installations Class 300A are where the truck operator is raised and lowered with the unit load and has manual height adjustment to position the load 'man-up'. Alternatively, the operator remains at ground level and has the use of an indirect visibility aid such as closed circuit television (CCTV) or an equivalent system to guide the operator.

#### 4.4.3 Class 300B, Very narrow aisle

Very narrow aisle installations Class 300B are those where the truck operator remains at ground level 'man-down' and does not have the use of an indirect visibility aid.

### 4.5 Class 400, Wide aisle and narrow aisle

#### 4.5.1 Class 400, Wide aisle

Wide aisle racking is arranged to leave aisles of sufficient width to allow fork lift truck equipment to traverse the length of the aisle and make 90° turns into the rack face for loading and off loading as shown in Figure 6.

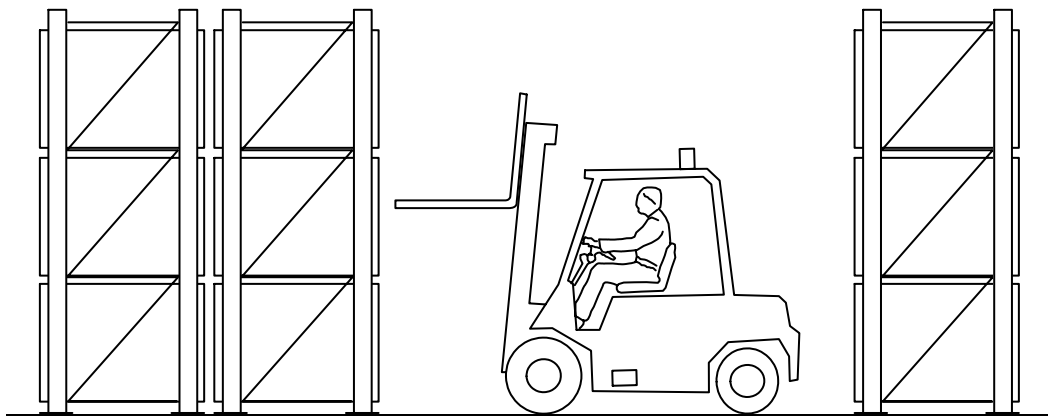

Figure 6 — Wide aisle racking with counter balanced truck

#### 4.5.2 Class 400, Narrow aisle

Narrow aisle racking, Class 400, is pallet racking arranged in a similar way to wide aisle racking but having aisles of a reduced width which can be used with more specialist types of lift truck as shown in Figure 7.

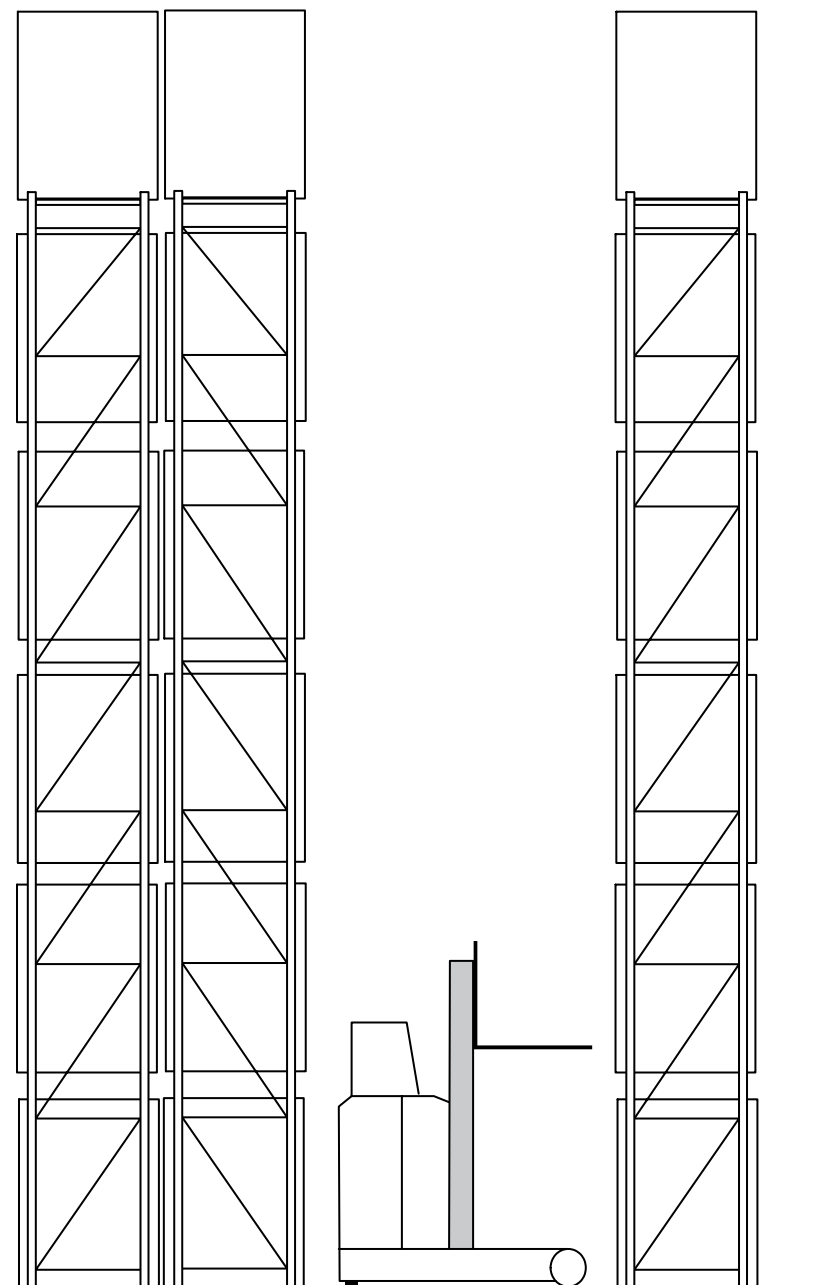

Figure 7 — Narrow aisle racking with reach truck

## 5 Wide aisle and narrow aisle - Class 400

### 5.1 Floor tolerances

#### 5.1.1 Definition of E

E is the elevational difference between adjacent fixed points 3 m apart as shown in Figure 8.

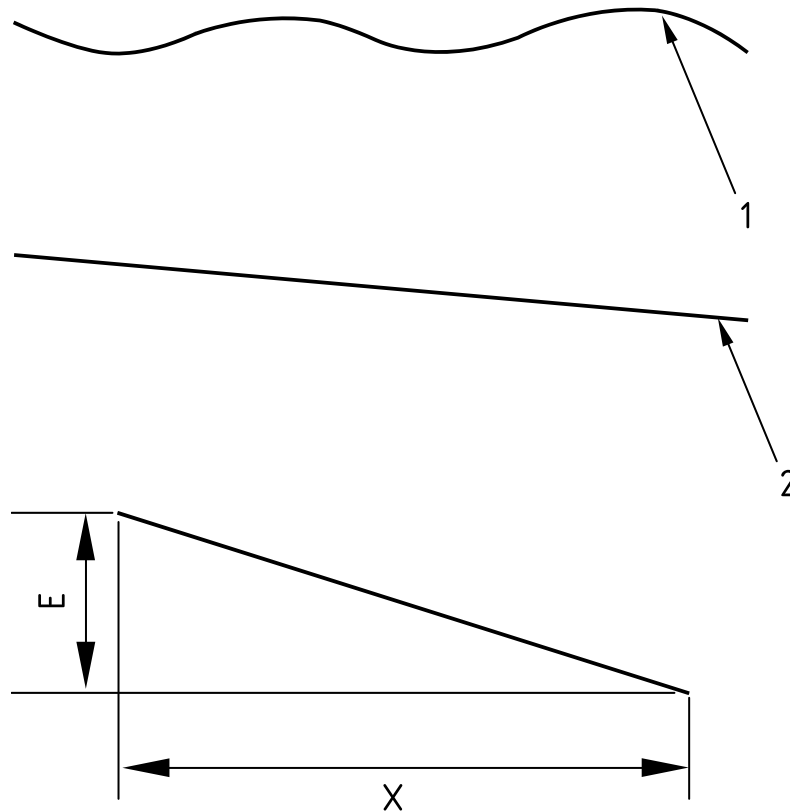

#### Key

- 1 floor profile level but not flat
- 2 floor profile flat but not level
- X 3 m
- E elevational difference between adjacent fixed points 3 m apart

Figure 8 — Flatness, levelness and elevational difference

### 5.1.2 Limiting values for E

The values of  $E_{SD}$  for horizontal internal floors shall not exceed the values given in Table 1.

Table 1 — Limiting values of  $E_{SD}$

Classification	Top beam level m	$E_{SD}$ mm
FM1 Truck without side shift	Over 13	2,25
FM2 Truck without side shift	8 to 13	3,25
FM3 Truck without side shift	Up to 8	4,0
FM3 Truck with side shift	Up to 13	4,0

NOTE Construction to FM1 is more onerous than construction to FM2 and FM3 and should only be specified for installations with a top beam level of over 13 m or where other performance requirements dictate a higher standard of floor flatness.

These limits may be relaxed subject to the specifier being satisfied that the system can be operated safely, having regard for the following items:

- a) type of MHE to be used;
- b) height of lift;
- c) localised floor gradients in areas where MHE lifting operations are carried out;
- d) time dependant changes to the floor surface.

$E_{SD}$  is the standard deviation of the L values taken on a 3 m grid.

A 3 m grid is a grid of points over the floor area 3 m apart in two directions orthogonal to the building.

All points on the 3 m grid shall be within  $\pm 15$  mm of the horizontal datum where the datum plane is across the whole or a significant part of the building.

## 5.2 Installation tolerances

The maximum allowable tolerances after erection, with the racks in the unloaded condition, shall be as stated in Tables 2 and 3 and Figure 9.

NOTE The installation tolerances are also applicable if racking is dismantled and re-erected.

**Table 2 — Tolerances measured horizontally**

<b>Horizontal tolerance limitations for X Z plane mm</b>	
<b>Measuring dimension code and description of tolerance</b>	<b>Installation tolerances for racking class 400</b>
<b>δA</b> Variation from nominal dimension of the clear entry width between two uprights at any beam level	+ / - 3
<b>δA<sub>t</sub></b> Variation from nominal dimension of the total rack length, cumulative with the number of bays 'n' measured near floor level	+ / - 3n
<b>δB<sub>0</sub></b> Variation from nominal of rack frontage with regard to the installation 'system Z datum line' concerned, measured near floor level	+ / - 10
<b>BF</b> Misalignment of opposing rack uprights across a frame	+ / - 20
<b>C<sub>x</sub></b> Out of plumb of each frame in the X direction	+ / - H/350
<b>C<sub>z</sub></b> Out of plumb of each frame in the Z direction	+ / - H/350
<b>δD</b> Variation from nominal dimension of the rack depth (single frame)	+ / - 6
<b>δE</b> Variation from nominal dimension of the aisle width near floor level	+ / - 15
<b>δF</b> Variation from nominal of the straightness of an aisle measured near floor level with regard to the 'aisle system X datum line'.	+ / - 15
<b>G<sub>z</sub></b> Straightness of the beam in the Z direction	+ / - A/400
	the larger tolerance of the following
<b>J<sub>x</sub></b> Upright straightness in the X direction between beams spaced HB apart.	+ / - 3 or + / - HB/400
<b>J<sub>z</sub></b> Initial curve of an upright frame in the Z direction	+ / - H/500
<b>T<sub>w</sub></b> Beam twist at mid span	1° per m

**Table 3 — Tolerances measured vertically**

<b>Vertical tolerance limitations for Y direction mm</b>	
<b>Measuring dimension code and description of tolerance</b>	<b>Installation tolerances, for racking class 400</b>
	the larger tolerance value of the following
<b>G<sub>y</sub></b> Straightness of the beam in the Y direction	+ / - 3 or + / - A/500
<b>δH<sub>1A</sub></b> Variation of the top of the bottom beam level above the base plate	+ / - 10
<b>δH<sub>1</sub></b> Variation of the top of any beam level H <sub>1</sub> above the bottom beam level	+ / - 5 or + / - H <sub>1</sub> /500
<b>H<sub>y</sub></b> Variation of support levels between the front and rear beams in a compartment	+ / - 10

NOTE A measurement survey may be used to measure the installation tolerances and clearances before the racking is loaded. The tolerances stated in this European Standard may not be applicable after the racking has been loaded.

Measurement surveys may be completed when required by individual contracts (see Annex C).

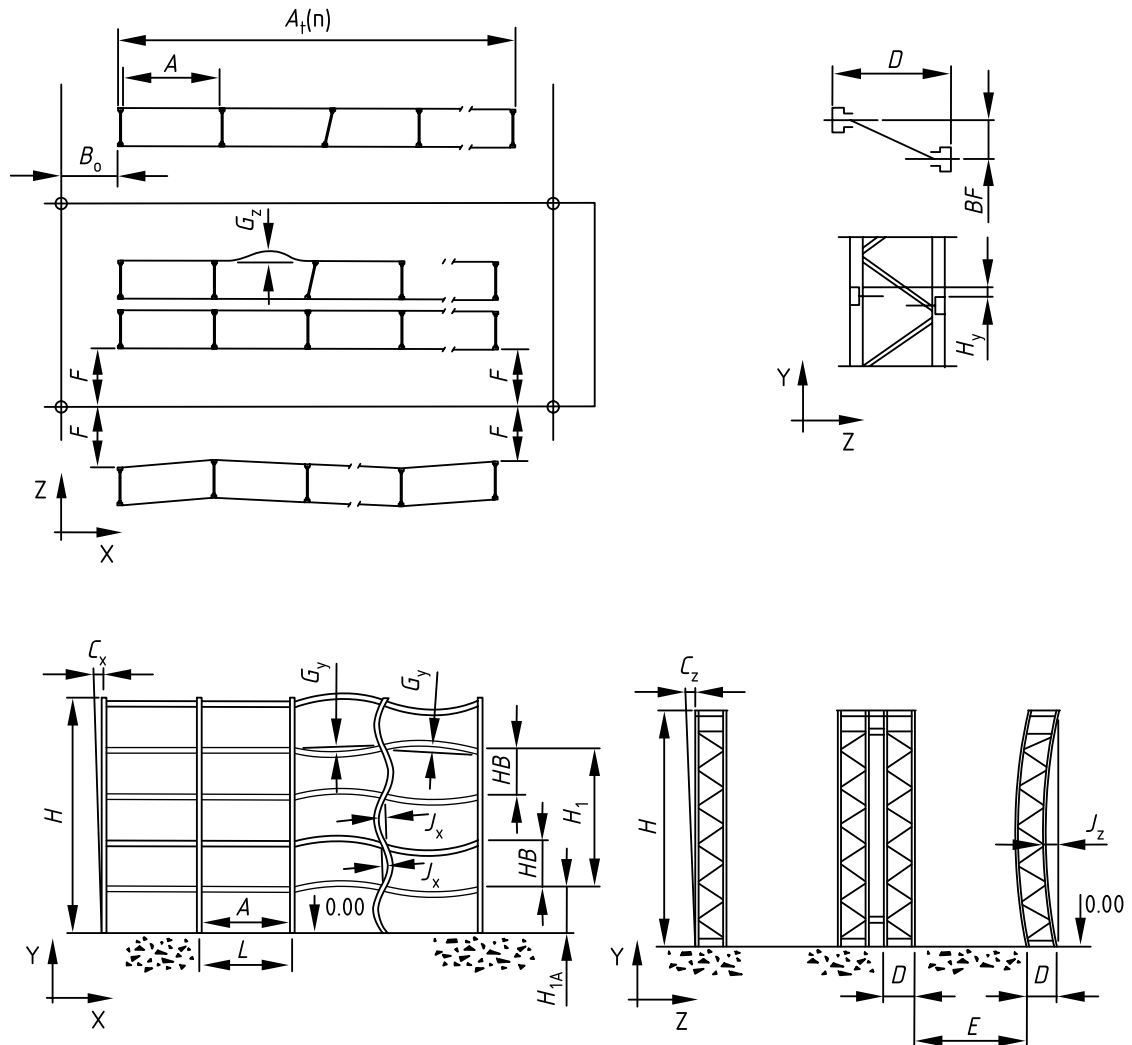

**Key**

- A** clear entry between two uprights
- B<sub>0</sub>** distance between system Z datum and front of racking
- BF** misalignment of opposing rack uprights across a frame
- C<sub>z</sub>, C<sub>x</sub>** out of plumb of upright in the z and x directions respectively
- D** rack frame depth
- E** aisle width
- F** distance from aisle system X datum to front face of upright
- G<sub>z</sub>, G<sub>y</sub>** straightness of the beam in the z and y directions respectively
- H** height from top of base plate to top of upright
- HB** height from top of beam level to top of beam level above
- H<sub>y</sub>** variation of support levels between the front and rear beams in a compartment
- H<sub>1A</sub>** height from top of base plate to top of bottom beam level
- H<sub>1</sub>** height from top of bottom beam level to top of any other beam level
- J<sub>x</sub>** upright straightness in the x direction between adjacent beam levels
- J<sub>z</sub>** initial straightness of an upright in the z direction
- L** distance from centre to centre of uprights

**Figure 9 — Horizontal and vertical tolerances**

### 5.3 Deformation limits

#### 5.3.1 Floor deformations

Relative deformations shall be included at the planning stage and information shall be given by the specifier or client to the racking supplier for evaluation of the additional stresses in the racking.

The short-term and long-term behaviour of the floor slab/sub-structure shall be taken into account when assessing the deformation.

#### 5.3.2 Beam deformation limits in the Y direction

Where beam spans are effectively continuous over two or three bays, both sagging and hogging beam deformations should be taken into account (see Annex D).

Maximum deformation of supporting beams under load shall not exceed the serviceability criteria.

Limiting deflection values shall be agreed with the specifier on a project by project basis, taking into account the specific requirements of the installation.

In the absence of any specific requirements, the following limiting deflection values should be used:

maximum vertical deflection of a beam  $L/200$

where

L is the beam span;

maximum vertical deflection of a cantilever:  $L/100$

where

L is the cantilever length from centreline of upright.

#### 5.3.3 Frame deformations in the X and Z directions

Limiting deflection values shall be agreed with the specifier on a project by project basis, taking into account the specific requirements of the installation.

In the absence of any specific requirements, the following limiting deflection values should be used.

The permissible sway (movement) deformation of rack uprights in the X or Z directions, due to the applied loads, shall not exceed 1/200 of the rack height measured from the unloaded racking upright positions on completion of erection.

### 5.4 Clearances for unit loads and truck handling equipment

#### 5.4.1 Clearances relating to the placement of unit loads

The clearances shall be considered in relation to the overall measurement of the pallet and load (i.e. including any load overhang). Maximum dimensions of the unit load shall be specified by the specifier or user.



## 5.4.2 Horizontal lateral and vertical clearances in a bay

### 5.4.2.1 Reach trucks and counter balanced trucks

The horizontal and vertical clearances for trucks shall not be less than the values shown in Figure 10 and Table 4.

NOTE In high risk environments (see B.4) as defined by the specifier, larger clearances may be required to maintain safe working conditions.

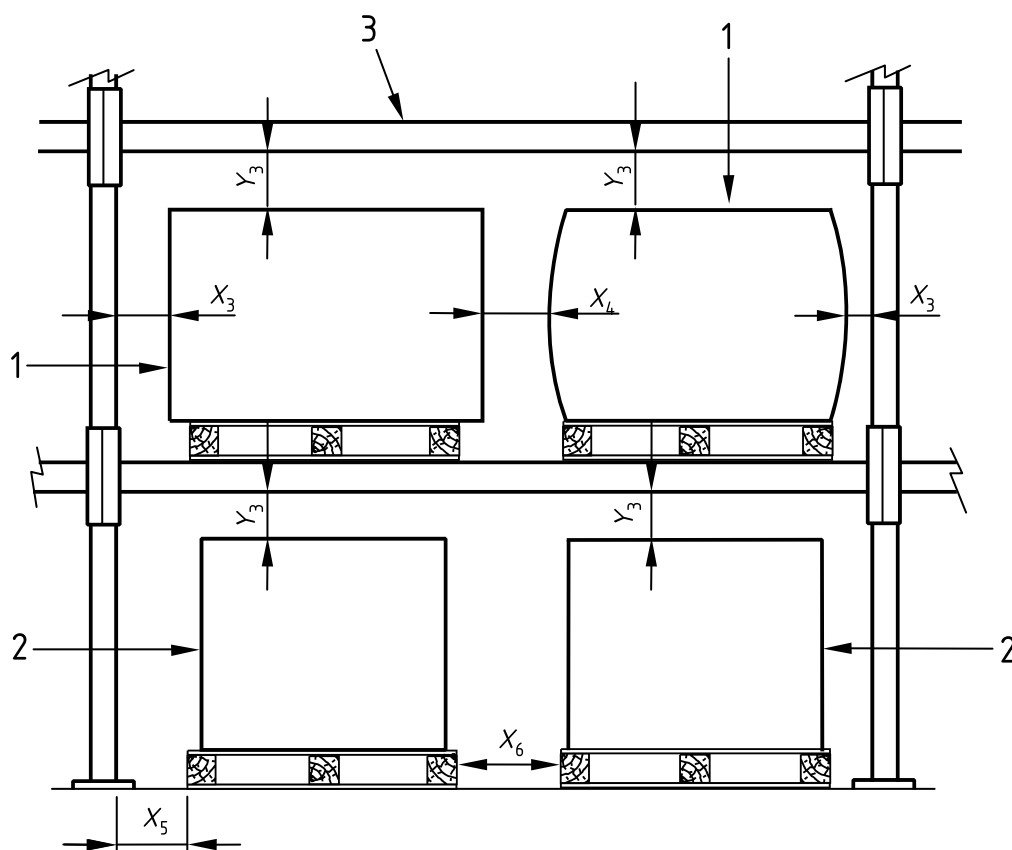

#### Key

- 1 pallet with load overhang
- 2 pallet without load overhang
- 3 beam shown without deflection

Figure 10 — Horizontal and vertical clearances for trucks

Table 4 — Horizontal and vertical clearances in a bay for trucks

Beam height $Y_h$ from ground up to beam level mm	$X_3$ $X_4$ $X_5$ $X_6$ mm	$Y_3$ mm
3000	75	75
6000	75	100
9000	75	125
13000	100	150

Smaller values of  $Y_3$ ,  $X_3$ ,  $X_4$ ,  $X_5$  and  $X_6$ , but not less than 75 mm, may be used subject to an indirect visibility aid such as closed circuit television (CCTV) or an equivalent system to guide the operator. Auto height selection or marks on the rack mast shall not be considered to be adequate justification.

At floor level the minimum clearance shall be 75 mm plus  $Y_b$  where  $Y_b$  is the required space between the floor and underside of the pallet when retrieving or depositing, as in the case of a reach truck to accommodate the height of the outriggers if the pallet or its load is wider than the dimension between the legs of the outriggers.  $Y_b$  shall be provided by the truck supplier.

NOTE Vertical clearances  $Y_3$  vary according to the height of the racking and the location of the unit loads.

For other values of  $Y_n$  the clearances can be obtained by linear interpolation.

**5.4.2.2 Straddle stacker trucks**

When picking up or depositing a unit load on the floor a clear space is left on either side of the pallet to permit the straddle legs to pass either side of the load. The straddle leg shall be clear of the frame uprights by a minimum of 75 mm as shown in  $X_7$  in Figure 11. If a bottom beam is present the straddle leg shall be clear of the underside of the beam by a minimum of 40 mm as shown in  $Y_4$  in Figure 11.

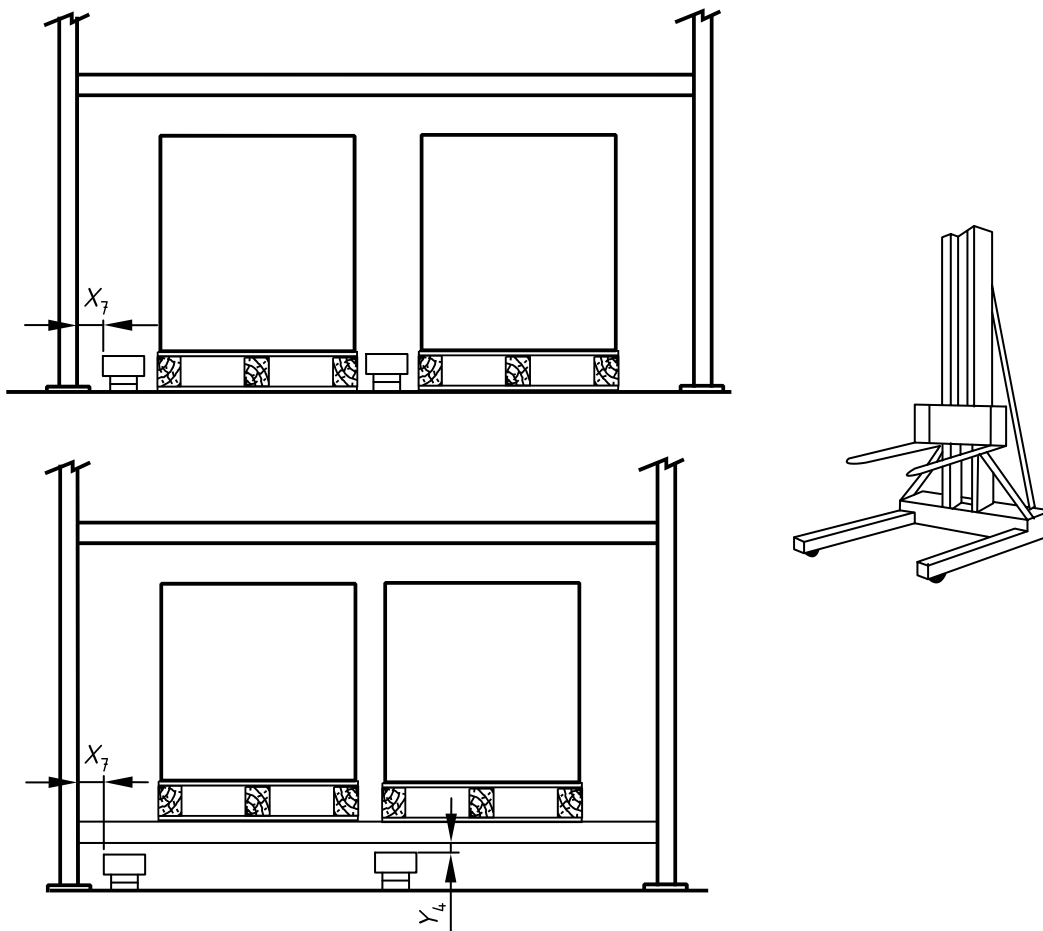

- Key**
- $X_7$  distance between the upright and the straddle truck leg
  - $Y_4$  distance between the underside of the beam and the straddle truck leg

**Figure 11 — Clearance dimensions for straddle trucks**

#### **5.4.2.3 Clearances requirements between column guards and base plates and uprights**

The following shall be used to determine the horizontal clearance requirements in a bay with base plates and column guards which are within the clearance zone:

- a) base plates and bolts up to 75 mm from the upright may be within the clearance zone with no increase in the clearance requirements;
- b) freestanding column guards up to 600 mm height from the floor slab and 25 mm to 40 mm from the upright face may be within the clearance zone with no increase in the clearance requirements;
- c) column guards connected to the upright up to 1000 mm height from the floor slab and 15 mm from the upright face may be within the clearance zone with no increase in the clearance requirements.

#### **5.4.3 Horizontal clearance in the depth**

##### **5.4.3.1 Requirements**

The horizontal clearances in the depth are shown in Figure 12.

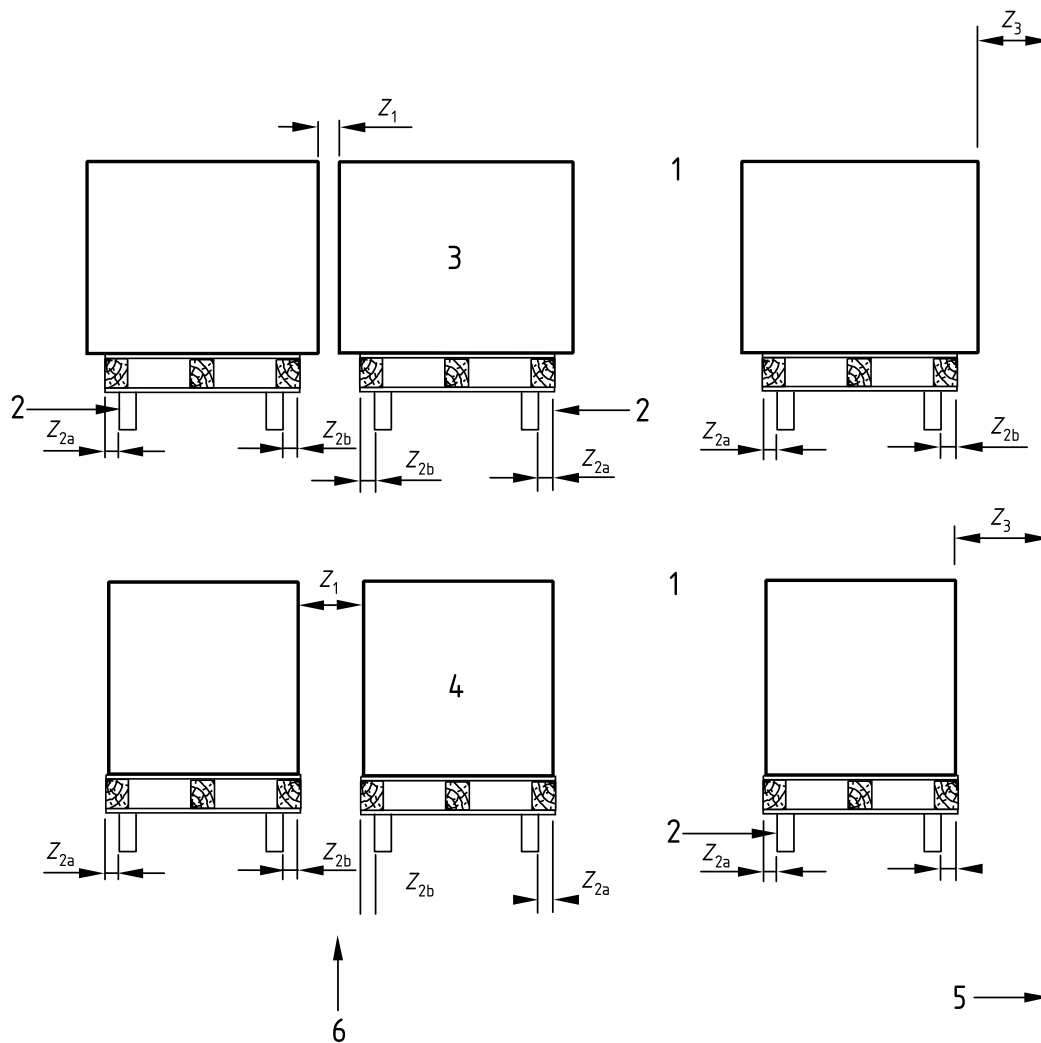

**Key**

- 1 aisle
- 2 beams
- 3 pallet with load overhang
- 4 pallet with no load overhang
- 5 safety back stop, obstructing bracing or wall behind unit loads
- 6 no obstructions behind unit loads
- $Z_1$  clearance between back to back pallets or load make up
- $Z_{2a}$ ,  $Z_{2b}$  overhang of the pallet from the front and rear beams respectively
- $Z_3$  clearance between pallet or load make up and safety back stop, obstructing bracing or wall behind unit loads

**Figure 12 — Horizontal clearances in the depth**

The horizontal clearance in the depth Z is related to:

- a) the maximum load overhang at the back of the rack;
- b) placement tolerance of the load in the Z direction ( $Z_2$ ).

In the case of back to back racks, the space  $Z_1$  between two back to back pallets and or the load make up shall therefore be greater than or equal to  $2Z_2$  but at least 100 mm. Where there is a safety back stop behind the unit load,  $Z_3$  shall be greater than or equal to  $Z_2$  but at least 50 mm.

#### **5.4.3.2 Concentric situation, manual Z positioning**

The concentric situation, with manual Z positioning of the pallet with:

- a) unit load supported by a pair of racking beams front and back;
- b) overhang of the load make up accessory (pallet) equal at the front and back beams with the overhang  $Z_2$  equal to  $50 \text{ mm} \pm 10 \text{ mm}$ .

The tolerance between the frame and beam location may be 10 mm.

The placement tolerance in the Z direction shall be  $\pm 50 \text{ mm}$  from the nominal position.

In the case of back to back racks, the nominal clearance  $Z_1$  between two back to back unit loads shall therefore be greater than or equal to 100 mm ( $2Z_2$ ).

#### **5.4.3.3 Non-concentric situation and/or $Z_2 \neq 50 \text{ mm}$**

These are special situations where the unit load overhang at the front or the back of the beams shall be specified by the specifier or truck supplier. The placement tolerance in the Z direction from the nominal position shall be specified by the specifier or truck supplier.

In the case of back to back racks, the nominal clearance  $Z_1$  between two back to back unit loads shall be greater than or equal to twice the placement tolerances in the Z direction as specified by the specifier or truck supplier but at least 100 mm.

NOTE Accessories may be used such as pallet support bars or timber decking which result in a far greater range of acceptable depths. In general when pallet support bars are used the pallet is confined within the depth of the frame with no overhang at the front or back.

See Annex E for additional information.

### **5.4.4 Aisle width dimensions**

#### **5.4.4.1 Minimum aisle clearance for 90 degree truck turning**

The 90 degree turning width of truck and load shall be determined by the truck supplier incorporating the specified design dimensions of the unit load (see Annex B).

The minimum aisle clearance shall be defined by the specifier on the basis of a risk analysis with a minimum manoeuvring allowance of 200 mm i.e. a minimum clearance on both sides of 100 mm (see Annex B).

Where there is a two way traffic system in an aisle the clearance requirements of 5.4.5 shall also apply.

#### 5.4.4.2 Lowest unit load

The aisle clearances are based on the requirement that, where the lowest unit load in the racking is supported on the concrete floor, the pallet or its load shall be placed in order not to encroach on the clear width of the aisle.

#### 5.4.4.3 Intrusive stacking

Intrusive stacking of unit loads by trucks shall not be considered as within the scope of this document.

#### 5.4.5 Clearances for gangways

For one-way only truck gangways the minimum gangway width shall be the greater of the overall truck or load width, plus 600 mm as shown in Figure 13.

For two-way truck gangways the minimum gangway width shall be the greater of twice the overall truck or twice the load width, plus 900 mm as shown in Figure 14.

Pedestrian traffic should be segregated from powered vehicle traffic whenever it can be and this may be a national requirement. Where pedestrian traffic cannot be segregated, a minimum clearance of 500 mm shall be provided on at least one side.

Dimensions in millimetres

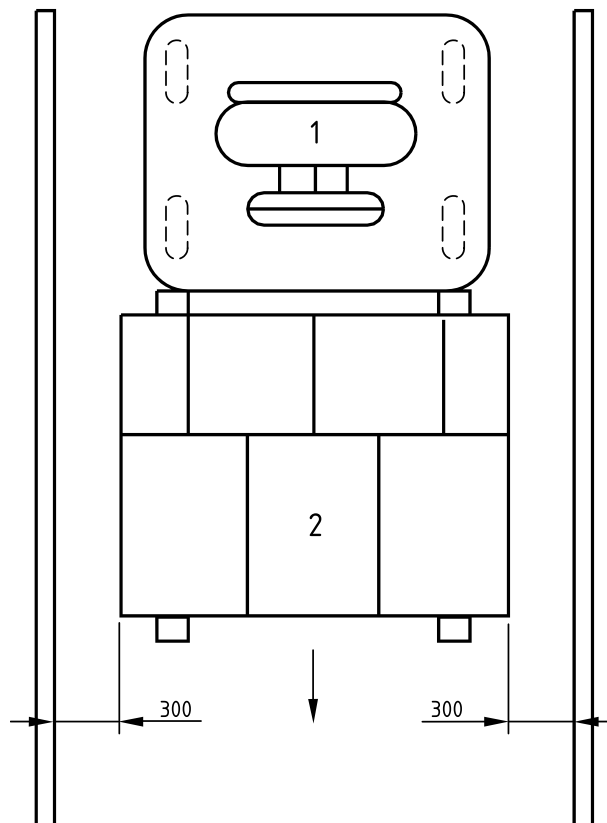

#### Key

- 1 powered vehicle
- 2 unit load

Figure 13 — Gangway clearances for a truck one-way system with no pedestrian traffic

Dimensions in millimetres

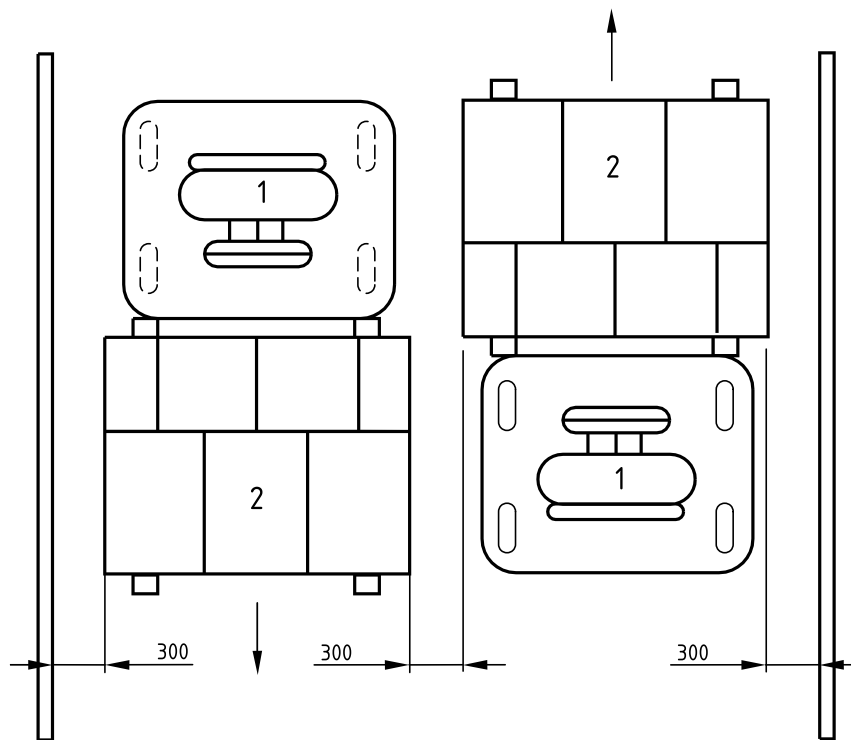

**Key**

- 1 powered vehicle
- 2 unit load

**Figure 14 — Gangway clearances for a truck two-way system with no pedestrian traffic**

## 6 Very narrow aisle - Class 300

### 6.1 Floor tolerances

#### 6.1.1 Definition of E, Z and $Z_{SLOPE}$

E is the elevational difference between adjacent fixed points 3 m apart.

Z is the dimension between the centres of truck front wheels in mm and  $Z_{SLOPE}$  is the cross aisle slope between the centres of truck front wheels in mm per m due to tolerances and deformations.

#### 6.1.2 Definition dZ and dX

dZ is the elevational difference between the actual centres of truck front wheels.

dX is the elevational difference between the centre of the front axle and the centre of the rear axle. The axle spacing is assumed to be a virtual dimension of 2 m.

dZ and dX shall be determined as shown in Figure 15.

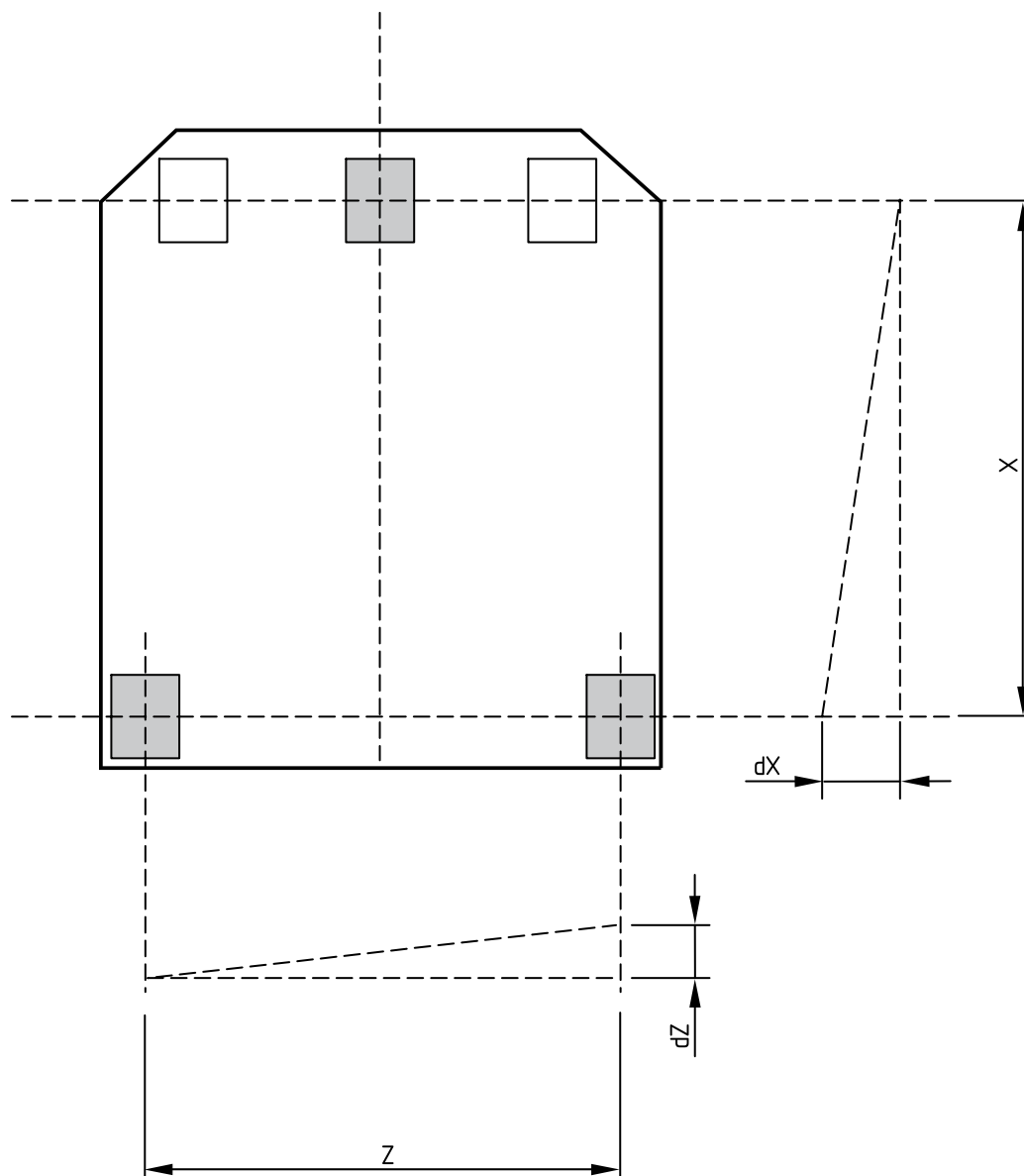

**Key**

**Z** dimension between the centres of truck front wheels in mm

**X** wheelbase or 2000 mm

**Figure 15 — Determination of  $dZ$  and  $dX$**

The data interval, the minimum measurement interval between readings, shall be less than or equal to 300 mm with additional readings within 50 mm of each side of the joints.

**6.1.3 Definition  $d^2Z$  and  $d^2X$**

$d^2Z$  is the change in  $dZ$  over a forward movement of 300 mm along the wheel tracks.

$d^2X$  is the change in  $dX$  over a forward movement of 300 mm along the wheel tracks.

$d^2Z$  and  $d^2X$  shall be determined as shown in Figure 16 and 17.



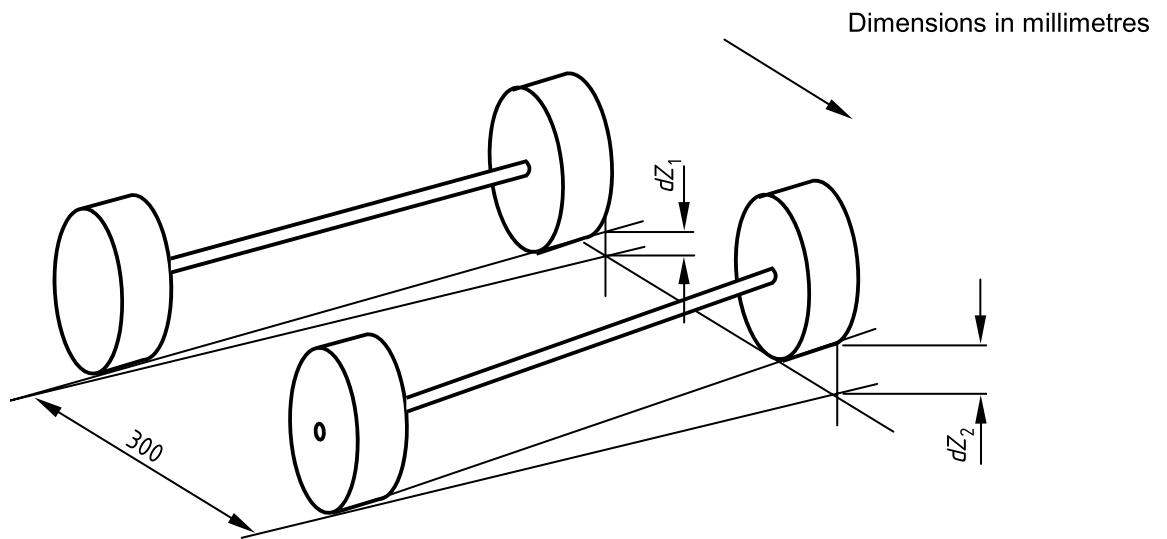

Figure 16 — Determination of  $d^2Z = dZ_2 - dZ_1$

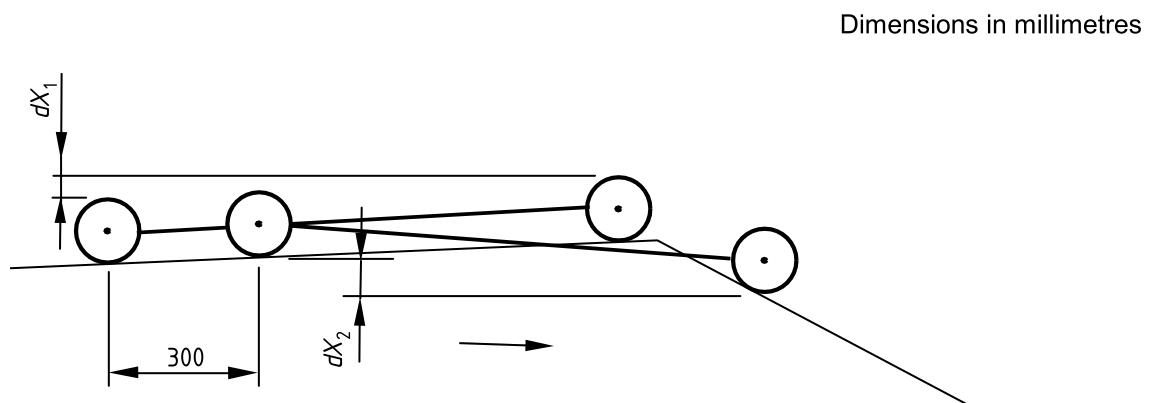

Figure 17 — Determination of  $d^2X = dX_2 - dX_1$

#### 6.1.4 Limiting values of properties

For Class 300B overall floor tolerances shall be considered on an individual project basis.

For class 300A the values of properties shall not exceed the values given in Tables 5 and 6a. The values in Table 6b are based on MHE with a wheel base of 2000 mm, for other dimensions the designer may adjust the values on a linear extrapolation basis. The values given in Table 6b or the extrapolated values shall not be exceeded.

Different floor classifications in Tables 6a and 6b may be used for the limiting values specified in the down aisle and the cross aisle directions.

NOTE The values given in Table 6a relate to the safe clearances between the MHE and the racking. The values given in Table 6b relate to the ride quality of the MHE and have a limited effect on the safety clearances between the MHE and the racking.

**Table 5 — Classification and limiting values of  $Z_{\text{SLOPE}}$  and  $E_{\text{SD}}$**

Classification	Top beam level m	$Z_{\text{SLOPE}}$ mm per m	$E_{\text{SD}}$ mm
DM 1	Over 13	1,3	3,25
DM 2	8 to 13	2,0	3,25
DM 3	Up to 8	2,5	3,25

**Table 6a — Limiting values of  $dZ$  and  $d^2Z$**

Classification	$dZ$	$d^2Z$
calculation	$Z \times Z_{\text{SLOPE}}$	$dZ \times 0,75$
DM 1	$Z \times 1,3$	$Z \times 1,0$
DM 2	$Z \times 2,0$	$Z \times 1,5$
DM 3	$Z \times 2,5$	$Z \times 1,9$

**Table 6b — Limiting values of  $dX$  and  $d^2X$**

Classification	$dX$	$d^2X$
calculation	$2 \times 1,1 \times Z_{\text{SLOPE}}$	Fixed values
DM 1	2,9	1,5
DM 2	4,4	2,0
DM 3	5,5	2,5

The floor slab level shall be within  $\pm 15$  mm of the datum.

## 6.2 Installation tolerances

### 6.2.1 General

The maximum allowable tolerances after erection, with the racks in the unloaded condition, shall be as stated in Tables 7 and 8 and Figure 18

NOTE The installation tolerances, deformations and clearances are also applicable if racking is dismantled and re-erected.

Table 7 — Tolerances measured horizontally

Horizontal tolerance limitations for X Z plane mm	
Measuring dimension code and description of tolerance	Installation tolerances for racking class 300
<b>δA</b> Variation from nominal dimension of the clear entry width between two uprights at any beam level	+ / - 3
<b>δA<sub>t</sub></b> Variation from nominal dimension of the total rack length, cumulative with the number of bays 'n' measured as near as it can be to the base plate	+ / - 3n
	The larger value of the following
<b>B</b> Misalignment of uprights across an aisle, cumulative with the number of bays 'n' measured near floor level. For class 300A this applies for the aisle uprights only  For class 300B this applies for the aisle and rear uprights	+ / - 10 or For class 300A: + / - 1,0n  For class 300B: + / - 0,5n
<b>δB<sub>0</sub></b> Variation from nominal of rack frontage at the P and D end with regard to the installation 'system Z datum line' concerned, measured near floor level	+ / - 10
<b>C<sub>x</sub></b> Out of plumb of each frame in the X direction	+ / - H/500
<b>C<sub>z</sub></b> Out of plumb of each frame in the Z direction	For no fixed stroke + / - H/500 For fixed stroke + / - H/750 <sup>a</sup>
<b>δD</b> Variation from nominal dimension of the rack depth (single or double frames)	For single frame + / - 3 For double frame + / - 6
<b>δE</b> Variation from nominal dimension of the aisle width near floor level	+ / - 5
<b>δE<sub>1</sub></b> Variation from nominal dimension of the width between guide rails	+5 / - 0
<b>δE<sub>2</sub></b> Variation from uprights on one side to guide rail	+ / - 5
<b>δF</b> Variation from nominal of the straightness of an aisle measured near floor level with regard to the 'Aisle system X datum line' or as specified by the truck supplier	+ / - 10
<b>F<sub>1</sub></b> Variation between adjacent uprights measured near floor level in the Z direction	+ / - 5
<b>G<sub>z</sub></b> Straightness of the beam in the Z direction	+ / - A/400
<sup>a</sup> H/500 is also an acceptable value provided the pallet blocks or bearers overhang the front beam by 75 mm or more and the blocks or bearers are supported on the beam.	

**Table 7 — Tolerances measured horizontally** (*continued*)

Measuring dimension code and description of tolerance	Installation tolerances for racking class 300
	The larger value of the following
<b>J<sub>x</sub></b> Upright straightness in the X direction between beams spaced HB apart.	+ / - 3 or + / - HB/750
<b>J<sub>z</sub></b> Initial curve of an upright frame in the Z direction	+ / - H/500
<b>δM</b> Tolerance of the top guide rail	Defined by the specifier or truck manufacturer.
<b>T<sub>w</sub></b> Beam twist at mid span	1° per m

**Table 8 — Tolerances measured vertically**

Vertical tolerance limitations for Y direction (mm)	
Measuring dimension code and description of tolerance	Installation tolerances for racking class 300 A and B
	The larger value of the following
<b>G<sub>y</sub></b> Straightness of the beam in the Y direction	+ / - 3 or + / - A/500
<b>δH<sub>1</sub></b> Variation of the top of any beam level H <sub>1</sub> above the bottom beam level	300A: + / - 5 or + / - H <sub>1</sub> /500 300B: + / - 3 or + / - H <sub>1</sub> /1 000
<b>δH<sub>1A</sub></b> Variation of the top of the first beam level from the floor level at each upright	+ / - 7
<b>δH<sub>3</sub></b> Tolerance of the top guide rail, if provided	If provided, defined by the supplier or truck manufacturer
<b>H<sub>y</sub></b> Variation of unit load support levels between the front and rear beams of a compartment	+ / - 10

NOTE 1 A measurement survey may be used to measure the installation tolerances before the racking is loaded. The tolerances stated in this European Standard may not be applicable after the racking has been loaded. Measurement surveys are conducted when required by individual contracts (see Annex C).

NOTE 2 The individual clearances given in this document are minimum values. The specifier should determine the overall system clearances using the clearances and tolerances as stated in this document. If greater clearances are required they should be specified by the truck supplier or specifier (see Annex F).

NOTE 3 The specifier should determine whether all tolerance values should be the worst case or whether the values can deviate from the figures stated in this document for technical or economic reasons, if the functionality of the whole system can be guaranteed (see Annex G).

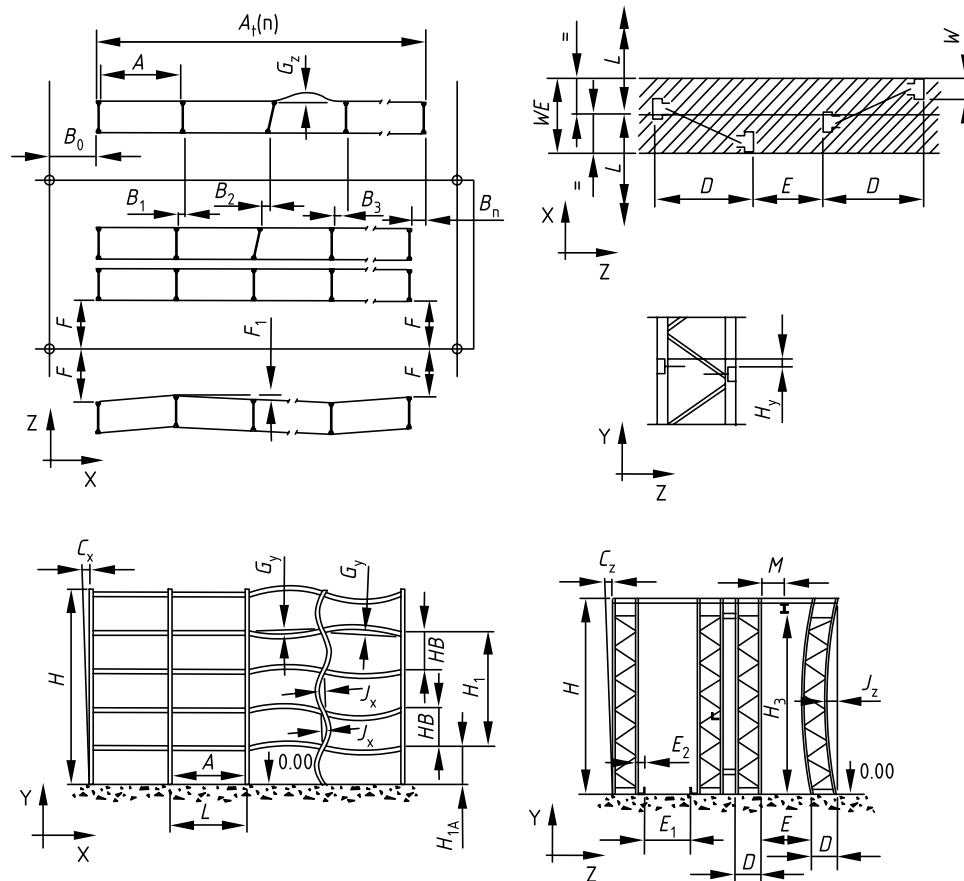

**Key**

- A** clear entry between two uprights
- B<sub>0</sub>** distance between system Z datum and front of racking
- B<sub>1</sub>, B<sub>2</sub>** misalignment of uprights across an aisle in bays 1 and 2 respectively
- C<sub>z</sub>, C<sub>x</sub>** out of plumb of upright in the z and x directions respectively
- D** rack frame depth
- E** aisle width
- E<sub>1</sub>** distance between guide rails
- E<sub>2</sub>** distance between guide rail and front of upright
- F** distance from aisle system X datum and front face of upright
- F<sub>1</sub>** variation between adjacent uprights measured near floor level in the z direction
- G<sub>z</sub>, G<sub>y</sub>** straightness of the beam in the z and y directions respectively
- H** height from top of base plate to top of upright
- HB** height from top of beam level to top of beam level above
- H<sub>y</sub>** variation of support levels between the front and rear beams in a compartment
- H<sub>1A</sub>** height from top of base plate to top of bottom beam level
- H<sub>1</sub>** height from top of bottom beam level to top of any other beam level
- J<sub>x</sub>** upright straightness in the x direction between adjacent beam levels
- J<sub>z</sub>** initial straightness of an upright in the z direction
- L** distance from centre to centre of uprights
- M** distance from front of upright to centre of top guide rail

**Figure 18 — Horizontal and vertical tolerances**

## 6.2.2 Tolerance field of frames in X direction

The tolerance field of mutually opposite frames resulting from offset of the upright, bases out of plumb and curvature of the upright sections shall not exceed WE.

This tolerance is only applicable to classification 300B.

$$WE = W + 2C_x + B_{\max} + 2J_x \quad (1)$$

where

WE is the tolerance field of mutually opposite frames resulting from offset of the upright, bases out of plumb and curvature of the upright sections;

W is the upright width;

$C_x$  is the out of plumb of upright from Table 7;

$B_{\max}$  is 10 mm or 0,5n from Table 7;

$J_x$  is the upright straightness between beam levels from Table 7.

NOTE This tolerance assists the floor level operator in visibly locating the pallets using the mutually opposite locations.

## 6.3 Deformation limits

### 6.3.1 Floor deformations

Relative floor deformations shall be included at the planning stage and information shall be given by the specifier or client to the racking supplier for evaluation of the additional stresses in the racking.

The limits given in 6.1 include the deformation of the floor slab.

The deformation of the floor slab shall be considered on an individual project basis to enable the effect of the deformation on the operation of the MHE to be evaluated and agreed with the user and the specifier of the MHE.

### 6.3.2 Beam deformation limits in the Y direction

Limiting deflection values shall be agreed with the specifier on a project by project basis, taking into account the specific requirements of the installation.

In the absence of any specific requirements, the limiting deformation values given in Table 9 should be used in the location of the fork tips.

Where beam spans are effectively continuous over two or three bays, both sagging and hogging beam deformations may need to be taken into account (see Annex D).

**Table 9 — Maximum deformation of supporting beams under load in the area of the fork tips (mm)**

BEAM TYPE	CLASS 300A mm		CLASS 300B mm	
	c <sup>c</sup>	d <sup>b</sup>	c <sup>c</sup>	d <sup>b</sup>
Normal beam	L/200 <sup>a</sup>	L/200 <sup>a</sup>	L/200 <sup>a</sup> max. 10 mm for beam levels above 6 m	L/200 <sup>a</sup>
Cantilever beam	L/100 <sup>a</sup> max. 15 mm		L/100 <sup>a</sup> max. 15 mm max. 10 mm for beam levels above 6 m	
a L is the beam span (centreline to centreline of upright). b Hogging. c Sagging.				

### 6.3.3 Frame deformations

Limiting deflection values shall be agreed with the specifier on a project by project basis, taking into account the specific requirements of the installation.

In the absence of any specific requirements, the following limiting deflection values should be used:

Sway (movement) deformation of rack uprights in the X or Z directions, due to the applied loads, should not exceed 1/200 of the rack height measured from the unloaded racking upright positions on completion of erection.

The Y axis displacement of any beam level depends upon the accumulation of compression strain in the individual upright lengths between the beam levels below the level being considered and shall be taken into account by the specifier or truck supplier when considering the height selection system.

These values shall be provided by the rack supplier.

NOTE Most suppliers of APR use high strength steels in the manufacture of their cold rolled upright sections. This means that the axial stress in the upright can be higher than for lower strength steels resulting in more elastic shortening.

### 6.3.4 Guide rail deformation

The deformation of the top and bottom guide rails is influenced by the type of very narrow aisle truck. The rail section and the size and fixing requirements shall be specified by the truck supplier.

## 6.4 Clearances for unit loads and truck handling equipment

### 6.4.1 Clearances relating to the placement of unit loads

The clearances shall be considered in relation to the maximum dimensions of the unit load which shall be specified by the supplier or user. If there is no project specific values the following clauses shall be used and the specifier shall ensure that the values are acceptable in accordance with the overall system requirements.

NOTE The following considerations should be given special attention in making any decisions on clearances in the design of racking layouts for Class 300A or 300B:

- The deformation of the VNA truck increases as the load height and reach increases. Wear on the truck mechanisms, tyres, etc. affects these deformations in all X, Y and Z directions;

— The verticality of the truck in both the X and Z directions changes as the truck moves along the aisle because of small variations in floor levels. The verticality is exaggerated by increasing heights of VNA installations.

### 6.4.2 Horizontal and vertical clearances in a bay

The minimum horizontal and vertical clearances shall be as stated in Figure 19 and Table 10. An X direction spacing of at least 75 mm shall be maintained between adjacent unit loads or between unit load and upright.

NOTE Where the turnover of unit loads is relatively high, or when other circumstances indicate it, this minimum clearance should be increased.

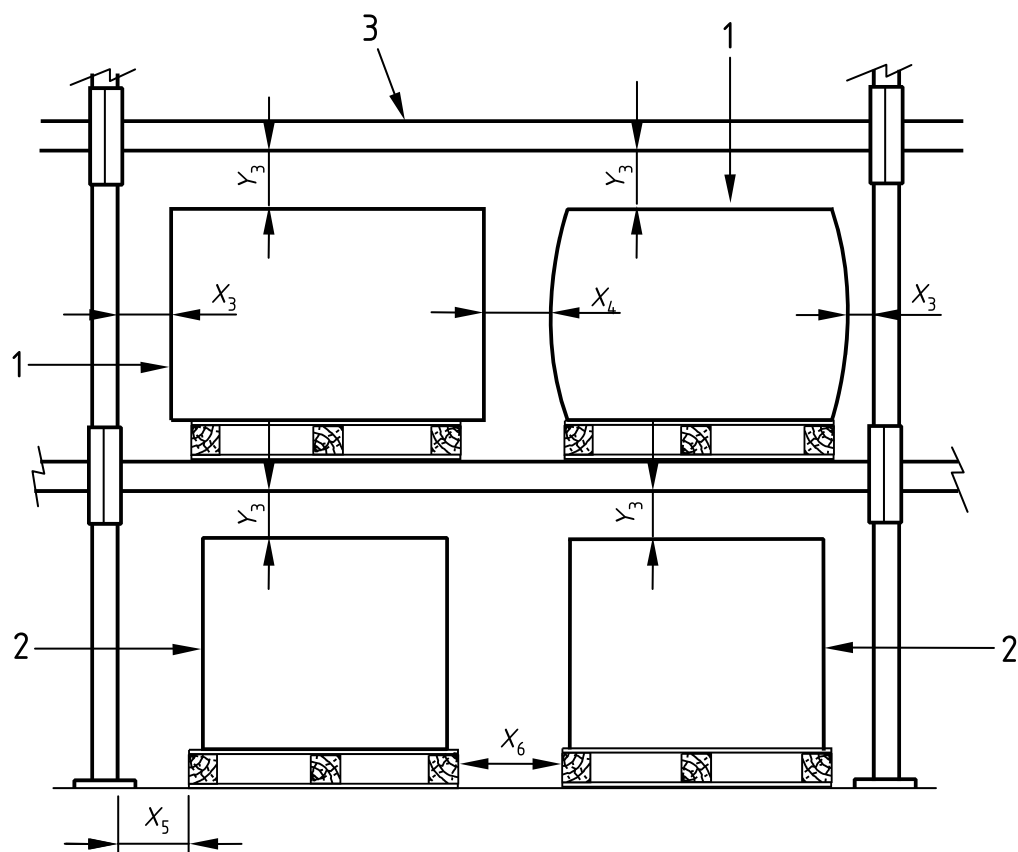

#### Key

- 1 pallet with load overhang
- 2 pallet without load overhang
- 3 beam shown without deflection

Figure 19 — Horizontal and vertical clearances



**Table 10 — Horizontal and vertical clearances**

	RACK CLASS 300A			RACK CLASS 300B		
	mm			mm		
Beam height $Y_h$ from ground up to (mm)	$X_3$ $X_5$	$X_4$ $X_6$	$Y_3$	$X_3$ $X_5$	$X_4$ $X_6$	$Y_3$
3000	75		75	75		75
6000	75		75	75		100
9000	75		75	75		125
12000	75		75	100		150
15000	75		75	100		175

For other values of  $Y_h$  the clearances may be obtained by linear interpolation.

The clearance  $Y_3$  to the first beam level shall be increased by the height of the guide rail if the truck has to place the bottom unit load on the floor over a floor mounted guide rail.

### 6.4.3 Horizontal clearance in the depth

#### 6.4.3.1 Requirements

The horizontal clearances in the depth are shown in Figure 20.

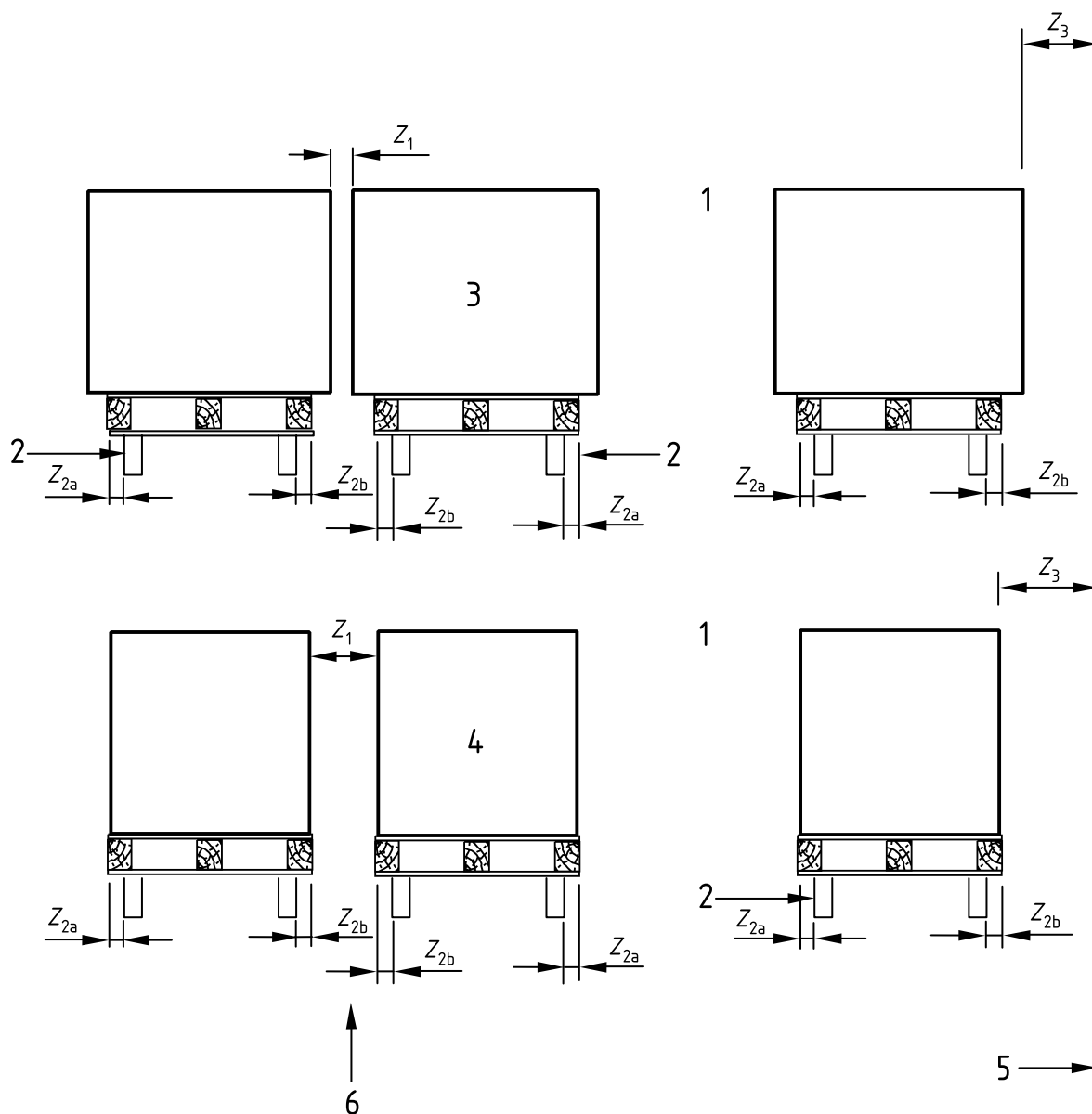

**Key**

- 1 aisle
- 2 beams
- 3 pallet with load overhang
- 4 pallet with no load overhang
- 5 safety back stop, obstructing bracing or wall behind unit loads
- 6 no obstructions behind unit loads
- $Z_1$  clearance between back to back pallets or load make up
- $Z_{2a}$ ,  $Z_{2b}$  overhang of the pallet from the front and rear beams respectively
- $Z_3$  clearance between pallet or load make up and safety back stop, obstructing bracing or wall behind unit loads

**Figure 20 — Horizontal clearances in the depth**

The horizontal clearance in the depth Z is related to:

- a) the maximum load overhang at the back of the rack;
- b) placement tolerance of the load in the Z direction ( $Z_2$ ).

In the case of back to back racks, the space  $Z_1$  between two back to back pallets and or the load make up shall be greater than or equal to  $2Z_2$  but at least 100 mm. Where there is a safety back stop behind the unit load and manual Z positioning,  $Z_3$  shall be greater than or equal to  $Z_2$  but at least 50 mm, for fixed stroke  $Z_3$  shall be supplied by the truck supplier.

#### **6.4.3.2 Concentric situation, manual Z positioning**

The concentric situation, with manual Z positioning of the pallet with:

- a) unit load supported by a pair of racking beams front and back;
- b) overhang of the load make up accessory (pallet) equal at the front and back beams with the overhang  $Z_2$  equal to 50 mm + / – 10 mm.

The tolerance between the frame and beam location may be 10 mm.

The placement tolerance in the Z direction is  $\pm 50$  mm from the nominal position.

In the case of back to back racks, the nominal clearance  $Z_1$  between two back to back unit loads shall be greater than or equal to 100 mm ( $2Z_2$ ).

#### **6.4.3.3 Concentric situation, automatic Z positioning (fixed stroke)**

The concentric situation, with automatic Z positioning of the unit load with:

- a) unit load supported by a pair of racking beams front and back;
- b) overhang of the load make up accessory (pallet) equal at the front and back beams with the overhang  $Z_2$  equal to between 50 to 75 mm + / – 10 mm (see Note below).

The placement tolerance in the Z direction from the nominal position shall be 25 mm unless specified otherwise by the specifier or truck supplier, but shall not be more than 75 mm.

In the case of back to back racks, the nominal clearance  $Z_1$  between two back to back unit loads shall be greater than or equal to twice the placement tolerance in the Z direction as specified by the specifier or truck supplier but at least 100 mm.

In order to comply with the requirement that the unit load shall be adequately supported by a pair of beams the specifier or supplier shall ensure that the following criterion is achieved.

Placement tolerance plus upright cross aisle out of plumb shall be less than or equal to  $Z_2$ .

NOTE A  $Z_2$  overhang dimension of 75 mm may be preferred with automatic Z direction positioning in order to assist in the requirement that the pallet blocks or bearers are supported by the pair of beams.

#### **6.4.3.4 Non-concentric situation and/or $Z_2 \neq 50$ mm**

These are non-concentric situations where the unit load overhang at the front or the back of the beams is specified by the specifier or truck supplier.

The placement tolerance in the Z direction from the nominal position shall be specified by the specifier or truck supplier.

In the case of back to back racks, the nominal clearance  $Z_1$  between two back to back unit loads shall be greater than or equal to twice the placement tolerances in the Z direction as specified by the specifier or truck supplier but at least 100 mm.

In order to comply with the requirement that the unit load shall be adequately supported by a pair of beams, the specifier or truck supplier shall ensure that the following criteria are achieved.

Placement tolerance plus upright cross aisle out of plumb and location tolerance shall be less than or equal to  $Z_2$ .

See Annex E for additional information.

## **6.5 Aisle width dimensions**

### **6.5.1 Minimum aisle clearance for truck and load**

The minimum aisle clearance shall be defined by the specifier or truck supplier incorporating all contributing factors (see Annex F).

### **6.5.2 Lowest unit load**

The aisle clearances are based on the requirement that, where the lowest unit load in the racking is supported on the concrete floor, the pallet or its load shall be placed in order not to encroach on the operating width of the aisle.

## **6.6 Pick up and deposit stations**

The design of the P and D stations in relation to the specified use of the VNA truck and the operational procedures shall be in accordance with the tolerance limits in X and Z direction of the load unit on the VNA truck, used in the determination of the minimum aisle and compartment clearances.

The tolerances, deformations and clearances and method of use of the P and D station shall be the responsibility of the specifier, user or supplier of the VNA truck.

**NOTE** Pick up P and D stations have a significant influence on the unit load position when placed in the racking. The unit load position when located on the P and D station with its tolerances together with the tolerances and deformations of the truck determine the position of the unit load on the truck with regard to the nominal position in the X and Z direction.

## **7 Stacker crane classes 100 and 200**

### **7.1 Floor tolerances**

#### **7.1.1 Interdependence of rack and crane on local floor level variation**

The racks shall be levelled to a datum plane (horizontal or sloping).

**NOTE** As the stacker crane on the crane rail and the rack on shims or grout are both levelled independent of the floor level, a wider range of floor tolerances may be used.

#### **7.1.2 Floor Levelness for stacker crane floors**

In the unloaded condition of the slab, the levelness shall comply with the following values with reference to a horizontal system level datum:

- up to 150 m aisle length                       $\pm 15$  mm;
- 250 m aisle length                               $\pm 20$  mm.

Linear interpolation may be used for aisle lengths between 150 m and 250 m.

## **7.2 Installation tolerances**

### **7.2.1 General**

The maximum allowable tolerances after erection, with the racks in the unloaded condition, shall be as stated in Tables 11 and 12 and Figure 21.

NOTE 1 The installation tolerances, deformations and clearances are also applicable if racking is dismantled and re-erected.

NOTE 2 A measurement survey may be used to measure the installation tolerances and clearances before the racking is loaded. The tolerances stated in this European Standard may not be applicable after the racking has been loaded. Measurement surveys are conducted when required by individual contracts (see Annex C).

NOTE 3 It is the responsibility of the specifier to determine whether all tolerance values should be the worst case or whether the values can deviate from the figures stated in this document for technical or economic reasons, if the functionality of the whole system can be guaranteed (see Annex G).

**Table 11 — Tolerances measured horizontally**

<b>Horizontal tolerance limitations for X Z plane</b> mm		
<b>Measuring dimension code and description of tolerance</b>	<b>Installation tolerances for racking class</b>	
	<b>200</b>	<b>100</b>
<b>δA</b> Variation from nominal dimension of the clear entry width between two uprights at any beam level	+ / - 3	+ / - 3
<b>δA<sub>t</sub></b> Variation from nominal dimension of the total rack length, cumulative with the number of bays 'n' measured near floor level	A <sub>t</sub> ≤ 40 m + / - 20 A <sub>t</sub> ≥ 40 m + / - 5A <sub>t</sub> /10 000	A <sub>t</sub> ≤ 40 m + / - 20 A <sub>t</sub> ≥ 40 m + / - 5A <sub>t</sub> /10 000
<b>B</b> Misalignment of opposing rack uprights across an aisle, cumulative with the number of bays 'n' measured near floor level	Part- K <sub>x</sub>	Part- K <sub>x</sub>
<b>δB<sub>0</sub></b> Variation from nominal of rack frontage at the P and D end with regard to the installation 'system Z datum line' concerned, measured near floor level	+ / - 10	+ / - 10
<b>C<sub>x</sub></b> Out of plumb of each frame in the X direction	Part- K <sub>x</sub>	Part- K <sub>x</sub>
<b>C<sub>z</sub></b> Out of plumb of each frame in the Z direction	Part- K <sub>z</sub>	Part- K <sub>z</sub>
<b>δD</b> Variation from nominal dimension of the rack depth (single or double frames)	Part- K <sub>z</sub>	Part- K <sub>z</sub>
<b>G<sub>z</sub></b> Straightness of a beam in the Z direction	+ / - A/400	+ / - A/400
<b>J<sub>x</sub></b> Upright straightness in the X direction between beams spaced h apart	Part- K <sub>x</sub>	Part- K <sub>x</sub>
<b>J<sub>z</sub></b> initial curve of an upright frame in the Z direction	Part- K <sub>z</sub>	Part- K <sub>z</sub>

Table 11 — Tolerances measured horizontally (*continued*)

Horizontal tolerance limitations for X Z plane mm		
Measuring dimension code and description of tolerance	Installation tolerances, for racking class	
	200	100
<b>K<sub>x</sub></b> Variation of mutually opposite uprights resulting from offset of the upright feet, out of plumb and pre-curved of the uprights over the total height	+ / – 15	+ / – 15
<b>K<sub>z</sub></b> Variation of uprights in a row resulting from offset of the upright feet, out of plumb and pre-curved of the uprights over the total height	+ / – 15	+ / – 15
<b>δM</b> Variation from nominal of the top guide rail with regard to the 'Aisle system X Y datum plane' at each support point of the rail for each length of 50 m	See 7.2.3. The tolerances of the guide rail section itself are according to European manufacturing standards for the section.	See 7.2.3. The tolerances of the guide rail section itself are according to European manufacturing standards for the section.
<b>δS</b> Variation in safety back stop location in relation to the edge of the rear upright	+ / – 5	+ / – 5
<b>T<sub>w</sub></b> Beam twist at mid span	1° per m	1° per m
<p>NOTE 1 If the pallet or palletised goods protrude beyond the upright frame, tolerance(s) D and/or J<sub>z</sub> is/are irrelevant unless the 'Reading Depth' of a photo cell in a detection system is critical.</p> <p>NOTE 2 If all the uprights each side of an aisle lean in one direction, then, if this is the same direction as any lean in the crane mast, this is beneficial. If, however, the crane mast leans in the reverse direction then the mast lean can be corrected to improve the tolerance.</p>		

**Table 12 — Tolerances measured vertically**

<b>Vertical tolerance limitations for Y direction (mm)</b>		
<b>Measuring dimension code and description of tolerance</b>	<b>Installation tolerances for racking class</b>	
	200	100
<b>δH<sub>B</sub></b> Distance between two adjacent beam levels from the nominal dimension	+ / - 3	+ / - 3
<b>δH<sub>2</sub></b> Variation in the height between the lowest and highest beam level	0,5 % of the height H <sub>2</sub>	0,5 % of the height H <sub>2</sub>
<b>δH<sub>2A</sub></b> Variation of the top of the lowest beam level in relation to the system datum plane	+ / - 5	+ / - 5
<b>δH<sub>3</sub></b> Deviation from nominal of the distance between the lower edge of the upper guide rail and a horizontal system X-Z datum plane	+ 10 / - 5	+ 10 / - 5
<b>K<sub>y</sub></b> Level tolerance at each individual level of all support beams at that level situated on both sides of an individual aisle and all aisles served by the same machine	+ / - 10	+ / - 5
<b>H<sub>y</sub></b> Variation of beam support levels between the top surface of the rear supporting beam and the top surface of the foremost beam	+ 2 / - 4	+ 2 / - 4
NOTE H <sub>2</sub> refers to each beam level that can be accessed by the same stacker crane. Where a crane cannot be transferred from one aisle to another, then the tolerance applies to the levels of all the beams in one aisle.		



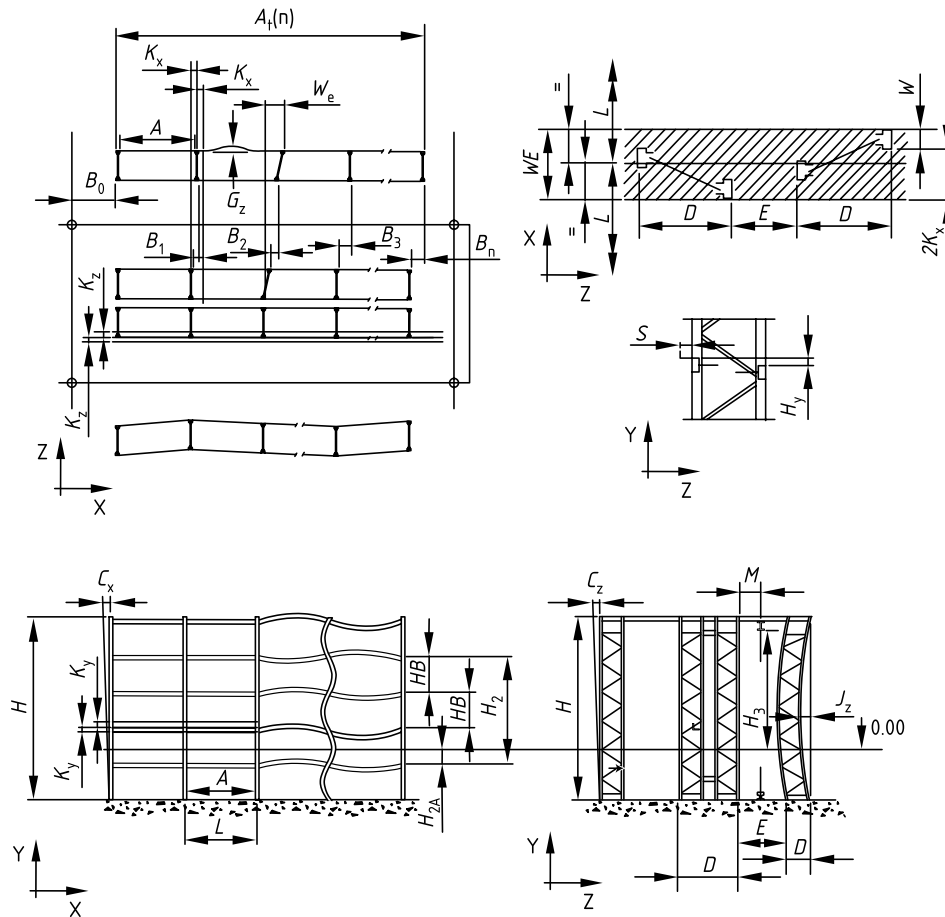

**Key**

- A** clear entry between two uprights
- $A_i(n)$**  total rack length
- $B_1, B_2$**  misalignment of uprights across an aisle in bays 1 and 2 respectively
- $C_z, C_x$**  out of plumb of upright in the **z** and **x** directions respectively
- D** rack frame depth (single or double frames)
- E** aisle width
- H** height from top of base plate to top of upright
- HB** height from top of beam level to top of beam level above
- $H_y$**  variation of support levels between the front and rear beams in a compartment
- $H_{2A}$**  height from system datum **X** to top of bottom beam level
- $H_2$**  height from lowest beam level to top beam level
- $H_3$**  height from system datum **X** to bottom of top guide rail
- $J_z$**  initial straightness of an upright in the **z** direction
- $K_x$**  variation of mutually opposite uprights
- $K_y$**  level tolerance at each individual level of all support beams at that level on both sides of an individual aisle and all aisles served by the same crane
- $K_z$**  variation of uprights in a row
- L** distance from centre to centre of uprights
- M** distance from front of upright to centre of top guide rail
- S** distance from safety back stop to face of back upright

**Figure 21 — Rack system datum's and tolerance dimensions**

### 7.2.2 Tolerance field of frames in X direction

The tolerance field of mutually opposite frames resulting from offset of the upright bases out of plumb and curvature of the upright sections shall not exceed WE.

$$WE = W + 2K_x \quad (2)$$

where

WE is the tolerance field of mutually opposite frames resulting from offset of the upright, bases out of plumb and curvature of the upright sections;

W is the upright width;

$K_x$  is the variation of mutually opposite frames from Table 11.

### 7.2.3 Rail fabrication and assembly tolerances

The fabrication and assembly tolerance requirements for the top guide rail as shown in Figure 22 shall be as follows:

When not loaded, the top guide rail shall comply with the following installation tolerance requirements:

- a) At adjacent top tie beam connection points the guide rail shall be within  $L/750$  of the reference axis.
- b) At top tie beam connection points over the aisle length, the guide rail shall be within  $\pm 5$  mm of the reference axis.

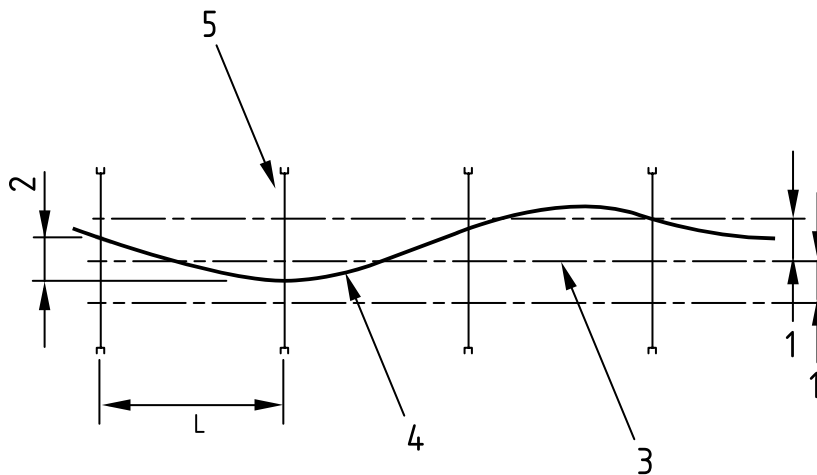

#### Key

- 1 5 mm maximum rail deviation from reference axis at top tie connecting points over aisle length
- 2  $L/750$  maximum rail deviation over 2 adjacent top tie beam rail connections
- 3 reference axis
- 4 crane rail
- 5 top tie
- L distance between 2 adjacent top tie beam rail connections

**Figure 22 — Tolerances for the upper guide rail (plan view)**

Any difference in rail section dimensions at joints in the running area of guide rollers shall be ground to less than 1,0 mm bow over a measured length of 200 mm.

There shall be no rolling inscriptions (i.e. raised lettering) on the running surfaces.

The type and sizing of the top guide rail, (generally a standard hot rolled steel section) and its method of connection shall be the responsibility of the stacker crane supplier.

The specification shall include:

- a) the rail span with a minimum value of 2mm;
- b) the bending stiffness of the top tie beams to which the rail shall be connected;
- c) the equivalent static crane guide wheel forces;
- d) the wheel spacing.

(See Annex H for additional manufacturing recommendations.)

### **7.3 Deformation limits**

#### **7.3.1 Slab deformation due to settling and slab deflection**

##### **7.3.1.1 General**

Deflection of the floor slab results in additional stresses and inclination of the rack structure and can be considerable.

Deflection of the floor slab shall be included at the planning stage and information shall be provided by the specifier or client to the racking supplier for evaluation of the additional stresses in the racking.

Deflection of the floor slab shall be included at the planning stage by the specifier or client and added to the clearances and deformations as required for the specific project.

##### **7.3.1.2 Conditions for a quasi-rigid floor slab**

The floor slab can be regarded to be quasi-rigid, which implies that the deformations of the floor slab do not affect the structural behaviour (deformations and stresses) of the rack, if the following is fulfilled:

- a) the angular rotation at any location of the floor slab within the rack area shall not exceed  $\arctan (1/2\ 000)$ ;
- b) the overall vertical deformation shall not exceed 1/2 000 of the total storage length;
- c) the overall vertical deformation shall not exceed 1/2 000 of the total storage width.

The short-term and long-term behaviour of the floor slab/sub-structure shall be taken into account when assessing the deformation.

#### **7.3.2 Beam deformation limitations in the Y direction**

Maximum deformation of supporting beams under load shall not exceed the serviceability criteria.

Limiting deflection values shall be agreed with the specifier on a project by project basis, taking into account the specific requirements of the installation.

In the absence of any specific requirements, the limiting deformation values given in Table 13 should be used in the location of the fork tips.

Where beam spans are effectively continuous over two or three bays, both sagging and hogging beam deformations shall be taken into account (see Annex D).

**Table 13 — Maximum deformation of supporting beams under load in the area of the fork tips (mm)**

Beam type	Class 100 mm		Class 200 mm	
	c <sup>c</sup>	d <sup>b</sup>	c <sup>c</sup>	d <sup>b</sup>
Normal beam	L/300 <sup>a</sup> Maximum 10	L/300 <sup>a</sup> Maximum 7	L/200 <sup>a</sup> Maximum 15	L/200 <sup>a</sup> Maximum 9
Cantilever beam	L/100 <sup>a</sup> Maximum 12	L/100 <sup>a</sup> Maximum 8	L/100 <sup>a</sup> Maximum 15	L/100 <sup>a</sup> Maximum 10

a L is the beam span (centreline to centreline of upright, or cantilever length from centreline of upright).  
 b Hogging  
 c Sagging

**7.3.3 Top guide rail deformations**

**7.3.3.1 Y axis deflections**

The vertical top guide rail deformations are shown in Figure 23. The vertical movement of the top guide rail with respect to the system datum plane shall not exceed the limitation set by the specifier or crane supplier.

NOTE The effects of loads applied to the racking and roof loads should be taken into account in this calculation.

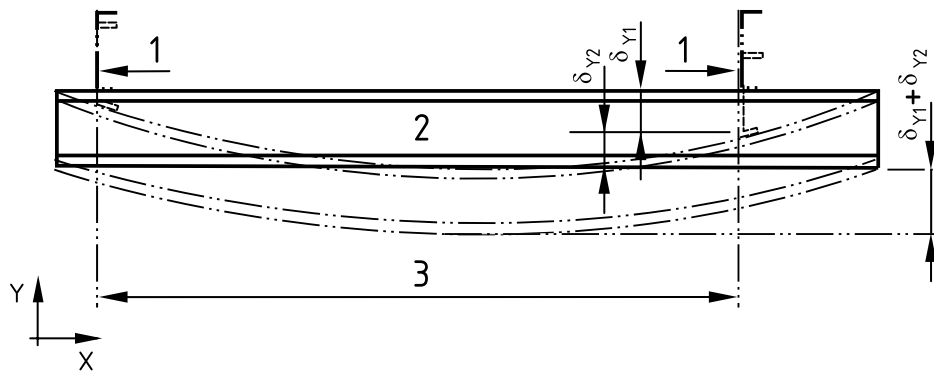

**Key**

- 1 top tie beams
- 2 top guide rail
- 3 span of the guide rail
- $\delta_{y1}$  deflection of the portal beam over the aisle span including upright compression
- $\delta_{y2}$  deflection of the top guide rail between supports
- $\delta_{y1} + \delta_{y2}$  total vertical guide rail movement at mid span due to gravity loads

**Figure 23 — Vertical top guide rail deformations**

### 7.3.3.2 Z axis deflections

The lateral top guide rail deformations are shown in Figure 24. The lateral deflection of the top guide rail with respect to guide rail support positions shall not exceed the deflection limitation set by the specifier or crane supplier.

NOTE 1 This deflection is calculated at the position of the guide rollers and may be exceeded elsewhere on the guide rail.

NOTE 2 The line of action of the crane guide wheel load in the Z direction is generally eccentric to the lateral support of the top ties; therefore the guide rail may rotate about the X axis. The guide wheel loads also cause bending of the web of the guide rail and rotation of the guide rail about its longitudinal X axis. This should be taken into account in the calculation of the Y and Z deflections in 7.3.3.

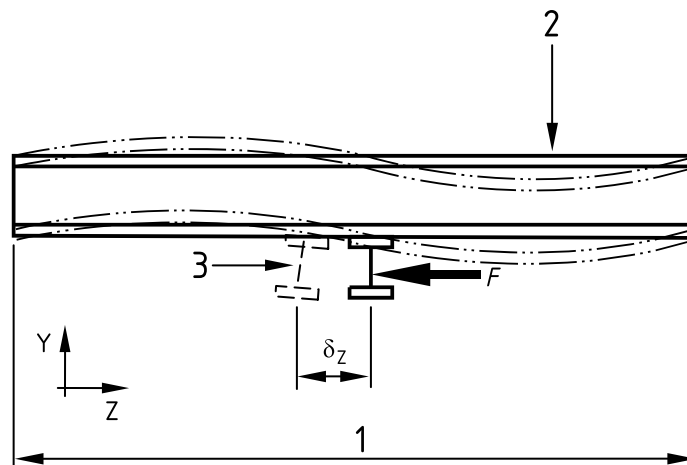

#### Key

- 1 aisle span
- 2 top tie beam
- 3 upper guide rail
- F horizontal force from the guide rollers measured at mid span between the top tie beams
- $\delta_z$  maximum lateral deflection of the crane rail due to deformation of the top tie beam and crane rail resulting from horizontal force from the guide rollers

**Figure 24 — Lateral top guide rail deformations**

### 7.3.4 Frame deformations in the X and Z directions

The maximum frame deformations based on the serviceability limit state (load factor  $\gamma = 1,0$ ) shall be as stated in Table 14 and shall be calculated to include for the effects of one crane force only. The calculation of the deformations shall be carried out using prEN 15512 and other relevant European Standards.

NOTE The initial out of plumb of the frames when first erected increases under gravity loads, crane forces and wind loads and does not completely return to the original installed tolerance.

**Table 14 — Frame deformations based on the serviceability limit state (load factor  $\gamma = 1,0$ )**

Rack height m	Z Sway mm Crane control type A B C or D	X Sway mm Using Euro. Pool pallets 800 x 1200 Type A or D	X Sway mm Using Euro. Pool pallets 800 x 1200 Type B or C	X Sway mm Using Pool pallets 1000 x 1200 Type A B C or D
15	15	12 <sup>a</sup>	10	12
20	20	16 <sup>a</sup>	10	16
25	25	20 <sup>a</sup>	10	20
30	30	20 <sup>a</sup>	10	24
35	35	20 <sup>a</sup>	10	28
40	40	20 <sup>a</sup>	10	32

a These sway values for type D are maximum allowable values based on 165 x 60 telescopic forks. The values may be increased by the specifier or crane supplier using project specific telescopic fork dimensions.

Description of stacker crane control types A, B, C and D:

- A: manual control;
- B: partially or fully automatic control for co-ordinate positioning system;
- C: partially or fully automatic control for co-ordinate positioning and additional compartment precision positioning (Y direction only);
- D: partially or fully automatic control for co-ordinate positioning and additional compartment precision positioning (X and Y directions).

### 7.3.5 Frame deformations in the X and Z directions for clad rack buildings and wind loads

The wind load deformation of the rack structure in the Z direction is shown in Figure 25. The deformation of the racking structure shall be calculated using a wind speed equal to 70 % of the value stated in the relevant national or European Standard (EN) unless specified otherwise in the project design specification.

NOTE This requirement applies to the functionality of the system only and not to any other requirements for stiffness. This means that the wind loads applied to the structure are different for the strength and deflection calculation.

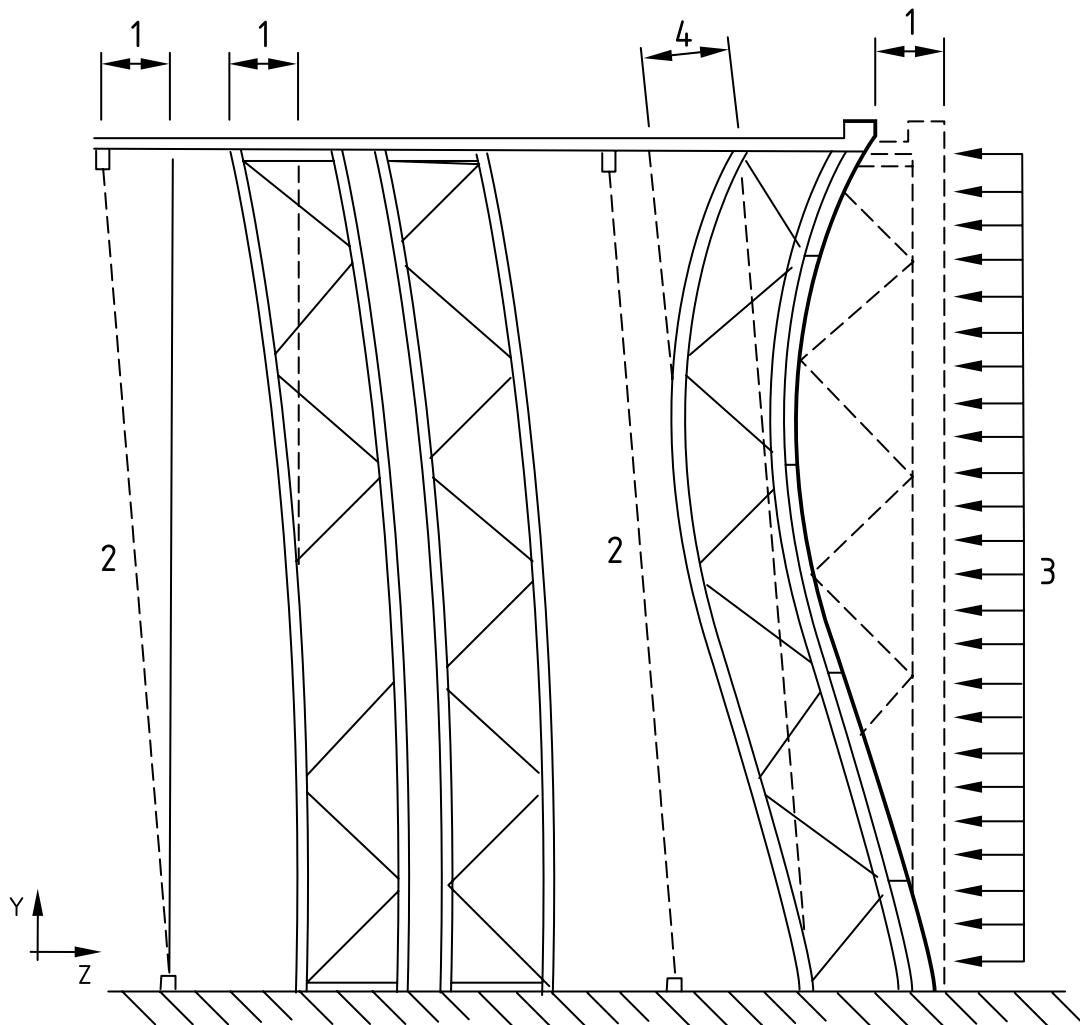

**Key**

- 1 frame and mast deflection
- 2 crane mast inclination
- 3 wind
- 4 edge frame deflection (measured from a straight line between the bottom and top of the upright)

**Figure 25 — Wind load deformation of the rack structure in the Z direction**

Unless specified otherwise in the project design specification, the following limiting values for deflections '1' and '4' should be used:

- '1' should be less than the values for Z sway given in Table 14;
- '4' should be less than 15 mm;

if deformations exceed the limiting values the rack designer shall provide the specifier and or crane manufacturer with the calculated deflection values.

**NOTE** Deflection limits, other than those given above, may be acceptable depending upon the type of unit load to be stored and the load handling techniques adopted.

### **7.3.6 Elastic shortening of uprights**

The Y axis displacement of any beam level depends upon the accumulation of compression strain in the individual upright lengths between the beam levels below the level being considered and shall be taken into account by the specifier or crane supplier when considering the height selection system.

These values shall be provided by the rack supplier.

### **7.4 Clearances for unit loads and crane handling equipment**

Specific project defined clearances are to be used and it is the responsibility of the specifier to ensure that the clearances are acceptable in accordance with the overall system requirements. Tolerances and deformations of the size of the unit load to be stored shall be specified by the specifier or user (see Annex G).

Aisle clearances are the clearances between the outer most edge of the crane handling equipment and the outer-most edge of the rack structure or the load.

### **7.5 Safety backstop deformations**

#### **7.5.1 Deformations**

The horizontal deformation of the safety backstop shall be specified by the crane supplier or specifier and limited to ensure safe support of the unit load on the structure (see prEN 15629).

#### **7.5.2 Clearances**

The clearance from the nominal unit load to the safety backstop shall be specified by the crane supplier.

## **8 Warehouse tolerances and deformations**

With regard to warehouse tolerances and deformations refer to prEN 15629.



## Annex A (informative)

### Adjustable pallet racking components

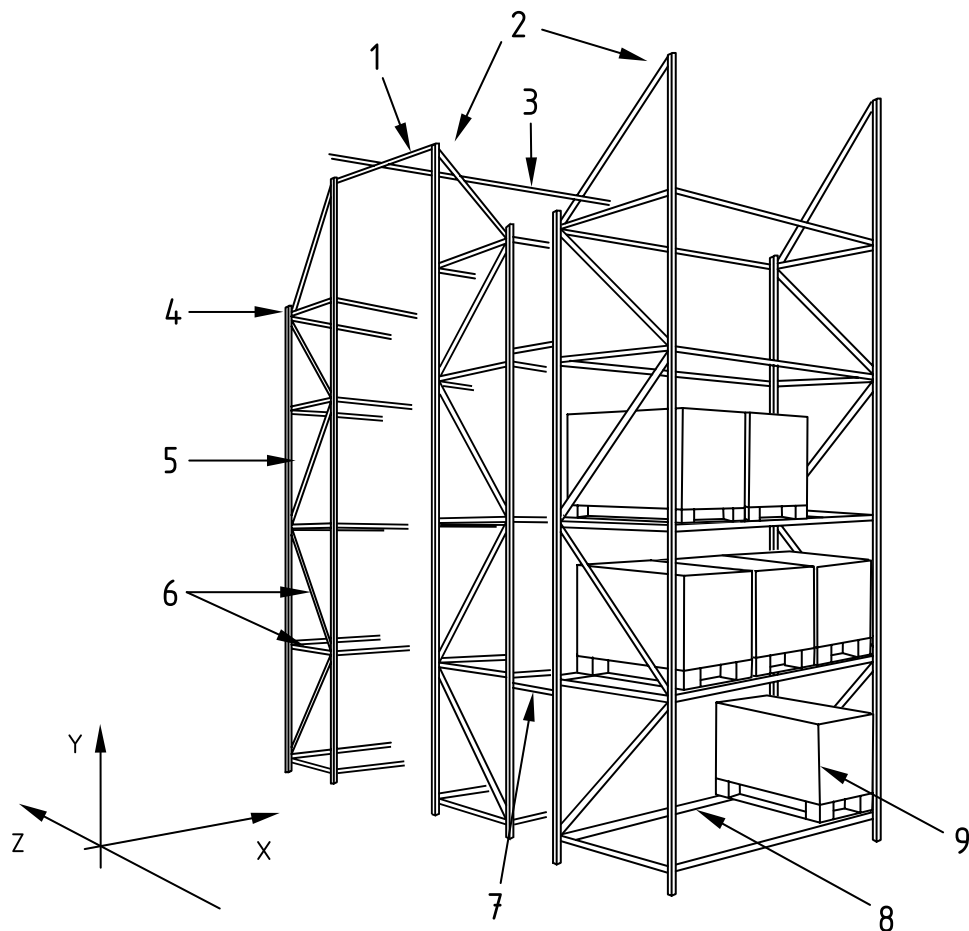

#### Key

- 1 top tie beam
- 2 double entry run
- 3 top guide rail
- 4 frame upright
- 5 single entry run
- 6 frame bracing
- 7 run spacer
- 8 beam
- 9 unit load

**Figure A.1 — Racking components**

Adjustable 'single deep' pallet racking or APR (see Figure A.1) is the most common type of pallet racking in use. Normally APR is used without top tie beams and top guide rails except for crane racking.

Adjustable pallet racking usually consists of two major components, upright frames and beams.

Upright frames are assembled using pairs of continuously perforated uprights connected by bracing members with bolted, riveted or welded joints.

Upright frames are interconnected by beams in pairs to form a row of bays. Pairs of beams are spaced vertically in each bay at a number of levels to provide locations for the pallets or unit loads. Each pair of beams at each level can carry one, two or more unit loads depending upon length and strength.

The connection between beams and uprights is normally made using a hooked connector bracket that engages in the upright perforations which enable the beams to be adjusted vertically to accommodate unit loads of various heights. Some makes of APR use bolted instead of hooked connectors.

Beams are increased in strength and stiffness by increasing the depth and/or width of section and/or the thickness of steel or its quality. Upright sections are similarly varied in strength.

The strength, stiffness and stability of racking in the front to back (cross aisle) Z direction are provided by the upright frames and their connections to the concrete floor slab. In the left to right (down aisle) X direction the strength, stiffness stability is provided in "unbraced" racking by the interaction of upright frames and beams through their hooked (or otherwise) connections together with base plates and fixings to concrete floor slabs.

APR installations are usually constructed with a one pallet deep run of racking on each side of the operating aisle. If the racks can only be accessed from one side only by the truck or crane then this is called a single entry (SE) run. If the racks can be accessed from both sides then this is called a double entry (DE) run. DE runs usually occur between parallel truck or crane aisles.

Runs of racking may have their strength, stiffness and stability increased by the provision of spine and plan bracing. Spine bracing may be placed at the back of a single entry rack or at the centre of back to back double entry racks. Plan bracing is provided between front and back beams to give support to the front uprights.

A top tie beam is provided in the cross aisle, Z, direction where it is required by the handling equipment or for other structural reasons. The top tie can be used to support aisle equipment, for example, lighting, top guide rail, etc.

## **Annex B** (informative)

### **General safety philosophy**

#### **B.1 General**

The safety philosophy in the design of storage equipment is based on the following assumptions:

- a) the use of the storage system is in accordance with the specification prepared by the specifier (see prEN 15629);
- b) the workplace environment is maintained in a good condition (good housekeeping);
- c) loads are secure and stable;
- d) pallets and other load handling accessories are used within their design limitation;
- e) the consideration of the operational interface between racking and MHE resulting in the clearances, complies with this document;
- f) mechanical handling equipment is correctly serviced and maintained by the mechanical handling equipment supplier;
- g) forklift truck drivers are skilled, and trained for the work environment;
- h) the working environment is identified as a 'standard' risk environment by the specifier;
- i) the floor tolerances as specified in this European Standard are appropriate to the operations taking place;
- j) a person responsible for safety (PRS) is appointed as recommended in prEN 15635;
- k) an inspection regime as recommended in prEN 15635 is in place;
- l) a maintenance regime as recommended in prEN 15635 is in place.

If any of these factors are not realised in practice then there is an increased frequency of accidents and magnitude of damage to the racking, etc. This results in an increased risk which will lead to a need for other preventative or remedial actions to take place to maintain a safe working environment. Such provisions may include greater clearances, reduction in throughput, protection to the racking, etc., shown diagrammatically in Figure B.1.

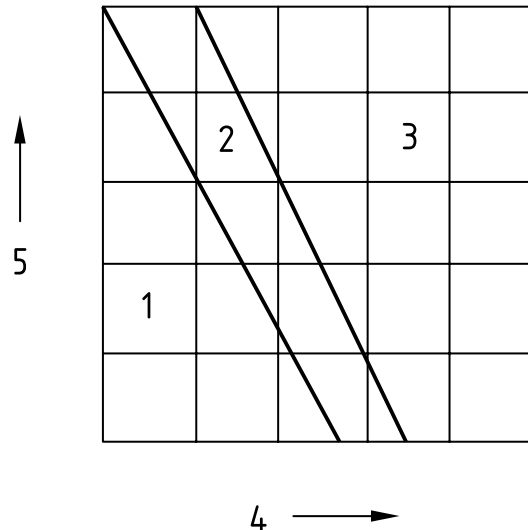

**Key**

- 1 zone of low risk operation
- 2 area of medium risk operation
- 3 area of high risk operation
- 4 increasing magnitude of damage
- 5 increasing frequency of accidents

**Figure B.1 — Risk**

## B.2 Wide and narrow aisle width manoeuvring clearance

The aisle clearances are based on the requirement that in those situations where the lowest unit load is supported on the concrete floor, the pallet or its load shall be placed in order not to encroach on the operating width of the aisle.

The manoeuvring clearance is the dimension by which the aisle width, based on the dimensions and the manoeuvring properties of the industrial truck and the load, is increased. A value of 200 mm is commonly used for 90° stacking.

Where the lowest unit load in a rack is supported on the floor, a permanent line drawn down each side of each aisle to mark this position may help to control the position of the unit load.

## B.3 Intrusive stacking

Intrusive stacking is outside the scope of this document for the following reasons:

- a) there is a greater risk of impact damage being sustained by the rack structure when entering or retrieving a unit load;
- b) larger bay clearances are required;
- c) there is an increased risk of the truck swaying on uneven floors and impacting the racks or unit loads when the aisle clearances are reduced below the limits specified;
- d) most trucks are not designed to turn with the load elevated, and therefore there is a risk of the truck becoming unstable and overturning.

## **B.4 Environments with additional risk**

In higher risk environments (as defined by the specifier), larger clearances may be required to maintain safe working conditions.

For example in a wide or narrow aisle installation the minimum aisle clearance may need to be increased from 200 mm to 350 mm or more for safety due to the following factors:

- a) load units not rigid;
- b) large load dimensions that make precise driving approaches more difficult;
- c) fast throughput.

## **B.5 Truck requirements**

A typical example of the aisle width requirements for adequate 90° stacking truck manoeuvrability is shown in Figure B.2.

**NOTE** For minimum aisle widths see FEM Industrial Trucks Technical Note FEM 4.005. The 90° truck turning dimensions are dependent on the design of the lift truck and the lift truck manufacturer should be consulted for accurate aisle width dimensions.

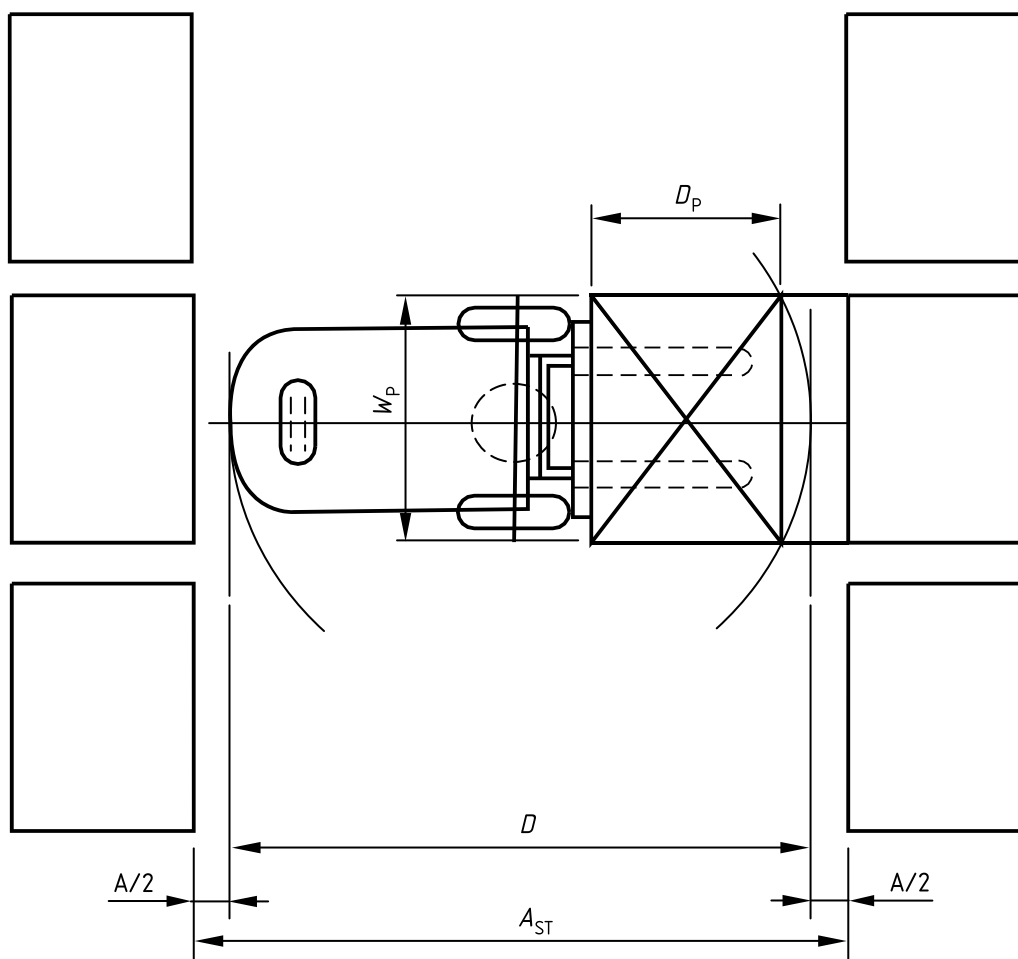

**Key**

- A** manoeuvring clearance
- $D_p$**  depth of unit load and pallet
- D** 90° turning width of truck and load
- $A_{ST}$**  minimum clear aisle width, between unit load faces or structure at any level
- $W_p$**  width of unit load and pallet

**Figure B.2 — Aisle width dimension**

NOTE The nominal position of the unit load on the floor may be indicated by floor marking.

## B.6 Floor tolerances and deformations

### B.6.1 General

Floor tolerances and deformations are limited in order that the storage system of racking and MHE can operate safely. Trucks are used either in free movement or in defined movement. Free movement is found in wide and narrow aisles as well as in open storage. Defined movement is generally only found in very narrow aisle (VNA) installations.

In free movement areas, tolerances are controlled over 3 m to ensure adequate interface tolerances between racking and MHE. It is assumed that MHE always transport loads at low level when moving.

In defined movement areas, tolerances are controlled over distances that are related to the MHE dimensions. It is assumed that MHE always carry loads at both high and low level when moving.

### **B.6.2 Sloping floors**

Racking erected on sloping floors follows the slope unless corrected by shimming or grouting the upright base plates. If erected to follow the floor slope, the racking inclines to the vertical at the same angle as the floor slope.

Floors are assumed not to be sloping unless specified otherwise.

### **B.6.3 MHE lean**

Figure B.3 shows the static lean of a VNA truck; the lean can be significantly increased due to dynamic driving effects and shall be considered by the specifier and client when considering the safe functioning of the overall system.

Dimensions in millimetres

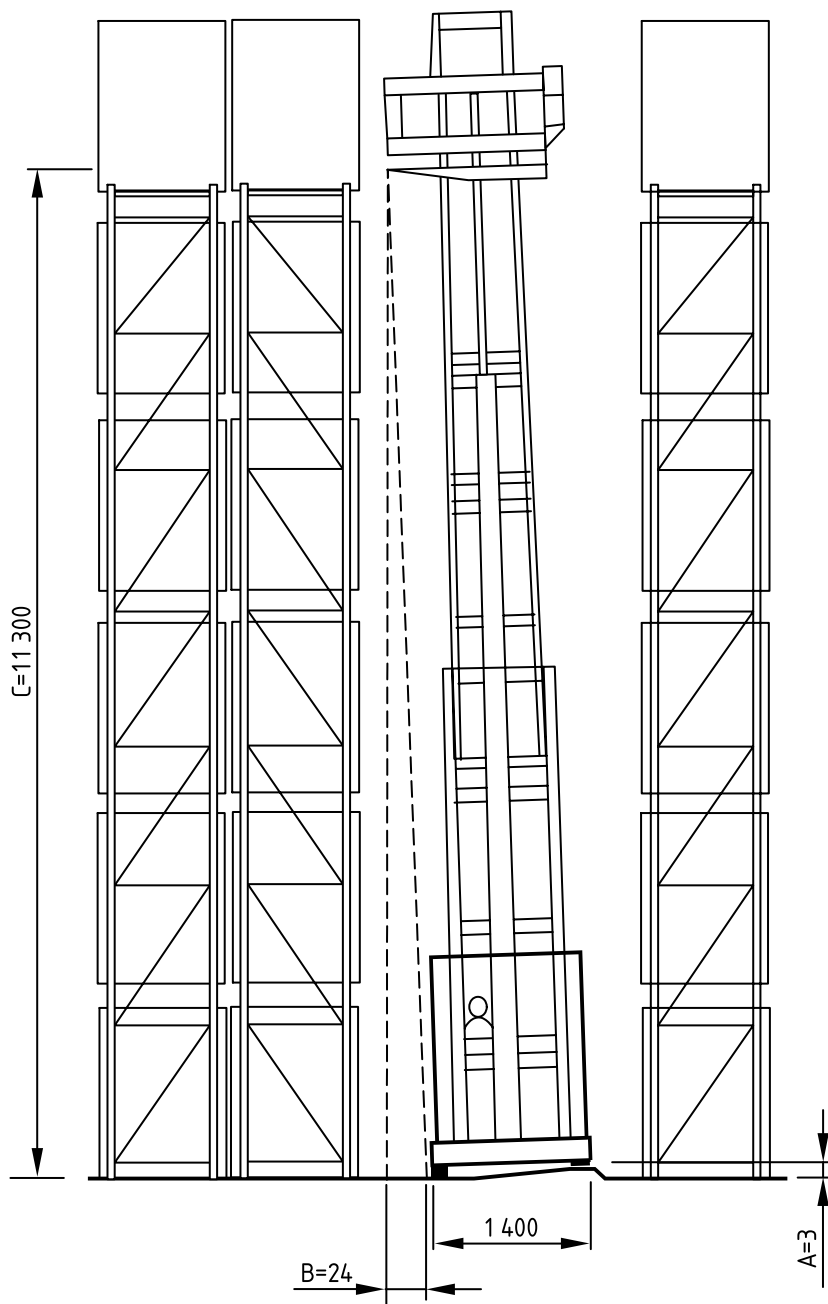

**Key**

- A floor unevenness due to floor tolerances and deformations
- B static lean
- C lift height

**Figure B.3 — Relationship between flatness and static lean of truck mast (mast assumed rigid)**



## **Annex C** (informative)

### **Racking measurement surveys**

#### **C.1 General**

The measurement survey will usually measure the installation tolerances and clearances before the racking is loaded. The tolerances stated in this European Standard may not be applicable after the racking has been loaded.

Measurement surveys are conducted when required by individual contracts.

#### **C.2 Agreed grid lines and datum's**

Before erection of an installation commences, a basis for the measurement survey grid lines and datum's should be agreed between the parties.

#### **C.3 Principal grid lines and datum's**

The main survey grid lines and datum point are:

- the System X datum lines parallel to the rack aisles;
- the System Y datum point;
- the System Z datum line perpendicular to the rack aisles.

#### **C.4 Measurement survey reports**

##### **C.4.1 General**

The survey should be based on the grid layout of the racks in the X Z plane and according to beam level in Y direction. Surveys should be recorded and reported.

If appropriate, ambient conditions such as temperature and wind speed should also be recorded.

##### **C.4.2 Measuring conditions**

If the environmental conditions can affect the measurements then an appropriate correction factor should be used.

## **Annex D** (informative)

### **Effects of beam hogging and sagging deformations on clearances**

#### **D.1 Effects of beam hogging and sagging deformations on clearances $X_3$ , $X_4$ and $Y_1$ , $Y_2$ and $Y_3$ for non cantilevered beams**

The beam deflection will reduce the nominal  $X_4$  clearance; this is generally not an issue for unit loads under 3 m height. In extreme situations the slope of the load should be calculated and the clearances increased accordingly.

Unit load and rack X and Y clearances are shown in Figure D.1.  $Y_6$  is determined by:

- vertical level tolerance between aisle-sided and back beam;
- MHE dynamics during depositing or picking;
- placement operation.

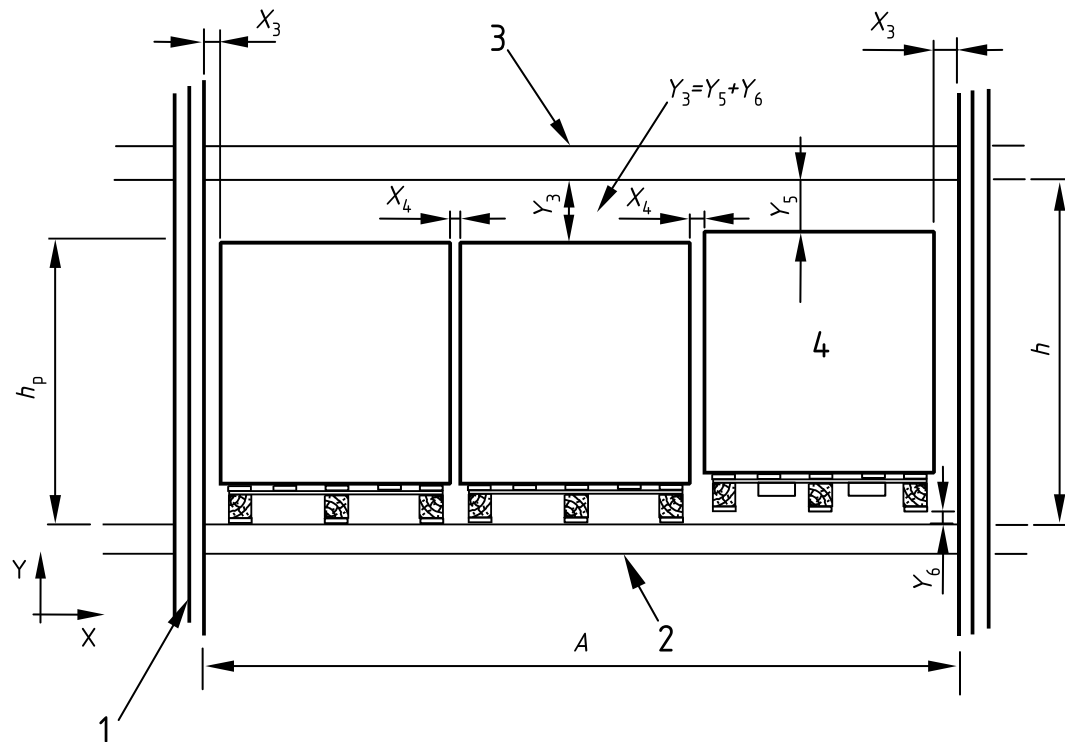

**Key**

- 1 upright
- 2 beams
- 3 beams shown without beam deflections
- 4 unit load on raised forks
- $h_p$  design height of unit load and pallet
- $h$  height of compartment
- $A$  beam clear entry
- $X_3$  clearance between upright and unit load
- $X_4$  clearance between unit loads
- $Y_3$  clearance between top of unit load and underside of beam
- $Y_5$  clearance between top of unit load and underside of beam when depositing unit load
- $Y_6$  clearance between bottom of pallet and top of beam when depositing unit load
- $\alpha_3, \alpha_4$  angles of load in compartments 3 and 4 respectively

**Figure D.1 — Unit load and rack X and Y clearances**

Mechanical handling equipment fork and unit load clearances over the rack beam are shown in Figure D.2. A small pallet has a smaller aperture and the associated fork clearance shall be considered allowing for the smaller aperture.

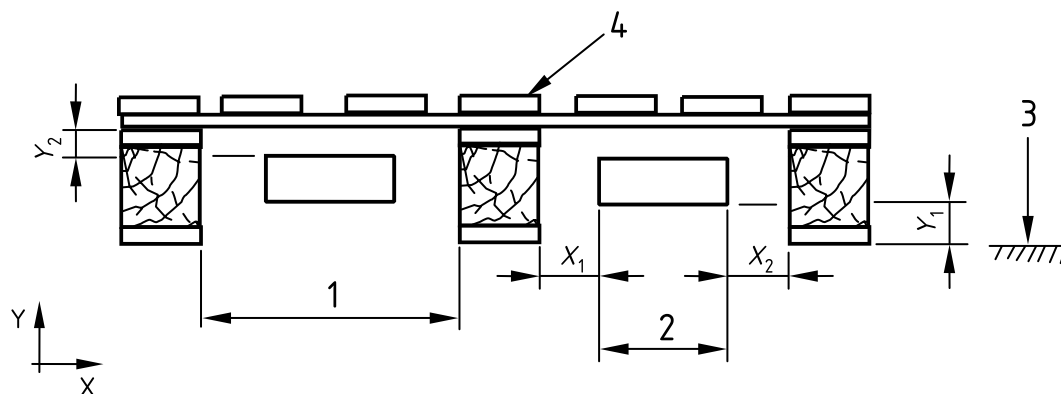

**Key**

- 1 fork entry aperture
- 2 MHE fork width
- 3 top of beam
- 4 single deck pallet
- $Y_1$  fork clearance over beam
- $Y_2$  fork clearance under pallet
- $X_1$  and  $X_2$  horizontal fork clearance to pallet

**Figure D.2 — Mechanical handling equipment fork and unit load clearances over the rack beam**

The effects of beam hogging and sagging deformation on  $X_3$ ,  $X_4$ , and  $Y_1$ ,  $Y_2$  and  $Y_3$  are shown in Figures D.3 and D.4.

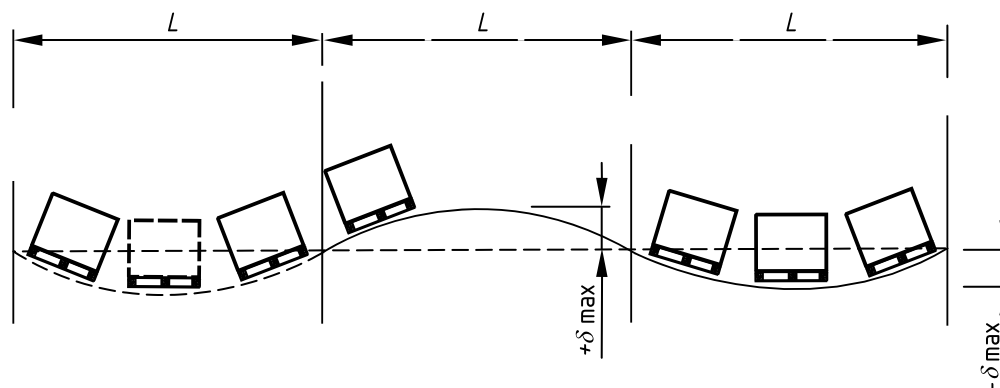

**Key**

- $L$  distance between upright centres
- $+\delta_{max}$  hogging deformation
- $-\delta_{max}$  sagging deformation

**Figure D.3 — The effects on clearances of beam deformations**

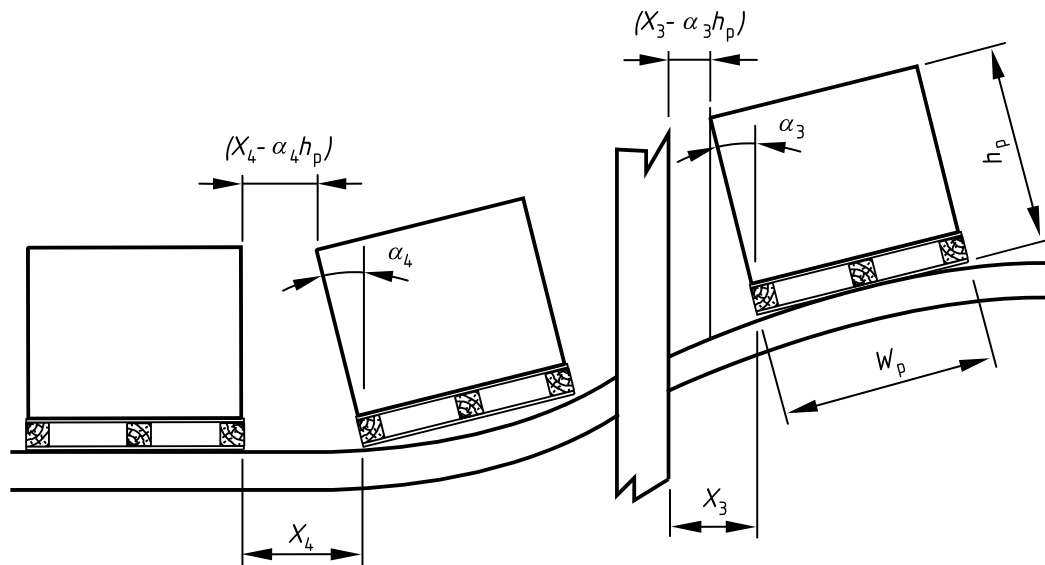

**Key**

- $h_p$  height of unit load and pallet
- $w_p$  width of unit load and pallet
- $\alpha$  angle of load

**Figure D.4 — Enlarged detail of unit load displacements**

The displacement  $\alpha_4 \cdot h_p$  needs to be taken into account twice in a two unit load situation.

The additional clearance  $\alpha \cdot h_p$  to be used in the calculation of the total clearances for  $X_3$  and  $X_4$  depends upon the relative vertical deflections of the unit load support points along the beam that effect the verticality of the unit load. The way in which this can be accurately calculated is shown in Figure D.4. Similar procedures can be followed for various worst case combinations of pattern loading for any number of unit loads on a pair of beams and any degree of continuity of beams by rigid or semi-rigid connections to the rack uprights.

## D.2 Effects of beam hogging and sagging deformations on $X_3$ , $X_4$ and $Y_1$ , $Y_2$ and $Y_3$ for cantilevered beams (P and D stations)

The effects of continuous beam cantilever deflections on clearances are illustrated in Figure D.5.

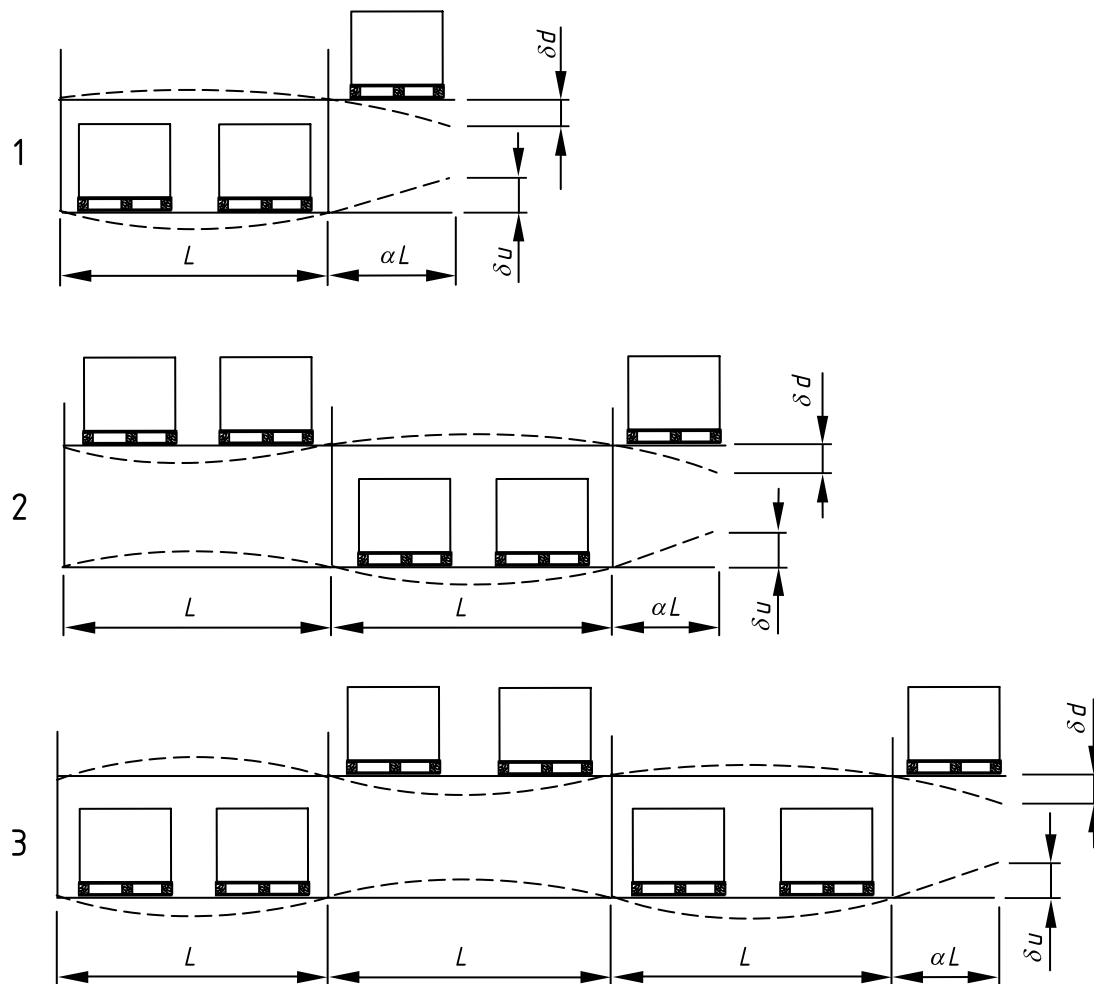

### Key

- 1 one bay
- 2 two bays
- 3 three bays
- $L$  distance between upright centres
- $\delta_u$  hogging deformation
- $\delta_d$  sagging deformation
- $\alpha L$  distance between upright centre and end of cantilever

Figure D.5 — The effects on clearances of cantilever beam deformations

## Annex E (informative)

### Additional information for determining dimensions and clearances in the depth of the rack (Z direction)

#### E.1 Placement tolerances in the depth of the rack

The dimensions and clearances in the depth of the rack (Z direction) are shown in Figure E.1. Ideally a pallet should be placed concentrically on a pair of beams in a pallet rack compartment. Placement tolerances in the Z direction need to be taken into account when determining the unit load clearances.

The fork lift truck driver takes his placement bearings for the pallet from the front face of the aisle beam when placing the pallet. This means that placement tolerances increase with larger values of  $Z_{2a}$  because a greater overhang permits greater inaccuracy.

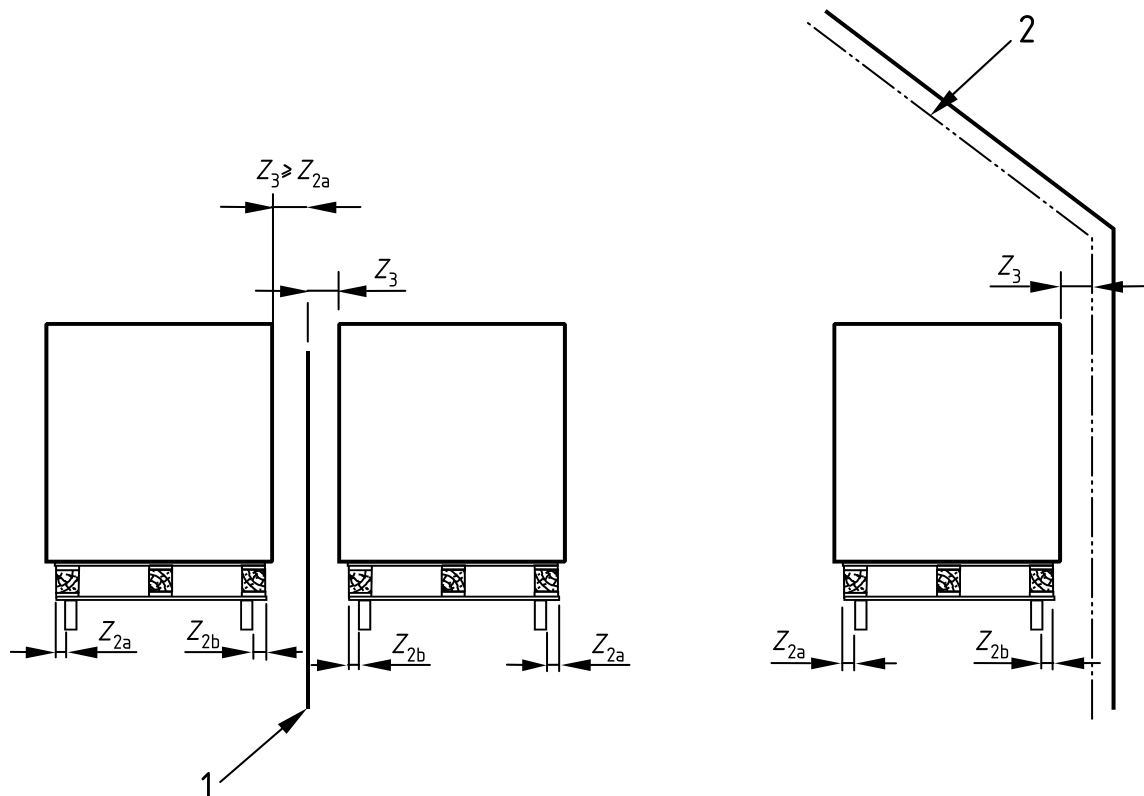

#### Key

- 1 obstruction in its worst position including building movement as appropriate
- 2 obstruction in its worst position including building movement as appropriate
- $Z_{2a}$ ,  $Z_{2b}$  overhang of the pallet from the front and rear beams respectively
- $Z_3$  clearance between unit load and obstruction

Figure E.1 — Clearance to building obstruction due to placement tolerance (Z direction)

The values can be different from the values given in 5.4.3 and 6.4.3.

For instance:

- $Z_{2a}$  is greater than or equal to 50 mm and less than or equal to 100 mm;
- $Z_{2b}$  is greater than or equal to 50 mm and less than or equal to 100 mm;
- $Z_{2b}$  is equal to  $Z_{2a}$ .

The minimum values are to ensure sufficient pallet support on the beams. However, when secondary supports are provided between the beams  $Z_{2a}$  and  $Z_{2b}$  may be less than zero however the distance between back to back unit loads should still be a minimum of 100 mm and  $Z_3$  should still be a minimum of 50 mm.

## E.2 Larger values of $Z_{2a}$ and $Z_{2b}$

Larger values of  $Z_{2a}$  and  $Z_{2b}$  than 50 mm can also be used, however, in such cases the following should be considered:

- a) a larger clearance between back to back unit loads ( $Z_1$ ) and to any obstruction ( $Z_3$ ) should be provided because placement tolerances can increase with larger values of  $Z_{2a}$ ;
- b) with larger placement variations, the difference between the loads supported by the two beams increases and should be taken into account in the design;
- c) the bottom deck boards of the pallet may be incorrectly loaded.

Bottom board deformation due to incorrect pallet placement is shown in Figure E.2.

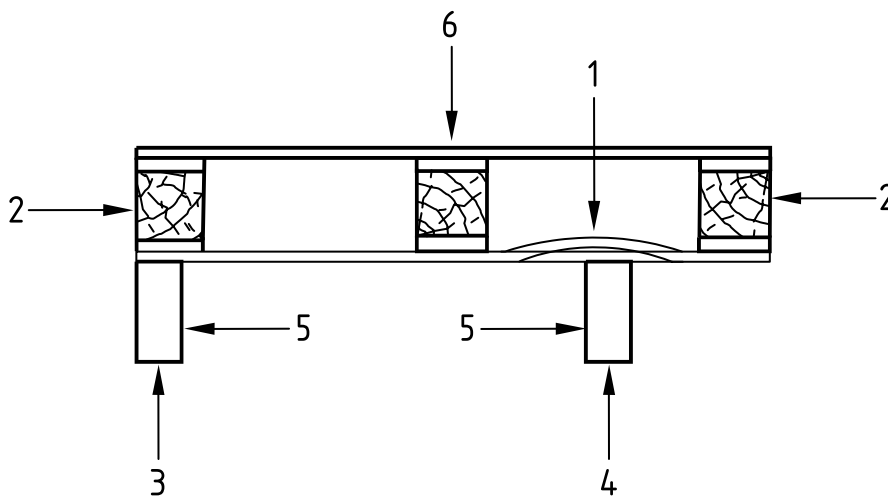

### Key

- 1 deformed bottom board
- 2 pallet block
- 3 smaller beam load
- 4 larger beam load
- 5 beams
- 6 load

Figure E.2 — Bottom board deformation due to incorrect pallet placement



Larger values of  $Z_{2a}$  and  $Z_{2b}$  than 50 mm (e.g. 75 mm) are normally only considered in order to:

- 1) ensure safe support conditions for a VNA truck with fixed stroke (increased Z depositing tolerance with increased height, see Annex F);
- 2) reduce the deflection of the pallet between the beams, as may be the case with stacker cranes or VNA trucks fitted with telescopic forks which have a height of 40 mm to 60 mm, depending on the pallet type, weight and depth.

However such types of pallet handling equipment generally have good control of the pallet positioning:

- 3) the unit loads are positioned with a fixed stroke (some VNA trucks can sometimes vary the stroke);
- 4) the position of the equipment with respect to the racking is fixed;
- 5) the pallets used in association with stacker cranes should be consistent high quality; otherwise the crane and/or the pallet handling (conveyor) system would be unreliable.

Because of 3) and 4) the placement tolerance in the depth (Z direction) is much smaller compared to counter-balanced or to reach truck situations.

## Annex F (informative)

### Additional information for very narrow aisle trucks in adjustable pallet racking

#### F.1 General

The clearances given in this European Standard are considered to be minimum values. The specifier is responsible for determining the clearances using the tolerances as stated in this European Standard. If greater clearances are required they should be specified by the truck supplier or specifier.

Some factors which need to be considered for the overall safe operation of the system are given in the following clauses.

#### F.2 Considerations for the Z direction

When using trucks with a fixed fork stroke, the location of the unit load, when deposited, depends upon a number of factors including:

- a) the level of the floor across the aisle causing the truck to lean;
- b) the location of the unit load on the truck;
- c) the (+Z) deformation of the truck mast and lateral deflection due to the load on the cantilevered forks;
- d) the differential wear and deflection of the truck tyres due to the load and fork eccentricity which is also causing a sway in the +Z direction;
- e) the looseness in the truck mechanism, which increases with wear;
- f) the accuracy of the location devices in the P and D station;
- g) the tolerance of the guidance system.

When using trucks without a fixed stroke the location of the unit load, when deposited, depends upon a number of factors including:

- 1) the verticality of the rack frames in the Z direction;
- 2) the manual placement tolerance in the Z direction; in the cross aisle direction,  $Z_{2a}$  (see 6.4.3 and Annex E); in the down aisle direction the tolerance depends on the instruction to the operator, e.g. 25 mm.

The aisle clearance shall include the following factors:

- the location of the unit load in the rack;
- the level of the floor across the aisle causing the truck to lean;
- the location of the unit load on the truck;
- the static and dynamic mast sway of the truck;

- the differential wear and deflection of the truck tyres;
- looseness in the truck mechanism, which increases with wear;
- the tolerance of the guidance system;
- the unit load tolerances.

### **F.3 Considerations in the Y direction**

The interaction between rack, truck and unit load is controlled in this direction by the fork aperture available. This can be either:

- a) the dimension between the top deck and bottom boards of a pallet with bottom boards; or
- b) the dimension from the top of the rack beam to the underside of the top deck boards of the pallet; or
- c) the dimension from the top of the rack beam to the underside of the bottom boards of a pallet when it is supported on fork entry bars.

Generally, very narrow aisle trucks are fitted with fixed forks, but there are some hybrid truck designs with telescopic forks.

A fixed fork is about 40 mm deep whereas a telescopic fork is about 60 mm to 70 mm deep, therefore a fixed fork requires a smaller vertical opening than a telescopic fork.

### **F.4 Height selection device**

These devices are mostly used on class 300B VNA trucks. Their purpose is to position the elevated fork arms automatically at a predetermined height for unit load storage or retrieval operations for each load level of the racking.

If a height selection device is used, the specifier or truck supplier should determine whether the tolerance limit of the beam levels in the Y direction and the beam deflection limits are acceptable.

### **F.5 Pick up and deposit (P and D) stations**

For very narrow aisle installations, P and D stations should be used and should be fitted with pallet locators which position the pallet, in the X direction, in relation to the truck stop position for the pick up on the input cycle and, in the Z direction, in relation to the nominal position of the pallet on the rack beams.

## **Annex G** (informative)

### **Consideration of tolerances and deformations in determining clearances**

#### **G.1 General**

The reliability of a system is usually ensured by the system designer calculating the "worst case" summation of all the parameters that affect the safe interaction of the handling equipment, unit load and racking. These are considered in addition with any other equipment, for example a sprinkler system, which may need to be taken into account.

The "worst case" calculation means that if all agreed tolerances and deformations are at their maximum value and are all affecting the parameter concerned at the same time in the most unfavourable direction, the clearances between moving and stationary parts to the system are sufficient to avoid collisions.

The statistical probability that the worst case could arise in reality is relatively small because a relatively large number of variables is involved. Therefore, storage systems can function entirely satisfactorily even when one or two tolerances and deformations are marginally larger than specified.

The values stated in this document may be amended for technical or economic reasons, if the functionality and safe operation of the whole system can be guaranteed.

NOTE For calculating clearances with storage and retrieval machines in high-bay warehouses see FEM 9.831

#### **G.2 Storage systems other than single deep adjustable pallet racking**

In racking systems that are different from single deep adjustable pallet rack arrangements, such as double deep racks or cantilever beamless racks, these recommendations should be reviewed and adjusted to meet the safe practical operational requirements of the storage system being designed.

NOTE It is recommended to refer to FEM 9.831 for other types of pallet racking serviced by cranes.

## Annex H (informative)

### Top guide rail tolerance recommendations

The manufacturing tolerances of the top rail section are determined by the manufacturing (rolling) process and cannot be adjusted thereafter. The following steps should be taken to minimise the assembly and erection tolerances of the top rail section:

- to refer to EN 10034;
- to refer to EN 10210-2;
- to refer to EN 10056-2;
- to purchase all of the material for the project from one production batch, which minimises the chances of large tolerance differences between the lengths of material supplied;
- to connect the rail lengths to the top tie beams taking into account the tolerance direction (see Figure H 1).

It may not be possible in practice to achieve results 1 and 2 simultaneously.

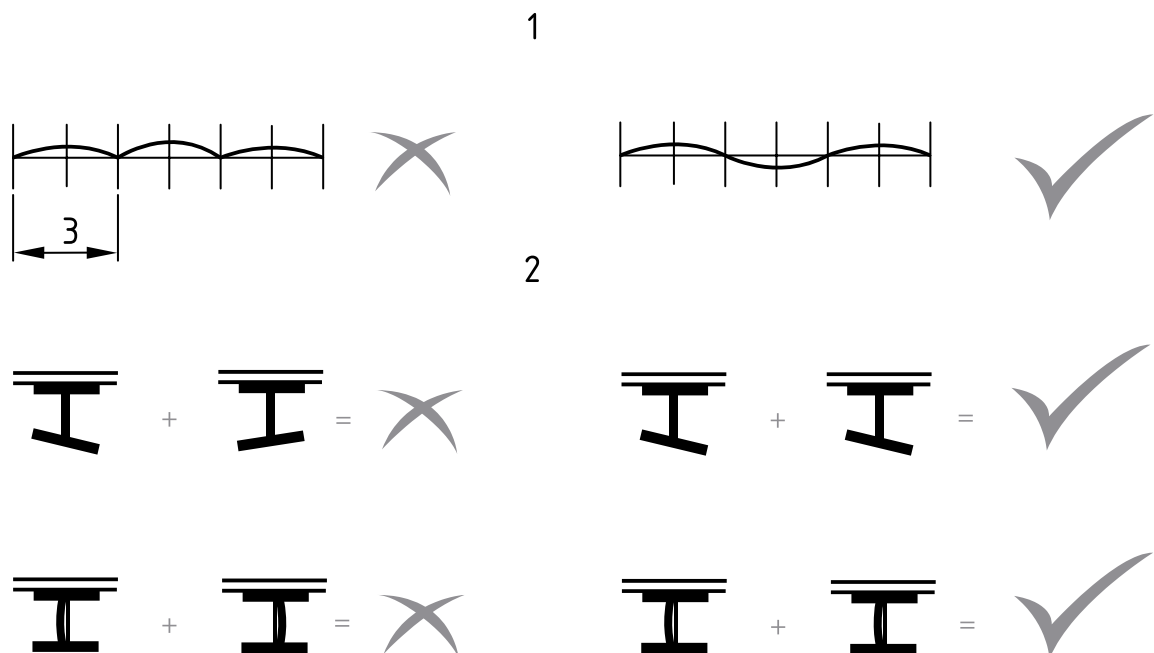

**Key**

- 1 plan view
- 2 sections through rail profiles
- 3 member length, approximately 6 m

**Figure H.1 — A method of allowing for the section tolerances when erecting the top guide rail to the top tie beams**

## Bibliography

- [1] FEM 4.005, *Industrial Trucks – 90 ° stacking aisle width*
- [2] FEM 10.2.06, *The Design of Hand Loaded Static Steel Shelving Systems*
- [3] FEM 10.2.07, *The Design of Drive In and Drive through Pallet Racking*
- [4] FEM 10.2.08, *The Seismic Design of Static Steel Pallet Racking*
- [5] FEM 9.831, *Calculation principles of storage and retrieval machines — Tolerances, deformations and clearances in high-bay warehouses*
- [6] EN 528, *Rail dependent storage and retrieval equipment — Safety*
- [7] EN 1993-1-1, *Eurocode 3: Design of steel structures — Part 1-1: General rules and rules for buildings*
- [8] EN 1993-1-3, *Eurocode 3 — Design of steel structures — Part 1-3: General rules — Supplementary rules for cold-formed members and sheeting*
- [9] EN 10034, *Structural steel I and H sections – Tolerances on shape and dimensions*
- [10] EN 10056-2, *Structural steel equal and unequal leg angles – Part 2: Tolerances on shape and dimensions*
- [11] EN 10210-2, *Hot finished structural hollow sections of non-alloy and fine grain steels — Part 2: Tolerances, dimensions and sectional properties*
- [12] prEN 15635, *Steel static storage systems – The application and maintenance of storage equipment*
- [13] European Council Directive 92/59/EEC, *General product safety*
- [14] European Commission Directive 92/58/EEC, *Minimum requirements for the provision of safety and /or health signs at work*



---

## BSI - British Standards Institution

BSI is the independent national body responsible for preparing British Standards. It presents the UK view on standards in Europe and at the international level. It is incorporated by Royal Charter.

### Revisions

British Standards are updated by amendment or revision. Users of British Standards should make sure that they possess the latest amendments or editions.

It is the constant aim of BSI to improve the quality of our products and services. We would be grateful if anyone finding an inaccuracy or ambiguity while using this British Standard would inform the Secretary of the technical committee responsible, the identity of which can be found on the inside front cover. Tel: +44 (0)20 8996 9000. Fax: +44 (0)20 8996 7400.

BSI offers members an individual updating service called PLUS which ensures that subscribers automatically receive the latest editions of standards.

### Buying standards

Orders for all BSI, international and foreign standards publications should be addressed to Customer Services. Tel: +44 (0)20 8996 9001. Fax: +44 (0)20 8996 7001 Email: [orders@bsigroup.com](mailto:orders@bsigroup.com) You may also buy directly using a debit/credit card from the BSI Shop on the Website <http://www.bsigroup.com/shop>

In response to orders for international standards, it is BSI policy to supply the BSI implementation of those that have been published as British Standards, unless otherwise requested.

### Information on standards

BSI provides a wide range of information on national, European and international standards through its Library and its Technical Help to Exporters Service. Various BSI electronic information services are also available which give details on all its products and services. Contact Information Centre. Tel: +44 (0)20 8996 7111 Fax: +44 (0)20 8996 7048 Email: [info@bsigroup.com](mailto:info@bsigroup.com)

Subscribing members of BSI are kept up to date with standards developments and receive substantial discounts on the purchase price of standards. For details of these and other benefits contact Membership Administration. Tel: +44 (0)20 8996 7002 Fax: +44 (0)20 8996 7001 Email: [membership@bsigroup.com](mailto:membership@bsigroup.com)

Information regarding online access to British Standards via British Standards Online can be found at <http://www.bsigroup.com/BSOL>

Further information about BSI is available on the BSI website at <http://www.bsigroup.com>.

### Copyright

Copyright subsists in all BSI publications. BSI also holds the copyright, in the UK, of the publications of the international standardization bodies. Except as permitted under the Copyright, Designs and Patents Act 1988 no extract may be reproduced, stored in a retrieval system or transmitted in any form or by any means – electronic, photocopying, recording or otherwise – without prior written permission from BSI.

This does not preclude the free use, in the course of implementing the standard, of necessary details such as symbols, and size, type or grade designations. If these details are to be used for any other purpose than implementation then the prior written permission of BSI must be obtained.

Details and advice can be obtained from the Copyright and Licensing Manager. Tel: +44 (0)20 8996 7070 Email: [copyright@bsigroup.com](mailto:copyright@bsigroup.com)