

BS EN 15566:2016



BSI Standards Publication

Railway applications — Railway rolling stock — Draw gear and screw coupling

National foreword

This British Standard is the UK implementation of EN 15566:2016. It supersedes BS EN 15566:2009+A1:2010 which is withdrawn.

The UK committee draws users' attention to the distinction between normative and informative elements, as defined in Clause 3 of the CEN/CENELEC Internal Regulations, Part 3.

Normative: Requirements conveying criteria to be fulfilled if compliance with the document is to be claimed and from which no deviation is permitted.

Informative: Information intended to assist the understanding or use of the document. Informative annexes do not contain requirements, except as optional requirements, and are not mandatory. For example, a test method may contain requirements, but there is no need to comply with these requirements to claim compliance with the standard.

The UK loading gauge is much smaller than the gauge in Europe and the maximum axle load is higher at 25.4 tonnes. As a consequence of this, longer thinner wagons are built to maximize the pay load of wagons carrying lower density products.

In order to maximize the volumetric capacity of the wagon body within this overall length 520 mm buffers continue to be used with a head radius of 1 250 mm to cater for the tighter curves found in many UK terminals (for example Oleo OP176GX buffers). As EN 15566 is referenced in the Wagon TSI, any new wagons would have to be built with a 620 mm buffer and 2 750 mm head radius.

This would have three effects:

- 1) The wagon bodies would have to be shorter to allow for the longer buffers within the same 18 300 mm overall length with a corresponding loss of payload of typically 1 tonne on every journey.
- 2) The use of the 2 750 mm head radius would push the drawbar loads over the 250 kN limit when negotiating 70 m curves, which would necessitate lengthening the screw couplings every time the wagons went into tight terminals and tightening them again once they were back on the mainline. This would cause delays to arrivals and departures, add cost and present an additional safety hazard to the shunters.
- 3) If the 520 mm buffer is no longer used for new build wagons, the manufacturers will eventually cease to make them. The vast majority of UK bogie wagons are fitted with these buffers and any new casings required to replace worn ones would then need to be specially made at a vast increase in cost.

Therefore wagons for use exclusively in the UK may continue to use 520 mm projection buffers in EN 15551 and the corresponding UK Draw Hook (to drawing C1-A1-9006711) and Screw Coupling (to drawing F-AO-13970). Drawings may be obtained from Serco Raildata – email: docrequest@serco.com

The UK participation in its preparation was entrusted by Technical Committee RAE/3, Railway Applications - Rolling Stock Products, to Subcommittee RAE/3/-7, Railway applications - Couplers.

A list of organizations represented on this subcommittee can be obtained on request to its secretary.

This publication does not purport to include all the necessary provisions of a contract. Users are responsible for its correct application.

© The British Standards Institution 2016.

Published by BSI Standards Limited 2016

ISBN 978 0 580 74356 6

ICS 45.040; 45.060.01

Compliance with a British Standard cannot confer immunity from legal obligations.

This British Standard was published under the authority of the Standards Policy and Strategy Committee on 31 October 2016.

Amendments/corrigenda issued since publication

Date	Text affected
------	---------------

EUROPEAN STANDARD

EN 15566

NORME EUROPÉENNE

EUROPÄISCHE NORM

September 2016

ICS 45.060.01

Supersedes EN 15566:2009+A1:2010

English Version

Railway applications - Railway rolling stock - Draw gear and screw coupling

Applications ferroviaires - Matériel roulant ferroviaire
- Organes de traction et tendeur d'attelage

Bahnanwendungen - Schienenfahrzeuge -
Zugeinrichtung und Schraubenkupplung

This European Standard was approved by CEN on 8 July 2016.

CEN members are bound to comply with the CEN/CENELEC Internal Regulations which stipulate the conditions for giving this European Standard the status of a national standard without any alteration. Up-to-date lists and bibliographical references concerning such national standards may be obtained on application to the CEN-CENELEC Management Centre or to any CEN member.

This European Standard exists in three official versions (English, French, German). A version in any other language made by translation under the responsibility of a CEN member into its own language and notified to the CEN-CENELEC Management Centre has the same status as the official versions.

CEN members are the national standards bodies of Austria, Belgium, Bulgaria, Croatia, Cyprus, Czech Republic, Denmark, Estonia, Finland, Former Yugoslav Republic of Macedonia, France, Germany, Greece, Hungary, Iceland, Ireland, Italy, Latvia, Lithuania, Luxembourg, Malta, Netherlands, Norway, Poland, Portugal, Romania, Slovakia, Slovenia, Spain, Sweden, Switzerland, Turkey and United Kingdom.



EUROPEAN COMMITTEE FOR STANDARDIZATION
COMITÉ EUROPÉEN DE NORMALISATION
EUROPÄISCHES KOMITEE FÜR NORMUNG

CEN-CENELEC Management Centre: Avenue Marnix 17, B-1000 Brussels

Contents		Page
European foreword		7
Introduction		9
1	Scope	10
2	Normative references	10
3	Terms and definitions	11
4	Requirements for all types of draw gear and screw coupling	13
4.1	Classification and designation.....	13
4.2	Interaction coupling/buffer	13
4.3	Interface dimension for freight wagons.....	14
4.4	Life time	15
5	Draw gear	16
5.1	Draw gear components	16
5.2	Draw hook and drawbar – Requirements	18
6	Screw coupling	18
6.1	General requirements	18
6.2	Screw coupling – Requirements.....	20
7	Elastic device	20
7.1	Characteristics of elastic device.....	20
7.2	Elastic device – Requirements.....	21
Annex A (normative) Dynamic test (fatigue test) procedure		22
A.1	Background	22
A.2	Performance of the test.....	22
A.2.1	Conditioning.....	22
A.2.2	Dynamic test (fatigue test).....	22
A.2.3	Non-destructive tests.....	24
A.2.4	Determination of residual strength.....	24
A.2.5	Macrographic and Micrographic tests.....	24
A.3	Criteria of acceptance	24
Annex B (normative) Draw hook – dimensions		25
Annex C (normative) Draw gear – Interface dimension		26
Annex D (normative) Screw coupling components – dimensions		27
Annex E (normative) Draw hook and drawbar – Requirements		29
E.1	Physical characteristics	29
E.1.1	Appearance.....	29
E.1.2	Integrity	29

E.1.3	Material examination	29
E.2	Geometrical characteristics	30
E.3	Mechanical characteristics	30
E.3.1	Tensile test on test piece	30
E.3.2	Resilience	30
E.3.3	Hardness	30
E.3.4	Tensile test on draw hook and draw bar	30
E.3.5	Compressive test on draw hook for locomotives	31
E.4	Marking	31
E.5	Manufacture	31
E.5.1	General on draw bars	31
E.5.2	General on draw hooks	31
E.5.3	Machining	31
E.5.4	Heat treatment	31
E.5.5	Rectification of defects	32
E.6	Acceptance	32
E.6.1	General	32
E.6.2	Inspection of the draw hooks	32
E.6.3	Inspection of draw bars	37
E.6.4	Conclusion of the inspections	38
E.7	Delivery	38
E.7.1	Protection against oxidation	38
E.7.2	Packaging	38
Annex F (normative)	Screw coupling and component parts – Requirements	39
F.1	Material	39
F.2	Physical characteristics	39
F.2.1	Appearance	39
F.2.2	Soundness	39
F.2.3	Additional requirements for screw couplings	40
F.3	Geometrical characteristics	40
F.3.1	General	40
F.3.2	Dimensions limited either by two unmachined or rough-machined surfaces or by one unmachined or rough-machined surface	40
F.3.3	Dimensions limited by two machined surfaces	41
F.4	Mechanical characteristics	41
F.4.1	Heat treatment	41
F.4.2	Hardness	41

F.4.3	Values for predetermined breaking loads for the weakest part.....	41
F.4.4	Resilience.....	42
F.4.5	Requirements for screw coupling.....	42
F.4.6	Requirement for handle and trunnion.....	43
F.5	Marking.....	44
F.6	Manufacture.....	44
F.6.1	Preparation of the materials.....	44
F.6.2	Manufacture of the component parts.....	44
F.7	Acceptance.....	46
F.7.1	General.....	46
F.7.2	Inspection of the manufacture.....	46
F.8	Inspection of the materials, component parts and screw couplings.....	46
F.8.1	Materials submission for acceptance.....	46
F.8.2	Grouping into batches.....	47
F.8.3	Nature and proportion of the tests.....	47
F.8.4	Sampling and preparation of the samples and test pieces.....	48
F.8.5	Carrying out of the checks and tests.....	52
F.9	Completion of inspections.....	53
F.10	Delivery.....	54
F.10.1	Protection against oxidation.....	54
F.10.2	Packing.....	54
Annex G (normative)	Elastic device – Requirements.....	55
G.1	Rubber elastomer or other elastomer elastic device.....	55
G.1.1	General.....	55
G.1.2	Metal inserts requirements.....	55
G.1.3	Elastomer requirements.....	55
G.1.4	Static test.....	57
G.1.5	Endurance test.....	58
G.1.6	Bonding.....	59
G.1.7	Inspection and Tests.....	59
G.1.8	Markings.....	60
G.2	Friction spring/Ring spring.....	61
G.2.1	Manufacturer's marks.....	61
G.2.2	Flexibility test.....	61
G.2.3	Endurance test.....	62
Annex H (normative)	Marking.....	63

H.1	General	63
H.2	Marking of the screw coupling.....	63
H.3	Draw gear	64
H.4	Draw bar	64
H.5	Summary of markings	65
Annex ZA (informative) Relationship between this European Standard and the Essential Requirements of EU Directive 2008/57/EC.....		66
Bibliography		68
Figures		
Figure 1	— Force-stroke diagram for stored and absorbed energy	12
Figure 2	— Support plate – Interface dimension for freight wagons.....	15
Figure 3	— Draw gear – Assembly	17
Figure 4	— Standard screw coupling with non-loosening hinged ball handle	19
Figure 5	— Standard screw coupling with hinged handle with non-loosening upper rest.....	20
Figure A.1	— Example of Load cycles Step 1 and Step 2.....	23
Figure B.1	— Draw hook.....	25
Figure C.1	— Drawbar with “fork” and safety device	26
Figure C.2	— Joint pin	26
Figure D.1	— Coupling hook pin	27
Figure D.4	— Shackle.....	28
Figure E.1	— Location of the test samples	34
Figure E.2	— Marking of the draw hook for the tensile test.....	35
Figure E.3	— Location of the test samples	37
Figure F.1	— Location of the measurement of the deformation of the screw coupling.....	42
Figure F.2	— Test facility for the tensile test of the screw coupling.....	43
Figure F.3	— Measurement of the screw coupling.....	43
Figure F.4	— Permitted depth of the fold in thread profile	45
Figure F.5	— Screw - test sample location.....	49
Figure F.6	— Shackle - test sample location	50
Figure F.7	— Coupling link - test sample location	50
Figure F.8	— Trunnion nut (link fitting) - test sample location	51
Figure F.9	— Trunnion nut (shackle fitting) - test sample location.....	51
Figure F.10	— Pin - test sample location.....	52
Figure G.1	— Elastic device - load cycle for endurance test.....	58
Figure G.2	— Elastic device - Set up for endurance test	59
Figure H.1	— Location of mark	64
Figure H.2	— Mark dimension.....	64

Tables

Table 1 — Classification of coupling by designation of the minimum breaking load	13
Table A.1 — Pre-loading values	22
Table A.2 — Condition of dynamic tests for all parts except screw coupling.....	23
Table A.3 — Condition of dynamic tests for screw coupling.....	24
Table E.1 — Requirements.....	30
Table E.2 — Checks and tests	33
Table F.1 — Requirements.....	40
Table F.2 — load of link.....	41
Table F.3 — Breaking load screw	41
Table F.4 — Proportion of the tests - Finished products and component parts	48
Table G.1 — Characteristics of the constituents	55
Table G.2 — Nature of inspections and tests	60
Table G.3 — Number of flexibility tests per batch of springs	62
Table H.1 — Marking.....	65
Table ZA.1 — Correspondence between this European Standard, the Commission Regulation concerning the technical specification for interoperability relating to the subsystem ‘rolling stock - freight wagons’ of the rail system in the European Union and repealing Commission Decision 321/2013/EC, as amended by Commission Regulation (EU) 2015/924 (published in the Official Journal L 150, 17.06.2015, p.10); and Directive 2016/797/EC	66
Table ZA.2 — Correspondence between this European Standard, the Commission regulation (EU) No 1302/2014 of 18 November 2014 concerning the technical specification for interoperability relating to the ‘rolling stock locomotives and passenger rolling stock’ of the rail system in the European Union (published in the Official Journal L 356, 12.12.2014, p.228) and Directive 2008/57/EC	67

European foreword

This document (EN 15566:2016) has been prepared by Technical Committee CEN/TC 256 "Railway applications", the secretariat of which is held by DIN.

This European Standard shall be given the status of a national standard, either by publication of an identical text or by endorsement, at the latest by March 2017, and conflicting national standards shall be withdrawn at the latest by March 2017.

Attention is drawn to the possibility that some of the elements of this document may be the subject of patent rights. CEN shall not be held responsible for identifying any or all such patent rights.

This document supersedes EN 15566:2009+A1:2010.

This document has been prepared under a mandate given to CEN by the European Commission and the European Free Trade Association, and supports essential requirements of EU Directive 2008/57/EC.

For relationship with EU Directive 2008/57/EC, see informative Annex ZA, which is an integral part of this document.

Modifications

Compared with EN 15566:2009+A1:2010 the following main changes have been done:

- a) checking and revision of Clause 2 – Normative references;
- b) modification in Clause 3 – working capacity (3.8) was deleted and intermediate coupling system for permanent coupled wagons now defined as permanent coupling system;
- c) in Clause 4, requirements for compressive loads for draw hook and draw gear rationalised and explained;
- d) in Clause 7, the required value changed into mandatory and given in SI-Unit;
- e) changes in Annex A with respect to the implementation of the dynamic test;
 - new specification of the test load for the residual strength;
 - the macrographic and micrographic tests were added;
 - acceptance criteria were added;
 - modification in Table A.2 and A.3 (rows of survival probability and safety factor were deleted);
- f) revision of Annex E and Annex F to get a similar structure and the requirements of the raw material are defined in the new tables Table E.1 and Table F.1. The marking in Annex E and Annex F were moved into the new Annex H – Marking;
- g) revision of Annex G;
 - specification of the maximum deviation of type test to serial test;
 - revision of Table G.2;

- h) new Annex H – Marking with the marking system for draw hook, draw gear, draw bar and screw coupling as well the new Table H.1 – Marking as summary;
- i) modification of the following figures:
 - Figure 2 – Support plate;
 - Figure 3 – Draw gear;
 - Figure A.1 – Example of load cycles Step 1 and Step 2;
 - Figure E.2 – Marking of the draw hook for the tensile test;
 - Figure E.3 – Location of the test samples (item numbers);
 - Figure F.7 – Coupling link – test samples location (item numbers);
 - Figure F.8 and F.9 – Trunnion nut (item numbers);
 - shifted Figures from Annex E and Annex F to Annex H;
- j) editorial modifications.

According to the CEN-CENELEC Internal Regulations, the national standards organisations of the following countries are bound to implement this European Standard: Austria, Belgium, Bulgaria, Croatia, Cyprus, Czech Republic, Denmark, Estonia, Finland, Former Yugoslav Republic of Macedonia, France, Germany, Greece, Hungary, Iceland, Ireland, Italy, Latvia, Lithuania, Luxembourg, Malta, Netherlands, Norway, Poland, Portugal, Romania, Slovakia, Slovenia, Spain, Sweden, Switzerland, Turkey and the United Kingdom.

Introduction

This European Standard is based on UIC 520, UIC 825, UIC 826, UIC 827-1 and UIC 827-2.

1 Scope

This standard specifies the requirements for the draw gear and screw coupling for the end of rolling stock that has to couple with other rolling stock (freight wagons, locomotives, passenger vehicles ...).

This standard covers the functionality, construction, interfaces and testing including pass/fail criteria for draw gear and screw coupling.

The standard describes three categories of classification of draw gear and screw coupling, (1 MN, 1,2 MN and 1,5 MN).

Coupling systems between permanent coupled vehicle units are not in the scope of this standard.

2 Normative references

The following documents, in whole or in part, are normatively referenced in this document and are indispensable for its application. For dated references, only the edition cited applies. For undated references, the latest edition of the referenced document (including any amendments) applies.

EN 10021, *General technical delivery conditions for steel products*

EN 10025 (all parts), *Hot rolled products of structural steels*

EN 10079, *Definition of steel products*

EN 10083 (all parts), *Steels for quenching and tempering*

EN 10168, *Steel products - Inspection documents - List of information and description*

EN 10204, *Metallic products - Types of inspection documents*

EN 10228-1, *Non-destructive testing of steel forgings - Part 1: Magnetic particle inspection*

EN 10228-2, *Non-destructive testing of steel forgings - Part 2: Penetrant testing*

EN 10243 (all parts), *Steel die forgings — Tolerances on dimensions*

EN 10247, *Micrographic examination of the non-metallic inclusion content of steels using standard pictures*

EN 10308, *Non destructive testing - Ultrasonic testing of steel bars*

EN ISO 148 (all parts), *Metallic materials — Charpy pendulum impact test*

EN ISO 377, *Steel and steel products - Location and preparation of samples and test pieces for mechanical testing (ISO 377)*

EN ISO 643, *Steels - Micrographic determination of the apparent grain size (ISO 643)*

EN ISO 6506-1, *Metallic materials - Brinell hardness test - Part 1: Test method (ISO 6506-1)*

EN ISO 6892-1, *Metallic materials - Tensile testing - Part 1: Method of test at room temperature (ISO 6892-1)*

EN ISO 6892-2, *Metallic materials - Tensile testing - Part 2: Method of test at elevated temperature (ISO 6892-2)*

EN ISO 9606-1, *Qualification testing of welders - Fusion welding - Part 1: Steels (ISO 9606-1 including Cor 1)*

ISO 37, *Rubber, vulcanized or thermoplastic — Determination of tensile stress-strain properties*

ISO 48, *Rubber, vulcanized or thermoplastic — Determination of hardness (hardness between 10 IRHD and 100 IRHD)*

ISO 188, *Rubber, vulcanized or thermoplastic — Accelerated ageing and heat resistance tests*

ISO 813, *Rubber, vulcanized or thermoplastic — Determination of adhesion to a rigid substrate — 90 degree peel method*

ISO 815-1, *Rubber, vulcanized or thermoplastic — Determination of compression set — Part 1: At ambient or elevated temperatures*

ISO 815-2, *Rubber, vulcanized or thermoplastic — Determination of compression set — Part 2: At low temperatures*

ISO 4967, *Steel — Determination of content of non-metallic inclusions — Micrographic method using standard diagrams*

ISO 4968, *Steel — Macrographic examination by sulfur print (Baumann method)*

ISO 7619-1, *Rubber, vulcanized or thermoplastic — Determination of indentation hardness — Part 1: Durometer method (Shore hardness)*

3 Terms and definitions

For the purposes of this document, the following terms and definitions apply.

3.1

screw coupling system

system to connect two railway vehicles consisting of draw gear, draw hook and screw coupling

Note 1 to entry: The screw coupling system defined in this document is also designated UIC coupling.

3.2

draw gear

system consisting of an assembly of mechanical parts and absorber fixed on the railway vehicle which is able to work in traction

Note 1 to entry: A representative drawing is given in Figure 3.

3.3

draw hook

mechanical part to transfer forces between draw gear and screw coupling

Note 1 to entry: Definition in EN 15020 "Rescue coupler": part of a conventional and mechanical manual coupling, also known as UIC draw hook.

3.4

screw coupling

mechanical system to connect to the draw hook of the adjacent railway vehicle including length adjustment

**3.5
Standard screw coupling**

1 MN screw coupling defined on ERRI standard drawings 100M 3220 0001 and 100M 3220 0002 [16].

**3.6
stored energy**

W_e
energy (W_e) stored by the draw gear for a given elasticity stroke

Note 1 to entry: It is represented, on the force-stroke diagram, by the hatched area lying between the compressive curve, the axis of the abscissa and the straight line, perpendicular to the axis, corresponding to the stroke under consideration (see Figure 1 a).

**3.7
absorbed energy**

W_a
energy (W_a) absorbed by the draw gear for a given elasticity stroke

Note 1 to entry: It is represented, on the force-stroke diagram, by the hatched area lying between the compressive curve and the return curve (see Figure 1 b)).

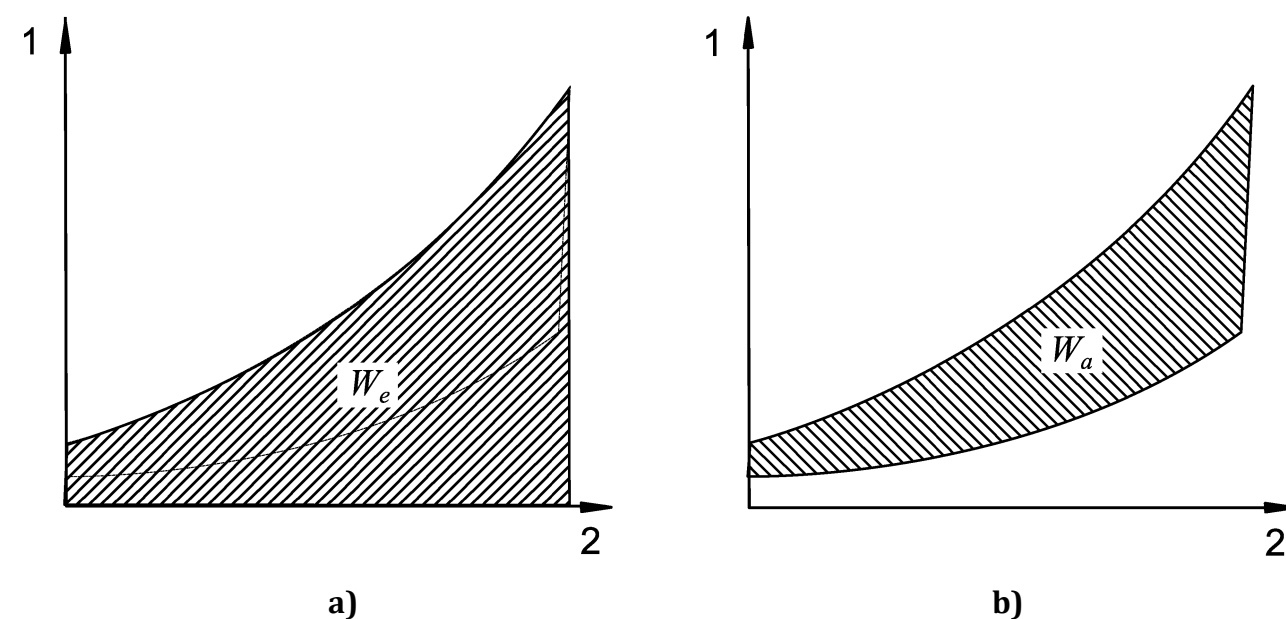

Key



1	force in kN
2	stroke in mm
	stored energy W_e in kJ
	absorbed energy W_a in kJ

Figure 1 — Force-stroke diagram for stored and absorbed energy

**3.8
damping**

d
ratio of absorbed energy divided by stored energy

Note 1 to entry: It is calculated using the following equation:

$$d_{\%} = \frac{W_a}{W_e} \cdot 100 \%$$

where:

$d_{\%}$ is the damping, in %;

W_a is the absorbed energy, in kJ;

W_e is the stored energy, in kJ.

3.9

minimum breaking load

minimum traction force which may lead to mechanical breaking

3.10

technical specification

document describing specific parameters and/or product requirements as an addition to the requirements of this standard

4 Requirements for all types of draw gear and screw coupling

4.1 Classification and designation

Coupling systems are classified according to their minimum breaking load as specified in Table 1.

Table 1 — Classification of coupling by designation of the minimum breaking load

Coupling system designation	Minimum breaking load of the screw coupling MN	Maximum breaking load of the screw coupling MN	Minimum breaking load in traction of the draw gear and draw hook MN
1 MN	0,85	0,98	1,0
1,2 MN	1,02	1,18	1,2
1,5 MN	1,35	1,48	1,5

In case of longitudinal overloading the breaking point of the screw coupling system shall be either the screw or the link of the screw coupling.

NOTE 1 The combination of a screw coupling with draw hooks and/or draw gear with higher breaking loads is possible. The screw coupling system designation is defined by the screw coupling.

Any draw gear and any draw hook shall sustain a 0,05 MN compressive load. Draw gear and draw hook for locomotives shall sustain a 0,3 MN compressive load.

NOTE 2 These compressive loads are needed for shunting operation and rescue operations.

4.2 Interaction coupling/buffer

To ensure that the train is able to negotiate curves at 150 m radius safely, the static characteristics of draw gears and buffers should be coordinated.

In order to meet this requirement for vehicles, a guideline value of 250 kN should not be exceeded for the compression force of a pair of buffers in contact in a curve of 150 m.

To determine the compression force for vehicles, the calculation method shown under section 3 of RP 32 of ORE B 36 [17] may be used (the method described in this report is also applicable for coaches and locomotives). This calculation method may also allow stress levels to be determined on smaller radius curves. If the coupling practice creates pretension forces, these have to be taken into account.

NOTE 1 Using the calculation in curve according RP 32 of ORE B 36 [17] gives also confidence for an S curve of 150 m with an intermediate straight of 6 m.

NOTE 2 When the EN 16839¹ is published, these paragraphs or part of paragraph will not be relevant.

4.3 Interface dimension for freight wagons

Support plate interface dimensions for fixing of draw gear on freight wagons are defined in Figure 2.

Draw gear assemblies shall be interchangeable. The interchangeability only applies to complete draw gear assemblies, not to single draw gear parts.

NOTE For other railway vehicles and for wagons operating on 1 524 mm track gauge, the arrangement could be different and interchangeability is not required.

¹) In preparation.

Dimensions in millimetres

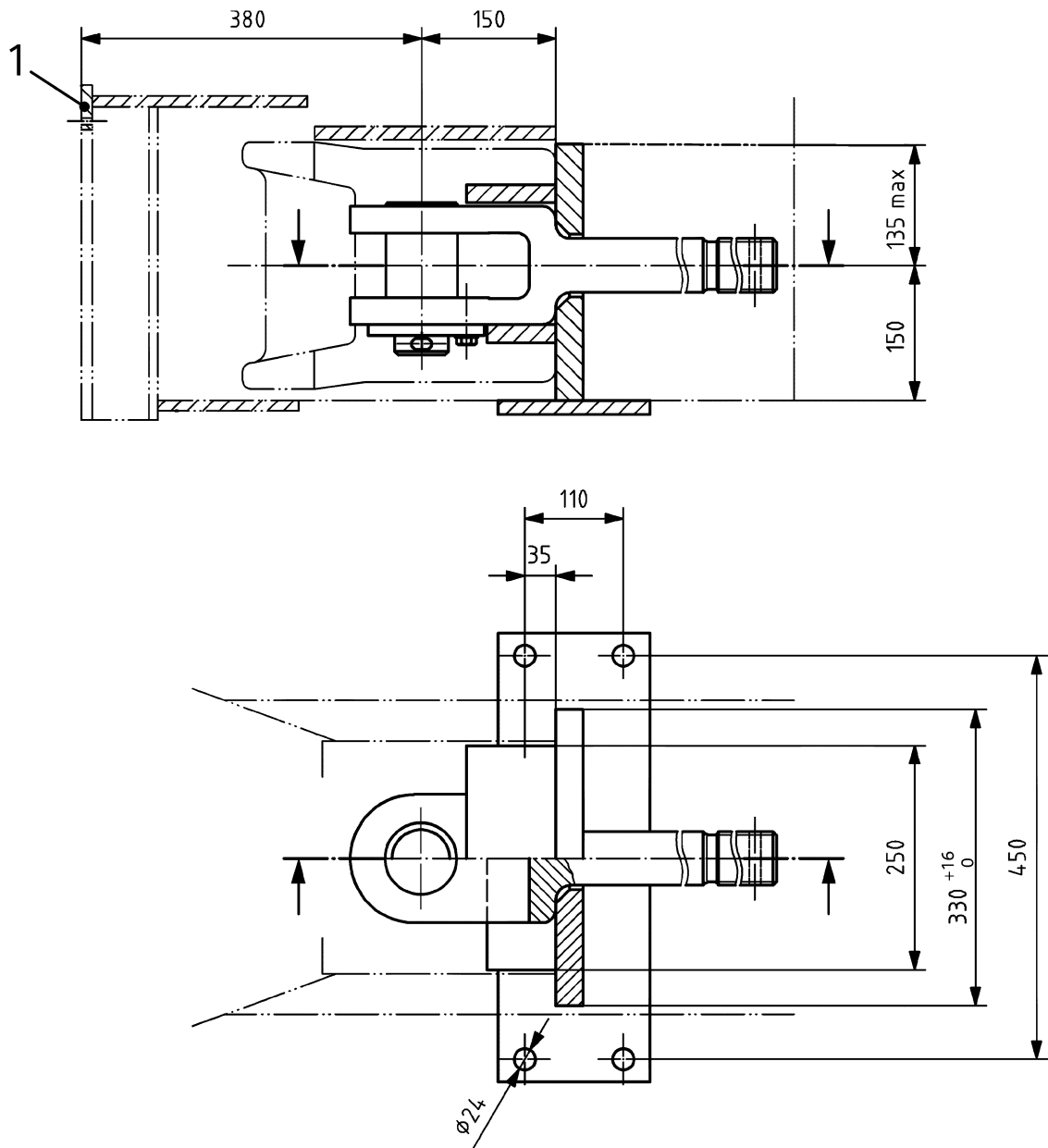

Key

1 buffer fixing plate

NOTE The centreline of the draw gear (screw coupling) is also the centreline of the automatic coupler.

Figure 2 — Support plate – Interface dimension for freight wagons

4.4 Life time

Draw gear (excluding the elastic device), draw hooks, and screw coupling shall be designed commensurate with the service life of a vehicle. Unless otherwise specified, the service life shall be 30 years.

Evidence shall be provided by appropriate means such as service experience, a dynamic test or by Finite Element Analysis (FEA). If a dynamic test is required, it shall be carried out according to the test procedure described in Annex A.

NOTE 1 The FEA and the dynamic test do not give indication of the real life time of a component in operation.

NOTE 2 Life time test qualifies the product and the manufacturer.

5 Draw gear

5.1 Draw gear components

Draw gear assembly see Figure 3 as an example.

The interface dimensions of the draw gear are given in Annex B and Annex C.

Components of a standard draw gear for wagons assembled with draw hook are:

- Draw hook see Figure B.1;
- Drawbar interface dimensions see Figure C.1;
- Joint pin interface dimensions see Figure C.2;
- Elastic device see Clause 7;
- Support plate see 4.3.

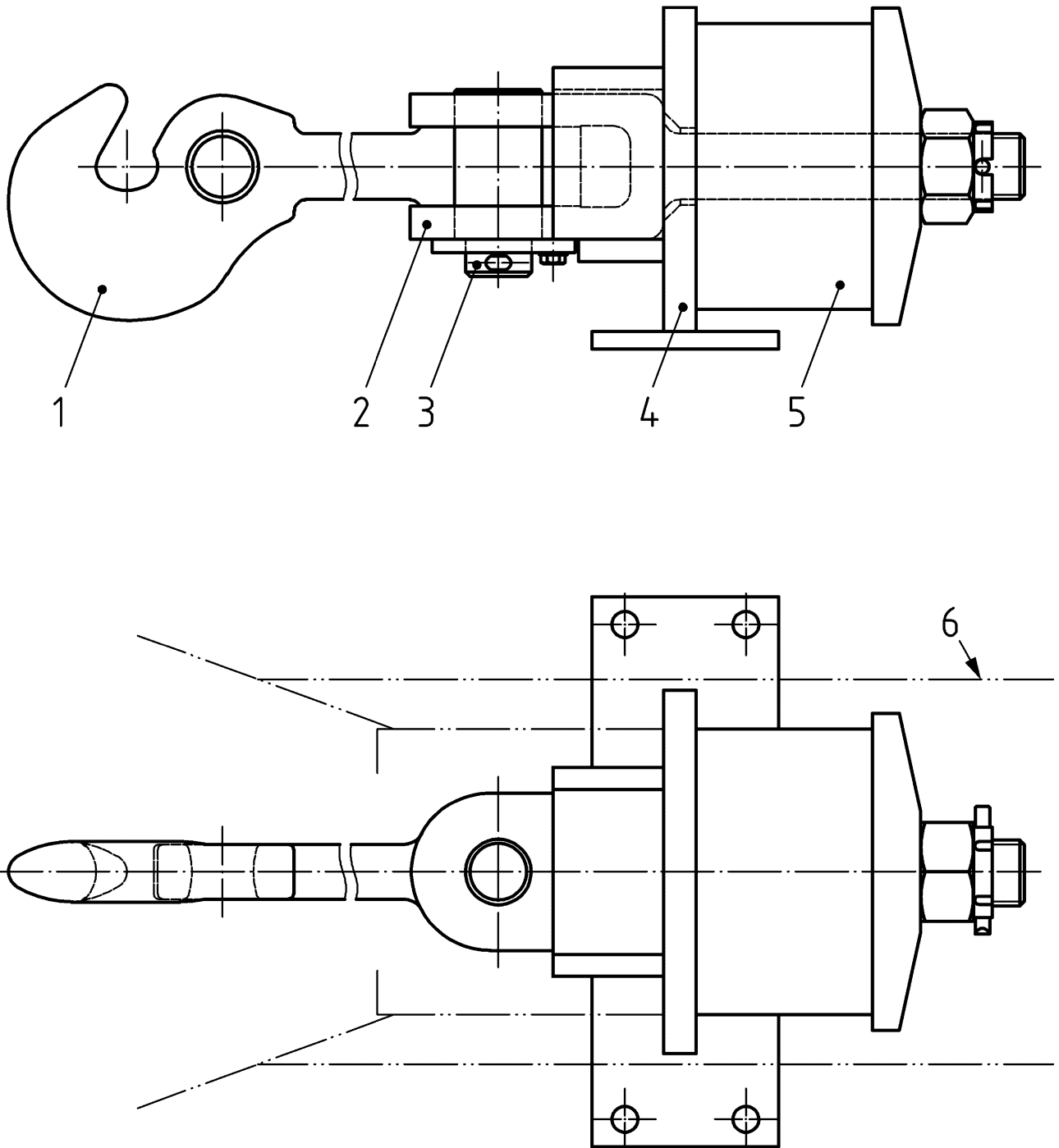

Key

- 1 draw hook (not a part of the draw gear)
- 2 drawbar
- 3 joint pin
- 4 support plate
- 5 elastic device
- 6 underframe

Figure 3 — Draw gear – Assembly

5.2 Draw hook and drawbar – Requirements

Requirements are defined in Annex E.

6 Screw coupling

6.1 General requirements

The mass of the screw coupling shall not exceed 36 kg without coupling hook pin (see item 1 on Figure 4 and Figure 5).

The screw coupler assembly for “standard screw coupling” with non-loosening hinged ball handle shall be as shown in Figure 4.

The screw coupler assembly for “standard screw coupling” with hinged handle with non-loosening upper rest shall be as shown in Figure 5.

NOTE “Standard screw coupling” is the name of the 1 MN screw coupling defined on ERRI standard drawings 100M 3220 0001 and 100M 3220 0002 [16].

The coupling length measured from inside the loop of shackle to the coupling hook pin axis of the coupling screw and draw hook shall comply with the following conditions:

- for the fully loosened coupling: (986^{+10}_{-5}) mm;
- for the fully tightened coupling: (750 ± 10) mm.

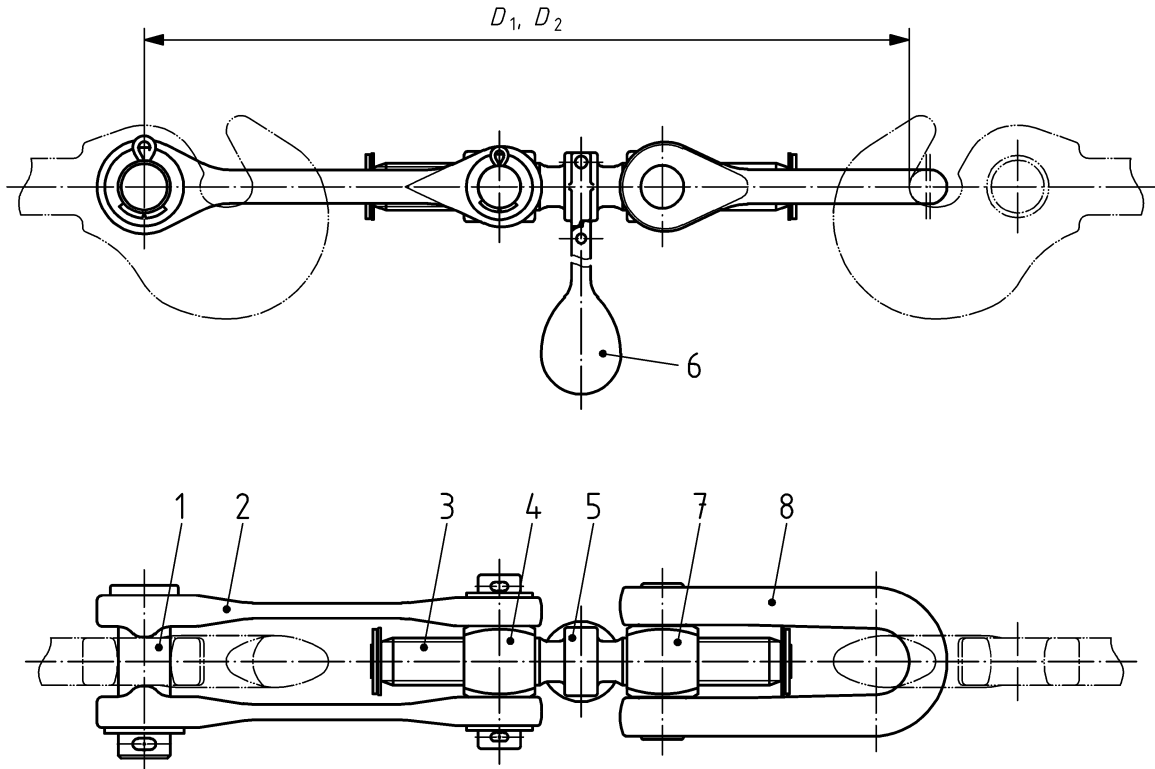

Key

1 coupling hook pin

2 coupling links

3 screw

4 trunnion for ball handle

5 handle housing

6 hinged ball handle

7 trunnion

8 shackle

D_1 greatest length for the fully loosened coupling (986^{+10}_{-5}) mm

D_2 smallest length for the fully tightened coupling (750 ± 10) mm

Figure 4 — Standard screw coupling with non-loosening hinged ball handle

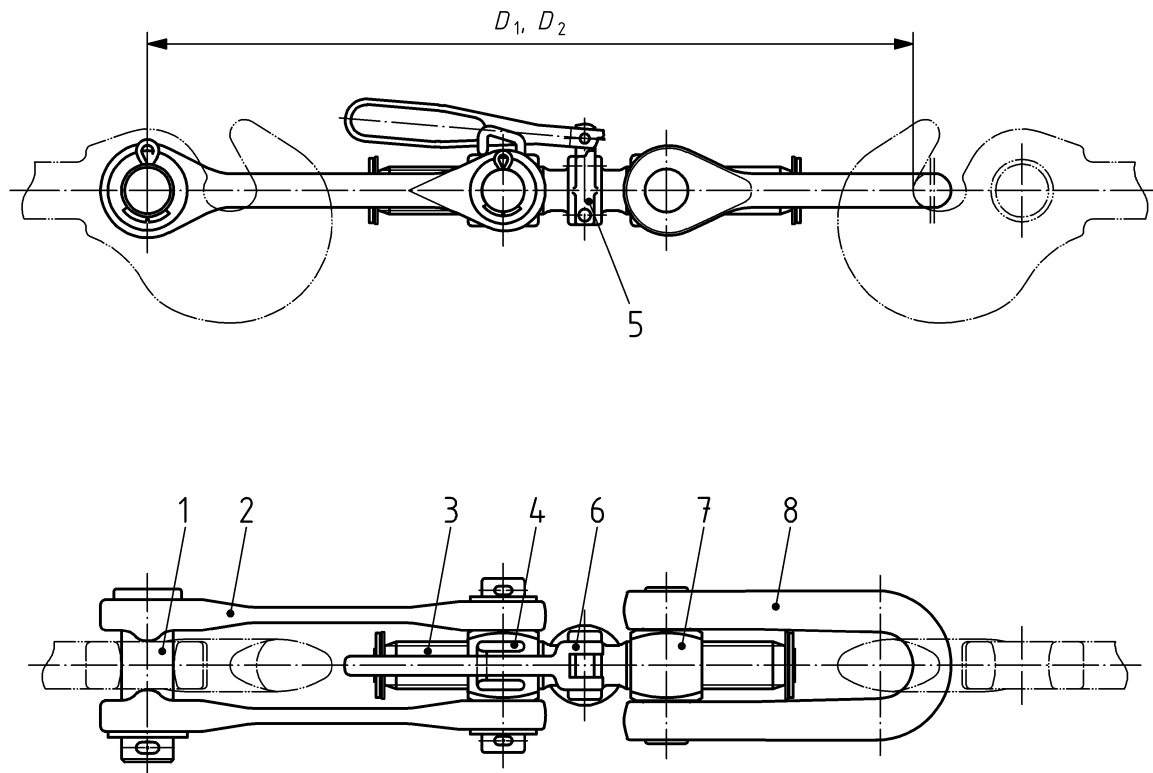

Key

- 1 coupling hook pin
 - 2 coupling links
 - 3 screw
 - 4 trunnion for handle with top-mounted rest
 - 5 handle housing
 - 6 hinged handle
 - 7 trunnion
 - 8 shackle
- D_1 greatest length for the fully loosened coupling (986^{+10}_{-5}) mm
 D_2 smallest length for the fully tightened coupling (750 ± 10) mm

Figure 5 — Standard screw coupling with hinged handle with non-loosening upper rest

Functional dimensions of screw coupling components shall be as given in Annex D.

6.2 Screw coupling – Requirements

Requirements are defined in Annex F.

7 Elastic device

7.1 Characteristics of elastic device

- a) Final force at a stroke of between 50 mm and 60 mm

— mandatory minimum value 400 kN

—	recommended minimum value	550 kN
b)	Pre-compression	
—	mandatory minimum value	10 kN
—	recommended minimum value	20 kN
c)	Static stored energy W_e	
—	mandatory minimum value	10 kJ
—	minimum value in respect of wagons to be equipped with 1,5 MN	20 kJ
d)	Damping d :	
—	mandatory minimum value ($d_0\%$)	30 %

The tests shall be carried out within a temperature range of 10 °C to 25 °C. The decompression period shall immediately follow the compression period, and the maximum speed of movement of the drawbar in either direction shall not exceed 0,05 m/s. After a total release of the elastic device, the conditions shall return to those prevailing initially. The test is described in G.1.4.

7.2 Elastic device – Requirements

Requirements are defined in Annex G.

Annex A (normative)

Dynamic test (fatigue test) procedure

A.1 Background

The test procedure is based on ERRI B 51 / RP 27 [15]. It has been enhanced to provide additional and more detailed instructions and/or recommendations.

This test procedure is also applicable for screw coupling systems for passenger coaches, locomotives and special vehicles other than ERRI B 51/ RP 27

A.2 Performance of the test

A.2.1 Conditioning

- The specimens shall be loaded at least once to the pre-load value given in Table A.1 (corresponding to approximately 75 % of the minimum breaking load, see Table 1)
- Then, the test objects withstanding the longitudinal force shall be checked on the whole surface by MT (Magnetic Particle Testing) or PT (Penetrant Testing) according to relevant EN Standards. Any indications occurring shall be recorded for size and shape.

NOTE Stress measurements can be performed but need not be evaluated in the test report. It is also possible to do several conditioning cycles.

Table A.1 — Pre-loading values

Coupling system designation	Screw coupling kN	Draw gear and draw hook kN
1 MN	640	750
1,2 MN	765	900
1,5 MN	1 010	1 125

A.2.2 Dynamic test (fatigue test)

In the dynamic test, the “Step 1” load cycles shall be interspersed with “Step 2” load cycles at regular intervals. The “Step 2” load cycles can also be combined in blocks (divide their total number into at least 40 blocks). The values of these loads are given in Table A.2 and Table A.3.

- The given load range for Step 1 shall be applied in combination with a lower load which shall not be lower than 10 kN and should not be higher than 50 kN. Hence the upper load limit shall be at least lower load + $\Delta F1$.
- Step 2 is a maximum load. If the test equipment or set-up does not allow load application below a certain minimum load, this value need not be added to the Step 2 maximum load. Holding the maximum force for a period should be avoided.

- Sample of the load-time curve shall be included in the test report.
- The loading frequency should not exceed 4 Hz.

Figure A.1 shows an example for the resulting load course.

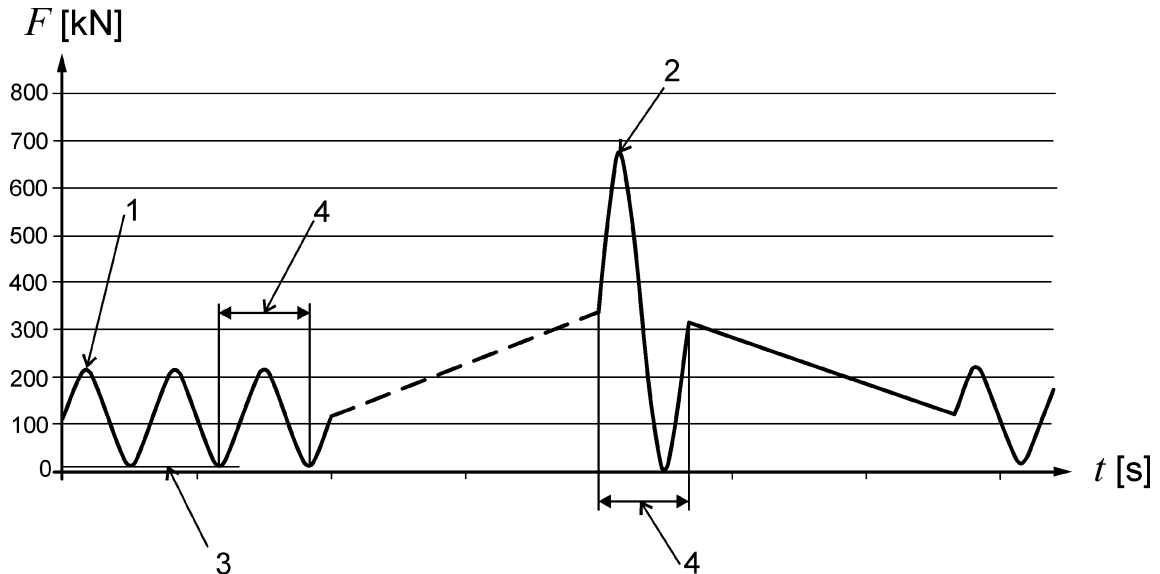

Key

- 1 upper load = lower load + $\Delta F1$
- 2 maximum load $\Delta F2$
- 3 lower load limit for Step 1
- 4 frequency

Figure A.1 — Example of Load cycles Step 1 and Step 2

Table A.2 — Condition of dynamic tests for all parts except screw coupling

Operational requirements	Range of forces to be applied		
	Designation	Step 1	Step 2
Lifecycle in years			
	1 MN	$\Delta F1 = 200 \text{ kN}$	$\Delta F2 = 675 \text{ kN}$
	1,2 MN	$\Delta F1 = 240 \text{ kN}$	$\Delta F2 = 810 \text{ kN}$
	1,5 MN	$\Delta F1 = 300 \text{ kN}$	$\Delta F2 = 1\ 015 \text{ kN}$
		N_1 in cycles	N_2 in cycles
20	all	10^6	$1,45 \times 10^3$
30	all	$1,5 \times 10^6$	$2,15 \times 10^3$

Table A.3 — Condition of dynamic tests for screw coupling

Operational requirements	Range of forces to be applied		
	Designation	Step 1	Step 2
Lifecycle in years			
	1 MN	$\Delta F1 = 170 \text{ kN}$	$\Delta F2 = 575 \text{ kN}$
	1,2 MN	$\Delta F1 = 205 \text{ kN}$	$\Delta F2 = 690 \text{ kN}$
	1,5 MN	$\Delta F1 = 270 \text{ kN}$	$\Delta F2 = 910 \text{ kN}$
		N_1 in cycles	N_2 in cycles
20	all	10^6	$1,45 \times 10^3$
30	all	$1,5 \times 10^6$	$2,15 \times 10^3$

NOTE The range of loading and the number of cycles for a survival probability of 97,5 % are based on a safety factor of 1,7 (See ERRI 51 RP27).

The dynamic tests shall be carried out on three samples of each component:

- draw gear (excluding elastic device);
- draw hook;
- screw coupling.

A.2.3 Non-destructive tests

After the fatigue test, the tested parts shall be checked for cracks by MT (Magnetic Particle Testing) or PT (Penetrant Testing).

A.2.4 Determination of residual strength

After completion of the dynamic test A.2.2 a final static test with a minimum breaking load (see the values given in Table 1) shall be done. 95 % of minimum breaking load shall be sustained over three minutes.

A.2.5 Macrographic and Micrographic tests

Following the residual strength test, macrographic and micrographic tests should be carried out according to the provisions of the Annexes E and F. The macrographic images and polished sections should be preserved because they are used as reference.

A.3 Criteria of acceptance

After the non-destructive tests, the three samples shall not show any cracks exceeding the limits defined by EN 10228-1 Class 1 (MT) and in EN 10228-2, Class 1 (PT).

During the determination of the residual strength, no breaking shall occur.

The results shall be documented in a test report.

Annex B
(normative)

Draw hook – dimensions

For the dimensions of the draw hook see Figure B.1.

Dimensions in millimetres

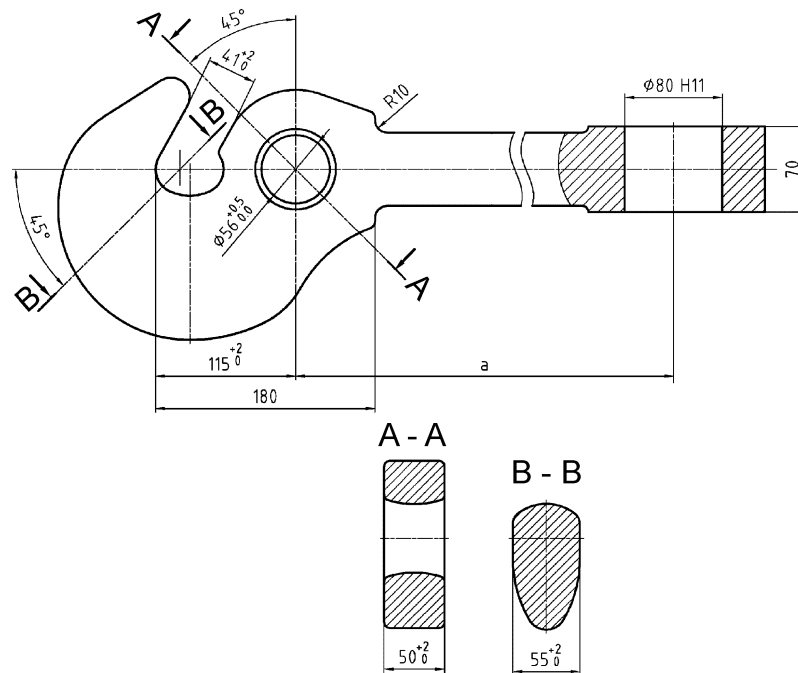

Key

Buffer stroke	<i>a</i>
105	530
150	575

Figure B.1 — Draw hook

The draw hook thickness in Figure B.1 section B - B does not include the marking on the surface. Including the marking, the maximum thickness shall be 61 mm.

NOTE The UIC draw hook is defined on ERRI standard drawings 100M 3211 0001.

Annex C (normative)

Draw gear – Interface dimension

The interface dimensions of the drawbar are given in Figure C.1 and for the joint pin see Figure C.2.

Dimensions in millimetres

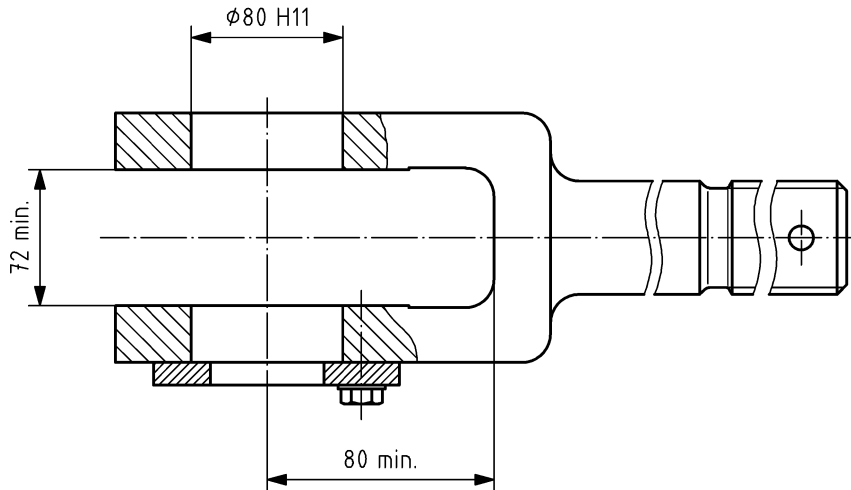

Figure C.1 — Drawbar with “fork” and safety device

Dimensions in millimetres



Figure C.2 — Joint pin

NOTE The UIC drawbar is defined on ERRI standard drawings 100M 3214 0001 [16].

Annex D
(normative)

Screw coupling components – dimensions

The interface dimensions of the coupling hook pin are shown in Figure D.1. The length of handle is shown in Figure D.2 and D.3. See Figure D.4 for the dimensions of the shackle.

Dimensions in millimetres

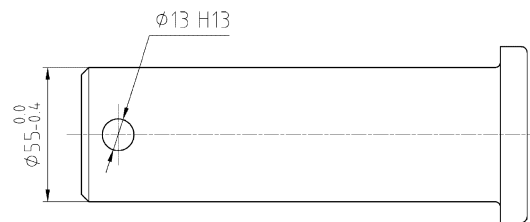

Figure D.1 — Coupling hook pin

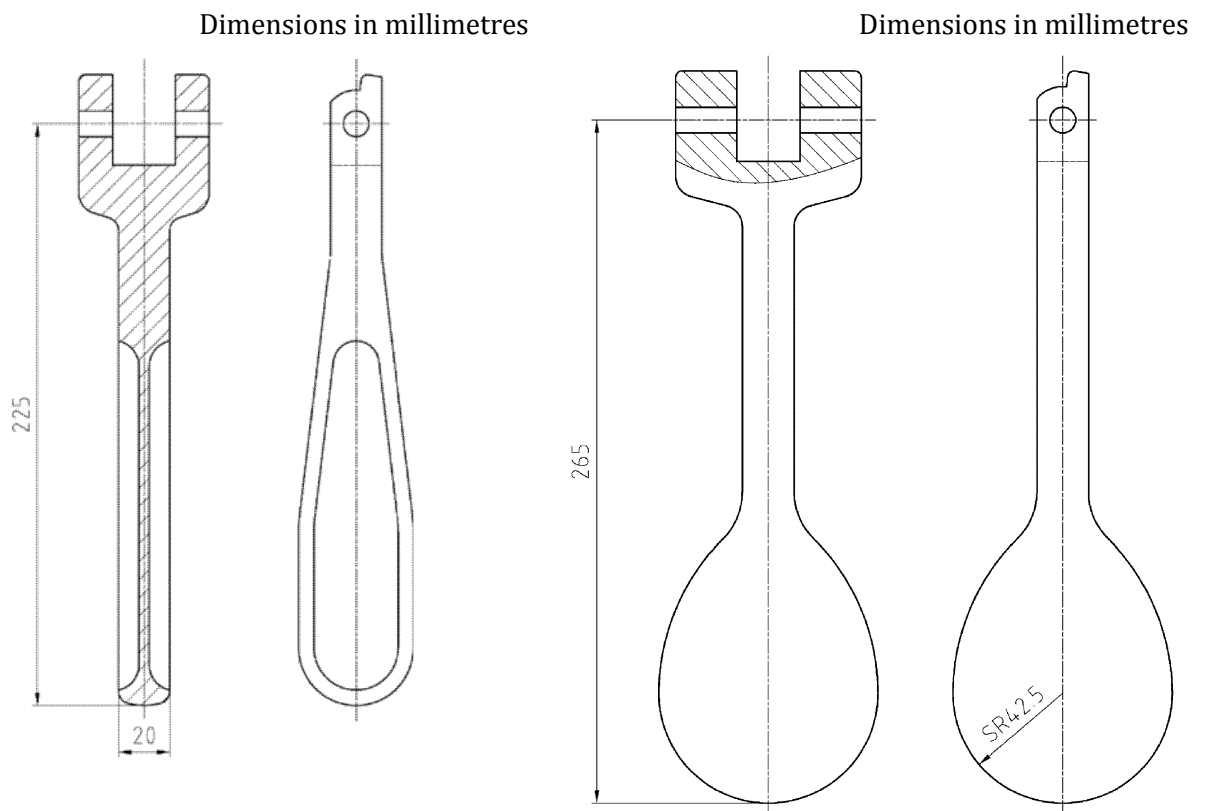

Figure D.2 — Hinged handle

Figure D.3 — Hinged ball handle

Dimensions in millimetres

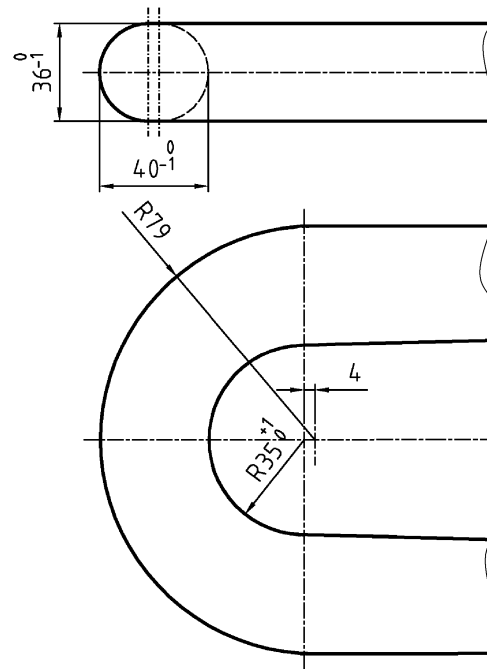

Figure D.4 — Shackle

Annex E (normative)

Draw hook and drawbar – Requirements

E.1 Physical characteristics

E.1.1 Appearance

The parts or sections of parts rough forged or die-forged shall have smooth, carefully trimmed surfaces completely free of oxides.

The surface condition of sections for which machining is prescribed shall comply with the conditions laid down in the technical specification, or demonstrated by the specimens or standards previously acceptance-tested. There shall be no deficiencies, sharp angles or accidental tool marks on the materials used.

Rough or machined connecting radii shall be well formed and free from scoring.

The finish surface of unprocessed sections shall meet the minimum requirements of EN 10243-1. Flash should not fall below the required minimum thickness of the component. Sharp edges and burrs shall be ground.

E.1.2 Integrity

The parts shall be sound throughout and show no defect such as folds, flaws, or cracks (except imperfections of quality class 4 according to EN 10228-1).

E.1.3 Material examination

After a macrographic examination according to ISO 4968 on worked material or in the finished parts on the sections defined in the Figure E.1 and Figure E.3, the sulphurous segregations noted shall fulfil the following conditions:

- the zone where the presence of segregation is noted shall cover less than 10 % of the section and the segregations shall not reach the surface of the part;
- the size of segregation shall be less than 3 mm.

After the micrographic examination according to ISO 4967 on worked material or in the finished parts on the sections defined in the Figure E.1 and Figure E.3, the result shall be compared with those of the accepted reference sample: no air pockets, cavity, discontinuity or non-sulphurous segregation of size or quantity higher than the defects noted on the accepted reference sample shall appear.

NOTE The accepted reference sample is the one tested after the life cycle test or the one designated in the technical specification.

An alternative is to provide a certificate of conformity (EN 10204, 3.1 certificate) for the raw material fulfilling the requirements described in Table E.1.

Table E.1 — Requirements

Characteristic	Requirement
Sulphurous (EN 10083 series)	0,01 % to 0,025 %
Ultrasonic Test (EN 10308)	Quality class 2
Hydrogen content	$H_2 < 2$ ppm
Degree of purity (EN 10247)	$K_4 < 35$
Grain size index G (EN ISO 643)	> 5

E.2 Geometrical characteristics

The shapes, dimensions and their tolerances shall be those stipulated in the technical specification.

Raw parts of the forged drawbars and draw hooks shall fulfil at least the requirements of the EN 10243 series.

E.3 Mechanical characteristics

E.3.1 Tensile test on test piece

The results of the elastic limit, tensile strength and elongation test measured for the draw hook and draw bar in delivery condition shall be in accordance with the material indicated on the drawings.

If stipulated in the technical specification, a second test piece intended to undergo normalization heat treatment may be taken. The values to be obtained shall be specified.

NOTE See Figure E.1, Key 2.

E.3.2 Resilience

The resilience (KU) at 20 °C of the test pieces in the delivery condition:

- in the draw bars shall not be lower than 20 J;
- in the draw hooks shall not be lower than 18 J.

E.3.3 Hardness

The HBW hardness values measured on parts after execution of the heat treatment shall fall within the ranges specified for those parts prescribed in the technical specification or failing any relevant indication, to those specified in the EN 10083 series.

E.3.4 Tensile test on draw hook and draw bar

E.3.4.1 Test under half minimum breaking load

Having being subjected to a tensile load corresponding to half the minimum breaking load, the head of the draw hook shall not show any permanent distortion greater than 0,5 mm (dimension L , see Figure E.2).

Having been subjected to a tensile load of half the minimum breaking load, the draw bar shall not show any permanent distortion greater than 0,2 % of the basic length.

E.3.4.2 Test under minimum breaking load

The draw hook and the drawbar shall be able to withstand a tensile load corresponding to the minimum breaking load for 3 min without cracking or flaw.

E.3.5 Compressive test on draw hook for locomotives

A draw hook alone according to this document that fulfils 300 kN in compression does not need to be tested.

E.4 Marking

Annex H defines the necessary markings.

E.5 Manufacture

E.5.1 General on draw bars

Draw bars shall be manufactured by forging or die-forging without welding. However, the bar head may be welded to the body by flash butt welding by agreement in the technical specification.

The formation of the heads by upsetting may be authorized in the technical specification.

E.5.2 General on draw hooks

The draw hooks shall be manufactured by forging, without welding. In certain special cases, however, flash butt welding may be authorized in the technical specification.

The nuts shall be either forged, or cut from forged, or cut from forged or rolled hexagonal bars.

The forging grade, particularly for products obtained from continuous casting, shall be high enough to ensure that the finished products have the mechanical and soundness characteristics stipulated. The technical specification can specify the forging grade to be observed during manufacture.

Any forging or die-forging operation giving rise to distortion of the metal in the cold state and, in particular, any cold upsetting or straightening operation shall be forbidden.

NOTE The recommended reduction ratio is at least 3. The total elongation ratio is at least 6.

E.5.3 Machining

Machining of the external and internal threads shall be carried out so that the threads are perfectly shaped, with no distortion.

The thread of the screw of the drawbars and drawhooks shall be obtained by rolling process.

The sharp parts formed at the beginning and end of the external and internal threads shall be removed.

E.5.4 Heat treatment

The draw hooks, draw bar and nuts shall undergo the heat treatment for normalization or hardening and tempering, stipulated in the technical specification.

The heat treatment operations shall be conducted to ensure uniformity of the characteristics throughout each part, also on all parts in the same batch.

The heating of the parts shall always be carried out slowly, until the parts have reached a temperature of at least 400 °C.

The temperature of the furnaces shall be checked by means of correctly-calibrated recording pyrometers arranged so that all zones of these furnaces can be checked and regulated accordingly.

The quenching baths shall be equipped with a temperature regulation system.

E.5.5 Rectification of defects

The elimination of surface defects by removal of metal in the cold state (chiselling, filing, grinding or any other approved process) may be authorized subject to observing the dimensional tolerances and providing adequate transition curves with the places where metal has been removed, to avoid any stress concentration and destruction (even partial) of the effects of heat treatment.

NOTE No alterations or repairs may be undertaken without the prior agreement of the customer.

Any weld, resurfacing and any repair intended to hide a defect shall cause the batch to be rejected.

E.6 Acceptance

E.6.1 General

Characteristics shall be checked on the parts. However, the materials intended for the manufacture of draw hooks and draw bars can be inspected and their characteristics checked before use.

E.6.2 Inspection of the draw hooks

E.6.2.1 Submission for acceptance

E.6.2.1.1 Materials

Should a special agreement exist to this effect, the rolled products shall be submitted as forged in the delivery condition stipulated in the technical specification for the draw hooks.

E.6.2.1.2 Parts

If required, the parts shall be submitted for acceptance after machining and heat treatment and before any application of a protective product against oxidation.

E.6.2.2 Grouping into batches

Each batch shall comprise a maximum of 200 draw hooks produced during the same operation and from the same manufacture. Draw hooks shall have respectively undergone the same heat treatment.

E.6.2.3 Advice of inspection

If the technical specification states that the customer requires to be present at inspection then the date shall be advised. This advice shall indicate the number of parts presented, the composition of the batches and their identification marks, and the references of the technical specification involved.

E.6.2.4 Nature and extent of checks and tests

E.6.2.4.1 Materials

Each batch of steel produced under the conditions prescribed in E.6.2.2 shall, on submission for acceptance, be subjected to the checks and tests the nature and extent of which are stipulated in Table E.2 hereinafter.

E.6.2.4.2 Parts

Each batch of draw hooks or draw bars shall, on submission for acceptance, be subjected to the checks and tests the nature and extent of which are stipulated in Table E.2 hereinafter.

Table E.2 — Checks and tests

Nature of the checks and tests	Extent of the checks and tests	
Materials checks on the characteristics stipulated in E.6.2.1.1 ^a	1 series of tests per batch	
Parts	1 to 200	for each additional batch
Chemical composition	1 per casting	
Appearance, dimensions, marking	as stated in the technical specification	
Micrographic and macrographic test ^a	1 per casting	
Tensile test on a test piece in delivery condition — in delivery condition — having undergone heat treatment for normalization ^a	1	1
Resilience on a series of 2 U-notched test pieces	1	1
Hardness	100 %	100 %
Tensile test on parts	1	1
^a If stipulated in the technical specification.		

E.6.2.5 Sampling and preparation of the samples and test pieces

E.6.2.5.1 Sampling

The macrographic examinations, the chemical analyses as well as the resilience and tensile tests may be carried out on parts which have undergone the tensile test.

E.6.2.5.2 Preparation of the samples and test pieces

E.6.2.5.2.1 General

The preparation of the samples and test pieces shall be carried out in accordance with the provisions of EN ISO 377.

E.6.2.5.2.2 Materials

The tensile strength and resilience shall be checked on test pieces taken parallel to the rolling direction, cut up and treated as follows:

- the sample shall consist of a section of the original semi-manufactured product elongated by forging along its longitudinal centre-line. The forging grade between the sample and the semi-manufactured product shall be equal to 3;
- the sample shall undergo either normalization treatment in the case of normalized parts, or hardening and tempering in the case of hardened and tempered parts;
- the test pieces shall be extracted by machining from the sample treated. Irrespective of the section of the product, the longitudinal centre-line of the test pieces shall be situated 12,5 mm from the surface of the sample in rough-finished condition.

E.6.2.5.2.3 Component parts

— Chemical composition

The sample for checking the chemical composition shall consist of a full section plate, cut parallel to the section intended for the macrographic examination (see Figure E.1) or of shavings representing the full section and weighing at least 50 g.

— Macrographic and micrographic examinations

The position of the section to be examined shall be as indicated in Figure E.1. The surface of this section shall be carefully machined, polished and degreased.

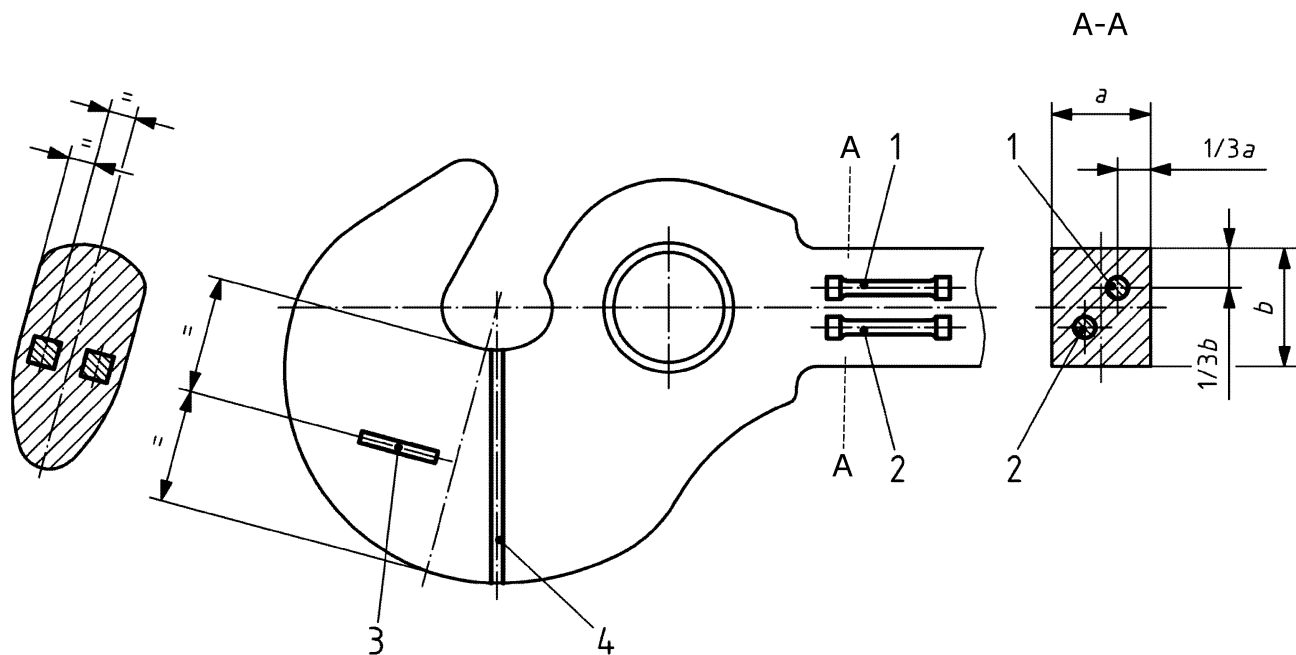

Key

- 1 tensile test sample delivery condition
- 2 tensile test sample normalized
- 3 impact test sample
- 4 macrographic and micrographic examination sample

Figure E.1 — Location of the test samples

— Tensile test on test pieces

The tensile test sample(s) shall be cut from the locations defined in Figure E.1.

Machine the test pieces in accordance with EN ISO 6892-1.

— Impact test

Two impact test pieces with U-shaped notches shall be cut from the positions defined in Figure E.1. The direction of the notch of each of the test pieces shall be that shown in the same figure.

The test pieces shall be machined in accordance with EN ISO 148-1 to 3.

— **Hardness**

The test pieces shall consist of the parts themselves, which shall have the oxide removed by milling or grinding to a depth of about 2 mm in the position indicated in Figure E.2, unless the technical specification defines an alternative location.

— **Tensile test on draw hook**

The draw hooks shall be marked as is shown in Figure E.2. One mark shall be placed in a diametral plane of the hook-eye bore, and the other in a plane passing through the centre-line of the coupling-screw housing (L).

The draw hooks shall be tested with their joint pin.

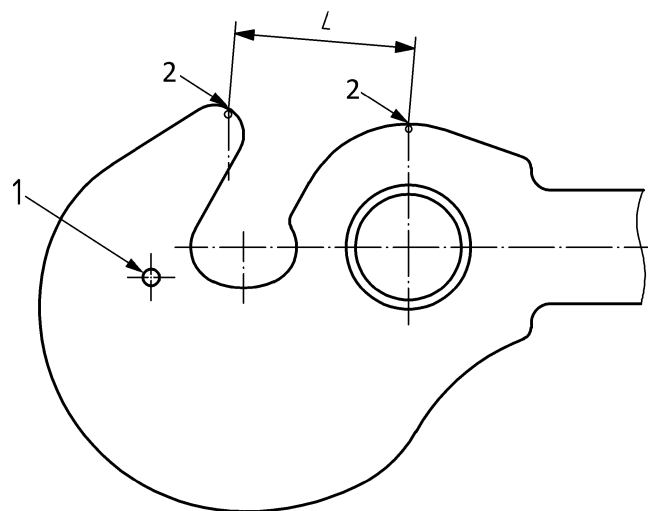

Key

- 1 location of hardness test
- 2 location of marks for tensile test
- L distance between the two marks

Figure E.2 — Marking of the draw hook for the tensile test

E.6.2.6 Organization of checks and tests

E.6.2.6.1 Materials

The tests shall be carried out in accordance with the provisions of the following standards:

Steel-Tensile test	EN ISO 6892-1 and -2;
Steel-Charpy resilience test (U-shape notch)	EN ISO 148-1 to -3;

The provisions of E.6.2.1.1 shall be observed.

E.6.2.6.2 Component parts

E.6.2.6.2.1 Chemical composition

The methods for determining the amounts of the various components shall be those defined for each of them in the ISO standards. In cases of disagreement, spectrographic analysis can be used.

The instructions of E.6.2.1.1 shall be observed.

E.6.2.6.2.2 Appearance and soundness of the parts

The surface conditions, in particular those of the transition curves between rough-finished and machined parts, shall be examined.

If there is any doubt, additional methods of investigation: dye penetrant, magnetic particle examination, etc. shall be applied.

The provisions of E.1.1 and E.1.2 shall be observed.

E.6.2.6.2.3 Checking the geometrical characteristics

Checks to verify the dimension of parts shall be carried out by any suitable means, in particular using manufacturer's calibrated gauges.

The external and internal threads shall be checked by means of limit-gauges approved in the technical specification.

The provisions of E.2 shall be observed.

E.6.2.6.2.4 Tensile test

The tensile test shall be carried out in accordance with the provisions of EN ISO 6892-1.

The provisions of E.3.1 shall be observed.

E.6.2.6.2.5 Resilience

The resilience test on U-notched test pieces shall be carried out in accordance with the instructions in EN ISO 148-1. The test shall be carried out at a temperature of 20 °C.

The provisions of E.3.2 shall be observed.

E.6.2.6.2.6 Hardness test

The HBW 10/3 000 hardness test shall be conducted in accordance with the provisions of EN ISO 6506-1.

The provisions of E.3.3 shall be observed.

E.6.2.6.3 Tensile test on draw hook or component parts

E.6.2.6.3.1 Preparation of draw hook

The draw hook or the component parts, prepared as indicated in E.6.2.5.2.3, shall be placed on a tractive unit or in a test rig by means of a securing device so that the force is applied to the parts under conditions identical to those of use.

The draw hook shall be subjected to an initial tensile force of 50 kN. The distance between marks, determined under the effect of these forces shall be taken as the initial length.

E.6.2.6.3.2 Test under half load

The tensile load shall be gradually further increased up to a load equal to or as little as possible above half the minimum breaking load, maintained for at least 1 min before the force is reduced to its initial value 50 kN.

The distance between marks shall then be recorded, and any permanent distortion shall not be greater than that indicated in E.3.4.1.

E.6.2.6.3.3 Test under minimum breaking load

The tensile load shall again be gradually increased up to a load equal to or as little as possible above the minimum breaking load, maintained for 3 min and then released. The parts shall then be examined.

The provisions of E.3.4.2 shall be observed.

E.6.3 Inspection of draw bars

E.6.3.1 Nature and extent of checks and tests

E.6.3.1.1 Materials

Unless defined in the technical specification, the steel used for the manufacture of draw bars shall be selected from the EN 10083 series, including its metallurgical condition.

The steel characteristics as defined shall be checked and the range of checks and tests shall be that specified in Table E.2.

E.6.3.1.2 Draw bars

Each batch shall comprise a maximum of 200 draw bars. Each batch of draw bars shall, on submission for acceptance, be subjected to the checks and tests as stipulated in Table E.2.

E.6.3.2 Sampling and preparation of samples and test pieces

The provisions of E.6.2.5 shall apply to draw bars. The test pieces shall be taken from the external $1/3$ of the radius or half-diagonal of the bar.

Test pieces shall be cut at the positions defined in Figure E.3 below. The draw bars intended for the tensile test shall be marked in accordance with the provisions of Figure E.3.

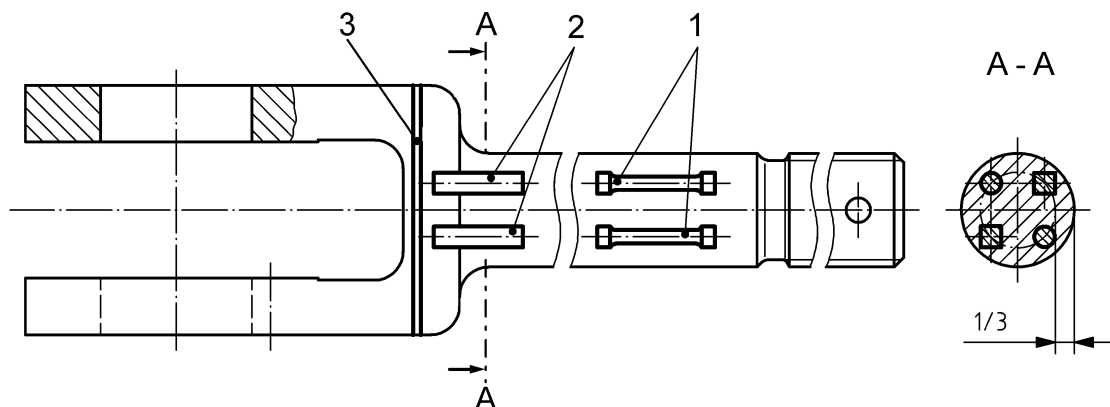

Key

- 1 tensile test sample
- 2 impact test sample
- 3 macrographic and micrographic examination sample

Figure E.3 — Location of the test samples

Plan of symmetry for impact test samples according to Figure E.3 shall be located closest to the face of section A-A.

E.6.3.3 Organization of checks and tests

The provisions of E.6.2.6.1 and E.6.2.6.2 shall apply to the draw bars. The values to be observed shall be in accordance with the material indicated on the drawings or failing that any relevant indication to those specified in the relevant part of the EN 10083 series.

E.6.3.4 Tensile test on draw bars

E.6.3.4.1 Preparation of draw bars

The draw bar shall be placed on a tractive unit using a securing device so that the load is applied under conditions identical to those of use.

The draw bar shall be subjected to an initial tensile load of 45 kN. The distance between marks, determined under the effect of this load, shall be taken as the initial length.

E.6.3.4.2 Test under half minimum breaking load

The tensile load shall be gradually further increased up to a load equal to or as little as possible above the half minimum breaking load, maintained for at least 1 min before it is reduced to its initial value of 45 kN. The distance between marks shall then be recorded and any permanent distortion shall not be greater than 0,2 % of the initial length.

E.6.4 Conclusion of the inspections

Any characteristic not conforming to the provisions of this European standard shall lead to rejection of the corresponding batch.

If rejection has been decided because of unsatisfactory test results, further tests, with or without any heat treatment for improvement, may only be carried out by an amendment to the technical specification.

E.7 Delivery

E.7.1 Protection against oxidation

All uncovered metallic parts shall be protected against corrosion before delivery except if otherwise agreed in the technical specification.

E.7.2 Packaging

The parts shall be effectively protected by suitable packaging according to the technical specification to avoid any deterioration, particularly of the machined parts, or deformation during handling or transit.

Annex F (normative)

Screw coupling and component parts – Requirements

F.1 Material

The impact strength KV at 20 °C of the material shall be greater than 25 J.

Unless defined in the technical specification, materials, including their metallurgical condition, shall be selected from the EN 10083 series.

NOTE For an air temperature range external from the vehicle from –40 °C to +35 °C, the impact test KV at lower temperature is not a criterion for determining the low temperature capability of a screw coupling.

F.2 Physical characteristics

F.2.1 Appearance

Parts or components in the as-forged, as-stamped or as-cast condition shall have smooth surfaces, carefully trimmed and be completely free of oxides and any foundry sand. In particular, the handle and ball shall be free from burring, unevenness or other defects likely to make it dangerous to operate.

The surface condition of parts for which machining is laid down shall conform to that prescribed in the technical specification. No lack of material, sharp angles or accidental tool marks shall be accepted, particularly on parts or components subject to tensile or bending stresses.

Connecting radii, whether machined or not, shall be correctly formed and free from scoring.

The surface finish of unprocessed sections shall meet the minimum requirements of EN 10243-1 and the surface oxide should not compromise the minimum thickness of the components. Sharp edges and burrs shall be removed.

F.2.2 Soundness

F.2.2.1 General

For machined surfaces, the component parts of the screw couplings shall be sound throughout and show no defect such as laps, seams or cracks, irrespective of their size.

For unmachined surfaces, the component parts of the screw couplings shall be sound throughout and show no defect such as laps or cracks except cracks quality class 4 in accordance with EN 10228-1.

F.2.2.2 Material examination

After a macrographic examination according to ISO 4968 on worked material or in the finished parts on the sections defined in the Figure F.5 to Figure F.10 the sulphurous segregations noted shall fulfil the following conditions:

- the zone where the presence of segregation is noted shall cover less than 10 % of the section and the segregations shall not reach the surface of the part;
- the size of segregation shall be less than 3 mm.

After the micrographic examination according to ISO 4967 on worked material or in the finished parts on the sections defined in the Figure F.5 to Figure F.10 the result shall be compared with those of the

accepted reference sample: no air pocket, cavity, discontinuity or non-sulphurous segregation of size or quantity higher than the defects noted on the accepted reference sample shall appear.

NOTE The accepted reference sample is the one tested after the life cycle test or the one designated in the technical specification.

An alternative is to provide a certificate of conformity (EN 10204, 3.1 certificate) for the raw material fulfilling the requirements described in Table F.1.

Table F.1 — Requirements

Characteristic	Requirement
Sulphurous (EN 10083 series)	0,01 % to 0,025 %
Ultrasonic Test (EN 10308)	Quality class 2
Hydrogen content	$H_2 < 2$ ppm (ppm = parts per million)
Degree of purity (EN 10247)	$K_4 < 35$
Grain size index G (EN ISO 643)	> 5

F.2.3 Additional requirements for screw couplings

The screw/trunnion nut assembly shall move freely without the need to apply excessive force on the end of the handle.

All pin joints shall move freely.

The handle shall fit firmly onto the screw to avoid any subsequent play.

F.3 Geometrical characteristics

F.3.1 General

The shapes, dimensions and their tolerances shall be those fixed, for each category of component parts, in the technical specification. Failing any indication to this effect, the following tolerances shall be complied with F.3.2 or F.3.3 (depending on what is appropriate).

NOTE The tolerances js15, js16, Js16, h13, h15, H13, k15, are those specified in EN ISO 286-1.

F.3.2 Dimensions limited either by two unmachined or rough-machined surfaces or by one unmachined or rough-machined surface

a) transverse dimensions:

Dimensions determining the section of the parts subject to tensile stress:

- shackles:(burned portion between the 2 parallel arms): h15
- (other parts): js15
- links: k15
- other dimensions: Js16 or js16
- other parts: Js16 or js16

b) longitudinal dimensions (all parts): Js16 or js16

F.3.3 Dimensions limited by two machined surfaces

a) linear dimensions:

- bores (internal diameters): H13
- shafts (external diameters): h13

b) angular dimensions: $\pm 2^\circ$

F.4 Mechanical characteristics

F.4.1 Heat treatment

At the time of delivery, the screws, shackles, links, trunnion nuts and pins shall be in the metallurgical condition, either normalized or hardened or tempered, required by the technical specification which, for hardened parts, shall also specify the area of hardening.

No heat treatment of the handles, washers and rivets is required.

F.4.2 Hardness

The HBS or HBW hardness values measured on parts after execution of the heat treatment shall fall within the ranges specified to those prescribed in the technical specification or failing any relevant indication to those specified in the EN 10083 series.

F.4.3 Values for predetermined breaking loads for the weakest part

The weakest part shall be either the link or the thread.

If the predetermined weakest point is the link, the links, in the delivery condition, shall fracture under a tensile load as defined in Table F.2.

Table F.2 — load of link

Coupling system designation	Minimum breaking load of the link MN	Maximum breaking load of the link MN
1 MN	0,425	0,49
1,2 MN	0,51	0,59
1,5 MN	0,675	0,74

If the predetermined weakest point is the screw, the screw, in the delivery condition, shall fracture under a tensile load as defined in Table F.3.

Table F.3 — Breaking load screw

Coupling system designation	Minimum breaking load of the screw MN	Maximum breaking load of the screw MN
1 MN	0,85	0,98
1,2 MN	1,02	1,18
1,5 MN	1,35	1,48

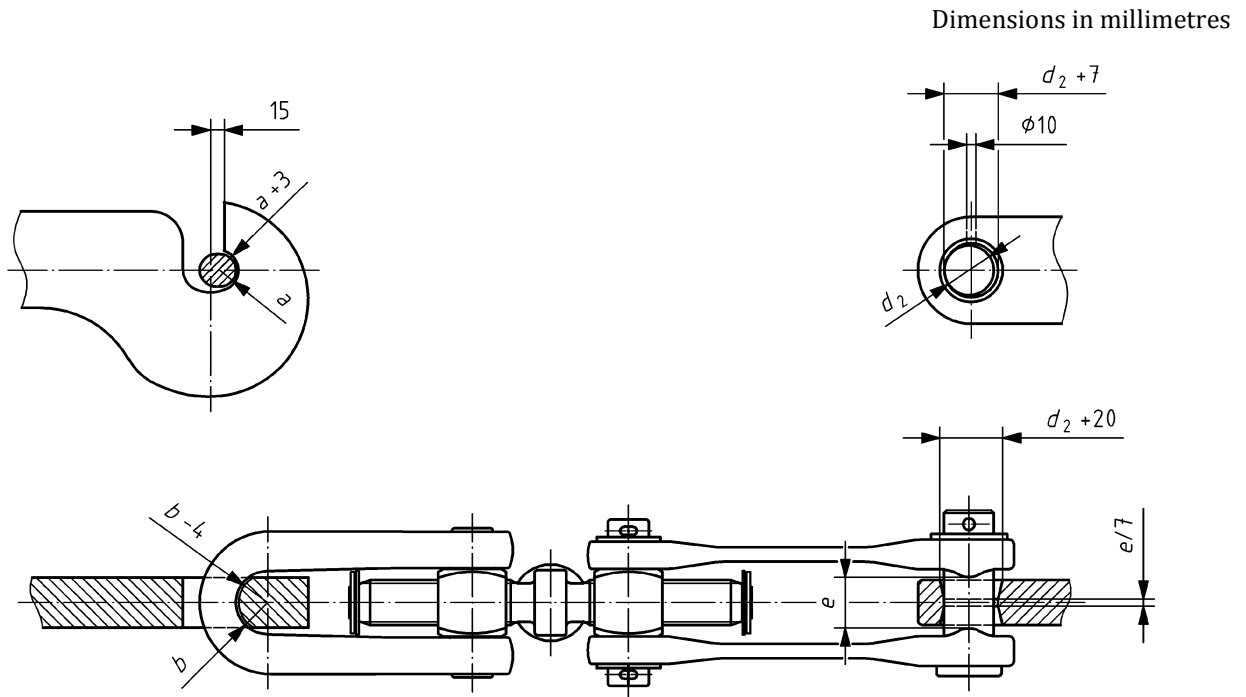
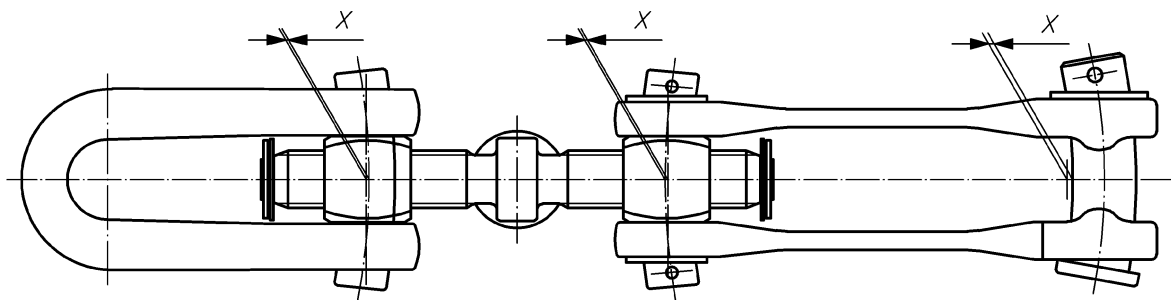

Figure F.2 — Test facility for the tensile test of the screw coupling



Key

X sag

Figure F.3 — Measurement of the screw coupling

F.4.5.2 Test under minimum breaking load

The assembled screw couplings shall be able to withstand, without fracture and without cracking, 95 % of minimum breaking load given in Table 1 maintained for 3 min.

F.4.5.3 Test under maximum breaking load

The assembled screw couplings shall break lower or equal to the maximum value given in Table 1 and greater or equal to the minimum value given in Table 1.

F.4.6 Requirement for handle and trunnion

The hinged handle (or hinged ball handle), including its link with the screw, shall withstand at least the same operational forces as the hinged handle (or hinged ball handle) defined by the standard screw coupling.

The weight of the hinged ball handle shall be at least 3,5 kg.

F.5 Marking

Annex H defines the necessary markings.

F.6 Manufacture

F.6.1 Preparation of the materials

For any orders, the Certificate 3.1 or 3.2 according to EN 10204 and EN 10168 and the European standards corresponding to the materials used for the manufacture of the screw coupling (the actual chemical composition as well as the test results of tensile, resilience and hardness shall be indicated therein) shall be available.

F.6.2 Manufacture of the component parts

F.6.2.1 Forging and stamping

Any forging operation involving deformation of the metal when cold and, in particular, any cold upsetting operation is forbidden. All parts shall be free from laps or folds.

The shackles and links shall be obtained by partial or complete drop stamping.

The shackles shall be hot formed.

The forging of the trunnions shall be carried out so that the axis of the pin ends coincides with the axis of the bar used.

The holes in the various forgings may be formed by hot punching to a diameter permitting finishing by machining or by a process previously approved in the technical specification.

Trunnions, shackle and coupling links shall be manufactured by forging.

The recommended reduction ratio is at least 3. The total elongation ratio is at least 6.

F.6.2.2 Machining

The manufacture of trunnions entirely by machining from solid bars may be allowed only after prior agreement in the technical specification and in accordance with the process laid down by it.

All machining burrs shall be carefully removed.

The thread of the screw of the screw coupling shall be produced by rolling.

Central bore-holes at the ends of the coupling screw are acceptable provided this does not prevent marking of the screws.

The maximum permitted deepness of the fold in thread profile at the major diameter is 0,8 mm, see Figure F.6.

Dimensions in millimetres

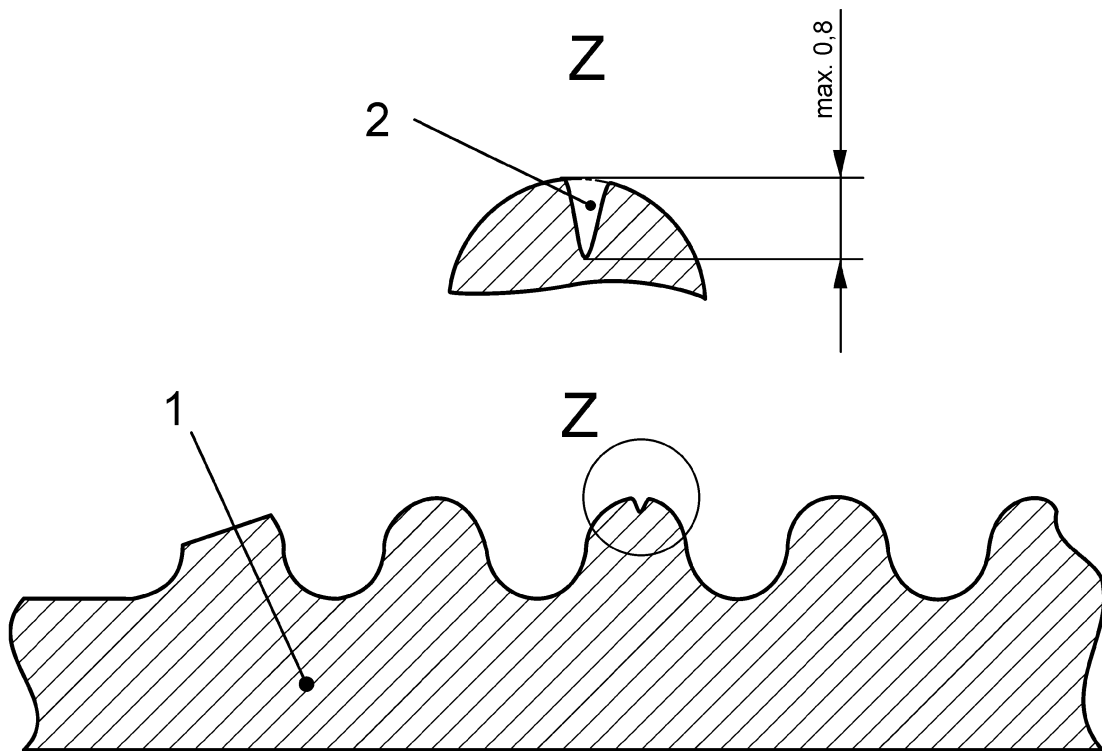

Key

- 1 screw
- 2 fold

Figure F.4 — Permitted depth of the fold in thread profile

To facilitate the rolling process, a lead in taper is permitted on the first and last three threads.

F.6.2.3 Heat treatment

To avoid decarburization, heat treated parts shall be heated in a non-oxidising atmosphere, except if the choice of steel allows an oxidising atmosphere.

F.6.2.4 Assembly of the component parts

Failing any indication to the contrary in the technical specification, the assembly of the shackles and their trunnions shall be carried out before heat treatment. This operation may be carried out when cold.

If, by special agreement, it is permitted that the trunnion be assembled in the shackle after the heat treatment, this operation may only be effected after re-heating of the shackle and under conditions defined in the technical specification.

F.6.2.5 Retouching

No retouching or repair may be carried out without the prior agreement in the technical specification.

The elimination of superficial defects by removal of metal when cold (chiselling, filing, grinding or other approved process) may be authorized subject, however, to compliance with the dimensional tolerances and provided the effects of the heat treatment are not destroyed.

Any weld, resurfacing and any repair intended to hide a defect shall cause the batch to be rejected.

F.6.2.6 Welding

The welders shall be qualified in accordance with EN ISO 9606-1.

The choice of welding procedures shall be defined unless specified in the technical specification. It is recommended that welding procedures should meet the requirements of the EN 15085 series of standards and its referenced normative standards.

NOTE For information, the following procedures have previously been accepted:

- arc welding with stainless steel electrode;
- MAG arc welding with active gas shield and a consumable stainless steel electrode.

F.7 Acceptance

F.7.1 General

Failing any indication to the contrary in the technical specification, the materials intended for the manufacture of the component parts of the screw coupling shall be subjected, before use, to inspection of their manufacture and their characteristics. However, by special agreement, these characteristics may be checked on the components.

The chemical and mechanical characteristics of the materials shall be checked on the component parts of standard screw couplings.

F.7.2 Inspection of the manufacture

It shall be possible to ascertain, by any checks considered necessary, that the manufacturing conditions prescribed in the technical specification are fully complied with in respect of the materials, component parts and screw couplings themselves.

F.8 Inspection of the materials, component parts and screw couplings

F.8.1 Materials submission for acceptance

The delivery of rolled products shall be accompanied by a certificate of conformity (3.1 certificate) or an acceptance report (3.2 certificate) given in EN 10204 containing the following information:

- address of the factory that made them;
- manufacturing process;
- method of casting (ingot or continuous);
- delivery condition;
- for certain rolled or forged semi-finished products (as specified in EN 10079), the rate of rolling.

When a metallurgical product or semi-finished product is supplied by a manufacturer (rolling mills, finishers, etc.) or an intermediary (stockist) as specified in EN 10021, the manufacturer's document specified above shall be provided, together with some appropriate means of identifying the product in order to ensure traceability between the product and the document.

If the manufacturer or the intermediary modifies the state or the dimensions of the metallurgical product or semi-finished product in any way an additional certificate of conformity shall be supplied (EN 10204, 1.3) covering these new special conditions.

Cast steel parts shall be presented in the rough foundry condition and after normalization.

F.8.2 Grouping into batches

F.8.2.1 General

A batch is a group of component parts of the same type, originating from the same melt of raw material and having undergone the same process of manufacturing.

The batch size refers to the entire production charge of the manufacturer, not to the order size of the customer.

F.8.2.2 Materials

F.8.2.2.1 Rolled products

The conditions for grouping into batches shall be those prescribed in the technical specification, particularly those defined in the specifications (see ISO Standards, European standards EN) to which reference is made.

F.8.2.2.2 Component parts

The component parts shall be grouped into uniform batches consisting of parts from the same manufacture and having undergone the same heat treatment.

F.8.2.2.3 Screw couplings

Each batch shall comprise a maximum of 200 assembled screw couplers consisting of elements from the same batches or 200 pieces from single parts (without links) or 400 links.

F.8.3 Advice of submission for acceptance

Submission for acceptance shall take place in two stages, as follows:

- Submission of the component parts;
- Submission of the assembled screw couplings.

A record of the results of the individual hardness tests carried out on component parts shall also be provided at the time of submission for acceptance.

F.8.4 Nature and proportion of the tests

Unless otherwise specified in the technical specification, Table F.4 below lists the tests and checks to be carried out on each batch as well as the minimum corresponding proportions.

Table F.4 — Proportion of the tests – Finished products and component parts

Material or part	Nature of the checks	Minimum proportion of the tests and checks
All component parts	Appearance and condition	100 % of the parts
	Dimensions	10 % of the parts
Coupler screw, shackles, links, pins	Chemical analysis	1 per casting ^a
	Macrographic and micrographic examination	1 per casting ^c
	Tensile test on specimen taken from the parts in the delivery condition (except links)	1 per batch
	Impact strength on V-notched specimens (test on two specimens taken on the parts) ^b	1 series per batch
	Brinell hardness	100 % of the parts
Trunnion nuts	Chemical analysis	1 per casting ^a
	Macrographic and micrographic examination	1 per casting ^c
	Impact strength on V-notched specimens (test on two specimens taken on the parts) ^b	1 series per batch
	Brinell hardness on the surface	100 % of the parts
	Brinell hardness in the core	1 per batch
Screw couplings complete	Tensile test with half minimum breaking load, minimum and maximum breaking load	1 per batch
Links	Tensile fracture test	1 per batch
^a The analysis on the parts may be dropped if already carried out on the material by the manufacturer of the parts. ^b If the specimens are taken from parts prior to the tensile test under minimum breaking load, they shall undergo the reference treatment specified on delivery before the impact test. ^c If not otherwise defined in the technical specification.		

F.8.5 Sampling and preparation of the samples and test pieces

F.8.5.1 Sampling

The macrographic examinations, the chemical analyses and impact test on screws may be carried out on parts of the assembled screw coupling which have undergone the tensile test.

F.8.5.2 Preparation of the samples and test pieces

Failing any indication to the contrary, the samples and test pieces shall be prepared in accordance with the provisions of EN ISO 377.

Figure F.5 to Figure F.10 indicate the position of the tensile test and impact strength specimens and the macrographic slides as well as those intended for hardness measurements.

a) Hardness

Hardness tests shall be carried out on the samples and test pieces themselves, the area chosen to receive the impressions being machined or ground to a depth of about 2 mm.

b) Notched bar impact test

Two standard Charpy V-notch test pieces shall be cut from the positions defined in Figure F.5 to Figure F.10, which also show the orientation of the notch.

Machining of the test pieces shall be carried out in accordance with the indications of EN ISO 148-1.

c) Micrographic and macrographic examinations

The sections to be examined, for each category of component, are those whose position is defined in Figure F.5 to Figure F.10. The surface of these sections shall be carefully machined, polished and degreased.

d) Chemical analysis

The sample for chemical analysis shall consist, in principle, of a small plate of full section, weighing at least 50 g, cut parallel to the section intended for the macrographic examination (see Figure F.5 to Figure F.10).

e) Tensile strength

The machining of the specimens shall be performed as indicated in EN ISO 377.

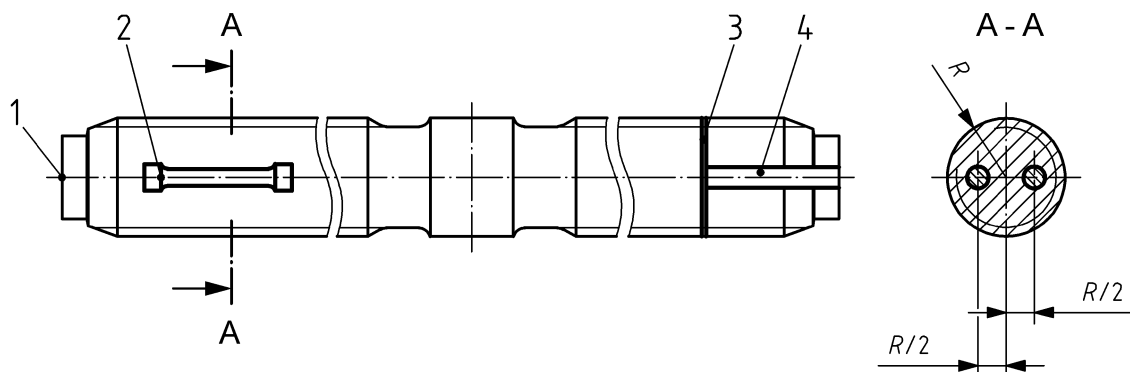

Key

- 1 position of Brinell hardness test
- 2 tensile strength specimens
- 3 sample for macrographic and micrographic test
- 4 sample for impact test

Figure F.5 — Screw - test sample location

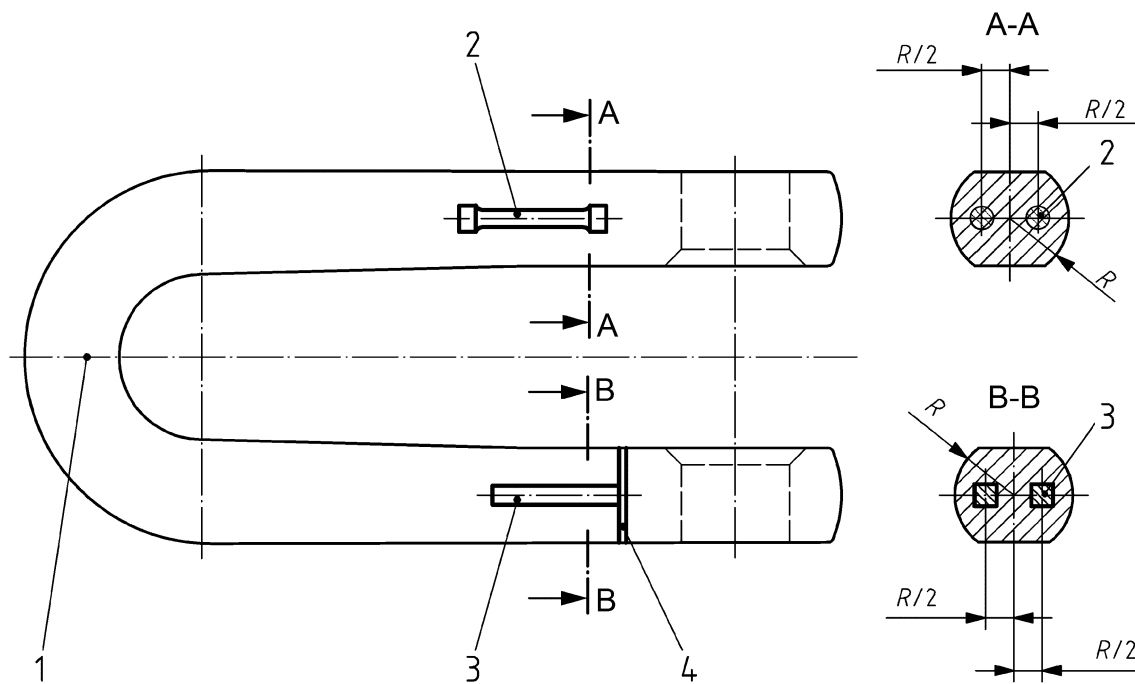

Key

- 1 position of Brinell hardness test
- 2 tensile strength specimens
- 3 sample for impact test
- 4 sample for macrographic and micrographic test

Figure F.6 — Shackle - test sample location

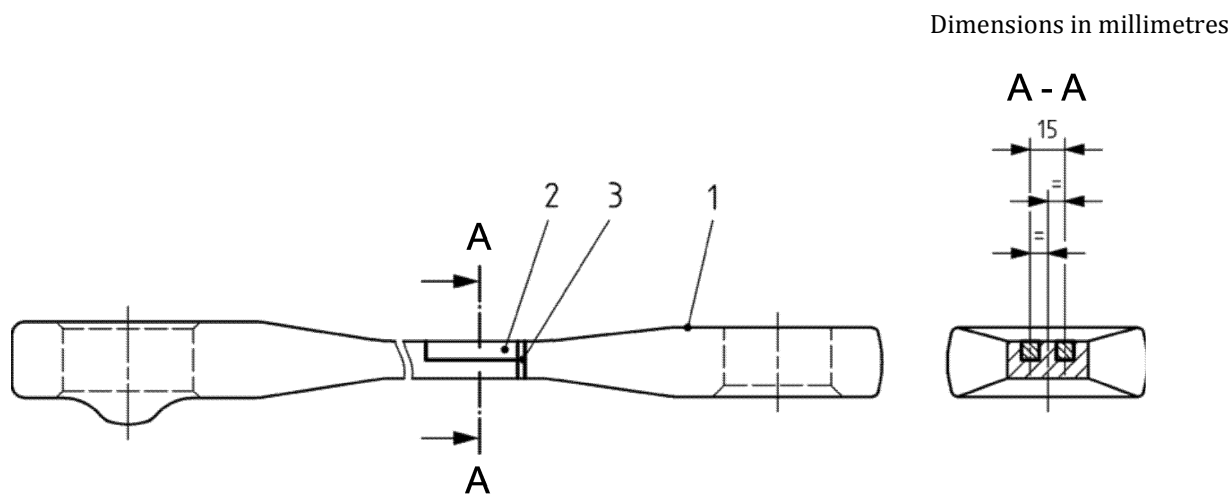

Key

- 1 position of Brinell hardness test
- 2 sample for impact test
- 3 sample for macrographic and micrographic test

Figure F.7 — Coupling link - test sample location

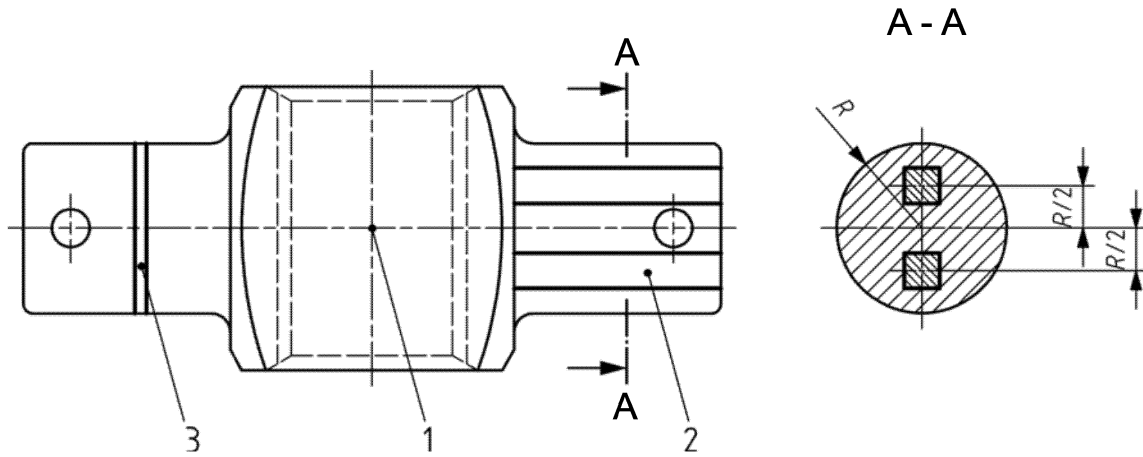

Key

- 1 position of Brinell hardness test
- 2 sample for impact test
- 3 sample for macrographic and micrographic test

Figure F.8 — Trunnion nut (link fitting) - test sample location

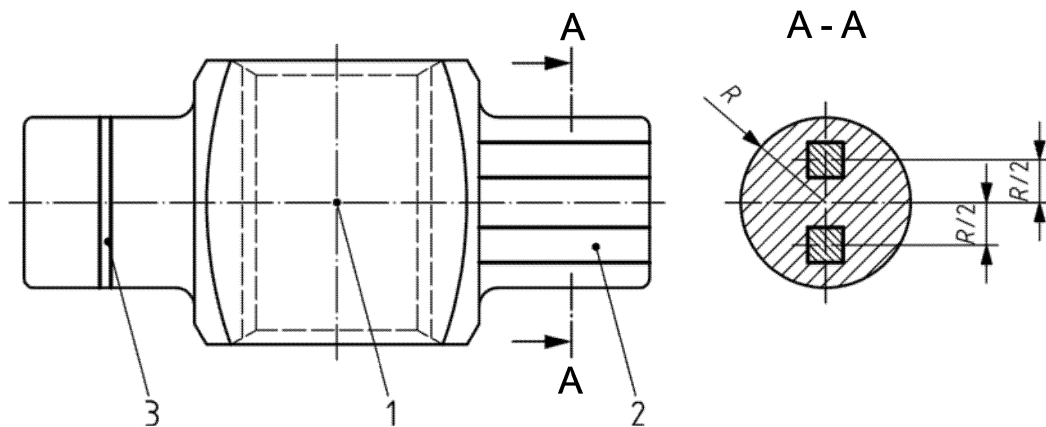

Key

- 1 position of Brinell hardness test
- 2 sample for impact test
- 3 sample for macrographic and micrographic test

Figure F.9 — Trunnion nut (shackle fitting) - test sample location

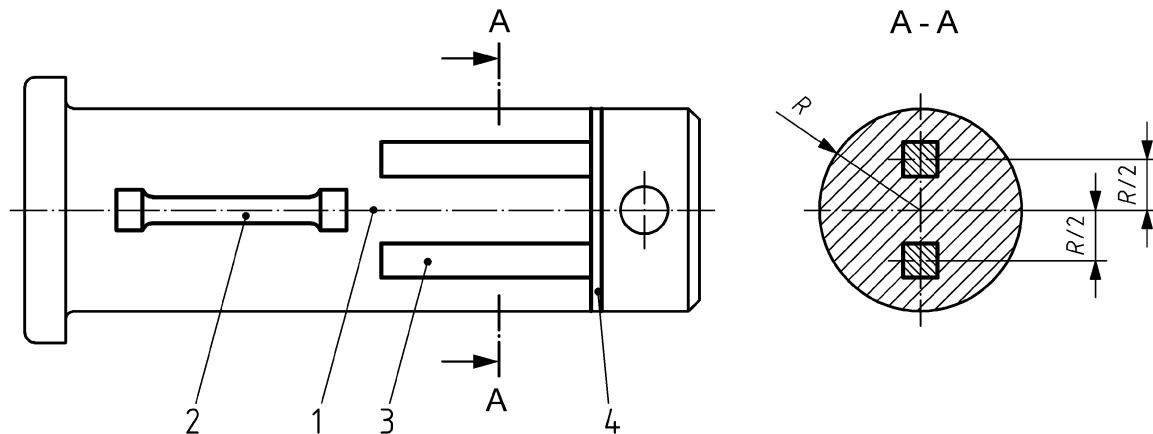

Key

- 1 position of Brinell hardness test
- 2 tensile strength specimens
- 3 sample for impact test
- 4 sample for macrographic and micrographic test

Figure F.10 — Pin - test sample location

F.8.6 Carrying out of the checks and tests

F.8.6.1 Materials

The checks and tests shall be carried out in accordance with the provisions in the technical specification.

If no reference is made to any other document, the tests shall be carried out in accordance with the indications of the following documents:

Tensile test for the steel EN ISO 6892-1 to 2;

Charpy resilience test EN ISO 148-1 to 3;

F.8.6.2 Component parts

F.8.6.2.1 Checking the dimensions

The dimensional check on the parts shall be carried out by any suitable means, particularly with the aid of manufacturer's gauges.

The accuracy of the threads on screws and in trunnions shall be checked by means of limit gauges.

F.8.6.2.2 Soundness of the parts

The surface conditions, particularly the regularity of the connecting radii of both as-forged and machined parts, shall be examined.

If there is any doubt, additional methods of investigation: dye penetrant, magnetic particle examination, etc. shall be applied.

F.8.6.2.3 Hardness test

The hardness test shall be carried out in accordance with the provisions of EN ISO 6506-1: Brinell hardness test.

F.8.6.2.4 Notched bar impact test

The impact test made on V-notch Charpy test pieces shall be carried out in accordance with EN ISO 148-1.

Neither of the two test pieces shall give a result lower than the prescribed value.

F.8.6.2.5 Chemical composition

The results of chemical analysis for the various elements shall be in accordance with the material indicated on the drawings.

F.8.6.2.6 Coupling link fracture test

The tensile test shall be performed using appropriate apparatus to ensure that the coupling link to be tested is subjected to the same tensile forces as in a standard screw coupling.

F.8.6.3 Screw couplings

F.8.6.3.1 Preparation of the test

The screw couplings assembled for the tensile test shall be set up so that the trunnion nuts are about 55 mm from the ends of the screw as shown in Figure F.1.

They shall then be marked out in accordance with the indications in Figure F.1. If it is found easier to do so, the marks may be applied after placing of the screw coupling on the tensile machine.

The screw coupling shall then be secured in the tensile machine by means of loading attachments, the shape and dimensions of which are in accordance with those of Figure F.2.

The screw coupling shall be subjected to an initial tension of 35 kN. Dimensions a , b , c , d , e , f and g (see Figure F.1) shall be measured and noted.

F.8.6.3.2 Test under half minimum breaking load

The tensile load shall be gradually increased up to a load equivalent to half minimum breaking load or as little in excess of that figure as possible and this shall be maintained for at least 1 min before the force is reduced to its initial value of 35 kN. The dimensions a , b , c , d , e , f and g (see Figure F.1) then recorded shall not reveal any permanent deformation greater than that indicated in F.4.5.1.

F.8.6.3.3 Test under minimum breaking load

The tensile load shall again be gradually increased up to the 95 % of minimum breaking load or as little in excess of that figure as possible and this shall be maintained for 3 min and then released. The screw coupling shall then be examined. For results see F.4.5.2.

F.8.6.3.4 Test under maximum breaking load

The tensile load shall again be increased until fracture. The maximum breaking force of the Table 1 shall not be exceeded.

F.9 Completion of inspections

Any defect in appearance or any dimensional error unacceptable for satisfactory use observed on a screw coupling shall result in its rejection.

Any result not in accordance with one of the other tests shall result in rejection of the corresponding batch.

F.10 Delivery

F.10.1 Protection against oxidation

After inspection and stamping as agreed in the technical specification and before storage or despatch, the screw couplings shall receive an anti-rust coating as agreed in the technical specification, on the machined parts.

F.10.2 Packing

The parts shall be carefully protected by suitable packing with a view to avoiding any deterioration, especially of the machined parts, or deformation during handling or transit.

Annex G
(normative)

Elastic device – Requirements

G.1 Rubber elastomer or other elastomer elastic device

G.1.1 General

This clause concerns rubber elastomer or other elastomer elastic systems in which inserts may be present.

G.1.2 Metal inserts requirements

Unless otherwise specified, minimum steel grade is S 235 JR according to the EN 10025 series.

Surface state, dimensions and rust protection are made according to technical specification.

G.1.3 Elastomer requirements

Composition, characteristics and process are made according to technical specification in accordance with Table G.1.

The approval values in Table G.1 are the average of the tests done during the type test (Table G.2).

The maximum static absorbed and stored capacity deviations are 20 % compared to the type test.

Table G.1 — Characteristics of the constituents

Characteristics	Results	Tests for rubber elastomer	Tests for others
Hardness <i>IRHD</i> according to ISO 48	$D_i =$ approval initial hardness $D_p =$ piece hardness $D_a =$ after ageing 7 days at a temperature of 70 °C $D_p = D_i \pm 5 \text{ IRHD}$ $\Delta D = D_a - D_p \leq 8 \text{ IRHD}$	x	
Tensile strength <i>R</i> according to ISO 37	$R_i =$ approval value $R_p =$ piece value $R_a =$ after ageing 7 days at a temperature of 70 °C $R_p = R_i \pm 0,15 R_i$ $\frac{\Delta R}{R_p} = \frac{ R_a - R_p }{R_p} \leq 0,2$	x	
Elongation at fracture <i>A</i>	$A_i =$ approval value	x	

Characteristics	Results	Tests for rubber elastomer	Tests for others
according to ISO 37	A_p = piece value A_a = after ageing 7 days at a temperature of 70°C $A_p = A_i \pm 0,15 A_i$ $\frac{\Delta A}{A_p} = \frac{ A_a - A_p }{A_p} \leq 0,25$		
200 % Elongation modulus M according to ISO 37	M_i = approval value M_p = piece value M_a = after ageing 7 days at a temperature of 70 °C $M_p = M_i \pm 0,15 M_i$ $\frac{\Delta R}{M_p} = \frac{ M_a - M_p }{M_p} \leq 0,2$	x	
Stress Relaxation 25 % during 24 h at 70 °C according to ISO 815-1	$DRC \leq 25 \%$	x	
Compression set after 25 % compression for 24 h at -30 °C measured after stabilizing for 3 min. at -30 °C according to ISO 815-2 (measurement at ambient temperature)	$DRC \leq 35 \%$	x	
Shore hardness D according to ISO 7619-1	D_i = approval initial hardness D_p = piece hardness $D_p = D_i \pm 5$ shore		x
Static characteristics after ageing 7 days at 70 °C according to ISO 188	WS_i = approval initial value of stored energy WS_p = piece value After ageing $WS_p = WS_i \pm 25 \%$ WA_i = approval initial value of absorbed energy WA_p = piece value $WA_p = WA_i \pm 25 \%$	x	

Characteristics	Results	Tests for rubber elastomer	Tests for others
Static characteristics after ageing 7 days at 50 °C according to ISO 188	WS_i = approval initial value of stored energy WS_p = piece value After ageing $WS_p = WS_i \pm 25 \%$ WA_i = approval initial value of absorbed energy WA_p = piece value $WA_p = WA_i \pm 25 \%$		x

G.1.4 Static test

G.1.4.1 Test principle

The test consists of the determination of the force-stroke diagram during the compression of the constituent. This test is carried out on a complete system constituted to the elastic system to be tested and/or a guiding gauge representative of the preset height.

G.1.4.2 Test procedure

For rubber elastomer systems, tests have to be carried out at least 72 h after assembly.

Test temperature shall be between 15 °C and 25 °C.

Three cycles up to the maximum stroke are made; the second and third cycles shall follow immediately after the first. The tests shall be arranged in such a way that the elastic system will not be exposed to any inadmissible thermal loads.

For this reason, time periods between two complete cycles are permitted but they shall not exceed 10 min.

The compression phase shall be followed immediately by the decompression phase, and the maximum displacement speed of the testing device in both directions shall be 0,05 m/s.

G.1.4.3 Measurements

Measurements are the following:

- Stroke of the assembly;
- Force.

Parameters are recorded on a diagram stroke-force with a calibrated press. Stored energy W_e and absorbed energy W_a are calculated with the diagram. Speed of the cycle and temperature during the test are also recorded.

The maximum static absorbed capacity deviation is 20 % compared to the approval static value, the elastomer shall not overlap the metals and there shall be no critical cracks after visual inspection.

G.1.5 Endurance test

After the tests the elastomer surface shall show no breaks, defects, signs of cracking or abrasions over 2 mm in depth.

The flexibility test, repeated on the assembled spring after the endurance test, shall give results which comply with the specifications given on the drawing.

During and after the endurance test, energy absorption shall remain within the limits laid down on the drawing.

A complete set is mounted in a machine that operates automatically. The load frequency shall be chosen in such a way that the temperature of the set does not exceed a temperature which may cause problems (any air cooling system is allowed).

Failing any indication to the contrary, a frequency of six cycles per minute shall be adopted.

The test shall be carried out according to the following load cycles (see Figures G.1 and G.2):

- 10 000 loadings between [preset height $H_1 - (0,25 \text{ stroke} \pm 2)$] mm and [preset height $H_1 - (0,60 \text{ stroke} \pm 2)$] mm.
- After 24 h of applying no load on the free set (without any presetting load), the load to be applied to achieve the preset height has to be greater than or equal to 10 kN.
- In the same condition, after a completion of the static set the energies (W_e and W_a) have to be greater than or equal to 80 % of the initial values.

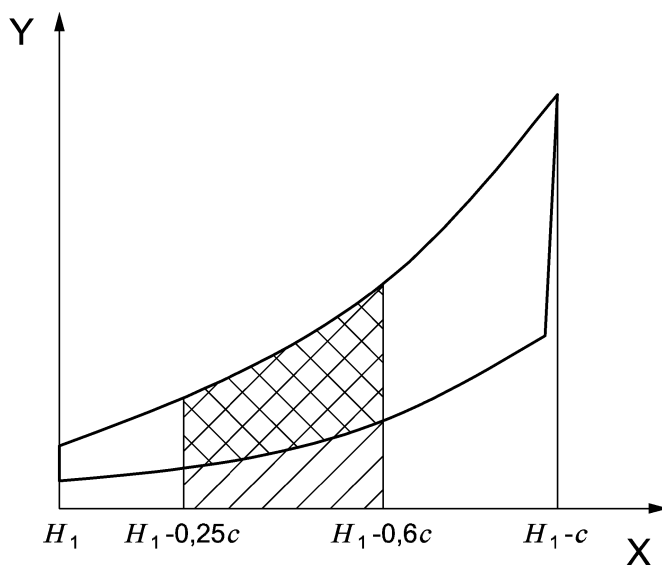

Key



- Y force [k]
X stroke [mm]
H height of elastic device
c stroke of elastic device
 H_1 preset height of the elastic system without stress
 stored energy W_e in kJ
 absorbed energy W_a in kJ

Figure G.1 — Elastic device – load cycle for endurance test



Key

- c stroke of elastic device
- H_0 initial height of elastic system
- H_1 preset height of the elastic system without stress

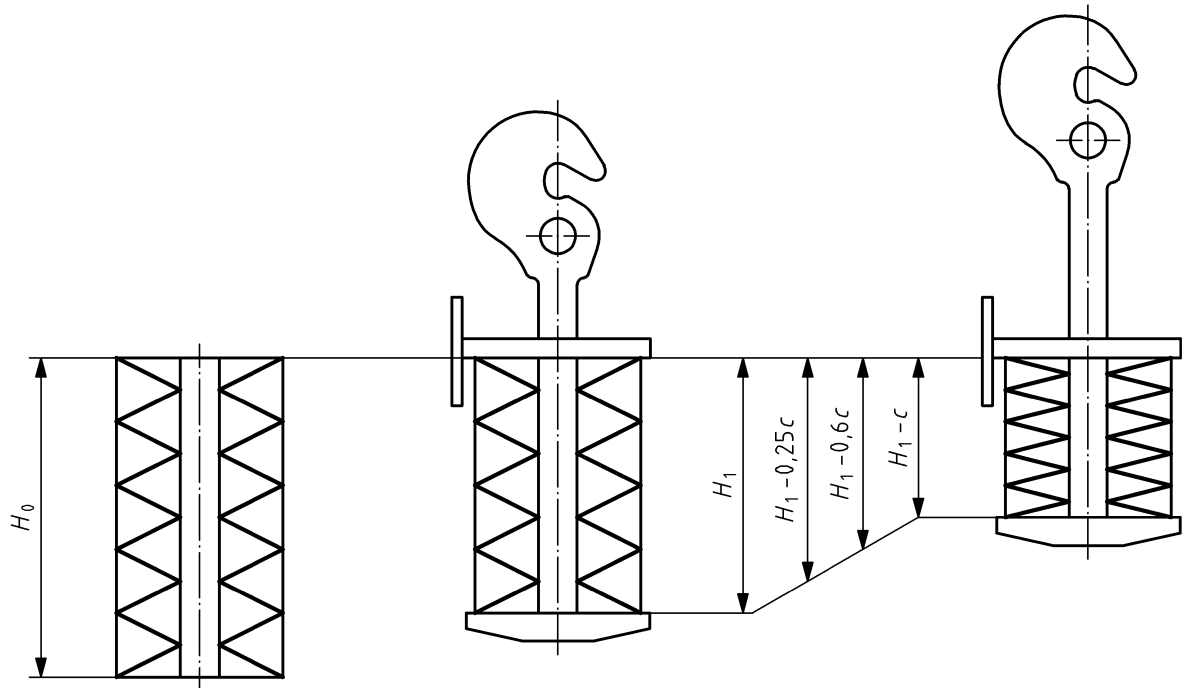
Figure G.2 — Elastic device - Set up for endurance test

G.1.6 Bonding

If applicable, test procedures or requirements have to be defined in accordance with ISO 813 in the technical specification.

G.1.7 Inspection and Tests

A batch is a group of component parts of the type, originating from the same melt of raw material and having undergone the same process of manufacturing.

The quantity of series tests shall be a minimum of one or as defined in the technical specification for a batch comprising less than 40 component parts.

The number of the approval or production tests shall be in accordance with Table G.2.

Table G.2 — Nature of inspections and tests

Nature of inspections and tests (if applicable)	approval		Production series	
	Level	Number of tests	Level	Number of tests
Spring element without ageing:				
Dimensions	M	2	M	2,5 % per batch
Bonding	M	2	M	2,5 % per batch
Hardness <i>IRHD</i> / Shore <i>D</i>	M	2	M	2,5 % per batch
Tests (<i>R,A,M</i>)	M	2	M	1/batch
Compression set (25 %, 50°C/70°C)	M	2		
Compression set (25 %, -30°C)	M	2		
Spring element after ageing:				
Dimensions	M	2	O	2,5 % per batch
Bonding	M	2	O	2,5 % per batch
Hardness <i>IRHD</i> / Shore <i>D</i>	M	2	O	2,5 % per batch
Tests (<i>R,A,M</i>)	M	2	O	1 per batch
Compression set (25 %, 50°C/70°C)	M	2		
Compression set (25 %, -30°C)	M	2		
Metals:				
Dimensions	M	1	M	5 per batch
Chemical composition	M	1	M	1 per cast
Spring set:				
Dimensions	M	1	M	2,5 % per batch
Static test	M	1	M	1 per batch
Endurance test	M	1	O	
Spring set after ageing:				
Static test	M	1	O	
Endurance test	O	1	O	
Key for level: M: mandatory test O: optional test				

G.1.8 Markings

Unless otherwise specified, the following indications shall appear:

- manufacturer's stamp;

- batch number or serial number or month and the last two figures of the manufacturing year.

G.2 Friction spring/Ring spring

G.2.1 Manufacturer's marks

- Rings shall be marked as specified in the technical specification;
- in the absence of specifications in the documents (technical specification), the rings shall show the year of manufacture;
- however, when rings are manufactured by rolling, these marks may be replaced by a circular line or groove marked during the rolling process on a curved surface, the shape and position of which will indicate the above information in a conventional code.

G.2.2 Flexibility test

G.2.2.1 Requirements for flexibility test

- the height H_1 shall be within tolerances specified in the supplier's drawing;
- during the initial cycle of operations the loads in proportions to the deflection shall comply with the specifications of the graph shown on the drawing, allowing for the tolerances provided;
- after 20 compression and release cycles, the new loads recorded, in proportion to the deflection shall comply with the specifications of the graph shown on the drawing, allowing for the tolerances provided;
- after 20 compression and release cycles, the new loads recorded, in proportion to the deflection, shall remain within the same tolerance.
- After tests the rings should show no breaks, defects, signs of cracking or abrasions.

G.2.2.2 Carrying out of the flexibility test

- The flexibility test shall be carried out as follows: the slightly greased rings are stacked in such a way as to form a spring as used in service;
- The stack thus formed is tested as indicated below on a test bench equipped with a chart recording device. The test bench shall be checked at least once a year by an independent body:
 - The spring is compressed three times up to the maximum stroke as shown on the drawing and the load maintained, each time, for 1 min up to this stroke;
 - The semi-static diagram is recorded. It shall comply with the specifications of the drawing, with allowance for the tolerances;
 - The spring is compressed 20 times to the maximum stroke indicated on the drawing and the load maintained, each time, for 30 s, up to this stroke;
 - The semi-static diagram is recorded. It shall comply with the specifications of the drawing, with allowance for the tolerances.

G.2.2.3 Number of tests

Each batch when submitted shall be subjected to inspections and tests of type and number indicated in Table G.3.

Table G.3 — Number of flexibility tests per batch of springs

Batch size	Number of tests
Up to 50	1
51 to 150	2
151 to 300	3
301 to 500	4
501 to 1 000	5

G.2.3 Endurance test

- The test shall use a normally lubricated spring, mounted in a casing or similar device;
- after the tests the rings shall show no breaks, defects, signs of cracking or abrasions;
- the flexibility test, repeated on the assembled spring after the endurance test, shall give results which comply with the specifications given on the drawing;
- during and after the endurance test, energy absorption shall remain within the limits laid down on the drawing;
- the load frequency shall be chosen in such a way that the temperature of the rings does not exceed 60 °C;
- to ensure that the quality meets the required standards, the test shall be carried out with 5 000 loadings at 85 % of the nominal absorption load;
- when this test has been completed, the value for the absorption load shall not exceed the specified limits;
- this test is only carried out if specifically stated in the technical specification.

Annex H (normative)

Marking

H.1 General

The draw hooks and the draw bars shall be stamped with the type of marks and in the position specified in the technical specification.

As a minimum, each part shall be stamped with the following marks:

- manufacturer's mark;
- batch number including the last two figures of the year of manufacture;
- leave an appropriate space on the draw hook and the draw bar for a possible request for marking by the ownership (stamped mark);
- identification mark;
- the minimum breaking load for coupling system of categories 1,2 MN and 1,5 MN.

The position and the type of the marking shall not affect the safety of the draw hook and draw bar.

It is recommended that the marks are embossed by hot-working during the forging or die-forging operation.

Draw gear with a higher minimum breaking load has to be marked to enable clear identification if mounted, for instance by hot stamping "1,5" upon the surface.

H.2 Marking of the screw coupling

The screws, shackles, trunnion nuts, links and pins shall bear the following marks:

- the manufacturer's mark;
- the date of manufacture (last two figures of the year of manufacture);
- mark of ownership (only for the handle if required in the technical specification);
- special marking depending on the coupling system classification according Table H.1.

The characteristic marks are located as shown in the Figure H.1.

The minimum dimensions for the mark are shown in the Figure H.2.

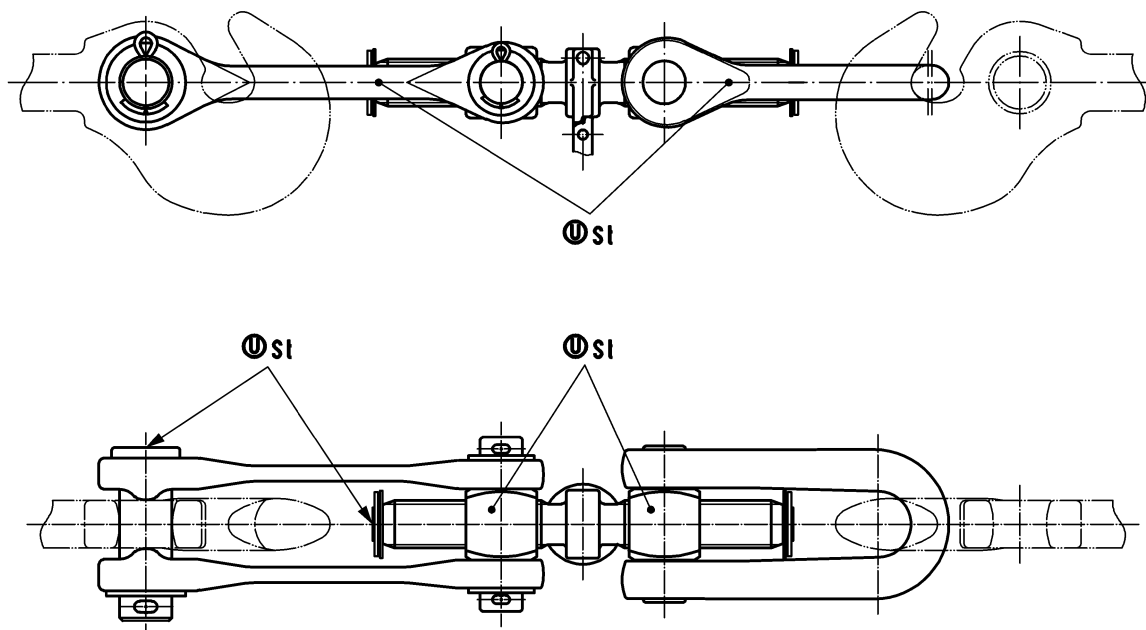

Figure H.1 — Location of mark

Dimensions in millimetres

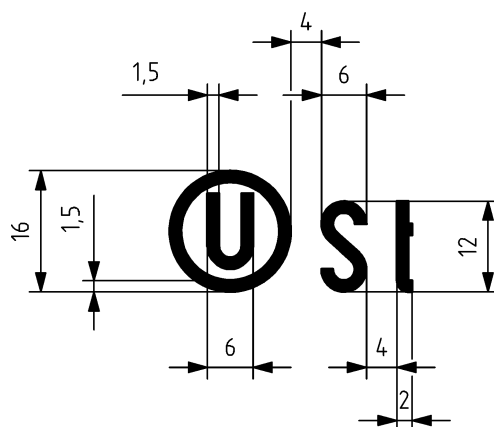

Figure H.2 — Mark dimension

In the case of forged parts, the marks shall be embossed when hot, during the stamping operation. In the case of the screws and exceptionally the trunnion nuts and pins, the marks may be applied when cold by means of rounded-edge stamps at the end of the screws, trunnions or pins.

H.3 Draw gear

If required in the technical specification, markings of the complete draw gear shall be at least those listed in the Table H.1.

H.4 Draw bar

Markings of the draw bar shall be at least those listed in the Table H.1.

H.5 Summary of markings

The Table H.1 gives a summary of markings for the component parts.

Table H.1 — Marking

		Marking for minimum breaking load	Comment
Draw hook			
Draw hook, 1 MN	X	—	
Draw hook, 1,2 MN	X	1,2	permitted: 120 t or 1 200 kN
Draw hook, 1,5 MN	X	1,5	permitted: 150 t or 1 500 kN
Screw coupling			
Screw, shackle, links, nuts, pin, according to the 1 MN ERRI-drawings	X	St	
Screw, shackle, links, nuts, pin, 1 MN	X	—	
Screw, shackle, links, nuts, pin, 1,2 MN	X	1,2	permitted: 120 t or 1 200 kN
Screw, shackle, links, nuts, pin, 1,5 MN	X	1,5	permitted: 150 t or 1 500 kN
Draw gear for freight wagons (completely)			
Draw gear, 1 MN	X	—	
Draw gear, 1,2 MN	X	1,2	permitted: 120 t or 1 200 kN
Draw gear, 1,5 MN	X	1,5	permitted: 150 t or 1 500 kN
Draw gear for other vehicles (completely)			
Draw gear, 1 MN	—	—	
Draw gear, 1,2 MN	—	1,2	permitted: 120 t or 1 200 kN
Draw gear, 1,5 MN	—	1,5	permitted: 150 t or 1 500 kN
Draw bar			
Draw bar, 1 MN	—	—	
Draw bar, 1,2 MN	—	1,2	permitted: 120 t or 1 200 kN
Draw bar, 1,5 MN	—	1,5	permitted: 150 t or 1 500 kN

Annex ZA
(informative)

Relationship between this European Standard and the Essential Requirements of EU Directive 2008/57/EC

This European Standard has been prepared under a mandate given to CEN/CENELEC/ETSI by the European Commission and the European Free Trade Association to provide a means of conforming to Essential Requirements of the Directive 2008/57/EC.

Once this standard is cited in the Official Journal of the European Union under that Directive and has been implemented as a national standard in at least one Member State, compliance with the clauses of this standard given in Table ZA.1 for Infrastructure and Table ZA.2 for Locomotives and Passenger Rolling Stock confers, within the limits of the scope of this standard, a presumption of conformity with the corresponding Essential Requirements of that Directive and associated EFTA regulations

Table ZA.1 — Correspondence between this European Standard, the Commission Regulation concerning the technical specification for interoperability relating to the subsystem ‘rolling stock – freight wagons’ of the rail system in the European Union and repealing Commission Decision 321/2013/EC, as amended by Commission Regulation (EU) 2015/924 (published in the Official Journal L 150, 17.06.2015, p.10); and Directive 2016/797/EC

Clause/ subclauses of this European Standard	Chapter/§/annexes of the TSI	Corresponding text, articles/§/annexes of the Directive 2008/57/EC	Comments
The whole standard is applicable	4 Characterization of the subsystem 4.2 Functional and technical specifications of the subsystem 4.2.2 Structures and mechanical parts 4.2.2.1 Mechanical interface § 4.2.2.1.1 End coupling § 4.2.2.1.2 Inner coupling Appendix C Additional optional conditions 1. Manual coupling system Appendix D Standards or normative documents referred to in this TSI Additional optional conditions for units Manual coupling system	Annex III, Essential requirements 1 General requirements 1.1 Safety Clauses 1.1.1, 1.1.3, 1.1.5 2 Requirements specific to each subsystem 2.4 Rolling stock 2.4.2 Reliability and availability	The EN is referenced in Appendix C of the TSI The reference in Appendix D of the TSI to the EN refers to the 2010 version; the updated text in this version remains valid.

Table ZA.2 — Correspondence between this European Standard, the Commission regulation (EU) No 1302/2014 of 18 November 2014 concerning the technical specification for interoperability relating to the ‘rolling stock locomotives and passenger rolling stock’ of the rail system in the European Union (published in the Official Journal L 356, 12.12.2014, p.228) and Directive 2008/57/EC

Clause/ subclauses of this European Standard	Chapter/§/annexes of the TSI	Corresponding text, articles/§/annexes of the Directive 2008/57/EC	Comments
The whole standard is applicable	4 Characteristics of the Rolling stock subsystem 4.2 Functional and technical specification of the sub-system 4.2.2 Structure and mechanical parts 4.2.2.2 Mechanical interfaces § 4.2.2.2.1 General and definitions § 4.2.2.2.2 Inner coupling § 4.2.2.2.3 End coupling § 4.2.2.2.4 Rescue coupling 5 Interoperability constituents 5.3 Interoperability constituent specification § 5.3.2 Manual end coupling Appendix A Buffers and screw coupling system A.2 Screw coupling A.3 Interaction of draw and buffing gear Appendix J Technical specifications referred to in this TSI J-1 Standards or normative documents Index 68	Annex III, Essential requirements 1 General requirements 1.1 Safety Clauses 1.1.1, 1.1.3, 1.1.5 2 Requirements specific to each subsystem 2.4 Rolling stock 2.4.1 Safety §1 2.4.2 Reliability and availability	The TSI cites the UIC type of manual end coupling described in this EN as an Interoperability Constituent. The TSI also cites the EN as a means of achieving the requirements for a UIC-type manual end coupling. The reference in Appendix J of the TSI to the EN refers to the 2010 version; the updated text in this version remains valid.

WARNING — Other requirements and other EC Directives may be applicable to the product(s) falling within the scope of this standard.

Bibliography

- [1] EN 15085-1, *Railway applications — Welding of railway vehicles and components — Part 1: General*
- [2] EN 15085-2, *Railway applications - Welding of railway vehicles and components - Part 2: Quality requirements and certification of welding manufacturer*
- [3] EN 15085-3, *Railway applications - Welding of railway vehicles and components - Part 3: Design requirements*
- [4] EN 15085-4, *Railway applications - Welding of railway vehicles and components - Part 4: Production requirements*
- [5] EN 15085-5, *Railway applications - Welding of railway vehicles and components - Part 5: Inspection, testing and documentation*
- [6] EN 15020, *Railway applications — Rescue coupler — Performance requirements, specific interface geometry and test methods*
- [7] EN 15839, *Railway Applications — Testing for the acceptance of running characteristics of railway vehicles — Freight wagons — Testing of running safety under longitudinal compressive forces*
- [8] prEN 16839, *Railway applications — Rolling stock — Head stock layout*
- [9] EN ISO 286-1, *Geometrical product specifications (GPS) - ISO code system for tolerances on linear sizes - Part 1: Basis of tolerances, deviations and fits (ISO 286-1)*
- [10] UIC 520, *Wagons, coaches and vans — Draw gear — Standardisation*
- [11] UIC 825, *Technical specification for the supply of draw hooks with nominal load equal to 250 kN, 600 kN or 1000 kN for tractive and trailing stock*
- [12] UIC 826, *Technical specification for the supply of screw couplings for tractive and trailing stock*
- [13] UIC 827-1, *Technical specification for the supply of elastomer components for buffers*
- [14] UIC 827-2, *Technical specification for the supply of steel rings for buffer springs*
- [15] ERRI Report B 51/RP 27:1995-07-01, *Buffering and Drawgear — Design and testing of new drawgear for wagons*²⁾
- [16] ERRI, standard drawings 100M 3220 0001, 100M 3220 0002 and 100M 3211 0001²⁾
- [17] RP 32 of ORE B 36, *Characteristics of the buffing and draw gear of wagons to ensure the safe running of long vehicles in small radius curves*²⁾

²⁾ To be purchased from UIC.

British Standards Institution (BSI)

BSI is the national body responsible for preparing British Standards and other standards-related publications, information and services.

BSI is incorporated by Royal Charter. British Standards and other standardization products are published by BSI Standards Limited.

About us

We bring together business, industry, government, consumers, innovators and others to shape their combined experience and expertise into standards-based solutions.

The knowledge embodied in our standards has been carefully assembled in a dependable format and refined through our open consultation process. Organizations of all sizes and across all sectors choose standards to help them achieve their goals.

Information on standards

We can provide you with the knowledge that your organization needs to succeed. Find out more about British Standards by visiting our website at bsigroup.com/standards or contacting our Customer Services team or Knowledge Centre.

Buying standards

You can buy and download PDF versions of BSI publications, including British and adopted European and international standards, through our website at bsigroup.com/shop, where hard copies can also be purchased.

If you need international and foreign standards from other Standards Development Organizations, hard copies can be ordered from our Customer Services team.

Copyright in BSI publications

All the content in BSI publications, including British Standards, is the property of and copyrighted by BSI or some person or entity that owns copyright in the information used (such as the international standardization bodies) and has formally licensed such information to BSI for commercial publication and use.

Save for the provisions below, you may not transfer, share or disseminate any portion of the standard to any other person. You may not adapt, distribute, commercially exploit, or publicly display the standard or any portion thereof in any manner whatsoever without BSI's prior written consent.

Storing and using standards

Standards purchased in soft copy format:

- A British Standard purchased in soft copy format is licensed to a sole named user for personal or internal company use only.
- The standard may be stored on more than 1 device provided that it is accessible by the sole named user only and that only 1 copy is accessed at any one time.
- A single paper copy may be printed for personal or internal company use only.

Standards purchased in hard copy format:

- A British Standard purchased in hard copy format is for personal or internal company use only.
- It may not be further reproduced – in any format – to create an additional copy. This includes scanning of the document.

If you need more than 1 copy of the document, or if you wish to share the document on an internal network, you can save money by choosing a subscription product (see 'Subscriptions').

Reproducing extracts

For permission to reproduce content from BSI publications contact the BSI Copyright & Licensing team.

Subscriptions

Our range of subscription services are designed to make using standards easier for you. For further information on our subscription products go to bsigroup.com/subscriptions.

With **British Standards Online (BSOL)** you'll have instant access to over 55,000 British and adopted European and international standards from your desktop. It's available 24/7 and is refreshed daily so you'll always be up to date.

You can keep in touch with standards developments and receive substantial discounts on the purchase price of standards, both in single copy and subscription format, by becoming a **BSI Subscribing Member**.

PLUS is an updating service exclusive to BSI Subscribing Members. You will automatically receive the latest hard copy of your standards when they're revised or replaced.

To find out more about becoming a BSI Subscribing Member and the benefits of membership, please visit bsigroup.com/shop.

With a **Multi-User Network Licence (MUNL)** you are able to host standards publications on your intranet. Licences can cover as few or as many users as you wish. With updates supplied as soon as they're available, you can be sure your documentation is current. For further information, email subscriptions@bsigroup.com.

Revisions

Our British Standards and other publications are updated by amendment or revision.

We continually improve the quality of our products and services to benefit your business. If you find an inaccuracy or ambiguity within a British Standard or other BSI publication please inform the Knowledge Centre.

Useful Contacts

Customer Services

Tel: +44 345 086 9001

Email (orders): orders@bsigroup.com

Email (enquiries): cservices@bsigroup.com

Subscriptions

Tel: +44 345 086 9001

Email: subscriptions@bsigroup.com

Knowledge Centre

Tel: +44 20 8996 7004

Email: knowledgecentre@bsigroup.com

Copyright & Licensing

Tel: +44 20 8996 7070

Email: copyright@bsigroup.com

BSI Group Headquarters

389 Chiswick High Road London W4 4AL UK