

BS EN 15531-1:2015



BSI Standards Publication

Public transport — Service interface for real-time information relating to public transport operations

Part 1: Context and framework

bsi.

...making excellence a habit.™

National foreword

This British Standard is the UK implementation of EN 15531-1:2015. It supersedes DD CEN/TS 15531-1:2007 which is withdrawn.

The UK participation in its preparation was entrusted to Technical Committee EPL/278, Intelligent transport systems.

A list of organizations represented on this committee can be obtained on request to its secretary.

This publication does not purport to include all the necessary provisions of a contract. Users are responsible for its correct application.

© The British Standards Institution 2015. Published by BSI Standards Limited 2015

ISBN 978 0 580 83397 7

ICS 35.240.60

Compliance with a British Standard cannot confer immunity from legal obligations.

This British Standard was published under the authority of the Standards Policy and Strategy Committee on 31 August 2015.

Amendments issued since publication

Date	Text affected
------	---------------

EUROPEAN STANDARD

EN 15531-1

NORME EUROPÉENNE

EUROPÄISCHE NORM

August 2015

ICS 35.240.60

Supersedes CEN/TS 15531-1:2007

English Version

Public transport - Service interface for real-time information relating to public transport operations - Part 1: Context and framework

Transport public - Interface de service pour les informations en temps réel relatives aux opérations de transport public -
Partie 1 : Cadre et contexte

Öffentlicher Verkehr - Serviceschnittstelle für Echtzeitinformationen bezogen auf Operationen im öffentlichen Verkehr - Teil 1: Kontext und Grundstruktur

This European Standard was approved by CEN on 20 June 2015.

CEN members are bound to comply with the CEN/CENELEC Internal Regulations which stipulate the conditions for giving this European Standard the status of a national standard without any alteration. Up-to-date lists and bibliographical references concerning such national standards may be obtained on application to the CEN-CENELEC Management Centre or to any CEN member.

This European Standard exists in three official versions (English, French, German). A version in any other language made by translation under the responsibility of a CEN member into its own language and notified to the CEN-CENELEC Management Centre has the same status as the official versions.

CEN members are the national standards bodies of Austria, Belgium, Bulgaria, Croatia, Cyprus, Czech Republic, Denmark, Estonia, Finland, Former Yugoslav Republic of Macedonia, France, Germany, Greece, Hungary, Iceland, Ireland, Italy, Latvia, Lithuania, Luxembourg, Malta, Netherlands, Norway, Poland, Portugal, Romania, Slovakia, Slovenia, Spain, Sweden, Switzerland, Turkey and United Kingdom.



EUROPEAN COMMITTEE FOR STANDARDIZATION
COMITÉ EUROPÉEN DE NORMALISATION
EUROPÄISCHES KOMITEE FÜR NORMUNG

CEN-CENELEC Management Centre: Avenue Marnix 17, B-1000 Brussels

Contents

Page

European foreword	4
Introduction	5
1 Scope	7
1.1 Interfaces specified by this standard	7
1.2 Use of the SIRI standard	9
1.3 Limitations on SIRI and possible future developments.....	10
2 Normative references	10
3 Terms and definitions	11
3.1 Transport related terms	11
3.2 Communications and software concepts	24
4 Symbols and abbreviations	33
5 Types of reference data used in SIRI.....	34
5.1 General.....	34
5.2 Date and time format	36
5.3 Location coordinate system	36
5.4 National language of text elements	37
5.5 Participant (information provider) identification	37
5.6 Participant pair identification (service participant pair code).....	37
5.7 Point and place references	38
5.8 Vehicle journey references	40
5.9 Line, and direction references.....	41
5.10 Stop sequence references and circular journeys	41
5.11 Schedule version references	43
5.12 Product category references	43
5.13 Vehicle feature references	47
5.14 Service features	48
5.15 Situation references	50
5.16 Summary of data reference scopes	50
5.17 Transmodel compliant models.....	51
5.18 Modelling vehicle journeys in SIRI.....	52
6 Notation	60
6.1 Representation of XML model elements in text.....	60
6.2 Representing relationships in SIRI	60
6.3 Notation for XML model structures of SIRI messages.....	60
6.4 Notation for diagrams	62
Annex A (informative) Checklist for Implementing SIRI.....	63
A.1 Usage of the DSRC application layer.....	63
A.2 Legal and commercial Issues.....	63
A.3 Functional aspects	63
A.4 Operational aspects	65
Annex B (informative) Business Context.....	67
B.1 Purpose of this section	67

B.2	Business model	68
B.3	Use of information in public transport	70
B.4	Use Cases for this standard	75
B.5	SIRI System Model	79
Annex C	(informative) Background and Mapping of Some Current Implementations to SIRI	84
C.1	Introduction	84
C.2	SIRI origins	84
C.3	Deployment Example – Berlin	87
C.4	Deployment Example – Hamburg	88
C.5	Deployment Example – West Yorkshire	88
C.6	Deployment Example – Czech Republic	89
C.7	Deployment Example – Copenhagen	90
C.8	Deployment example – Île-de-France	91
C.9	SIRI Equivalences	93
	Bibliography	94

European foreword

This document (EN 15531-1:2015) has been prepared by Technical Committee CEN/TC 278 “Intelligent transport systems”, the secretariat of which is held by NEN.

This European Standard shall be given the status of a national standard, either by publication of an identical text or by endorsement, at the latest by February 2016 and conflicting national standards shall be withdrawn at the latest by February 2016.

Attention is drawn to the possibility that some of the elements of this document may be the subject of patent rights. CEN [and/or CENELEC] shall not be held responsible for identifying any or all such patent rights.

This document supersedes CEN/TS 15531-1:2007.

SIRI (CEN/TS 15531-1:2007) has been a CEN Technical Specification since 2007 and has been widely used in Europe and elsewhere and proven its usefulness. This document proposes a revised version of SIRI as a CEN European Standard, and is currently submitted to the Formal Vote. The proposed revisions are minor enhancements arising from experience of the deployment of SIRI in many live systems. This document also clarifies the relationship of SIRI to NeTEx, the new CEN Technical Standard for the XML exchange of Public Transport Reference data based on the Transmodel CEN European Standard.

This document presents Part 1 of the European Standard known as “SIRI”. SIRI provides a framework for specifying communications and data exchange protocols for organizations wishing to exchange Real-time Information (RTI) relating to public transport operations.

The SIRI European Standard is presented in three parts:

- context and framework, including background, scope and role, normative references, terms and definitions, symbols and abbreviations, business context and use cases (Part 1),
- the mechanisms to be adopted for data exchange communications links (Part 2),
- data structures for a series of individual application interface modules PT, ET, ST, SM, VM, CT, CM, GM (Part 3).

Two additional parts define additional functional services as CEN Technical Specifications:

- additional data structures for additional application interface module FM (Part 4),
- additional data structures for additional application interface module SX (Part 5).

The XML schema can be downloaded from <http://www.siri.org.uk/>, along with available guidance on its use, example XML files, and case studies of national and local deployments.

It is recognized that SIRI is not complete as it stands, and from time to time will need to continue to be enhanced to add additional capabilities. It is therefore intended that a SIRI Management Group should continue to exist, at European level, based on the composition of SG7.

According to the CEN-CENELEC Internal Regulations, the national standards organizations of the following countries are bound to implement this European Standard: Austria, Belgium, Bulgaria, Croatia, Cyprus, Czech Republic, Denmark, Estonia, Finland, Former Yugoslav Republic of Macedonia, France, Germany, Greece, Hungary, Iceland, Ireland, Italy, Latvia, Lithuania, Luxembourg, Malta, Netherlands, Norway, Poland, Portugal, Romania, Slovakia, Slovenia, Spain, Sweden, Switzerland, Turkey and the United Kingdom.

Introduction

Public transport services rely increasingly on information systems to ensure reliable, efficient operation and widely accessible, accurate passenger information. These systems are used for a range of specific purposes: setting schedules and timetables; managing vehicle fleets; issuing tickets and receipts; providing real-time information on service running, and so on.

This European Standard specifies a Service Interface for Real-time Information (SIRI) about Public Transport. It is intended to be used to exchange information between servers containing real-time public transport vehicle or journey time data. These include the control centres of transport operators and information systems that utilize real-time vehicle information, for example, to deliver services such as travel information.

Well-defined, open interfaces have a crucial role in improving the economic and technical viability of Public Transport Information Systems of all kinds. Using standardized interfaces, systems can be implemented as discrete pluggable modules that can be chosen from a wide variety of suppliers in a competitive market, rather than as monolithic proprietary systems from a single supplier. Interfaces also allow the systematic automated testing of each functional module, vital for managing the complexity of increasing large and dynamic systems. Furthermore, individual functional modules can be replaced or evolved, without unexpected breakages of obscurely dependent function.

This European Standard will improve a number of features of public transport information and service management:

- Interoperability – the European Standard will facilitate interoperability between information processing systems of the transport operators by: (i) introducing common architectures for message exchange; (ii) introducing a modular set of compatible information services for real-time vehicle information; (iii) using common data models and schemas for the messages exchanged for each service; and (iv) introducing a consistent approach to data management.
- Improved operations management – the European Standard will assist in better vehicle management by (i) allowing the precise tracking of both local and roaming vehicles; (ii) providing data that can be used to improve performance, such as the measurement of schedule adherence; and (iii) allowing the distribution of schedule updates and other messages in real-time.
- Delivery of real-time information to end-users – the European Standard will assist the economic provision of improved data by: (i) enabling the gathering and exchange of real-time data between AVMS systems; (ii) providing standardized, well defined interfaces that can be used to deliver data to a wide variety of distribution channels. Version 2.0 of SIRI includes a new Simple Web Service designed to support the widespread, massively scalable use of mobile devices and web browsers and other applications to display public transport data directly to users.

Technical advantages include the following:

- Reusing a common communication layer for all the various technical services enables cost-effective implementations, and makes the European Standard readily extensible in future.

History

Version 1.0 of SIRI was developed in 2004-2005 and submitted to vote, eventually passing through the CEN process to become an approved CEN Technical Specification in 2007. As well as the normative Version 1.0 XSD schema, successive informal working versions of the schema (v 1.1 – 1.4) were released to allow for fixes and to implement some very minor enhancements agreed by the working group. A WSDL version was also developed.

Version 2.0 of SIRI was developed in 2012 to coincide with making the SIRI standard a full CEN norm.

The changes in SIRI version 2.0 include:

- a) consolidating the fixes and minor changes from SIRI in the informal working schemas;
- b) dropping the flat groups provided for VDV;

NOTE Not backwards compatible.
- c) clarifying a number of points of interpretation;
- d) a small number of functional enhancements to the ET, PT, ST, SM, and VM services as agreed by the SIRI Working Group. See Readme for further details. For example for Prediction Quality. All such enhancements are marked 'SIRI v2.0' in this document;
- e) updating and clarifying the use of terminology to relate to NeTEx and revised Transmodel usage;
- f) adding the SIRI Simple Web Services "SIRI-LITE" as additional transport method;
- g) adding a WSDL document literal version and a WSDL2 version;
- h) revising the internal modularization of SIRI packages to improve maintainability, and a number of minor corrections to types;
- i) reviewing the documentation to correct a number minor inconsistencies and errors.

Compatibility with previous versions

All changes except #2 above are intended to be fully backwards compatible, that is to say, existing documents that validate against earlier versions of the schema will also validate against the 2.0 schema without alteration (other than to schema version numbers), and version 2.0 documents that do not use new features will validate against earlier versions. Version 2.0 documents that use new features will not be backwards compatible.

1 Scope

1.1 Interfaces specified by this standard

1.1.1 Business context

Real-time information may be exchanged between a number of different organizations, or between different systems belonging to the same organization. Key interfaces include the following:

- Between public transport vehicle control centres – generally, for fleet and network management.
- Between a control centre and an information provision system – generally, to provide operational information for presentation to the public.
- Between information provision systems – generally, sharing information to ensure that publicly available information is complete and comprehensive.
- Between information provision systems – and data aggregation systems that collect and integrate data from many different sources and different types of data supplier and then distribute it onwards.
- Between information provision systems and passenger information devices such as mobile phones, web browsers, etc.

Annex B describes the business context for SIRI in more detail.

SIRI is intended for wide scale, distributed deployment by a wide variety of installations. In such circumstances it is often not practical to upgrade all the systems at the same time. SIRI therefore includes a formal versioning system that allows for the concurrent operation of different levels at the same time and a disciplined upgrade process.

In this general framework, SIRI defines a specific set of concrete functional services. The services separate the communication protocols from the message content ('functional services'). This allows the same functional content to be exchanged using different transport mechanisms, and different patterns of exchange. Figure 1 below shows this diagrammatically.

1.1.2 SIRI communications

SIRI provides a coherent set of functional services for exchanging data for different aspects of PT operation. A common data model, based on Transmodel 5.1, is used across all services.

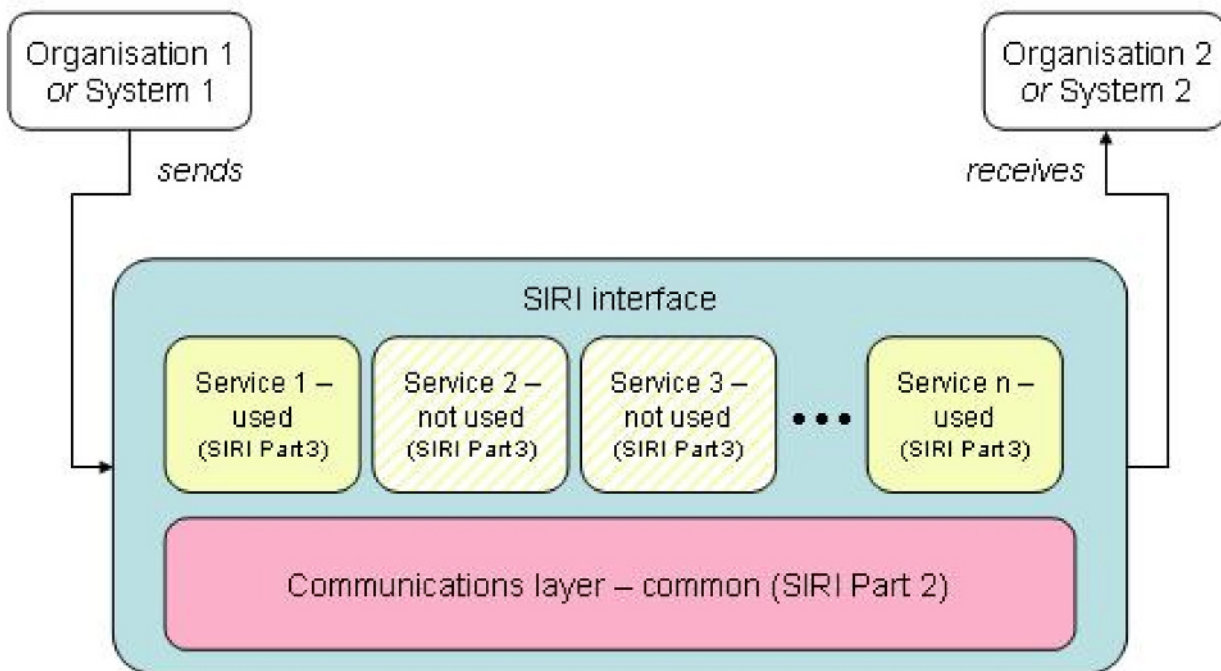

Figure 1 — Structure of SIRI: a set of optional service interface specifications using a common communications layer

A communication layer defines common procedures for the requesting and exchanging of data. Within SIRI, the same general communication protocols are used for all the different concrete functional interfaces, and specify a common infrastructure for message referencing, error handling, reset behaviour and so forth. The communications layer is defined in Part 2 of the SIRI document set.

To allow the most efficient use to be made of bandwidth and processing capacity, the SIRI communications architecture supports several different patterns of interaction. SIRI supports both request/response and publish/subscribe protocols between servers, allowing applications both to pull or to push data.

The SIRI publish/subscribe pattern of interaction follows the paradigm described in the W3C candidate standard 'Publish-Subscribe Notification for Web Services (WS-PubSub)'. SIRI uses the same separation of concerns, and a similar terminology for Publish/Subscribe concepts as is used in WS-PubSub.

For the delivery of data in response to both requests and subscriptions, SIRI supports two common patterns of message exchange as realized in existent national systems:

- one-step 'direct' delivery: allowing the simple rapid delivery of data;
- two-step 'fetched' delivery: allowing a more optimized use of limited resources.

1.1.3 SIRI functional services

SIRI provides specific protocols for the following functional services, defined in Part 3 of the SIRI document set:

- **Production Timetable (PT) Service:** to send daily information on the operational timetable and associated vehicle running information.

- **Estimated Timetable (ET) Service:** to send real-time information on timetable, including changes based on the production service and on actual running conditions.
- **Stop Timetable (ST) Service:** to provide a stop-centric view of timetabled vehicle arrivals and departures at a designated stop.
- **Stop Monitoring (SM) Service:** to send real-time arrival & departure information relating to a specific stop.
- **Vehicle Monitoring (VM) Service:** to send real-time information on the movement and predicted movement of vehicles.
- **Connection Timetable (CT) Service:** to send an operational timetable for a service feeding an interchange, in order to inform departing services of the possible need to wait for connecting passengers.
- **Connection Monitoring (CM) Service:** to send real-time information on the running of a service inbound to an interchange, in order to advise departing services of the need to wait for connecting passengers. This can also be used to send real-time information to assist passengers in planning their onward journey following a connection.
- **General Message (GM) Service:** to exchange informative messages between participants.

Two additional functional services, are provided as additional parts:

- **Facilities Management (FM) Service:** to exchange information on the current status of facilities such as lifts, escalators or ticketing machines (Part 4).
- **Situation Exchange (SX) Service:** to exchange information messages between identified participants in a standardized structured format suitable for travel information services (Part 5).

1.2 Use of the SIRI standard

As a framework standard, it is not necessary for individual systems or specifications to implement the whole of the SIRI standard. Specifically it is intended that individual national bodies may adopt consistent subsets of the standard. However, it should be possible to describe (for those elements of systems, interfaces and specifications which fall within the scope of SIRI):

- the aspects of SIRI that they have adopted;
- the aspects of SIRI that they have chosen not to adopt.

In other words, there is no global statement of which elements are mandatory and which optional (except for key fields which are clearly always mandatory).

SIRI is a modular and expandable standard, and the modules included in this version are only a subset of what might potentially be included. Specifically, the current issue of the SIRI specification excludes the following:

- interfaces with traffic management systems for traffic light priority;
- control action functions, e.g. instructions to a vehicle to change its running;
- functionality of actual systems – SIRI only specifies the interfaces between servers, not how they choose to implement it.

Since its inception SIRI has been enhanced and extended to meet additional requirements. The potential for SIRI to be expended to encompass additional services will continue to be reviewed in future.

Guidance on the implementation and use of SIRI is not part of the specification. It is a matter for individual users and national groupings to provide advice and guidance on how SIRI may be used in support of local practices.

Note also that the SIRI communications layer does not specify the communication bearer technologies to be used. SIRI has been specifically developed to be 'technology independent' in this regard, so that local implementations can select the most cost-effective services for their projects.

Of course different technologies have different characteristics, and this may have an impact on the way that SIRI is used in practice. For example, the latency (time delay imposed by the communications network) of a service such as public GPRS is much higher than that on a dedicated, broadband fixed link using DSL. Therefore, systems based on GPRS will need to use a much higher value for some or all of the hysteresis parameters.

1.3 Limitations on SIRI and possible future developments

The developers of this standard recognize that there is continual development in the business practice of the public transport industry, and that SIRI shall continue to evolve to fulfil its needs. Specifically, there is scope for additional elements to be included in two places:

- Communications (SIRI Part 2). New mechanisms of data communication are constantly becoming available, in particular for areas such as information security and data discovery. SIRI is intended to be in line with prevailing information systems industry practice and Part 2 aims to retain flexibility in use of communications technologies. SIRI 2.0 introduces additional transports in form of the Document Literal WSDL and a RESTful presentation of services.
- Applications (SIRI Part 3, Part 4, Part 5, etc). This standard is based on a specific set of interfaces, representing a subset of practical needs among participant countries. However, new models of business cooperation may arise which necessitate additional application interface specifications. The current functional services are not intended to be a complete set of interfaces and additional modules might be required in future.
- Architectural detail. This standard is based on a very high-level decomposition of public transport operations, and implements only the most common interfaces. This may not fulfil all the needs of an implementer; for example, Scandinavia and the UK both have a relatively high degree of organizational disaggregation, and as a result may need standardization on what would be 'internal' interfaces elsewhere in Europe.

CEN welcomes input from users of this Standard as to where SIRI needs extension or refinement.

2 Normative references

The following documents, in whole or in part, are normatively referenced in this document and are indispensable for its application. For dated references, only the edition cited applies. For undated references, the latest edition of the referenced document (including any amendments) applies.

EN 12896, *Road transport and traffic telematics - Public transport - Reference data model*

ISO 639-1, *Codes for the representation of names of languages - Part 1: Alpha-2 code*

ISO 8601, *Data elements and interchange formats - Information interchange - Representation of dates and times*

3 Terms and definitions

For the purposes of this document, the following terms and definitions apply.

3.1 Transport related terms

This section includes terms for both PT entities and properties of PT entities used in SIRI. For each term, it is indicated whether the term derives from Transmodel (EN 12896 version 5.0) or whether the term is specific to SIRI.

Data elements taken from Transmodel are written in capital letters in the text parts of this document (as it is in EN 12896 ex PARKING POINT) to distinguish between terms and Transmodel data elements. Data elements defined in SIRI are written with capital first letters of the nouns (ex: Subscription Identifier) .

3.1.1

bearing

heading of the vehicle in degrees expressed as a floating point number

[SOURCE: CEN/TS 13149-6]

3.1.2

block - Transmodel

work of a vehicle from the time it leaves a PARKING POINT after parking until its next return to park at a PARKING POINT

Note 1 to entry: Any subsequent departure from a PARKING POINT after parking marks the start of a new BLOCK. The period of a BLOCK has to be covered by DUTIES.

3.1.3

call activity – SIRI

activity a passenger may undertake when a VEHICLE calls at a stop; Boarding, Alighting, or Pass Through

3.1.4

call - SIRI / NeTEx

visit by a Vehicle to a specific Scheduled Stop Point as it follows the Journey Pattern of its Vehicle Journey to achieve a set of planned and estimated Passing Times

Note 1 to entry: A Vehicle may make more than one Call to the same stop in the course of a Journey: different Calls may typically be distinguished by a Visit Number count. The Call may have real time data associated with it.

Note 2 to entry: A SIRI Call may be regarded as a useful optimization of a more normalized set of structures that are articulated separately in Transmodel. Call combines the Transmodel elements of Point In Journey Pattern in with Estimated Passing Time, Observed Passing Time, & Target Passing Time, along with real time elements and other stop properties pertaining to the visit. Note that SIRI segregates all elements pertaining to arrival from those pertaining to departure, again facilitating the validation and implementation of actual systems.

3.1.5

change of journey pattern – Transmodel

CONTROL ACTION consisting in assigning a new JOURNEY PATTERN (and the ROUTE supporting it) to a DATED VEHICLE JOURNEY

3.1.6

cleardown – SIRI

act of removing a STOP VISIT from a DISPLAY once a vehicle has arrived at a stop

Note 1 to entry: For improved latency, 'Direct Cleardown' may often be done by direct wireless communication between the approaching vehicle and the stop display equipment, as well as by the regular back-end communication

between the Stop Monitoring Producer server and the Stop Monitoring Consumer entity of the client system driving the stop display.

Note 2 to entry: A separate Cleardown identifier may be associated with each STOP VISIT for this purpose, which can be used to reconcile the previous STOP VISIT with the arriving vehicle; typically this will be a short numeric code designed to be efficient for communication over a radio channel of restricted capacity.

3.1.7

connection activity – SIRI

change to the planned arrival to, or departure from, a CONNECTION link for a VEHICLE JOURNEY that is material to passengers intending to make a planned interchange

Note 1 to entry: Events may include a delayed arrival of the FEEDER, a decision to prolong the wait by the DISTRIBUTOR vehicle, a change of the distributor departure point, or cancellation of either of the feeder or distributor journeys.

3.1.8

connection protection – SIRI

coordination of inbound FEEDER and outbound DISTRIBUTOR journeys at an interchange so as to maximize the chances of passengers achieving their journeys

Note 1 to entry: Involves the exchange of information between feeder and distributor to inform dispatchers and passengers of the current situation, and the delaying of distributor vehicles so as to honour GUARANTEED CONNECTIONS.

3.1.9

connection – Transmodel / NeTEx

physical (spatial) possibility for a passenger to change from one public transport vehicle to another to continue a trip

Note 1 to entry: Different transfer times may be necessary to cover interchange over a given CONNECTION link, depending on the kind of passenger.

Note 2 to entry: In SIRI, a Feeder service may arrive at one STOP POINT in the CONNECTION link, and the Distributor may leave from the same or a different stop in the CONNECTION link.

Note 3 to entry: The interchange duration, i.e. transfer time is the time needed to go from SCHEDULED STOP POINT to SCHEDULED STOP POINT across a CONNECTION link. In SIRI, it does not include time needed to board or alight. Several different types of interchange duration may be specified.

Note 4 to entry: CONNECTION LINK has been renamed CONNECTION in NeTEx.

3.1.10

connection monitoring – SIRI

real-time monitoring of FEEDER arrivals at an interchange

3.1.11

control action – Transmodel

action resulting from a decision taken by the controller causing an amendment of the operation planned in the PRODUCTION PLAN

3.1.12

control centre – SIRI / NeTEx

CONTROL CENTRE is an ORGANIZATIONAL UNIT that manages a network or networks of vehicles and their attendant real-time systems

Note 1 to entry: In practice there is often a one-to-one corresponding between a control centre and a SIRI Service Participant. Each CONTROL CENTRE has a unique identifier, (the Control Centre Code), which provides a scope (i.e. unique namespace) for all non-global data references, such as stop identifiers, vehicle identifiers, etc. Within a Control

centre, references have to be unique. VEHICLES and JOURNEYS within the span of control of a given Control Centre are Local; VEHICLES and JOURNEYS within the span of control of an external Control Centre are Foreign.

3.1.13

coupled journey – Transmodel

complete journey operated by a coupled train, composed of two or more VEHICLE JOURNEYS remaining coupled together all along a JOURNEY PATTERN. A COUPLED JOURNEY may be viewed as a single VEHICLE JOURNEY

3.1.14

course of journey – Transmodel

part of a BLOCK, composed of consecutive VEHICLE JOURNEYS defined for the same DAY TYPE, all operated on the *same* LINE. Also sometimes termed a Run

3.1.15

data system – Transmodel

origin of operational data referring to one single responsibility

Note 1 to entry: References to a data system are useful in an interoperated computer system.

Note 2 to entry: For SIRI, this entails in particular specific systems for assigning unique identifiers to relevant entities such as SCHEDULED STOP POINTS or JOURNEYS, about which messages are to be exchanged, and which can be matched to the locally known entities identified by the respective internal operating data. The DATA SYSTEM shall be mutually agreed between Client and Server. A DATA SYSTEM has both a data model to describe the entities and their relationships, and a Namespace to describe the unambiguous set of identifier values.

3.1.16

dated vehicle journey – Transmodel

particular journey of a vehicle on a particular OPERATING DAY, including all modifications decided by the control staff

3.1.17

delayed – SIRI

categorization of a VEHICLE JOURNEY for presentation as being late and subject to significant uncertainty caused either by a Disturbance to the transport network or a problem with the VEHICLE itself

3.1.18

delivery variant – NeTEx

variant text of a NOTICE for use in a specific media or delivery channel (voice, printed material, etc.)

3.1.19

destination display – Transmodel (with clarification)

advertised destination of a specific JOURNEY PATTERN, usually displayed on a headsign or at other on-board locations

Note 1 to entry: In SIRI, different values for DESTINATION DISPLAY may be used in the dated timetable, the real-time table, or on individual calls to support stop centric and vehicle centric presentations of information to the customer. If not specified on an individual CALL element, the DESTINATION DISPLAY will be inherited from the most recent previous CALL element. If there are no values on previous calls, it will be inherited from the DATED VEHICLE JOURNEY destination displays.

3.1.20

direction – Transmodel

classification for the general orientation of ROUTES

3.1.21

display assignment – NeTEx

assignment of one SCHEDULED STOP POINT and one JOURNEY PATTERN to a PASSENGER INFORMATION FACILITY, specifying that information on this SCHEDULED STOP POINT and this JOURNEY PATTERN will be provided (e.g. displayed, printed)

Note 1 to entry: Equivalent to a SIRI MONITORING POINT.

3.1.22

distributor – SIRI / NeTEx

role of the outgoing VEHICLE from a TARGETED INTERCHANGE, which picks up passengers from a CONNECTION link who have transferred from a Feeder Service. Sometimes also called a “Fetcher”

3.1.23

distributor departure – SIRI

departure of an outgoing distributor VEHICLE JOURNEY from a CONNECTION link

3.1.24

early – SIRI / NeTEx

categorization used in data presentations to indicate that the vehicle has been classified as early against some criteria

Note 1 to entry: The status of “Early” will be derived from the real-time progress data. This term should be contrasted with SCHEDULE DEVIATION which specifies the deviation from schedule in seconds.

3.1.25

estimated passing time – Transmodel

time data, calculated from the latest available input, about when a public transport vehicle will pass a particular POINT IN JOURNEY PATTERN on a specified MONITORED VEHICLE JOURNEY

Note 1 to entry: These are mainly used to inform passengers about expected times of arrival and/or departure, but may also be used for monitoring and re-planning. See also OBSERVED (ACTUAL) PASSING TIME, TARGET (AIMED) PASSING TIME and TIMETABLED PASSING TIME.

3.1.26

event – Transmodel

EVENT may be raised in response to the disturbance and over the lifetime of the EVENT one or more CONTROLLER ACTIONS and messages may then be associated with it

Note 1 to entry: In SIRI, the EVENT is generally avoided in favour of more specific terms for entities.

3.1.27

facility – SIRI (Conflict with NeTEx)

EQUIPMENT or LOCAL Service that provides a specific convenience or service to passengers

EXAMPLE Ticket machines, elevators, mechanical stairs, toilets, porterage, left luggage, etc. A facility may be an equipment, a service, a personal device or a reserved area.

Note 1 to entry: in NeTEx, a facility is a named amenity available to the public at a SITE or on a Service. A facility has no further properties other than a name. An EQUIPMENT or LOCAL Service is used to describe the further properties provided as part of particular facility

3.1.28

facility condition – SIRI

particular mode of being of a facility (EQUIPMENT); describing its state and availability

3.1.29

feeder – SIRI (Informal Transmodel term)

role of the incoming VEHICLE to and VEHICLE JOURNEY at a TARGETED INTERCHANGE, which feeds passengers to an arrival SCHEDULED STOP POINT having a CONNECTION link to a departure SCHEDULED STOP POINT from where they will board a Distributor Service

Note 1 to entry: A VEHICLE may perform both feeder and distributor roles at the same time, that is, both set down passengers to transfer to other services, and board passengers from other services.

3.1.30

feeder arrival – SIRI

arrival of an incoming feeder VEHICLE JOURNEY to a CONNECTION link

3.1.31

foreign vehicle – SIRI (Informal Transmodel Term)

given ORGANIZATIONAL UNIT, i.e. SIRI Control Centre system, manages its own set of Local VEHICLES and VEHICLE JOURNEYS, for which it is responsible for provisioning and updating the data

Note 1 to entry: It may also need to manage data for Foreign VEHICLES and VEHICLE JOURNEYS, whose data is originated by a different Control Centre. A Foreign Vehicle is thus a local VEHICLE from one Control Centre that is roaming into the area managed by another Control Centre.

3.1.32

group of lines – NeTEx

grouping of LINES which will be commonly referenced for a specific purpose

3.1.33

headway interval – SIRI / NeTEx

for frequency based services, the interval between vehicles

Note 1 to entry: It may be TIMETABLED, AIMED, ESTIMATED or ACTUAL.

3.1.34

headway SERVICE – SIRI

frequent service whose time of departure is normally shown to the public as 'every n minutes' rather than a fixed time

3.1.35

incident –Transmodel

unforeseen EVENT influencing the operation of the network

Note 1 to entry: In SIRI, progression of an incident is represented by a SITUATION.

3.1.36

in congestion – SIRI

status of a VEHICLE stuck in a traffic jam causing its journey to be delayed and subject to non-deterministic factors; any predictions are likely to be inaccurate

3.1.37

in panic – SIRI

status of a VEHICLE with an active panic alarm indicating a security or other incident that is likely to delay the journey according to non-deterministic factors; any predictions are likely to be inaccurate

3.1.38

interchange rule – NeTEx

conditions for considering JOURNEYS to meet or not to meet, specified indirectly: by a particular MODE, DIRECTION or LINE

Note 1 to entry: Such conditions may alternatively be specified directly, indicating the corresponding services. In this case, they are either a SERVICE JOURNEY PATTERN INTERCHANGE or a SERVICE JOURNEY INTERCHANGE.

3.1.39

journey cancellation – Transmodel

CONTROL ACTION consisting in deleting a DATED VEHICLE JOURNEY from the latest valid plan

3.1.40

journey creation – Transmodel

CONTROL ACTION consisting in adding a completely new DATED VEHICLE JOURNEY to the latest valid plan

3.1.41

journey meeting – Transmodel

time constraint for one or several SERVICE JOURNEYS fixing interchanges between them and/or an external event (e.g. arrival or departure of a feeder line, opening time of the theatre, etc.)

3.1.42

journey part – Transmodel

part of a VEHICLE JOURNEY created according to a specific functional purpose, for instance in situations when vehicle coupling or separating occurs

3.1.43

journey pattern – Transmodel

ordered list of SCHEDULED STOP POINTs and TIMING POINTs on a single ROUTE, describing the pattern of working for public transport vehicles

Note 1 to entry: A JOURNEY PATTERN may pass through the same POINT more than once. The first point of a JOURNEY PATTERN is the origin. The last point is the destination. Every VEHICLE JOURNEY has a JOURNEY PATTERN associated with it.

Note 2 to entry: In SIRI, JOURNEY PATTERNS are not explicitly exposed in the interface: the LINE and Route DIRECTION elements that appear on VEHICLE JOURNEYS are assumed to be derived from the associated journey pattern.

3.1.44

late – SIRI

categorization in presentations indicating that the vehicle has been classified as LATE i.e., that a VEHICLE is running behind schedule in excess of some specified criteria

Note 1 to entry: The status of LATE will be derived from the real-time progress data.

3.1.45

line – Transmodel

group of ROUTEs which is generally known to the public by a similar name or number

3.1.46

line number – Transmodel

integer or a short alphanumeric sequence used to identify the LINE to the Public, for example: 11, 23, X3, 5A, etc.

3.1.47

location – Transmodel

position of a POINT with a reference to a given LOCATING SYSTEM (e. g. coordinates)

3.1.48

local vehicle – SIRI

given ORGANIZATIONAL UNIT, using a SIRI CONTROL CENTRE system, manages its own set of local VEHICLES and VEHICLE JOURNEYS, for which it is responsible for provisioning and updating the data

3.1.49

logical display – NeTEx

set of data that can be assembled for assignment to a physical PASSENGER INFORMATION EQUIPMENT or to a logical channel such as web or media; it is independent of any physical embodiment

Note 1 to entry: A LOGICAL DISPLAY may have a set of DISPLAY ASSIGNMENTS each of which associates a JOURNEY PATTERN whose journeys are to be shown at the LOGICAL DISPLAY. It may also be associated with a SCHEDULED STOP POINT.

Note 2 to entry: LOGICAL DISPLAY corresponds to a SIRI STOP MONITORING point.

3.1.50

monitored call – SIRI

CALL that is part of a MONITORED VEHICLE JOURNEY and so subject to real-time monitoring

3.1.51

monitored connection – SIRI

CONNECTION that is subject to real-time monitoring

3.1.52

monitored vehicle journey – Transmodel

journey that is monitored as being operated by a LOGICAL VEHICLE

Note 1 to entry: According to the monitoring system capabilities, a MONITORED VEHICLE JOURNEY may be related to a DATED VEHICLE JOURNEY, or only to a JOURNEY PATTERN.

3.1.53

observed passing time – Transmodel

actual passing of a public transport vehicle at a pre-defined POINT during a MONITORED VEHICLE JOURNEY

Note 1 to entry: See also TARGET PASSING TIME and ESTIMATE PASSING TIME.

3.1.54

notice – NeTEx

text for informational purposes on exceptions in a LINE, a JOURNEY PATTERN, etc.

Note 1 to entry: The information may be usable for passenger or driver information.

3.1.55

passing time – Transmodel

concept of PASSING TIME may be viewed as a simple passage (e.g. of a bus at a stop point) or as a longer stay (e.g. in maritime ports of call)

Note 1 to entry: The attributes describing the waiting time in the subtypes of PASSING TIME, in particular, will be used to describe such a call. The attribute 'alight and reboard' will express the possibility for the passenger to alight for a while, during the PASSING TIME of a VEHICLE JOURNEY at a particular SCHEDULED STOP POINT.

Note 2 to entry: The PASSING TIMES that are computed on a specific OPERATING DAY are called DATED PASSING TIME. This entity has several subtypes:

— TARGET PASSING TIME, the latest official plan for a DATED VEHICLE JOURNEY, on a POINT IN JOURNEY PATTERN;

— ESTIMATED PASSING TIME, a forecast for a MONITORED VEHICLE JOURNEY, on a POINT IN JOURNEY PATTERN;

— OBSERVED PASSING TIME, recorded for a MONITORED VEHICLE JOURNEY, on a particular POINT

Note 3 to entry: In SIRI Passing times are subsumed into a CALL entity. See Discussion later.

3.1.56

occupancy – SIRI (Informal Transmodel term)

number of passengers on a vehicle

3.1.57

on time – SIRI

categorization in presentations indicating that the VEHICLE has been classified as neither LATE nor EARLY i.e., that a VEHICLE is running according to schedule within some specified criteria

Note 1 to entry: The status of LATE will be derived from the real-time progress data.

3.1.58

operating day – Transmodel

day of public transport operation in a specific calendar; an OPERATING DAY may last more than 24 h

3.1.59

passenger trip – SIRI (Informal Transmodel term)

trip made by a traveller when moving from one PLACE to another using scheduled transport; a PASSENGER TRIP may consist of one or more RIDES using different vehicles

3.1.60

passenger information facility – Transmodel / NeTEx

public transport information facility, as for instance terminals (on street, at information desks, telematic,...) or printed material (leaflets displayed at stops, booklets)

Note 1 to entry: SIRI does not model or represent PASSENGER INFORMATION FACILITIES; rather it describes services that may be used to supply PASSENGER INFORMATION FACILITIES. A LOGICAL DISPLAY (Monitoring Point) is used to assign services.

3.1.61

place – Transmodel

geographic place of any type which may be specified as the origin or destination of a trip; a PLACE may be of dimension 0 (a POINT), 1 (a road section) or 2 (a ZONE)

3.1.62

point – Transmodel

0-dimensional node of the network used for the spatial description of the network; POINTs may be located by a LOCATION in a given LOCATING SYSTEM

3.1.63

point in journey pattern – Transmodel

STOP POINT or TIMING POINT in a JOURNEY PATTERN with its order in that JOURNEY PATTERN

3.1.64

prediction inaccurate – SIRI

basic data quality measure used to indicate when the Predicted Times are known or thought to be imprecise

Note 1 to entry: In some cases, the cause of the inaccuracy may be indicated by a more specific reason, for example IN CONGESTION.

3.1.65

prediction quality level – SIRI

description of the level of reliability of a predicted time from a producer AVMS system

3.1.66

product category – SIRI

a sub-classification of a transport mode, for example as 'express'

3.1.67

production plan – Transmodel

reference version of production activities (service journeys, dead runs, duties)

Note 1 to entry: CONTROL ACTIONS are described with reference to the PRODUCTION PLAN they amend.

3.1.68

production timetable – SIRI

revised version of the TIMETABLE for a Service containing updates to the original published timetable

Note 1 to entry: The original TIMETABLED TIMES are referred to as TARGET TIMES.

3.1.69

pt trip – Transmodel

part of a trip starting from the first boarding of a public transport vehicle to the last alighting from a public transport vehicle

Note 1 to entry: A PT TRIP consists of one or more RIDEs and the movements (usually walks) necessary to cover the corresponding CONNECTION links.

3.1.70

quay – IFOPT / NeTEx

place such as platform, stand, or quayside where passengers have access to PT vehicles, taxi, cars or other means of transportation

Note 1 to entry: A QUAY may serve one or more VEHICLE STOPPING PLACES and be associated with one or more SCHEDULED STOP POINTS.

Note 2 to entry: A QUAY may contain other sub QUAYs. A child QUAY shall be physically contained within its parent QUAY.

Note 3 to entry: A QUAY represents the physical entity and is distinct from the SCHEDULED STOP POINT. Many implementations use a single entity for both concepts.

3.1.71

ride – Transmodel

part of a TRIP corresponding to the theoretical movement of a user (passenger, driver) on one and only one public transport vehicle, from one SCHEDULED STOP POINT to another, on one JOURNEY PATTERN

Note 1 to entry: A traveller will take one or more RIDES during a TRIP. Each RIDE will be taken using a particular VEHICLE JOURNEY although the RIDE may be shorter than the VEHICLE JOURNEY.

3.1.72

roaming – SIRI

movement of a VEHICLE through the area managed by a different CONTROL CENTRE; within its home CONTROL CENTRE the vehicle is Local, in other CONTROL CENTRES it is Foreign

3.1.73

route – Transmodel

ordered list of located POINTs defining one single path through the road (or rail) network; a ROUTE may pass through the same POINT more than once

Note 1 to entry: Each JOURNEY PATTERN may be associated with a particular ROUTE.

3.1.74

scheduled stop point – Transmodel

POINT where passengers can board or alight from vehicles

Note 1 to entry: In SIRI 1.0 this was called STOP POINT. It has been renamed to SCHEDULED STOP POINT to distinguish it from STOP PLACE.

3.1.75

schedule deviation – SIRI

the estimated deviation from the schedule for a VEHICLE JOURNEY, specified in seconds

Note 1 to entry: In SIRI, positive values are associated with VEHICLES that are behind their schedule, negative values with ones that are ahead.

3.1.76

service journey – Transmodel

passenger carrying VEHICLE JOURNEY for one specified DAY TYPE; the pattern of working is in principle defined by a SERVICE JOURNEY PATTERN

3.1.77

service journey interchange – Transmodel

scheduled possibility for transfer of passengers between two SERVICE JOURNEYS at the same or different STOP POINTs

Note 1 to entry: In SIRI, there are mechanisms for managing the real-time SERVICE JOURNEY INTERCHANGE between Feeder VEHICLE JOURNEYS and Distributor VEHICLE JOURNEYS. Also known as “Connection Protection”.

Note 2 to entry: There are four different degrees of interchange management:

- PLANNED – an interchange is intended in the normal static timetable;
- ADVERTISED – an interchange is intended and is publicized as being possible;
- CONTROLLED – the interchange is actively monitored to inform travellers whether the interchange can be made;
- GUARANTEED – the DISTRIBUTOR Service will be delayed to ensure the interchange can take place.

Note 3 to entry: The SERVICE JOURNEY INTERCHANGE allows as well the storing of a quality parameter for ensuring interchanges, providing the maximum time a vehicle may wait for connecting vehicles, beyond the planned departure time.

3.1.78

service pattern – Transmodel

subset of a JOURNEY PATTERN made up only of STOP POINTs IN JOURNEY PATTERN

3.1.79

short working – SIRI

strategy to bring a vehicle back onto schedule by curtailing the end of one VEHICLE JOURNEY and the start of another; SHORT WORKING is a type of CHANGE IN JOURNEY PATTERN

3.1.80

situation – Trident / SIRI

set of traffic/travel circumstances linked by a causal relationship which apply to a common set of locations; a SITUATION can be composed of SITUATION elements

3.1.81

stop area – Transmodel

group of SCHEDULED STOP POINTs close to each other

3.1.82

stop monitoring – SIRI

monitoring of the real time status and expected activities of VEHICLE arrivals and departures at a STOP MONITORING POINT

Note 1 to entry: The SIRI Stop Monitoring Service provides information of the real time status and expected activities for one or more MONITORING POINTs, corresponding typically to STOP POINTs.

3.1.83

stop monitoring point – SIRI

point at which real-time status is reported on a display or other visualization; normally corresponds to a SCHEDULED STOP POINT

Note 1 to entry: This corresponds to the NeTex LOGICAL DISPLAY.

3.1.84

stop assignment – NeTex

allocation of a SCHEDULED STOP POINT (i.e. a STOP POINT of a SERVICE PATTERN or JOURNEY PATTERN) of the timetable to a specific STOP PLACE, for either a Passenger JOURNEY or VEHICLE Service

Note 1 to entry: Some systems use a single entity for a SCHEDULED STOP POINT and for a physical QUAY of a STOP PLACE and use a single identifier for both concepts. In this case it can be considered that there is an implicit assignment.

3.1.85

stop order – Transmodel

sequence of a SCHEDULED STOP POINT within a JOURNEY PATTERN distinguishing repeated visits to a stop by a vehicle within the same journey pattern

Note 1 to entry: A monotonically increasing number that is unique within a given JOURNEY PATTERN, but is not necessarily strictly sequential. The number provides both a unique identifier and a relative ordering.

3.1.86

stop place – IFOPT / NeTex

place comprising one or more locations where vehicles may stop and where passengers may board or leave vehicles or prepare their trip

Note 1 to entry: A STOP PLACE will usually have one or more well-known names.

3.1.87

stop visit – SIRI

discrete visit by a VEHICLE making a call at a STOP POINT in the course of a DATED VEHICLE JOURNEY

Note 1 to entry: The visit may include an arrival, departure or both, for each of which it may have separate Targeted (aimed), Estimated and Observed (Actual) times.

3.1.88

stop visit count – SIRI

means of distinguishing repeated visits to a stop by a VEHICLE within the same JOURNEY PATTERN

Note 1 to entry: A monotonically increasing number that is unique within a given STOP POINT for a given JOURNEY PATTERN.

Note 2 to entry: For example, the count for the first visit to the stop would be “1”, the second “2”, etc. When combined with the STOP POINT identifier the STOP VISIT COUNT can be used to uniquely identify the position of the vehicle along a JOURNEY PATTERN.

3.1.89

target passing time – Transmodel

time data about when a public transport vehicle should pass a particular POINT IN JOURNEY PATTERN on a particular DATED VEHICLE JOURNEY, in order to match the latest valid plan

Note 1 to entry: See also OBSERVED PASSING TIME and ESTIMATED PASSING TIME.

Note 2 to entry: In Transmodel, TARGET is synonymous with AIMED.

3.1.90

timing point – Transmodel

POINT against which the timing information necessary to build schedules may be recorded

Note 1 to entry: In SIRI, may be, but is not necessarily, a SCHEDULED STOP POINT. In many systems, Target Times for stops that are not timing points are interpolated simplistically from the timing points by either the scheduling system, or the AVMS system, and may represent a lower level of accuracy of prediction.

3.1.91

timetabled – Transmodel

TIMETABLED arrival or departure time for a VEHICLE JOURNEY at a SCHEDULED STOP POINT is the planned time for this event, as distinct from the ESTIMATED or OBSERVED time

Note 1 to entry: In Transmodel, TIMETABLED is synonymous with ‘Scheduled’.

3.1.92

train – Transmodel

vehicle composed of TRAIN ELEMENTs in a certain order, i.e. of wagons assembled together and propelled by a locomotive or one of the wagons

3.1.93

train block – Transmodel

composite train formed of several TRAIN BLOCK PARTs coupled together during a certain period; any coupling or separation action marks the start of a new TRAIN BLOCK

3.1.94

train block part – Transmodel

component of a vehicle TRAIN BLOCK

3.1.95

train component – Transmodel

specification of the order of TRAIN ELEMENTs in a TRAIN

3.1.96

train element – Transmodel

elementary component of a TRAIN (e.g. wagon or locomotive)

3.1.97

train number – NeTEx

specification of codes assigned to particular VEHICLE JOURNEYS when operated by TRAINS or COMPOUND TRAINS according to a functional purpose (passenger information, operation follow-up, etc.)

3.1.98

vehicle journey – Transmodel

planned movement of a public transport vehicle on a DAY TYPE from the start point to the end point of a JOURNEY PATTERN on a specified ROUTE

Note 1 to entry: In SIRI, the VEHICLE makes a CALL at each stop, for timetabled stops at a specific PASSING TIME. There may be a separate arrival time and departure time. A DATED VEHICLE JOURNEY is an instance of a VEHICLE JOURNEY made on a specific calendar day.

3.1.99

vehicle monitoring – Transmodel

activity consisting in the assignment, at a certain time, of operational data to a monitored LOGICAL VEHICLE (e.g. that the vehicle is operating a certain MONITORED VEHICLE JOURNEY, or has passed at a certain OBSERVED PASSING TIME at a POINT)

Note 1 to entry: In SIRI, the information reported by the SIRI Vehicle Monitoring Service may include both the vehicle's location, i.e. geospatial position, and other operational data such as the number of passengers, and whether it is in congestion.

3.1.100

Version – Transmodel

group of operational data instances which share the same VALIDITY CONDITIONS

Note 1 to entry: A version belongs to a unique VERSION FRAME and is characterized by a unique TYPE OF VERSION. E.g. NETWORK VERSION for Line 12 starting from 2000-01-01.

Note 2 to entry: In the SIRI Interface, versions are also used for software release levels.

3.1.101

version frame – Transmodel

set of VERSIONS referring to the same DATA SYSTEM and belonging to the same TYPE OF FRAME

Note 1 to entry: A FRAME may be restricted by VALIDITY CONDITIONS.

Note 2 to entry: In SIRI, used to group VEHICLE JOURNEYS into a timetable.

3.1.102

visit number – SIRI

means of distinguishing repeated visits to a stop by a VEHICLE within the same JOURNEY PATTERN

Note 1 to entry: A monotonically increasing number that is unique *within a given SCHEDULED STOP POINT* for a given journey pattern, as distinct from the Transmodel ORDER; a monotonically increasing number that is unique on each call within a given JOURNEY PATTERN (i.e. that provides an overall serial ordering and unique identification of the stop within the whole JOURNEY PATTERN).

Note 2 to entry: Same concept as stop visit count (3.1.88).

3.1.103

zone – Transmodel

two-dimensional PLACE within the service area of a public transport OPERATOR (administrative zone, TARIFF ZONE, ACCESS ZONE, etc.)

3.2 Communications and software concepts

For each term, it is indicated whether the term derives from WS-PubSub, general software usage, or whether the term is specific to SIRI.

3.2.1

access control – SIRI

application mechanism used to check Requests against a predefined set of Permissions to ensure that a Requestor or Subscriber is allowed to use the service according to an Authorization policy

Note 1 to entry: The policy may set what Capabilities the Subscriber may access, what Topic content they may retrieve, and how much computational resource they may consume.

3.2.2

access permission – SIRI

application mechanism used to specify whether a participant may use Service Capabilities, or access, specific Topic content of a Service

3.2.3

account – SIRI

registered user of a SIRI service used to track use of the service by a participant system or a group of End Users

Note 1 to entry: Accounts do not normally correspond to individual end users, but rather to an application shared by a number of users.

3.2.4

authentication key – SIRI

key value issued by the owner of a Producer for use by Consumers associated with an Account

Note 1 to entry: The key is used to authenticate their use of the service.

3.2.5

built-in constraint – General Software Term

XML allows a number of different rules as to the correct form of XML documents to be expressed in the schema using XML's Built-in language features

Note 1 to entry: For example; whether elements are optional; the multiplicity of elements; regular expression as to values and uniqueness; and keyref constraints.

3.2.6

capability – SIRI

coherent named set of features that a SIRI Functional Service may implement to provide particular application functionality

Note 1 to entry: Some capabilities are common to all services; others are specific to individual functional services. Each SIRI functional service has a number of required capabilities, a number of capabilities for which alternatives are allowed, and a number of optional capabilities. A Capability Matrix is used both to specify the named Capabilities for each SIRI functional service, and for the capabilities common to all SIRI functional services.

3.2.7

client – General Software Term

entity that makes requests to a Server and receives responses in reply

Note 1 to entry: In this usage, client and server are roles, not specific computers: in a server-to-server environment, both 'server' computers are peers and may act as client or server depending on the specific protocols they use.

3.2.8

compound request – SIRI

request that contains more than one request for a concrete SIRI Functional Service within it: each concrete request specifies a different topic

Note 1 to entry: Similarly a compound subscription contains more than one SIRI Functional Service subscription request.

3.2.9

configuration – General Software Term

process of deploying a computer system or systems in an environment so that they will function, including setting appropriate values for all parameterized properties such as Endpoint Addresses, Capabilities, and PERMISSIONS and provisioning with data

3.2.10

consumer – WS-PubSub

entity that receives Notification messages from a Producer as a result of a previous Subscription made to a Service

Note 1 to entry: In SIRI, in order to manage recovery, a Consumer shall know the Subscriber which asked for its subscriptions.

3.2.11

data horizon – SIRI

span of time within which data of a given type is available

Note 1 to entry: For stable long term data, this may be the validity period of the timetable or stop data. For more volatile short term data such as daily operational changes, it may be a shorter operation period such as the day or week. For real-time data this will be the retention period in the system of very volatile data, such as short term movement and prediction data, for example an hour, or as soon as the data is obsolete. Systems that keep historic logs of data value may offer a longer data horizon for some types of volatile data.

3.2.12

data ready notification – SIRI

first message of the Fetched Delivery sequence: it informs the Consumer that the Notification Producer Service has updated data that is now ready to fetch using a Data Supply message

3.2.13

data validity – SIRI

period of time for which the information can be used, after which it becomes stale

3.2.14

delivery – SIRI

message or message sequence sent from the Producer to the Consumer to return payload content, either in immediate response to a Request, or sent asynchronously when a Notification Producer determines that the conditions of a Subscription are satisfied

3.2.15

direct delivery – SIRI

one-step Delivery pattern in which the notification and payload is sent as a single message from the Producer to the Consumer

3.2.16

endpoint address – WS-PubSub

address is part of Endpoint Reference, specified as (the URI to send a message to) and Endpoint Reference properties, that identify stateful resources

3.2.17

endpoint reference – WS-PubSub

web service endpoint is a referenceable entity, or processor resource to which Web Service messages can be targeted

Note 1 to entry: Endpoint References convey the information needed to identify and reference a Web service. Endpoint References are used to provide addresses for individual messages sent to and from Web Services, both synchronously and asynchronously. An endpoint reference includes an Address (the URI to which to send a message) and also Endpoint Reference Properties, that identify stateful resources, such as Subscriptions. They may also indicate a port (endpoint) and processing policies. WS-PubSub and the other web service standards require the separation of the endpoint references from their bindings to a given transport protocol, such as SOAP.

Note 2 to entry: In SIRI, each Participant is an endpoint for each of its roles in message exchange, i.e. Subscriber, Producer and Consumer. A Subscription Reference is an endpoint property and is typically made up of two parts: (i) a Participant Reference, which may be specified in the configuration to indicate the CONTROL CENTRE, and is not necessarily repeated explicitly on individual messages, and (ii) the Subscription Identifier, which is a serial number for an individual subscription that is unique within the SIRI Functional Service and Participant Reference.

3.2.18

end user – General Software term

member of the public using a mobile device or browser application that may call a SIRI functional service directly

3.2.19

error condition – SIRI

description of a recognized mode of failure, reified in SIRI as a named error

Note 1 to entry: Requests may be refused because an Error Condition is detected. Different Error conditions are each represented in SIRI as separate elements each with an error code and a recommended error handling procedure.

3.2.20

fetches delivery – SIRI

two-step Delivery in which first a Data Ready message is sent from the Producer service to the Consumer to notify the Consumer that data is ready, and then secondly the Consumer fetches the data by sending a Data Supply request to the Producer Service, which then finally sends a Data Supply Response message with the actual payload

3.2.21

filter – WS-PubSub

set of constraints on the nature and volume of data to be returned in the Delivery

Note 1 to entry: A Filter is specified on a Request or a Subscription message. Filters may include both a Topic Expression of content related terms, for example the STOP POINT, JOURNEY or Temporal span, and also a Subscription Policy, containing terms regulating the processing of the subscription, for example the volume, indicating how many entries should be returned.

3.2.22

heartbeat – SIRI

message sent at regular intervals by a Service to a Consumer to indicate it is functioning correctly

Note 1 to entry: The heartbeat frequency, that is, how often a heartbeat message should be sent, is specified as part of the subscription policy. A Heartbeat message is an optional feature of SIRI; if a heartbeat is not provided, it is the responsibility of the Subscriber to determine whether the Service has failed by periodically polling the server using the Check Status message.

3.2.23

initial termination time– WS-PubSub

service requestor's suggestion for the initial termination time of the Subscription being created, also known informally as 'Lease Wanted'

Note 1 to entry: This time is an absolute UTC time, timed according to the time source used by the Notification Producer.

3.2.24

incremental update – SIRI

delivery containing only that information which has changed since the last update

3.2.25

interface version – General Software Term

release level assigned to a coherent set of software artefacts, such as an interface

Note 1 to entry: In SIRI there are two version levels – the overall version level for the general services, and the version level for each individual SIRI functional service. The latter functional service level may be used as a single version identifier.

3.2.26

intrinsic constraint – SIRI

XML allows a number of different rules as to the correct form of XML documents to be expressed in the schema using XML's built-in language built-in features

Note 1 to entry: For example; whether elements are optional; the multiplicity of elements; any regular expressions constraining values; and uniqueness and keyref constraints. Apart from these constraints, there are some additional business rules on the structure and use of the SIRI XML model, which cannot readily be expressed using XML, but which can be clearly defined.

Note 2 to entry: These '*intrinsic*' constraints for schema cross-validation are described in the SIRI document and should be observed by implementers. For example, in a Stop Monitoring Service delivery MONITORED CALL at a stop, at least one form of time should be provided, but whether this is a target, estimated, or observed time, or even a headway frequency will depend on the service and whether the journey is monitored.

3.2.27

informative channel – SIRI

categorization of the informative messages that is used to filter messages from the message service. Informative messages have an identifier and version

3.2.28

informative message – SIRI

informational message that is exchanged between Participants using a General Message service. Informative messages have an identifier and version so they can be updated and revoked

Note 1 to entry: Their content may be in plain text, or structured according to an agreed format. Informative messages may be segregated into separate information channels according to an agreed categorization, for example, Warning, Advice, etc.

3.2.29

item – SIRI

transient data container element included in a SIRI functional service response that has a timestamp

Note 1 to entry: It may optionally have an Item Identifier which can be used to reference it subsequently, for example to associate a cancellation of an earlier item.

3.2.30

lease – WS-PubSub

allowed duration of a Subscription. In SIRI, leases are specified by an Initial Termination Time and cannot be negotiated or renewed

3.2.31

life sign – SIRI

message sent by a Consumer Client to a Producer Server to indicate that it is still interested in receiving Subscriptions

Note 1 to entry: Life-sign messages allow the Producer to detect failed clients and terminate their subscriptions, therefore making a more efficient use of its resources. SIRI does not currently provide automatic Life Sign messages

3.2.32

message reference – WS-PubSub

identifier issued to identify an individual request within a conversation, and subsequently used to refer to the request in further exchanges within a stateful resource pattern, such as Publish/Subscribe, or Fetched Delivery

3.2.33

metadata – General Software Term

any form of data about data, in particular the structure of data, for example, the name and schema of the DATA SYSTEM used to describe STOP POINTS, or the SIRI XML schemas themselves

Note 1 to entry: Also used to describe the data to categorize an xml schema or instance document for automated indexing by search engines.

3.2.34

multipart despatch – SIRI

delivery of large packet of data by breaking it down into two or more Delivery messages, chained together by a 'MoreData' flag

3.2.35

namespace – General Software Term

well-defined named scope within which a set of unambiguous, i.e. unique identifiers for a given entity type or types may be distinguished

Note 1 to entry: Separate names spaces are allowed in SIRI for various types of reference data, for example, (i) message identifiers, (ii) subscription identifiers (iii) identifiers of reference data such as stop points, product categories, etc. In SIRI the Participant Reference is used as a general purpose namespace associated with a particular Service Participant. Namespace is also used as a technical term within XML in a related sense, to identify the scope within which XML element, and attribute names are unique.

3.2.36

notification – WS-PubSub

act of transmitting a Notification Message to a Notification Consumer

Note 1 to entry: Notifications are sent from the Publisher to the Producer and then from the Producer to the Consumer.

Note 2 to entry: The direct unmediated forwarding of notifications from the Publisher by the Producer without filtering or transformation is termed '*unbrokered*' notification. SIRI requires the mediation of messages by the Producer.

3.2.37

notification consumer – WS-PubSub

client that receives Notification messages from a Notification Producer

Note 1 to entry: The role may be performed by the same or a different entity as that of the Subscriber who created the Subscription which requested the sending of the Notification messages in the first place.

3.2.38

notification producer – WS-PubSub

service that implements the distribution of Notification messages to satisfy Subscriptions; the Notification messages themselves are generated by a Publisher (and may be routed to the Notification Producer via a Notification Broker)

Note 1 to entry: A Notification Producer maintains a list of Subscription resources and uses the Topic Filters of the individual Subscriptions to match the Notification messages with the Subscribers' interests. If it identifies a match, it issues a notification to the Notification Consumer associated with the Subscription.

3.2.39

notification broker – WS-PubSub

separate intermediary entity that may be used to distribute the Notification messages produced by a Publisher entity to one or more Notification Producer services

Note 1 to entry: This allows the decoupling of Publisher and Producer roles if desired. A Notification Broker may also provide specific services such as Access Control.

3.2.40

participant – SIRI

system that participates in the exchange of messages using the SIRI protocols

Note 1 to entry: A Participant has a reference, used to identify the participant in message exchanges, and also used to provide a general purpose namespace to scope arbitrary identifiers of model elements such as line and vehicle identifiers.

Note 2 to entry: In SIRI Consumers and Notification Producers (i.e. CONTROL CENTRES) are Participants.

3.2.41

participant reference – SIRI

unique identifier of a CONTROL CENTRE or other type of service Participant

Note 1 to entry: The reference is bilaterally agreed between participating systems, and will typically be unique for a region of a country within which systems need to communicate. The Participant Reference is used to scope other data identifiers within each bilateral data reference agreement.

3.2.42

payload – SIRI

content data part of a Delivery message, as opposed to the elements used to manage the message exchange such as the Endpoint Reference elements

3.2.43

producer – WS-PubSub

entity that sends Notification messages to a Consumer as a result of a previous Subscription made to it for a Functional Service; events that give rise to Notification messages are sent to the Producer by a Publisher entity

3.2.44

provisioning – SIRI

populating of a system with a complete set of stable data necessary for its operation, both reference data and content; for example, the stop identifiers and the timetable data for an AVMS system

Note 1 to entry: Provisioning is distinct from Configuration – the setting up of the systems' operational parameters and other variable features – in that it may be routinely repeated from time to time when a new data set is prepared.

3.2.45

publish-subscribe – WS-PubSub

pattern of interaction between a Client (as Subscriber and Consumer) and Server (as Notification Producer) involving the sending of an initial Subscription and the subsequent asynchronous receipt of one or more Notification messages that contain a payload of information

Note 1 to entry: The Subscription has a Lease, which defines its duration.

3.2.46

publisher registration – WS-PubSub

Publisher Registration represents the relationship between a Publisher and a Notification Broker, an optional WS-PubSub intermediary that can be introduced to delegate the distribution of Notification messages to one or more distinct entities that act as Notification Producers

3.2.47

publisher – WS-PubSub

entity that processes events in the data feeds and sends Notification messages to a Producer for brokering and distribution to Consumers

Note 1 to entry: The Producer may carry out additional mediation such as filtering or data transformation. The use of a Notification Producer is transparent in SIRI.

3.2.48

request – General Software Term

any type of message sent from a Client to a Server to ask it to perform an action

Note 1 to entry: A Request usually has a corresponding Response, and also various Error Conditions for when the Request fails.

3.2.49

requestor – General Software Term

entity that makes a Request to a Service to ask it to perform an action or send a reply

3.2.50

schema validation – XML

process of parsing an XML document against its schema

Note 1 to entry: To be validated successfully, an XML document shall be both *well-formed*: that is, comprise a set of tags that are syntactically correct XML so that it can be parsed, and *valid*: that is, conform to any constraints expressed in its schema as to data type and integrity of reference.

3.2.51

sensitivity threshold – SIRI

term in a Subscription Policy specifying the degree of change that is permitted in the values of certain quantitative Topic data elements or other Subscription Policy values before a further update Delivery should be provided by the Server to its Subscribers

Note 1 to entry: Also known as 'hysteresis'.

3.2.52

server – General Software Term

computer running a Service that responds to Requests from a Client

3.2.53

service – WS-PubSub

process running on a server computer that responds to requests of a particular type. Some types of service may initiate requests in their own right

Note 1 to entry: SIRI is made up of a number of different types of SIRI functional Service.

3.2.54

service layer – General Software Term

separation of implementation concerns as a functional layer in the software

Note 1 to entry: Each layer encapsulates specific functions. A Service layer may only communicate with the layers above and below it. Two Service Layers are provided in SIRI; the Communications Service Layer and the Technical Service Layer. The Communications Service Layer establishes and maintains the integrity of the connection (and hides the use of a separate Transport Layer). The Technical Services Layer operates on the Communications Layer and accommodates the individual Service functions.

3.2.55

service participant – SIRI

SIRI Service Participant is a participating system that exchanges SIRI messages with another Service Participant

Note 1 to entry: Each Service Participant has a unique identifier, (the Participant Code), which provides a scope (i.e. unique namespace) for all non-global data references, such as stop identifiers, vehicle identifiers, and also for message identifiers of requests and subscriptions. Service Participants will either be SIRI Functional Service systems providing information, or accredited client systems that send request and subscriptions to the services to obtain information.

3.2.56

siri functional Service – SIRI

specific concrete Service that provides a function, such as Stop or Connection Monitoring

Note 1 to entry: It comprises a set of named messages making up a SIRI interface that shall be used according to both the general SIRI communication rules and the specific semantics of the particular Service.

3.2.57

situation – WS-PubSub

some occurrence within a service or its environment of interest to third parties

Note 1 to entry: A SITUATION can be a change of state in the service itself, or an event in the context of the systems it monitors. A Publisher that detects a Situation will create a Notification Message.

3.2.58

subscriber – WS-PubSub

entity that acts as a Service Requestor, sending a Subscription Request on behalf of a Consumer to a Notification Producer

Note 1 to entry: The Consumer entity will usually be the same entity as the Subscriber, but may also be a separate entity.

3.2.59

subscription – WS-PubSub

resource created to represent the relationship between a Notification Consumer, a Notification Producer, Topic and other filters and policies

Note 1 to entry: A Subscription is created when a Subscriber sends a Subscribe message to a Notification Producer, which acts as the factory for new subscriptions. A Subscription may be subsequently altered through a Subscription Manager.

3.2.60

subscriber channel – SIRI

SIRI Notification Producer mediates the flow of notifications it processes so as to reduce the amount of data traffic to a subscriber

Note 1 to entry: All SIRI subscriptions for a Subscriber are automatically assigned to a Subscriber Channel. The subscriptions in a channel are mediated collectively; if a Situation affects more than one subscription within a channel, only a single notification is sent to the subscriber. The resulting delivery contains all updates for all subscriptions in the channel. There is at least one subscriber channel per Subscriber; some implementations may allow more than one channel for a given subscriber.

3.2.61

subscriber reference – SIRI

Participant Reference, i.e. identifier of a Participant acting as a Subscriber: It provides a unique scope for the MESSAGE REFERENCE

3.2.62

subscription manager – WS-PubSub

service that allows a Service requestor to create and manipulate Subscription Resources; a Subscription manager is subordinate to the Notification Producer and may be implemented by the Notification Producer service, or separately as desired. In SIRI only limited capabilities to manage subscriptions are provided

3.2.63

subscription reference – WS-PubSub

identifier issued to identify a subscription, and subsequently used to refer to it in further exchanges within the Publish/Subscribe stateful resource pattern

Note 1 to entry: In SIRI, the Subscription Reference comprises two parts: the Subscriber Reference (i.e. the Participant Code of the subscriber), and the Subscription Identifier: unique within the scope of a Participant Reference. Subscriber References are issued by a Subscriber in SIRI, not the Producer.

Formally in WS-PubSub, a subscription reference is a WS resource returned in a Subscription Response containing the address of the Subscription Manager, and the Subscription Identifier. In SIRI the address of the Subscription Manager is obtained indirectly.

3.2.64

subscription request – WS-PubSub

message from the Subscriber client to the Notification Producer to create a Subscription

Note 1 to entry: In SIRI a Subscription Request contains one or more SIRI Functional Service Subscription Requests.

3.2.65

subscription response – WS-PubSub

Delivery from the Server to the Client, returned in response to a Subscription Request; either confirming the creation or other change to a Subscription, or giving an Error Condition

3.2.66

subscription policy – WS-PubSub

terms regulating the processing of a Subscription, for example how often entries should be returned

3.2.67

service subscription request – SIRI

service Subscription Request specifies the specific SIRI Functional Service for which the Subscription Request is made

Note 1 to entry: SIRI Functional Service Subscription Requests have the form XxxSubscriptionRequest and are always embedded in a Subscription Request.

3.2.68

subscription termination – WS-PubSub

request from the Client to the Server to close a Subscription

3.2.69

topic – WS-PubSub

concept used by a Notification Producer to categorize Notification Messages to decide which Subscribers should be sent a Notification

Note 1 to entry: A Subscriber specifies which Topics it is interested in as part of its Subscription Request.

3.2.70

transport layer – SIRI

separate layer of the implementation concerned with the physical transport of messages over communications protocols (http POST, SOAP, TCP/IP Sockets, etc.)

Note 1 to entry: Although http POST is the currently preferred method by most implementers, SIRI is intended to be independent of any particular communications transport protocol, and the information needed to establish a binding to a protocol, for example endpoint addresses, shall be explicitly specified in a form that can be accessed by different protocols.

3.2.71

ws-resource – WS-PubSub

resource such as a Subscription that is used to support a stateful pattern of interaction shall have certain characteristics, such as an endpoint reference, with which Consumer and Notification Producer can agree to refer to the resource, and an address to which Notification message can be sent

Note 1 to entry: WS-PubSub indicates what these characteristics and equivalent elements are present in SIRI: note however that for some SIRI implementations, some resource properties may be specified statically in the configuration, rather than being specified dynamically on each individual message.

4 Symbols and abbreviations

API	Application Programming Interface
AVL	Automated Vehicle Location
AVMS	Automated Vehicle Management System
HTTP	HyperText Transfer Protocol
IETF	Internet Engineering Task Force
ISO	International Standards Organisation
RPC	Remote Procedure Call
PTAN	Public Transport Access Node
PTV	Passenger Transport Vehicle
RTI	Real-Time Information
RTIG	Real-Time Interest Group (UK)
SIRI	Service Interface for Real-time Information
SOAP	Simple Object Access Protocol
TRIDENT	TRansport Intermodality Data sharing and Exchange NeTworks

UML	Unified Modelling Language
URI	Uniform Resource Identifier
URL	Universal Resource Locator
VDV	Verband Deutscher Verkehrsunternehmen (D)
W3C	World Wide Web Consortium
WGS	World Geodetic Standard
WS	Web Service
WSDL	Web Services Description Language
XHTML	eXtensible Hyper Text Mark-up Language
XMI	XML Metadata Interchange
XML	eXtensible Mark-up Language
XSD	XML Schema Document
XSLT	XSL Transformations Language

5 Types of reference data used in SIRI

5.1 General

The exchange of data between two systems requires that both systems can refer to data instances unambiguously. In SIRI, this involves the use of a number of concrete DATA REFERENCE systems to specify the scope and nature of the identifiers of the different types of entity that appear as elements in interfaces, for example LINES, Vehicle STOP POINTS, DIRECTIONS and Vehicle Features. Table 1 summarizes these entities.

Two features need to be specified for each data reference system: a data model and an identifier scope (i.e. a namespace for the allocation of identifiers within the model).

Some data elements, such as time, can be assigned a universal scope, other namespaces such as product references, need to be mutually agreed between communicating pairs of systems, and will be specific to their implementations.

Those data systems that need to be agreed for SIRI fall into two groups:

- Simple models, for which there is an exactly equivalent entity in both systems, for which only the namespace and identifier element needs to be agreed.
- Complex models, where not only the namespace, but also the submodel needs to be agreed – for example the stop and place location model.

In the latter case it is desirable to try and reduce the model to a simple reference if possible.

Table 1 — Data References for SIRI

Reference Data	Type	SIRI XML Element	Scope	Basis	Discovery
Date & Time	Simple	<i>xsd:dateTime</i>	Universal	ISO 8601	--
Language	Simple	<i>xml:language</i>	Universal	ISO 639-1	--
Location	Complex	<i>LocationStructure</i>	Universal	WGS84 / gml	--
Information Provider	Simple	<i>ParticipantRef</i>	Participants, Regional?	agreement	--
Stop Point Model	Complex	<i>StopPointRef</i>	Participants, Arbitrary	data	Yes
Monitoring Point Model	Complex	<i>MonitoringRef</i>	Participants, Arbitrary	data	Yes
Connection Point Model	Complex	<i>ConnectionLinkRef</i>	Participants, Arbitrary	data	Connection Service
VehicleActivity Model	Complex	<i>VehicleMonitoringRef</i>	Participants, Arbitrary	data	--
Vehicle Journey	Simple	<i>VehicleJourneyRef</i>	Participants, Arbitrary	data	Timetable Service
Stop Visit In Pattern	Simple	<i>VisitNumber</i>	Vehicle Journey, Integer	data	Journey Pattern
Line	Simple	<i>LineRef</i>	Participants, Arbitrary	data	Yes
Direction	Simple	<i>DirectionRef</i>	LineRef, Arbitrary	SIRI Recommended values	(Line)
Destination	Simple	<i>DestinationRef</i>	Participants, Arbitrary	data	
Schedule Version	Simple	<i>ScheduleVersionRef</i>	Participants, Arbitrary	data	Timetable
Product Category	Simple	<i>ProductCategoryRef</i>	Participants, Arbitrary	SIRI Recommended values	Yes
Vehicle Feature	Simple	<i>VehicleFeatureRef</i>	Participants, Arbitrary	SIRI Recommended values	Yes
Service Feature	Simple	<i>ServiceFeatureRef</i>	Participants, Arbitrary	SIRI Recommended values	Yes

The Participant Reference is used as a general purpose Namespace for data references. The Participant Reference of each system communicating with SIRI messages shall be unique, and so provides a guaranteed unique scope both for message and subscription identifiers, and for data element types originating from a given system.

Discovery services may be provided to reveal to subscribers and requestors the allowed values of reference data that may be used in requests. Alternatively this may be previously agreed and manually configured.

Note 1 to entry: NeTEx introduces a uniform approach to name spaces that may also be used in SIRI. Elements are prefixed with a XSD namespace prefix, declared at the beginning of the document. For example:

```
<Siri .... xmlns:napt="http://www.naptan.org.uk/naptan/ "
.....
    <MonitoringRef>napt:470034566</MonitoringRef>
```

5.2 Date and time format

All timestamps are stated in UTC (Coordinated Universal Time). The use of UTC avoids problems with changeover between summer and winter time zones. Differences from the UTC time zone are coded in accordance with ISO 8601 (e.g.: 2000-04-07T18:39:00+01:00).

In accordance with ISO 8601, if no time difference is given, the time is in UTC; this may be further indicated by the presence of a Z suffix (2002-04-30T12:00:00 corresponds to 2002-04-30T12:00:00Z). In other words, the first 19 characters are obligatory and correspond to local time or UTC.

Time units less than one second are ignored.

```
<ExpectedDepartureTime>2001-12-17T09:30:47-05:00</ExpectedDepartureTime>
```

5.3 Location coordinate system

A number of the SIRI functional services include geospatial point coordinates among their response data, for example for the positions of moving PT vehicles. The actual coordinate system to be used is parameterized: SIRI supports the Geographic Mark-up Language (GML) coordinate formats and data reference systems. The following example shows the encoding of a point for a vehicle LOCATION, using *epsg: 4326* as indicated by the **srsName** attribute.

```
<VehicleLocation srsName="epsg:4326">  
  <Coordinates>52.5600 3.000012</Coordinates>  
</VehicleLocation>
```

Note that a default value for the **srsName** attribute may be set on the delivery header, or request context, to apply to all points in the response, and so does not need to be repeated on individual points (though it can be if wished, as shown in the example above). Points may also be assigned an identifier.

```
<ServiceDelivery srsName="epsg:4326">  
...  
  <VehicleLocation id="point96"  
    <Coordinates>52.5600 -3.000012</Coordinates>  
  </VehicleLocation>
```

The SIRI encoding uses tags and attributes in the SIRI namespace that correspond exactly to equivalents in the GML namespace. The following example shows an equivalent GML encoding.

```
<gml:location>  
  <gml:Point gml:id="point96" srsName="epsg:4326">  
    <gml:coordinates>52.5600 -3.000012</gml:coordinates>  
  </gml:Point>  
</gml:location>
```

As an optimization, an alternative encoding is also supported in SIRI: this is an efficient, fixed mark-up comprising a pair of explicit **Latitude** and **Longitude** elements, stated in WGS 84 (World Geodetic System 1984) decimal degrees of arc. This encoding is used as a default in SIRI, and allows the validation of the coordinates to be enforced by the schema validator (for a parameterized gml coordinate system, validation shall otherwise be enforced by the application according to the **srsName** parameter).

```
<VehicleLocation>  
  <Longitude>-3.000012</Longitude>  
  <Latitude>52.5600 <Latitude >  
</VehicleLocation>
```

The above optimised SIRI encoding is equivalent to a general gml:coordinates format encoding:

```

<gml:location>
  <gml:Point gml:id="point96" srsName="epsg:4326">
    <gml:coordinates>52.5600 -3.000012</gml:coordinates>
  </gml:Point>
</gml:location>

```

5.4 National language of text elements

5.4.1 General

In accordance with standard W3C usage, text elements may include an *xml:lang* attribute to indicate the language in which a string is specified. ISO standard language values should be used to indicate the specific languages, see ISO 639-1 and RFC 1766.

In SIRI a Natural Language Data type, which is a string incorporating the XML lang attribute, is used for text elements that may be in different languages. For example:

- `<Name lang="de">München, Hauptbahnhof</Name>`
- `<Name lang="fr">Munich Gare Centrale</Name>`
- `<Name lang="en">Munich Main Station</Name>`

5.4.2 Model

Two character ISO Language code.

5.4.3 Namespace and scope

Global namespace as per ISO 639-1.

5.5 Participant (information provider) identification

5.5.1 General

In order to be able to distinguish between the messages from different communicating partners using a service, a unique scope of reference is needed. This scope is indicated in each message by a unique Participant Reference for each participant, using a Participant Code mutually agreed between the participating systems, and which forms part of the unique message reference. The Participant Reference also provides a default scope for all other data references originated from the participant.

5.5.2 Model

Single scope, the *ParticipantRef*. shall be unique to each system in the network.

5.5.3 Namespace and scope

The Participant Reference is unique between any pair of communicating SIRI participants.

5.6 Participant pair identification (service participant pair code)

5.6.1 General

If necessary, the agreed set of unique identifiers for some or all data references may be specific to the interaction of a pair of participants. That is to say a separate Participant Pair Code may be created (as

opposed to the actual Participant Codes of either Participant) to serve as a Namespace that is unique to the interaction of the two parties for a specific service. Both Participants may then map the data values to their own internal identifiers.

5.6.2 Model

The Participant Pair have a single scope, the *ParticipantPairRef*. This will either be the *ParticipantRef* of the Producer system, or a more specific mutually agreed scope.

5.6.3 Namespace and scope

Participant Pair code is unique between any pair of communicating SIRI participants.

5.7 Point and place references

5.7.1 General

Systems exchanging real-time information need a common understanding of the respective data references to places and points such as STOP POINTS, STOP AREAS and ZONES (in general in Transmodel, a place will always be represented by a POINT, but in larger interchanges such as stations and bus stances, points may also have a more elaborate submodel). The data reference systems for referring to stops inevitably vary between countries and regions in Europe and so are treated in SIRI as a pluggable feature. Each pair of participating SIRI implementations may choose both the detailed point model, and the namespace for allocating the point references which they wish to use. In practice three combinations are found.

Table 2— Examples of Point and Place Reference Scope and models

	Uniform Point Model	Alternative Point Model
Global Identifier Scope	NaPTAN (UK)	n/a
Participant Identifier Scope	TRIDENT (FR)	VDV (DE)

5.7.2 Global scope, uniform point model

There is a common model for the structure of stops and stop areas and a unique shared numbering system for all relevant locations. This allows a fixed reference system to be assumed by both parties.

5.7.3 Participant scope, uniform point model

There is a common model for the structure of stops and stop areas, but the scope of point identifiers is by agreement between the two participants, which may choose to use a scope indicated by one or other participant or even an agreed bilateral participation reference unique to the pair.

5.7.4 Participant scope, alternative point models

Both the specific reference system, and the specific stop reference model to be used, may vary by implementation (or even in theory dynamically with each request). The point model can be based on location points (e.g. stops, masts) or location areas (stop areas). The most suitable point model to choose depends on the AVMS data model as well as the specific service and data characteristics (e.g. changeover times).

As long as the two communicating systems can agree arbitrary common identifiers, direct coupling with a global reference system is not needed.

The agreements as to the point model to be used can be exclusively bilateral; within a message exchange, it is always possible to determine the communication partner. This means that all identifiers need only be

uniquely in respect of communication with each specific participant pair. A regional agreement of terms between several operators is useful, but is not essential.

For systems that need to support different varying alternative location models, the common location reference model can be agreed by prior arrangement at a provisioning conference or other similar committee meeting, and can cover both the model schema and the identifiers to be used. The agreement should be valid in the mid to long term, to minimize the necessity of data changes. The systems shall then be configured to support the agreed model, and be provisioned with a set of agreed location references that map to both parties' systems.

For systems that use a uniform point and place model, it is attractive to provision and update the systems automatically from a common reference source (which might be one or other of the participants, or an authoritative third party), without the need for extensive manual negotiation and configuration. SIRI includes an optional stop discovery protocol to do this.

Each SIRI Functional Service uses a distinct set of References to refer to the primary point or place entities that it uses, for example connections happened at connection links, timetables reference stop points. Implementers may map these to a common model and namespace if they wish. Table 3 shows the primary point references used in the respective services.

Table 3 — Examples of Point / Place References and Services

Service	Point/Place name	PointRef	VDV
Production Timetable	Scheduled Stop	<i>StopPointRef</i>	Ref-SIS
Estimated Timetable	Scheduled Stop	<i>StopPointRef</i>	SIS StopID / StopID
Stop Monitoring	Monitoring Point or Points	<i>MonitoringRef</i>	(Dynamic passenger information) Display ID/ DISID
Vehicle Monitoring	Vehicle Monitoring Scope	<i>VehicleMonitoringRef</i>	Visualisation ID / VISID
Connection Timetable	Connection Link	<i>ConnectionLinkRef</i>	Connection ID/ CPIID
Connection Monitoring	Connection Link	<i>ConnectionLinkRef</i>	Connection ID/ CPIID

The management of data – both for setup and for maintenance – is a significant cost of ownership for AVMS systems, and in the long term it will be desirable to adopt a small number of well-known stop models and stop namespaces that can be configured and provisioned readily.

5.7.5 Model

Each point may be referenced to by a unique identifier. The model underlying the point may vary for each SIRI Functional Service type and implementation pair.

5.7.6 Namespace and scope

The unique scope for referencing a point between any pair of communicating SIRI participants is given by the Service type, Participant Pair.

SiriServiceType: ParticipantPairRef: **StopPointRef**.

SiriServiceType: ParticipantPairRef: **MonitoringRef**.

SiriServiceType: ParticipantPairRef: **VehicleMonitoringRef**.

SiriServiceType: ParticipantPairRef: **ConnectionLinkRef**.

Only the last term needs to be stated explicitly in a message schema: the Service type will be given by the context, and the Participant Pair Reference will normally be given either by the configuration, or the context. Often the Participant Reference of one or other Participant will be used as the Participant Pair Reference (as in TRIDENT), or it may be global (as in NaPTAN).

5.8 Vehicle journey references

5.8.1 General

Several of the SIRI Functional Services require the representation of MONITORED VEHICLE JOURNEYS, that is, the vehicles being tracked as they enact a DATED VEHICLE JOURNEY whose full details are held in the system.

For distributed SIRI participants, the referencing of foreign vehicle journeys trips presents a similar problem to that of point and place references. The various entities that describe vehicles and their journeys, such as line / block / course of Journey do not necessarily have common identifiers on different participant systems. This means there is also no guarantee of the required uniqueness of reference.

In particular, participating systems need to be able to distinguish unique references to both:

- A VEHICLE JOURNEY, i.e. a scheduled journey in a timetable;
- A DATED VEHICLE JOURNEY, a particular instance of a vehicle making an actual journey (a DATED VEHICLE JOURNEY is associated with a timetabled VEHICLE JOURNEY).

There may be more than one DATED VEHICLE JOURNEY fulfilling the VEHICLE JOURNEY, if for example several VEHICLES are needed to carry all the expected passengers.

Within an AVMS, there is typically an internal designator that uniquely references the vehicle journey within the Participant system and its given data horizon. However, when referencing vehicles in an external system this designator alone may be insufficient to uniquely identify a vehicle, as the data horizon of the foreign operator may be unknown. It is possible that there may be two vehicle journeys of a foreign operator that would have the same internal designator in the local system even if qualified by the foreign Participant Reference: even if in the foreign AVMS they are in different operating days and so are unique, within the local operator they would lose this uniqueness without an indication of the day. Day type is therefore included in the name space.

5.8.2 Model

Each VEHICLE may be referenced to by a unique compound identifier. The identifier is made up of two terms.

5.8.3 Namespace and scope

References will be unique for each service type between any pair of communicating SIRI participants. The full name scope of VEHICLE JOURNEY references will be:

SiriServiceType: ParticipantPairRef: LineRef: DataFrameRef: VehicleJourneyRef

Where **DataFrameRef** is a qualifier that ensures that the VEHICLE JOURNEY reference is unique across different operational periods of the producer, i.e. if the same identifier is reused for different journeys in different data horizon periods, an external system can still reference the correct entity. In practice the **DayType** is often used as the **DataFrame** Identifier.

The full name scope of Dated Vehicle Journey References will be:

SiriServiceType: ParticipantPairRef: LineRef: OperatingDate: DatedVehicleJourneyRef

5.9 Line, and direction references

5.9.1 General

In order to distinguish references to LINES and the particular DIRECTIONS in which a LINE runs, separate unambiguous LINE reference, and DIRECTION reference elements are used in SIRI interfaces. These constitute a small model of related elements whose values are agreed bilaterally.

In the normalised Transmodel model, LINE and ROUTE are distinct entities: a ROUTE is for a LINE and DIRECTION is a property of ROUTE. A ROUTE is associated with a JOURNEY PATTERN, and each VEHICLE JOURNEY follows a JOURNEY PATTERN. In SIRI the JOURNEY PATTERN, LINE and DIRECTION are included as derived attributes but are not separately articulated.

5.9.2 Model

LINE is modelled with two elements in SIRI: **LineRef**, a system key which is guaranteed to be unique within a document, and that is associated with a **PublishedLineName** the public identifier, which is not necessarily unique.

A DIRECTION is a relative sense of traversal of a ROUTE (for example inbound/outbound, clockwise/anticlockwise); it is modelled in SIRI by a **DirectionRef**, which may have a **DestinationRef** associated with it.

5.9.3 Namespace and scope

The LineRef is unique within the Participant Pair. **LineRef** provides a unique scope for the **PublishedLineName**, and **DirectionRef** references:

ParticipantPairRef: **LineRef**

ParticipantPairRef: **LineRef**: **PublishedLineName**

ParticipantPairRef: **LineRef**: **DirectionRef**

5.10 Stop sequence references and circular journeys

5.10.1 General

For journey patterns with a complex topology, such as circular, cloverleaf and lollipop routes, the same stop may be visited more than once by a vehicle following the pattern. In SIRI, each Point in Journey Pattern is distinguished by a unique **VisitNumber** number. This allows services such as the SIRI Connection Monitoring service that need to refer to specific arrivals or departures of a specific journey at a specific stop to do so.

5.10.2 Model

There are two different methods commonly used to assign a unique *Stop Sequence* number for a stop within a journey pattern:

- An *order* or *sequential call number*, that is a unique positive integer that increases monotonically (but not necessarily in strict succession – some numbers may be omitted) within the whole pattern.
- A stop *visit number* that gives each successive visit to the same stop a positive integer unique within just the individual stop reference. Again the numbers are assigned monotonically, but not necessarily in strict succession.

Table 4 illustrates the two different methods: values that increase by more than one over the previous value are indicated by an asterisk: this is entirely arbitrary.

Table 4 — Example of Stop Sequence, order and Visit Numbers

Stop Point Identifier	Strict sequential order	Order in journey pattern / Sequential Number	Visit Number (within stop)	Strict Visit Count (within stop)
aaa023	1	001	1	1
b46721	2	002	1	1
C012563	3	004 *	1	1
aaa023	4	006 *	2	2
aklpou	5	008 *	1	1
b46721	6	009	2	2
aaa023	7	010	7*	3

A sequential call number will be unique with a journey pattern, and so can in principle be used as a surrogate identifier for the stop within the journey pattern: in contrast, a stop visit number cannot necessarily be used as a surrogate – it shall always be used in conjunction with a stop point identifier, as there may be several identical visit number values for different stops within the same journey pattern. *A sequential call number may thus be used as a visit number, but a visit number may not be used as a sequential visit number.*

For example, in Table 4, stop 'aaa023' is visited three times in the journey pattern as the first, fourth and seventh stop of the strict stop sequence – the three successive calls have sequential visit numbers of '001', '006' and '010' respectively, and stop visit numbers of '1', '2' and '7' respectively.

In SIRI a *stop visit number* is normally used for the sequence: in consequence SIRI implementations should therefore always assume the following:

- that only the **StopPoint** Identifier together with the **VisitNumber** number gives a unique reference for a stop within a journey pattern;
- the strict order of stops within the journey pattern is *not* given by the **VisitNumber** number (for example 'Stop A: Sequence 1', 'Stop B: Sequence 1, Stop C: Sequence:1' would be a typical set of values);
- the actual value for the **VisitNumber** number is not necessarily the strict count, even within a stop, merely a monotonically increasing integer; for example the same stop visited three times might have values '1', '3' and '5' for the first, second and third visits respectively.

Implementations may indicate that the **VisitNumber** is also an ORDER number as an optional capability. If the **VisitNumber** is not an ORDER number than a separate **Order** may be included. Table 5 shows SIRI elements that use **VisitNumber**.

Table 5 — Usages of Visit Numbers

Service Delivery	Element	Contained in	Immediate Parent Element
<i>ProductionTimetable</i>	<i>DatedTimetable</i>	<i>DatedVehicleJourney</i>	<i>DatedCall</i> <i>TargetedInterchange</i>
<i>EstimatedTimetable</i>	--	<i>EstimatedVehicleJourney</i>	<i>EstimatedCall</i>
<i>StopTimetable</i>	<i>TimetabledStopVisit</i>	<i>TargetedVehicleJourney</i>	<i>TargetedCall</i>
<i>StopMonitoring</i> <i>VehicleMonitoring</i>	<i>MonitoredStopVisit</i>	<i>MonitoredVehicleJourney</i>	<i>MonitoredCall</i>
	<i>VehicleActivity</i>		<i>PreviousCall</i>
			<i>OnwardCall</i>
	<i>MonitoredStopVisitCancellation</i>	--	-
<i>ConnectionMonitoring</i>	<i>TimetabledFeederArrival</i>	-	-
	<i>TimetabledFeederArrivalCancellation</i>	-	-
	<i>MonitoredFeederArrivalCancellation</i>	--	-

5.10.3 Namespace and scope

Visit Number instances are unique within the VEHICLE JOURNEY and SCHEDULED STOP POINT, i.e. Point in Journey Pattern.

ParticipantPairRef: VehicleJourneyRef: StopPoint: VisitNumber

5.11 Schedule version references

5.11.1 General

The timetable version denotes a specific version of a planned timetable.

5.11.2 Model

Each timetable version is represented by a *TimetableVersionRef* element.

5.11.3 Namespace and scope

Schedule versions are unique within Participant Pair:

ParticipantPairRef: TimetableVersionRef

5.12 Product category references

5.12.1 General

Within the interface, unambiguous references may sometimes be needed to product types in order to be able to present product names consistently to the passenger (as both text, and icons) in services that span different operational servers, in particular for connection and stop monitoring information. PRODUCT CATEGORIES serve to classify the VEHICLE JOURNEYS within a given TRANSPORT MODE. Examples of product categories include “Intercity train”, “Slow train”, “express bus”, etc. As yet, there is no common standard for product classification.

PRODUCT CATEGORIES are also useful for splitting the journeys into fare-based structures, or for modelling default changeover times (“The monthly pass is valid on all local buses and underground trains” or

“Changeover time between the long distance trains and city buses is 5 min, unless otherwise indicated at the stops”).

5.12.2 Model

Each PRODUCT CATEGORY is represented by a **ProductCategoryRef**.

5.12.3 Namespace and scope

Product categories identifiers are unique within Participant Pair:

ParticipantPairRef: ProductCategoryRef

5.12.4 Recommended values

5.12.4.1 General

Recommend values for product categories based on TPEG are shown in the following tables.

5.12.4.2 Transport submode (TPEG Pti01 transport_mode transport_submode)

Table 6 — Product Category: Transport Submodes

TPEG 100	TPEG PTI id	TPEG Loc05	SIRI Mode name	SIRI Submode	TPEG Submode
Tpeg100_0	pti01_0	loc05_0	<i>unknownSubmode</i>	--	--
Tpeg100_6	pti01_1	loc05_2	<i>railwayServiceSubmode</i>	Rail	pti02_x
Tpeg100_23	pti01_2	loc05_3	<i>coachServiceSubmode</i>	Coach	pti03_x
Tpeg100_24	pti01_3	loc05_4	<i>suburbanRailwayServiceSubmode</i>	--	--
Tpeg100_32	pti01_4	--	<i>urbanRailwayServiceSubmode</i>	Metro	pti04_x
Tpeg100_8	pti01_5	loc05_16	<i>metroServiceSubmode</i>	--	--
Tpeg100_7	pti01_6	loc05_5	<i>undergroundServiceSubmode</i>	--	--
Tpeg100_1	pti01_7	loc05_6	<i>busServiceSubmode</i>	Bus	pti05_x
Tpeg100_31	pti01_8	--	<i>trolleyBusServiceSubmode</i>	--	--
Tpeg100_5	pti01_9	loc05_7	<i>tramServiceSubmode</i>	Tram	pti06_x
Tpeg100_13	pti01_10	loc05_8	<i>waterTransportServiceSubmode</i>	--	pti07_x
Tpeg100_25	pti01_11	loc05_9	<i>airServiceSubmode</i>	Air	pti08_x
Tpeg100_9	pti01_12	--	<i>ferryServiceSubmode</i>	--	--
Tpeg100_17	pti01_13	loc05_10	<i>telecabinServiceSubmode</i>	--	pti09_x
Tpeg100_18	pti01_14	loc05_11	<i>funicularServiceSubmode</i>	--	pti10_x
Tpeg100_20	pti01_15	loc05_12	<i>taxiServiceSubmode</i>	--	pti11_x
Tpeg100_26	pti01_16	loc05_13	<i>selfDriveSubmode</i>	--	pti12_x
Tpeg100_22	pti01_17	--	<i>allServicesSubmode</i>	--	--
Tpeg100_11	--	--	<i>parkAndRide</i>	--	--
Tpeg100_21	--	--	<i>roadTransport</i>	--	--
Tpeg100_29	--	loc05_14	<i>cableDrawnBoat</i>	--	--
Tpeg100_27	--	loc05_15	<i>monoRail</i>	--	--
--	pti01_18	loc05_255	<i>allServicesExceptSubmode</i>	--	--

5.12.4.3 Rail submode (TPEG Pti02 railway_type)

Table 7 — Product Category: Rail Submodes

TPEG pti02	TPEG loc13	SIRI name
pti02_0	loc13_0	<i>unknownRailwayType</i>
pti02_1	--	<i>highSpeedRailService</i>
pti02_2	loc13_3	<i>longDistanceTrain</i>
pti02_3	loc13_2	<i>interRegionalRailService</i>
pti02_4	--	<i>carTransportRailService</i>
pti02_5	--	<i>sleeperRailService</i>
pti02_6	loc13_4	<i>regionalRail</i>
pti02_7	loc13_7	<i>touristRailway</i>
pti02_8	--	<i>railShuttle</i>
pti02_9	loc13_5	<i>suburbanRailway</i>
pti02_10	--	<i>replacementRailService</i>
pti02_11	--	<i>specialTrainService</i>
pti02_12	--	<i>lorryTransportRailService</i>
pti02_13	--	<i>allRailServices</i>
pti02_14	--	<i>crossCountryRailService</i>
pti02_15	--	<i>vehicleRailTransportService</i>
pti02_16	loc13_8	<i>rackAndPinionRailway</i>
pti02_17	--	<i>additionalTrainService</i>
(pti02_9)	loc13_6	<i>local</i>
(pti02_3)	loc13_1	<i>international</i>
pti02_255	--	<i>undefinedRailService</i>

5.12.4.4 Coach submode (TPEG Pti03 coach_type)

Table 8 — Product Category: Coach Submodes

TPEG Pti3	SIRI Name
pti3_0	<i>unknownCoachType</i>
pti3_1	<i>internationalCoachService</i>
pti3_2	<i>nationalCoachService</i>
pti3_3	<i>shuttleCoachService</i>
pti3_4	<i>regionalCoachService</i>
pti3_5	<i>specialCoachService</i>
pti3_6	<i>sightseeingCoachService</i>
pti3_7	<i>touristCoachService</i>
pti3_8	<i>commuterCoachService</i>
pti3_9	<i>allCoachServices</i>
pti3_255	<i>undefinedCoachService</i>

5.12.4.5 Metro submode (TPEG Pti04 urban_railway_type / Loc11 metro rail link)

Table 9 — Product Category: Metro Submodes

TPEG Pti04	TPEG Loc11	SIRI Name
pti04_0	pti111_0	<i>unknownUrbanRailwayType</i>
pti04_1	pti111_3	<i>Metro</i>
pti04_2	pti111_1	<i>Tube</i>
pti04_3	pti111_2	<i>urbanRailway</i>
pti04_4	--	<i>allUrbanRailwayServices</i>
--	pti111_4	<i>airportRailLink</i>
--	pti111_5	<i>monoRailLink</i>
pti04_255	pti111_255	<i>undefinedUndergroundService</i>

5.12.4.6 Bus submode (TPEG Pti05 bus_type)

Table 10 — Product Category: Bus Submodes

TPEG Pti05	TPEG Loc10	SIRI Name
pti05_0	loc10_0	<i>unknownBusType</i>
pti05_1	loc10_6	<i>regionalBus</i>
pti05_2	loc10_1	<i>expressBus</i>
pti05_3	--	<i>Bus</i>
pti05_4	loc10_5	<i>localBusService</i>
pti05_5	loc10_2	<i>nightBus</i>
pti05_6	loc10_4	<i>postBus</i>
pti05_7	loc10_8	<i>specialNeedsBus</i>
pti05_8	--	<i>mobilityBus</i>
pti05_9	--	<i>mobilityBusForRegisteredDisabled</i>
pti05_10	loc10_9	<i>sightseeingBus</i>
pti05_11		<i>shuttleBus</i>
pti05_12	loc10_7	<i>schoolBus</i>
pti05_13	loc10_3	<i>schoolAndPublicServiceBus</i>
pti05_14	--	<i>railReplacementBus</i>
pti05_15	--	<i>demandAndResponseBus</i>
pti05_16	--	<i>allBusServices</i>
(pti05_11)	loc10_10	<i>airportLinkBus</i>
pti05_255	loc10_255	<i>undefinedBusService</i>

5.12.4.7 Air submode (TPEG Pti08 air_type)

Table 11 — Product Category: Air Submodes

TPEG Pti8	TPEG Loc15	SIRI Name
pti8_0	loc15_0	<i>Unknown</i>
pti8_1	loc15_2	<i>internationalFlight</i>
pti8_2		<i>domesticFlight</i>
pti8_3	loc15_1	<i>intercontinentalFlight</i>
pti8_4	loc15_4	<i>domesticScheduledFlight</i>
pti8_5	loc15_9	<i>shuttleFlight</i>
pti8_6	loc15_5	<i>intercontinentalCharterFlight</i>
pti8_7	loc15_6	<i>internationalCharterFlight</i>
pti8_8		<i>roundTripCharterFlight</i>
pti8_9	loc15_8	<i>sightseeingFlight</i>
pti8_10	loc15_10	<i>helicopterService</i>
pti8_11	loc15_7	<i>domesticCharterFlight</i>
pti8_12		<i>SchengenAreaFlight</i>
pti8_13		<i>airshipService</i>
pti8_14		<i>allAirServices</i>
(pti8_1)	loc15_3	<i>shortHaulInternationalFlight</i>
pti8_255	loc15_255	<i>undefinedAircraftService</i>

5.13 Vehicle feature references

5.13.1 General

The vehicle feature is used to describe the level of equipment in the vehicle. Within a city bus line for example, the individual vehicle journeys can be served by buses with very different features. For example, for people in wheelchairs or mothers with prams, it is important to know whether there is a ramp or lift, or whether the bus is a low-floor bus offering easy access.

5.13.2 Model

Each vehicle feature is represented by a **VehicleFeatureRef** element.

5.13.3 Namespace and scope

Vehicle Features are unique within Participant Pair:

ParticipantPairRef: VehicleFeatureRef

5.13.4 Recommended values

A set of recommended values for Vehicle Features are shown in Table 12 (following two pages). These values are encoded in the siri_facilities.xsd package. Some features may also be relevant as service features.

5.14 Service features

5.14.1 General

Service features are used to classify services as having particular properties of interest to the travelling public, for example, 'school bus', 'shuttle service', 'museum bus', etc.

Table 12 — Some Recommended Vehicle Feature Values

Type	TPEG Pti23	Feature	Vehicle	Service	Stop
	Pti23_0	<i>Unknown</i>	Y	Y	y
FareClass	Pti23_6	<i>firstClass</i>	Y	Y	y
	Pti23_7	<i>secondClass</i>	Y	Y	y
	Pti23_8	<i>thirdClass</i>	Y	Y	y
	Pti23_9	<i>economyClass</i>	Y	Y	y
	Pti23_10	<i>businessClass</i>	Y	Y	y
Accommodation	Pti23_3	<i>sleeper</i>	Y	Y	--
	Pti23_4	<i>couchette</i>	Y	Y	--
	Pti23_5	<i>specialSeating</i>	Y	Y	--
	Pti23_11	<i>freeSeating</i>	Y	Y	--
	Pti23_12	<i>recliningSeats</i>	Y	Y	--
	Pti23_13	<i>babyCompartment</i>	Y	Y	--
	--	<i>familyCarriage</i>	Y	Y	--
Accessibility	Pti23_16	<i>suitableForWheelChairs</i>	Y	Y	Y
	--	<i>lowFloor</i>	Y	Y	--
	--	<i>stepFreeAccess</i>	Y	Y	Y
	--	<i>boardingAssistance</i>	Y	Y	Y
	--	<i>onboardAssistance</i>	Y	Y	--
	--	<i>unaccompaniedMinorAssistance</i>	Y	Y	Y
	--	<i>audioInformation</i>	Y	Y	Y
	--	<i>visualInformation</i>	Y	Y	Y
	--	<i>displaysForVisuallyImpaired</i>	Y	Y	Y
	--	<i>audioForHearingImpaired</i>	Y	Y	Y
	--	<i>tactilePlatformEdges</i>	--	--	Y
Luggage	--	<i>portage</i>	--	--	Y
	--	<i>baggageTrolleys</i>	--	--	Y
	--	<i>leftLuggage</i>	--	--	Y
	Pti23_17	<i>bikeCarriage</i>	Y	Y	Y
	--	<i>baggageStorage</i>	Y	Y	Y
Passenger Info	--	<i>nextStopIndicator</i>	Y	Y	--
	--	<i>stopAnnouncements</i>	Y	Y	--
	--	<i>passengerInformationFacility</i>	Y	Y	Y

Type	TPEG Pti23	Feature	Vehicle	Service	Stop
Refreshments	Pti23_1	<i>restaurantService</i>	Y	Y	Y
	Pti23_2	<i>snacksService</i>	Y	Y	Y
	--	<i>trolley</i>	Y	Y	Y
	Pti23_18	<i>bar</i>	Y	Y	Y
	Pti23_19	<i>foodNotAvailable</i>	Y	Y	Y
	Pti23_20	<i>beveragesNotAvailable</i>	Y	Y	Y
	Pti23_26	<i>bistro</i>	Y	Y	Y
Nuisance	--	<i>smoking</i>	Y	Y	Y
	--	<i>noSmoking</i>	Y	Y	Y
	--	<i>mobileUseZone</i>	Y	Y	Y
	Pti23_24	<i>mobilePhoneFreeZone</i>	Y	Y	Y
Sanitary	Pti23_22	<i>toilet</i>	Y	Y	Y
	Pti23_23	<i>noToilet</i>	Y	Y	Y
	Pti23_21	<i>shower</i>	Y	Y	Y
	Pti23_22	<i>wheelchairAccessToilet</i>	Y	Y	Y
	Pti23_23	<i>babyChange</i>	Y	Y	Y
	--	<i>undefinedServiceFacility</i>	Y	Y	Y
Comms Services	Pti23_21	<i>Telephone</i>	Y	Y	Y
	--	<i>passengerWifi</i>	Y	Y	Y
	Pti23_14	<i>audioServices</i>	Y	Y	Y
	Pti23_15	<i>videoServices</i>	Y	Y	Y
	Pti23_25	<i>businessServices</i>	Y	Y	Y
Hire	--	<i>carHire</i>	--	--	Y
	--	<i>Taxi</i>	--	--	Y
	--	<i>cycleHire</i>	--	--	Y
Ticketing	--	<i>ticketMachines</i>	--	Y	Y
	--	<i>ticketOffice</i>	--	--	Y
	--	<i>ticketCollection</i>	--	--	Y
	--	<i>centralReservations</i>	--	--	Y
	--	<i>ticketOnDemandMachines</i>	--	--	Y
	--	<i>ticketSales</i>	--	Y	Y
	--	<i>mobileTicketing</i>	--	Y	Y

5.14.2 Namespace and scope

Service Features are unique within Participant Pair

ParticipantPairRef: **ServiceFeatureRef***

5.14.3 Recommended values

A set of recommended values for Service Features are shown in Table 12.

5.15 Situation references

5.15.1 General

Some SIRI response elements may include a reference to a SITUATION element that provides a structured model for describing the cause and effect of an incident or event associated with a SIRI monitored element such as a **MonitoredCall** or **VehicleJourney**. The structure of the SITUATION model is outside the scope of SIRI. The name space scope of Situation Identifiers will normally be that of the Participant System.

SIRI responses do not cover fare information or fare easements during disruptions: such data may be included either within an **Extension** tag, or as part of the SITUATION model referenced through a **SituationRef**.

5.15.2 Model

SituationRef is used to represent a reference to a SITUATION.

SituationRef instances may currently be associated with the following SIRI elements:

- EstimatedVehicleJourney,
- EstimatedCall,
- MonitoredVehicleJourney,
- MonitoredCall,
- FeederJourney,
- DistributorJourney,
- GeneralMessage,
- LineNotice.

5.15.3 Namespace and scope

SituationRef is unique between any pair of communicating SIRI participants.

ParticipantRef. SituationRef

5.16 Summary of data reference scopes

Within SIRI, message identifiers are always scoped within the Service Type and Participant (Participant References may be global or local). Data references may be variously scoped; if necessary the scope can be specific to a Pair of Participants, or it may be more general. Table 13 summarizes the likely possible scopes for different references; thus for example language references have only a global scope vehicle Features may be given either a participant or participant pair scope.

Table 13 — Possible Scopes for References

	Entity	Global	Participant	Participant Pair
Message Identity	Service Type	X	-	-
	Participant	X	X	-
	Message Reference	-	Timestamp	-
Data	Language	Y	-	-
	Monitoring Point	X	X	X
	Vehicle Monitoring Area	X	X	-
	ConnectionLink	-	X	X
	InterchangeLink	-	X	X
	StopPoint	X	X	X
	Vehicle Journey	-	X	X
	Line	-	X	X
	Journey Pattern	-	X	X
	Route	-	X	X
	Direction	X	X	X
	Destination	-	X	X
	Schedule Version	-	X	X
	Product Category	X	X	X
	Vehicle Feature	X	X	X
Service Feature	X	X	X	
Situation	X	X	X	

5.17 Transmodel compliant models

SIRI assumes a Transmodel compliant logical model to the underlying data that is exchanged in SIRI message payload content, and uses existing Transmodel terms where available for the SIRI elements based on Transmodel submodels, in particular for Network Topology, Timetable, Real-time data, and Control Actions.

Transmodel entities are generally represented by distinct elements in SIRI. However, for efficiency, in some cases the SIRI interfaces compounds into a single interface element several entities that are normalized in Transmodel into several distinct concepts. When this is done, care is taken to remain isomorphic with the underlying Transmodel model, so that mapping to a normalized implementation model is straightforward. In particular:

- Transmodel provides separate entities for LINE, ROUTE JOURNEY PATTERN and VEHICLE JOURNEY. This part of the Transmodel model is not fully articulated in SIRI; reference is always explicitly to a VEHICLE JOURNEY, and it is assumed that participant systems are able to associate the **VehicleJourney** with an appropriate JOURNEY PATTERN and hence the ROUTE and LINE details if they wish. For convenience, in addition to the JOURNEY PATTERN Identifier (**JourneyPatternRef**) and Route Identifier (**RouteRef**), certain attributes which can be derived through the association with a Journey Pattern are optionally included in SIRI as elements in the SIRI **VehicleJourney** representation: (i) from LINE the **ModeRef**, **LineRef** and **PublishedLineName**, and (ii) from ROUTE: the **RouteRef**, **DirectionRef** and **DirectionName**.
- For efficiency, SIRI introduces the concept of a **Call** entity that aggregates a number of Transmodel entities, such as STOP POINT IN SEQUENCE, and various types of PASSING TIME into a single

artefact to use exchanging SIRI Vehicle Journey details. There are several variants on this **DatedCall**, **MonitoredCall** etc.. SIRI also supports the use of a variant on the order number to sequence calls – see Stop **VisitNumber** below.

5.18 Modelling vehicle journeys in SIRI

5.18.1 General

Many of the SIRI Functional Services are concerned with exchanging the specific details of vehicle journeys, or changes to vehicle journeys, and SIRI uses an integrated representation to model the structure and various properties of journeys across different SIRI functional services, with a common data value inheritance model for defaulting properties from the base timetable to the real-time instances. This allows for the efficient transmission of data, *as only differences to previously established base points need to be exchanged*.

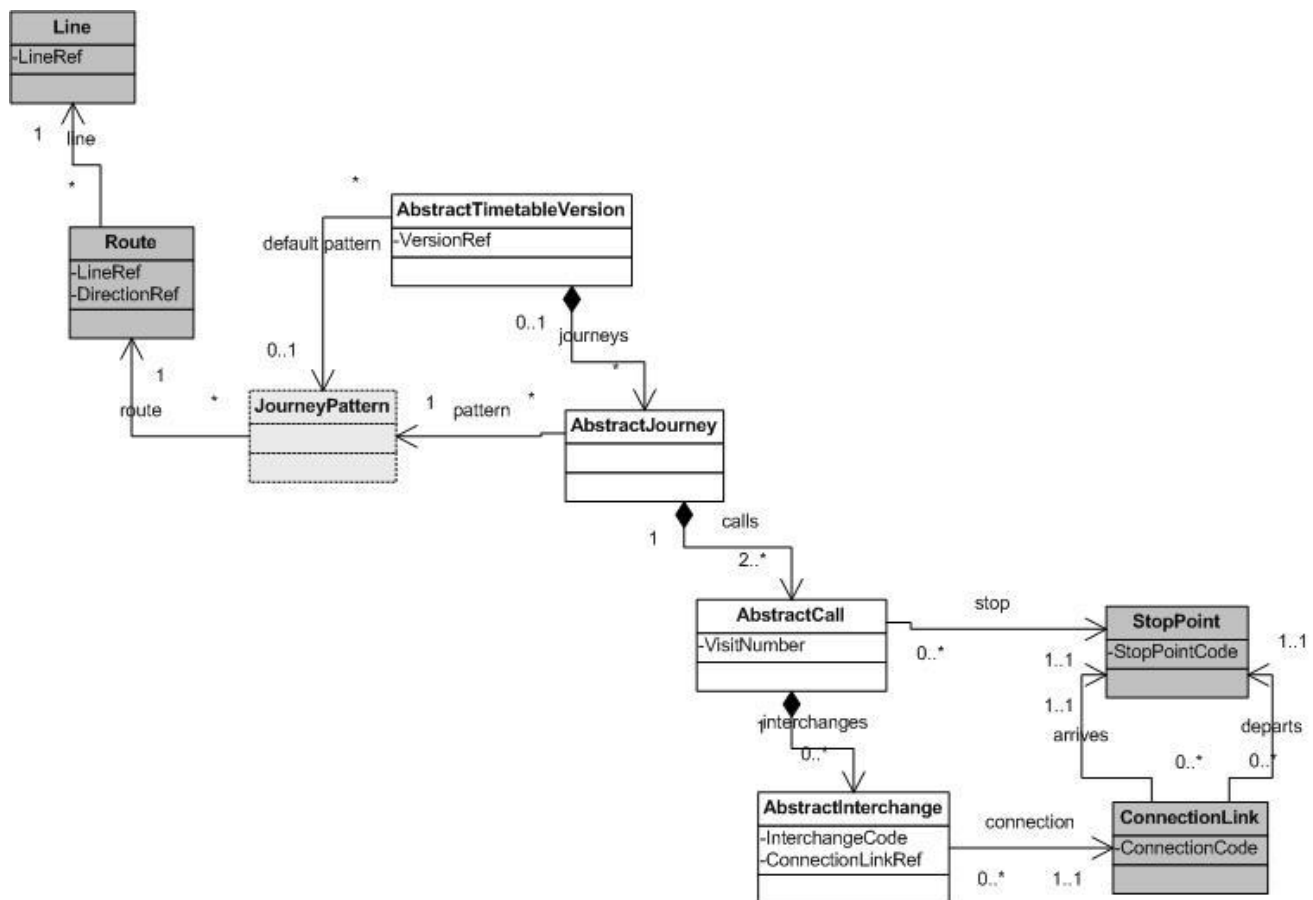

Figure 2 — UML Diagram of SIRI Abstract Journey Model

In essence there are four levels to the journey model:

- Timetable Version,
- VEHICLE JOURNEY / SERVICE JOURNEY,
- CALL,
- SERVICE JOURNEY INTERCHANGE.

Thus a timetable contains one or more journeys, and a journey contains one or more CALLs. LINE, ROUTE and JOURNEY PATTERN entities are not explicitly exposed in the SIRI interface; however certain line and direction attributes (which can be derived from the journey pattern of a journey) are included for convenience. The SIRI journey elements can thus be regarded as views of journeys in the underlying reference data model.

Each CALL in effect references a SCHEDULED STOP POINT, and may have incoming feeder arrivals and outbound distributor departures (see Figure 3 below).

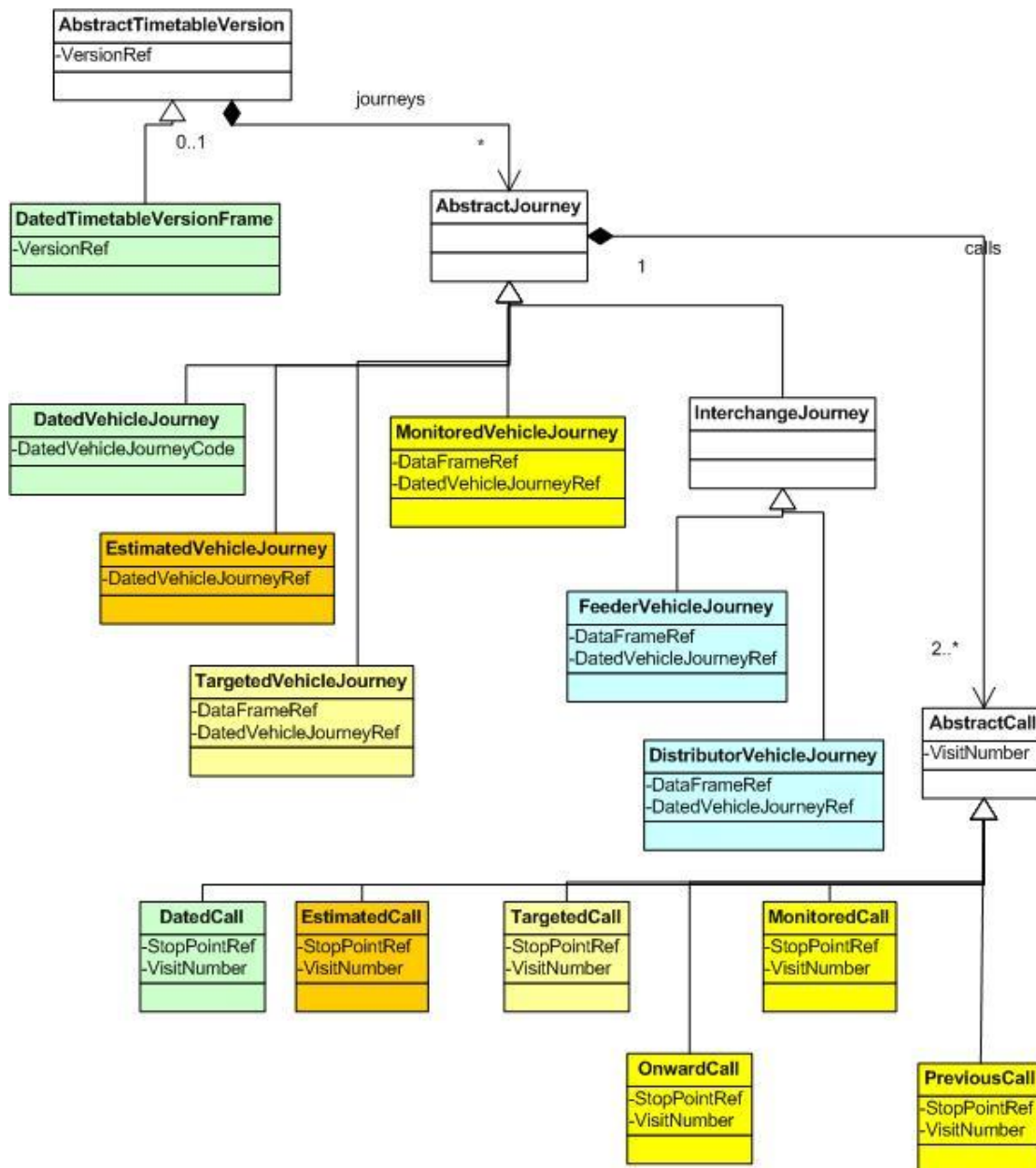

Figure 3 — UML Diagram of Concrete Journey Model

Different SIRI Functional Services can specify journeys in terms of this basic model as follows (see Figure 4 below):

- The SIRI Production Timetable Service defines a **DatedTimetable**, made up of one or more **DatedVehicleJourney** instances, each comprising two or more **DatedCall** instances, in order of

execution. **DatedCall** instances may have **TargetedInterchange** instances which describe planned connections between journeys.

- The SIRI Estimated Timetable Service exchanges **EstimatedVehicleJourney** instances, composed from zero or more **EstimatedCall** instances indicating the calls of the journey, in strict order. An **EstimatedVehicleJourney** may reference a **DatedVehicleJourney** and specify just those journeys, or just those calls in those journeys, that are different from those in the previously issued Production Service **DatedTimetable**. Properties are assumed to be the same in the real-time journey as in the planned journey, unless explicitly overridden.
- The SIRI Stop Monitoring and Product Service both return **MonitoredVehicleJourney** instances, containing variously **PreviousCall**, current **MonitoredCall**, and **OnwardCall** instances, each of which has slightly different properties. Again both journey and call may reference the respective **EstimatedVehicleJourney** or **EstimatedCall** instances, and will inherit any inheritable properties that are not explicitly overridden. Compared to a timetabled VEHICLE JOURNEY, a MONITORED VEHICLE JOURNEY is positional: it entails the concept of the VEHICLE being located at any time a point relative to its route, and consequently the calls are partitioned into sets of previous, current and onward CALLS, reflecting slight differences in what is meaningful as data for CALLS that lie in the past, present or future.

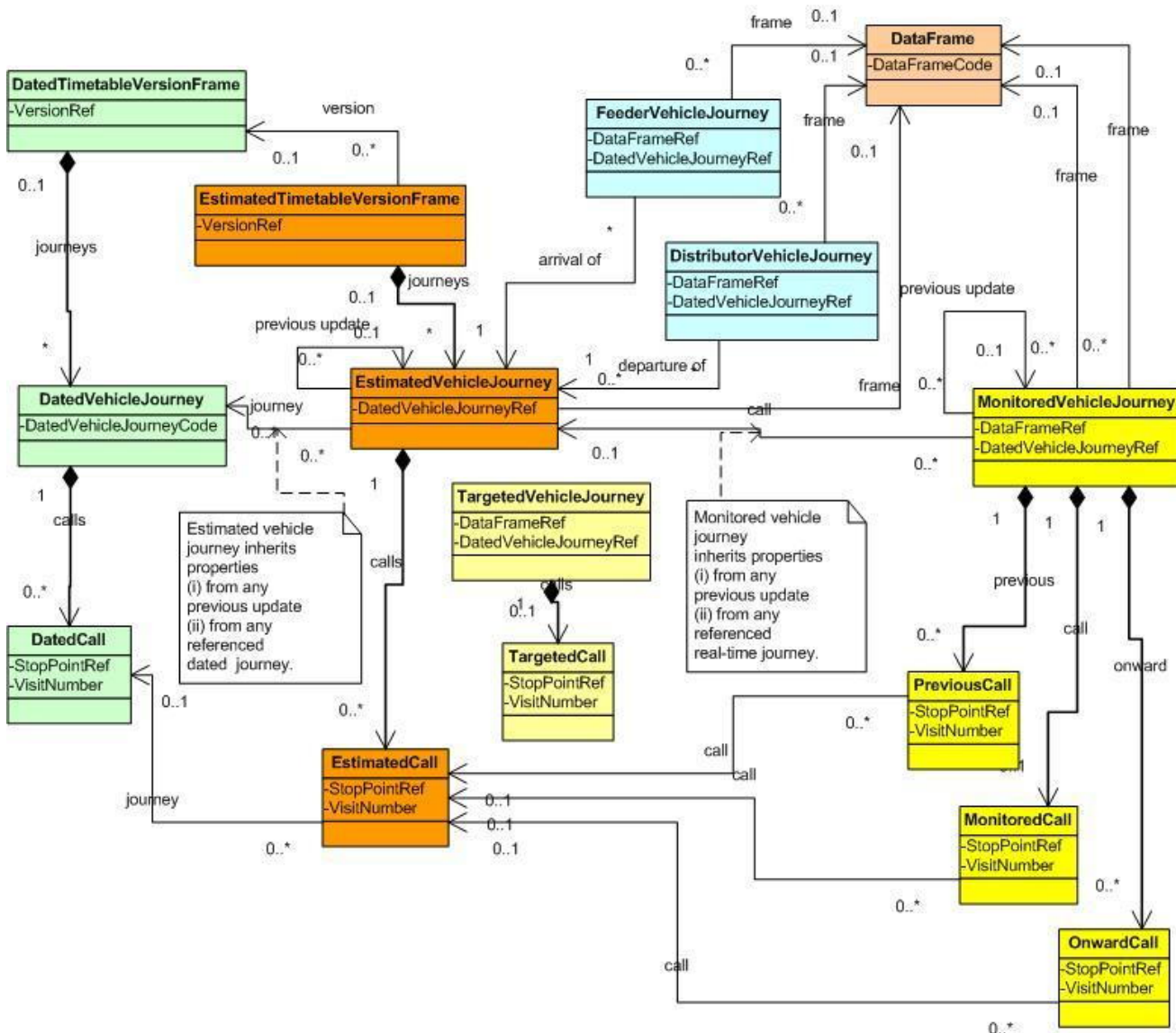

Figure 4 — UML Diagram of Concrete Journey Models showing Inheritance of Properties

- The SIRI Connection Timetable Service exchanges **FeederArrival** instances for **FeederJourney** and **DistributorJourney** instances, both of which share a common **ConnectingJourney** structure, and which can reference **DatedVehicleJourneys**. The SIRI Connection Monitoring Service exchanges **MonitoredFeederArrival** instances, and other events affecting incoming and outgoing journeys.

A number of properties and associations can be set on a **DatedTimetable**, and are assumed for all journeys and calls based on that timetable, unless explicitly overridden by an individual element. For example, the **PublishedLineName**, or the **Monitored** properties can be set on the timetable and the default values are then assumed for all journeys based on the timetable unless overridden. Similarly a target arrival time can be set on a **DatedCall** and overridden on a real-time or monitored call.

5.18.2 Element equivalences and inheritance – timetable & journey

The properties of the different types of SIRI journeys are shown in Table 14. ‘R’ indicates a required value. ‘O’ indicates an optional value. Optional values that are inherited if not specified are indicated by an ‘→O’. ‘I’ indicates a value that is inherited and cannot be overridden.

NOTE In the SIRI XML schema, the equivalences between the models are mostly encoded by the use of Group tags that are common to all levels. *The properties always appear in the same order within their parent element.*

Table 14 — Inheritance of Timetable Properties

		TIMETABLE	JOURNEY			
Group	Element	DatedTimetable	DatedVehicleJourney	EstimatedJourney	MonitoredVehicleJourney	InterchangeJourney (Feeder/Distributor)
Identity	LineRef	R	I	R	→O	R
	DirectionRef	R	I	R	→O	R
	VehicleJourneyRef	--	R DatedVehicleJourneyCode	R	R FramedVehicleJourneyCode	O FramedVehicleJourneyCode
Change	ExtraJourney	--	O	O	O	--
	Cancellation	--	O	O	O	--
Journey Pattern Info	JourneyPatternRef	O	→O	→O	→O	→O
	VehicleMode	O	→O	→O	→O	→O
	RouteRef	O	→O	→O	→O	→O
	PublishedLineName	O	→O	→O	→O	→O
	DirectionName	O	→O	→O	→O	→O
	ExternalLineRef	O	→O	→O	→O	→O
Service Info	OperatorRef	O	→O	→O	→O	→O
	ProductCategoryRef	O	→O	→O	→O	→O
	ServiceFeatureRef	O	→O	→O	→O	→O
	VehicleFeatureRef	O	→O	→O	→O	→O
Service End point Names	OriginRef	--	--	--	O	O
	OriginName	--	--	--	O	O
	OriginShortName	--	--	--	O	O

		TIMETABLE	JOURNEY			
Group	Element	DatedTimetable	DatedVehicleJourney	EstimatedJourney	MonitoredVehicleJourney	InterchangeJourney (Feeder/ Distributor)
	<i>ViaRef</i>	--	--	--	0	0
	<i>ViaName</i>	--	--	--	0	0
	<i>ViaShortName</i>	--	--	--	0	0
	<i>DestinationRef</i>	--	--	--	0	0
	<i>DestinationName</i>	--	--	--	→0	→0
	<i>DestinationShortName</i>	--	--	--	0	0
Journey Info	<i>VehicleJourneyName</i>	--	0	→0	→0	→0
	<i>JourneyNote</i>	--	0	→0	→0	→0
Dated Info Group	<i>DestinationDisplay</i>	0	→0	--	--	--
	<i>LineNote</i>	0	→0	--	--	--
Service End point Times	<i>HeadwayService</i>	0	→0	→0	→0	→0
	<i>OriginAimedDepartureTime</i>	--	--	--	0	0
	<i>DestinationAimedArrivalTime</i>	--	--	--	0	0
Disruption	<i>SituationRef</i>	--	--	0	0	0
	<i>FacilityChange</i>	--	--	0	0	0
Journey Progress	<i>Monitored</i>	0	→0	→0	0	0
	<i>MonitoringError</i>	--	--	--	0	--
	<i>InCongestion</i>	--	--	--	0	--
	<i>InPanic</i>	--	--	--	0	--
	<i>PredictionInaccurate</i>	--	--	0	→0	--
	<i>DataSource</i>	--	--	--	→0	--
	<i>ConfidenceLevel</i>	--	--	--	0	--
	<i>VehicleLocation</i>	--	--	0	→0	--
	<i>Velocity</i>	--	--	0	→0	--
	<i>Bearing</i>	--	--	--	0	--
	<i>EngineOn</i>	--	--	--	0	--
	<i>ProgressRate</i>	--	--	--	0	--
	<i>Occupancy</i>	--	--	0	0	NumberOfTransfers
	<i>Delay</i>	--	--	--	0	--
<i>ProgressStatus</i>	--	--	--	0	--	
Ops Ref	<i>TrainBlockPart</i>	--	--	--	0	0
	<i>BlockRef</i>	--	0	0	0	0
	<i>CourseOfJourneyRef</i>	--	0	0	0	0
	<i>VehicleRef</i>	--	--	0	0	0

		TIMETABLE	JOURNEY			
Group	Element	DatedTimetable	DatedVehicleJourney	EstimatedJourney	MonitoredVehicleJourney	InterchangeJourney (Feeder/Distributor)
Call	<i>PreviousCalls</i>	--	DatedCall	EstimatedCall	→O	--
	<i>MonitoredCall</i>				→O	R Arrival
	<i>OnwardCalls</i>				→O	--
	<i>IsCompleteStopSequence</i>	--	--	O	O	--

5.18.3 Element equivalences and inheritance – stop call

The properties of the different types of SIRI CALL are shown in Table 15. 'R' indicates a required value. 'O' indicates an optional value. Optional values that are inherited if not specified are indicated by an '→O'. Optional values that will be inherited from the previous call, in preference to the parent journey, are indicated by a 'P'.

NOTE In the SIRI XML schema, the equivalences between the models are encoded by the use of Group tags that are common to all levels. *The properties always appear in the same order within their parent element.*

Table 15 — Inheritance of Call Properties

		Production	Estimated	MonitoredVehicleJourney			TimetabledConnection	EstimatedConnection
<i>Call</i>		DatedCall	EstimatedCall	MonitoredCall	PreviousCall	OnwardCall	TargetFeederArrival	EstimatedFeederArrival
Identity	<i>StopPointRef</i>	R	R	(R)	R	R	(R)	(R)
	<i>VisitNumber</i>	R	O	O	O	O	O	O
	<i>Order</i>	O	O	O	O	O	O	O
	<i>ClearDownRef</i>	--	---	O	--	--	--	O
	<i>StopPointName</i>	O	O	O	O	O	--	O
Change	<i>ExtraCall</i>	--	O	--	--	--	--	--
	<i>Cancellation</i>	--	O	--	--	--	--	--
Real-time	<i>VehicleAtStop</i>	--	--	O	O	--	--	O
	<i>VehicleLocationAtStop</i>	--	--	O	--	--	--	--
	<i>PredictionInaccurate</i>	--	O	--	O	--	--	--
	<i>PassengerLoad</i>	--	O	--	O	--	--	--
	<i>NumberOfTransferPassengers</i>	--	--	--	--	--	--	O
Properties	<i>TimingPoint</i>	O	→O	O	--	--	--	--
	<i>BoardingStretch</i>	O	→O	→O	--	--	--	--
	<i>Requeststop</i>	O	→O	→O	--	--	--	--
	<i>DestinationDisplay</i>	→O, →P	--	O	--	--	--	--
Note	<i>CallNote</i>	O	→O	→O	--	--	--	Reason

		Production	Estimated	MonitoredVehicleJourney			Timetabled Connection	Estimated Connection
<i>Call</i>		Dated Call	Estimated Call	Monitored Call	Previous Call	Onward Call	Target Feeder Arrival	Estimated Feeder Arrival
Disruption	<i>SituationRef</i>	--	O	O	--	--	O	O
	<i>FacilityChange</i>	O	O	O	--	--	O	O
Arrivals	<i>AimedArrivalTime</i>	O	→O	→O	→O	→O	R	R
	<i>ActualArrivalTime</i>	--	--	→O	O	--	--	--
	<i>ExpectedArrivalTime</i>	--	O	→O	--	→O		
	<i>ArrivalPlatformName</i>	O	→O	→O	--	--	--	--
	<i>ArrivalBoardingActivity</i>	O	→O	→O	--	--	--	--
Departures	<i>AimedDepartureTime</i>	O	→O	→O	→O	→O	--	--
	<i>ActualDepartureTime</i>	--	--	→O	O	--	--	--
	<i>ExpectedDepartureTime</i>	--	O	→O	--	→O	--	O
	<i>DeparturePlatformName</i>	O	→O	→O	--	--	--	--
	<i>DepartureBoardingActivity</i>	O	→O	→O	--	--	--	--
Platform Name	<i>AimedHeadwayInterval</i>	O	→O	→O	→O	--	--	--
	<i>ExpectedHeadwayInterval</i>	--	O	→O	--	→O	--	O
Interchange	<i>TargetedInterchange</i>	O Targeted	--	--	--	--	O Arrival	--

5.18.4 Element equivalences and inheritance – service interchange

The properties of the different types of SIRI CALL are shown in Table 16. 'R' indicates a required value. 'O' indicates an optional value. Optional values that are inherited if not specified are indicated by an '→O'. Optional values that will be inherited from the previous call, in preference to the parent journey, are indicated by a 'P'.

Table 16 — Inheritance of Call Properties

		Production	ConnectionMonitoring	
Interchange		TargetedInterchange	FeederArrival	DistributorDeparture
	InterchangeCode	O	O	O
	VehicleJourneyRef	R Distributor		R Feeder
	VehicleJourney	-	R Feeder	R Distributor
Conne ctionLi nk	ConnectionLink	R Distributor	R	R
	ConnectionLinkRef	R	R	R
	InterchangeDuration	O	--	--
	FrequentTravellerDuration	O	--	--
	OccasionalTravellerDuration	O	--	--
	ImpairedAccessDuration	O	--	--
Transf er	StaySeated	O	--	--
	Guaranteed	O	--	--
	Advertised	O	--	--
	MaximumWaitTime	O	--	--

NOTE In the SIRI XML schema, the equivalences between the models are encoded by the use of Group tags that are common to all levels. *The properties always appear in the same order within their parent element.*

5.18.5 Passing times

Transmodel uses specific terms to distinguish between times that a vehicle passes a stop. Different adjectives are used for two purposes:

- To indicate the nature of the event ('Arrival', 'Departure', 'Passing', 'Waiting', etc).
- To indicate the nature of the time ('Timetabled', 'Target', 'Estimated', 'Observed', etc).

Thus: '*Timetabled Passing Time*' is the time from the long term plan. '*Target Passing Time*' is the planned arrival from the latest valid plan (which can include controller actions to cancelled journeys, perform short working, etc). '*Estimated Passing Time*' is the forecast for a monitored vehicle, i.e. the current prediction, and the '*Observed Passing Time*' is used to record the actual time after the event has happened.

NOTE Transmodel uses different adjectives for the times on the entity and on the attributes: for '*Target Passing Time*' the attributes are '*Aimed*'; for '*Estimated Passing Time*' they are '*Expected*' and for '*Observed Passing Time*' they are '*Actual*'. Table 17 summarizes this usage.

Table 17 — Transmodel Passing Time Terminology

	Event Time	Passing Time	Arrival Time	Departure Time
Dated	Timetabled	Timetabled Passing Time	Timetabled Arrival Time	Timetabled Departure Time
	Target	Target Passing Time	Aimed Arrival Time	Aimed Departure Time
Monitored	Estimated	Estimated Passing Time	Expected Arrival Time	Expected Departure Time
	Observed	Actual Passing Time	Actual Arrival Time	Actual Departure Time

Estimated and observed times may only occur in monitored, i.e. real-time contexts.

It is possible for the expected Arrival time to be after the Departure time: this can be used as a technique to express a spread of uncertainty in the data.

6 Notation

6.1 Representation of XML model elements in text

Consistent typographical conventions are used in the SIRI documentation to indicate technically significant information.

- SIRI XML elements are shown in Upper Camel case in bold italics, for example: '***VehicleJourneyRef***'. Element names are based on Transmodel terms wherever possible and shall be followed exactly in implementations.
- Data types are shown in normal italics e.g. '*xsd:boolean*.' Endpoint logical addresses are shown in square brackets, for example [*Subscriber*].
- Code examples are shown in small font.

6.2 Representing relationships in SIRI

Confusion between a definition and a subsequent reference to the definition is a common source of misunderstanding, both in modelling and when using serializations of models as XML schema. This is especially the case when the reference is implemented using an external identifier of the real-world entity that is being represented in the system, as it may not be clear which system, if any, has the responsibility for issuing identifiers and creating the definitions. To mitigate this problem, a systematic naming convention is used in SIRI XML schemas for elements that implement relationships other than of direct containment.

To expatiate: any external entity that needs to be referenced in a computer system shall have an identifier (or compound identifier) that can be uniquely associated with its internal identity within the system. In an XML schema, this 'prime key' will normally be encoded as an attribute or subelement of the main element that defines the entity. This identifier (or in some cases, compound identifier) will then be used to reference the element in the definitions of other entities, that is, to implement the serialization of the relationships those entities have with the referenced entity that need to be modelled. It is extremely helpful for understanding schemas and for avoiding confusion if a consistent naming convention is used to make clear the distinction between definition and reference, and also to indicate which elements are primary identifiers.

The convention used in SIRI follows two simple principles:

- In the defining element, any identifier name (i.e. the 'prime key' attribute or element name) ends in an appropriate noun, such as 'Code' or 'Identifier' (or sometimes 'Number' or 'Timestamp') – for example, ***Operator / OperatorCode***; '0:1'.
- Any references to the entity (i.e. 'foreign keys') use an element name ending in 'Ref'; for example, ***OperatorRef, RegisteringOperatorRef, ParentOperatorRef***. Both identifier instance and reference will typically share a common underlying data type, for example, both ***OperatorCode*** and ***OperatorRef*** will be of type ***OperatorCodeType***.

6.3 Notation for XML model structures of SIRI messages

6.3.1 General

In the SIRI documentation, SIRI XML structures are shown in a tabular form. A separate table is used for each major SIRI request and response message; additional tables are used for the major child elements making up a complex message. To save space, table headings are not repeated on individual tables, but are shown only

in the example. The tables use a consistent set of conventions to describe the XML elements and their constraints.

Table 18 — Example of XML Structure Notation

Organizational Group	Name of Element	Min : Max	Data Type	Description	
	MessageResponse		+Structure	Returns data for a Message Request	
Attributes	srsName	0:1	xsd:string	Default GML coordinate format for any spatial points defined in response by Coordinates parameter.	
Log	ResponseTimestamp	1:1	xsd:dateTime	Time individual response element was created.	
Endpoint	ProducerRef	0:1	→ParticipantCode	Participant reference that identifies producer of data. May be available from context.	
	:::	0:1	AddGroup	MyAddress Group elements. See section 101.0.	
Status	Status	0:1	xsd:boolean	Whether the complete request could be processed successfully or not. Default is true.	
	ErrorCondition	0:1	See below	Description of any error or warning conditions that apply to the overall request.	
			choice	One of the following error codes.	
	a	CapabilityNotSupportedError	-1:1	+Error	Capability not supported.
	b	OtherError		+Error	Error other than a well defined category.
	Description	0:1	→ErrorDescription	Description of Error.	
Payload	ExpectedLifeTime	1:1	PositiveDurationType	How long I expect to live. Time interval.	
	MyWay	0:1	foo bar	Which way I did it. Default is 'foo'.	
	XxxDelivery	0:*	+Structure	See SIRI Part 3 – Functional Service.	

6.3.2 Organizational group label

The first column provides labels describing the categories of element, for example, 'Payload', or 'Topic' groups. This is purely for documentation and in many (but not all) cases corresponds to the name of an XML group used within the schema: in XML, Groups are purely syntactic structures used to organize elements for better clarity and reuse.

6.3.3 Element name

Element names are shown in bold italics in the second column e.g. **VehicleJourneyRef**. The parent element for which the table shows the structure name is shown in the top left of the table.

In many cases elements that are common to a number of messages are described centrally in the section at the end of Part 2. This is indicated by a ':::' for the element name.

Elements comprising a complex type may be nested inline – see also Data Types below. For example in Table 18 **ErrorCondition** has two subelements (i) a choice of error code between **CapabilityNotSupportedError** and **OtherError**, and (ii) a **Description**.

6.3.4 Multiplicity & choice (min:max)

The constraints on the element as to whether it is required or optional, and single or many within its parent element are shown by the third column Multiplicity. Conventional UML '*min:max*' values are used, for example: '*0:1*' indicates a optional, single child; '**1:1**' indicates a required, single child; '*0:**' indicates optional, multiple children, etc. Mandatory multiplicities are emphasized in bold type.

In some cases, one out of a choice of elements may be chosen. This is indicated by a horizontal dash in front of the multiplicity e.g. '**-1:1**' and may also be preceded by a comment. If the multiplicity is the same for all choices, it will be shown once, shared across the different alternative elements.

6.3.5 Data type

Data types are shown in the fourth column in italic font, e.g. *PositiveDurationType*. If the name space of the type is other than the SIRI, the namespace is shown, e.g. '*xsd:dateTime*'.

- A complex type that itself has children defined by a structure is indicated by a type of '+*Structure*'. In SIRI, complex types generally have the same name as the element but with 'Structure' appended to the end. Depending on the size and reusability of the structure, it may be defined in-line by an additional level of nesting or by a separate table elsewhere.
- In the schema complex data types are also used for the data types of elements which implement associations between elements, i.e. which encode the identified foreign key of another entity (see note on representing relationships in SIRI below). For such elements the simple type of the foreign key is generally shown instead, preceded by an arrow. For example for a reference to an **Operator** entity, instead of **OperatorRefStructure**, the data type shown will be →*OperatorCode*.
- Enumerated types are indicated by a list of the allowed values, for example '*lighting | noLighting*'.
- To save space, abbreviations are used for some common types, for example *NLString* for *NaturalLanguageString*, *Error* for *ErrorStructure*.

6.3.6 Description

All elements have a description of their purpose. In some cases this will be a reference to a common definition elsewhere. Any default value for an element is indicated as a comment.

6.4 Notation for diagrams

UML notation is used for Sequence diagrams and for Class Structure diagrams in this document.

Annex A (informative) **Checklist for Implementing SIRI**

A.1 Usage of the DSRC application layer

In order to implement a working SIRI interface between two or more participants, a number of factors need to be agreed. This section provides a check-list of important implementation aspects.

A.2 Legal and commercial Issues

Ownership of real-time content and reference data.

Rights to use content in different operational services.

Rights to use content in different end user services, by web, WAP, SMS, voice, etc.

Rights to sell content to other third parties for exploitation.

Contract length and obligations, Termination.

Service levels.

Allowed load levels.

Promotion of information services.

Public Identifiers of Stops.

A.3 Functional aspects

A.3.1 Main scope

A.3.1.1 General

SIRI Functional Services to be used. SIRI version of Service to be used.

Whether services are publish/subscribe, request/response or both.

Communication Transport layer/protocol (HTTP, SOAP) to be used.

Whether Simple Web Services are needed.

Assess implication for organizational workflows to manage data.

Relate cost/benefits of use of services to organizations' business processes.

A.3.1.2 General Capabilities

Fill the General Capabilities matrix.

- DirectDelivery or FetchedDelivery
- MultipartDespatch support.
- Use of ConfirmDelivery.
- Single/multiple Subscription Filter support.
- Heartbeat support.
- Stop VisitNumber Nature.

A.3.1.3 Service capabilities

For each Service - subset of SIRI functions used (see capability matrix for individual service).

- Fill the individual service capability matrix for functional properties.
- Determine the detail level and individual elements that will be populated.

A.3.2 Service configuration

A.3.2.1 Security & network

IP Authentication or other controls.

Endpoint addresses.

Use of DNS.

A.3.2.2 Service context

Define the operational properties.

Specify the Endpoint addresses.

Define the normal request timeout (before inferring a failure).

A.3.2.3 Access control

Decide if access control is in effect

Define the access permission matrix for each participant.

Define process for specifying and updating permission matrix.

A.3.2.4 Data quality control

Decide responsibility of actors to ensure quality of data

Decide processes to detect, report and correct data errors.

A.3.3 Reference data

A.3.3.1 General

Agree data reference sets and object references.

A.3.3.2 General reference data

Participant references. How participants will be identified.

StopPoint Identifiers. Use of physical or topological Stop Points. Name space for stops (National, Participant, and Participant Pair). Stops covered by System. How stops will be exchanged (use of stop discovery or manual configuration).

ConnectionLink Identifiers. Name space for connections. How connections will be exchanged if there is no Production Timetable service.

Line, Direction (Route) identifiers. Use of discovery or manual configuration.

Classifier attributes:

- **ServiceCategory**: use the recommended list, a subset of the list or an extended list.
- **ProductCategory**: use the recommended list, a subset of the list or an extended list.
- **VehicleFeature**: use the recommended list, a subset of the list or an extended list.

A.3.3.3 Service specific reference data

StopMonitoring point Identifiers. Use of physical or topological Stop Points. Name space for stops (National, Participant, Participant Pair).

VehicleMonitoring Identifiers.

Version Identifiers.

DataFrame for VehicleJourney references.

A.3.4 Error handling

Error Handling (what to do in case of unknown identifier, etc...).

Logging and reporting of errors.

Diagnostic procedures and modes.

A.4 Operational aspects

A.4.1 Systems management

Operational contacts & responsibilities.

Operational contact points for each service.

Service Monitoring procedures.

Planned downtime.

Fault detection and escalation processes.

A.4.2 Provisioning

How data will be set up and maintained for system:

- Use of discovery services or manual configuration.
- Process and frequency of provisioning.
- Access control: configurations of permissions for data.

Annex B **(informative)** **Business Context**

B.1 Purpose of this section

Real-time information has many uses in both the management of public transport services, and the provision of information to passengers. Increasingly, there are circumstances where information needs to be shared between:

- different systems belong to the same organization;
- different organizations.

Systems may be developed by different suppliers, and organizations will normally wish to make independent systems choices. To make this possible in a cost effective way, it is important to have agreed standards for the exchange of real-time information.

However, there are many kinds of real-time information, and some of it is likely to be used only within a single system (perhaps because it is confidential, or because no other system needs it). The SIRI standard only seeks to standardize those information exchanges that are likely to arise regularly in a multi-system or multi-organization context.

To support and inform this, this section presents a series of examples of information exchange. All of them are drawn from real experience of operational contexts in Europe, and on existing system-to-system links or reasonable projections of the current context. This section is structured as follows:

- B.2 describes the general business model of public transport operations, the assets and services being managed and the other business functions that related to them.
- B.3 describes the way in which information is or may be used within and between public transport operations and other business functions, and some of the practical constraints on its use.
- Based on these models, B.4 presents a series of realistic ‘use cases’ for the exchange of real-time information. These use cases are the basis for the services defined in SIRI and collectively form the business justification for this standard.
- B.5 synthesizes the system requirements emerging from these use cases into a generic (logical) system model, which indicates some of the ways in which the SIRI functional services may be used in a typical passenger transport operation.

Annex C provides a limited number of examples of actual deployments of real time information systems, with key data exchange between components indicated using SIRI services terminology, where it would be possible to use such services in lieu of existing protocols.

This section does not seek to be comprehensive or definitive: it only provides an illustration of some of the typical context for SIRI usage. There are many other business scenarios currently in use and many more possible. Not all of them will comply simply with the business and systems models presented here. However, they may still make use of relevant SIRI-compliant information exchanges.

The services defined by SIRI are subject to continual review. Where a need is identified for additional services, the intention is to extend the business justification in this section to explain why, and to add a description (if practical) of the relevant service to the normative sections of this standard.

B.2 Business model

B.2.1 Passenger transport operations

B.2.1.1 General

The scope of SIRI is the management, operation and use of passenger transport operations. The key business elements of this context are as follows:

- Mobile vehicles;
- Infrastructure (roads, rails, etc) for the vehicles to run on;
- Passengers which use the vehicles;
- Money, paid by passengers in exchange for the use of the vehicle;
- Schedules which are updated;
- Control centres;
- Journey planners, used by passengers;

B.2.1.2 Mobile vehicles

The essential component of passenger transport is the vehicle. The vehicle moves around a specific route. At specific points on the route, passengers will get onto the vehicle and, at their destination, get off the vehicle.

So that passengers understand the route of the vehicle it will normally be associated with a logical service, which will normally be numbered. The specific pattern of operation may vary from day to day or by time of day.

The vehicle may or may not have a human driver. It may carry individual passengers or groups of passengers making the same journey, and the route may or may not be known in advance. However the context that SIRI primarily applies to is the context of planned services: the vehicle traverses a known route, allowing any passengers to get on and get off at the stopping points along the route.

In this context it is important for the passengers to know about the planned and actual movement of the vehicle.

Finally, vehicles differ in their characteristics: specifically, some are more accessible for disabled passengers than others. Passengers may need to know such features in advance.

B.2.1.3 Infrastructure

Vehicles will travel on an infrastructure, which may be subject to independent management. SIRI is primarily intended for services that use road or rail, although air lanes and waterways/sea lanes play a similar role for some passenger transport.

Historically, the infrastructure has been relatively passive on roads. Thus, buses shall obey traffic signals, but provide no information to the road management. However, this is no longer the case, and in many cities traffic signals will be informed of the imminent arrival of a bus in order to facilitate its transit through a junction in preference to private cars. Also, information about the running of buses gives road managers valuable information about the location and development of congestion and other traffic parameters, and is increasingly sought.

Rail-based vehicles are subject to signals in a similar way, and there is information exchanged between the vehicle and the infrastructure to set signals – for example, to prevent accidents. For SIRI, it is relevant that the rails and the trains using them may be under the control of different organizations.

B.2.1.4 Passengers

Passengers aim to travel on passenger transport. They may need to find out about trip options, then to plan a trip and buy one or more tickets, and then be informed about the operation of the service on their way to the stop/station and during the course of their trip.

Where fixed routing is used, passengers may need to use more than one ride. They need to be informed about their whole trip, i.e. all of the rides they intend to use and the points at which they move from one ride to another.

B.2.1.5 Money

Passengers will almost always pay towards the cost of their travel, sometimes in advance but sometimes on the journey or after completion of the journey.

The options for this are complex, and SIRI does not consider further the issues related to payment, which are the subject of other standardization initiatives.

B.2.1.6 Schedules

SIRI focuses on the case where a vehicle has a planned stopping pattern. Usually this will be to a fixed timetable, determined in advance and made public; sometimes it will be based on headway, taking into account current running conditions and possibly current passenger demand.

In either case, the planned timing for a vehicle movement is subject to change, both prior to setting out and once *en route*. Passengers need to know about this, and may also need to know how this affects a connecting service.

B.2.1.7 Control centres

A control centre is a fixed establishment where a passenger transport operator can:

- monitor the current running of his services;
- monitor other current factors, such as congestion on the network, security incidents, the running of connecting services (which may be operated by other operators) or passenger numbers;
- take decisions about how to change current operations;
- advise other organizations of relevant information;
- control the movement of his vehicles, either via communication with the driver or directly.

B.2.1.8 Journey planners

A journey planner is a specialized service that allows passengers to determine, either prior to travel or during travel, the best route for them to take personally. The most sophisticated forms of journey planner take due account of current and projected running of all available services, which may include service run by several operators.

Journey planning was traditionally undertaken through passengers asking operator staff for advice, but is now increasingly provided by third party organizations using software tools. Journey planners may be available

over the web, using passengers' mobile phones or PDAs, or using kiosks and terminals provided by an operator or by a municipal authority.

B.2.2 Organizations

The functions provided in the business context described above will be undertaken by a variety of individuals and organizations, with different needs and constraints.

- Passengers want an effective and efficient service. They also want to know how long their trip will take, where they have to be to make use of it, and what else they have to do. They are concerned with reliability, cost, accessibility, comfort and security.
- Passenger transport operators want their vehicles to pick up as many passengers as possible. They want to know where their vehicles are, how well they are running and how well they are likely to run in the near future. For commercial (and sometimes legal) reasons, they may not want others to know how their services are running – although they do want to advise their potential passengers.
- Infrastructure (road or rail) managers want to ensure that their network is used effectively and efficiently. They value advice from anyone who has information about network conditions, and are usually happy to provide synthesized information to anyone. They sometimes provide specific services, such as signal priority for passenger transport vehicles.
- Journey planners need information from all of the above, and use specialist software to match requirements from passengers against the offerings from transport operators – mindful of network conditions.
- Regulators, who set rules for the operation of passenger transport. Usually they will not want access to real-time information, but will want consolidated reports based on data obtained from the actual running of services.

Each type of organization will typically act both as a data publisher and as a data receiver. Most have both roles at different parts of the business process.

B.3 Use of information in public transport

B.3.1 Overview

There are many types of data involved in RTI systems, including but not limited to the following information on bus stops, networks, services, traffic management and passenger management. This information will need to be exchanged in a timely, efficient and secure way to deliver an effective RTI service.

Ownership of different types of data, and responsibility for its management, will normally rest with different organizations. This may vary from scheme to scheme and the following is only intended to serve as an illustration rather than a definitive statement.

B.3.2 Data ownership

B.3.2.1 General

For the purposes of this standard, relevant data is categorized into six distinct areas of data 'ownership'. It is not necessary for any specific implementation to categorize data in this way to make use of the SIRI standard and these categories may not be associated with formal legal ownership.

B.3.2.2 Transport infrastructure

Roads and rail infrastructure; typically described using nodes and links, together with other details of the physical geometry of the transport network.

Additional information may include information about signal priority opportunities, other transport associated infrastructure, such as overhead wires.

The transport infrastructure may be focused only on motorized transport (car, buses, trams, trains), but can also include information about cycling and walking. It may include turning restrictions at junctions, modal restrictions (taxi only, bus only) and time constraints (closure on market days at certain times).

Planned changes to this network, both permanent and temporary that are known about in advance should be included.

In practice this data may be managed by a number of different organizations, including the urban traffic management system, trunk road management, rail companies and surveying organizations (such as the Ordnance Survey in the UK).

- Source: Ordnance Survey, Urban Traffic Management, Highways Agency, and Rail Authorities.
- Management: Local Authority, Rail Authority.
- Users: Traffic Management, Car drivers, PT Schedulers, PT Management.

The detailed exchange of Transport Infrastructure data is beyond the scope of SIRI.

B.3.2.3 PT infrastructure

Information related to PT Infrastructure covered by SIRI are:

- Locations and names of Stop Points, Stop Areas,
- Connection Links,
- possibilities to transfer between Stop Points within interchanges,
- details of how to access the Stop Points when walking, cycling and driving from the Transport Infrastructure.

Data may cover one or more modes (rail, metro, tram, ferry, air and bus). It may cover facilities at stop and interchanges: displays, seats, car parking, cycle parking. It may provide accessibility information for various disability groups: Wheel chair users, sight impaired, etc.

Some Stop Points will be simple point locations; Stop Areas may be large, complex interchanges, covering multiple modes, with a number of hierarchical levels such as a major airport with multiple terminals, and rail, metro, coach and bus services.

Even where the data is available nationally, it is likely to be appropriate for the information to be gathered and maintained at a local level and for some transport modes (rail metro, ferry, air) to maintain the data for their own networks.

The information should cover planned changes to the offered facilities and services over time (both permanent and temporary) that can be identified in advance. These should include temporary and permanent closure, physical relocation on stop, changes to accessibility, changes to interchange times or changes to available facilities.

- Source: Central (UK), regional traffic Authority and Rail (D).
- Management: Regionally managed but centrally collated (UK).
- Users: PT Schedulers, PT Managers, and Journey Planners.

The detailed exchange of information about Stops and Interchanges is beyond the scope of SIRI. However an agreed referencing system for Stop Points will be required.

B.3.2.4 PTV schedules

Schedules describe the planned operation of transport services, identifying which Vehicle Journeys will operate, on which routes, and on which Operational Dates and on what Day Types. In addition Vehicle Schedules may contain details of the vehicle working patterns as Blocks.

Schedules will often be applicable for a number of months and will be available well in advance. Adjustments to these schedules will often be made as the operational day approaches (sometimes with daily updates) to accommodate changes to the Transport Infrastructure, the PT Infrastructure and other factors.

These schedules will often reference the Transport Infrastructure and PT Infrastructure described above using a Route description.

- Source: Transport Operator or Local Authority
- Management: Transport Operator or Local Authority
- Users: Transport Operator, Local Authority, Information Disseminators, and Journey Planners

B.3.2.5 Integrated PT plan

The Integrated PT Plan brings together PTV schedules for one or more transport operators (possibly for multiple modes) and combines this with relevant information from the Transport Infrastructure and PT Infrastructure.

The integration of PT information is frequently managed on a regional basis.

A new plan will often be produced for each operation day taking into account any changes to the transport infrastructure, PT Infrastructure and PT Schedules and will be made available a few hours of days in advance.

This integration may be performed by a regional transport authority or by other organizations that required an integrated data source.

- Source: Local Authority, Public Transport Operator
- Management: Local Authority
- Users: Fleet Management, Travelling Public, Journey Planners, and Information Dissemination

B.3.2.6 Real-Time PT status

During an Operational Day, details of the location of vehicles, the operational status of Lines and the allocation of drivers and vehicles to operate the services will be maintained. Forecasts for the real-time arrivals and departures of services will be maintained, together with details of cancellations, detours and additional services.

Each Transport Operator may operate their own PT Management System; alternatively multiple Transport Operators may share a single management system,

- Source: Public Transport Operator or Local Authority
- Management: Public Transport Operator
- Users: travelling public, PT management staff, Traffic Management Centre

B.3.2.7 Real-Time transport infrastructure status

During the Operational Day the Transport Infrastructure (roads, track etc) will be monitored and managed to limit the disruptions caused by disturbances to the transport infrastructure.

Information will be maintained on the status and performance of sections of the infrastructure, and details of any Situations and associated closures and detours.

- Source: Urban Traffic Management Centre, Highway Management.
- Management: Urban Traffic Management Centre.

B.3.3 Temporal considerations

B.3.3.1 General

On any particular day various actors will be working with data on different time horizons. Some will be considering what is happening right now and over the next hour, some will be looking ahead one or two days, others may be planning well in the future or analysing what happened yesterday and further in the past.

B.3.3.2 Preparation of a new timetable

New schedules may be planned well in advance and new schedules may be introduced a few times a year. Schedules are currently published in a variety of formats often agreed at a national level.

B.3.3.3 Adjustments to a timetable

Following publication of a Schedule it may become necessary to make adjustments to the schedule for any number of reasons that were unforeseen at the time of publication. These adjustments may be made to the currently active schedule or to a schedule that has been registered but has yet to come into effect. These adjustments are currently published in a variety of formats, often agreed at a national level.

B.3.3.4 Production timetable

As each Operational Day approaches, detailed planning will take place, detailing the operational activities for the day and vehicles and drivers that will be assigned to support these activities. The SIRI Production Timetable can provide information about the intended operation for a specified operational day and is published one or more days in advance of the Operational Day in question.

B.3.3.5 Estimated timetable

During the course of a day the operation of the service may deviate from the intended pattern. If the deviation is minor (a vehicle is delayed by a few minutes) then no additional actions will be taken. If however the deviation is larger, then operation staff may make Control Actions to minimize the disruption caused by the disturbance to the transport system, for example, cancelling journeys, adding new Journeys, re-routing vehicles. The SIRI Estimated Timetable Service can be used to provide real-time information on these changes.

B.3.3.6 Reporting and analysis

On a regular basis, the operation of the transport service will be reviewed possibly leading to changes to future schedules and other interventions to improve the future performance.

B.3.4 Information security

In exchanging information, both publishers and receivers of information need to be assured of the security of the exchange.

Publishers need to be assured, where the information they provide is confidential, that:

- the organization receiving their information is the organization that it claims to be;
- it will not be accessible to unauthorized receivers;
- other information is not unexpectedly released.

Receivers need to be assured that:

- the information they are receiving is from organization that it claims to be;
- the information will be available when they need it;
- the information has not been corrupted, accidentally or deliberately, in transit;
- their own information is not unexpectedly released.

Confidential information includes:

- information with commercial value;
- information with personal or privacy implications.

Generally all parties will be happy to discuss their security needs with each other, and agree a common approach to implementation of security, through a bilateral or multilateral security policy.

B.3.5 Regulatory issues

Different transport environments will have different regulatory regimes, which may change over time. The regulation may have an impact on what information exchange is possible or desirable. Regulation may also be hard to reconcile, and leave implementers of systems few options. Specific regulations that affect SIRI users will include:

- General business regulation – for example on fair trading and prevention of anti-competitive cartels.
- Informatics regulation – for example data protection and freedom of information.
- Transport specific regulation – for example on reporting performance against punctuality targets or response to customer complaints.

B.4 Use Cases for this standard

B.4.1 Introduction

There are many potential ways for passenger transport operations centres to interact. This standard is based on a specific set of 'use cases', described below:

- Provision of Service Information to Passengers (B.4.2)
- Provision of Information to Journey Planners (B.4.3)
- Facilitating Connections for Passengers (B.4.4)
- Fleet and Network Management (B.4.5)
- General Business Communication (B.4.6)

These use cases, which are non-normative but are regarded as typical, are used to develop a normative set of models for communications in Part 2 and data structures in Part 3 of the SIRI document set.

B.4.2 Use case: provision of service information to passengers

B.4.2.1 User requirements

In planning or making a journey a passenger will benefit from the ability to identify the services expected at a particular stop. This may be through a sign at the stop, for passengers already there, or may be through a remote information delivery system (SMS, Internet, etc), for passengers planning a journey in the short term.

The services operating at a particular stop may be controlled by a variety of control centres. Therefore control centres need to provide current running information of all vehicles relevant to a particular stop to any organization responsible for setting at-stop signs or providing remote information.

Users need a display or other indication which shows the progress of the vehicle, or vehicles, in which they planning to travel. They may need information on alternative options, for instance if their chosen service is seriously delayed.

Figure B.1 shows two generic scenarios for the information passing from bus to passenger.

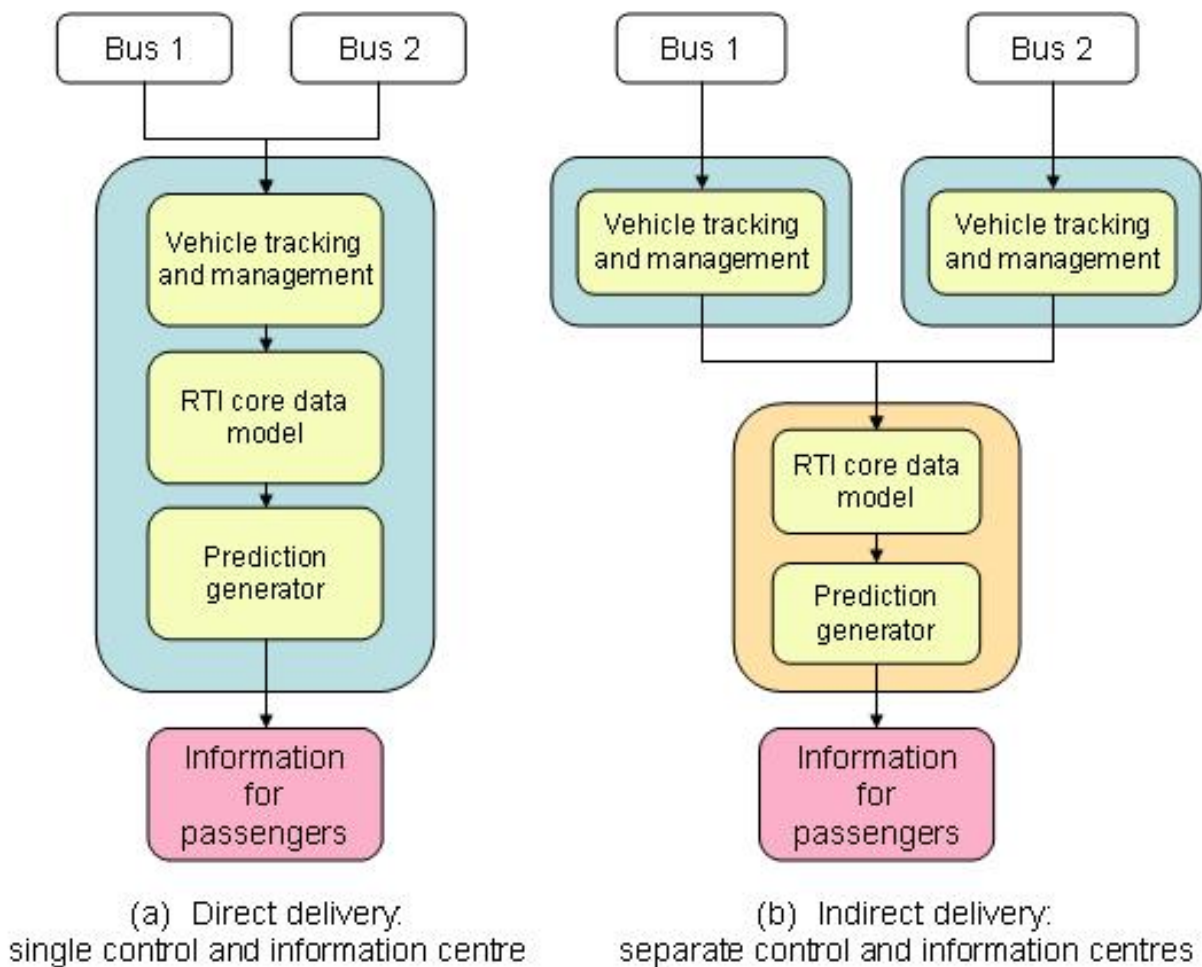

Figure B.1 — Two models of passenger information provision

Information for passengers ultimately comes from vehicles notifying control centres of their position and movements. This may be direct, as when an operator's control centre itself sends information to the stop sign or the passenger's web browser. Alternatively, it may be indirect, for instance when several operators send information on their own services to a local authority, which then collates the information for presentation.

In the first case, the operator may still have separate systems for tracking vehicles and preparing information for passengers. In the second case, the operators may choose to make their own predictions or, as shown in the diagram, the consolidator may have better access to the other information (such as congestion information) that makes prediction possible.

The information presented to passengers will generally be for services to a single stop. The information presented from collectors to consolidators will generally be a bulk transfer of all relevant information (for instance – all services in a particular operating area).

B.4.2.2 Service requirements – SIRI Stop Monitoring (SM)

The SIRI "Stop Monitoring" service enables the provision of information on services due to call at a stop, either on a physical stop display, or on a remote device such as a mobile phone or web browser. Data exchange is location specific, i.e. it involves the transfer of arrival and departure tables for timing points that have been mutually defined in advance.

The Stop Monitoring service should provide all the current relevant information from one AVMS relating to one particular stop.

B.4.2.3 Service requirements – SIRI Vehicle Monitoring (VM)

The SIRI "Vehicle Monitoring" service enables the provision of information on the current location and status of a set of vehicles.

The Vehicle Monitoring service should provide all the current relevant information from one AVMS relating to all vehicles fulfilling a set of selection criteria.

B.4.3 Use case: journey planning

B.4.3.1 User requirements

A schedule information system shall be able to respond to customer enquiries concerning vehicle journey planning:

- Long-term: "How do I plan my journey to X next week?"
- Mid-term: "What's the best way to the opera tonight?"
- Short-term: "When does the next bus leave from the stop opposite?"

In general, only the published schedules that are valid for longer periods are made available to the schedule information system for all request periods. For the purpose of long-term journey planning, this data represents the most up-to-date and with that the best foundation. However, neither the day-to-day changes in the journey planning nor the current events within the operation can be included in the schedule information on the basis of this data.

The quality of information provided in response to mid and short-term enquiries can be significantly improved when using more up-to-date data. This may include daily planning data, such as the subsequent dispatch of additional vehicle journeys or cancellations, or actual real-time information, such as current delays, vehicle journey failure or short-term disturbances.

Users need data to be available not just for individual stops or connection links but for the largest possible number or ideally all lines and stops.

B.4.3.2 Service requirements – SIRI Production Timetable (PT)

The SIRI "Production Timetable" service enables the provision of information on the planned progress of vehicles operating a specific service, identified by the vehicle time of arrival and departure at specific stops on a planned route for a particular Operational Day.

The Production Timetable service should provide all the current relevant information from one AVMS relating to one service fulfilling a set of selection criteria.

The exchange of published timetables is not part of the SIRI standard as there are likely to be more effective and efficient way of exchanging these other than over a real-time link.

B.4.3.3 Service requirements – SIRI Estimated Timetable (ET)

The SIRI "Estimated Timetable" service enables the provision of information on the actual progress of Vehicle Journeys operating a specific service Lines, detailing expected arrival and departure times at specific stops on a planned route. There will be recorded data for stops which have been passed, and predicted data for stops not yet passed. In addition the Estimated Timetable service allows Vehicle Journeys to be cancelled, added or changed.

The Estimated Timetable service should provide all the current relevant information from one AVMS relating to one service fulfilling a set of selection criteria.

B.4.4 Use case: facilitating connections for passengers

B.4.4.1 User requirements

When passengers are making a trip formed of several rides, they will require up to date information for each connection to inform them of all the possibilities for the subsequent ride. This is especially important where one of the vehicle journeys is delayed and provides passengers with confidence to do multi-leg journeys.

Passenger journeys frequently involve more than one public transport service, and require a connection from one service to another. The effectiveness of the connection represents a significant comfort or acceptance factor. There is a need to guarantee the least possible waiting time for each individual vehicle journey relationship.

Partly this is addressed by good schedule planning, but as real services may vary from schedule this is not always enough. Passengers want to be assured that their connecting service will be, as far as possible, available for them when they arrive at the connection link, even if their first service is running late.

Connection planning should take into account the journey time between the arrival stop and the new departure stop, which may be some distance apart.

In some circumstances it may be appropriate to provide 'connection protection' – in other words, a guarantee to passengers that even if their current service (the "feeder") is running late, the service they wish to change to (the "distributor") will wait for them.

In either case the task is complicated if the two services are operated by two different operators. In this circumstance, the two operators will need to establish a way of identifying which connections will be guaranteed. At present this is normally done by prior agreement and not by automated negotiation, and SIRI does not address this process.

B.4.4.2 Service requirements – SIRI Connection Timetable (CT)

The SIRI "Connection Timetable" service may be used to provide information about the scheduled arrivals of a feeder vehicle to the operator of a connecting distributor service. The distributor operator can then plan how to guarantee the connection, either with the expected vehicle or a different vehicle.

The Connection Timetable service should provide the necessary information from one AVMS relating to one service at one connection link/area.

B.4.4.3 Service requirements – SIRI Connection Monitoring (CM)

The SIRI "Connection Monitoring" service is used to provide information about the expected arrival of a feeder vehicle to the operator of a connecting distributor service. The distributor operator can then manage the service to guarantee the connection, based on actual vehicle running.

The Connection Monitoring service can be used both to monitor journeys whose schedules have been previously exchanged using the Connection Timetable service, and to monitor journeys without previous exchange of data.

B.4.5 Use case: fleet and network management

B.4.5.1 User requirements

Operators in control centres need to monitor the running of vehicles in their control area. This includes being able to identify visually on a screen the location and movement of vehicles, and to find out more about individual vehicles if necessary.

In some cases – for example, in the case of a central data consolidator that takes input from several operators, as in Figure B.1(b) – an operator will need to view the activities and locations of vehicles which are being tracked by the AVMS of one or more external organizations.

To ensure clear presentation, operators will need to inspect the activities of particular groups of vehicles (e.g. individual regions or services) without clutter from other information.

B.4.5.2 Service requirements – SIRI Vehicle Monitoring (VM)

The SIRI "Vehicle Monitoring" service enables the provision of information on the current location and status of a set of vehicles.

The Vehicle Monitoring service should provide all the current relevant information from one AVMS relating to all vehicles fulfilling a set of selection criteria.

B.4.6 Use case: general business communications

B.4.6.1 User requirements

There is a need for operators and others in participating control centres to exchange general operational information.

In some circumstances, this might be human readable information such as might be sent by fax or email – it may prove operationally simpler to pass these messages through the system-to-system connection. In other circumstances, it might be appropriate to transfer data files in some other agreed format.

SIRI does not specify how the payload data structure should be determined for general messages – this will normally be agreed by some other mechanism.

B.4.6.2 Service requirements – SIRI General Message (GM)

The SIRI "General Message" service is used to exchange informative messages between identified individuals in free or an arbitrary structured format.

The General Message service should enable messages to be sent and to be revoked. Messages should be assigned validity periods in addition to the actual content.

B.5 SIRI System Model

B.5.1 Modularization

This system model is an abstract generic model of the major areas impacting on the provision of public transport and the management functions that are required to provide a high quality public transport service for which accurate information is available.

Across Europe the management of these functions may be organized in different ways and in some cases the functions may not be differentiated from each other (for example the Stops and Interchanges description may

be incorporated into the Transport Infrastructure module or within the PT Schedules module). The figure below shows a generic (logical) systems architecture that encompasses some of the main interfaces.

B.5.2 PT Infrastructure Management Module

Manages information about stops and interchanges as described in the data sources section above. This may be managed on a national or on a regional basis, or by each transport operator independently. Where this information is maintained locally a common referencing system will need to be agreed.

B.5.3 Transport Infrastructure Management Module

Manages information about the transport Infrastructure (roads and tracks), typically described as links and nodes and related to the underlying geography.

This may be managed by one national source, but is more likely to be shared between a number of agencies, for example the Ordnance Survey in the UK for the base road network, the highways agency for the trunk road network and urban traffic management centres for the smaller road in urban areas.

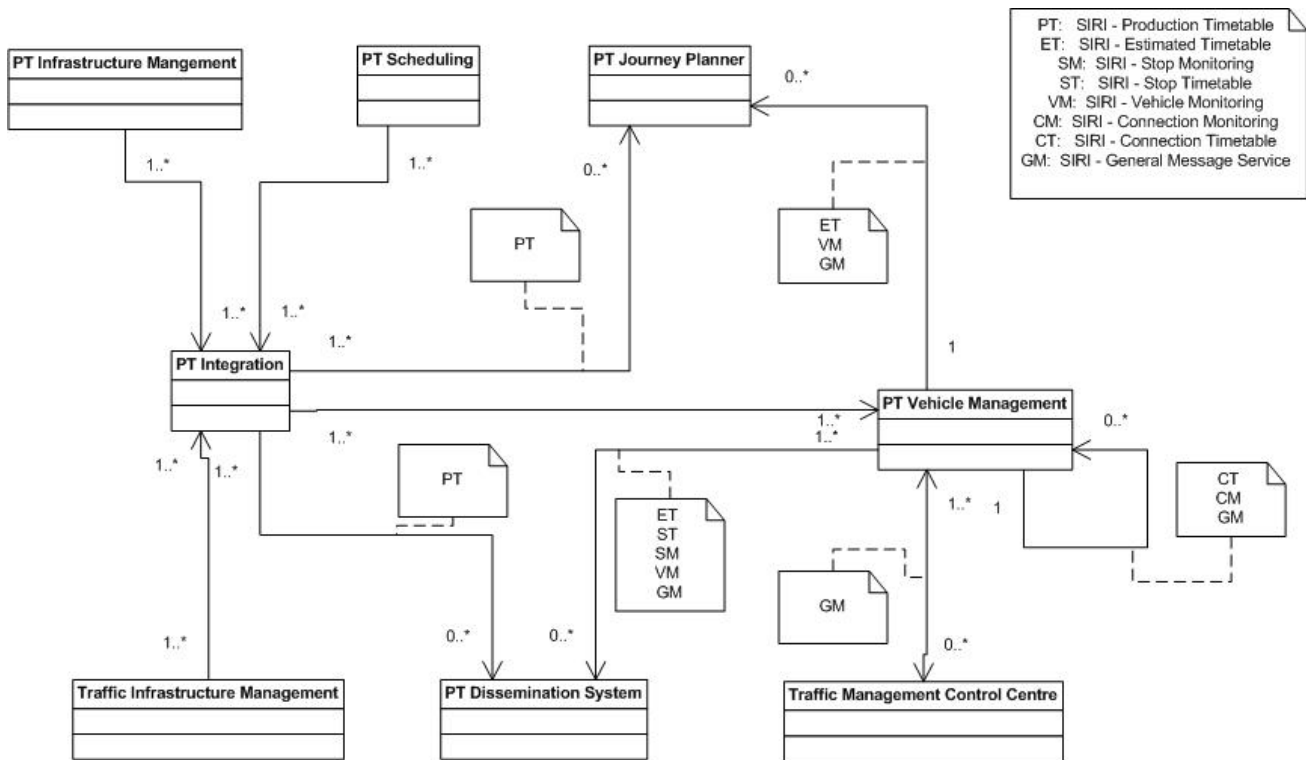

Figure B.2 — Generic model of PT operations, showing exchange points for RTI and the SIRI services available for these roles

B.5.4 PT Scheduling Module

The scheduling of public transport is either prepared by a transport operator or by a transport authority. Typically a single region will have multiple transport operators and transport modes, sometimes with different schedule update cycles. Each PT schedule will be updated to cater for adjustments to the transport infrastructure and PT infrastructure, as well as for other reasons.

B.5.5 PT Integration Module

A PT integration module brings together information from multiple Transport Operators, often for all transport with a whole region, to provide information across multiple operators and modes for various purposes, including Journey Planning and Information Dissemination.

The PT Integration may be managed by the Transport Authority, or be handled in an ad-hoc manner by service providers, such as Journey planners and Information Dissemination.

A Production Timetable Plan may be prepared for each Operational Day, detailing the required information for all activities for the day.

The PT Integration Module may make available the following SIRI Functional Service:

- Production Timetable (PT)

B.5.6 Traffic Management Control Centre

A traffic management control centre provides moment-by-moment management of the Transport Infrastructure, reacting to incidents, breakdowns and other disturbances to the network. A PT Vehicle Management module may interact with multiple Traffic Management Control Centres, and each Traffic Management Control Centre may interact with multiple PT Vehicle Management Modules.

This monitoring may use electronic sensors, CCTV cameras, floating vehicles and information from the public transport fleet.

Management techniques may include tactical use of the traffic signals, the deployment of on-street personnel to facilitate the removal of obstructions, the sign of detours and the provision of advisory information to the public and the other road users, such as the PT Transport Operator. A prognosis may be available indicating the duration of the disruption.

The management of the transport infrastructure is often split between local roads and national strategic roads, and between road-based transport, and other modes (rail, air, ferry).

The Transport Infrastructure Management Module may use the following SIRI Functional Service:

- SIRI General Message Service (GM)

The Transport Infrastructure Management Module may make available the following SIRI Functional Services:

- SIRI General Message Service (GM)
- SIRI Situation Exchange Service (SX) – to exchange incident and road performance data
- SIRI Facility Monitoring Service (FM)

B.5.7 PT Operational Control

Provides real-time management for one or more Transport Operators allowing operators to adjust operations to accommodate operational disturbances and provide the public with the latest operational information.

In some instances each Transport Operator will manage their own management system, in other cases multiple transport operators in a region share a single system.

PT Vehicle Management systems may also share information with other PT Vehicle Management Systems to assist in the provision of connected services.

The PT Vehicle Management Module may use the following services:

- Production Timetable (PT)
- Connection Monitoring (CM)
- Connection Timetable (CT)
- General Message Service (GM)
- Situation Exchange Service (SX)
- Facility Monitoring Service (FM)

It may make available the following SIRI Functional Services:

- Stop Monitoring (SM)
- Vehicle Monitoring (VM)
- Estimated Timetable (ET)
- Connection Monitoring (CM)
- Connection Timetable (CT)
- General Message Service (GM)
- Situation Exchange Service (SX)
- Facility Monitoring Service (FM)

B.5.8 PT Journey Planner

A PT journey planner provides Journey information services for one or more Transport Operators and one or more transport modes. Typically this will provide information for longer term enquiries using the basic scheduled information, enquiries a few days in advance using the schedules adjusted with known planned changes, and a few minutes in advance where real-time information may also be used.

The Journey Planner may use the following SIRI Functional Services:

- Production Timetable (PT)
- Estimated Timetable (ET)
- Vehicle Monitoring (VM)
- General Message Service (GM)
- Situation Exchange Service (SX)
- Facility Monitoring Service (FM)

B.5.9 Passenger Information

Passenger Information provides information to the public when planning trips using public transport, often using real time displays at Stop Points or personal electronic devices including mobile phones, web browsers.

The Passenger Information module will manage the communication, presentation and navigation of data to particular devices.

The Passenger Information system may use the following SIRI Functional Services:

- Production Timetable (PT)
- Estimated Timetable (ET)
- Stop Monitoring (SM)
- Vehicle Monitoring (VM)
- General Message Service (GM)
- Situation Exchange Service (SX)
- Facility Monitoring Service (FM)

Annex C (informative) **Background and Mapping of Some Current Implementations to SIRI**

C.1 Introduction

This section illustrates a number of deployment scenarios, together with the parts of the SIRI standard which may be applied instead of the national standards or proprietary interfaces currently deployed. Future additions to the SIRI standard are anticipated to support additional deployment models not considered here, or to extend the interoperability of some of the models below.

In the following diagrams, arrows with solid lines and SIRI Functional Services listed represent functions catered for by SIRI; arrows with dotted lines and SIRI services listed represent functions partly catered for by SIRI currently; and arrows with dotted lines represent non-SIRI protocols.

The deployment figures contain functional blocks on a high level and do not show the complexity within these functional blocks. For instance, the Passenger Information functional block can contain information provision to a variety of passenger information systems through many different types of media, e.g. journey planners, display system, and personal information systems like SMS/WAP services. The functional blocks are further described in each example.

C.2 SIRI origins

C.2.1 VDV453/VDV454

The '*Integration Interface for Automatic Vehicle Management Systems*' - known as VDV 453/454 has been developed with support of the German Federal Ministry for Traffic, Construction and Housing, building on the experience since 1999 of both German Public Transport Organisations and Suppliers. The 'Integration Interface' has been a standard feature of AVMS-systems in Germany since the first publication as VDV 453 standard in 2001. The current version 2.1 of VDV 453 has the following Services:

- Connection Protection.
- Dynamic Passenger Information.
- Visualization.
- General Message Service.

Since 2003 VDV453 has been complemented by VDV 454 Version 1.0, which describes the 'Schedule Information' service for the exchange of real time schedule data from an AVMS to a trip planning system.

VDV453 and VDV454 are managed by the Verband Deutscher Verkehrsunternehmen (VDV).

C.2.2 TRIDENT

TRIDENT is a 5th Framework Programme EU project that focuses on the exchange and sharing of multi-modal Travel and Traffic information. As with similar past projects aimed at individual single modes, the project is intended to encourage the development of telematic networks and to enable a more rapid diffusion of ITS services. The TRIDENT approach provides new data exchange mechanisms which support multi-modal, state-of-the-art technologies and more open architectures and networks.

TRIDENT is targeted at Authorities, Operators and Service Providers, that is public bodies or private companies that need to exchange large amounts of travel and traffic data, either for internal management purposes, or in order to provide information or services to third bodies. It allows a clear separation of the different roles of providers of *data*, *content* and *services* in the information chain to convey transportation related information services to end users. TRIDENT enables the publication of, and access to, a wide variety of different information using homogeneous functions and techniques.

The following families of information can be exchanged within the current version 2.0 of the TRIDENT specifications:

- Road traffic data (traffic measurements).
- Situations and events, in the road traffic and public transport domain.
- Trip times.
- Itineraries.
- Public transport network descriptions.
- Public transport static timetables.
- Public transport status.

The TRIDENT Logical Data Model is described as a set of UML diagrams. The structure of the Logical Data Model is the result of a coherent union of existing data models in the Road Traffic domain (mainly DATEX 1.2) and in Public Transport domain (TRANSMODEL 5.1). The W3C XSD language (XML Schema Definition) is used to define the XML data exchange.

TRIDENT is currently used by a number of major projects and organizations to exchange real-time data. Implementers include: RATP (France), AMIVIF (AMIVIF activity has been integrated into STIF activity since January 1st, 2008) for Public Transport data exchange in the Ile-de-France region (France), CHOUETTE for Public Transport data capture, storage and exchange (France), RTIG in UK (see the RTIG description below), etc.

C.2.3 RTIG-XML

RTIG-XML v1.0 was developed in 2002 by the UK Real-time Interest Group, with contributions from RTIG members including suppliers and local transport authorities. The scope of RTIG-XML v1.0 is limited to server-to-server exchange of:

- Scheduled and real-time stop departure data.
- Real-time vehicle movement data.

The v1.0 schema assumes known servers using a common stop referencing system based on version 1.0 of the UK NaPTAN standard. RTIG-XML supports both publish/subscribe and request/response patterns of exchange, using direct one-step delivery for both. RTIG-XML is organized into a core set of features required for basic compliance and a number of optional feature sets representing additional capabilities. The v1.0 schemas are based on Transmodel and formally reference the TRIDENT 2.0 XSD schema, also based on Transmodel, for data types. W3C xsd format is used, with documents usually being exchanged using http POST.

RTIG now operates through a publicly-owned company which holds the IPR on RTIG-XML. A revised version of RTIG-XML standard is in an initial planning stage; it is intended that this should be based on SIRI.

C.2.4 CEN TC278 WG3 SG7

During 2004-2005, CEN convened a new subgroup of TC278 WG3 to consider whether there was merit in aligning and merging the national specifications with the results of the European TRIDENT project. A number of preparatory meetings indicated that there was little conflict among these and that harmonization at European level would be beneficial to all.

SG7 was organized by VDV (D) with editorship provided by RTIG (UK). Other participants were as follows:

- Mobile Radio Consultation, CZ
- BLIC GmbH, D
- Hamburger Berater Team GmbH, D
- Init, D
- Mentz Datenverarbeitung GmbH, D
- PSI, D
- Siemens Transit Telematic Systems AG, D
- HUR, DK
- Dryade, F
- PDG, F
- RATP, F
- Trafikanten Oslo og Akershus, NO
- Columna, SE
- HOGIA, SE
- VTT, SF
- Acis, UK
- Centaur Consulting Limited, UK
- Kizoom, UK
- West Yorkshire PTE, UK

The table below lists the different SIRI Functional Services and their RTIG and VDV equivalents. In the following deployment examples the SIRI names have been used to indicate the different services currently existing or planned in each situation.

Table C.1 — List of SIRI Functional Services with RTIG and VDV equivalent services currently deployed

SIRI Functional Service	RTIG equivalent	VDV equivalent
Production Timetable Service (PT)	None	VDV 454 Ref-SIS
Estimated Timetable Service (ET)	None	VDV 454 SIS
Stop Monitoring Service (SM)	StopStatusRealTime	VDV 453 Dynamic Passenger Information
Vehicle Monitoring Service (VM)	VehicleStatusRealTime	VDV 453 Visualisation
Connection Monitoring Service (CM)	None	VDV 453 Connection Protection
Connection Timetable Service (CT)	None	VDV 453 REF - CP
General Message Service (GM)	None	VDV 453 General Message Service

C.3 Deployment Example – Berlin

This contains a central information dissemination system linked to multiple AVMS systems and also to systems from other modes such as air. The information dissemination system provides information to several passenger information systems. Two transport providers each with a number of Local Vehicles are fitted with equipment enabling them to report their position and related information over a communications network to their own AVMS Server. Operational Control centres are connected locally to each AVMS. Information is currently exchanged using VDV standards.

The Berlin system is shown in Figure C.1.

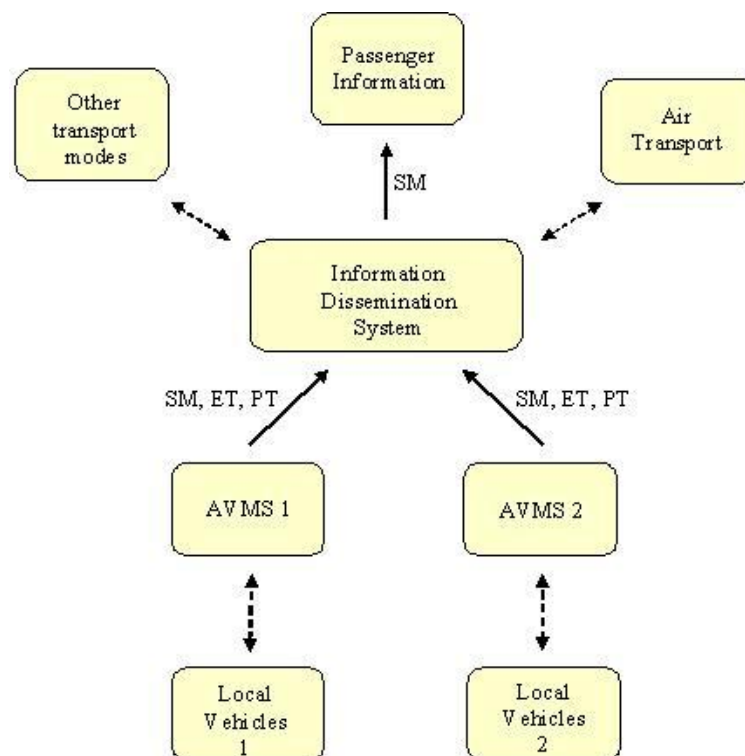

Figure C.1 — Physical deployment example – Berlin

C.4 Deployment Example – Hamburg

A regional public transport plan is produced and provided to the scheduling systems of the two main public transport operators, a regional operator and an urban operator, each with their own AVMS. Information is currently exchanged between the 2 AVMS systems using existing VDV protocols to facilitate Connection Protection and Visualisation of foreign Vehicles. Information is also exchanged between the urban operator and the train company to facilitate connection protection for buses waiting for delayed trains only. Operational Control centres are connected locally to AVMS. The Hamburg system is shown in Figure C.2 below.

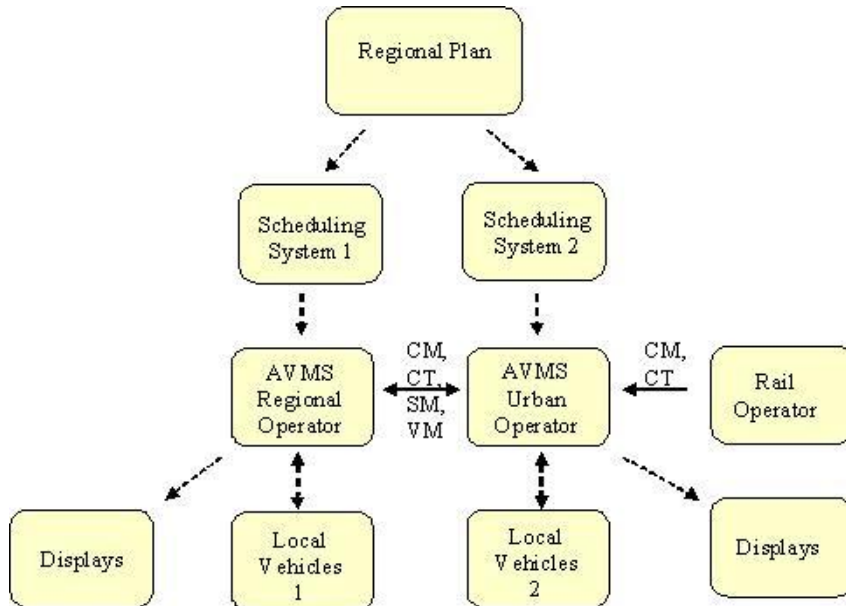

Figure C.2 — Physical deployment example – Hamburg

C.5 Deployment Example – West Yorkshire

This is a large system covering 2 500 vehicles across West and South Yorkshire, and several different participating operators each with their own scheduling system. Information on stops and the transport infrastructure is provided by the local authority. Information is currently exchanged internally between components using standard RTIG protocols, allowing remote delivery of automated voice as well as WAP, Web and SMS services. Traditional displays are driven directly from the system. In future links will be provided to other PT dissemination systems and the PT Journey Planner which are provided by different suppliers.

Information will be exchanged with neighbouring AVMS systems to facilitate roaming vehicles. The Central AVMS may carry out predictions for vehicles from the foreign AVMS for routes within its geographic area. The data protocol from the scheduling system and infrastructure data is not included in the current version of SIRI. Protocols between the Central AVMS and the displays, local vehicles and Traffic Management Centres are proprietary. There are currently 6 participating operators each with their own Operation Control centre linked to the Central AVMS allowing control of only their own vehicles and there will be links to 9 Traffic Management Centres. The West Yorkshire system is shown in Figure C.3 below.

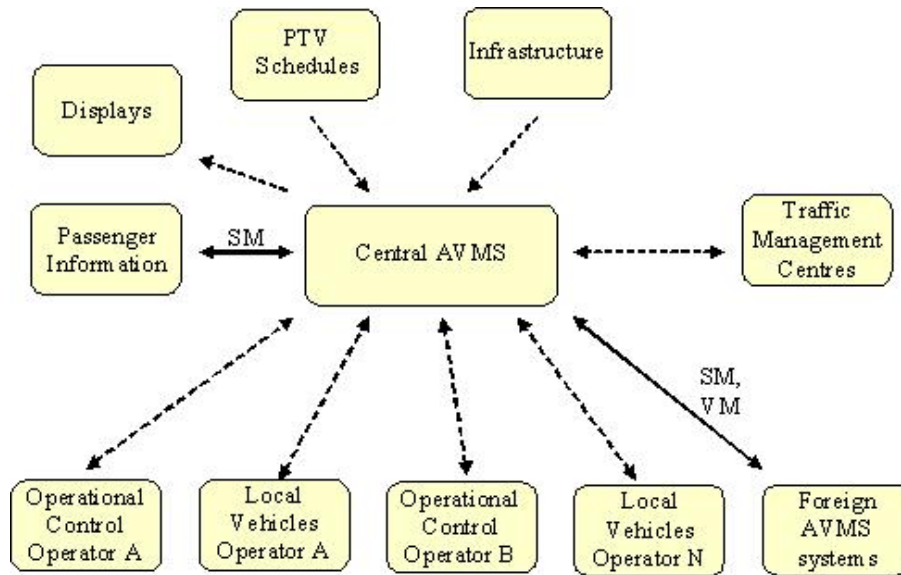

Figure C.3 — Physical deployment example – West Yorkshire

C.6 Deployment Example – Czech Republic

This comprises a central distribution system linked to 3 AVMS, each for a different operator, two of which also share a common radio infrastructure. The AVMS systems directly drive their own passenger displays while the distribution system facilitates exchange of information between different AVMS systems facilitating vehicle roaming and provides information to PT dissemination systems such as information kiosks, public internet, WAP and SMS services. The Czech system is shown in Figure C.4 below.

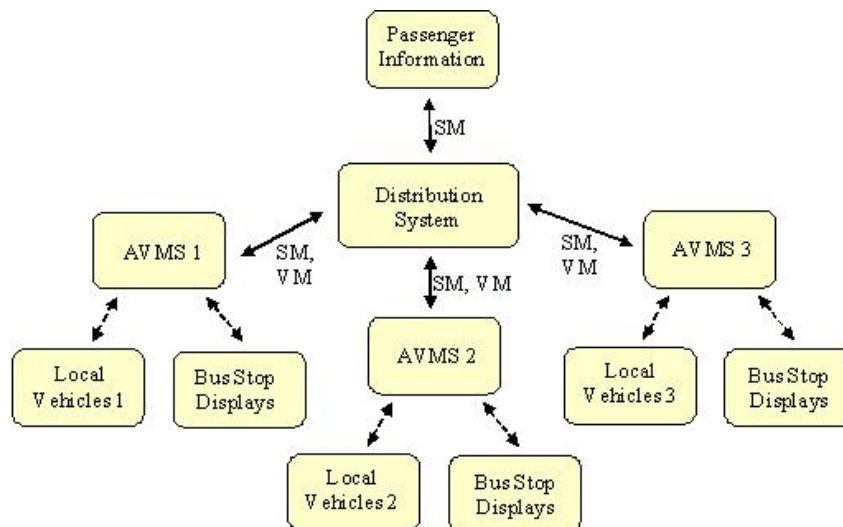

Figure C.4 — Physical deployment example – Czech Republic

C.7 Deployment Example – Copenhagen

Copenhagen uses an integrator model, with a central server connecting to a range of systems including AVMS and Operational Control centres comprising a modular system. The main purpose of using an Integrator is to simplify the integration of multiple systems; to enforce data quality; and to provide a consistent view of data to all connected systems.

The Integrator model is a part of a long term strategy to develop a modular architecture, with each public transport operator free to procure and operate their own AVMS system, which will be fully integrated to the regional information system by interfacing to the Integrator system only.

The Copenhagen system is shown in Figure C.5 below.

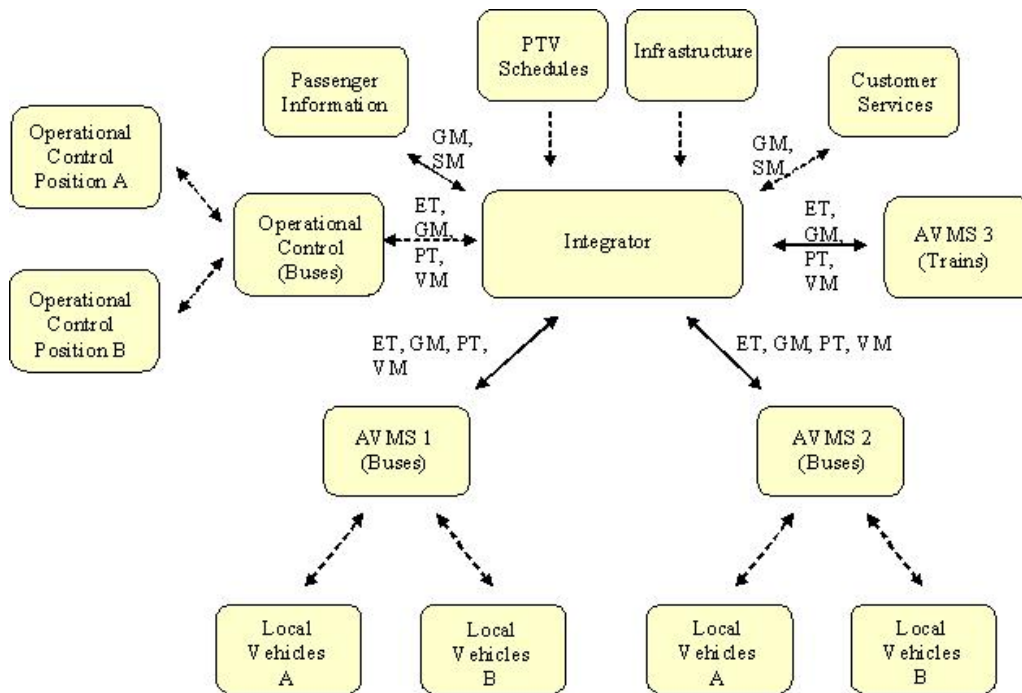

Figure C.5 — Physical deployment example – Copenhagen

Information is collected from each of the systems and disseminated as appropriate. All types of passenger information systems are supplied with all data from the integrator, allowing a flexible modular approach, whereby passenger information systems are independent of source systems.

The Integrator system creates the Integrated PT Plan by combining schedules from several public transport operators, transport infrastructure, and stops and interchange data (collectively called Infrastructure in the diagram). The integrator also combines the vehicle monitoring input from several AVMS, and the input from the Operation Control. Customer Services provides manual intervention to maintain accurate and up-to-date passenger information, in particular in response to disruptions. Both the Operation Control and Customer Services make short term changes in the operation, as Control Actions. These are propagated to all connected systems in real time.

Additionally the Integrator system includes a number of central functions, such as generation of predictions, connection protection, and follows up on the operators’ performance.

Copenhagen uses three different AVMS; two of which are for buses and do not have their own Operation Control functions. Instead, buses are monitored and controlled by an Operation Control system that is

separate from the AVMS. This approach means that a public transport operator can monitor and control their vehicles in one system, regardless of which AVMS that is installed in a vehicle.

Note that SIRI does not currently support Control Actions allowing the remote Operational Control centre to communicate with the AVMS (this is not a problem if the Operational Control is linked directly to the AVMS where proprietary protocols can be used), the results of the control actions in terms of cancelled services etc are however available to be communicated to other systems.

C.8 Deployment example – Île-de-France

The railway real-time information system in Île-de-France is built from a central AVMS linked to multiple local AVMS, provided by several different organizational units. The local AVMS manage all the information about the trains of the regions, drive the displays and transmit this information to other regional AVMS and to the central AVMS.

The central AVMS controls the information broadcast to passengers and provides information to PT dissemination systems such as bus information system, public internet web sites or WAP and SMS services.

The current Île-de-France system is shown in Figure C.6 below.

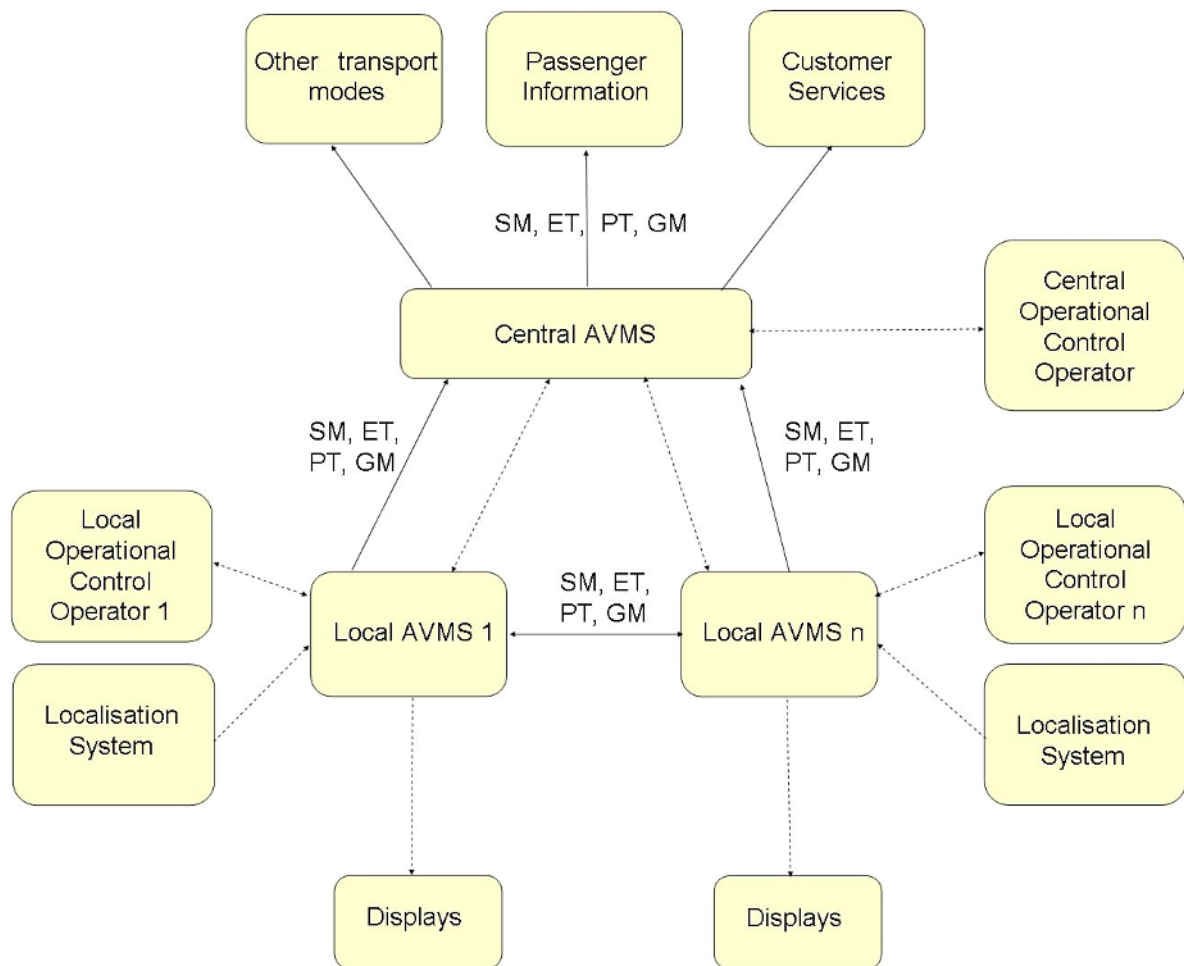

Figure C.6 — Physical deployment example – Île-de-France

The aim is to work towards an “integrator model”, close to the Copenhagen’s system described above. This integrator model will collect information from all the public transport networks: bus (100 operators), rail (SNCF), RER (SNCF/RATP) and subway (RATP). The consolidated information will be then available for passenger information system, content providers, etc.

The targeted Île-de-France system is shown in Figure C.7 below.

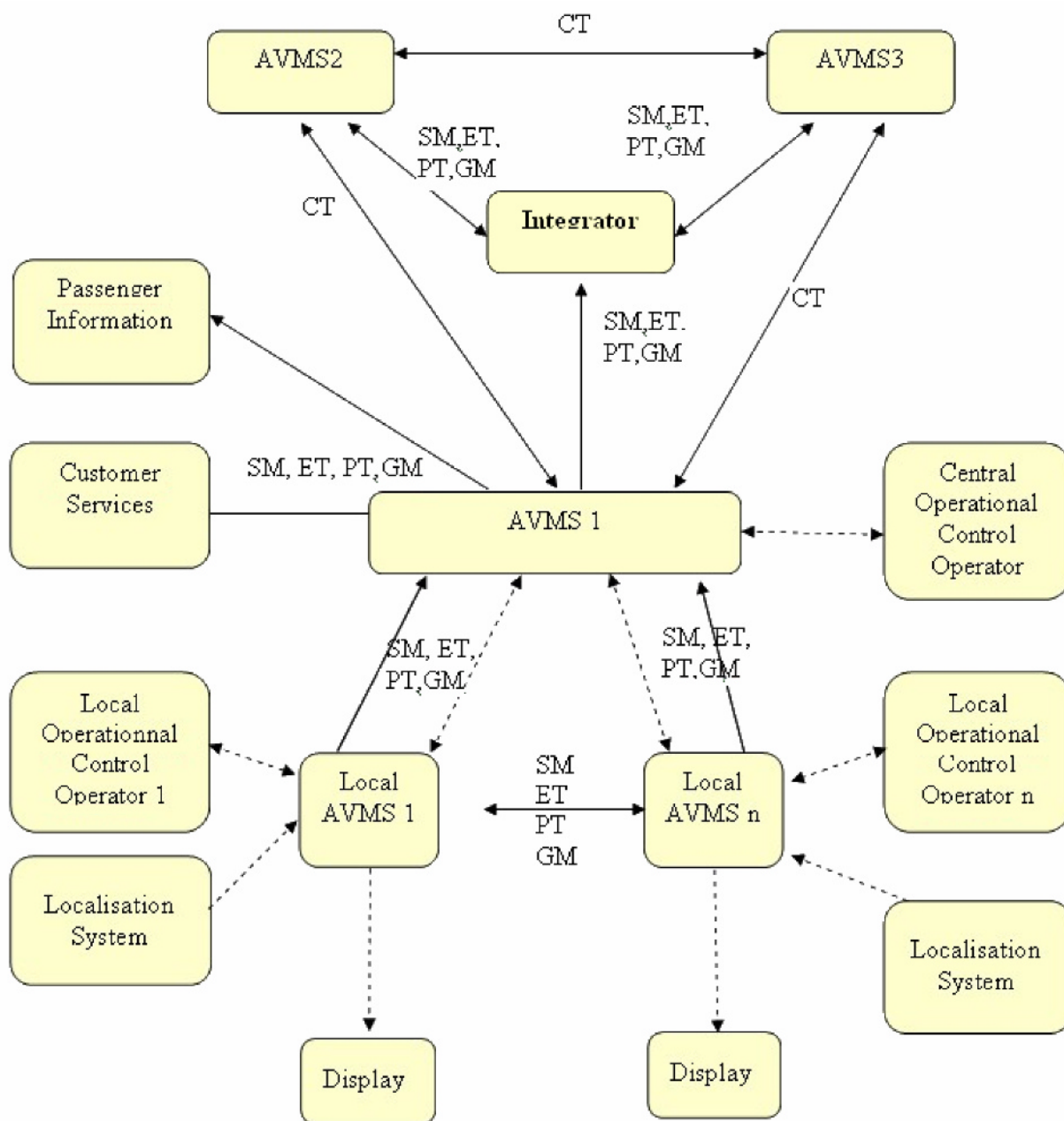

Figure C.7 — Targeted physical deployment example – Île-de-France

C.9 SIRI Equivalences

C.9.1 GTFS-real-time feeds

The Google GTFS-real-time (General Transit Feed Specification Real-time) Services were introduced in 2011 and provide a subset of function equivalent to certain SIRI services. The GTFS-real-time and SIRI services can be regarded as interoperable, that is it should be possible to create adaptors to transform data from a feed in one protocol to a feed in the other protocol. SIRI services are designed for operational systems and contain main additional elements which are not present in the GTFS feeds. The GTFS services are optimized for the distribution of a subset of data of interest to the passenger. The broad correspondences are shown in the following table.

Table C.2 — GTFS & SIRI Functional Service Equivalences

GTFS-real-time Service	SIRI Service	Scope
GTFS-real-time Trip Updates	SIRI –SM Stop Monitoring	Predictions for a stop.
GTFS-real-time Vehicle Positions	SIRI–VM Vehicle Monitoring	Positions for a VEHICLE.
GTFS-real-time Service Alerts	SIRI–SX Situation Exchange	Structured SITUATIONs affecting services.

Bibliography

- [1] CEN/TS 13149-6, *Public transport - Road vehicle scheduling and control systems - Part 6: CAN message content*
- [2] EBSF European Bus System of the Future Detailed specification of a generic EBSF Back-office D3.2.2 2012.02.29]
- [3] EBSF European Bus System of the Future Overall description of Bus on-board and back-office IP network architecture D 2.3.1- D 3.2.1
- [4] EN 28701, *Intelligent transport systems - Public transport - Identification of Fixed Objects in Public Transport (IFOPT)*
- [5] ENV 13998, *Road transport and traffic telematics - Public transport - Non-interactive dynamic passenger information on ground*
- [6] IETF RFC2119, RFC 2119: Key words for use in RFCs to Indicate Requirement Levels
- [7] ISO/IEC 19501, *Information technology - Open Distributed Processing - Unified Modeling Language (UML) Version 1.4.2*
- [8] ISO/IEC 8859-15, *Information technology - 8-bit single-byte coded graphic character sets - Part 15: Latin alphabet No. 9.*
- [9] ISO/TS 24530, *Traffic and Travel Information (TTI) - TTI via Transport Protocol Experts Group (TPEG) Extensible Markup Language (XML)*
- [10] ISO-639 / IETF 1766, Tags for the Identification of Languages
- [11] CEN/TS 16614-1, *Public transport - Network and Timetable Exchange (NeTEx) - Part 1: Public transport network topology exchange format*
- [12] SAE J1939/71, *Bearing in degrees*
- [13] W3C XML, Extensible Mark-up Language (XML) 1.0 W3C Recommendation 04 February 2004, available at <http://www.w3.org/TR/2004/REC-xml-20040204>.
- [14] WGS 1984, World Geodetic Standard 1984, available at <http://www.wgs84.com>
- [15] WS-ADDRESSING, WEB SERVICES ADDRESSING. (WS-Addressing) W3C Member Submission 10 August 2004, available at <http://www.w3.org/Submission/2004/SUBM-ws-addressing-20040810/>
- [16] WS-BaseNotif, W3C Web Services Base Notification
- [17] WS-PubSub, W3C Publish-Subscribe Notification for Web Services
- [18] XML. Extensible Mark-up Language (XML) 1.0 W3C Recommendation 04 February 2004, available at <http://www.w3.org/TR/2004/REC-xml-20040204>

British Standards Institution (BSI)

BSI is the national body responsible for preparing British Standards and other standards-related publications, information and services.

BSI is incorporated by Royal Charter. British Standards and other standardization products are published by BSI Standards Limited.

About us

We bring together business, industry, government, consumers, innovators and others to shape their combined experience and expertise into standards-based solutions.

The knowledge embodied in our standards has been carefully assembled in a dependable format and refined through our open consultation process. Organizations of all sizes and across all sectors choose standards to help them achieve their goals.

Information on standards

We can provide you with the knowledge that your organization needs to succeed. Find out more about British Standards by visiting our website at bsigroup.com/standards or contacting our Customer Services team or Knowledge Centre.

Buying standards

You can buy and download PDF versions of BSI publications, including British and adopted European and international standards, through our website at bsigroup.com/shop, where hard copies can also be purchased.

If you need international and foreign standards from other Standards Development Organizations, hard copies can be ordered from our Customer Services team.

Subscriptions

Our range of subscription services are designed to make using standards easier for you. For further information on our subscription products go to bsigroup.com/subscriptions.

With **British Standards Online (BSOL)** you'll have instant access to over 55,000 British and adopted European and international standards from your desktop. It's available 24/7 and is refreshed daily so you'll always be up to date.

You can keep in touch with standards developments and receive substantial discounts on the purchase price of standards, both in single copy and subscription format, by becoming a **BSI Subscribing Member**.

PLUS is an updating service exclusive to BSI Subscribing Members. You will automatically receive the latest hard copy of your standards when they're revised or replaced.

To find out more about becoming a BSI Subscribing Member and the benefits of membership, please visit bsigroup.com/shop.

With a **Multi-User Network Licence (MUNL)** you are able to host standards publications on your intranet. Licences can cover as few or as many users as you wish. With updates supplied as soon as they're available, you can be sure your documentation is current. For further information, email bsmusales@bsigroup.com.

BSI Group Headquarters

389 Chiswick High Road London W4 4AL UK

Revisions

Our British Standards and other publications are updated by amendment or revision.

We continually improve the quality of our products and services to benefit your business. If you find an inaccuracy or ambiguity within a British Standard or other BSI publication please inform the Knowledge Centre.

Copyright

All the data, software and documentation set out in all British Standards and other BSI publications are the property of and copyrighted by BSI, or some person or entity that owns copyright in the information used (such as the international standardization bodies) and has formally licensed such information to BSI for commercial publication and use. Except as permitted under the Copyright, Designs and Patents Act 1988 no extract may be reproduced, stored in a retrieval system or transmitted in any form or by any means – electronic, photocopying, recording or otherwise – without prior written permission from BSI. Details and advice can be obtained from the Copyright & Licensing Department.

Useful Contacts:

Customer Services

Tel: +44 845 086 9001

Email (orders): orders@bsigroup.com

Email (enquiries): cservices@bsigroup.com

Subscriptions

Tel: +44 845 086 9001

Email: subscriptions@bsigroup.com

Knowledge Centre

Tel: +44 20 8996 7004

Email: knowledgecentre@bsigroup.com

Copyright & Licensing

Tel: +44 20 8996 7070

Email: copyright@bsigroup.com



...making excellence a habit.™