

Railway applications — Designation system for railway vehicles —

Part 1: General principles

The European Standard EN 15380-1:2006 has the status of a
British Standard

ICS 01.110; 45.060.01

National foreword

This British Standard is the official English language version of EN 15380-1:2006.

The UK participation in its preparation was entrusted to Technical Committee RAE/1, Railway applications, which has the responsibility to:

- aid enquirers to understand the text;
- present to the responsible international/European committee any enquiries on the interpretation, or proposals for change, and keep UK interests informed;
- monitor related international and European developments and promulgate them in the UK.

A list of organizations represented on this committee can be obtained on request to its secretary.

This standard has been produced from Part 1 of the DIN 25002 series of standards under the CEN fast-track procedure. The UK voted against the document in both associated ballots stating that the translation of the documents from German to prepare the English version had resulted in a lack of clarity as to the intent and meaning of some of the terminology used. There is a concern that some of the railway-related terminology used does not correspond to UK usage. Therefore, this standard should be applied with care and consideration in order to avoid misunderstanding.

Cross-references

The British Standards which implement international or European publications referred to in this document may be found in the *BSI Catalogue* under the section entitled “International Standards Correspondence Index”, or by using the “Search” facility of the *BSI Electronic Catalogue* or of British Standards Online.

This publication does not purport to include all the necessary provisions of a contract. Users are responsible for its correct application.

Compliance with a British Standard does not of itself confer immunity from legal obligations.

Summary of pages

This document comprises a front cover, an inside front cover, the EN title page, pages 2 to 22, an inside back cover and a back cover.

The BSI copyright notice displayed in this document indicates when the document was last issued.

Amendments issued since publication

Amd. No.	Date	Comments

This British Standard was published under the authority of the Standards Policy and Strategy Committee on 31 August 2006

© BSI 2006

ISBN 0 580 48942 6

ICS 01.110; 45.060.01

English Version

Railway applications - Designation system for railway vehicles - Part 1: General principles

Applications ferroviaires - Système de classification pour
véhicules ferroviaires - Partie 1: Règles générales

Bahnanwendungen - Kennzeichnungssystematik für
Schienenfahrzeuge - Teil 1: Grundlagen

This European Standard was approved by CEN on 6 March 2006.

CEN members are bound to comply with the CEN/CENELEC Internal Regulations which stipulate the conditions for giving this European Standard the status of a national standard without any alteration. Up-to-date lists and bibliographical references concerning such national standards may be obtained on application to the Central Secretariat or to any CEN member.

This European Standard exists in three official versions (English, French, German). A version in any other language made by translation under the responsibility of a CEN member into its own language and notified to the Central Secretariat has the same status as the official versions.

CEN members are the national standards bodies of Austria, Belgium, Cyprus, Czech Republic, Denmark, Estonia, Finland, France, Germany, Greece, Hungary, Iceland, Ireland, Italy, Latvia, Lithuania, Luxembourg, Malta, Netherlands, Norway, Poland, Portugal, Romania, Slovakia, Slovenia, Spain, Sweden, Switzerland and United Kingdom.



EUROPEAN COMMITTEE FOR STANDARDIZATION
COMITÉ EUROPÉEN DE NORMALISATION
EUROPÄISCHES KOMITEE FÜR NORMUNG

Management Centre: rue de Stassart, 36 B-1050 Brussels

Contents

Page

Foreword.....4

1 Scope5

2 Normative references6

3 Terms and definitions7

4 General principles of the designation system8

4.1 General.....8

4.2 Structuring of the designation8

5 Rules for the structure of designation sets9

6 Structure and content of the designation sets9

6.1 General.....9

6.2 Function aspect9

6.2.1 "Function-oriented structure" designation set.....9

6.3 Product aspect10

6.3.1 "Product" designation set10

6.3.2 "Object" designation set.....11

6.4 Location aspect.....12

6.4.1 "Installation site" designation set.....12

6.4.2 "Location" designation set13

6.5 "Document type" designation set.....14

7 Application of designations.....15

7.1 Combination of designation sets15

7.2 Format of the designations.....16

7.2.1 Format in the technical documents16

7.2.2 Format in the installation16

Annex A (informative) Rolling stock fleet designation.....17

Annex B (informative) Examples of designation formats18

Annex C (informative) Relationships between the different aspects.....20

Bibliography22

List of Tables

Table C.1 — Product life cycle of the railway vehicle 21

List of Figures

Figure 1 — Structure and content of the "Function-oriented structure" designation set 10

Figure 2 — Structure and content of the "Product" designation set 10

Figure 3 — Structure and content of the "Object" designation set..... 11

Figure 4 — Structure and content of the "Installation site" designation set 12

Figure 5 — Structure and content of the "Location" designation set.....	13
Figure 6 — Structure and content of the "Document type" designation set	14
Figure 7 — Combination of different designation sets	15
Figure A.1 — Example of "Railway vehicle" installation complex designation.....	17
Figure A.2 — Example of rolling stock fleet designation.....	17
Figure B.1 — Document designation in the drawing title block	18
Figure B.2 — Document designation of circuit documentation, circuit diagrams in the drawing title block	18
Figure B.3 — Document designation in the parts list title block.....	18
Figure B.4 — Document designation of wiring tables and object lists in the title block.....	19
Figure B.5 — Document designation of technical documents	19
Figure C.1 — Relationships between the relevant standards.....	20

Foreword

This document (EN 15380-1:2006) has been prepared by Technical Committee CEN/TC 256 "Railway applications", the secretariat of which is held by DIN.

This document shall be given the status of a national standard, either by publication of an identical text or by endorsement, at the latest by October 2006, and conflicting national standards shall be withdrawn at the latest by October 2006.

At the request of DIN, this European Standard has been submitted to the PQ procedure and has been approved as there have been no comparable standards in Europe to date.

The EN 15380 series of standards, *Railway applications – Designation system for railway vehicles* consists of:

- *Part 1: General principles*
- *Part 2: Product groups*
- *Part 3: Designation of installation sites and locations*

This European Standard is based on Part 1 of the DIN 25002 series of standards. After approval, the text of DIN 25002-1 submitted to the PQ procedure was brought into line with the formal requirements of an EN. The resulting editorial amendments have led to slightly modified wordings but they have no effect on the technical content of this document.

According to the CEN/CENELEC Internal Regulations, the national standards organizations of the following countries are bound to implement this European Standard: Austria, Belgium, Cyprus, Czech Republic, Denmark, Estonia, Finland, France, Germany, Greece, Hungary, Iceland, Ireland, Italy, Latvia, Lithuania, Luxembourg, Malta, Netherlands, Norway, Poland, Portugal, Romania, Slovakia, Slovenia, Spain, Sweden, Switzerland and the United Kingdom.

Introduction

This European Standard has created a uniform, general facility for classifying railway vehicles suitable for all project viewpoints. The following aspects are used as project viewpoints:

- function viewpoint and/or
- product viewpoint and/or
- location viewpoint.

This standard forms the basis for:

- definitions of requirements, tenders, contracts, specifications;
- creation of standard sub-systems;
- design (requirements, specifications);
- demarcation of areas of responsibility;
- product planning support;
- project planning support;
- comparison of different system solutions;
- maintenance and repair specifications;
- reliability studies, data acquisition;
- allocation of equipment to functions;
- designation of functions, products and locations .

1 Scope

As a railway-specific technical standard, this European Standard specifies the designation system for technical products and technical project documentation. It takes into account the general rules for structuring principles according to EN 61346-1 and designations according to EN 61355.

The European Standard specifies the structure and content of the designation sets required in the technical project documentation.

The designation depends on the aspect used, see Annex C, individually or in designation set combinations, i.e.:

- product groups according to EN 15380-2;
- installation site/location according to EN 15380-3;
- function structure according to DIN 25002-5.

2 Normative references

The following referenced documents are indispensable for the application of this European Standard. For dated references, only the edition cited applies. For undated references, the latest edition of the referenced document (including any amendments) applies.

EN 15380-2, *Railway applications – Designation system for railway vehicles – Part 2: Product groups*

EN 15380-3:2006, *Railway applications – Designation system for railway vehicles – Part 3: Designation of installation sites and locations*

EN 61082-1, *Preparation of documents used in electrotechnology – Part 1: General requirements Amendment A2 (IEC 61082-1:1991)*

EN 61346-1, *Industrial systems, installations and equipment and industrial products – Structuring principles and reference designations - Part 1: Basic rules (IEC 61346-1:1996)*

EN 61346-2:2000, *Industrial systems, installations and equipment and industrial products - Structuring principles and reference designations – Part 2: Classification of objects and codes for classes (IEC 61346-2:2000)*

EN 61355, *Classification and designation of documents for plants, systems and equipment (IEC 61355:1997)*

ISO/IEC 8859-1, *Information technology – 8-bit single-byte coded graphic character sets – Part 1: Latin alphabet No. 1*

DIN 25002-3:2001, *Railway applications – Designation system for rail vehicles – Part 3: Classification of documents¹⁾*

DIN 25002-5, *Railway applications – Designation system for rail vehicles – Part 5: Function groups¹⁾*

1) Available from: Beuth Verlag GmbH, D-10772 Berlin

3 Terms and definitions

For the purposes of this document, the terms and definitions given in EN 61346-2:2000 and the following apply.

3.1

subclass

part of a class in a designation set; combination of data positions in the designation hierarchy

[EN 61346-2:2000]

3.2

installation

combination of technical devices; installations can be divided into subinstallations

3.3

installation complex

consists of several equivalent installations or installations working together

NOTE For the purposes of this standard, this always means the complete railway vehicle ready for operation

3.4

installation site

topographic position of vehicle units, structural units and combined assemblies in a closed train composition

3.5

object

smallest entity treated that is designated in a technical product that fulfils a task (e.g. lifting, lowering, measuring, controlling) together with other products. For the purposes of this standard, this does not mean tools, clamp meters, machine tools or inventory, for example

3.6

data position

position for writing down an alphabetical, numerical or special character

3.7

location

information on the spatial position of an object, of a structural unit, of a technical device in a combination group, e.g. axle, driver's desk

3.8

functional assignment for railway vehicles

linking of related functions between the installation complexes of a rail transport system

3.9

common assignment for railway vehicles

combination of all installation complexes to form one rail transport system

3.10

class

part of a designation set; combination of subclasses in the designation hierarchy

3.11

classification character

subdivides classes for better comprehension

3.12
code letter

an alphabetical character (Latin upper case letters excluding I and O) used for classification

3.13
designation

designation set or combination of several designation sets used for the coded representation of designation tasks and certain information

3.14
designation set

a classified combination of correlated information

3.15
railway vehicle

track-bound vehicle guided and borne on rails

NOTE Trolley buses are regarded as railway vehicles.

3.16
rail transport system

land-bound transport system for conveying passengers and goods between fixed locations with fixed, movable and logistical devices (see common assignment)

3.17
technical device

structural and/or functional combination of objects for fulfilling a technical task

3.18
subinstallation

part of an installation

3.19
prefix sign

identifies (names) the smallest designated entity treated

4 General principles of the designation system

4.1 General

The basic principles for the designation of functions, products and locations shall be taken into account according to EN 61346-1.

4.2 Structuring of the designation

These designations are structured according to the following criteria:

- function-oriented structure (=);
- product-oriented structure (-);
- location-oriented structure (+).

The structures have equal status and are independent of each other. The designation corresponds to the task set. The designation can be used singly or in a combination. However, it is not necessary always to use all possible designations.

The prefix sign "&" according to EN 61355 is used for designating the document type. Prefix signs for other designation tasks are given in EN 61346-2.

5 Rules for the structure of designation sets

The following rules apply based on EN 61346-1 and EN 61346-2

Rule 1: The designation sets are identified by prefix signs, with their own data positions.

Rule 2: The designation sets are subdivided into classes. These consist of one or more subclasses. Within one designation set, the entities decreasing in interest are designated from left to right.

Rule 3: Each subclass consists of a maximum of three data positions not all of which, however, have to be written, depending on the case. Within a subclass, only alphabetical (A) or numerical (N) characters are permitted.

Rule 4: Only Latin upper cases letters from A to Z excluding "I" and "O" are permitted as alphabetical data positions. For numerical data positions, Arabic numerals are used.

Rule 5: Subclasses at the beginning and/or end of a designation set can be omitted. The rules on this are specified in this technical standard.

Rule 6: Certain designation sets are subdivided between classes by the classification character "." with its own data position. If the designation set is subdivided by the classification character "." (ASCII Code 46 according to ISO/IEC 8859-1), rule 5 applies for the parts of the designation set to the left and right of the classification character.

NOTE The combination of designation sets and the method of writing the characters are described in clause 7.

6 Structure and content of the designation sets

6.1 General

The structure and content of the designation sets are illustrated in the following subclauses. For the individual designation sets, the structure specified for railway vehicles is illustrated in each case with the number of the subclasses and data positions used.

NOTE See Annexes B and C.

6.2 Function aspect

6.2.1 "Function-oriented structure" designation set

This designation set is used to designate functional relationships between the functional agents of a railway vehicle; a new draft is in preparation. The structure is shown in Figure 1.

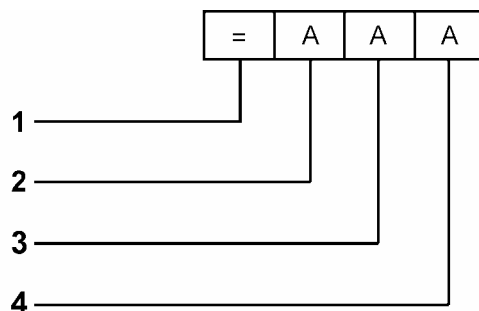

Key

- 1 Prefix sign
- 2 Main function group according to DIN 25002-5
- 3 Part function group according to DIN 25002-5
- 4 Sub-function group according to DIN 25002-5

Figure 1 — Structure and content of the "Function-oriented structure" designation set

6.3 Product aspect

6.3.1 "Product" designation set

This designation set is used to designate complex products and technical devices as a function. It is used for classification from the viewpoint of structure and arrangement of the complex products and technical devices, see Figure 2.

For railway vehicles, this designation also contains combined assemblies fulfilling more than one function.

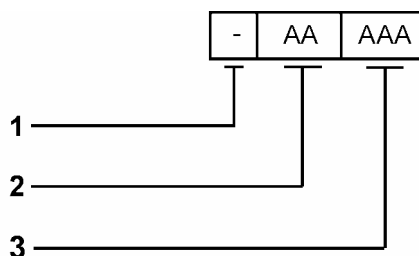

Key

- 1 Prefix sign
- 2 Product group according to EN 15380-2
- 3 Serial number

Figure 2 — Structure and content of the "Product" designation set

EXAMPLE 1

-	CE	001
---	----	-----

- CE 001

Partitions CE, Partition 001

- Prefix sign

CE Product group

001 Serial number

EXAMPLE 2

-	GB	
---	----	--

- GB

Power supply control, pantograph control GB

- Prefix sign

GB Product group

6.3.2 "Object" designation set

This designation set is used to designate objects as shown in Figure 3.

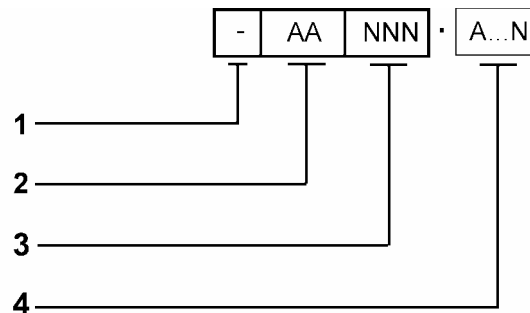
**Key**

- 1 Prefix sign
- 2 Product group according to EN 15380-2
- 3 Serial number
- 4 Designation of objects

Figure 3 — Structure and content of the "Object" designation set

EXAMPLE 1

-	NB	004
---	----	-----

- NB 004

Pipe support NB, serial number 004

- Prefix sign

NB Product group

004 Serial number
 EXAMPLE 2

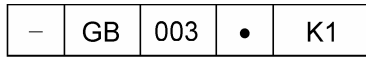

– **GB 003 • K1**
 Pantograph GB, serial number 003, relay K, serial number 1 (001)

- Prefix sign
- GB Product group
- 003 Serial number
- Prefix sign
- K1 Serial number, for electrical objects, name of the object also

EXAMPLE 3



– **GB • K1**
 Pantograph GB, relay K, serial number 1 (001)

- Prefix sign
- GB Product group
- Prefix sign
- K1 Serial number, for electrical objects, name of the object also

6.4 Location aspect

6.4.1 "Installation site" designation set

This designation set is used to identify the relative location. It is only required for trains composed of vehicles that are continuously coupled or articulated for operation.

This designation specifies the position of a vehicle unit or a structural unit in a closed train composition, see Figure 4.

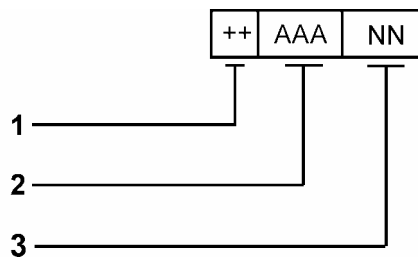

Key

- 1 Prefix sign
- 2 Specific train
- 3 Location within the closed train composition according to EN 15380-3

Figure 4 — Structure and content of the "Installation site" designation set

EXAMPLE

++	RAD	02
----	-----	----

++RAD 02

High-speed train RA, centre car D02

Details of the installation site in a closed train composition, see Annex A.

++	Installation site
R	Rolling stock fleet
A	High-speed train
D	Centre car
02	Vehicle 02

6.4.2 "Location" designation set

This designation set is used to designate the locations of technical products (combined assemblies, structural units, objects), see Figure 5.

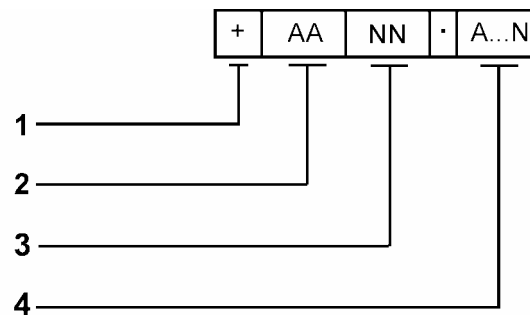
**Key**

- 1 Prefix sign
- 2 Product group according to EN 15380-2
- 3 Subdivision of the locations in a vehicle by designation according to EN 15380-3
- 4 Designation of the locations, combined assemblies, structural units and objects, not specified

Figure 5 — Structure and content of the "Location" designation set

EXAMPLE 1

+	EA	72	.	W1L
---	----	----	---	-----

+ EA72.W1L

Running gear EA, location underframe, axle shaft 1 left-hand side

+	Location
EA	Running gear
72	Location underframe
.	Classification character
W1L	Axle shaft 1 left-hand side

EXAMPLE 2

+	11			
---	----	--	--	--

+ 11
Location driver's desk

+ Location
11 Driver's desk

NOTE See also EN 15380-3:2006, Figure 4.

6.5 "Document type" designation set

This designation set is used to designate types of documents according to the information they contain (e.g. circuit diagrams, dimension drawings, painting instructions), regardless of the kind of storage media on which the documents are located, see Figure 6.

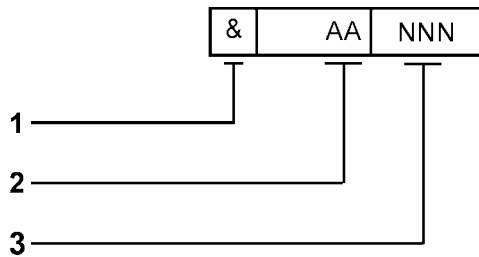

Key

- 1 Prefix sign
- 2 Code letter for document type classes according to Table 1 of DIN 25002-3:2001
- 3 Document type serial number

Figure 6 — Structure and content of the "Document type" designation set

EXAMPLE 1

&	TB	007
---	----	-----

& TB 007
Construction drawing TB007

& Prefix sign
T Document for describing geometrical shapes
B Construction drawing
007 Document type serial number

EXAMPLE 2

&	FS	001
---	----	-----

& FS001

Circuit diagram FS001

&	Prefix number
F	Documents describing function
S	Circuit diagram
001	Document type serial number

7 Application of designations**7.1 Combination of designation sets**

Individual designation sets of combinations of them can be used depending on the task and designation extent of the technical products to be designated.

What characterizes the combination designation is the smallest designated entity treated.

Examples of typical combinations of different designation sets are shown in Figure 7.

Installation site and location	++ <input type="text"/> + <input type="text"/>
Product group and equipment	- <input type="text"/> · <input type="text"/>
Location and equipment	+ <input type="text"/> - <input type="text"/>
Functional group and document type	= <input type="text"/> & <input type="text"/>
Product group and document type	- <input type="text"/> & <input type="text"/>
Location and document type	+ <input type="text"/> & <input type="text"/>
Equipment and document type	- <input type="text"/> & <input type="text"/>

Figure 7 — Combination of different designation sets

7.2 Format of the designations

Depending on the particular requirement, the designation sets are written down singly, in combinations, joined up or separated with their prefix signs. Prefix signs can be omitted if the designations remain unambiguous, e. g. in tables.

A separated format means splitting the designation in a document or on the technical devices or locations or objects.

A separated format is only permitted if the designation remains unambiguous.

7.2.1 Format in the technical documents

Designations can be written:

- in the title block or at a defined point in the drawing;
- on frame lines, separating lines, break points;
- in tables;
- on graphical symbols.

With the separated format, the complete designation is made up of the part designations of the larger entities in the title block or at a defined point in the drawing and part designations of the smaller entities at other places in the document, e.g. on the frame line, the graphical symbol, the break point.

Designations that are not combined with the designation in the title block or at the defined point in the drawing box shall always be written in full.

Rules for the format at break points, for notes and for abbreviations or separated format are specified in EN 61082-1.

7.2.2 Format in the installation

In areas, on technical devices, locations and objects, complete designations shall only be written if it is necessary to be able to give an unambiguous reference to the documentation for operating the installation. A separated format is permitted. For this, the requirements of 7.2.1 apply as appropriate.

Annex A (informative)

Rolling stock fleet designation

The following code letters are proposed for the "railway vehicles" installation complex, see Figures A.1 and A.2.

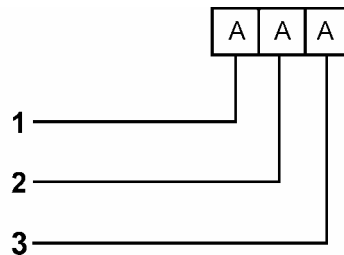

Key

- 1 Designation of the installation complex (railway vehicles)
- 2 Type of installation complex (rolling stock fleet)
- 3 Further subdivision (e.g. vehicle type)

Figure A.1 — Example of "Railway vehicle" installation complex designation

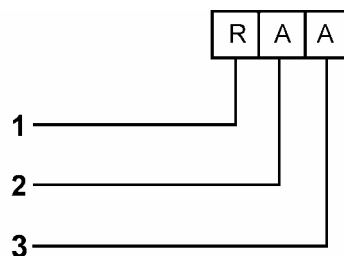

Key

- 1 Railway vehicles
- 2 Rolling stock fleet, differentiated by the following criteria:
 - A High-speed train
 - B Conventional train (regional train, suburban train)
 - C Passenger coach
 - E Tram, urban railway
 - F Underground, metro
 - H Locomotive
 - V Special vehicle
 - Z Freight wagon
- 3 Type of vehicle, freely selectable

Figure A.2 — Example of rolling stock fleet designation

Annex B (informative)

Examples of designation formats

For the various designations of the technical documents taking as an example the swing plug door from the viewpoint of the different documents, see Figures B.1 to B.5.

Drawing shall only be amended in the CAD system											
			Tolerancing ISO 8015 General tolerances								
			Origin			Replacement for			Replaced by		
									& TB		
									- NB		
Index		Amd. No.		Date		Name					
Scale 1:1		Drawn						Swing plug door			
		Checked									
		Released									
		Date		Name							
		en/									

Figure B.1 — Document designation in the drawing title block

				Date	Applicable for		Door control circuit			= FS 003					
				Drawn									+		
				Ch.						Ed.			Sheet		
Issue	Amd.	Date	Name	Rel.	Origin	Repl. for	Repl. by	Date				Sh			

Figure B.2 — Document designation of circuit documentation, circuit diagrams in the drawing title block

Drawn				Swing plug door								
Checked												
Approved												
		Date	Name	DCC			& TB			p/n		Index

Figure B.3 — Document designation in the parts list title block

Edition				DATE					Sheet
Issue.				Drawn				Wiring table	
-MB 001 & MB 003				Ch./Rel.					Sh

Figure B.4 — Document designation of wiring tables and object lists in the title block

Originator <i>Factory/location</i>	Comp. authority <i>Department</i>	Doc. type Technical data sheet	Doc. code & DA 003	<i>Company name or company logo</i>
Drawn: <i>Date for contractor</i>		Swing plug door ti2 ti3	Doc. status <i>e.g. released</i>	
Checked: <i>Date for contractor</i>			Contractor's ID number	
Released: <i>Date for contractor</i>		File name: <i>500 vl.DOT.doc</i>	Amendment: Lang. Page: <i>Index/Date en 18/n</i>	
Customer: ID No.	<i>Company name/logo</i> <i>Customer's number</i>	Date: Approved <i>Cust. for customer</i>	Edition: Date: <i>No. Cust.</i>	
Applicable for		Replacement for		

Figure B.5 — Document designation of technical documents

Annex C (informative)

Relationships between the different aspects

The basic rules given in EN 61346-1 for the equivalent aspects of the function-oriented structure, the product-oriented structure and the location-oriented structure are specified in DIN 25002-5, EN 15380-2 and EN 15380-3 for application with railway vehicles. The technical project documentation according to EN 61355 is applicable in parallel to all the aspects.

Figure C.1 shows the equivalence and independence of the aspects and the classification of document types within the overall framework of EN 15380-1.

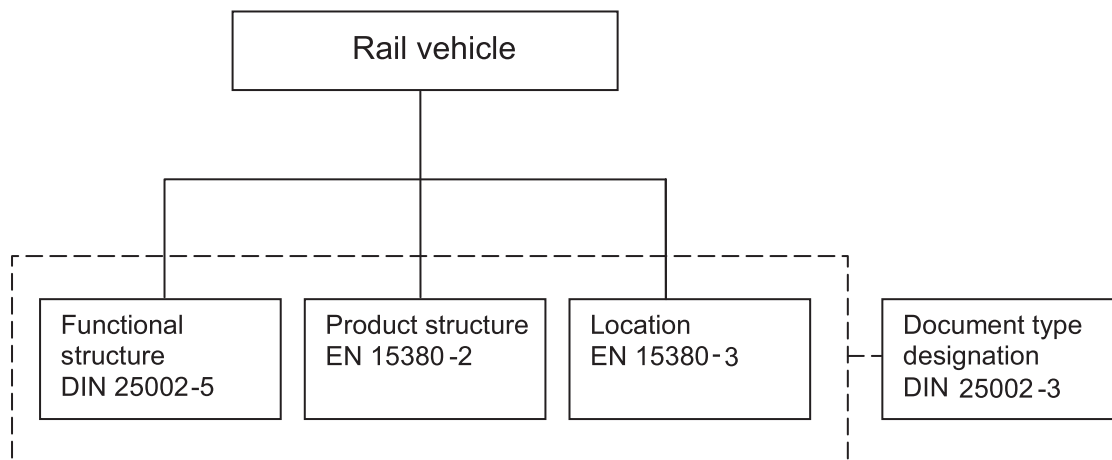

Figure C.1 — Relationships between the relevant standards

The following Table C.1 shows the main points in the application of the different aspects.

The equivalent and independent aspects are weighted differently in the various phases of the project life cycle. This can range from the use of only one aspect to the equivalent use of all the independent aspects. Table C.1 shows, as an example, 15 phases of the project life cycle with varying importance of the aspects.

Table C.1 — Product life cycle of the railway vehicle

Lift cycle phase	Aspect		
	Function	Product	Location
Functional specifications (call for tenders)	x		
Draft/offer	x	x	x
Standard specifications	x	x	x
Development (system design)	x		x
Design	x	x	x
Material procurement/purchase	x	x	
Pre-assembly		x	
Preliminary test	x	x	
Vehicle assembly		x	X
Commissioning/testing/acceptance	x	x	X
Service	x		
Troubleshooting	x	x	X
Maintenance	x	x	X
Repair	x	x	X
Recycling		x	

Bibliography

- [1] EN 60445:2000, *Basic and safety principles for man-machine interface, marking and identification – Identification of equipment terminals and of terminations of certain designated conductors, including general rules for an alphanumeric system (IEC 60445:1999)*

www.pearsoned.com

BSI — British Standards Institution

BSI is the independent national body responsible for preparing British Standards. It presents the UK view on standards in Europe and at the international level. It is incorporated by Royal Charter.

Revisions

British Standards are updated by amendment or revision. Users of British Standards should make sure that they possess the latest amendments or editions.

It is the constant aim of BSI to improve the quality of our products and services. We would be grateful if anyone finding an inaccuracy or ambiguity while using this British Standard would inform the Secretary of the technical committee responsible, the identity of which can be found on the inside front cover.
Tel: +44 (0)20 8996 9000. Fax: +44 (0)20 8996 7400.

BSI offers members an individual updating service called PLUS which ensures that subscribers automatically receive the latest editions of standards.

Buying standards

Orders for all BSI, international and foreign standards publications should be addressed to Customer Services. Tel: +44 (0)20 8996 9001.
Fax: +44 (0)20 8996 7001. Email: orders@bsi-global.com. Standards are also available from the BSI website at <http://www.bsi-global.com>.

In response to orders for international standards, it is BSI policy to supply the BSI implementation of those that have been published as British Standards, unless otherwise requested.

Information on standards

BSI provides a wide range of information on national, European and international standards through its Library and its Technical Help to Exporters Service. Various BSI electronic information services are also available which give details on all its products and services. Contact the Information Centre.
Tel: +44 (0)20 8996 7111. Fax: +44 (0)20 8996 7048. Email: info@bsi-global.com.

Subscribing members of BSI are kept up to date with standards developments and receive substantial discounts on the purchase price of standards. For details of these and other benefits contact Membership Administration.
Tel: +44 (0)20 8996 7002. Fax: +44 (0)20 8996 7001.
Email: membership@bsi-global.com.

Information regarding online access to British Standards via British Standards Online can be found at <http://www.bsi-global.com/bsonline>.

Further information about BSI is available on the BSI website at <http://www.bsi-global.com>.

Copyright

Copyright subsists in all BSI publications. BSI also holds the copyright, in the UK, of the publications of the international standardization bodies. Except as permitted under the Copyright, Designs and Patents Act 1988 no extract may be reproduced, stored in a retrieval system or transmitted in any form or by any means – electronic, photocopying, recording or otherwise – without prior written permission from BSI.

This does not preclude the free use, in the course of implementing the standard, of necessary details such as symbols, and size, type or grade designations. If these details are to be used for any other purpose than implementation then the prior written permission of BSI must be obtained.

Details and advice can be obtained from the Copyright & Licensing Manager.
Tel: +44 (0)20 8996 7070. Fax: +44 (0)20 8996 7553.
Email: copyright@bsi-global.com.