

# Determination of the influence of the corrosion protection coating on the anchorage capacity of the transverse anchorage bars in prefabricated reinforced components of autoclaved aerated concrete

The European Standard EN 15361:2007 has the status of a British Standard

ICS 91.100.30

## National foreword

This British Standard was published by BSI. It is the UK implementation of EN 15361:2007.

The UK participation in its preparation was entrusted to Technical Committee B/523, Prefabricated components of reinforced autoclaved aerated concrete and lightweight aggregate concrete with open structure.

A list of organizations represented on this committee can be obtained on request to its secretary.

This publication does not purport to include all the necessary provisions of a contract. Users are responsible for its correct application.

**Compliance with a British Standard cannot confer immunity from legal obligations.**

This British Standard was published under the authority of the Standards Policy and Strategy Committee on 30 April 2007

© BSI 2007

ISBN 978 0 580 50637 6

### Amendments issued since publication

Amd. No.	Date	Comments

English Version

Determination of the influence of the corrosion protection coating on the anchorage capacity of the transverse anchorage bars in prefabricated reinforced components of autoclaved aerated concrete

Détermination de l'influence de la protection contre la corrosion sur la capacité d'ancrage des barres d'ancrage transversales dans les composants préfabriqués en béton cellulaire autoclavé armé

Bestimmung des Einflusses des Korrosionsschutzüberzugs auf die aufnehmbare Verankerungskraft der zur Verankerung benutzten Querstäbe in vorgefertigten bewehrten Bauteilen aus dampfgehärtetem Porenbeton

This European Standard was approved by CEN on 24 February 2007.

CEN members are bound to comply with the CEN/CENELEC Internal Regulations which stipulate the conditions for giving this European Standard the status of a national standard without any alteration. Up-to-date lists and bibliographical references concerning such national standards may be obtained on application to the CEN Management Centre or to any CEN member.

This European Standard exists in three official versions (English, French, German). A version in any other language made by translation under the responsibility of a CEN member into its own language and notified to the CEN Management Centre has the same status as the official versions.

CEN members are the national standards bodies of Austria, Belgium, Bulgaria, Cyprus, Czech Republic, Denmark, Estonia, Finland, France, Germany, Greece, Hungary, Iceland, Ireland, Italy, Latvia, Lithuania, Luxembourg, Malta, Netherlands, Norway, Poland, Portugal, Romania, Slovakia, Slovenia, Spain, Sweden, Switzerland and United Kingdom.



EUROPEAN COMMITTEE FOR STANDARDIZATION  
COMITÉ EUROPÉEN DE NORMALISATION  
EUROPÄISCHES KOMITEE FÜR NORMUNG

Management Centre: rue de Stassart, 36 B-1050 Brussels

**Contents**

Page

Foreword.....3

1 Scope .....4

2 Normative references .....4

3 Principle .....4

4 Apparatus .....4

5 Test specimens .....5

5.1 General.....5

5.2 Measurement of the mean outer diameter of the transverse bar with the corrosion protection coating.....5

5.3 Shape, size and preparation of test specimens .....5

5.4 Conditioning of test specimens .....10

6 Procedure .....10

6.1 Pull out test .....10

6.2 Determination of dry density and compressive strength of AAC.....11

7 Evaluation of test results .....11

7.1 Elimination of bond between longitudinal steel bar and AAC .....11

7.2 Calculation of bearing stress of the transverse bar.....11

8 Test report .....12

Bibliography .....13

**Figures**

Figure 1 — Example for cutting scheme ..... 6

Figure 2 — Test specimen type A (without transverse bar) and test arrangement ..... 7

Figure 3 — Test specimen type B and test arrangement ..... 8

Figure 4 — Test specimen type C and test arrangement ..... 9

Licensed copy: Lee Shau Kee Library, HKUST, Version correct as of 03/01/2015, (c) The British Standards Institution 2013

## Foreword

This document (EN 15361:2007) has been prepared by Technical Committee CEN/TC 177 “Prefabricated reinforced components of autoclaved aerated concrete or light-weight aggregate concrete with open structure”, the secretariat of which is held by DIN.

This European Standard shall be given the status of a national standard, either by publication of an identical text or by endorsement, at the latest by October 2007, and conflicting national standards shall be withdrawn at the latest by October 2007.

According to the CEN/CENELEC Internal Regulations, the national standards organizations of the following countries are bound to implement this European Standard : Austria, Belgium, Bulgaria, Cyprus, Czech Republic, Denmark, Estonia, Finland, France, Germany, Greece, Hungary, Iceland, Ireland, Italy, Latvia, Lithuania, Luxembourg, Malta, Netherlands, Norway, Poland, Portugal, Romania, Slovakia, Slovenia, Spain, Sweden, Switzerland and United Kingdom.

## 1 Scope

This document specifies a pull-out test method for the verification of the applicability of the declared outer diameter of the transverse bars with corrosion protection coating  $\phi_{ot,g}$  in the calculation of the anchorage capacity of transverse anchorage bars (see A.10.3 in prEN 12602:2006) in prefabricated reinforced components of autoclaved aerated concrete (AAC).

## 2 Normative references

The following referenced documents are indispensable for the application of this document. For dated references, only the edition cited applies. For undated references, the latest edition of the referenced document (including any amendments) applies.

EN 678, *Determination of the dry density of autoclaved aerated concrete*

EN 679, *Determination of the compressive strength of autoclaved aerated concrete*

## 3 Principle

Pull-out tests on prismatic AAC test specimens including a longitudinal bar with a welded transverse anchorage bar with corrosion protection coating (see 5.3, type C) are made. The bearing stress in front of the welded transverse anchorage bar is calculated using the measured mean outer diameter  $\phi_{ot,m}$  of the welded transverse bar including the coating.

For comparison, pull-out tests are made on otherwise alike test specimens, where the welded transverse bar is without corrosion protection coating, but has been treated with a thin layer of coating for elimination of bond (see 5.3 Type B). In this case the bearing stress in front of the transverse anchorage bar is calculated using the diameter of the transverse bar  $\phi$  (without coating).

In both cases the bond between the longitudinal bar and the AAC is eliminated using a proper method.

NOTE Comparison of the determined bearing stresses will show if it is applicable to use the declared effective outer diameter of the transverse bar with corrosion protection coating,  $\phi_{ot,g}$ , in the calculation of the anchorage capacity of the transverse anchorage bars.

## 4 Apparatus

- a) saw for cutting test specimens from reinforced AAC components without excessive heating, vibration or shock;
- b) testing machine or a loading device capable of applying a tension force at the required steady rate without shock and with an accuracy of 2 % of the ultimate pull-out force;
- c) rigid steel base plate with a central hole of 20 mm diameter to accommodate for the protruding longitudinal bar of the test specimen;
- d) intermediate layer of soft fibre board (thickness 10 mm to 20 mm, density 250 kg/m<sup>3</sup> to 300 kg/m<sup>3</sup>, with a central hole of 20 mm diameter, to be inserted between the test specimen and the rigid steel plate;
- e) device for measuring the slip between the longitudinal reinforcing bar and the AAC to an accuracy of 1/100 mm and for recording the load-slip curve;

- f) callipers capable of measuring the outer diameter of the transverse bar and the corrosion protection coating to an accuracy of 0,1 mm;
- g) ventilated drying oven, capable of maintaining a temperature of  $(105 \pm 5)$  °C;
- h) balance for weighing test specimens to an accuracy of 0,1 %.

## 5 Test specimens

### 5.1 General

The test specimens are obtained by cutting them e.g. from specially reinforced AAC components with a saw so that the longitudinal bar is in the middle of a 200 mm × 200 mm AAC cross-section. The transverse bars (short sections of 60 mm length welded in centre to the longitudinal bar) shall be located in a distance of approximately 200 mm from the supported surface of the test specimen.

### 5.2 Measurement of the mean outer diameter of the transverse bar with the corrosion protection coating

The outer diameter of the coated transverse bar shall be measured before the reinforcement is embedded in AAC. The measurement shall be performed by means of callipers at least at 6 different places of the coated transverse bar in perpendicular direction to the longitudinal bar. The mean value of the individual measurements  $\phi_{\text{tot,m}}$  shall be determined.

### 5.3 Shape, size and preparation of test specimens

Three types of AAC test specimens with the dimensions of 200 mm × 200 mm × 250 mm are prepared:

**Type A.** Three test specimens including a  $\phi$  (7 ± 0,5) mm longitudinal steel bar where bond between steel and AAC is eliminated using the same method as in type C test specimens, see Figure 2. They are for the verification that the bond has been adequately eliminated between the longitudinal bar and the AAC.

NOTE Tests made with type A test specimens (i.e. verification of the elimination of bond) are not necessary if previous tests have shown that the method used for the elimination of bond is reliable.

**Type B.** Three test specimens including a  $\phi$  (7 ± 0,5) mm longitudinal steel bar where bond between steel and AAC is eliminated using the same method as in type C test specimens and a  $\phi$  (7 ± 0,5) mm transverse bar (length  $L = 60$  mm) with thin layer coating for the elimination of bond, see Figure 3.

**Type C.** Three test specimens including a  $\phi$  (7 ± 0,5) mm longitudinal steel bar where bond between steel and AAC is eliminated using proper method and a  $\phi$  (7 ± 0,5) mm transverse bar (length  $L = 60$  mm) with the coating under consideration, see Figure 4.

Furthermore, 3 reference specimens shall be prepared with the same dimensions and the same reinforcement as the test specimens Type C. They shall be dried to constant mass at  $(105 \pm 5)$  °C, and their oven-dry mass  $m_{\text{d,ref}}$  shall be determined.

From each type one test specimen shall be prepared from the upper third of the component, one from the middle and one from the lower third, in the direction of rise of the mass during manufacture (see Figure 1).

NOTE The value  $m_{\text{d,ref}}$  is needed for the calculation of the required humid mass of the test specimens after conditioning according to NOTE 2 in 5.4.

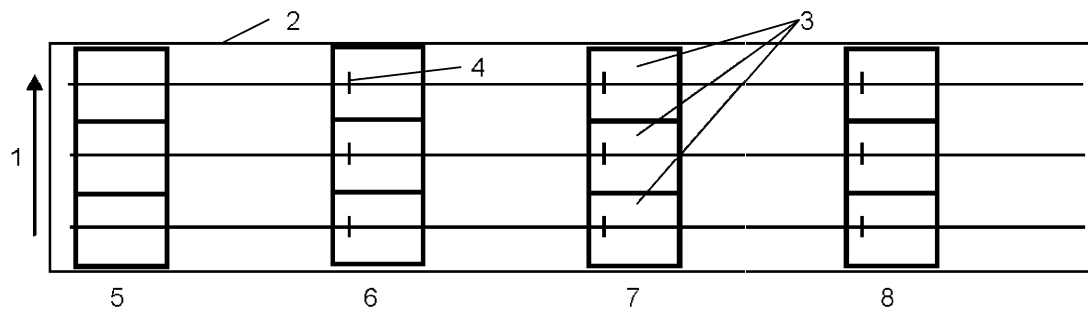

**Key**

- 1 direction of rise of mass during manufacture
- 2 specially reinforced prefabricated AAC-component
- 3 test specimens with central longitudinal bar  $\phi (7 \pm 0,5)$  mm
- 4 welded transverse bar,  $\phi (7 \pm 0,5)$  mm, length  $L = 60$  mm
- 5 test specimens Type A
- 6 test specimens Type B
- 7 test specimens Type C
- 8 reference specimens

**Figure 1 — Example for cutting scheme**

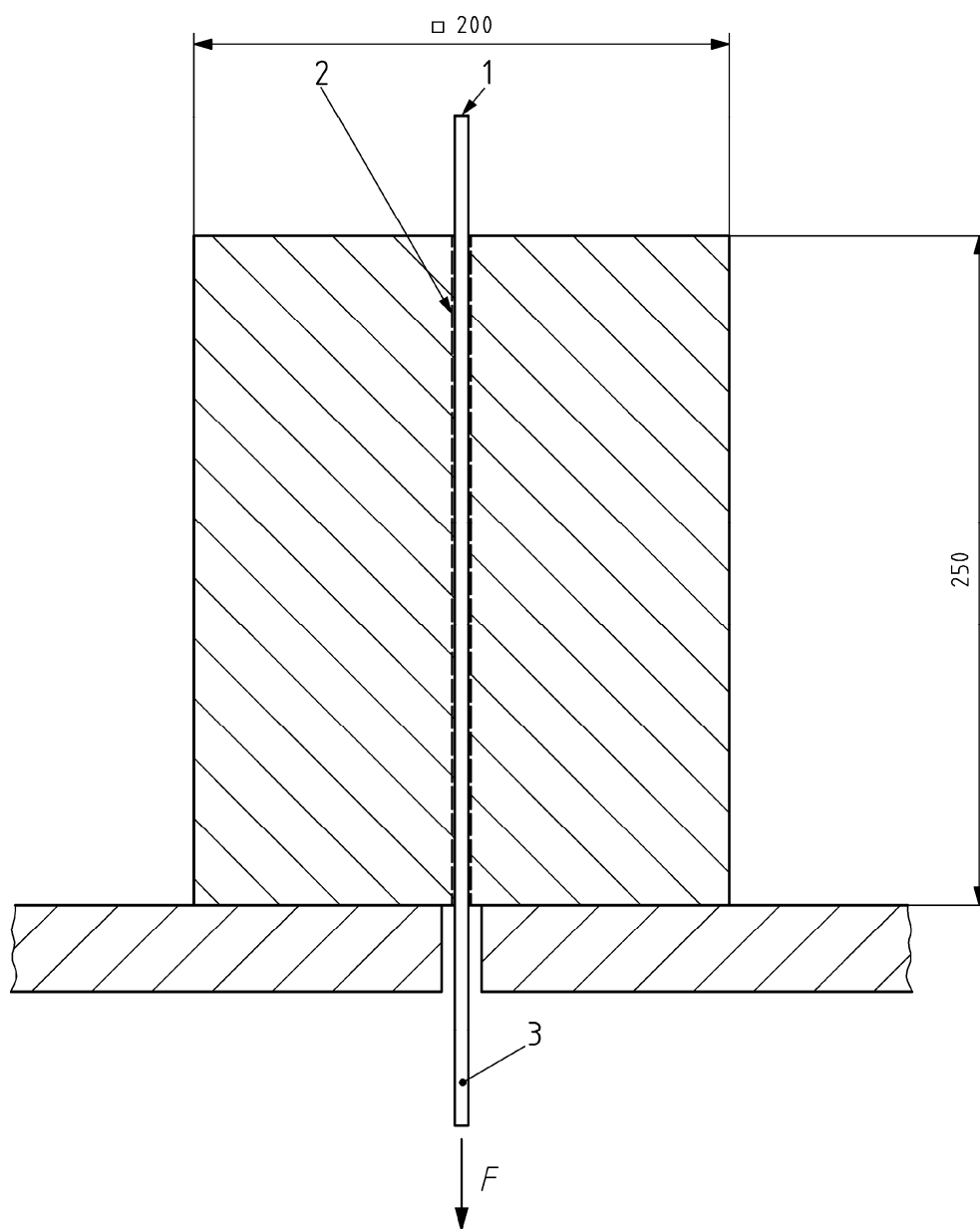

Dimensions in millimetres

**Key**

- $F$  pull-out force
- 1 measurement of displacement
- 2 bond is eliminated
- 3 longitudinal bar  $\phi$  7 mm in the middle

**Figure 2 — Test specimen type A (without transverse bar) and test arrangement**

Dimensions in millimetres

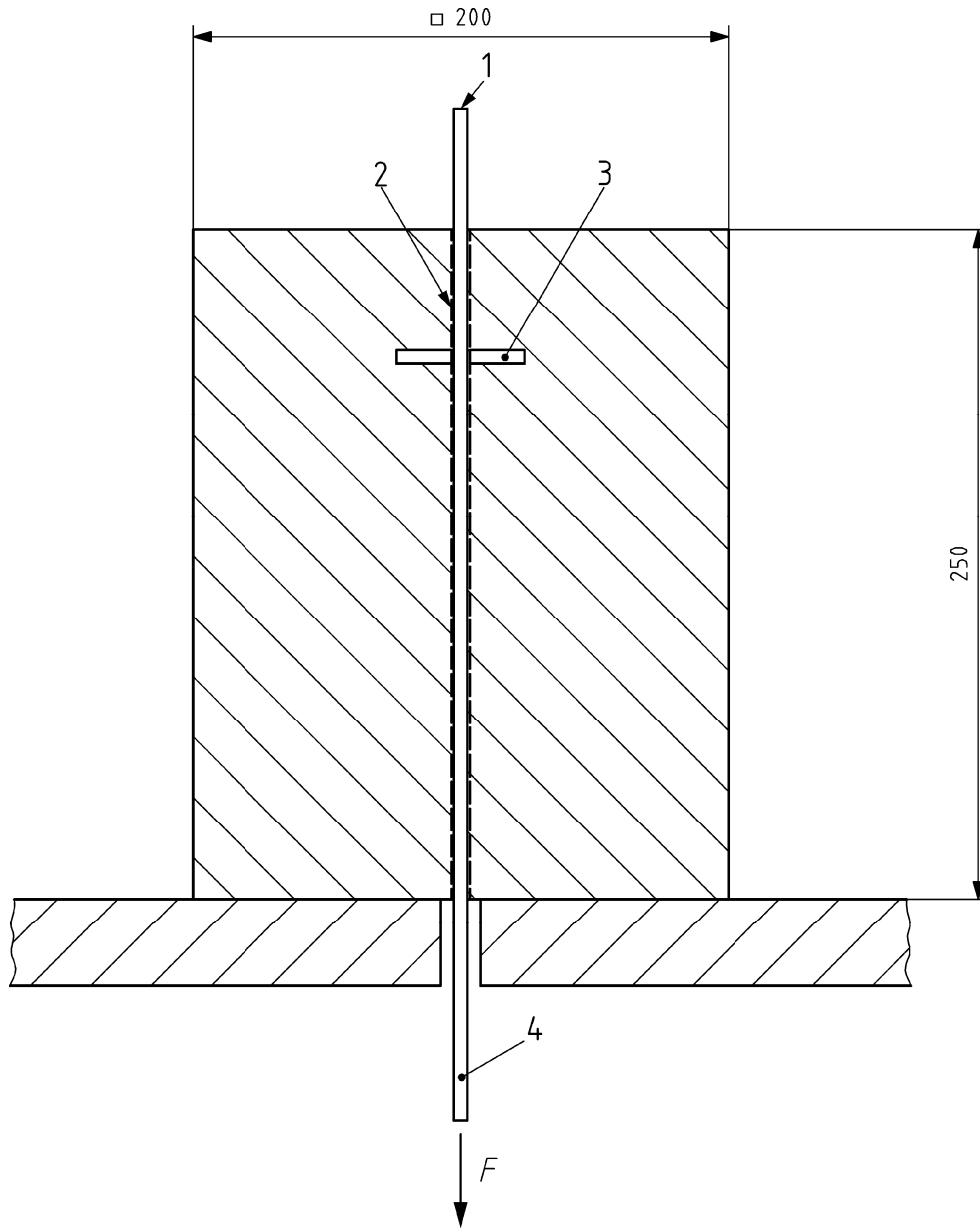

**Key**

- $F$  pull-out force
- 1 measurement of displacement
- 2 bond is eliminated
- 3  $\phi 7$  mm welded transverse bar,  $L = 60$  mm and thin layer coating for the elimination of bond
- 4  $\phi 7$  mm longitudinal bar in the middle

**Figure 3 — Test specimen type B and test arrangement**

Dimensions in millimetres

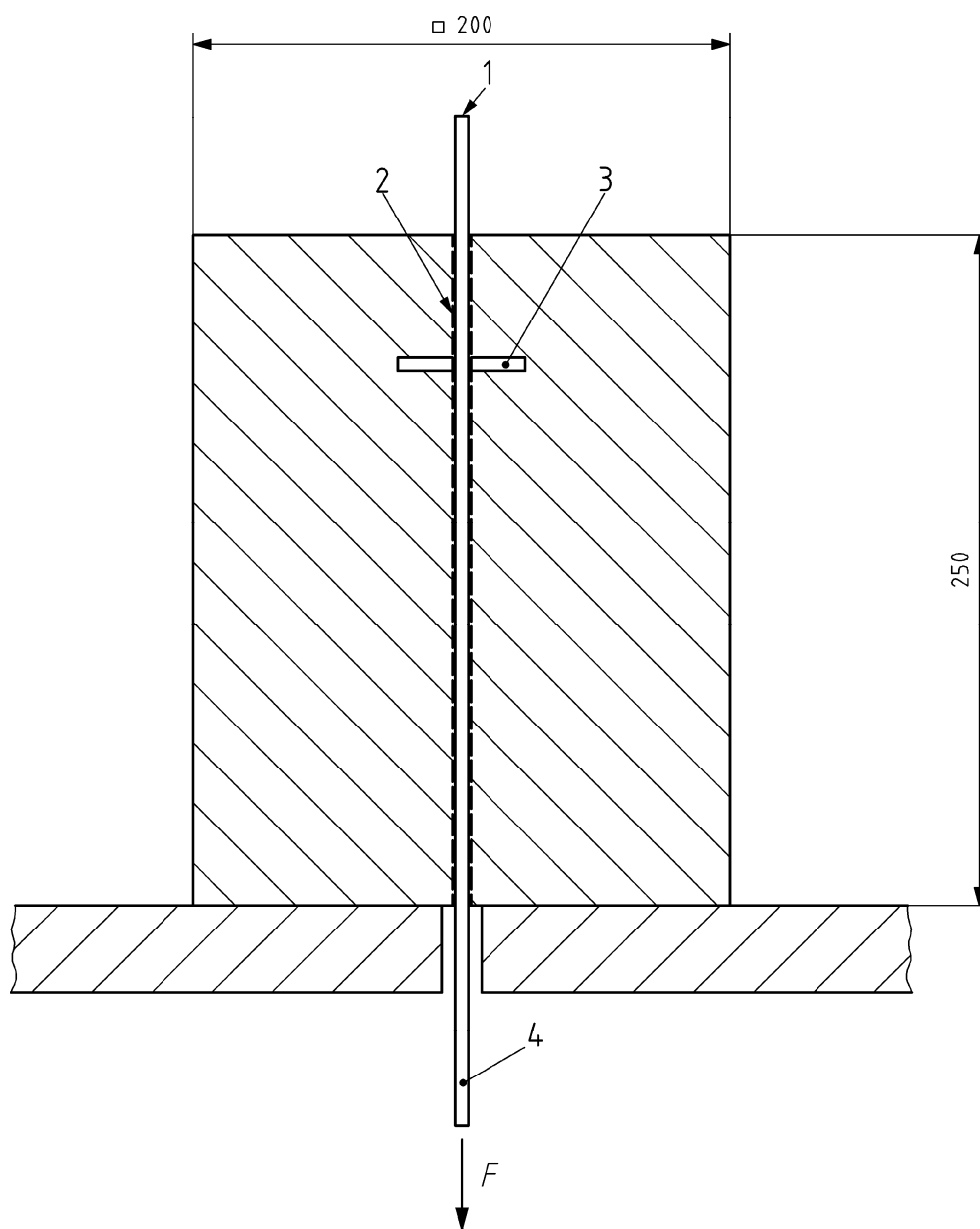
**Key**

- $F$  pull-out force
- 1 measurement of displacement
- 2 bond is eliminated
- 3  $\phi$  7 mm welded transverse bar,  $L = 60$  mm and corrosion protection under consideration
- 4  $\phi$  7 mm longitudinal bar in the middle

**Figure 4 — Test specimen type C and test arrangement**

## 5.4 Conditioning of test specimens

The test specimens shall be stored in such a manner that, when tested, they have a temperature of  $(20 \pm 5) ^\circ\text{C}$  (see NOTE 1) and a moisture content of  $(6 \pm 2) \%$  by mass (see NOTE 2).

If necessary, the test specimens shall be dried or moistened until their mass lies within the calculated limits (see NOTE 2). Subsequently they shall be stored prior to testing for at least 3 d in plastic bags or similar sealing to achieve a sufficiently uniform moisture distribution within the AAC.

The actual moisture content shall be verified by determining the mass of the test specimens in the humid state immediately before the test and after drying at  $(105 \pm 5) ^\circ\text{C}$  until constant mass has been obtained. The error in determining the mass shall not exceed 0,1 % of the mass of the test specimen. The mass of the test specimen is considered constant if after 24 h of further drying it has not changed by more than 0,2 %.

The moisture content  $\mu'_m$  is calculated as follows:

$$\mu'_m = 100 (m_h - m_d) / (m_d - m'_s) \quad (1)$$

where

$\mu'_m$  is the moisture content, in % by mass;

$m_h$  is the mass of the test specimen in the humid state, in kg;

$m_d$  is the mass of the dried test specimen immediately after removal from the drying oven, in kg;

$m'_s$  is the mass of the steel reinforcement contained in the test specimen, in kg.

NOTE 1 Other temperature may be chosen in special cases. This needs to be indicated in the test report.

NOTE 2 In order to achieve the prescribed moisture content within the test specimens the following procedure is recommended: The required humid mass of the test specimen is calculated using the following equation:

$$m_{h,r} = m_{d,ref} (1 + \mu'_m / 100) - (m''_s \cdot \mu''_m / 100) \quad (2)$$

where

$m_{h,r}$  is the required mass of the test specimen in the humid state, in kg;

$m_{d,ref}$  is the dry mass of the reference specimen with the same dimensions and the same reinforcement taken from the same component, the dry mass, in kilograms, being determined according to the last paragraph of 5.2;

$m''_s$  is the mass of the reinforcement, determined either by weighing or by calculation from the dimensions of the reinforcing bars and the density of steel ( $7\,850 \text{ kg/m}^3$ ), in kg;

$\mu''_m$  is the prescribed moisture content, in % by mass ( $(6 \pm 2) \%$  by mass).

## 6 Procedure

### 6.1 Pull out test

A suggested testing arrangement is shown in Figures 2, 3 and 4.

The test specimen is placed on the base steel plate so that the protruding longitudinal bar at the bottom of the test specimen goes through the hole in the base plate. The tension force shall be applied on the longitudinal bar.

During loading the displacement shall be measured continuously from the protruding longitudinal bar at the top of the test specimen.

The load shall be applied at a uniform rate so that the displacement does not exceed 0,5 mm/min. The load shall be increased until the displacement is at least 5 mm.

The load-displacement curve shall be recorded.

## 6.2 Determination of dry density and compressive strength of AAC

The dry density and the compressive strength of AAC shall be determined from the tested test specimens (types B and C) according EN 678 and EN 679 using small cubes.

## 7 Evaluation of test results

### 7.1 Elimination of bond between longitudinal steel bar and AAC

Load-displacement curves of type A test specimens shall be compared with the corresponding curves of type B and C test specimens. Bond is adequately eliminated if the force in the load-displacement curves of type A test specimens is much smaller.

### 7.2 Calculation of bearing stress of the transverse bar

From the load-displacement curves of type B and C test specimens the force at a displacement of 1 mm is recorded for each test specimen. For type B test specimens the mean value of the force  $F_{1m,B}$  is calculated and for type C test specimens the mean value of the force  $F_{1m,C}$  is calculated.

For type B test specimens the bearing stress of the transverse bar  $f_{cb,B}$  is calculated as follows:

$$f_{cb,B} = F_{1m,B} / (\phi_t \cdot L) \quad (3)$$

For type C test specimens the bearing stress of the coated transverse bar  $f_{cb,C}$  is calculated as follows:

$$f_{cb,C} = F_{1m,C} / (\phi_{tot,m} \cdot L) \quad (4)$$

The influence of the corrosion protection coating on the anchorage capacity of the transverse anchorage bar expressed as bearing stress of the transverse bar,  $f_{cb,C-B}$ , is calculated as follows:

$$f_{cb,C-B} = (F_{1m,C} - F_{1m,B}) / (\phi_t \cdot L) \quad (5)$$

where

$F_{1m,B}$  is the mean value of the force at displacement of 1 mm for type B test specimens;

$F_{1m,C}$  is the mean value of the force at displacement of 1 mm for type C test specimens;

$\phi_t$  is the diameter of the uncoated transverse bar;

$\phi_{tot,m}$  is the measured mean outer diameter of the coated transverse bar;

$L$  is the length of the transverse bar.

NOTE A displacement other than 1 mm in the load-displacement curve may be chosen in special cases. This needs to be indicated in the test report.

## 8 Test report

The test report shall include the following:

- a) identification of the product;
- b) date of manufacture or other code;
- c) place and date of testing, testing institute and person responsible for testing;
- d) number and date of issue of this European Standard, i.e. EN 15361:2007;
- e) dry density and compressive strength of type B and C test specimens;
- f) type of corrosion protection under consideration and type of thin layer coating;
- g) diameter of longitudinal bar and transverse bar;
- h) measured individual outer diameters of the transverse bar and corrosion protection coating and mean outer diameter of the transverse bar and corrosion protection coating,  $\phi_{\text{tot,m}}$ ;
- i) declared outer diameter of the transverse bar and corrosion protection coating,  $\phi_{\text{tot,g}}$ ;
- j) load-displacement curves of individual type A test specimens;
- k) statement if bond between longitudinal bar and AAC has been adequately eliminated;
- l) load-displacement curves of individual type B and C test specimens;
- m) mean value of the force at displacement of 1 mm for type B test specimens,  $F_{1\text{m,B}}$ ;
- n) mean value of the force at displacement of 1 mm for type C test specimens,  $F_{1\text{m,C}}$ ;
- o) bearing stress of the transverse bar for type B test specimens,  $f_{\text{cb,B}}$ ;
- p) bearing stress of the coated transverse bar for type C test specimens,  $f_{\text{cb,C}}$ ;
- q) influence of the corrosion protection on the anchorage capacity of the transverse anchorage bar expressed as bearing stress of the transverse bar,  $f_{\text{cb,C-B}}$ .

## Bibliography

- [1] prEN 12602:2006, *Prefabricated reinforced components of autoclaved aerated concrete*

---

---

## BSI — British Standards Institution

BSI is the independent national body responsible for preparing British Standards. It presents the UK view on standards in Europe and at the international level. It is incorporated by Royal Charter.

### Revisions

British Standards are updated by amendment or revision. Users of British Standards should make sure that they possess the latest amendments or editions.

It is the constant aim of BSI to improve the quality of our products and services. We would be grateful if anyone finding an inaccuracy or ambiguity while using this British Standard would inform the Secretary of the technical committee responsible, the identity of which can be found on the inside front cover.  
Tel: +44 (0)20 8996 9000. Fax: +44 (0)20 8996 7400.

BSI offers members an individual updating service called PLUS which ensures that subscribers automatically receive the latest editions of standards.

### Buying standards

Orders for all BSI, international and foreign standards publications should be addressed to Customer Services. Tel: +44 (0)20 8996 9001.  
Fax: +44 (0)20 8996 7001. Email: [orders@bsi-global.com](mailto:orders@bsi-global.com). Standards are also available from the BSI website at <http://www.bsi-global.com>.

In response to orders for international standards, it is BSI policy to supply the BSI implementation of those that have been published as British Standards, unless otherwise requested.

### Information on standards

BSI provides a wide range of information on national, European and international standards through its Library and its Technical Help to Exporters Service. Various BSI electronic information services are also available which give details on all its products and services. Contact the Information Centre.  
Tel: +44 (0)20 8996 7111. Fax: +44 (0)20 8996 7048. Email: [info@bsi-global.com](mailto:info@bsi-global.com).

Subscribing members of BSI are kept up to date with standards developments and receive substantial discounts on the purchase price of standards. For details of these and other benefits contact Membership Administration.  
Tel: +44 (0)20 8996 7002. Fax: +44 (0)20 8996 7001.  
Email: [membership@bsi-global.com](mailto:membership@bsi-global.com).

Information regarding online access to British Standards via British Standards Online can be found at <http://www.bsi-global.com/bsonline>.

Further information about BSI is available on the BSI website at <http://www.bsi-global.com>.

### Copyright

Copyright subsists in all BSI publications. BSI also holds the copyright, in the UK, of the publications of the international standardization bodies. Except as permitted under the Copyright, Designs and Patents Act 1988 no extract may be reproduced, stored in a retrieval system or transmitted in any form or by any means – electronic, photocopying, recording or otherwise – without prior written permission from BSI.

This does not preclude the free use, in the course of implementing the standard, of necessary details such as symbols, and size, type or grade designations. If these details are to be used for any other purpose than implementation then the prior written permission of BSI must be obtained.

Details and advice can be obtained from the Copyright & Licensing Manager.  
Tel: +44 (0)20 8996 7070. Fax: +44 (0)20 8996 7553.  
Email: [copyright@bsi-global.com](mailto:copyright@bsi-global.com).