

Slow heat release appliances fired by solid fuel — Requirements and test methods

The European Standard EN 15250:2007 has the status of a
British Standard

ICS 97.100.30

National foreword

This British Standard was published by BSI. It is the UK implementation of EN 15250:2007.

The UK participation in its preparation was entrusted to Technical Committee RHE/28, Domestic solid mineral fuel appliances.

A list of organizations represented on RHE/28 can be obtained on request to its secretary.

EN 15250 is a candidate “harmonized” European standard and fully takes into account the requirements of the European Commission mandate M/129 “Space heating appliances”, given under the EU Construction Products Directive (89/106/EEC), and intended to lead to CE marking. The date of applicability of EN 15250 as a harmonized European standard, i.e. the date after which this standard may be used for CE marking purposes, is subject to an announcement in the *Official Journal of the European Communities*. The Commission in consultation with Member States has agreed a transition period for the co-existence of harmonized European Standards and their corresponding national standard(s). It is intended that this period will comprise a period, usually nine months, after the date of availability of the European Standard, during which any required changes to national regulations are to be made, followed by a further period, usually of 12 months, for the implementation of CE marking. At the end of this co-existence period, the national standard(s) will be withdrawn. In the UK, there are no corresponding national standards.

This publication does not purport to include all the necessary provisions of a contract. Users are responsible for its correct application.

Compliance with a British Standard cannot confer immunity from legal obligations.

This British Standard was published under the authority of the Standards Policy and Strategy Committee on 30 April 2007

© BSI 2007

ISBN 978 0 580 50484 6

Amendments issued since publication

Amd. No.	Date	Comments

ICS 97.100.30

English Version

Slow heat release appliances fired by solid fuel - Requirements and test methods

Appareils de chauffage domestique à combustible solide à libération lente de chaleur - Exigences et méthodes d'essai

Speicherfeuerstätten für feste Brennstoffe - Anforderungen und Prüfverfahren

This European Standard was approved by CEN on 13 January 2007.

CEN members are bound to comply with the CEN/CENELEC Internal Regulations which stipulate the conditions for giving this European Standard the status of a national standard without any alteration. Up-to-date lists and bibliographical references concerning such national standards may be obtained on application to the CEN Management Centre or to any CEN member.

This European Standard exists in three official versions (English, French, German). A version in any other language made by translation under the responsibility of a CEN member into its own language and notified to the CEN Management Centre has the same status as the official versions.

CEN members are the national standards bodies of Austria, Belgium, Bulgaria, Cyprus, Czech Republic, Denmark, Estonia, Finland, France, Germany, Greece, Hungary, Iceland, Ireland, Italy, Latvia, Lithuania, Luxembourg, Malta, Netherlands, Norway, Poland, Portugal, Romania, Slovakia, Slovenia, Spain, Sweden, Switzerland and United Kingdom.



EUROPEAN COMMITTEE FOR STANDARDIZATION
COMITÉ EUROPÉEN DE NORMALISATION
EUROPÄISCHES KOMITEE FÜR NORMUNG

Management Centre: rue de Stassart, 36 B-1050 Brussels

Contents

Page

Foreword	4
1 Scope	5
2 Normative references	5
3 Terms and definitions	6
4 Materials, design and construction	9
4.1 Production documentation	9
4.2 Construction	10
4.2.1 General construction.....	10
4.2.2 Cleaning of heating surfaces	10
4.2.3 Flue spigot or socket.....	10
4.2.4 Flueways.....	10
4.2.5 Ashpan and ash removal	11
4.2.6 Bottomgrate	11
4.2.7 Combustion air supply.....	11
4.2.8 Control of flue gas	11
4.2.9 Firedoors and charging doors	12
4.2.10 Flue bypass device.....	12
4.2.11 Front firebars and/or deepening plate.....	12
5 Safety	12
5.1 Temperature rise in the fuel storage container	12
5.2 Temperature rise of the operating components.....	12
5.3 Temperature of adjacent combustible materials.....	12
5.4 Electrical safety	13
6 Performance	13
6.1 Flue gas temperature	13
6.2 Carbon monoxide emission	13
6.3 Efficiency.....	13
6.4 Flue draught	13
6.5 Refuelling intervals.....	13
6.6 Thermal storage capacity	13
7 Appliance instructions	14
7.1 General	14
7.2 Installation instructions	14
7.3 User operating instructions.....	15
8 Marking	16
9 Evaluation of conformity	16
9.1 General	16
9.2 Type testing.....	17
9.2.1 Initial type testing	17
9.2.2 Further type testing	18
9.3 Factory production control (FPC)	20
9.3.1 General	20
9.3.2 Raw materials and components.....	20
9.3.3 Control of inspection, measuring and test equipment.....	20
9.3.4 Process control.....	20
9.3.5 Product inspection, testing and evaluation	21
9.3.6 Non conforming products	22
9.3.7 Corrective and preventive action.....	22
9.3.8 Handling, storage, packaging, preservation and delivery.....	22

Annex A (normative) Test methods	23
A.1 Test environment	23
A.1.1 Ambient room temperature	23
A.1.2 Cross-draught	23
A.1.3 External sources	23
A.2 Test assembly	23
A.2.1 General	23
A.2.2 Trihedron	24
A.2.3 Measurement section	24
A.2.4 Connection of appliance to measurement section	25
A.2.5 Measurement of appliance surface temperature for slow heat release appliances	25
A.3 Measurement equipment	26
A.4 Test procedures	27
A.4.1 Appliance installation	27
A.4.2 Fuel load	27
A.4.3 Fuelling and de-ashing the fire	28
A.4.4 Flue gas losses	28
A.4.5 Combustible heat losses in the residue	28
A.4.6 Burning rate performance test	28
A.4.7 Temperature safety test for woodburning and multifuel appliances	29
A.5 Test results	30
A.6 Calculation methods	31
A.6.1 Notations and units used	31
A.6.2 Equations	32
A.7 Test report	36
Annex B (normative) Test fuels and recommended fuels	47
B.1 General	47
B.2 Test fuel	47
B.2.1 Selection of test fuel	47
B.2.2 Storage, preparation and analysis	47
B.3 Tests for recommended fuels	48
B.3.1 Basis of testing	48
B.3.2 Test methods and criteria	48
Annex C (informative) Calculation of an approximate heat release curve against time	54
Annex ZA (informative) Clauses of this European standard addressing the provisions of the EU Construction Products Directive	57
ZA.1 Scope and relevant characteristics	57
ZA.2 Procedure for the attestation of conformity of slow heat release appliances fired by solid fuels	59
ZA.2.1 System of attestation of conformity	59
ZA.2.2 EC Declaration of conformity	60
ZA.3 CE Marking and labelling	60
Bibliography	63

Foreword

This document (EN 15250:2007) has been prepared by Technical Committee CEN/TC 295 "Residential solid fuel burning appliances", the secretariat of which is held by BSI.

This European Standard shall be given the status of a national standard, either by publication of an identical text or by endorsement, at the latest by September 2007, and conflicting national standards shall be withdrawn at the latest by September 2007.

This document has been prepared under a mandate given to CEN by the European Commission and the European Free Trade Association, and supports essential requirements of EU Directive(s).

For relationship with EU Directive(s), see informative Annex ZA, which is an integral part of this document.

According to the CEN/CENELEC Internal Regulations, the national standards organizations of the following countries are bound to implement this European Standard: Austria, Belgium, Bulgaria, Cyprus, Czech Republic, Denmark, Estonia, Finland, France, Germany, Greece, Hungary, Iceland, Ireland, Italy, Latvia, Lithuania, Luxembourg, Malta, Netherlands, Norway, Poland, Portugal, Romania, Slovakia, Slovenia, Spain, Sweden, Switzerland and United Kingdom.

1 Scope

This European Standard specifies requirements relating to the design, manufacture, construction, safety and performance (efficiency and emission) instructions and marking together with associated test methods and test fuels for type testing residential slow heat release appliances fired by solid fuel.

This European Standard is applicable to hand fuelled intermittent burning slow heat release appliances having thermal storage capacity such that they can provide heat for a declared period of time after the fire has gone out. This European Standard also specifies a minimum time period from the appliance achieving the maximum differential surface temperature and falling to 50 % of that maximum value. These appliances provide heat into the space where they are installed.

These slow heat release appliances may be supplied either as an assembled appliance or as a manufacturer's pre-designed unit consisting of pre-fabricated components designed to be built on site in accordance with the manufacturer's specified assembly instructions. One off installations are not included.

These appliances may burn either solid mineral fuels, peat briquettes, natural or manufactured wood logs or be multi-fuel in accordance with the appliance manufacturer's instructions. Wood pellets which are hand fuelled may also be burned either on the existing appliance bottomgrate or in a special basket arrangement which is placed by the user into the existing firebox.

This European Standard is not applicable to mechanically fed appliances, appliances having fan assisted combustion air or appliances with boiler.

2 Normative references

The following referenced documents are indispensable for the application of this document. For dated references, only the edition cited applies. For undated references, the latest edition of the referenced document (including any amendments) applies.

EN 50165:1997, *Electrical equipment for non-electric appliances for household and similar purposes — Safety requirements*

ISO 334:1992, *Solid mineral fuels — Determination of total sulfur — Eschka method*

ISO 351:1996, *Solid mineral fuels — Determination of total sulfur — High temperature combustion method*

ISO 501:2003, *Hard coal — Determination of the crucible swelling number*

ISO 562:1998, *Hard coal and coke — Determination of volatile matter*

ISO 609:1996, *Solid mineral fuels — Determination of carbon and hydrogen — High temperature combustion method*

ISO 687:2004, *Solid mineral fuels — Coke — Determination of moisture in the general analysis test sample*

ISO 1171:1997, *Solid mineral fuels — Determination of ash*

ISO 1928:1995, *Solid mineral fuels — Determination of gross calorific value by the bomb calorimetric method, and calculation of net calorific value*

ISO 2859 (all parts), *Sampling procedures for inspection by attributes*

ISO 11722:1999, *Hard coal — Determination of moisture in the general analysis test sample by drying in nitrogen*

3 Terms and definitions

For the purposes of this document, the following terms and definitions apply.

3.1

air grilles

components in the inlet and outlet openings to distribute and direct convection air flow

3.2

air inlet control

manual or automatic device which controls the quantity of air supplied for combustion

3.3

appliance family

group of appliances of similar construction and/or performance characteristics where it is permissible to test only selected appliances in accordance with the requirements of this standard

3.4

ash content of the fuel

solid matter remaining after the complete combustion of solid fuel

3.5

ashpan

removable receptacle shaped to receive the residue falling from the firebed

3.6

ashpit

enclosed chamber designed to receive the residue or the ashpan

3.7

ashpit loss

part of the residue which is combustible

3.8

basic firebed

quantity of glowing embers which ensures ignition of the test fuel to be charged

NOTE The basic firebed may be specified by the manufacturer.

3.9

batch charge

proportion of the test load as declared by the manufacturer that can be added at specified intervals during the test period of the burning rate performance test

3.10

bottomgrate

part of the appliance at the base of the firebox which supports the firebed through which the residue falls into the ashpan or ashpit and through which combustion air and/or combustion gases may be drawn

3.11

bottomgrate bars; firebars

bars supporting the fuelbed, separate or integral with a surrounding frame

3.12

charging door

door which covers the refuelling opening

3.13

combustion air

air supplied to the firebox which is entirely or partially used to burn the fuel

3.14**combustion gases**

compounds in gaseous form produced inside an appliance when fuel is burned

3.15**de-ashing**

process of clearing a fuelbed and discharging the residue into the collecting receptacle

3.16**de-ashing mechanism**

device to agitate or disturb the ash to facilitate its removal from the firebed

NOTE

It may also be used to change the bottomgrate operating position on some appliances.

3.17**draught regulator**

inlet device for admission of air downstream of the firebed, enabling the flue draught to be controlled

3.18**efficiency**

ratio of total heat output to the total heat input during the burning period expressed as a percentage

3.19**firebox; combustion chamber**

part of the appliance in which the fuel is burned

3.20**firebox opening**

aperture in the firebox through which an appliance may be fuelled

3.21**firedoor**

door through which the fire may be viewed and which may be opened to allow refuelling of the firebed

3.22**flue by-pass device**

device which in the open position allows flue gases to pass directly to the flue spigot/socket

NOTE

This can be used as a preheating aid to overcome chimney condensation.

3.23**flue damper**

mechanism to change the flow of the combustion gases

3.24**flue draught**

differential between the static pressure in the place of installation and the static pressure at the flue gas measurement point

3.25**flue gases**

gaseous compounds leaving the appliance flue spigot or socket and entering the flue gas connector

3.26**flue gas connector**

duct through which flue gases are conveyed from the flue spigot of the appliance into the chimney flue

3.27**flue gas mass flow**

mass of flue gas drawn off from the appliance per unit of time

3.28

flue gas temperature

temperature of the flue gas at the specified point in the measurement section

3.29

flue spigot; flue socket

integral part of the appliance for connecting the flue gas connector thus permitting the deliberate escape of products of combustion into the chimney flue

3.30

flueway

part of an appliance designed to convey combustion gases from the firebox to the flue spigot/socket

3.31

front firebars

grating or plate fitted at the front of the firebox opening to prevent spillage of fuel and ash or to change the firebox capacity, or both

3.32

integral fuel storage container

enclosed area forming part of the appliance, but not connected directly to the fuel charging area, in which fuel is stored prior to it being physically transferred by the user to the fuel charging

3.33

total heat input

position quantity of energy which the fuel provides to the appliance during

3.34

operating tool

device supplied with the appliance for handling movable and/or hot components

3.35

primary air

combustion air which passes through the fuel bed

3.36

recommended fuel

fuel of commercial quality, listed in the appliance manufacturer's instructions, and shown to achieve the claimed performance when tested in accordance with this European Standard

3.37

residue

ashes, including combustibles, which collect in the ashpit

3.38

slow heat release appliance

intermittent burning appliance having thermal storage capacity to accumulate heat into its mass such that it provides heat for a period of hours, specified by the manufacturer, after the fire has gone out

3.39

solid fuel

naturally occurring or manufactured solid mineral fuels, natural or manufactured wood logs and peat briquettes

3.40

solid mineral fuel

coal, lignite, coke and fuels derived from these

3.41

space heating output

heat output provided as convection and radiation to the room

3.42**test fuel**

fuel of commercial quality being characteristic of its type to be used for testing appliances

3.43**test load**

mass of test fuel declared by the manufacturer for the burning rate performance test

NOTE The test load can be added as batch charges if the manufacturer indicates this in the appliance instructions.

3.44**total heat output**

total heat output of the appliance quoted by the manufacturer and achieved under defined test conditions when burning the specified test fuel and is calculated as the total heat input less the flue and unburned carbon losses

3.45**working surfaces**

all surfaces of an appliance designed to transmit heat to the surrounding atmosphere

NOTE All external surfaces of a slow heat release appliance including the flue gas connector in accordance with this European Standard are classified as working surfaces because they are designed to transmit heat into the room in which they are installed.

4 Materials, design and construction**4.1 Production documentation**

The manufacturer shall state the type of appliance, which he is submitting for test and the appliance shall be tested in accordance with the provisions of this European Standard and with the test methods as defined in Annex A.

The parameters and characteristics considered in making the decisions in relation to either the family or range of appliances to be submitted for initial type testing (see 9.2.1) or further type testing where changes are made to an appliance (see 9.2.2) shall be recorded. A copy of the parameters and characteristics considered in making the decisions shall be included in the production documentation for each appliance.

To identify the appliance, the manufacturer shall have available documents and/or scaled assembly drawings showing the basic design and construction of the appliance. The documentation and/or the drawings shall include at least the following information:

- the specification of the materials used in the construction of the appliance;
- the fuel loading mass and if applicable the number and mass of any batch charges;
- the time duration to firstly reach maximum mean surface temperature value, to secondly reach 50 % of that maximum value and finally to reach 25 % of that maximum value based upon differential surface temperatures against ambient temperatures;
- the total amount of heat energy stored in the appliance during the fuel burning period.

For appliances which are supplied as pre-designed units consisting of pre-fabricated components designed to be assembled on site then the manufacturer shall provide detailed assembly instructions for the construction of the appliance together with details of making a gas tight connection between the chimney, the appliance and the flue gas connector and for type testing the appliance shall be constructed and tested in accordance with these instructions.

4.2 Construction

4.2.1 General construction

The shape and dimensions of the components and equipment and the method of design and manufacture and if assembled on site the method of assembly and installation, shall ensure that when operated as specified in accordance with the test procedures of this European Standard and exposed to the associated mechanical, chemical and thermal stresses, the appliance shall operate reliably and safely such that during normal operation no combustion gas posing a hazard can escape into the room in which the appliance is installed nor can embers fall out. Non-combustible materials shall be used, except that it shall be permissible to use combustible materials for the following applications:

- components or accessories fitted outside the appliance;
- internal components of controls and safety equipment;
- operating handles;
- critical equipment.

No part of the appliance shall comprise any material known to be harmful.

When fired with solid mineral fuels, the appliance shall have a bottomgrate and an ashpan.

Component parts, which require periodic replacement and/or removal shall be either so designed or marked for identification to ensure correct fitting.

NOTE 1 Because the entire heat dissipating surfaces of the appliance including the flue spigot/socket and the flue gas connector are working surfaces, there is no requirement for limiting the surface temperature of the appliance.

NOTE 2 All operations which the user carries out, including loading and emptying of the appliance, adjusting controls and de-ashing should be easy, safe and effective.

4.2.2 Cleaning of heating surfaces

All heating surfaces shall be accessible from the flue gas side for inspection and cleaning with brushes, scrapers or chemical agents by means of sufficient cleaning openings.

4.2.3 Flue spigot or socket

The method of connection to enable a gas tight connection to be made between the chimney, the flue gas connector and the appliance shall be detailed in the appliance installation instructions.

For horizontal flue connection, the flue spigot/socket shall be designed to allow fitting, internal or external, over a length of at least 40 mm, of a flue gas connector.

For vertical flue connection, the fitting shall either overlap by at least 25 mm or be designed to enable a gas tight connection to be made between the chimney, the flue gas connector and the appliance.

4.2.4 Flueways

The size of the flueway in its minimum dimension shall be not less than 30 mm except for appliances designed to burn fuels other than bituminous coals when it shall be permissible to reduce it to not less than 15 mm provided easy access door(s) are provided for viewing and cleaning the whole of the flueways. It shall be possible to clean the flueways of the appliance completely using commercially available tools or brushes, unless special tools or brushes are provided by the appliance manufacturer.

4.2.5 Ashpan and ash removal

A means for the removal of the ash residue from the appliance shall be provided. When an ashpan is provided, it shall be capable of containing the combustion residue from two full charges of fuel whilst retaining sufficient space above to allow adequate primary air flow through the bottomgrate or firebed. If the ashpan resides in the appliance it shall locate in the ashpit in such a way that it allows the free passage of primary air and in such a position that it does not obstruct any primary air inlet control.

NOTE 1 The ashpan should be designed and constructed to ensure that:

- a) it effectively collects the residue from beneath the bottomgrate;
- b) it can be easily and safely withdrawn, carried and emptied when hot, using the tool(s) provide, without undue spillage of residue material;

NOTE 2 The ashpan can be shovel shaped.

4.2.6 Bottomgrate

Where the bottomgrate or pellet container is removable it shall be so designed or marked as to ensure correct fitting.

If a de-ashing mechanism is fitted it shall be capable of effectively de-ashing the fuelbed.

NOTE 1 The preferred design with the firedoor(s) and ashpit door(s) closed should allow de-ashing to be carried out. The de-ashing should be possible without undue effort.

NOTE 2 If it is necessary to remove the ashpit door to de-ash the fire, the appliance should be designed to minimise ash or fuel spillage during the de-ashing operation.

4.2.7 Combustion air supply

4.2.7.1 Primary air inlet control

The appliance shall be fitted with either a thermostatically controlled primary air inlet control or a manual primary air inlet control. The adjusting control shall be clearly visible and shall be permanently marked so that its operation is readily understandable.

The design shall be such that during operation of the appliance, neither ash nor unburned fuel can prevent the movement or closure of the air inlet control.

The 'cold' setting of the air inlet control shall be clearly marked and the method of adjustment shall be described in the user instructions.

The thermostat shall have a variable temperature range and be of the immersion or dry pocket type.

4.2.7.2 Secondary air inlet control

Where a secondary air inlet control is provided, the position of air entry shall be so designed that the passage of air is not restricted when the firebox is filled to the manufacturer's recommended capacity.

4.2.8 Control of flue gas

If a flue damper is fitted it shall be of a type, which does not block the flue totally. The damper shall be easy to operate and incorporate an aperture within the blade, which in a continuous area occupies at least 20 cm² or 3 % of the cross-sectional area of the blade if this is greater.

The position of the damper shall be recognizable from the setting of the device.

If a draught regulator is fitted the minimum cross sectional area requirement shall not be applicable but the device shall be easily accessible for cleaning.

4.2.9 Firedoors and charging doors

When the appliance is equipped with a charging door, that door shall be large enough to allow the appliance to be filled with the commercial fuels recommended by the manufacturer. Firedoors and charging doors shall be designed to prevent accidental opening and to facilitate positive closure.

4.2.10 Flue bypass device

Any flue bypass device shall be easily operable. The extreme positions corresponding to full opening and closing shall be easily and readily identifiable.

4.2.11 Front firebars and/or deepening plate

Front firebars shall be designed to retain the fuel or ash such that there is no undue spillage of ash or burning fuel from the slow heat release appliance during normal operations, particularly during refuelling or de-ashing.

If the appliance is fitted with removable front firebars and/or deepening plate, they shall be of a design such that they can neither be incorrectly fitted nor accidentally dislodged.

Solid mineral fuel and peat briquettes burning appliances

When the recommended fuels are solid mineral fuel and peat briquettes, the appliances shall have a bottomgrate and an ashpan.

5 Safety

5.1 Temperature rise in the fuel storage container

When tested in accordance with A.4.6 and A.4.7, the temperatures measured in the fuel storage container shall not exceed the ambient room temperature by more than 65 K.

5.2 Temperature rise of the operating components

If the manipulation of the operating components does not require the assistance of tools, the surface temperatures, measured only in the areas to be touched, shall not exceed the ambient room temperature by more than the following when tested in accordance with A.4.6:

- 35 K for metal;
- 45 K for porcelain, vitreous enamel or similar materials;
- 60 K for plastics, rubber or wood.

If these temperatures are exceeded, the manufacturer shall indicate in the instructions the need to use an operating tool. This tool shall be supplied with the appliance.

NOTE A suitable glove is regarded as a tool.

5.3 Temperature of adjacent combustible materials

When tested during the burning rate performance test in accordance with A.4.6, and the temperature safety test in accordance with A.4.7, and when the appliance is installed in accordance with the clearance distances specified in the manufacturer's installation instructions, the temperature of the test hearth and walls and/or ceiling or any other structure surrounding the appliance comprising combustible material shall not exceed the ambient room temperature by more than 65 K.

5.4 Electrical safety

The appliance shall comply with the electrical safety requirements of EN 50165 if mains operated electrical equipment is fitted as part of the appliance.

6 Performance

6.1 Flue gas temperature

When tested in accordance with A.4.6, the flue gas temperature shall be measured and the mean calculated and recorded in the installation instructions.

6.2 Carbon monoxide emission

When measured during the burning rate performance test in accordance with A.4.6, the mean carbon monoxide concentration calculated to 13 % oxygen (O₂) content in the flue gas shall be less than or equal to the manufacturer's declared value and shall not exceed 0,3 %.

Some countries have existing national legislation which set limits for maximum carbon monoxide concentration levels under nominal heat output and /or under slow or reduced combustion, in these cases the carbon monoxide level shall be measured during the burning rate performance test in accordance with A.4.6 for appliances sold in that country.

6.3 Efficiency

When tested during the burning rate performance test in accordance with A.4.6, the measured total efficiency from the mean of at least two test results shall be greater than or equal to the manufacturer's declared value and shall equal or exceed 70 %.

Some countries have existing national legislation which set limits for minimum efficiency under nominal heat output and/or slow or reduced combustion, in these cases the minimum efficiency shall be determined during the burning rate performance test in accordance with A.4.6 for appliances sold in that country.

6.4 Flue draught

When undertaking the burning rate performance test in accordance with A.4.6 the flue static pressure shall be kept within (12 ± 2) Pa. Where this flue draught value needs to be exceeded in order to obtain the manufacturer's declared burning rate, the required flue draught shall be clearly stated in the appliance's installation instructions. For the temperature safety test in accordance with A.4.7 the appliance shall be tested at a flue draught 3 Pa greater than that used during the burning rate performance test and the static pressure shall be kept within $^{+2}_0$ Pa of this specified value.

6.5 Refuelling intervals

The manufacturer shall state the mass of the fuel load and the refuelling interval(s) and/or the number and mass of batch charges which shall be used during the burning rate performance test in accordance with A.4.6. Any batch charge shall be not less than 20 % of the total fuel loading.

The slope formed by the test fuel load shall not obstruct, even partially, any flue.

6.6 Thermal storage capacity

The time period from the appliance achieving the maximum surface temperature and falling to 50 % of that maximum value based upon differential surface temperatures against ambient temperatures during the burning rate performance test in accordance with A.4.6 shall be not less than 4 h.

The manufacturer shall also declare the total amount of heat energy stored in the appliance during the fuel burning period which shall be confirmed when the appliance is operated in accordance with the manufacturer's operating instructions during the burning rate performance test detailed in A.4.6.

7 Appliance instructions

7.1 General

Instructions written in the language of the country of intended destination shall accompany the appliance and shall describe the installation, operation, maintenance and, if assembled on site, the assembly of the appliance. The instructions shall not be in contradiction to the requirements or test results in accordance with this European Standard.

7.2 Installation instructions

The installation instructions shall contain at least the following information:

- the words "any national or local regulations, and codes of practice, shall be complied with";
- the type (model or number) of the appliance;
- the safety clearances against combustible materials, and the other protective measures that shall be taken to protect the building construction;
- the requirements for the supply of combustion air, for the simultaneous operation with other appliances and for the operation of exhaust air devices;

NOTE Extractor fans when operating in the same room or space as the appliance, may cause problems.

- the need of any air inlet grilles to be so positioned that they are not liable to blockage;
- the mass of the appliance in kg;
- the minimum flue draught for the burning rate performance test;
- flue gas mass flow in g/s under the output conditions of the burning rate performance test;
- whether the appliance is suitable for installation in a shared flue system;
- the flue gas temperature directly downstream of the flue spigot/socket in °C, under the output conditions of the burning rate performance test;
- the floors: the appliance shall be installed on floors with an adequate load-bearing capacity. If an existing construction doesn't meet this prerequisite then suitable measures (e.g. load distributing plate) shall be taken to achieve it;
- the assembly of the appliance on-site, if applicable;
- advice on the need to provide access for cleaning the appliance, the flue gas connector and the chimney flue;
- the installation of the damper device, if applicable;
- the setting of temperature controller and method of adjusting the "cold" setting distance;
- the time duration to firstly reach maximum mean surface temperature value, to secondly reach 50 % of that maximum value and finally to reach 25 % of that maximum value based upon differential surface temperatures against ambient temperatures;

- the total amount of heat energy stored in the appliance during the fuel burning period;
- the method of connection between the chimney, the flue gas connector and the appliance to enable a gas tight connection to be ensured for slow heat release appliances having a vertical chimney connection;
- advice on the installation of any air grilles, especially in relation to the temperature of surrounding walls, floor, ceiling or other structure around the appliance;
- sealing of components to avoid leakage.

7.3 User operating instructions

Each appliance shall be accompanied by instructions in the language of the country in which it is to be operated, containing all important details regarding the operation for the concerned appliance.

The operating instructions shall contain at least the following information:

- national and local requirements on appliance operation and fuel (permissible fuels) to be met when operating the appliance in the specific country of destination;
- a list of the recommended fuels including type and size in accordance with this European Standard;
- details of the method of refuelling and de-ashing the appliance and the maximum filling height in the firebox and the fuel loading mass and if applicable the number and mass of batch charges for various recommended fuels;
- a description of the correct instructions for safe and efficient operation of the appliance including the ignition procedure;
- advice against the use of the appliance as an incinerator and the use of unsuitable and non recommended fuels, including advice against the use of liquid fuels;
- the operation of all adjusting devices, dampers and controls;
- ventilation requirements for simultaneous operation with other heating appliances (where applicable);
- the correct operations for seasonal use and under adverse flue draught or adverse weather conditions;
- advice on the need for regular maintenance by a competent engineer;
- a warning that the firebox and ashpit cover shall be kept closed except during ignition, refuelling and removal of residue material to prevent fume spillage;
- the need for regular cleaning of the appliance, of the flue gas connector and the chimney flue and highlighting the need to check for blockage prior to re-lighting after a prolonged shut down period;
- advice on the adequate provision of combustion and ventilation air and on keeping air intake grilles; supplying combustion air, free from blockage;
- instructions on simple fault finding and the procedure for the safe shut down of the appliance in event of malfunction e.g. overheating;
- warning that parts of the appliance, especially the external surfaces, will be hot to touch when in operation and due care will need to be taken;
- the means of protection against risk of fire in and outside the heat radiation area;
- warning against any unauthorised modification of the appliance;

EN 15250:2007 (E)

- use of only replacement parts recommended by the manufacturer;
- advice about the actions to be taken in the event of a chimney fire;
- whether the appliance is suitable for installation in a shared flue system;
- specific instructions on the use of the slow heat release appliance.

8 Marking

Each appliance shall be permanently and legibly marked, with the minimum following information, in a place where it is accessible so that the information can be read when the appliance is in its final location:

- the manufacturer's name or registered trade mark;
- the type or the model;
- the standard number, i.e. EN 15250;
- the instruction "follow the user's instructions";
- the minimum clearance distances from combustible materials, in mm, as appropriate;
- whether or not the appliance can be used in a shared flue;
- the words "use only recommended fuels";
- the time duration to firstly reach maximum mean surface temperature value, to secondly reach 50 % of that maximum value and finally to reach 25 % of that maximum value based upon differential surface temperature measurements against ambient temperature;
- the total amount of heat energy stored in the appliance during the fuel burning period;
- the fuel loading mass;
- the refuelling interval or the number and mass of batch charges as applicable;
- advice on the adjustment of any air grilles, where fitted;
- the measured CO concentration at 13 % oxygen content and the determined appliance efficiency as defined in 6.2 and 6.3 respectively.

If a label is used it shall be durable and abrasion proof. Under normal operating conditions, the label shall not discolour, thus making the information difficult to read. Self-adhesive labels shall not become detached as a result of moisture or temperature.

Where the marking required by ZA.3 gives some or all of the items detailed above, then they need not be repeated and the requirements of this clause in relation to those items are deemed to be met. Those items not covered by ZA.3 marking shall be given on the marking label.

9 Evaluation of conformity

9.1 General

The compliance of a slow heat release appliance with the requirements of this standard and with the stated values shall be demonstrated by:

- initial type testing;
- factory production control by the manufacturer, including product assessment.

For the purposes of testing, appliances may be grouped into families, where it is considered that the selected performance characteristic or characteristics, especially in respect of those detailed in Table 1 and Table 2, is/are common to all appliances within that family.

9.2 Type testing

9.2.1 Initial type testing

Initial type testing shall be performed to demonstrate conformity to this European Standard. In the case of an appliance already in production the appliance to be tested shall be chosen at random and be representative of general production and the manufacturer shall provide a written declaration to this effect.

In the case of a prototype the appliance tested shall be a model representative of the intended future production and the manufacturer shall provide a written declaration that this is the case. When the appliance goes into production a dimensional and constructional check shall be undertaken on the production appliance to confirm it is in agreement with the originally type tested prototype model. If the dimensions of the production appliance diverge by more than $\pm 5\%$ on width and depth or $\pm 10\%$ on height from that of the prototype in relation to the firebox and/or combustion chamber and any other dimension considered to be critical to the safety or performance of the appliance (especially in respect of the characteristics of Table 1 and Table 2) or by $+5 -0\%$ on the width of flueways then the production appliance itself shall be subjected to further type testing as detailed in 9.2.2.

Similarly, if there is a change to the construction materials used which will adversely alter the performance characteristics of the appliance especially as regards its safety and/or the meeting of the performance characteristics of Table 2 then the production appliance itself shall be subject to further type testing as detailed in 9.2.2. This requirement regarding re-testing shall be applied if during the subsequent production or at the start of a new production run such a change is made to dimensions and/or construction materials. To ensure that this takes place there shall be a dimensional/constructional check on a current production appliance over an ongoing period not exceeding 3 years to demonstrate conformity to type.

Where tests have been previously performed in accordance with the provisions of this standard (same product, same characteristic(s), test method, sampling procedure, system of attestation of conformity etc.) then the results of these tests shall be taken into account in assessing continuing conformity to type.

For a family or range of appliance it shall be permissible to test only selected appliances across the family or range and to only verify selected constructional and performance characteristics on the others, subject to a clear decision being made that the appliances are part of a family or range of appliances. For the initial type test at least a sufficient number of the appliances shall be chosen from across the family or range so as to represent adequately the family or range. The chosen appliances shall be subjected to complete testing to fully verify their compliance with all of the constructional and performance characteristics in accordance with this European Standard. For the other appliances in the family or range not chosen for complete testing it shall be permissible to only verify selected constructional and/or performance characteristics to ensure their compliance with the requirements of this European Standard and/or to ensure they will perform the same as the fully type tested appliances of the family or range.

In selecting appliances for type testing from a product range based upon their total heat outputs as representing such a family then appliances having the lowest and highest claimed total heat outputs shall be tested together with sufficient appliances chosen from within the range that the ratio of total heat output between the appliances does not exceed the ratio of 1,6:1.

Further, in deciding that the appliances belong to a family or range due account shall be taken of the construction and performance characteristics of each appliance especially in respect of the list of characteristics detailed in Table 1 and Table 2. Where a range of appliances of the same firebox and output have differing canopies or external cladding both in size and materials of construction (e.g. where the hot surface would be likely to be closer to combustible surfaces or there is a change from a lower to a higher conductivity or emissivity material) then at least one appliance shall be chosen which will be the worst scenario case and will

demonstrate the safety of the range as regards surface temperature and safety of adjacent combustible materials.

Where the manufacturer claims conformity to the standard for a family of appliances on a number of different fuel types a selection of tests shall be made which demonstrates the conformity of the family in respect of the safety (Clause 5) and performance (Clause 6) on these fuels on the appliances especially to the list of characteristics detailed in Table 1 and Table 2.

The parameters, characteristics examined and considerations taken into account in making the decisions in relation to the family or range of appliances shall be recorded and a copy included in the production documentation for each appliance of the family or range (see 4.1).

9.2.2 Further type testing

Whenever a change occurs in either the appliance design, the raw material, the supplier of the components, or the production process, which would significantly alter the performance characteristics of the appliance especially in respect of one or more of the list of characteristics detailed in Table 1 and Table 2, the type tests shall be repeated for the appropriate characteristic(s).

It shall be permissible for this further type testing to verify only selected constructional and/or performance characteristics to ensure their compliance with the requirements of this European Standard and/or with the fully type tested appliances of the family or range.

For a family or range of appliance it shall be permissible to test only selected appliances across the family or range and to verify only selected constructional and performance characteristics on the others, subject to a clear decision being made that the appliances are part of a family or range of appliances.

In deciding the constructional and/or performance characteristics to be verified or the appliances to be tested (in the case of a family or range of appliances) due account shall be taken of the performance characteristics detailed in Table 2 together with the list of characteristics detailed in Table 1. The list of characteristics in Table 1 and Table 2 is not definitive and other aspects may need to be considered in making this judgement.

Where tests have been previously performed in accordance with the provisions of this European Standard then these test results shall also be taken into account in making the decision.

The parameters and characteristics considered in making either the decisions in relation to the constructional and/or performance characteristics to be verified or the appliances to be tested (in the case of a family or range of appliances) shall be recorded and a copy included in the production documentation for each appliance (see 4.1).

Table 1 — Characteristics to take account of in deciding family of appliances

<p>A Design, materials etc.</p> <ul style="list-style-type: none"> <input type="checkbox"/> Exterior design, dimensions, weight etc. <input type="checkbox"/> System for air convection/radiation <input type="checkbox"/> Ashpan <input type="checkbox"/> Materials <input type="checkbox"/> Assembling methods, welding etc. <input type="checkbox"/> Other issues _____ <input type="checkbox"/> Sketches/Drawings 	<p>D Combustion air</p> <ul style="list-style-type: none"> <input type="checkbox"/> Cross sections of air ducts (primary/secondary) <input type="checkbox"/> Length of air ducts (primary/secondary) <input type="checkbox"/> Number of bendings (primary/secondary) <input type="checkbox"/> Air inlets in combustion chamber (primary/secondary) <input type="checkbox"/> Pre-heating of air <input type="checkbox"/> Air control system <input type="checkbox"/> Other issues _____
<p>B Combustion chamber</p> <ul style="list-style-type: none"> <input type="checkbox"/> Dimensions of combustion chamber <input type="checkbox"/> Flue baffle plate(s) arrangement <input type="checkbox"/> Refractory material/insulation <input type="checkbox"/> Front firebars/deepening plate <input type="checkbox"/> Temperature conditions <input type="checkbox"/> Firedoor arrangement, glass component/area <input type="checkbox"/> Bottom grate, de-ashing system <input type="checkbox"/> Other issues _____ 	<p>E Integral fuel storage container</p> <ul style="list-style-type: none"> <input type="checkbox"/> Size <input type="checkbox"/> Protection against transfer of heat <input type="checkbox"/> Insulation <input type="checkbox"/> Other issues _____
<p>C Flue ways</p> <ul style="list-style-type: none"> <input type="checkbox"/> Cross sectional area <input type="checkbox"/> Length of flue gas passages <input type="checkbox"/> Flue spigot <input type="checkbox"/> Pressure loss <input type="checkbox"/> Transfer of heat <input type="checkbox"/> Insulation <input type="checkbox"/> Other issues _____ 	

Table 2 — Performance characteristics to take account of in deciding family of appliances

Performance characteristic	Requirement clauses in this EN
Fire safety	4.2.1, 4.2.2, 4.2.3, 4.2.4, 4.2.5, 4.2.6., 4.2.8, 4.2.9, 4.2.11, 5.1, 5.2, 5.3
Emission of combustion products	4.2.1, 4.2.3, 4.2.7, 4.2.8, 4.2.10, 4.2.11, 5.1, 6.1, 6.2, 6.4
Surface temperature	4.2.1, 5.1, 5.2, 5.3
Electrical safety	5.4
Cleanability	4.2.2, 4.2.4, 4.2.5, 4.2.6
Flue gas temperature	6.1
Mechanical resistance (to carry a chimney/flue)	4.2.1, 4.2.3
Thermal output/energy efficiency	6.3, 6.4 to 6.6
Thermal storage capacity	6.6

9.3 Factory production control (FPC)

9.3.1 General

The manufacturer shall establish, document and maintain a permanent FPC system and identify areas of responsibility to ensure that the products placed on the market conform to the stated performance characteristics. The FPC system shall consist of procedures, regular inspections and tests and/or assessments and the use of the results to control raw and other incoming materials or components, equipment, the production process and the product and shall comply with the requirements specified in 9.3.2 to 9.3.8.

NOTE A permanent FPC system conforming to the requirements of either EN ISO 9001 or an otherwise equivalent system and made specific to the requirements of this European Standard is considered to satisfy the above requirements.

The manufacturer shall carry out FPC tests to monitor the conformity of the product. Sampling, testing or assessment shall be undertaken in accordance with ISO 2859. The results of inspections, tests or assessments requiring action shall be recorded, as shall any action taken. The action to be taken when control values or criteria are not met shall be recorded.

9.3.2 Raw materials and components

The specifications of all incoming raw materials and components shall be appropriate for the intended use and shall be documented, as shall the inspection and testing scheme for ensuring the conformity of these materials and components.

9.3.3 Control of inspection, measuring and test equipment

All weighing, measuring and testing equipment used to demonstrate conformance of the product shall be calibrated and regularly inspected according to documented procedures, frequencies and criteria.

9.3.4 Process control

The manufacturer shall identify and plan the production processes, which directly affects the product characteristics and shall ensure that these processes are carried out under controlled conditions. Where the required product characteristics cannot be fully verified by subsequent inspection and testing of the product, then the production processes shall be carried out by operators specifically trained to undertake this work.

9.3.5 Product inspection, testing and evaluation

9.3.5.1 General

The manufacturer shall establish and maintain documented procedures for in-process and final inspection and testing, as appropriate to the product type, to ensure that the stated values of all of the product characteristics are maintained.

At least the following product characteristics, their criteria and means of control shall be included in the factory production control scheme.

9.3.5.2 Materials of construction

- a) Type – composition/specifications.
- b) Thickness.
- c) Dimensions.
- d) Finish.

A supplier's declaration for material type and properties is accepted, provided that the supplier has an appropriate factory production control system to ensure the adequacy, consistency and accuracy of the material type and properties.

9.3.5.3 Insulation material

- a) Specification of insulation material.
- b) Density value - thermal conductivity.

A supplier's declaration for material type and properties is accepted, provided that the supplier has an appropriate factory production control system to ensure the adequacy, consistency and accuracy of the material type and properties.

9.3.5.4 Seals and sealant materials

- a) Type - Including identification or composition, when a conformity certificate is not available.
- b) Dimensions.

A supplier's declaration for material type and properties is accepted, provided that the supplier has an appropriate factory production control system to ensure the adequacy, consistency and accuracy of the material type and properties.

9.3.5.5 Manufacturing checks

9.3.5.5.1 Construction and dimensions

Construction and dimensions of critical parts shall be confirmed during the manufacturing and/or on completion as follows:

- a) flue spigot;
- b) flueways;
- c) ashpan;
- d) bottomgrate;

- e) air supply – thermostat, manual control, inlet size etc.;
- f) control of flue gas (damper);
- g) firedoors/charging doors;
- h) flue by pass;
- j) front firbars;
- k) firebox/combustion chamber construction;
- l) convection system.

9.3.5.5.2 Other checks

At least the following check shall be carried out during the manufacturing process:

- fitment of moving/interconnecting parts.

9.3.6 Non conforming products

The manufacturer shall establish and maintain documented procedures to ensure that where the product does not conform to the specified requirements then it is clearly identified and its placing on the market prevented. These procedures shall provide for documentation and segregation of the product and for notification to the various functions concerned. Any repaired and/or reworked products shall be re-inspected in accordance with the inspection, testing and evaluation plan.

9.3.7 Corrective and preventive action

The manufacturer shall establish and maintain documented procedures for implementing corrective and preventive action. The manufacturer shall implement and record any changes to the documented procedures resulting from corrective and preventive action.

9.3.8 Handling, storage, packaging, preservation and delivery

To the extent necessary to ensure conformity of the product to the specified requirements the manufacturer shall establish and maintain documented procedures for handling, storage, packaging, preservation and delivery of the finished product following final inspection and test.

Annex A **(normative)**

Test methods

A.1 Test environment

A.1.1 Ambient room temperature

The ambient room temperature of the test laboratory shall be measured at a point lying on a circumference of a circle with a radius of $(1,2 \pm 0,1)$ m traced from the side of the appliance, at a height of $(0,50 \pm 0,01)$ m above the bottom of the appliance and away from any direct radiation.

For measurement of the ambient room temperature, a thermocouple or other temperature measuring device shall be placed, protected from radiation by an open ended cylindrical metal screen, with open ends and made of polished aluminium or material of equivalent reflectivity, nominal 40 mm in diameter and 150 mm long. The thermocouple or other temperature measuring device shall meet the uncertainty of measurement requirements specified in A.3.

A.1.2 Cross-draught

Cross-draught in the vicinity of the test appliance and its surroundings shall not be greater than 0,5 m/s measured at the location in accordance with A.1.1.

A.1.3 External sources

The test assembly shall be protected from direct influence of other heat sources, e.g. adjacent test assemblies and sunlight.

A.2 Test assembly

A.2.1 General

The test assembly shall consist of the test appliance installed in accordance with the appliance manufacturer's installation instructions into a trihedron as specified in A.2.2.

Slow heat release appliances generally have a large mass and therefore these appliances together with the test assembly shall not be mounted on a platform scale. The mass of the fuel load, in accordance with the manufacturer's instructions, shall be weighed separately on a platform scale prior to being added into the appliance such that the accuracy requirements specified in A.3 are met.

The appliance shall be positioned so that the sides facing the trihedron walls are at the manufacturer's minimum declared distance from combustible material.

A measurement section constructed in accordance with A.2.3 shall be provided with means for determining the flue gas temperature in accordance with A.2.3.2, the flue gas composition in accordance with A.2.3.3 and the applied flue draught in accordance with A.2.3.4.

The appliance shall be connected to the measurement section using the method of connection detailed in the appliance installation instructions.

The flue gases shall be extracted from the top of the measurement section and a means of adjustment shall be provided to enable a constant flue draught pressure as specified in the relevant test procedures to be maintained in the measurement section (e.g. by an extraction fan).

NOTE Examples of typical installations are given in Figures A.1 and A.2.

A.2.2 Trihedron

The trihedron shall consist of a hearth, a side wall and a rear wall each at right angles one to the other. For those appliances where it is necessary to measure the temperature of the ceiling then a ceiling shall also be fitted in accordance with the manufacturer's installation instructions.

NOTE 1 Examples of the general arrangement and construction of the trihedron are given in Figures A.3 and A.4.

The trihedron hearth and walls shall be constructed as illustrated in Figure A.5 or have a construction of equivalent thermal performance. The trihedron shall extend laterally beyond the appliance's external dimensions by at least 150 mm, and vertically by at least 300 mm above the top most surface of the appliance.

For appliances with a horizontal outlet the rear wall shall have an opening through which the flue gas connector can pass, with a clearance of (150 ± 5) mm around the connector

The maximum surface temperatures of the trihedron test hearth and walls and/or ceiling shall be determined. These temperatures shall be measured using calibrated equipment meeting the accuracy requirements specified in A.3. The position of the measurement points shall be as illustrated in Figure A.6. However only sufficient number of those measurement points in and around the hottest zone need be fitted with calibrated thermocouples and used for measurement purposes provided it is ensured that the maximum surface temperature achieved shall be recorded. Each thermocouple shall be secured so that its junction is level with the trihedron surface as illustrated in Figure A.7.

NOTE 2 Other measurement equipment similar to thermocouples may be used provided it is ensured that the actual maximum surface temperatures of the trihedron test hearth and walls are measured and recorded and that the equipment used is calibrated such that it meets the accuracy requirements specified in A.3.

If the highest temperature is measured at the periphery of the trihedron and/or ceiling then the trihedron floor or walls and/or ceiling shall be extended by at least 150 mm beyond the point of highest temperature.

A.2.3 Measurement section

A.2.3.1 General arrangement

The constructional details and general arrangement of the measurement section shall be as illustrated in Figure A.8.

The measurement section shall be provided with means of measuring the temperature and composition of the flue gas and also with means to measure the static pressure as detailed in A.2.3.2 to A.2.3.4.

The measurement section shall be fully lagged with 40 mm thick mineral fibre or similar material in order to provide a thermal conductivity of 0,04 W/m. K at an average temperature of 20 °C. The dimensions of the measurement section shall be as detailed in Figures A.9 and A.10 and be sized in accordance with the diameter of the flue spigot/socket of the appliance.

A.2.3.2 Flue gas temperature measurement

The flue gas temperature shall be measured by a sensing element e.g. a thermocouple located inside a suction pyrometer as shown in Figure A.8, with the sealed end touching the opposite wall of the measurement section and with the open outlet end connected to a suction pump. The thermocouple shall be protected by a sheath. A suitable fitting shall be provided to give a gas-tight seal between the suction pyrometer and the wall of the measurement section and between the sensing element and the outlet of the pyrometer.

The suction pyrometer probe shall have 3 sampling holes each within $(2,5 \pm 0,5)$ mm in diameter, one positioned at the centre of the measurement section and the other two positioned either side at one quarter of the flue diameter distance from the side walls of the measurement section. The extremity of the temperature-sensing element shall be placed at the position shown in Figure A.8.

The inside diameter of the suction pyrometer shall be (5 ± 1) mm and the flow rate shall be adjusted in order to obtain a flow velocity within the range of 20 m/s to 25 m/s.

NOTE The high flow rate necessary to achieve the specified range of flow velocity may be limited through the flue gas analysers by use of a bypass arrangement.

A.2.3.3 Flue gas sampling

The suction pyrometer probe shall be used for flue gas sampling. The outlet of the suction pyrometer probe shall be connected to a flue gas analysis system meeting the uncertainty of measurement specified in A.3. Means of cooling, cleaning and drying the flue gas sample shall be incorporated in the sampling line.

The materials used for the gas sampling line and probe connections shall be resistant to the expected temperature and shall not react with or allow diffusion of flue gases. There shall be no leaks in either the sampling probe connections or the gas sampling line.

A.2.3.4 Static pressure measurement

A tube with a nominal internal diameter of 6 mm shall be located into the measurement section as shown in Figure A.8. The end of the tube shall be sealed flush with the inner wall of the measurement section.

A.2.4 Connection of appliance to measurement section

The appliance flue spigot/socket shall be connected to the measurement section specified in A.2.3 by an un-insulated flue gas connector and an insulated flue gas adaptor. The flue gas connector shall be made of unpainted mild steel with a thickness of $(1,5 \pm 0,5)$ mm. Its length shall be (330 ± 10) mm and correspond to the diameter of the flue spigot/socket of the appliance. Where a flue gas connector longer than (330 ± 10) mm is required for connecting the appliance to the measurement section in accordance with the manufacturer's instructions then only 330 mm of its length shall be left uninsulated and any length greater than this shall be insulated to the same level as detailed in A.2.3.1.

The flue gas adaptor shall be connected between the measurement section and the flue gas connector. The flue gas adaptor shall have the same diameter as the measurement section and shall be insulated to the same level as detailed in A.2.3.1.

For appliances with a non-circular outlet or with a diameter different from that of the measurement section, the flue gas connector shall be an adaptor, which accommodates the necessary changes in the shape and/or dimensions to match the measurement section diameter.

For appliances with horizontal outlet, the flue gas adaptor shall have a radius of (225 ± 5) mm at its centre. For appliances with vertical outlet the flue gas adaptor shall be straight and of length (350 ± 10) mm.

NOTE Some general arrangements are shown in Figures A.1, A.2, A.9 and A.10.

A.2.5 Measurement of appliance surface temperature for slow heat release appliances

A.2.5.1 General

The surface temperature of each of the appliances' exterior surfaces shall be measured against ambient temperature. In order to accurately measure the mean surface temperature it is essential a sufficient number of temperature measurement points be chosen on each surface so that the measurement points give a reasonably good estimate of the mean temperature of that surface.

If the appliance construction is symmetrical in relation to flueways and other construction and also in respect of front, back and side walls then it is permissible to only measure the temperature of only one side wall and one half of the other surfaces. Detailed requirements on choosing the specific measurement points are given in A.2.5.2

If the construction is not symmetrical or has significant differences then all independent surfaces must be measured separately and more measurement points will be needed as detailed in A.2.5.2.

The mean surface temperature should be given as weighted mean surface temperature. Calculation is based on values of separate measurement points and their representing surface area as detailed in A.6.2.7.

Mean differential surface temperature against ambient room temperature gives an estimate about the heat release rate of the appliance versus time. In this European Standard only the mean differential surface temperature curve is measured, and the times when it is at the maximum, 50 % of the maximum and finally 25% of the maximum are reported.

NOTE Informative Annex C details a calculation method for performing this conversion.

A.2.5.2 Selection of measurement points

If the appliance is symmetrical then the appliance's back, front, top and side external surfaces shall be divided into two identical surface areas by a vertical line. The mean differential surface temperature of only one half of the back, front and top surfaces and only one of the side walls surfaces shall be measured. Each surface area to be measured shall then be further sub-divided into smaller areas not exceeding 0,3 m × 0,3 m and at least one measurement point is needed for each of these smaller areas. The temperature measurement shall be made at the symmetrical centre point of the surface areas that it is representing.

NOTE It may be necessary to undertake a preliminary temperature survey to check that the temperature profiles of the surfaces are symmetrical.

The differential surface temperature of the door shall be measured from at least two points. The surface area of the door shall be divided by vertical and horizontal lines into four identical areas. One measurement point shall be placed on the centre point of the bottom left hand area and the other measurement point on the centre point of the top right hand area.

If the appliance is not symmetrical in respect of the geometry of its flue ways or surfaces then each of the appliance's surfaces shall be sub-divided into small areas not exceeding 0,3 m × 0,3 m and at least one measurement point shall be required for each 0,3 m × 0,3 m area. The temperature measurement shall be made at the symmetrical centre point of the surface area that it is representing.

The mean differential surface temperature of the appliance shall be calculated based on area-weighted differential temperature measurement points as detailed in A.6.2.7. A typical example of the positioning of the measurement points is given in Figure A.11.

A.2.5.3 Installing thermocouples to the appliance surface

If thermocouples are used then they shall be installed such that the actual surface temperature measurements meet the uncertainty requirements of Table A.1. Either commercially available adhesive patch thermocouples shall be used or alternatively either special glue or nail polish shall be used to ensure a good contact is made between the thermocouple and the appliance surface.

NOTE Some examples of other suitable temperature measuring devices can be given in an appendix but it is the responsibility of the test laboratory to ensure that measurements are undertaken to the required uncertainty.

A.3 Measurement equipment

The measurement equipment used shall be selected to ensure that for each measurement parameter the uncertainty requirements specified in Table A.1 are met. The peak value of the parameter to be measured shall be in the range of the measurement equipment used.

Table A.1 — Uncertainty of measurement

Parameter measured	Uncertainty of measurement
Gas analysis	
CO	≤ 6 % of the measurement range
CO ₂	≤ 2 % of the measurement range
O ₂	≤ 2 % of the measurement range
Temperature	
Flue gas	≤ 5 K
Ambient room	≤ 1,5 K
Surface	≤ 2 K
Touchable Area	≤ 2 K
Cross-draught	≤ 0,1 m/s
Static pressure	≤ 2 Pa
Mass	
Fuel consumption	± 20 g
Residue	± 5 g
Fuel load ≤ 7,5 kg	± 5 g
> 7,5 kg	± 10 g

A.4 Test procedures

A.4.1 Appliance installation

The appliance shall be installed into the test assembly as specified in A.2, in accordance with the appliance manufacturer's installation instructions. The appliance shall be connected to the measurement section following the method of connection detailed in the appliance manufacturer's installation instructions

If the appliance is supplied in individual part, the manufacture's specifications as given in the installation instructions shall be followed during assembly.

For appliances with a rear flue outlet, the flue gas connector shall pass through the trihedron wall. The hole around the flue gas connector shall be filled with insulating material (see Figure A.4).

Where a draught regulator is fitted between the firebed and the flue spigot/socket then, for the burning rate performance test, either the regulator is removed and the opening sealed with a suitably sized solid plate or the regulator itself is sealed e.g. with heat resistant tape so as to avoid the ingress of air through the stabiliser opening.

The differential surface temperature thermocouples shall be installed onto the exterior surfaces of the appliance as specified in A.2.5.

A.4.2 Fuel load

For the burning rate performance test the fuel load for each firing regime shall be declared by the manufacture in the appliance operating instructions. The test shall be carried out with the fuel loading mass declared by the manufacturer and can be added as batch charges if the manufacturer indicates in the appliance operating instructions that this is allowed. As specified in 6.5 any batch charge shall be not less than 20 % of the total fuel loading.

A.4.3 Fuelling and de-ashing the fire

Select and prepare the test fuel in accordance with Annex B.

Where the test fuels are fuels other than wood logs or peat briquettes load them onto the firebed so as not to pack them artificially.

For wood logs or peat briquettes refuel in accordance with the appliance manufacturer's refuelling instructions and take account of any recommendations regarding general orientation as well as log size in the case of wood logs.

For test fuels other than wood logs where de-ashing may not be necessary or peat briquettes, the de-ashing procedure shall be thorough and shall be carried out in accordance with the manufacturer's operating instructions. For appliances with under grate ash removal observe the residue material falling through the grate bars by opening or removing the ashpit door/cover and continue de-ashing until burning fuel begins to be discharged.

A.4.4 Flue gas losses

A.4.4.1 General

Calculate the flue gas losses from the composition and temperature of the flue gases in accordance with A.6. The composition and temperature of the flue gases and the ambient room temperature shall be measured as specified in A.4.4.2 and A.4.4.3.

A.4.4.2 Composition of the flue gas

Measure the concentration of the products of combustion (CO_2 or O_2 , and CO) either continuously or at intervals not exceeding 1 min using calibrated instruments meeting the uncertainty of measurement requirements specified in A.3. Determine the mean values of concentration of the products in the dry flue gas as specified in A.6.

A.4.4.3 Ambient room and flue gas temperatures

Measure both the flue gas temperature and ambient room temperature using calibrated instruments that meet the uncertainty of measurement requirements specified in A.3.

Measure and record both the flue gas temperature and the ambient room temperature either continuously or at intervals not exceeding 1 min.

At the end of the test period, calculate and record the mean ambient room temperature and the mean flue gas temperature as specified in A.6.

A.4.5 Combustible heat losses in the residue

For appliances with a bottom grate and where the test fuel is any solid fuel except wood logs, set aside the residue and allow it to cool. Determine and record the mass of the residue, in kilograms, to the nearest 2 g. Analyse the residue and record its combustible constituents as a percentage of the residue. Calculate the % heat loss in the residue according to the equation given in A.6.2.1.4.

If the test fuel is wood logs then the combustible constituents of the residue need not be measured but can be taken as 0,5 % points of efficiency.

A.4.6 Burning rate performance test

A.4.6.1 General

The test is started from cold without a pre-test period and the ignition and test period shall be conducted as detailed in A.4.6.2.

Observe the static pressure throughout the entire test and if necessary adjust the applied flue draught so that the static pressure is set to the appropriate normal flue draught value ± 2 Pa as detailed in 6.4.

A.4.6.2 Test period

The test shall be carried out with the fuel loading mass declared by the manufacturer and can be added as batch charges if the manufacturer indicates in the appliance operating instructions that this is allowed. Any batch charge shall be not less than 20 % of the total fuel loading.

The test shall be started from cold without a pre-test period. Ignition is achieved either in accordance with the manufacturer's instructions or using kindling whose mass is either 500 g or 10 % of the fuel loading declared by the manufacturer whichever is the greater. The ignition shall be carried out with any bottom air entry open.

Adjust the applied flue draught to give the appropriate static pressure in the measurement section. Measure and record from first ignition the temperature and the composition of flue gas as described in A.4.4. Measure and record from first ignition the surface temperature of each differential thermocouple on the exterior surfaces of the appliance walls either continuously or at regular intervals of not more than 1 min.

Measure and record the temperature of the trihedron test hearth and the walls either continuously or at regular intervals of not more than 1 min to ensure that the maximum temperatures achieved are recorded. Measure and record the surface temperatures of any operating knobs and intended to be operated without the use of a tool and the temperature in the fuel storage container if fitted, such that the maximum temperatures are accurately recorded.

When ignition is ensured set the combustion control devices, if necessary, to the required setting in order to achieve the required burning condition declared by the appliance manufacturer to give the claimed heat output.

Any further batch charges shall be added over the time period as defined by the manufacturer in the operating instructions but shall not exceed 3 h until the entire fuel loading mass specified by the manufacturer has been added.

The end of the burning period in respect of efficiency and emissions measurement shall be after all the fuel loading mass has been added and when either 4 % CO₂ or 25 % of the preceding CO₂ peak value is reached, whichever is the lower. Record in minutes, the duration of the burning period. Continue to measure the trihedron test hearth and wall temperatures, the surface temperatures of any operating knobs and the temperature in the fuel storage container to ensure that the maximum temperatures reached are accurately recorded. Also continue to measure the differential surface temperatures of the external surfaces of the appliance until 25 % of the mean maximum differential surface temperature is reached. When this point is reached the test period is ended. Record in minutes, the duration of the test period.

A.4.7 Temperature safety test for woodburning and multifuel appliances

A.4.7.1 General

This test shall be performed when the appliance is declared by the manufacturer to burn either wood only or both wood and solid mineral fuels.

All controls, except those used only for start-up purposes, shall be in position allowing for the highest heat output to be achieved.

The test fuel shall be test wood logs in accordance with Table B.1.

The test shall be conducted with doors closed.

A.4.7.2 Ignition and test period

The test may be started from cold or may immediately follow a previous nominal heat output test.

If starting from cold load the appliance with sufficient test fuel to ensure ignition of the fuel in accordance with the manufacturer's operating instructions. When the fuel is well alight, operate the appliance at nominal heat

output using the mass of test load as indicated by the appliance manufacturer in the operating instructions which may be added either as a single charge or as batch charges if this is declared in the operating instructions. The end of the ignition period shall be after all the fuel loading mass has been added and when either 4 % CO₂ or 25 % of the preceding CO₂ peak value is reached, whichever is the lower. The test period then begins by adding the test load as indicated by the appliance manufacturer in the operating instructions which can be added either as a single charge or as batch charges if this is declared in the operating instructions.

If started following the nominal heat output test then the safety test period begins immediately after the burning period in respect of efficiency and emissions measurement is ended when either 4 % CO₂ or 25 % of the preceding CO₂ peak value is reached, whichever is the lower. The safety test period then begins by adding the test load as indicated by the appliance manufacturer in the operating instructions which can be added either as a single charge or as batch charges if this is declared in the operating instructions.

Adjust the applied flue draught to obtain a static pressure within $^{+2}_0$ Pa of the flue draught pressure as detailed in 6.4. Set the combustion air controls at the maximum operating positions and adjust the secondary air controls to the normal setting for wood.

Observe the static pressure at approximately 15 min intervals throughout the entire test and adjust the applied flue draught, if necessary, to keep the static pressure within $^{+2}_0$ Pa of the required test value.

Measure and record the following parameters, either continuously or at regular intervals of no more than 1 min.

- the temperatures on the trihedron test hearth and walls;
- the temperature in the fuel storage container.

When the fire has gone out all inlets for combustion air shall be closed. End the test period when the maximum temperatures are achieved.

A.5 Test results

For each test fuel used, record the results of the analysis parameters specified in Annex B.

Calculate and record the mean values from at least two tests results for the burning rate performance test, in accordance with A.6, the following parameters:

- the total efficiency (%);
- the mean CO emission at 13 % O₂ (%);
- the mean flue gas temperature (°C);
- the total heat output (kJ).

Record also the test values of the individual measurements used in the calculations and the flue draught used for each test.

Record the time period from the appliance achieving the maximum mean differential surface temperature and falling to 50 % and 25% of that maximum value based upon differential surface temperatures against ambient temperatures during the performance test at burning rate performance test in accordance with A.4.6.2.

NOTE 1 Informative Annex C details a method of calculating the approximate heat release curve against time.

Record the maximum surface temperature achieved on every operating knob intended to be operated without the use of a tool during the burning rate performance test in accordance with A.4.6.2. Record the maximum temperatures of the trihedron walls and test hearth. Also record the maximum temperature achieved in any integral fuel store, if fitted.

Record whether the materials, design and constructional requirements specified in Clause 4 were met. Record whether the manufacturer's instructions for the appliance meet the requirements specified in Clause 7 and whether the marking and labelling of the appliance meet the requirements specified in Clause 8.

NOTE 2 Actual measured values of dimensions, thickness etc. together with supporting certificates and documentation should also be recorded.

A.6 Calculation methods

A.6.1 Notations and units used

The notations and units used in the calculations are given in Table A.2.

Table A.2 — Notations and units used in calculations

Notation	Definition	Unit
B	Mass of the test (as fired basis)	kg
b	Combustible constituents in residues referred to mass of residues	% of mass
C	Carbon content of test fuel (as fired basis)	% of mass
CO	Carbon monoxide content of the dry flue gases	% of volume
CO_2	Carbon dioxide content of the dry flue gases	% of volume
C_p	Specific heat of water	$\text{kJ} / \text{K} \cdot \text{m}^3$
C_r	Carbon content of the residue, referred to the quantity of test fuel fired. (Approximation : $C_r = R \times b / 100$)	% of mass
C_{pmd}	Specific heat of dry flue gases in standard conditions, depending on temperature and composition of the gases	$\text{kJ} / \text{K} \cdot \text{m}^3$
$C_{\text{pmH}_2\text{O}}$	Specific heat of water vapour in flue gases in standard conditions, depending on temperature	$\text{kJ} / \text{K} \cdot \text{m}^3$
F	Mass of test fuel burned in ten hour test period (dry, ash free basis) but without correction for combustible constituents in the residue	kg
H	Hydrogen content of the test fuel (as fired basis)	% of mass
H_u	Lower calorific value of the test fuel (as fired basis)	kJ / kg
m_f	Flue gas mass flow	g / s
η	Efficiency	%
P	Total heat output	kJ
Q_a	Thermal heat losses in the flue gases, referred to the unit of mass of the test fuel	kJ/kg
Q_b	Chemical heat losses in the flue gases, referred to the unit of mass of the test fuel	kJ/kg
Q_r	Heat losses through combustible constituents in the residue referred to the unit of mass of the test fuel (as fired basis)	kJ/kg
q_a	Proportion of losses through specific heat in the flue gases Q_a , referred to the calorific value in the test fuel (as fired basis)	%
q_b	Proportion of losses through latent heat in the flue gases Q_b , referred to the calorific value in the test fuel (as fired basis)	%

q_r	Proportion of heat losses through combustible constituents in the residues Q_r , referred to the calorific value of the test fuel	%
R	Residue passing through the grate, referred to the mass of the fired test fuel	% of mass
T_b	Minimum refuelling interval or manufacturer's declared duration	h
t_a	Flue gas temperature	°C
t_r	Room temperature	°C
V_{con}	Volume, at NTP, of carbon monoxide	dm ³
W	Water content of the test fuel (as fired basis)	% of mass
A	Stoichiometric oxygen demand for the fuel	mol O ₂ /mol fuel
c	Carbon content of the fuel (on dry ash free basis)	kg/kg
h	Hydrogen content of the fuel (on dry ash free basis)	kg/kg
m	Molar content of hydrogen	
n	Molar content of oxygen	
o	Oxygen content of the fuel (on dry ash free basis)	kg/kg
p	Molar content of sulfur	
s	Sulfur content of the fuel (on dry ash free basis)	kg/kg

A.6.2 Equations

A.6.2.1 Heat losses and efficiency

A.6.2.1.1 General

The heat losses are determined from the mean values of flue gas and room temperatures, the flue gas composition and the combustible constituents in the residue.

The efficiency is determined from these losses using the following equation:

$$\eta = 100 - (q_a + q_b + q_r) \quad (\text{A.1})$$

Where the test fuel is wood logs and where the heat loss in the residue (q_r) is taken as 0,5 % points of efficiency in accordance with A.4.5 then the value of C_r in Equations (A.3) and (A.5) below shall be calculated as follows:

$$C_r = 1,4925 \times H_u \times 10^{-5} \quad (\text{A.2})$$

A.6.2.1.2 Thermal heat losses in the flue gas

$$Q_a = (t_a - t_r) \times [[(C_{\text{pmd}} \times (C - C_r)) / (0,536 \times (CO + CO_2))] + [C_{\text{pmH}_2\text{O}} \times 1,244 \times (9H + W) / 100]] \quad (\text{A.3})$$

$$q_a = 100 \times Q_a / H_u \quad (\text{A.4})$$

A.6.2.1.3 Chemical heat losses in the flue gas

$$Q_b = 12\,644 \times CO \times (C - C_r) / [0,536 \times (CO_2 + CO) \times 100] \quad (\text{A.5})$$

$$q_b = 100 \times Q_b / H_u \quad (\text{A.6})$$

A.6.2.1.4 Heat losses due to combustible constituents in the residue

$$Q_r = 335 \times b \times R / 100 \quad (\text{A.7})$$

$$q_r = 100 \times Q_r / H_u \quad (\text{A.8})$$

A.6.2.2 Total heat output

The total heat output (in kJ) during the fuel burning period is calculated from the mass of fuel consumed, the lower calorific value of the test fuel and the efficiency determined from the heat loss measurements, using the following equation:

$$P = \eta \times B \times H_u \quad (\text{A.9})$$

A.6.2.3 Flue gas mass flow

The flue gas mass flow is determined as an approximate value from the CO₂ and CO content of the flue gases and the fuel-specific data, using the following equation:

$$m_f = [B \times (1,3) \times (C - C_r) / ((0,536) \times (CO_2 + CO)) + (9H + W) / 100] / 3,6 \quad (\text{A.10})$$

A.6.2.4 CO content

The mean values of the flue gas components such as oxygen, carbon dioxide and carbon monoxide over the test period can be calculated as an allowable approximation of the data received from the instrument readings.

With this calculation method, the mean values of the components are not weighted for possible fluctuations in mass flow over the test period, as the flue gas flow is assumed to be constant and the calculation errors are deemed to be small.

The CO content shall be calculated as follows:

- a) The mean carbon monoxide value CO_{avg} shall be calculated as the mean value of all CO data acquired from the instrument readings over the test period.
- b) The CO_{avg} value shall be converted to the CO content value based on a standard oxygen content in the flue gas according to one of the following equations:

$$CO \text{ content} = CO_{avg} \times \frac{[21 - O_{2\text{standardized}}]}{[21 - O_{2\text{avg}}]} \quad (\text{A.11})$$

$$CO \text{ content} = CO_{avg} \times \frac{CO_{2\text{max}}}{CO_{2\text{avg}}} \times \frac{[21 - O_{2\text{standardized}}]}{21} \quad (\text{A.12})$$

For this European Standard the standardized oxygen content (O_{2 standardized}) in the flue gas shall be taken as 13 %. The value of CO_{2 max} shall be calculated as detailed in A.6.2.8.

NOTE Where the CO is measured on a volume basis (vol % or parts per million) and the CO-concentration needs to be given by mass concentration (mg/m³_n) the mean value CO_{avg} should be changed using the following equations:

- a) if CO is measured as parts per million (ppm):

$$CO_{avg} \text{ (mg/m}^3\text{)}_n = CO_{avg} \text{ (ppm)} \times d_{co} \quad (\text{A.13})$$

- b) if CO is measured as percentage (vol %):

$$CO_{avg} \text{ (mg/m}^3\text{)}_n = CO_{avg} \text{ (vol \%)} \times d_{co} \times 10\,000 \quad (\text{A.14})$$

where d_{co} is the density of carbon monoxide at standard condition [$d_{co} = 1,25 \text{ kg/m}^3_n$].

A.6.2.5 Specific heat value of the combustion products

A.6.2.5.1 Specific heat of dry flue gases in standard conditions (C_{pmd})

The specific heat of the dry flue gases in standard conditions (C_{pmd}) is calculated using the following equation:

$$\begin{aligned}
 C_{pmd} = & 3,6 \times \left(0,361 + 0,008 \times \left(\frac{t_a}{1000} \right) + 0,034 \times \left(\frac{t_a}{1000} \right)^2 \right) \\
 & + \left(0,085 + 0,19 \times \left(\frac{t_a}{1000} \right) - 0,14 \times \left(\frac{t_a}{1000} \right)^2 \right) \times \left(\frac{CO_2}{100} \right) \\
 & + \left(0,3 \times \left(\frac{t_a}{1000} \right) - 0,2 \times \left(\frac{t_a}{1000} \right)^2 \right) \times \left(\frac{CO_2}{100} \right)^2
 \end{aligned} \tag{A.15}$$

A.6.2.5.2 Specific heat of water vapour (C_{pmH2O})

The specific heat of the water vapour (C_{pmH2O}) in the combustion products is calculated using the following equation:

$$C_{pmH2O} = 3,6 \times \left(0,414 + 0,038 \times \left(\frac{t_a}{1000} \right) + 0,034 \times \left(\frac{t_a}{1000} \right)^2 \right) \tag{A.16}$$

A.6.2.6 Volume, at NTP, of carbon monoxide (V_{CO_n})

The volume, at NTP, of the carbon monoxide (V_{CO_n}) during the 10 hour period of the natural draught safety test is calculated in dm^3 according to the following equation:

$$V_{CO_n} = \frac{C \times F}{0,536 \times (CO_2 + CO)} \times CO \times 10 \tag{17}$$

A.6.2.7 Calculation of mean differential surface temperatures of slow heat release appliances

Firstly calculate the mean differential surface temperature of each individual external surface of the appliance (e.g. top, front). For each of these external surfaces calculate from the mean value of the readings over the test period of each differential thermocouple measurement point and weight by the actual surface area that the measurement point represents. A typical calculation is detailed in example 1 below.

EXAMPLE 1

Top surface having four measurement points. Two measurement points have an area of 0,3 m by 0,3 m i.e. 0,09 m^2 and mean differential temperature values of 60 K and 55 K respectively over the test period. The other two measurement points have an area of 0,25 m by 0,25 m i.e. 0,0625 m^2 and mean differential temperature values of 50 K and 55 K respectively over the test period. The mean value of the differential temperature of the surface would be calculated as follows:

$$\text{Mean value} = \frac{(60 \times 0,09) + (55 \times 0,09) + (50 \times 0,0625) + (55 \times 0,0625)}{(0,09 \times 2) + (0,0625 \times 2)} = 55,45 \text{ K}$$

NOTE If the actual surface areas of the measurement points are all of the same area then the mean differential temperature of the surface can be calculated as the arithmetic mean of the individual differential readings of each measurement point.

Secondly calculate the mean differential temperature of the appliance from the calculated mean of each of the individual external surfaces from step 1 and weight by the actual surface area of the individual surface of the appliance that it represents e.g. front, top. A typical calculation is detailed in example 2 below.

EXAMPLE 2

The individual mean calculated differential surface temperatures from step 1 are given in column 2 and the corresponding surface areas of each of the appliance sides are given in column 3 of the Table A.3 below. Column 4 is the weighted value and is calculated by multiplying the value in column 2 by the value in column 3 for each of the appliance surfaces. The mean value for the differential surface temperature of the appliance is calculated by dividing the total weighted value by the total surface area.

Tabelle A.3 — Example of calculation of mean differential surface temperature

	Mean calculated value of differential surface temperature K	Surface area m ²	Weighted Value
Top	65	0,75	48,75
Front	70	1,50	105,00
Back	60	1,50	90,00
Sides	55	2,00	110,00
Totals		5,75	353,75
Mean value for appliance	61,5	Mean value = $\frac{\text{Total weighted value}}{\text{Total surface area}}$	

A.6.2.8 Calculation of $CO_{2\max}$

The value of $CO_{2\max}$ used in Equation (A.12) is calculated as follows:

$$CO_{2\max} = \frac{1}{[1 + p + A \times (79/21)]} \quad (\text{A.18})$$

The values of A and p used in Equation (A.18) are calculated as follows:

$$A = 1 + (m/4) - (n/2) + p \quad (\text{A.19})$$

$$p = (12/32) \times (s/c) \quad (\text{A.20})$$

where

$$m = 12 \times (h/c) \quad (\text{A.21})$$

$$n = (12/16) \times (o/c) \quad (\text{A.21})$$

NOTE Ultimate analysis of the fuel is necessary for these calculations so that the content of carbon, hydrogen, sulfur and oxygen on a dry, ash free basis are known.

A.7 Test report

Each page of the test report shall be numbered consecutively and shall specify the results of the testwork and any other additional information and shall contain at least the following details concerning the testwork undertaken on the appliance:

- a) name and address of the appliance manufacturer;
- b) name, serial number and description of the appliance;
- c) statement describing whether the materials, design and construction requirements specified in Clause 4 are met or failed, supported by actual measured values of dimensions, thicknesses etc. together with certificates as appropriate;
- d) statement describing whether the safety requirements specified in Clause 5 and the performance requirements specified in Clause 6 are met or failed, supported by detailed test results as specified in A.5;
- e) statement describing whether the installation and operating instructions comply with the requirements specified in Clause 7;
- f) copy of the marking information given on the appliance, and a statement whether the marking information complies with the requirements specified in Clause 8;
- g) name and address of the test laboratory;
- h) unique serial number for the report;
- j) date of issue of the report;
- k) signature and legible name of the person taking responsibility for the content of the report;
- l) analysis and specifications of the test fuels used during the testwork.

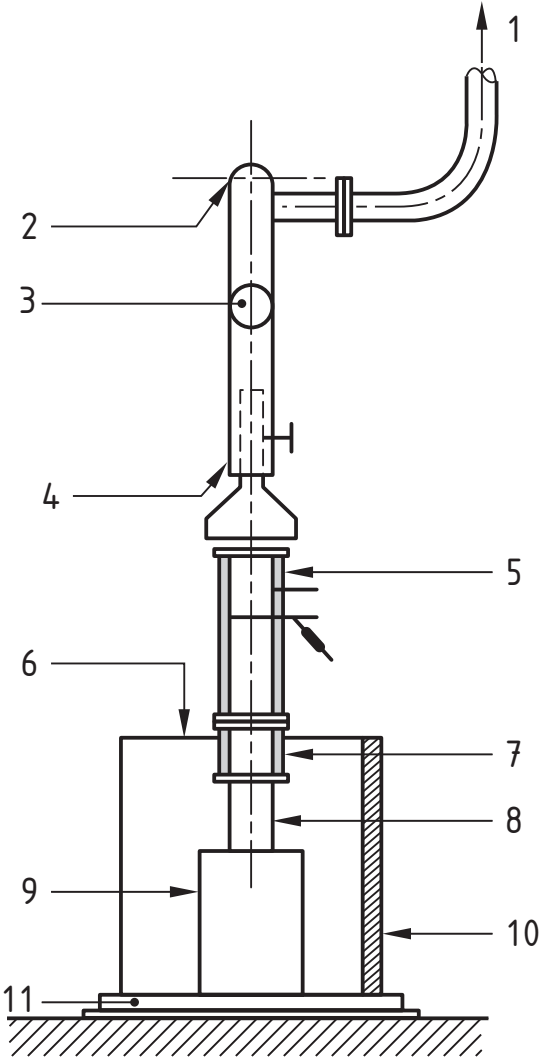

Key

- | | | | |
|---|------------------------|----|-----------------------------|
| 1 | exhaust to atmosphere | 7 | flue gas adaptor - straight |
| 2 | fan | 8 | flue gas connector |
| 3 | adjustable damper | 9 | appliance |
| 4 | adjustable gather | 10 | trihedron side wall(s) |
| 5 | measurement section | 11 | trihedron test hearth |
| 6 | trihedron side wall(s) | | |

Figure A.1 — Example of installation of an appliance with vertical flue outlet in the test assembly

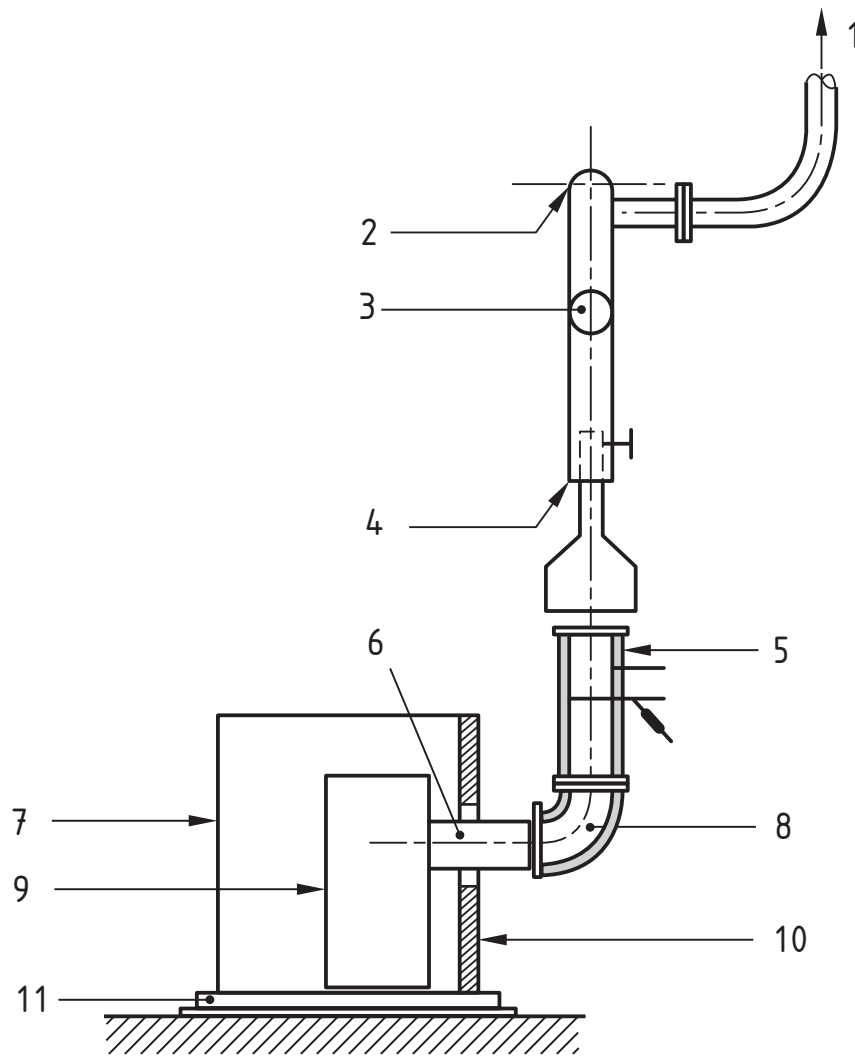

Key

1	exhaust to atmosphere	7	trihedron side wall(s)
2	fan	8	flue gas adaptor - bend
3	adjustable damper	9	appliance
4	adjustable gather	10	trihedron side wall(s)
5	measurement section	11	trihedron test hearth
6	flue gas connector		

Figure A.2 — Example of installation of an appliance with horizontal flue outlet in the test assembly

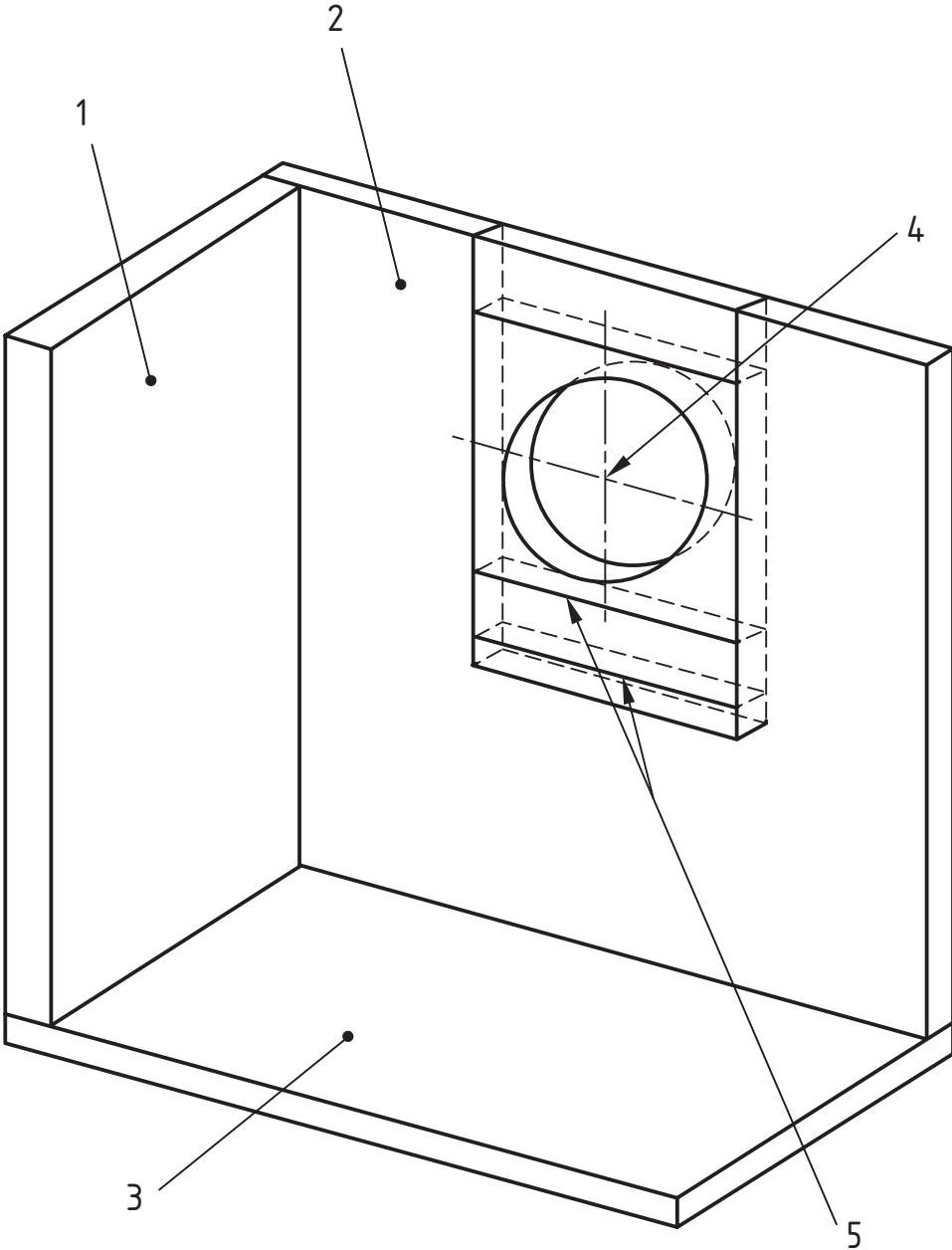

Key

- 1 side
- 2 rear wall
- 3 test hearth
- 4 centre line of flue gas connector
- 5 filler pieces

Figure A.3 — View of trihedron showing general arrangement of walls and test hearth

Licensed copy: Lee Shau Kee Library, HKUST, Version correct as of 03/01/2015, (c) The British Standards Institution 2013

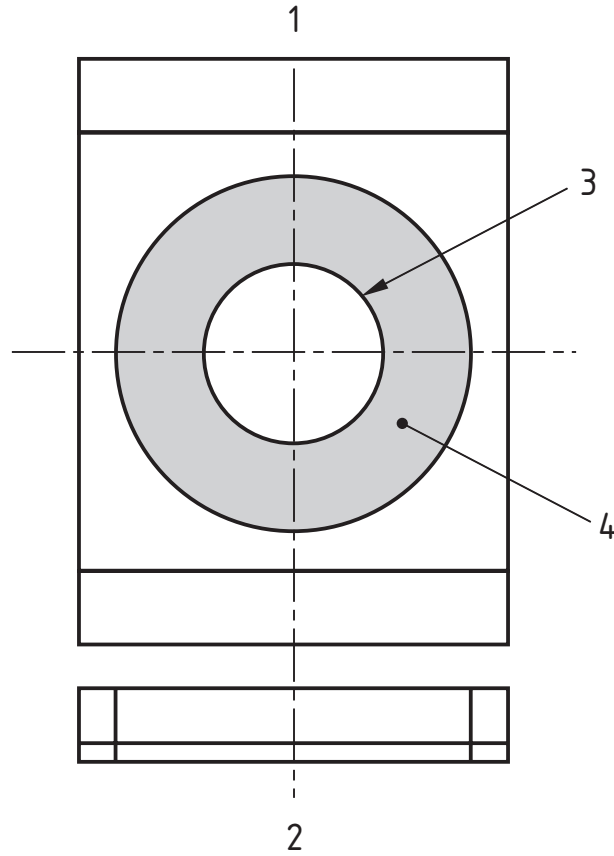

Key

- 1 elevation
- 2 plan view
- 3 flue gas connector
- 4 clearance of (150 ± 5) mm around the flue gas connector filled with insulation

Figure A.4 — Detail of filler pieces for trihedron rear wall

Dimensions in millimetres
Tolerance on dimensions ± 1 mm

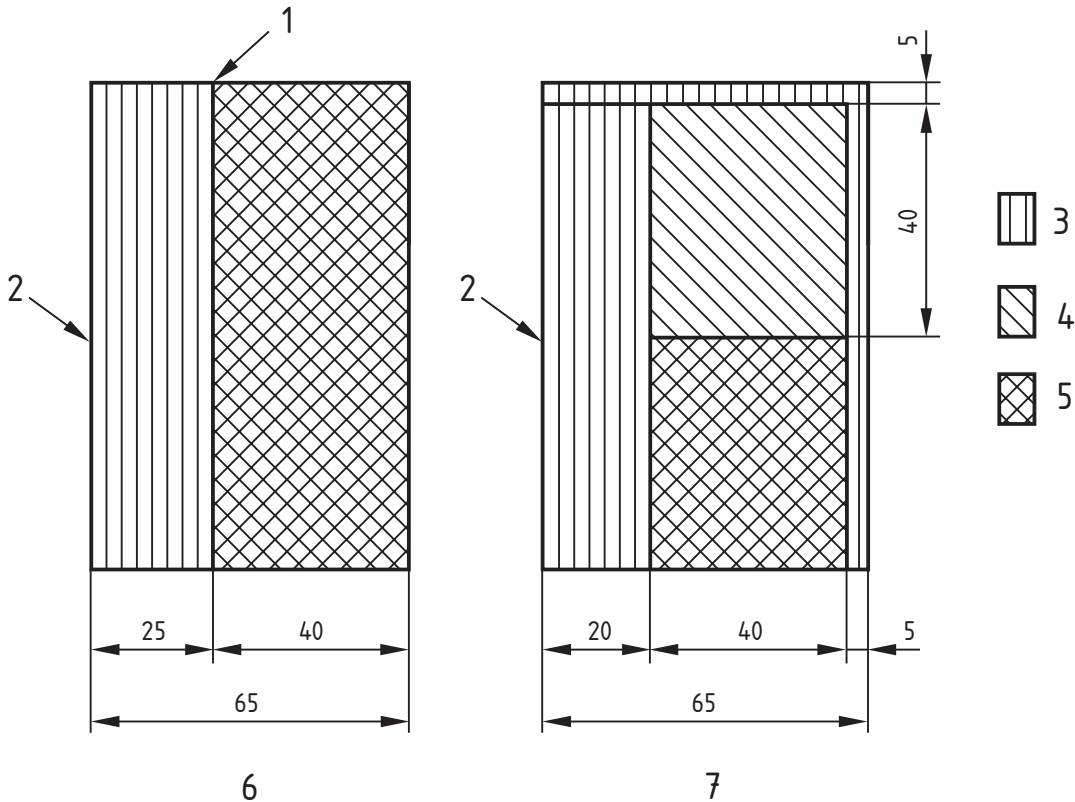

Key

- 1 adhesive
- 2 black cover
- 3 plywood board
- 4 squared timber
- 5 insulation (fibre or plates) thermal conductivity 0,04 W/mK
- 6 example 1
- 7 example 2

Figure A.5 — Cross section showing trihedron construction

Licensed copy: Lee Shau Kee Library, HKUST, Version correct as of 03/01/2015, (c) The British Standards Institution 2013

Dimensions in millimetres
Tolerance on dimensions ± 1 mm

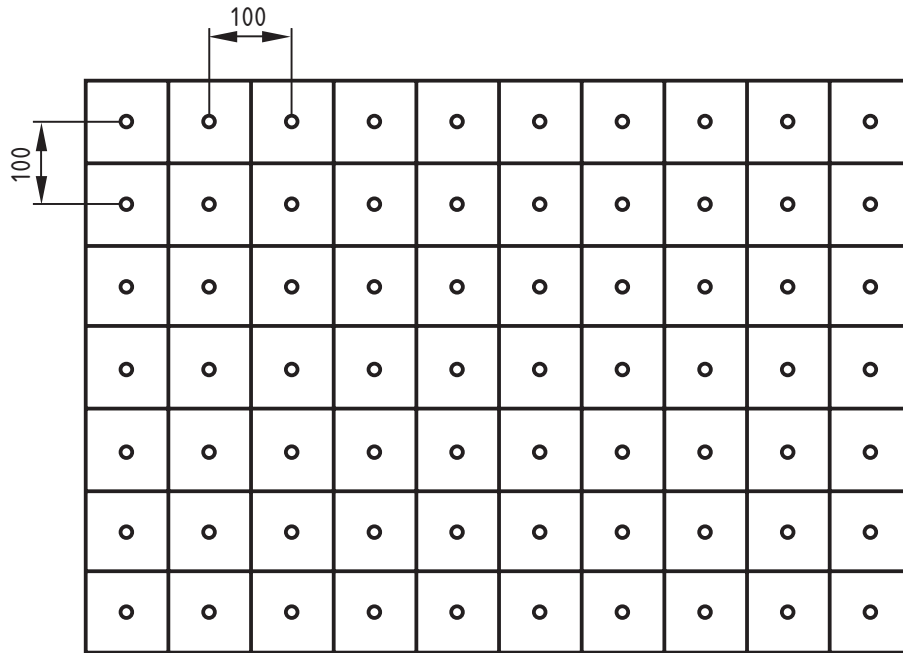
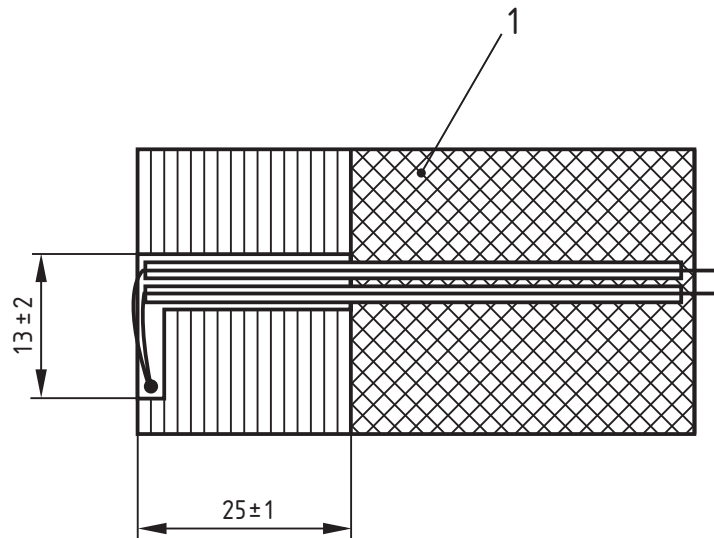

Figure A.6 — Plan view of trihedron hearth and walls showing position of possible measurement points

Dimensions in millimetres



Key

- 1 trihedron wall

Figure A.7 — Detail of thermocouples in trihedron wall

Dimensions in millimetres

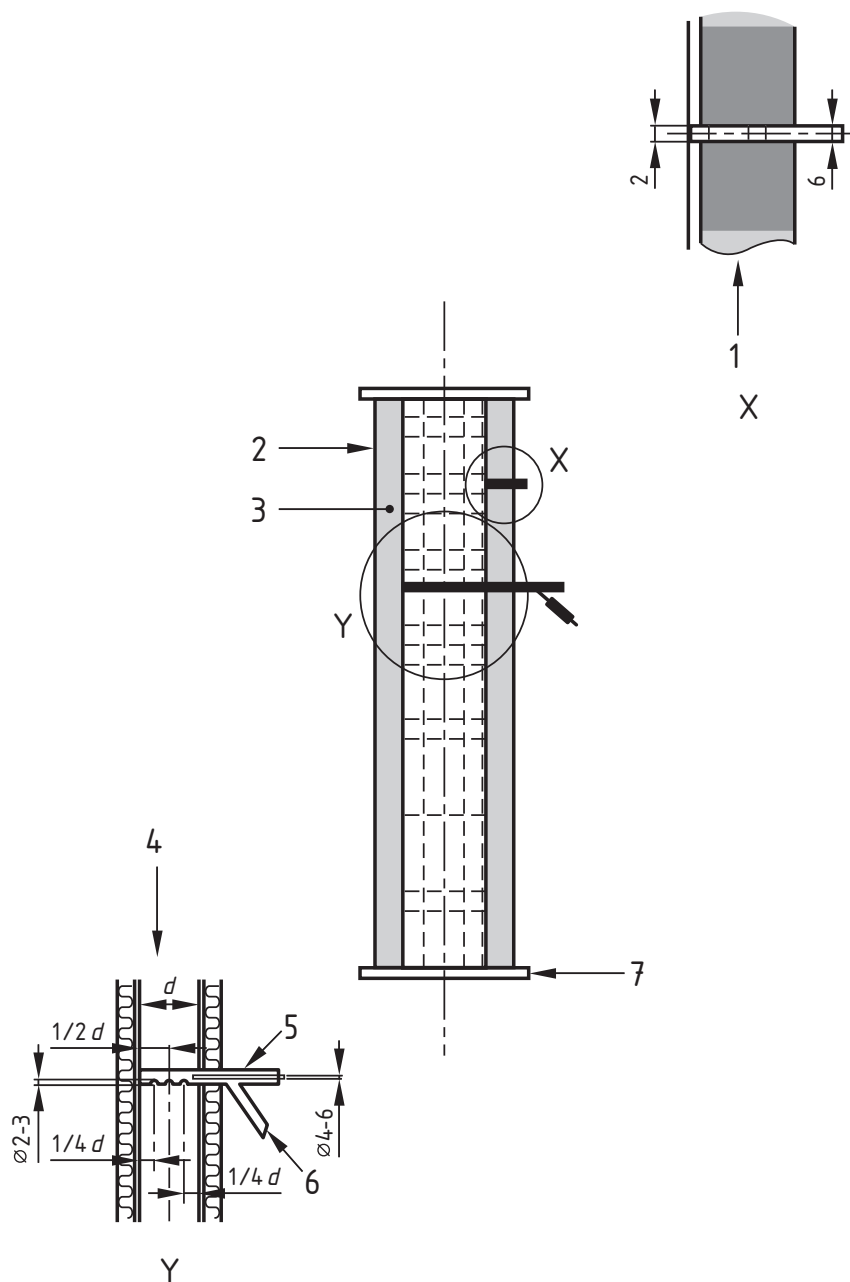
**Key**

- 1 static pressure measurement
- 2 measurement section
- 3 insulation
- 4 measurement of flue gas temperature and constituents
- 5 outlet for sensing element
- 6 outlet for flue gas sampling
- 7 flange

Figure A.8 — Construction and general arrangement of measurement section

Dimensions in millimetres
Tolerance on dimensions ± 1 mm
except where shown otherwise

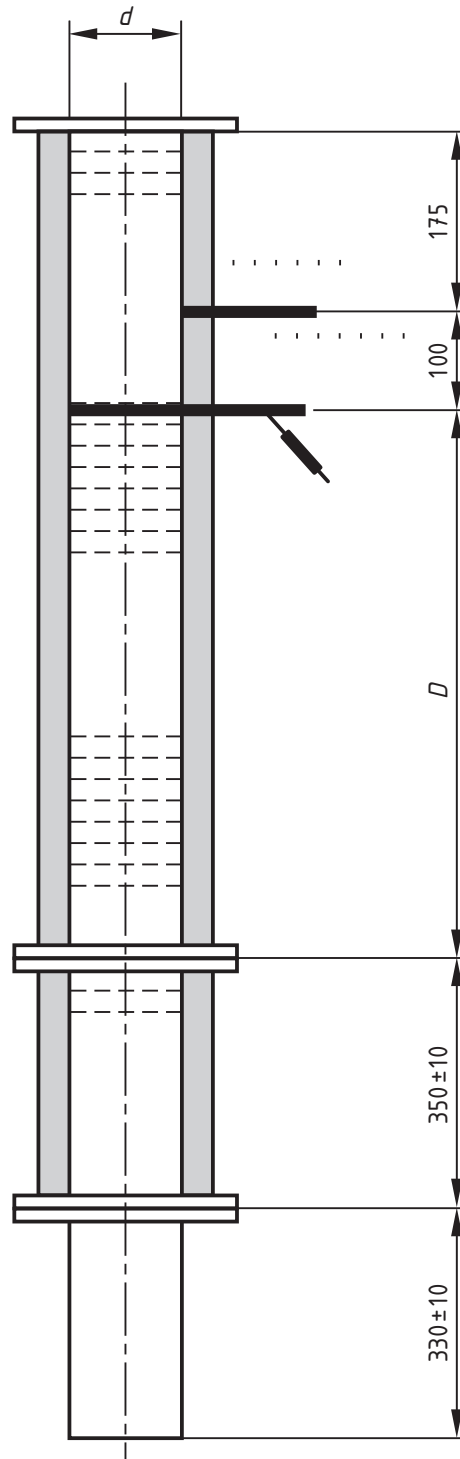

Dimensions of measurement sections

Flue spigot/socket diameter \varnothing	d	D
≤ 180	150	750
$180 < \varnothing \leq 250$	200	1 000
> 250	300	1 500

Figure A.9 — Details and dimensions of measurement section for vertical flue outlet

Dimensions in millimetres
Tolerance on dimensions ± 1 mm
except where shown otherwise

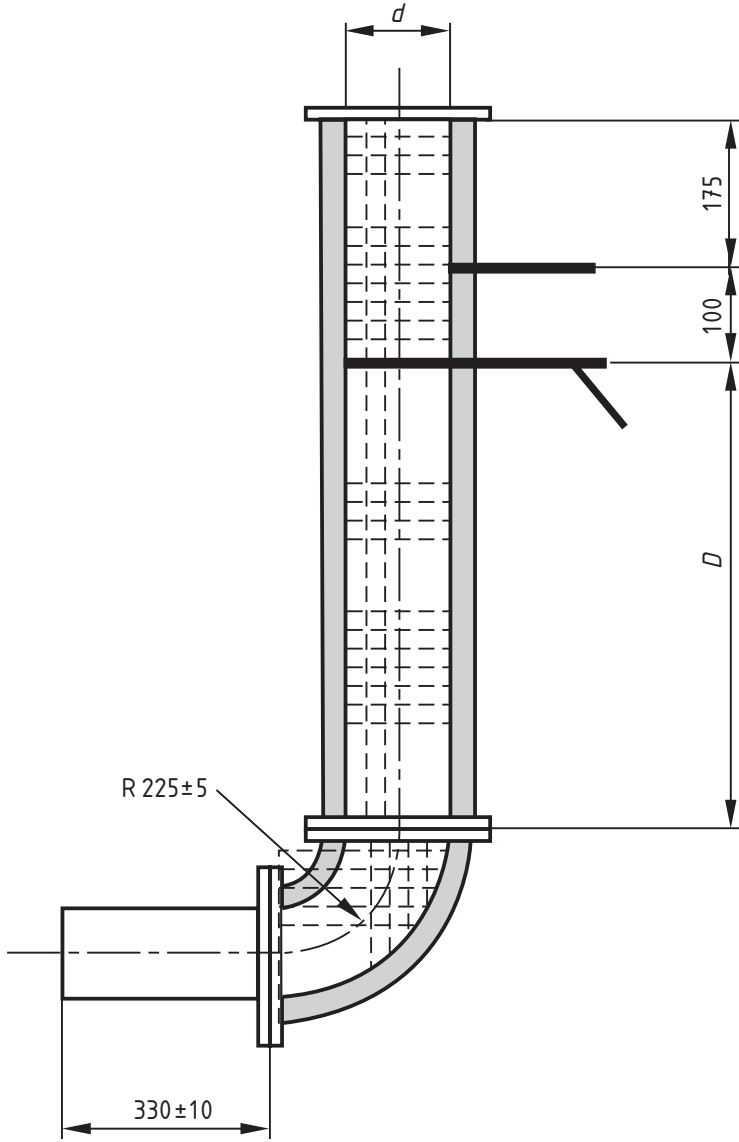

Dimensions of measurement section

Flue spigot/socket diameter \varnothing	d	D
≤ 180	150	750
$180 < \varnothing \leq 250$	200	1 000
> 250	300	1 500

Figure A.10 — Details and dimensions of measurement section for horizontal flue outlet

Dimensions in millimetres

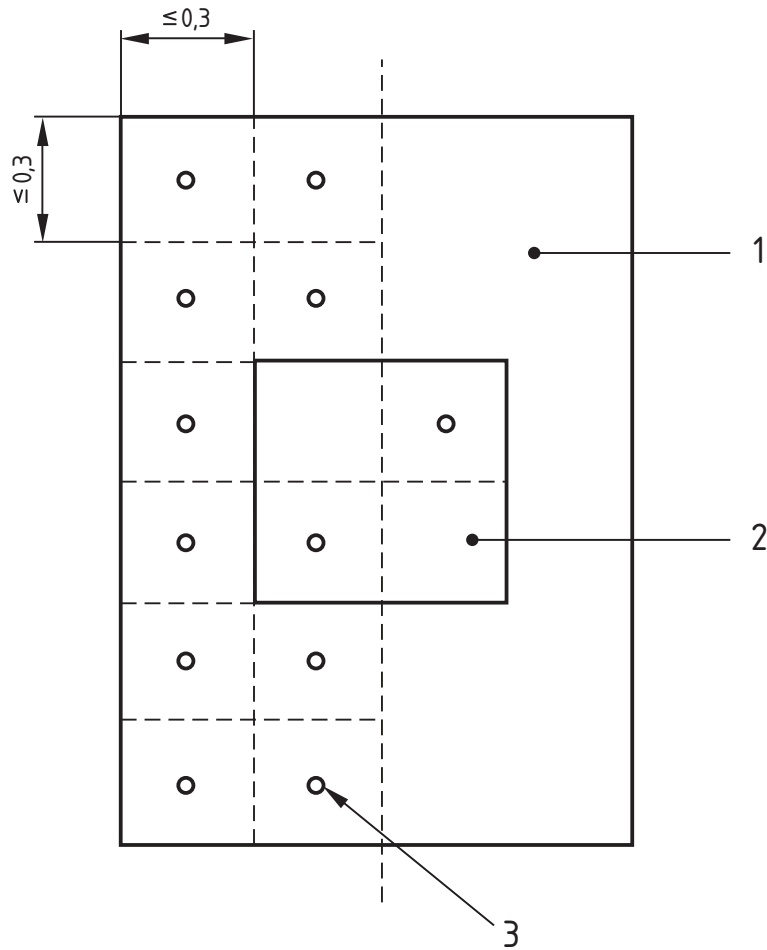

Key

- 1 appliance front
- 2 fire door
- 3 measurement point

Figure A.11 — Example of location of differential surface temperature points on slow heat release appliance

Annex B (normative)

Test fuels and recommended fuels

B.1 General

The standardised test fuels and their various specifications as detailed in Table B.1, representing each of the various types of commercially available fuels, shall be used as the respective test fuel when undertaking the thermal testing of an appliance against the performance requirements of this European Standard.

Selection, preparation and analysis of the test fuel shall be in accordance with the methods described in B.2.

As specified in 7.2 it is the responsibility of the appliance manufacturer to declare in the appliance operating instructions the types of commercially available fuels he recommends for use in the appliance. For reference purposes table B.2 gives a list of the types of currently available commercial fuels against each test fuel type as well as detailing their typical characteristics. The tests for suitability of a recommended fuel are described in B.3.

B.2 Test fuel

B.2.1 Selection of test fuel

Based upon the number of types of commercial fuels recommended by the appliance manufacturer in the operating instructions, the test laboratory shall select from Table B.1 the appropriate test fuel(s) corresponding to each of those recommended commercial fuel types. The size grading of the test fuel shall be in accordance with, that specified by the appliance manufacturer in his operating instructions.

B.2.2 Storage, preparation and analysis

Each batch of test fuel shall be stored under cover and prior to use solid mineral fuels shall be sieved to ensure that the proportions of oversize and undersize material present are each no greater than 5 % by mass.

When sampled and analysed in accordance with the appropriate ISO test method specified in Tables B.1 and B.2, each batch of test fuel shall conform to the appropriate specification given in Table B.1.

Where the measured moisture content exceeds the specification given in Table B.1, the test fuel shall be air dried until the moisture content meets the specification.

It is the responsibility of the test laboratory to ensure that the properties of the test fuel used meet the appropriate test fuel specifications as given in Table B.1.

NOTE The analysis may be guaranteed by a supplier's certificate of analysis.

The analysis and specification for the test fuel(s) used shall be given in the test report of the appliance performance.

B.3 Tests for recommended fuels

B.3.1 Basis of testing

The testing of a recommended fuel shall be carried out using a standard appliance previously type tested and chosen by the test laboratory to be representative of its appliance class and type. The chosen appliance shall be installed in accordance with the installation methods given in A.2 of this standard as appropriate to its class and type and using the test and measuring equipment described in A.2 to A.3 of this European Standard.

The degree of testing to be undertaken depends on whether or not the fuel lies within the commercial fuel specification of Table B.2 and is considered to be properly represented by a test fuel from Table B.1. The process of selecting the tests to be carried out shall be as shown diagrammatically in Figure B.1 and the methods and criteria for the tests shall be as described in B.3.2.

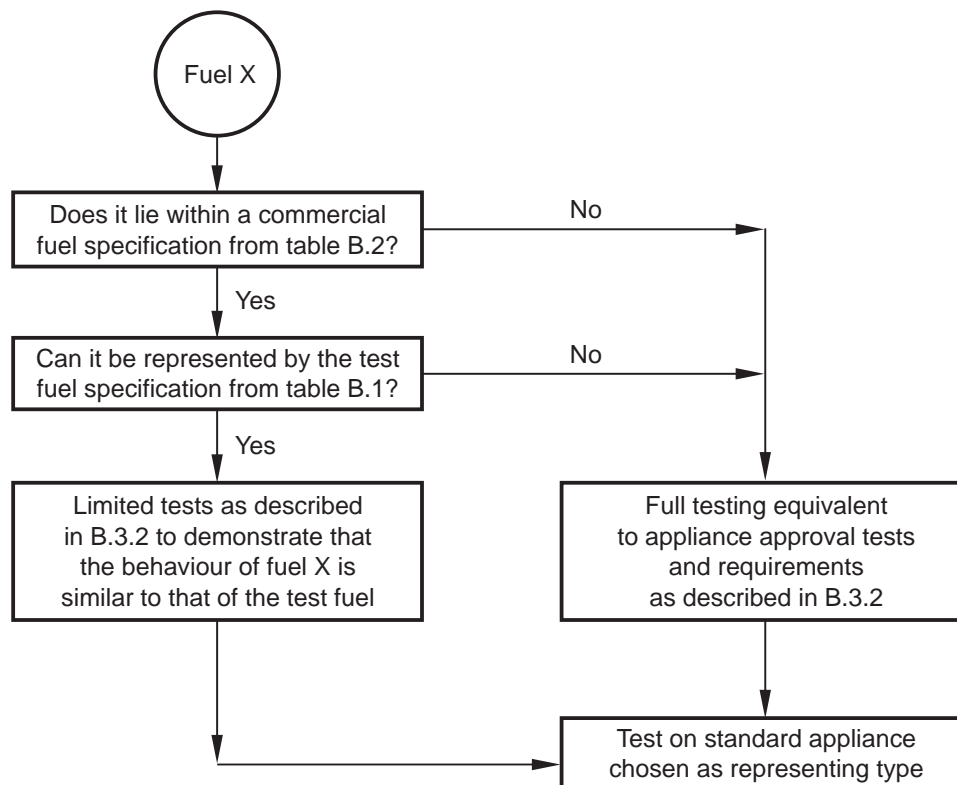

Figure B.1 — Flow chart showing selection process for tests on recommended fuels

B.3.2 Test methods and criteria

Where a recommended commercial fuel is technically represented by a test fuel in Table B.1 and its analysis lies within the analysis range of the commercial fuel types given in Table B.2 then it shall be subjected to limited testing in accordance with the burning rate performance test method given in A.4.6 of this European Standard as appropriate for that appliance class and type. The limited tests to be performed and the criteria to be met shall be as follows:

- 1) burning rate performance test in accordance with A.4.6:
- total heat output to be not less than 95 % of that claimed by the appliance manufacturer and confirmed in the test using the test fuel(s);
- total efficiency to be not less than the minimum efficiency claimed by the appliance manufacturer for the test fuel as detailed in 6.3;

- test duration to be not less than 95 % of the duration given in 6.6;
- CO emission not to exceed the value declared by the appliance manufacturer for the test fuel as detailed in 6.2;
- the temperature requirements concerning clearances from combustible materials detailed in 5.3 shall be satisfied.

Where a new commercially available fuel is not technically represented by a test fuel type listed in Table B.1 or its analyses lies outside the analyses range of the commercial fuel types given in Table B.2 or its nature and characteristics are such that its performance cannot be predicted from the information or analyses provided then the fuel shall be fully tested. The fuel shall be tested on a standard previously type tested appliance (or appliances) chosen to be representative of the class and/or type of appliance on which the fuel will be burned to ensure the safety requirements detailed in 5.1 to 5.4, and the performance requirements detailed in 6.1 to 6.6 are met.

NOTE Where appropriate, the performance testing of a recommended fuel as being suitable for use on a particular appliance type may be undertaken by the appliance manufacturer, the fuel producer or by an independent testing laboratory.

EN 15250:2007 (E)

Table B.1 — Test fuel specifications

Commercial fuel types	Anthracite Dry coal	Hard Coke	Low Temp Coke	Briquetted fuel for closed appliances	Briquetted fuel for open fires	Bituminous coal	Lignite briquettes	Peat briquettes	Wood logs
Test fuel Designation	A	B	C	D	E	F	G	H	Beech, birch or hornbeam
Moisture content (as fired basis) ISO 11722:1999 and ISO 687:2004	< 5 %	< 5 %	< 5 %	< 5 %	< 5 %	(8 ± 2,5) %	(18,5 ± 2) %	(11 ± 2) %	(16 ± 4) %
Ash content (as fired basis) ISO 1171:1997	(5 ± 2) %	(7 ± 2) %	(7 ± 2) %	(8 ± 3) %	(5 ± 2) %	(6 ± 2) %	< 6 %	< 4 %	< 1 %
Volatile matter (dry, ash-free basis) ISO 562:1998	< 14 %	< 2 %	(8 ± 2) %	< 13 %	< 18 %	> 30 %	< 55 %	(68 ± 3) %	(84 ± 4) %
Hydrogen content (as fired basis) ISO 609:1996	(4 ± 1) %	< 0,5 %	< 3 %	< 4 %	< 4 %	(4 ± 1) %	≤ 4 %	(5,2 ± 0,7) %	(5 ± 1) %
Carbon content (as fired basis) ISO 609:1996	(82 ± 5) %	(90 ± 5) %	(78 ± 3) %	(82 ± 5) %	(80 ± 5) %	(72 ± 5) %	(50 - 55) %	(48,5 ± 4,5) %	(40 ± 5) %

(to be continued)

Table B.1 (concluded)

Sulfur content (as fired basis) ISO 351:1996 and ISO 334:1992	< 1 %	< 1,4 %	< 2 %	< 1,8 %	< 1,8 %	< 1,8 %	≤ 2 %	≤ 1 %	< 0,3 %	< 0,1 %	
Net (lower) calorific value (as fired basis) ISO 1928:1995	> 28 kJ/kg	> 26 kJ/kg	> 28 kJ/kg	> 29 kJ/kg	> 29 kJ/kg	> 29 kJ/kg	> 26 500 kJ/kg	≤ 21 000 kJ/kg	> 17 000 kJ/kg	$H_{\text{low}} = \frac{(H_{\text{uwt}}(100-w)-2,44w)}{100}$	/
Size, length	commercial size in accordance with manufacturer's instructions *										
Swelling index ISO 501:2003							according to manufacturer's instructions				
A maximum of 5 % oversize and undersize only is permissible in the test fuel.											
NOTE Some countries have national regulations on the type and quality (e.g. sulfur content) of fuels which have to be complied with in those countries.											

EN 15250:2007 (E)

Table B.2 — Typical commercial fuel specifications

Commercial fuel types	Anthracite Dry steam coal	Hard coke	Low temp coke	Briquetted fuel for closed appliances	Briquetted fuel for open fires	Bituminous coal	Lignite briquettes	Peat briquettes	Wood logs	Compressed, untreated wood
Moisture content (as fired basis) ISO 11722:1999 and ISO 687:2004	3 % to 6 %	1 % to 16 %	1 % to 16 %	< 14 %	< 14 %	3 % to 12 %	15 % to 22 %	9 % to 14 %	12 % to 25 %	< 12 %
Ash content (as fired basis) ISO 1171:1997	3 % to 14 %	4 % to 15 %	4 % to 10 %	4 % to 12 %	3 % to 8 %	2 % to 8 %	1 % to 12 %	< 6 %	< 1,5 %	< 1,5 %
Volatile matter (dry, ash-free basis) ISO 562:1998	3 % to 14 %	< 2,0 %	6 % to 12 %	5 % to 17 %	10 % to 18 %	20 % to 45 %	51 % to 62 %	63 % to 73 %	80 % to 88 %	80 % to 88 %
Hydrogen content (as fired basis) ISO 609:1996	2 % to 5 %	< 0,5 %	< 3 %	2 % to 4 %	2 % to 4 %	4 % to 5 %	3 % to 4 %	4,5 % to 5,8 %	4 % to 7 %	5,0 % to 6,5 %

(to be continued)

Table B.2 (concluded)

Carbon content (as fired basis) ISO 609:1996	80 % to 90 %	75 % to 95 %	75 % to 85 %	70 % to 90 %	65 % to 85 %	50 % to 80 %	50 % to 55 %	44 % to 53 %	35 % to 45 %	40 % to 50 %
Sulfur content (as fired basis) ISO 351:1996 and ISO 334:1992	< 1,8 %	< 1,8 %	< 1,8 %	< 1,8 %	< 1,8 %	0,8 % to 2,1 %	0,2 % to 3,5 %	< 0,3	< 0,1 %	< 0,1 %
Net (lower) calorific value (as fired basis) ISO 1928:1995	29 310 kJ/kg to 33 000 kJ/kg	25 100 kJ/kg to 29 000 kJ/kg	26 000 kJ/kg to 30 000 kJ/kg	27 000 kJ/kg to 32 300 kJ/kg	26 000 kJ/kg to 32 000 kJ/kg	22 500 kJ/kg to 31 000 kJ/kg	18 000 kJ/kg to 21 000 kJ/kg	16 800 kJ/kg to 19 300 kJ/kg	17 000 kJ/kg to 20 000 kJ/kg	17 500 kJ/kg to 19 500 kJ/kg
Size, length	3 mm to 80 mm	9,5 mm to 90 mm	10 mm to 80 mm	20 g to 140 g	20 g to 140 g	75 mm to 130 mm	50 mm to 100 mm or 155 mm to 182 mm	briquettes, nuggets		
Swelling index						0 to 9				
ISO 501:2003										
Length									0,2 m to 1,0 m	
Designation of standard test fuel to be used	A	B	C	D	E	F	G	H	Beech, birch or hornbeam	Beech, birch or hornbeam wood logs
NOTE Some countries have national regulations on the type and quality (e.g. sulfur content) of fuels, which have to be complied with in those countries.										

Annex C (informative)

Calculation of an approximate heat release curve against time

The heat output Q (W) from the surface area A is calculated as an approximation by assuming the rate of heat release to be due to radiation and convection according to Equation (C.1).

$$Q/(kA) = q = \sigma F [(T_s + 273.15)^4 - (T_r + 273.15)^4] + C(T_s - T_r)^n \quad (\text{C.1})$$

where

q is heat release rate at time t (W/m²);

k is scaling factor;

A is total surface area of a SHRA (m²);

$\sigma = 5,67 \times 10^{-8}$ W m⁻²K⁻⁴ (Stefan-Boltzmann's constant);

F is view factor;

T_s is the mean surface temperature (°C) at time t ;

T_r is ambient temperature (°C);

C and n are constants for convection.

In practise for turbulent flow a value of $n = 1,36$ may be assumed. The view factor F depends on the emissivity of the stove surface material and also on the room walls and as an approximation a value of 0,8 can be used. Similarly a value for C of 1,2 W m⁻²K ^{n} may be used.

Equation (C.1) has its limitations, but if it is scaled with a factor kA so that the energy released to the room is the same as energy from the combustion, the scaling factor including the heat releasing surface area A becomes

$$kA = E / I \quad (\text{C.2})$$

in which E is the energy gained from the burning of the wood batch, $E = \eta m H_u$, η is the efficiency of the appliance, m is mass of wood batch, H_u is the lower heating value of the wood and

$$I = \int_0^{\infty} q dt = t_h q_{ave} + R \quad (\text{C.3})$$

where q_{ave} is the time average of q during the measuring period t_h . The approximation, Equation (C.1), gives the estimation of the rate of heat release Q as function of time t after kA has been evaluated from the measurements using Equation (C.2).

R is the correction term that accounts for the energy remained in the stove after the measurements, if the measurements are stopped before T_s reaches T_r . The residual tail energy in the stove can be estimated assuming Newton's law of cooling. It assumes that the temperature difference will decay exponentially with time. The area of the tail which equals to the residual energy, can be calculated, when the heat flows q_h and q_1 at two times t_h and t_1 are solved from Equation (C.1),

$$R = \frac{(t_h - t_1)q_h}{\ln(q_1 / q_h)} \quad (\text{C4})$$

Figure C.1 illustrates the procedure.

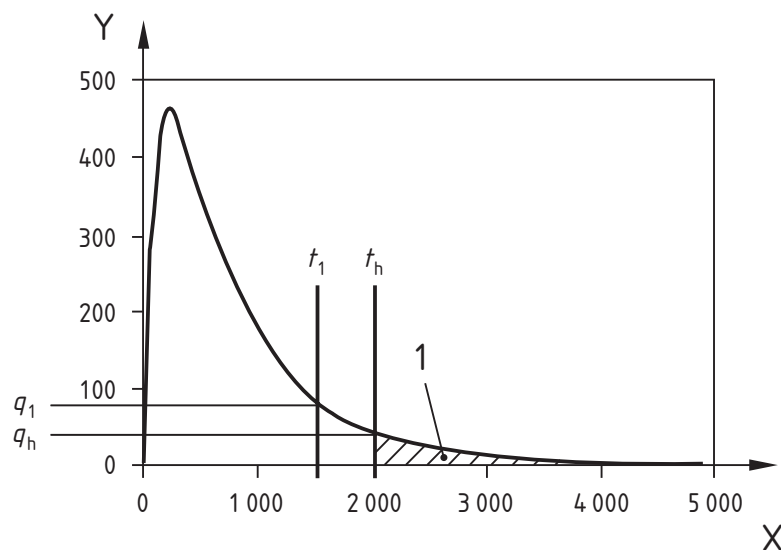

Key

X	time (min)
Y	q (W/m^2)

Figure C.1 — Residual energy in the stove

NOTE In Figure C.1 the mean differential surface temperature measurements have been stopped at time t_h .

Calculation example:

For the typical conditions given above (height of stove 1,5 m, $\frac{1}{2}(T_s + T_r) = 30$ °C) for turbulent flow $n \approx 1,36$ and $C \approx 1,2 \text{ W m}^{-2} \text{ K}^{-n}$ and $F \approx 0,8$, the heat release rate curve is shown in Figure C.2.

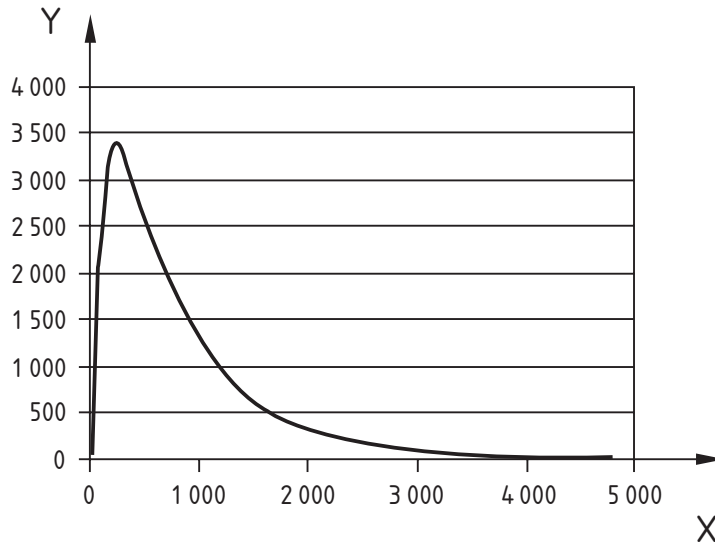

Key

- X time (min)
- Y calculated heat release rate (W)

Figure C.2 — Calculated heat release rate

In the case shown in Figure C.2, the surface temperature measurements were carried out until the mean differential surface temperature was practically 0 K.

In the case where measurements have been stopped before the mean differential surface temperature is 0 K, first the residual energy has to be calculated using Equation (C.4). For example at time $t_h = 200.3$ min (see Figure C.1), the heat release rate $q_h = 309.3$ W, and at time $t_f = 151.0$ min, 590.8 W, Equation (C.4) gives $R = (200.3 - 151.0) \times 60 \times 309.3 / \ln(590.8/309.3) = 14.14$ MJ.

Then Equations (C.3) and (C.2) are used to solve the scaling factor k . Then it is possible to calculate the heat release rate curve using Equation (C.1).

This calculation procedure assumes that

- the shape of the heat release rate curve is according to Equation (C.1);
- total energy output equals to total energy input times efficiency.

Parameters in Equation (C.1) can be changed. Changes result in a slightly different shape of the heat release rate curve. However, total energy output remains unchanged.

Annex ZA (informative)

Clauses of this European standard addressing the provisions of the EU Construction Products Directive

ZA.1 Scope and relevant characteristics

This European Standard has been prepared under Mandate M/129 “Space heating appliances” given to CEN by the European Commission and the European Free Trade Association.

The clauses of this European standard shown in this Annex meet the requirements of the Mandate given under the EU Construction Products Directive (89/106/EEC).

Compliance with these clauses confers a presumption of fitness of slow heat release appliances fired by solid fuels covered by this annex for their intended uses indicated herein; reference shall be made to the information accompanying the CE marking.

WARNING: Other requirements and other EU Directives, not affecting the fitness for intended use, can be applicable to slow heat release appliances fired by solid fuels falling within the scope of this European Standard.

NOTE 1 In addition to any specific clauses relating to dangerous substances contained in this Standard, there may be other requirements applicable to the products falling within its scope (e.g. transposed European legislation and national laws, regulations and administrative provisions). In order to meet the provisions of the EU Construction Products Directive, these requirements need also to be complied with, when and where they apply.

NOTE 2 An informative database of European and national provisions on dangerous substances is available at the Construction web site on EUROPA (accessed through <http://europa.eu.int/comm/enterprise/construction/internal/dangsub/dangmain.htm>).

This annex establishes the conditions for the CE marking of slow heat release appliances fired by solid fuels intended for the uses indicated in Table ZA.1 and shows the relevant clauses applicable:

This annex has the same scope as Clause 1 of this standard and is defined by Table ZA.1.

Table ZA.1 — Relevant clauses

Product: Slow heat release appliances fired by solid fuels as covered under the scope of this standard.			
Intended use: Space heating in residential buildings			
Essential Characteristics	Requirement clauses in this EN	Levels and/or classes	Notes
Fire safety	4.2.1, 4.2.2, 4.2.3, 4.2.4, 4.2.5, 4.2.6, 4.2.7, 4.2.9, 4.2.11, 5.1, 5.3	-	Pass/fail criterion
Emission of combustion products	4.2.1, 4.2.3, 4.2.7, 4.2.8, 4.2.9, 4.2.10, 5.1, 6.1, 6.2, 6.4	-	Test result for CO emission with threshold value < 0,3 %
Release of dangerous substance	ZA.1	-	
Surface temperature	4.2.1, 5.1, 5.2, 5.3	-	Pass/fail criterion based on manufacturer's declared distance to adjacent combustible materials
Flue gas temperature	6.1	-	Test result to be declared
Electrical safety	5.4	-	
Mechanical resistance (to carry a chimney/flue)	4.2.1, 4.2.3	-	Pass/fail criterion
Thermal output/Energy efficiency	6.3, 6.4 to 6.6	-	Test result for efficiency with threshold value ≥ 70 %
Thermal storage capacity	6.6		Declared amount of energy stored

The requirement on a certain characteristic is not applicable in those Member States (MSs) where there are no regulatory requirements on that characteristic for the intended end use of the product. In this case, manufacturers placing their products on the market of these MSs are not obliged to determine nor declare the performance of their products with regard to this characteristic and the option "No performance determined" (NPD) in the information accompanying the CE marking (see ZA.3) may be used. The NPD option may not be used, however, where the characteristic is subject to a threshold level.

ZA.2 Procedure for the attestation of conformity of slow heat release appliances fired by solid fuels

ZA.2.1 System of attestation of conformity

The system of attestation of conformity of slow heat release appliances fired by solid fuels indicated in Table ZA.1, in accordance with the decision of the Commission 1999/471/EC of 1999-06-29 amended by the Commission Decision 01/596/EC and as given in Annex III of the mandate for "Space Heating Appliances", is shown in Table ZA.2 for the intended use and relevant level(s) and classes.

Table ZA.2 — Attestation of conformity systems

Product	Intended use	Level(s) or class(es)	Attestation of conformity system
Slow heat release appliances fired by solid fuel	Space heating in residential buildings	-	3
System 3: See Directive 89/106/EEC (CPD) Annex III.2.(ii), Second possibility			

The attestation of conformity of slow heat release appliances fired by solid fuels in Table ZA.1 shall be based on the evaluation of conformity procedures indicated in Table ZA.3 resulting from the application of the clauses of this European Standard indicated therein.

Table ZA.3. — Assignment of evaluation of conformity tasks (for system 3)

Tasks		Content of the task	Evaluation of conformity clauses to apply
Tasks for the manufacturer	Factory production control (F.P.C)	Parameters related to all relevant characteristics of Table ZA.1	9.3
	Initial type testing	All other characteristics of Table ZA.1 not tested by the notified body i.e. those shown below	9.2
Tasks for the notified body	Initial type testing	Fire safety Emission of combustion products Surface temperature Thermal output Energy efficiency Release of dangerous substance Thermal storage capacity	9.2

ZA.2.2 EC Declaration of conformity

When compliance with the conditions of this Annex is achieved, the manufacturer or his agent established in the EEA, shall draw up and retain a declaration of conformity (EC Declaration of conformity), which entitles the manufacturer to affix the CE marking. This declaration shall include:

- name and address of the manufacturer, or his authorised representative established in the EEA, and place of production;

NOTE 1 The manufacturer may also be the person responsible for placing the product onto the EEA market, if he takes responsibility for CE marking.

- description of the product (type, identification, use, ...), and a copy of the information accompanying the CE marking;

NOTE 2 Where some of the information required for the Declaration is already given in the CE marking information, it does not need to be repeated.

- provisions to which the product conforms (i.e. Annex ZA of this EN), and a reference to the ITT report(s) and factory production control records.
- particular conditions applicable to the use of the product (e.g. provisions for use under certain conditions);
- name and address of the notified laboratory(ies),
- name of, and position held by, the person empowered to sign the declaration on behalf of the manufacturer or his authorised representative.

The above mentioned declaration shall be presented in the language or languages of the Member State in which the product is to be used.

ZA.3 CE Marking and labelling

The manufacturer or his authorised representative established within the EEA is responsible for the affixing of the CE marking. The CE marking symbol to affix shall be in accordance with Directive 93/68/EC and shall be shown on the slow heat release appliance (or when not possible it may be on the accompanying label, the packaging or on the accompanying commercial documents e.g. a delivery note). The following information shall accompany the CE marking symbol:

- name or identifying mark and registered address of the producer, see Note 1 in ZA.2.2;
- the last two digits of the year in which the marking is affixed;
- reference to this European Standard, i.e. EN 15250:2007;
- description of the product: generic name, material, dimensions, ... and intended use;
- information on those relevant essential characteristics listed in Table ZA.1 which are to be declared presented as:
 - declared values and, where relevant, level or class (including "pass" for pass/fail requirements, where necessary) to declare for each essential characteristic as indicated in "Notes" in Table ZA.1;
 - "No performance determined" for characteristics where this is relevant;

- as an alternative, a standard designation which shows some or all of the relevant characteristics (where the designation covers only some characteristics, it will need to be supplemented with declared values for other characteristics as above).

In particular the following information shall be given against the recommended fuel (or types):

- the recommended fuel type (or types);
- distance to adjacent combustible materials;
- emission of CO in combustion products (test result value but $< 0,3 \%$);
- maximum operating pressure (where relevant);
- flue gas temperature;
- thermal storage capacity;
- energy efficiency (test result value but $\geq 70 \%$).

The “No performance determined” (NPD) option may not be used where the characteristic is subject to a threshold level. Otherwise, the NPD option may be used when and where the characteristic, for a given intended use, is not subject to regulatory requirements in the Member State of destination.

Figure ZA.1 gives an example of the information to be given on the product, label, packaging and/or commercial documents.

CE			
AnyCo Ltd, PO Box 21, B-1050			
07			
EN 15250			
Slow heat release appliance fired by solid fuel			
Distance to adjacent combustible materials: 140 cm minimum			
Emission of CO in combustion products : 0,3 %			
Flue gas temperature		: 300 °C	
Thermal output		: 30 kJ	
Thermal storage capacity	100 %	50 %	25 %
	Peak	of Peak	of Peak
	After 3,1 h	9 h	20 h
Energy efficiency		: 73 %	
Fuel types		: wood logs	

CE conformity marking, consisting of the "CE"-symbol given in Directive 93/68/EEC.

Name or identifying mark and registered address of the producer

Last two digits of the year in which the marking was affixed

No. of European Standard

Description of product

and

information on regulated characteristics

Figure ZA.1 — Example CE marking information

In addition to any specific information relating to dangerous substances shown above, the product should also be accompanied, when and where required and in the appropriate form, by documentation listing any other legislation on dangerous substances for which compliance is claimed, together with any information required by that legislation.

NOTE 1 European legislation without national derogations need not be mentioned.

NOTE 2 Affixing the CE marking symbol means, if a product is subject to more than one directive, that it complies with all applicable directives.

Bibliography

- [1] EN ISO 9001, *Quality management systems — Requirements (ISO 9001:2000)*

BSI — British Standards Institution

BSI is the independent national body responsible for preparing British Standards. It presents the UK view on standards in Europe and at the international level. It is incorporated by Royal Charter.

Revisions

British Standards are updated by amendment or revision. Users of British Standards should make sure that they possess the latest amendments or editions.

It is the constant aim of BSI to improve the quality of our products and services. We would be grateful if anyone finding an inaccuracy or ambiguity while using this British Standard would inform the Secretary of the technical committee responsible, the identity of which can be found on the inside front cover.
Tel: +44 (0)20 8996 9000. Fax: +44 (0)20 8996 7400.

BSI offers members an individual updating service called PLUS which ensures that subscribers automatically receive the latest editions of standards.

Buying standards

Orders for all BSI, international and foreign standards publications should be addressed to Customer Services. Tel: +44 (0)20 8996 9001.
Fax: +44 (0)20 8996 7001. Email: orders@bsi-global.com. Standards are also available from the BSI website at <http://www.bsi-global.com>.

In response to orders for international standards, it is BSI policy to supply the BSI implementation of those that have been published as British Standards, unless otherwise requested.

Information on standards

BSI provides a wide range of information on national, European and international standards through its Library and its Technical Help to Exporters Service. Various BSI electronic information services are also available which give details on all its products and services. Contact the Information Centre.
Tel: +44 (0)20 8996 7111. Fax: +44 (0)20 8996 7048. Email: info@bsi-global.com.

Subscribing members of BSI are kept up to date with standards developments and receive substantial discounts on the purchase price of standards. For details of these and other benefits contact Membership Administration.
Tel: +44 (0)20 8996 7002. Fax: +44 (0)20 8996 7001.
Email: membership@bsi-global.com.

Information regarding online access to British Standards via British Standards Online can be found at <http://www.bsi-global.com/bsonline>.

Further information about BSI is available on the BSI website at <http://www.bsi-global.com>.

Copyright

Copyright subsists in all BSI publications. BSI also holds the copyright, in the UK, of the publications of the international standardization bodies. Except as permitted under the Copyright, Designs and Patents Act 1988 no extract may be reproduced, stored in a retrieval system or transmitted in any form or by any means – electronic, photocopying, recording or otherwise – without prior written permission from BSI.

This does not preclude the free use, in the course of implementing the standard, of necessary details such as symbols, and size, type or grade designations. If these details are to be used for any other purpose than implementation then the prior written permission of BSI must be obtained.

Details and advice can be obtained from the Copyright & Licensing Manager.
Tel: +44 (0)20 8996 7070. Fax: +44 (0)20 8996 7553.
Email: copyright@bsi-global.com.